

6. *Executive Order 13175: Consultation and Coordination with Indian Tribal Governments*—Executive Order 13175 (65 FR 67240, November 6, 2000) does not apply to this rule because it will not have tribal implications (i.e., substantial direct effects on one or more Indian tribes, on the relationship between the Federal government and Indian tribes, or on the distribution of power and responsibilities between the Federal Government and Indian tribes).

7. *Executive Order 13045: Protection of Children from Environmental Health & Safety Risks*—This rule is not subject to Executive Order 13045 (62 FR 19885, April 23, 1997) because it is not economically significant and it is not based on health or safety risks.

8. *Executive Order 13211: Actions that Significantly Affect Energy Supply, Distribution, or Use*—This rule is not subject to Executive Order 13211 (66 FR 28355, May 22, 2001) because it is not a significant regulatory action as defined in Executive Order 12866.

9. *National Technology Transfer Advancement Act*—EPA approves State programs as long as they meet criteria required by RCRA, so it would be inconsistent with applicable law for EPA, in its review of a State program, to require the use of any particular voluntary consensus standard in place of another standard that meets the requirements of RCRA. Thus, section 12(d) of the National Technology Transfer and Advancement Act (15 U.S.C. 272 Note) does not apply to this rule.

10. *Congressional Review Act*—EPA will submit a report containing this rule and other information required by the Congressional Review Act (5 U.S.C. 801 et seq.) to the U.S. Senate, the U.S. House of Representatives, and the Comptroller General of the United States prior to publication in the **Federal Register**. A major rule cannot take effect until 60 days after it is published in the **Federal Register**. This action is not a “major rule” as defined by 5 U.S.C. 804(2). This action will be effective on May 10, 2013.

List of Subjects in 40 CFR Part 271

Environmental protection, Administrative practice and procedure, Confidential business information, Hazardous waste, Hazardous waste transportation, Indian lands, Intergovernmental relations, Penalties, Reporting and recordkeeping requirements.

Authority: This action is issued under the authority of sections 2002(a), 3006 and 7004(b) of the Solid Waste Disposal Act as amended (42 U.S.C. 6912(a), 6926, 6974(b)).

Dated: December 19, 2012.

Judith A. Enck,

Regional Administrator, Region 2.

[FR Doc. 2013–05481 Filed 3–8–13; 8:45 am]

BILLING CODE 6560–50–P

DEPARTMENT OF TRANSPORTATION

Pipeline and Hazardous Materials Safety Administration

49 CFR Parts 105, 171, 172, 173, 177, 178, and 180

[Docket No. PHMSA–2011–0138 (HM–218G)]

RIN 2137–AE78

Hazardous Materials; Miscellaneous Amendments (RRR)

AGENCY: Pipeline and Hazardous Materials Safety Administration (PHMSA), DOT.

ACTION: Final rule.

SUMMARY: PHMSA is amending the Hazardous Materials Regulations (HMR) to make miscellaneous amendments to update and clarify certain regulatory requirements. These amendments promote safer transportation practices, eliminate unnecessary regulatory requirements, address a petition for rulemaking, incorporate a special permit into the HMR, facilitate international commerce, and simplify the regulations. These amendments also update various entries in the Hazardous Materials Table (HMT) and corresponding special provisions, clarify the lab pack requirements for temperature-controlled materials, and require hazmat employers to make hazmat employee training records available upon request to an authorized official of the Department of Transportation (DOT) or an entity explicitly granted authority to enforce the HMR.

DATES: *Effective Date:* This rule is effective May 10, 2013.

Voluntary Compliance Date: Voluntary compliance with all amendments is authorized March 11, 2013.

FOR FURTHER INFORMATION CONTACT: Rob Benedict, Standards and Rulemaking Division, (202) 366–8553, Pipeline and Hazardous Materials Safety Administration, U.S. Department of Transportation, 1200 New Jersey Avenue SE., Washington, DC 20590–0001.

SUPPLEMENTARY INFORMATION:

Contents

I. Background

A. Notice of Proposed Rulemaking (NPRM)

- B. Commenters
- II. Discussion of Amendments and Applicable Comments
 - A. General Comments
 - B. Provisions Adopted in This Final Rule and Discussion of Comments
 - C. Comments Beyond the Scope of This Rulemaking
 - D. Provisions Not Adopted in This Final Rule and Discussion of Comments
- III. Regulatory Analyses and Notices
 - A. Statutory/Legal Authority for the Rulemaking
 - B. Executive Order 12866, Executive Order 13563 and DOT Regulatory Policies and Procedures
 - C. Executive Order 13132
 - D. Executive Order 13175
 - E. Regulatory Flexibility Act, Executive Order 13272, and DOT Procedures and Policies
 - F. Paperwork Reduction Act
 - G. Regulatory Identifier Number (RIN)
 - H. Unfunded Mandates Reform Act
 - I. Environmental Assessment
 - J. Privacy Act
 - K. International Trade Analysis

I. Background

A. Notice of Proposed Rulemaking (NPRM)

On April 26, 2012, PHMSA published a NPRM under Docket PHMSA 2011–0138 [77 FR 24885] (HM–218G) that proposed amendments to update and clarify existing requirements of the HMR. The NPRM and this Final Rule are part of the Department of Transportation’s Retrospective Regulatory Review (RRR) designed to identify ways to improve the Hazardous Materials Regulations (HMR; 49 CFR parts 171–180). The NPRM proposed amendments to update and clarify existing requirements by incorporating changes into the HMR based on PHMSA’s own initiatives. The proposed amendments were identified through an extensive review of the HMR and previously issued letters of interpretation to the regulated hazardous materials transportation community. In addition, the NPRM proposed to incorporate a special permit with a longstanding history of safety into the HMR and respond to a petition for rulemaking. The changes proposed in the April 26, 2012 NPRM are summarized below:

- Permit designated agents for non-residents to submit designation requests by electronic mail in addition to traditional mail.

- Add the Sulphur Institute’s (TSI) “Molten Sulphur Rail Tank Car Guidance” document to the list of informational materials not requiring incorporation by reference in § 171.7 (Responds to petition for rulemaking P–1581).

- Revise the § 172.101 Hazardous Materials Table (HMT) to correct an error in the transportation requirements for entries listed under the proper shipping name, “Hydrazine Dicarboxylic Acid Diazide.”
- Revise the § 172.101 HMT to remove the entry for “Zinc ethyl, see Diethylzinc” that was superseded by proper shipping names adopted in a previous rulemaking.
- Add the inadvertently omitted entries for “Paint related material, flammable, corrosive (*including paint thinning or reducing compound*)” UN3469, PG II, and PG III to the § 172.101 HMT.
- Remove references to special provisions B72 and B74 in § 172.102.
- Revise special provision 138 in § 172.102 to clarify the lead solubility calculation used to classify a material as a Marine Pollutant.
- Revise the shipping paper requirements in § 172.203(e) to permit the placement of phrase “Residue last contained” before or after the basic shipping description sequence, or for rail shipments, directly preceding the proper shipping name in the basic shipping description sequence.
- Update the training recordkeeping requirements in § 172.704 to specify that a hazmat employer must make hazmat employee training records available upon request, at a reasonable time and location, to an authorized official of the Department of Transportation or the Department of Homeland Security (DHS).
- Clarify that the material of trade exception in § 173.6 may be used when

- transporting Division 2.1 and 2.2 gases in Dewar flasks.
- Clarify the lab pack provisions in § 173.12 pertaining to temperature-controlled materials contained in a lab pack.
 - Clarify the exceptions for external emergency self-closing valves on cargo tank motor vehicles (CTMVs) in § 173.33(g) to specify that external emergency self-closing valves on MC 338 cargo tanks containing cryogenic liquids may remain open during transportation.
 - Correct an inadvertent deletion of the § 173.62 packaging requirements for explosives.
 - Incorporate special permit DOT SP-13556 into § 173.134, to authorize the transportation by motor vehicle of certain regulated medical wastes, designated as sharps, in non-DOT specification containers fitted into wheeled racks.
 - Revise the requirements for cargo air transport of alcoholic beverages in § 173.150 to harmonize with the International Civil Aviation Organization’s (ICAO) Technical Instructions (TI).
 - Clarify the exceptions in § 173.159a for non-spillable batteries secured to skids or pallets.
 - Revise § 178.2(c) to clarify the applicability of the closure notification requirements for packages containing residues.
 - Correct regulatory citations in § 178.2(c).
 - Clarify the requirements for the Flame Penetration Resistance test specified for chemical oxygen

- generators and certain compressed gases in Appendix E to Part 178.
- Clarify the inspection record requirements in § 180.416 for discharge systems of cargo tanks transporting liquefied compressed gases.

B. Commenters

The comment period for the April 26, 2012 NPRM closed on June 25, 2012. PHMSA received 22 public comments in response to the NPRM’s proposed amendments, from trade associations representing various industries, individual businesses, and concerned citizens who make up the regulated community. While the majority of the commenters supported the proposals in the NPRM, some commenters expressed adverse opinions with specific proposals. In response to the feedback provided by these commenters, PHMSA will address and discuss both the proposals adopted and not adopted into the HMR by this rulemaking under the heading, “*Discussion of Amendments and Applicable Comments.*” In addition, some commenters provided suggestions for revisions that were not specifically addressed in the NPRM, and therefore, are considered beyond the scope of this rulemaking. The comments, as submitted to this docket, may be accessed via <http://www.regulations.gov> and were submitted by the following individuals, companies, and associations (abbreviations used throughout the document and Docket Reference numbers are also provided):

Commenter	Abbreviation	Docket reference
American Coating Association, Inc	ACA	PHMSA-2011-0138-0012
American Trucking Association	ATA	PHMSA-2011-0138-0007
Association of American Railroads	AAR	PHMSA-2011-0138-0022
Association of Hazmat Shippers	AHS	PHMSA-2011-0138-0011
Council on Safe Transportation of Hazardous Articles, Inc	COSTHA	PHMSA-2011-0138-0010
Dangerous Goods Advisory Council	DGAC	PHMSA-2011-0138-0009
The Fertilizer Institute	TFI	PHMSA-2011-0138-0021
International Vessel Operators Dangerous Goods Association Inc	IVODGA	PHMSA-2011-0138-0014
Koch Sulfur Products Company LLC	KSPC	PHMSA-2011-0138-0025
National Association of Chemical Distributors	NACD	PHMSA-2011-0138-0023
National Tank Truck Carriers	NTTC	PHMSA-2011-0138-0019
Oxbow Sulphur Inc	Oxbow	PHMSA-2011-0138-0018
Potash Corporation of Saskatchewan	PCS	PHMSA-2011-0138-0026
Richard Zbilski	Richard Zbilski	PHMSA-2011-0138-0027
Reusable Industrials Packaging Association	RIPA	PHMSA-2011-0138-0016
Stericycle, Inc	Stericycle	PHMSA-2011-0138-0005
The Sulphur Institute	TSI	PHMSA-2011-0138-0017
Transammonia Inc	Transammonia	PHMSA-2011-0138-0020
Union Tank Car Company	UTCC	PHMSA-2011-0138-0029
U.S. Clay Producers Traffic Association	USCPTA	PHMSA-2011-0138-0024
Utility Solid Waste Activities Group	USWAG	PHMSA-2011-0138-0013
Veolia ES Technical Solutions, L.L.C	Veolia	PHMSA-2011-0138-0008

II. Discussion of Amendments and Applicable Comments

A. General Comments

On September 30, 1993, President Bill Clinton issued Executive Order 12866 which asked Federal agencies “to enhance planning and coordination with respect to both new and existing regulations; to reaffirm the primacy of Federal agencies in the regulatory decision-making process; to restore the integrity and legitimacy of regulatory review and oversight; and to make the process more accessible and open to the public.”

On October 21, 2011, President Barack Obama issued Executive Order 13563 which is supplemental to and reaffirms the principles, structures, and definitions governing contemporary regulatory review that were established in Executive Order 12866. This executive order urged government agencies to consider regulatory approaches that reduce burdens and maintain flexibility and freedom of choice for the public. Finally, federal agencies were directed to periodically review existing significant regulations; retrospectively analyze rules that may be outmoded, ineffective, insufficient, or excessively burdensome; and modify, streamline, expand, or repeal regulatory requirements in accordance with what has been learned.

On May 10, 2012, President Barack Obama issued Executive Order 13610 (Identifying and Reducing Regulatory Burdens) reaffirming the goals of Executive Order 13563 (Improving Regulation and Regulatory Review) issued January 18, 2011, and Executive Order 12866 (Regulatory Planning and Review) issued September 30, 1993. Executive Order 13610 directs agencies to prioritize “those initiatives that will produce significant quantifiable monetary savings or significant quantifiable reductions in paperwork burdens while protecting public health, welfare, safety, and our environment.” Executive Order 13610 further instructs agencies to give consideration to the cumulative effects of their regulations, including cumulative burdens, and prioritize reforms that will significantly reduce burdens.

In accordance with Executive Orders 13610 and 13563, PHMSA has undertaken a retrospective review of the HMR. This final rule and the NPRM that preceded it are part of that initiative, and were based on an internal review of the HMR, special permits, petitions, and letters of interpretation. The April 26, 2012 NPRM specifically addressed a petition, a special permit, and various clarifications identified in letters of

interpretation and through PHMSA internal review of the HMR. The publication of the NPRM provided an opportunity for further public participation in the development of the regulatory amendments, and promoted an exchange of information and perspectives among the various stakeholders.

PHMSA received 22 comments in response to the April 26, 2012 NPRM which were predominately positive. Some commenters agreed in principle with the proposed amendments and offered revisions to improve the clarity of the regulatory text. In some cases, no comments to proposed amendments were received. In these circumstances, PHMSA attributed the lack of comment to either the nature of the amendment being editorial, or a general acknowledgement from the regulated community that no opposition to the change was warranted. Finally, negative comments were also received on some specific issues. A detailed description of the original proposals in the April 26, 2012 NPRM, a summary of the comments received, responses to those comments, and PHMSA’s decision on future actions are detailed below.

B. Provisions Adopted in This Final Rule and Discussion of Comments

In this section, PHMSA discusses the changes proposed in the NPRM and the comments received in response to the NPRM. To clearly identify the issues addressed in this final rule, PHMSA provides the following list of adopted amendments discussed in this section:

- Permit designated agents for non-residents to submit designation requests by electronic mail in addition to traditional mail.
- Add the Sulphur Institute’s (TSI) “Molten Sulphur Rail Tank Car Guidance” document to the list of informational materials not requiring incorporation by reference in § 171.7 (Responds to petition for rulemaking P–1581).
- Revise the § 172.101 HMT to correct an error in the transportation requirements for entries listed under the proper shipping name, “Hydrazine Dicarboxylic Acid Diazide.”
- Revise the § 172.101 HMT to remove the entry for “Zinc ethyl, see Diethylzinc” that was superseded by proper shipping names adopted in a previous rulemaking.
- Add the entries for “Paint related material, flammable, corrosive (including paint thinning or reducing compound)” UN3469, PG II, and PG III to the § 172.101 HMT that were inadvertently omitted.

- Remove references to special provisions B72 and B74 in § 172.102.

- Revise special provision 138 in § 172.102 to clarify the lead solubility calculation used to classify a material as a Marine Pollutant.

- Revise the shipping paper requirements in § 172.203(e) to permit the phrase “Residue last contained” to be placed before or after the basic shipping description sequence, or for rail shipments, directly preceding the proper shipping name in the basic shipping description sequence.

- Update the training recordkeeping requirements in § 172.704 to specify that a hazmat employer must make hazmat employee training records available upon request, at a reasonable time and location, to an authorized official of the Department of Transportation or of an entity explicitly granted authority to enforce the HMR.

- Clarify that the material of trade exception in § 173.6 may be used when transporting Division 2.1 and 2.2 gases in Dewar flasks.

- Clarify the lab pack provisions in § 173.12 pertaining to temperature-controlled materials contained in a lab pack.

- Clarify the exceptions for external emergency self-closing valves on CTMVs in § 173.33(g) to specify that external emergency self-closing valves on MC 338 cargo tanks containing cryogenic liquids may remain open during transportation.

- Correct an inadvertent deletion of the § 173.62 packaging requirements for explosives.

- Incorporate special permit DOT SP–13556 into § 173.134, to authorize the transportation by motor vehicle of certain regulated medical wastes, designated as sharps, in non-DOT specification containers fitted into wheeled racks.

- Revise the requirements for cargo air transport of alcoholic beverages § 173.150 to harmonize with the ICAO TI.

- Clarify the exceptions in § 173.159a for non-spillable batteries secured to skids or pallets.

- Correct regulatory citations in § 178.2(c).

- Clarify the requirements for the Flame Penetration Resistance test specified for chemical oxygen generators and certain compressed gases in Appendix E to Part 178.

- Clarify the inspection record requirements in § 180.416 for discharge systems of cargo tanks transporting liquefied compressed gases.

Designated Agents for Non-Residents

Currently, § 105.40 prescribes the requirements for designated agents for non-residents. In specific instances, such as the approval of fireworks manufactured by a foreign entity, the HMR require non-residents of the United States who perform hazmat operations within the United States to designate a permanent resident of the United States to act as an agent and receive documents on behalf of the non-resident. As specified in the HMR, non-residents of the United States must prepare a designation notification and file it with PHMSA in accordance with § 105.40.

The HMR only permit designated agent notification documents to be mailed to the Approvals and Permits Division, PHMSA, Attn: PHH-30, U.S. Department of Transportation, East Building, 1200 New Jersey Avenue SE., Washington, DC 20590-0001, as specified in § 105.40(d). Revising this requirement to allow an agent designation to be transmitted by electronic mail would provide greater regulatory flexibility and align the submission of these documents with the procedures currently in place for the submission of other documents required by PHMSA.

In the April 26, 2012 NPRM, PHMSA proposed to amend § 105.40(d) to permit agent designations to be submitted by electronic mail to the special permits or approvals office, as appropriate. The option to submit a completed agent designation to the Approvals and Permits Division by mail would remain unchanged.

PHMSA received no comments on the proposed change to the requirements for designated agents for non-residents. Therefore, we are adopting these amendments to § 105.40(d), as proposed in the NPRM.

Molten Sulphur Tank Rail Car Guidance Document

Section 171.7 lists all standards incorporated by reference into the HMR and informational materials not requiring incorporation by reference. The informational materials not requiring incorporation by reference are noted throughout the HMR and provide best practices and additional safety measures that are not mandatory but, may enhance safety and compliance.

The Sulphur Institute (TSI) represents the sulfur industry in the United States on a variety of issues including the safe transportation of sulfur in commerce. TSI submitted petition P-1581 (Docket Number PHMSA-2007-28054) requesting that PHMSA incorporate by

reference TSI's "Molten Sulphur Tank Rail Car Guidance Document." This document provides best practices for the safe transport of molten sulfur in rail tank cars. TSI also requested that we amend § 173.24(b)(4) to add the sentence "Dried residue of molten sulfur on tank cars shall meet the 'Molten Sulphur Rail Car Guidance Document' incorporated by reference in § 171.7."

In the NPRM published on April 26, 2012, PHMSA proposed to adopt "Molten Sulphur Rail Tank Car Guidance" in the list of informational materials not requiring incorporation by reference in § 171.7(b). In addition, PHMSA proposed to revise the entries for "Sulfur, Molten" specified in the § 172.101 HMT to reference special provision "R1" and add special provision "R1" to the R codes specified in § 172.102(c)(6). This new special provision will recommend the use of the Molten Sulphur Rail Tank Car Guidance document when transporting "Sulfur, Molten" residues by rail; however, it will not make its use mandatory. PHMSA did not propose adding TSI's suggested language "Dried residue of molten sulfur on tank cars shall meet the 'Molten Sulphur Rail Car Guidance Document' incorporated by reference in § 171.7" to § 173.24(b)(4).

PHMSA received eight comments on the proposed addition of the "Molten Sulphur Rail Tank Car Guidance" to the list of informational materials not requiring incorporation by reference and subsequent addition of special provision "R1." Seven of these comments expressed support: KOCH, Oxbow, PCS, TFI, Transammonia, TSI, and UTCC. KOCH, who ships more than 500,000 tons of sulfur annually; Oxbow, who ships over 13,000 railcars of molten sulfur annually; PCS who receives 1.6 million tons of sulfur annually; Transammonia, who ships over 2,500 railcars of molten sulfur annually; and UTCC, who provides the means of transporting sulfur in approximately 1,100 tank cars, note that they all assisted in developing this document and believe it will benefit carriers, government inspectors, and shippers by promoting safer handling practices. TFI, a national trade association representing fertilizer importers, producers, retailers and wholesalers, reiterates the comments of these companies. In addition to expressing support for the adoption of this document, one commenter, TSI, offers two minor editorial changes to the proposed regulatory text. Specifically, TSI requests PHMSA update the mailing address listed for TSI and that PHMSA

revise the edition listed for the document.

In contrast, the AAR, on behalf of itself and its member railroads, provided comments that strongly oppose the proposed amendment. AAR states its belief that the TSI guidance contradicts certain requirements specified in the HMR. Specifically, AAR notes that § 173.24(b)(4) specifies "there will be no hazardous materials residue adhering to the outside of a package during transport." Furthermore, § 174.57 specifies "all hazardous material which has leaked from a package in a rail car or on railroad property must be carefully removed." AAR states that §§ 173.24(b)(4) and 174.57 appear to directly contradict the TSI guidance which permits residue on the outside of a rail car and only cautions against the presence of excessive residue.

AAR notes that even small amounts of molten sulfur residue can generate significant concentrations of sulfur dioxide (SO₂), and sulfur trioxide (SO₃) which are both known eye and respiratory irritants, and hydrogen sulfide (H₂S), which has demonstrated the ability to act as a nervous system toxin. Finally, AAR expresses concern that the presence of an "acceptable" level of molten sulfur residue on the outside of the rail car may cause emergency response actions when they are not necessary.

PHMSA appreciates the comments received regarding this proposed amendment. PHMSA agrees with AAR that §§ 173.24(b)(4) and 174.57 specify that no hazardous materials residue is permitted to adhere to the outside of a package during transport and that all hazardous material that has leaked from a package in a rail car or on railroad property must be carefully removed. However, PHMSA believes that minimal levels of sulfur residue on the outside of a rail tank car pose minimal transportation risk due to physical state, chemical properties, and amount. PHMSA also recognizes the difficulty in removing dried sulfur residue while in transportation.

PHMSA does not dispute AAR's assertion that molten sulfur emits dangerous chemicals such as H₂S, SO₂, and SO₃. However, as noted above, the dried, fully-cooled residue does not generate such concentrations of H₂S, SO₂, and SO₃ and poses little safety risk. To this end, PHMSA considers the "Molten Sulphur Rail Tank Car Guidance" to be a valuable tool for instances in which a minimal amount of residue remains on a tank car.

AAR further comments that molten sulfur residue on the outside rail car

may cause emergency response actions when they are not necessary. Residue of molten sulfur could also pose a safety risk by obscuring valuable tank car markings, labels, and stencils as well as tank car safety appliance features, such as ladders. PHMSA believes that the "Molten Sulphur Rail Tank Car Guidance" provides information on when the cleaning and removing of this residue is necessary, thus decreasing the likelihood that the residue will obscure hazardous materials communication or safety features or result in unnecessary emergency response actions.

PHMSA notes that the majority of comments for the adoption of the "Molten Sulphur Rail Tank Car Guidance" in the list of informational materials not requiring incorporation by reference in § 171.7(b) were positive and believes this adoption would be beneficial to carriers, government inspectors, and shippers. PHMSA further emphasizes that recognition of this document would not impose any new requirements. Instead, it would be adopted into the list of informational materials *not* requiring incorporation by reference, and therefore, would be provided for guidance purposes only. Therefore, PHMSA is adopting these amendments to §§ 171.7(b) and 172.102(c)(6) as proposed in the NPRM with the minor editorial changes identified by TSI.

Hazardous Materials Table (HMT) Revisions

The HMT in § 172.101 contains information regarding the transport conditions, proper shipping name, hazard class and division, identification number, packing group, label codes, special provisions, authorized expectations, non-bulk, and bulk packagings, quantity limitations and vessel stowage requirements for hazardous materials. Accurate information in the HMT is essential for the safe shipment of hazardous materials by all modes.

In the NPRM published on April 26, 2012, PHMSA proposed a number of revisions to the § 172.101 HMT, and the special provisions specified in § 172.102 to clarify the regulations, correct inadvertent errors, and improve the accuracy of the information contained in the HMT. The amendments to the § 172.101 HMT proposed in the April 26, 2012 NPRM included:

- Remove the Packing Group II and III entries for the proper shipping name, "Hydrazine dicarbonic acid diazide" in the § 172.101 HMT and clarify that "Hydrazine dicarbonic acid diazide" is forbidden.

- Remove the proper shipping name, "Zinc ethyl, see Diethylzinc" since "UN1366 Diethylzinc" is no longer listed in the § 172.101 HMT. Individuals offering "Zinc ethyl" should choose one of the more appropriate generic entries for organometallic compounds and substances.

- Add the entries for "Paint related material, flammable, corrosive (including paint thinning or reducing compound)" UN3469, PG II, and PG III.

- Remove Special provision B72 from Column (7) for the following entries:

- UN2484 tert-Butyl isocyanate;
- UN3492 Toxic by inhalation liquid, corrosive, flammable, n.o.s. *with an inhalation toxicity lower than or equal to 200 ml/m3 and saturated vapor concentration greater than or equal to 500 LC50*;

- UN3488 Toxic by inhalation liquid, flammable, corrosive, n.o.s. *with an LC50 lower than or equal to 200 ml/m3 and saturated vapor concentration greater than or equal to 500 LC50*; and

- UN3490 Toxic by inhalation liquid, water-reactive, flammable, n.o.s. *with an LC50 lower than or equal to 200 ml/m3 and saturated vapor concentration greater than or equal to 500 LC50*.

- Remove Special provision B74 from Column (7) for the following entries:

- NA2927 Ethyl phosphonothioic dichloride, anhydrous;

- NA2845 Ethyl phosphonous dichloride, anhydrous *pyrophoric liquid*;

- NA2927 Ethyl phosphorodichloridate;

- NA2845 Methyl phosphonous dichloride, *pyrophoric liquid*;

- UN1831 Sulfuric acid, fuming *with 30 percent or more free sulfur trioxide*;

- UN3489 Toxic by inhalation liquid, flammable, corrosive, n.o.s. *with an LC50 lower than or equal to 1000 ml/m3 and saturated vapor concentration greater than or equal to 10 LC50*; and

- UN3491 Toxic by inhalation liquid, water-reactive, flammable, n.o.s. *with an LC50 lower or equal to 1000 ml/m3 and saturated vapor concentration greater than or equal to 10 LC50*.

- Revise the entries for "Sulfur, Molten" specified in the § 172.101 HMT to reference special provision "R1."

PHMSA received nine comments on these proposed revisions. Specifically, ACA supported the proposed addition of inadvertently omitted entries for "Paint related material, flammable, corrosive (including paint thinning or reducing compound)" UN3469, PG II, and PG III. ACA noted it supports "this proposed amendment and [is] pleased to see that this correction is being addressed."

The eight other comments regarding these proposed revisions were related to

the proposed revision of the entries for "Sulfur, Molten" specified in the § 172.101 HMT to reference special provision "R1." Those comments are addressed above in the section entitled *Molten Sulphur Tank Rail Car Guidance Document*. Based on the aforementioned discussion, revision of the entries for "Sulfur, Molten" specified in the § 172.101 HMT to reference special provision "R1" will be adopted in this final rule.

PHMSA did not receive any other comments on the proposed revisions to the § 172.101 HMT as the revisions proposed in the April 26, 2012 NPRM were primarily editorial in nature or simply correcting inadvertent errors in the HMT. Therefore, based on the above comments and no opposition to any of the other editorial amendments, PHMSA is adopting these amendments to the § 172.101 HMT as proposed in the NPRM.

Special Provision Revisions

The special provisions listed in column (7) of the § 172.101 HMT contain packaging provisions, prohibitions, exceptions from requirements for particular quantities or forms of materials, and requirements or prohibitions applicable to specific modes of transportation. In the April 26, 2012 NPRM, PHMSA proposed revisions to the special provisions specified in § 172.102 to clarify the regulations and correct inadvertent errors. The amendments to the special provisions contained in § 172.102 proposed in the April 26, 2012 NPRM included:

- Add special provision "R1" to the R codes specified in § 172.102(c)(6). This new special provision will reference the "Molten Sulphur Rail Tank Car Guidance" document as a resource for best practices for the cleaning of tank cars containing "Sulfur, Molten", where product has spilled and dried on the exterior surface of the tank car.

- Revise special provision 138 specified in § 172.102(c)(1) to harmonize the HMR with the International Maritime Dangerous Goods (IMDG) code and to clarify that the solubility calculation provided in special provision 138 should be applied when determining when to use the "lead compounds, soluble n.o.s." entry in the List of Marine Pollutants found in § 172.101, Appendix B.

PHMSA received nine comments on these proposed amendments. Eight of those comments are related to the proposed addition of special provision R1 and are addressed above in the section entitled *Molten Sulphur Tank*

Rail Car Guidance Document. Based on those comments special provision R1 specified in § 172.102 will be adopted in this final rule.

PHMSA received one comment on the proposed revision of special provision 138 specified in § 172.102. In its comment, IVODGA supports the proposed amendment which revises special provision 138 to clarify the solubility calculations to be used for classification and identification of lead compounds and to harmonize the HMR provisions with the IMDG Code SP 199. Specifically, IVODGA welcomes the corrections to the § 172.101 HMT to include the provisions of HM-215 rulemakings which maintain alignment with the international standards for the listed proper shipping names, hazard classes, packing groups, special provisions, and vessel stowage requirements. PHMSA did not receive any adverse comments to this proposed amendments, and is adopting the revision of special provision 138 specified in § 172.102 as proposed in the NPRM.

Shipping Paper Requirements for Rail Shipments of Residues

On December 29, 2006, PHMSA published a final rule under PHMSA-06-25476 (HM-215I) [71 FR 78595] that permitted the continued use, for domestic shipments, of either one of two shipping description sequences in effect in the HMR on December 31, 2006, until January 1, 2013. Specifically, the HMR authorize the basic description of a hazardous material to consist of either the identification number first, followed by the proper shipping name, hazard class, and packing group, or as an alternative description sequence, the proper shipping name, hazard class, ID number and packing group. In addition, the basic description described above and specified in paragraphs § 172.202(a)(1)-(4) must be shown in the sequences described with no additional information interspersed. After January 1, 2013, only the basic shipping description sequence consisting of the identification number first, followed by the proper shipping name, hazard class, and packing group (in that order) is authorized.

However, § 172.203 provides allowances for a shipping paper to contain information in addition to the basic shipping description specified in § 172.202. Specifically, § 172.203(e)(1) permits that the shipping paper for a packaging containing the residue of a hazardous material may include the words “RESIDUE: LAST CONTAINED * * *” in association with the basic description of the hazardous material

last contained in the packaging. Further, the shipping papers for tank cars containing the residue of a hazardous material must include the phrase, “RESIDUE: LAST CONTAINED * * *” before the basic description. While the HMR provide a general provision, various international standards provide more specific guidance on the location of this phrase. Currently, the ICAO TI, IMDG Code, and UN Model Regulations require this phrase, if used, to be placed either before or after the basic shipping description.

In the NPRM published on April 26, 2012, PHMSA proposed to revise § 172.203(e)(1) to permit the shipping paper for a packaging containing the residue of a hazardous material to include the words “RESIDUE: LAST CONTAINED * * *” before or after the basic shipping description of the hazardous material last contained in the packaging. PHMSA also proposed to remove the language “in association with” and replace it with the language “before or after” to align with various international standards. This proposed revision would harmonize the HMR with the ICAO TI, IMDG Code and UN Model Regulations.

For rail shipments of tank cars, § 172.203(e)(2) requires that the description on the shipping paper for a tank car containing the residue of a hazardous material must include the phrase, “RESIDUE: LAST CONTAINED * * *” before the basic description. Prior to the publication of the HM-215I final rule, the proper shipping name was the first piece of information required in the basic shipping description, and therefore, the phrase, “RESIDUE: LAST CONTAINED * * *” preceded the proper shipping name.

Effective January 1, 2013, rail shipments coming from Canada to the United States will be unable to comply with both the current requirements in the HMR for rail tank cars and the Transportation of Dangerous Goods (TDG) requirements. As stated above, after January 1, 2013, the proper shipping name will no longer be permitted to be the first piece of shipping information in the basic shipping description. Subsequently, the phrase, “RESIDUE: LAST CONTAINED * * *” will no longer immediately precede the proper shipping name. Furthermore the phrase, “RESIDUE: LAST CONTAINED * * *” may not be inserted into the basic description, as § 172.202(b) specifies the basic shipping description may not contain any additional information interspersed in the sequence described in § 172.202(a). Canada’s TDG regulations currently permit a residue of hazardous material

to be described as “Residue—Last Contained” or “Résidu—dernier contenu,” followed by the shipping name of the dangerous goods last contained in the means of containment.

To address this issue, in the April 26, 2012 NPRM, PHMSA proposed to revise § 172.203(e)(2) to require the description on the shipping paper for a tank car containing the residue of a hazardous material to include the phrase, “RESIDUE: LAST CONTAINED * * *” before or after the basic shipping description, or immediately preceding the proper shipping name.

PHMSA received one comment on this proposed amendment. IVODGA welcomes the amendment and notes that an equivalent international standard of the IMDG Code Amendment 35-10, section 5.4.1.4.3.2 requires empty uncleaned packagings, IBCs, bulk containers, portable tanks, road tank vehicles and railway tank wagons that contain the residue of dangerous goods other than Class 7 to be described by entering the words “empty uncleaned” or “residue last contained” before or after the required basic description. IVOGDA acknowledges that § 171.22 already authorizes the offering for transportation and transporting hazardous materials in accordance with the IMDG Code. However, it also notes that the inconsistency of the terminology used on shipping documents and the sequence of information is an issue for trans-modal shipments. To further harmonize the HMR with the UN Model Regulations as adopted in the IMDG Code as well as other modal specific codes, in addition to the amendments proposed in the April 26, 2012 NPRM, IVODGA suggests that PHMSA consider revising the proposed text to permit the use of either term “empty uncleaned” or “residue last contained” as either option adequately communicates the hazard.

PHMSA appreciates IVODGA’s support of this amendment as well as its clarifying suggestion with regard to the shipping paper requirements for empty packagings. As IVOGDA correctly acknowledges, § 171.22 already authorizes the offering for transportation and transporting hazardous materials in accordance with the IMDG Code and thus the use of the term “empty unclean.” As the proposals in the April 26, 2012 NPRM did not specifically address the language “empty uncleaned” and the HMR currently permits the use of a shipping paper in accordance with the IMDG code under § 171.22, PHMSA will not specifically add the term “empty uncleaned” to §§ 172.203(e)(1) and 172.203(e)(2). We are, however, adopting the amendments

to §§ 172.203(e)(1) and 172.203(e)(2) as proposed in the NPRM.

Training Record Requirements

The requirements for hazardous materials training are specified in § 172.704. This section includes a description of the applicability for hazardous materials training, the necessary components of a training program, and the recurrent training and recordkeeping requirements.

Currently, 49 CFR part 172, subpart I describes the requirements for security plans. Specifically, §§ 172.802(d) and 172.820(i)(1) require that a copy of the security plan must be maintained and that security plan documentation be made available upon request, at a reasonable time and location, to an authorized official of the Department of Transportation (DOT) or the Department of Homeland Security (DHS).

Similar to the security plan requirements, the training requirements include a recordkeeping component. Specifically, as specified in § 172.704(d), a record of current training, inclusive of the preceding three years, must be created and retained by each hazmat employer for as long as that employee is employed by that employer as a hazmat employee and for 90 days thereafter. However, unlike the security plan documentation, the HMR currently do not stipulate that the training records must be made available upon request to authorized officials of the DOT or DHS.

The Federal hazardous materials transportation law (Federal hazmat law, 49 U.S.C. 5101 *et seq.*) authorizes the Secretary of Transportation to prescribe regulations for the safe transportation of hazardous material in intrastate, interstate, and foreign commerce. The Secretary has delegated this authority to PHMSA. Authority to enforce the HMR has been delegated to the Federal Aviation Administration “with particular emphasis on the transportation or shipment of hazardous materials by air;” the Federal Railroad Administration “with particular emphasis on the transportation or shipment of hazardous materials by railroad;” PHMSA “with particular emphasis on the shipment of hazardous materials and the manufacture, fabrication, marking, maintenance, reconditioning, repair or test of multi-modal containers that are represented, marked, certified, or sold for use in the transportation of hazardous materials;” and the Federal Motor Carrier Safety Administration “with particular emphasis on the transportation or shipment of hazardous materials by highway” (CFR part 1, subpart C). In

addition, as provided in the Homeland Security Act and as defined in a Memorandum of Agreement between the DHS and the DOT, the United States Coast Guard (USCG) retained the ability to enforce the HMR with particular emphasis on the transportation or shipment of hazardous materials by vessel. Thus, enforcement of the HMR, including the training regulations, is shared among the DOT operating administrations, USCG and DHS, with each placing particular emphasis on their respective authorities.

Federal hazmat law, 49 U.S.C. 5121(b)(2), states that a person subject to this law shall make the records, property, reports, and information available for inspection when the Secretary undertakes an investigation or makes a request. The completion of training in accordance with Subpart H of Part 172 is essential for hazmat employees handling hazardous materials and ensures proper compliance with the HMR resulting in a greater level of safety. The recordkeeping requirements specified in § 172.704(d) allow for hazmat employers and PHMSA personnel to verify that only individuals knowledgeable in the applicable regulations are handling hazardous materials.

In the NPRM published on April 26, 2012, PHMSA proposed to revise § 172.704(d) to require that an employer must make hazmat employee training records required by Subpart H of Part 172 available upon request, at a reasonable time and location, to an authorized official of DOT or DHS.

PHMSA received five comments on these proposed amendments to the training record retention requirements specified in § 172.704(d). Specifically, ATA believes that the proposed record availability provision is too broad and should be limited only to those agencies charged with enforcing PHMSA’s regulations in modal transportation. ATA notes multiple DHS agencies have a reason to access the security plans specified in §§ 172.802(d) and 172.820(i)(1). However, only one DHS agency, the USCG, has a responsibility for training records specified in § 172.704(d). As an alternative ATA suggests PHMSA amend the proposed changes to 172.704(d) by limiting the disclosure requirement to those agencies outside of the Department of Transportation (DOT) that are explicitly authorized by Congress to enforce hazmat training.

ATA states this limitation is appropriate for many reasons. First, it aligns authority with enforcement requirements. Only agencies with a responsibility to enforce training

compliance have any need to determine that training requirements have been met. Other agencies should not be tempted by the authority to audit a transporter’s records for purposes other than enforcing the HMR. Parallel to this, limiting the disclosure of this information to as few parties as is practicable represents proper government care for hazmat employees’ personally identifying information. Federal law mandates that agencies take care to ensure that privacy is a paramount concern. Limiting access to only those agencies with an explicitly granted authority to enforce the HMR is in the spirit of such statutes.

In addition to the comments presented by ATA, IVODGA, DGAC, COSHTA and NTTC provided similar comments. All voiced general support for the proposal but note the language “an authorized official of the Department of Homeland Security” was too broad. IVODGA, DGAC, COSHTA, and NTTC all suggest the language be revised to indicate the USCG as the designated division of DHS with which training records must be presented upon request.

In addition to the comments above, IVODGA further asks PHMSA to consider electronic means of recordkeeping as alternatives to hard copy documents for the sake of time saving in producing records at the request of a duly authorized representative of the DOT or DHS as amended. As this proposal was not presented in the April 26, 2012 NPRM, it is considered beyond the scope of this rulemaking and will not be addressed in this final rule. However, it should be noted that PHMSA currently does not prohibit the use of electronic training records as § 172.704 does not specify the manner in which records must be maintained.

PHMSA agrees with the concerns raised by ATA, IVODGA, DGAC, COSHTA and NTTC regarding the availability of training records. Therefore, based on the comments received, in this final rule PHMSA is adopting the proposed amendments to the training record requirements specified in § 172.704(d) and will modify the text to replace the reference to an authorized official of “the Department of Homeland Security” with a reference to an authorized official “of an entity explicitly granted authority to enforce the HMR.” This will ensure that appropriate agencies, including the USCG, have access to the required training records, while limiting unnecessary review of training records and safeguarding personally identifying

information for members of the regulated community.

Dewar Flasks Transported as Materials of Trade

Section 173.6 specifies the exceptions for shipments of materials of trade. A material of trade, as defined in § 171.8 as “a hazardous material, other than a hazardous waste, that is carried on a motor vehicle for the purpose of protecting the health and safety of the motor vehicle operator or passengers; for the purpose of supporting the operation or maintenance of a motor vehicle (including its auxiliary equipment); or by a private motor carrier (including vehicles operated by a rail carrier) in direct support of a principal business that is other than transportation by motor vehicle.” Section 173.6 authorizes only specific hazard classes and quantities to use the materials of trade exception. A hazardous material that meets the definition of a material of trade and is transported by motor vehicle in conformance with § 173.6 is not subject to any other requirements of the HMR except for those explicitly set forth or referenced in § 173.6.

PHMSA recently received a request for a formal letter of interpretation pertaining to the application of the materials of trade exception (Reference No.: 10–0101). The letter expressed confusion and concern regarding whether the exception would apply to Division 2.1 and Division 2.2 compressed gas transported in Dewar flasks.

PHMSA acknowledged this requirement needs additional clarification, as we believe that increased clarity will help to ensure the intended application of the materials of trade exception. Therefore, in the NPRM, PHMSA proposed to modify § 173.6(a)(2) to clarify that Dewar flasks may be transported as materials of trade provided these materials meet all the requirements specified in § 173.6.

PHMSA received no comments on these proposed amendments to the materials of trade requirements specified in § 173.6(a)(2). Therefore, we are adopting these amendments as proposed.

Lab Packs Containing Temperature-Controlled Materials

Section 173.12 specifies the exceptions for shipment of waste materials including the requirements for waste packages known as “lab packs.” A lab pack, although not specifically defined in § 171.8, is considered a large outer packaging containing small inner packagings that are filled with various

compatible laboratory hazardous wastes. In accordance with § 173.12, a lab pack is a combination packaging consisting of a glass inner packaging, not exceeding 4 L (1 gallon) rated capacity, or a metal or plastic inner packaging, not exceeding 20 L (5.3 gallons) rated capacity. Inner packagings containing liquid must be surrounded by a chemically compatible absorbent material in sufficient quantity to absorb the total liquid contents. These inner packagings are then further packed in specification outer packaging and the completed package must not exceed a gross weight of 205 kilograms. The requirements and regulatory relief provided for the transportation of waste hazardous materials under the lab pack exception are further specified in § 173.12(b) of the HMR.

On July 17, 2007, PHMSA published a request for comments regarding the conversion of special permits into the HMR in the **Federal Register** under Docket Number PHMSA–2007–27329 (HM–233A) [72 FR 388110] entitled, “Hazardous Materials: Conversion of Special Permits into Regulations of General Applicability.” In response to this notice PHMSA received comments requesting the incorporation of various special permits including special permit DOT SP–13192. Subsequently, PHMSA published in the **Federal Register** under Docket Number PHMSA–2009–27289 (HM–233A) [74 FR 68004] an NPRM entitled, “Hazardous Materials: Incorporation of Special Permits Into Regulations” proposing the incorporation of special permit DOT SP–13192. The lab pack requirements were then amended in a final rule published on May 14, 2010, in the **Federal Register** under Docket Number PHMSA–2009–0289 (HM–233A) [74 FR 53413] entitled, “Hazardous Materials: Incorporation of Special Permits into Regulations.” As part of these amendments, certain widely used and longstanding special permits, including special permit DOT SP–13192, were incorporated into the HMR. Specifically, the incorporation of this special permit authorized the transport of waste Division 4.2, Packing Group (PG) I material and Division 5.2 (organic peroxide) material in lab packs.

PHMSA recently received a request for a formal letter of interpretation pertaining to the recent changes of the lab pack exception (Reference No.: 10–0233). The writer expressed confusion and concern regarding whether the amendments of the HM–233A final rule authorized the transportation, as lab packs, of Division 4.1 and Division 5.2 materials that were also required to be temperature-controlled.

PHMSA acknowledged that this requirement needed additional clarification, as we believe that increased clarity will help to ensure that individuals transporting lab packs containing temperature-controlled materials are aware that such packagings are not excepted from other safety measures. Therefore, in the NPRM, PHMSA proposed to modify § 173.12 to clarify that temperature-controlled materials may be transported in lab packs provided these materials also meet the requirements in § 173.21(f)(1). PHMSA received one comment on this proposed amendment. Veolia commented that “PHMSA’s incorporation of the clarification to require shippers to also comply with operational controls for the transportation of temperature controlled materials in § 173.21(f)(1) is greatly appreciated.” Veolia did however note that it has additional safety concerns involving the shipment of Division 5.2 materials under the lab pack exception stemming from the adoption of the amendments of HM–233A that it believes PHMSA should also address. These additional safety concerns related to the HM–233A final rule were beyond the scope of this rulemaking and thus not addressed in this final rule. Therefore, we are adopting as proposed the amendment to clarify that temperature-controlled materials may be transported in lab packs provided these materials also meet the requirements in § 173.21(f)(1).

Cargo Tank Motor Vehicles Self-Closing Stop Valves

Section 173.33 provides the requirements for hazardous materials transported in CTMVs. This section includes general requirements for CTMVs, as well as more specific requirements for loading, maximum lading pressure, relief systems, and closing valves.

Section 173.33(g) requires each liquid filling and liquid discharge line in a specification MC 338 cargo tank must be provided with a remotely-controlled internal self-closing stop valve except when the MC 338 cargo tank is used to transport argon, carbon dioxide, helium, krypton, neon, nitrogen, or xenon.

The discharge control device requirements for a MC 338 cargo tank are found in § 178.338–11(b) and state that each liquid filling and liquid discharge line must be provided with a shut-off valve located as close to the tank as practicable and, unless the valve is manually operable at the valve, the line must also have a manual shut-off valve.

PHMSA received a request for a formal letter of interpretation regarding the current requirements for MC 338 cargo tanks (Reference No.: 06-0243). According to the request, most vacuum insulated MC 338 cargo tanks operate at temperatures below the reliable operating temperature of available internal self-closing stop valves, and currently no manufacturer builds an internal self-closing stop valve that will operate reliably at temperatures that may reach minus 452 °F. The requestor asked if a MC 338 cargo tank is required to have a remotely-controlled internal self-closing stop valve as specified in § 173.33(g), provided an external stop valve is present in accordance with § 178.338-11(b).

PHMSA does not intend to require a remotely-controlled internal self-closing stop valve if the MC 338 cargo tank already uses an external self-closing stop valve to meet the requirements in § 178.338-11(b). Therefore, in the NPRM, we proposed to revise the provisions in § 173.33(g) to clarify this exception.

PHMSA received no comments on these proposed amendments to the requirements for CMTV Self-Closing Stop Valves specified in § 173.33(g), and are adopting these amendments as proposed.

Explosive Packaging Editorial Revision

Section 173.62 specifies packaging requirements for explosives. Specifically, § 173.62 provides a table that specifies the packaging instructions, and corresponding authorized inner, intermediate and outer packagings based on the assigned identification number of the explosive.

In a final rule published on September 13, 2011, under Docket Number PHMSA-2011-0134 (HM-244D) [76 FR 56304], entitled "Minor Editorial Corrections and Clarifications," PHMSA revised § 173.62(c)(5) packaging instruction 130 to authorize the use of aluminum boxes (4B) and natural wood, sift-proof walls boxes (4C2). However, the following language was inadvertently removed from the first column of the packing instruction:

"2. Subject to approval by the Associate Administrator, large explosive articles, as part of their operational safety and suitability tests, subjected to testing that meets the intentions of Test Series 4 of the UN Manual of Tests and Criteria with successful test results, may be offered for transportation in accordance with the requirements of this subchapter."

PHMSA did not intend to remove this portion of the packaging instruction and unnecessarily limit the transport of large

explosive articles. Therefore, in the April 26, 2012 NPRM, PHMSA proposed to revise § 173.62(c)(5) packing instruction 130 to reinstate the language inadvertently removed from the first column of packing instruction 130.

PHMSA received no comments on these proposed amendments to the explosive packaging instruction 130 in § 173.62(c)(5). Therefore, we are adopting this amendment as proposed in the NPRM.

Exclusive Use Vehicles for Regulated Medical Waste (RMW)

Section 173.134 provides definitions and exceptions for infectious substances. Paragraph (c)(2) of this section requires a Regulated Medical Waste (RMW) that contains Category B cultures and stocks to be transported on a vehicle "used exclusively" to transport RMW. A Category B substance is defined as "an infectious substance that is not in a form generally capable of causing permanent disability or life-threatening or fatal disease in otherwise healthy humans or animals when exposure to it occurs."

As amended on July 20, 2011, in a final rule published under Docket Number PHMSA-2009-0151 (HM-218F) [76 FR 43510], entitled "Miscellaneous Amendments," PHMSA revised § 173.134(c)(2) to incorporate the clarifications from a March 19, 2007 letter of interpretation (Ref. No. 07-0057). Specifically, PHMSA specified that the following materials may be transported on a vehicle used exclusively to transport RMW: (1) Plant and animal waste regulated by the Animal and Plant Health Inspection Service (APHIS); (2) waste pharmaceutical materials; (3) laboratory and recyclable wastes; (4) infectious substances that have been treated to eliminate or neutralize pathogens; (5) forensic materials being transported for final destruction; (6) rejected or recalled health care products; and (7) documents intended for destruction in accordance with Health Insurance Portability and Accountability Act of 1996 (HIPAA) requirements.

In response to the proposals in the HM-218F NPRM, Stericycle commented that the rationale underlying PHMSA's decision to authorize the transportation of multiple waste streams from medical facilities should also apply to other regulated activities, specifically to those covered under special permit DOT SP-13556, which authorizes the transportation of sharps in specialized containers. At the time of the July 20, 2011 final rule, PHMSA determined that incorporating special permit DOT SP-

13556 into the HMR was beyond the scope of that rulemaking, but this issue would be addressed in a future NPRM. Therefore, in the NPRM published on April 26, 2012 PHMSA proposed to revise § 173.134(c)(2) to incorporate special permit DOT SP-13556 relating to the transport of regulated medical waste into the HMR.

PHMSA received one comment from Stericycle expressing full support for this proposal. Stericycle did not suggest edits to the regulatory text incorporating DOT-SP 13556. Therefore, we are adopting this amendment as proposed in the NPRM. Furthermore, we are reinstating the text previously adopted in the HM-218F final rule published under Docket Number PHMSA-2009-0151 (HM-218F) [76 FR 43510] as it was inadvertently deleted from the HMR.

However, Stericycle did express its belief that the definition of sharps specified in § 173.134 (a)(6) should be amended to include unbroken glass contaminated with a pathogen or that could become contaminated with a pathogen so the regulated community has a better understanding of the definition of sharps. Although PHMSA agrees that a clarification of the definition of "sharps" may assist the regulated community in understanding the applicable requirements, such a revision is beyond the scope of the original proposed amendments and will not be addressed in this final rule.

Alcoholic Beverages Exception

Section 173.150 provides exceptions from the HMR for certain Class 3 flammable liquid material. Specifically, § 173.150(d) provides exceptions for alcoholic beverages for all modes of transport. An alcoholic beverage (wine and distilled spirits as defined in 27 CFR 4.10 and 5.11) that meets one of three conditions specified in § 173.150(d) is not subject to the requirements of the HMR for a Class 3 flammable liquid material. These conditions include; (1) Containing 24 percent or less alcohol by volume; (2) being packaged in an inner packaging of 5 L (1.3 gallons) or less, and for transportation on passenger-carrying aircraft conforming to § 175.10(a)(4) as checked or carry-on baggage; or (3) for a Packing Group III alcoholic beverage being packaged in a packaging of 250 L (66 gallons) or less, unless transported by air.

Currently, the ICAO TI provide exceptions for alcoholic beverages transported via aircraft in Chapter 3; 3.1.1, Table 3-2, special provision A9 and Chapter 8; 8.1.2 paragraph (I). Specifically, Chapter 3; 3.1.1 Table 3-2 special provision A9 states that

alcoholic beverages containing not more than 70 percent alcohol by volume, when packaged in receptacles of 5 liters or less are not subject to the ICAO TI when carried as cargo. In addition, as specified in Chapter 8; 1.1.2 paragraph (l) of the ICAO TI, alcoholic beverages with less than 24 percent alcohol by volume or alcoholic beverages in retail packaging and alcoholic beverages containing more than 24 percent but not more than 70 percent alcohol by volume in receptacles not exceeding 5 liters are permitted to be carried by passengers or crew in carry-on or checked luggage and are not otherwise subject to the ICAO TI.

Generally, the HMR is harmonized with the ICAO TI with regard to the exceptions provided for alcoholic beverages shipped by passenger carrying and cargo aircraft. However, for cargo aircraft, the HMR does not align with the ICAO TI. For example, as specified in § 173.150(d), the HMR excepts alcoholic beverages in an inner packaging of 5 L (1.3 gallons) or less from regulation regardless of the alcohol percent on cargo aircraft. In contrast, the ICAO TI limits this exception to alcoholic beverages not exceeding 70 percent alcohol by volume. This lack of harmonization can lead to frustration of shipments of these types of materials in international air transport.

To address this issue, in the April 26, 2012 NPRM, PHMSA proposed to revise the exceptions in § 173.150(d) to harmonize the alcoholic beverages exception via aircraft with the requirements in the ICAO TI, and to restructure the exceptions in § 173.150(d) to provide clarity on the requirements for the transport of alcoholic beverages by each mode of transport including passenger carrying and cargo aircraft.

PHMSA received one comment on these proposed amendments. COSTHA strongly supports this and other international harmonization efforts. However, COSTHA believes the revisions to § 173.150, as proposed in the NPRM, prohibit the exception from being applied to alcohol shipped as cargo on passenger aircraft. The proposed text in § 173.150(d)(2)(iii) states alcoholic beverages transported aboard a cargo aircraft containing more than 24 percent but less than 70 percent alcohol by volume in an inner packaging of 5L (1.3 gallons) or less are not subject to the requirements of Subchapter C of the HMR. COSTHA notes that ICAO SP A9 states “[a]lcoholic beverages containing not more than 70 per cent alcohol by volume, when packed in receptacles of 5 litres or less, are not subject to these

instructions when carried as cargo.” In the ICAO TI, the word ‘cargo’ does not mean cargo aircraft, but is defined in ICAO 3.1 as “any property carried on an aircraft (passenger or cargo) other than mail and accompanied or mishandled baggage.” Therefore in an effort to fully harmonize COSTHA recommends PHMSA modify the language in the proposed § 173.150(d)(2)(iii) to remove the word “cargo” before aircraft allowing harmonization with the ICAO TI for alcoholic beverages on aircraft, both passenger and cargo.

PHMSA appreciates COSTHA’s comments and its general support for the amendments. On a passenger carrying aircraft an alcoholic beverage could be transported in three specific scenarios: (1) As carry-on baggage, (2) in checked baggage, or (3) as cargo. The language proposed in the NPRM addressed the first two of these transport scenarios but neglected to account for alcoholic beverages shipped as cargo aboard a passenger carrying aircraft. PHMSA did not intend to prohibit the alcoholic beverage exception from being applied to alcohol being shipped as cargo on passenger aircraft. PHMSA agrees with the statement that ICAO SP A9 states “[a]lcoholic beverages containing not more than 70 per cent alcohol by volume, when packed in receptacles of 5 litres or less, are not subject to these instructions when carried as cargo” regardless of whether it is a passenger carrying or cargo carrying aircraft. Therefore, we are revising the proposed language in § 173.150(d)(2)(iii) so that the exception for alcoholic beverages containing more than 24% but less than 70% alcohol by volume in an inner packaging not exceeding 5 L (1.3 gallons) may be transported as cargo aboard both passenger and cargo aircraft. We also note that when carried as cargo aboard a passenger carrying aircraft, the passenger provisions of § 175.10(a)(4) would no longer be applicable.

PHMSA is confident the revised text correctly reflects all transportation scenarios for alcoholic beverages and the exceptions provided for both passengers transporting alcoholic beverages via carry-on or checked baggage and transport of alcoholic beverages as cargo via cargo and passenger aircraft. Therefore, we are adopting these amendments as proposed in the NPRM, with the additional revision of § 173.150(d)(2)(iii).

Exceptions for Non-Spillable Batteries

Section 173.159 specifies requirements for the transportation of wet batteries, including non-spillable

batteries. Additional exceptions for non-spillable batteries are specified in § 173.159a. If certain transport conditions specified in §§ 173.159 and 173.159a are met, such as specific packaging and securement requirements, non-spillable batteries are excepted from the HMR.

In a final rule published on January 14, 2009, under Docket Nos. PHMSA–2007–0065 (HM–224D) and PHMSA–2008–0005 (HM–215J) [74 FR 2200], entitled “Hazardous Materials: Revision to Requirements for the Transportation of Batteries and Battery-Powered Devices; and Harmonization With the United Nations Recommendations, International Maritime Dangerous Goods Code, and International Civil Aviation Organization’s Technical Instructions,” PHMSA amended § 173.159(f) to describe the conditions under which a battery is considered “non-spillable,” and relocated the exceptions pertaining to non-spillable batteries from §§ 173.159(d) and 173.159(f), to a new § 173.159a.

However, when these exceptions were relocated, PHMSA inadvertently required that excepted non-spillable batteries must be securely packaged in strong outer packagings. This modification, in essence, prohibited excepted batteries from being palletized or placed on a skid. Therefore, in the NPRM published on April 26, 2012, PHMSA proposed to revise § 173.159a(c)(1) to except from the packaging requirements of § 173.159, non-spillable batteries that are secured to skids or pallets and capable of withstanding the shocks normally incident to transportation, provided the batteries meet the requirements of § 173.159(a) and are loaded or braced so as to prevent damage and short circuits in transit. Further, any other material loaded in the same vehicle must be blocked, braced, or otherwise secured to prevent contact with or damage to the batteries.

PHMSA received one comment on these proposed amendments to the exceptions for non-spillable batteries specified in § 173.159a(c)(1). IVODGA welcomes the clarification of the exceptions in § 173.159a for non-spillable batteries secured to skids or pallets which align the HMR with the requirements and exceptions within the IMDG Code and supports the ongoing efforts to reduce frustrated shipments in multi-modal commerce by international carriers such as the IVODGA membership.

However, IVODGA expresses confusion regarding the applicability of the incident reporting requirements to a shipment of batteries that meets the

exception provided in § 173.159a(d). To alleviate this perceived lack of clarity, IVODGA suggests PHMSA clarify the text in §§ 173.159a(b) and 173.159a(d) to specify whether the exception from incident reporting requirements is applicable.

Based on the current text “are subject to the incident reporting requirements” specified in § 173.159a(b) it is apparent that shipments complying with this section would be subject to the incident reporting requirements. Furthermore, § 173.159a(d) states that “Non-spillable batteries are excepted from all other requirements of this subchapter when offered for transportation and transported in accordance” with paragraph (c) and (d) of § 173.159a. The term “excepted from all other requirements of this subchapter” is used throughout the HMR to indicate that only the requirements of the paragraph in which that statement is included would apply. Paragraphs (c) and (d) of § 173.159a do not mention incident reporting requirements. Therefore, we believe it is clear that provided a shipment of non-spillable batteries meets the requirements of § 173.159a(c) and § 173.159a(d), which do not include the incident reporting requirements, it is not subject to any other requirements contained in the HMR; therefore, we are not adopting any additional suggested amendments to § 173.159a. Based on the foregoing, PHMSA is adopting the amendment to § 173.159a(c)(1), as proposed in the NPRM.

Cargo Tank Motor Vehicle Closures

Section 177.834 provides the general requirements for the loading and unloading of vehicles intended to transport hazardous materials via ground transportation. Paragraph (j) of this section requires CTMVs to be transported with all valves and other closures in liquid discharge systems to be closed and free of leaks unless transported in accordance with the requirements for empty packages specified in § 173.29(b)(2).

The provision specified in § 177.834(j) was added on May 30, 1996, in a final rule published under Docket Number HM-222B [61 FR 27166] to consolidate the closure requirements for cargo tanks transporting Class 3 (flammable liquid) materials, Class 8 (corrosive) materials, and Division 6.1 (poisonous) materials. This rule inadvertently overlooked the impact the closure requirement would have on MC 338 cargo tanks that transport cryogenic liquids. These tanks have external self-closing valves that are normally transported in an open position and are designed to close with a tremendous amount of force to ensure

proper closure. Subsequently, these valves require a large amount of force and effort to open. As a result, the potential for physical injury to employee personnel is increased and the ability of the valve system to operate is potentially compromised as a result of repeated cycling (opening, closing, and testing).

In the NPRM published on April 26, 2012, PHMSA proposed to revise § 177.834(j) to permit external emergency self-closing valves on MC 338 cargo tanks containing residues of cryogenic liquids to remain either open or closed during transit.

PHMSA received no comments on these proposed amendments to the closure requirements for external emergency self-closing valves on MC 338 cargo tanks specified in § 177.834(j), and are adopting these amendments as proposed.

Cargo Tank Motor Vehicle (CTMV) Recordkeeping

Certain CTMVs require as part of their specification both a CTMV manufacturer's data report and a certificate stating that the completed CTMV conforms in all respects to the appropriate specification and the American Society of Mechanical Engineers (ASME) Code. Section 178.2(c)(1) currently excepts CTMVs that require a manufacturer's data report and certificate from the notification requirements. Specifically, § 178.2(c)(1) states that CMTV's in compliance with §§ 178.337-18 and 178.345-10 are excepted from the notification requirements specified in § 178.2(c)(1). The current reference to § 178.345-10 in § 178.2(c)(1) refers to pressure relief, not the CTMV manufacturer's data report and certificates for DOT 406, 407 and 412 (CTMVs), and is in error. The correct citation should read § 178.345-15, which refers to the manufacturer's data report and certification of DOT 406, 407 and 412 CMTVs. In addition, we also note that a reference to a MC 338 cargo tank manufacturer's data report certificate in § 178.338-19 is missing in § 178.2(c)(1).

Therefore, in the April 26, 2012 NPRM, PHMSA proposed to correct these errors and omissions by replacing the reference to § 178.345-10 with § 178.345-15 and adding a reference to § 178.338-19.

PHMSA received one positive comment and no negative comments on the proposed amendments to the recordkeeping requirements for CTMV specified in § 178.2(c)(1). DGAC supports such an amendment. This revision will increase compliance by revising incorrect citations and

correcting unintended errors in the HMR. Therefore, we are adopting these clarifications as proposed in the NPRM.

Flame Penetration Resistance Test

Appendix E to Part 178 describes the Flame Penetration Resistance Test referenced throughout the HMR with regard to the outer packaging for chemical oxygen generators and cylinders containing compressed oxygen. This appendix specifies requirements for the Flame Penetration Resistance Test and includes criteria for acceptance of a passing test result, a summary of the test method and procedure, details on the preparation of test specimens, and construction and calibration specifications for the test equipment. The test procedure is described in section (g)(2) of this Appendix and references a “Figure 1,” However, the Figure 1 is omitted. In sections (d)(3) and (f)(2) of this Appendix, the design and calibration of the calorimeter is described and refers to a “Figure 2,” but Figure 2 is also omitted.

In the April 26, 2012 NPRM, PHMSA proposed to add Figures 1 and 2 that were referenced but inadvertently omitted from Appendix E.

PHMSA received no comments on the proposed addition of the figures inadvertently omitted in Appendix E to Part 178, and is adopting these amendments as proposed in the NPRM.

Discharge System Inspection and Maintenance Program

Section 180.416 details the requirements for a discharge system inspection and maintenance program for cargo tanks transporting liquefied compressed gases. Specifically, § 180.416 applies to operators using specification MC 330, MC 331, and non-specification cargo tanks authorized under § 173.315(k) for transportation of liquefied compressed gases other than carbon dioxide. As part of the discharge system inspection specified in this section, the operator must visually inspect each delivery hose assembly at least once each calendar month in which the delivery hose assembly is in service and keep a record of each inspection. In accordance with § 180.416(d), that record must include the inspection date, the name of the person performing the inspection, the hose assembly identification number, the company name, the date the hose was assembled and tested, and an indication that the delivery hose assembly and piping system passed or failed the tests and inspections.

There has been some confusion among the regulated community

pertaining to the requirement to include “the company name” in the record as specified in § 180.416(d). Specifically, there was concern over whether “the company name” refers to the name of the operator or the name of the manufacturer of the hose.

In the April 26, 2012 NPRM, PHMSA proposed to revise § 180.416(d) to clarify that the reference to the “company name” on the inspection record is the name of the hose manufacturer.

PHMSA received no comments on the proposed clarification of the discharge system inspection and maintenance program recordkeeping requirements specified in § 180.416(d), and is adopting these amendments as proposed.

C. Comments Beyond the Scope of This Rulemaking

In this section, PHMSA discusses the comments to the NPRM that provided suggestions for additional revisions that were not specifically proposed in the NPRM. Based on an assessment of the proposed changes and the comments received, PHMSA identified four comments that are beyond the scope of this rulemaking action. Specifically, these comments were submitted by Stericycle, IVODGA, Veolia, and Richard Zbilski. These comments pertain to a revision to the definition of sharps, electronic retention of training records, the lab pack revisions adopted into the HMR in a final rule entitled “Hazardous Materials: Incorporation of Special Permits into Regulations” under PHMSA–2009–0289 [70 FR 43638] (HM–233A) and published in the **Federal Register** on May 14, 2010, and the environmental impact of fireworks.

As these suggested amendments were not proposed in the NPRM and the regulated community was not given the opportunity to comment on these amendments, PHMSA is unable to address them in this final rule. If PHMSA chooses to pursue consideration of any of these comments, we will do so in a separate rulemaking. PHMSA appreciates Stericycle, IVODGA, Veolia, and Richard Zbilski bringing these issues to our attention and invites them to file petitions for rulemaking in accordance with § 106.95 including all information (see § 106.100) needed to support a petition if these commenters believe these amendments warrant rulemaking action. PHMSA briefly discusses these comments below.

Revision to the Definition of Sharps

In the April 26, 2012 NPRM, PHMSA proposed to incorporate special permit DOT SP–13556 into § 173.134, to

authorize the transportation by motor vehicle of certain regulated medical wastes, designated as sharps, in non-DOT specification containers fitted into wheeled racks. In addition to its comments regarding the incorporation of this special permit DOT SP–13556, Stericycle also submitted a comment with regard to the definition of the term “sharps” as specified in § 173.134(a)(6). Stericycle stated that the definition of “sharps” should be amended to include “unbroken glass contaminated with a pathogen or that could become contaminated with a pathogen so the regulated community has a better understanding of the definition of sharps.” Although clarification of the definition of “sharps” may assist the regulated community in understanding the applicable requirements, PHMSA has determined that such an amendment is beyond the scope of the proposals presented in the April 26, 2012 NPRM and therefore will not be addressed in this final rule.

Electronic Retention of Training Records

In addition to its comments regarding the proposed revisions to the training record requirements specified in § 172.704(d), IVODGA also requested PHMSA “consider electronic means of recordkeeping as alternatives to hard copy documents for the sake of time saving in producing records at the request of a duly authorized representative.” As this specific amendment was not proposed in the April 26, 2012 NPRM, it is considered outside the scope of this rulemaking and will not be addressed in this final rule. It should be noted that PHMSA currently does not prohibit the use of electronic training records as § 172.704 does not specify the manner (i.e. paper or electronic) in which records must be kept.

Reconsideration of the Lab Pack Requirements Adopted Under HM–233A

In addition to its comments regarding the proposed revisions to the lab pack requirements specified in § 173.12, Veolia also requested that PHMSA reconsider amendments adopted in the HMR in a final rule entitled “Hazardous Materials: Incorporation of Special Permits into Regulations” under PHMSA–2009–0289 [75 FR 27205] (HM–233A) and published in the **Federal Register** on May 14, 2010. Specifically, Veolia requests PHMSA reconsider further amending the requirements for lab pack to address various safety concerns it claims have resulted from the adoption of the HM–

233A final rule. Veolia is concerned that amendments adopted in HM–233A rulemaking will diminish the safety of the shipments of waste Division 5.2 materials for disposal by increasing the potential for misclassification of the hazardous materials by the shipper and allowing the use of a less rigorous packaging. Veolia’s specific comments can be reviewed in the docket for this rulemaking. As the revisions to the lab pack requirements Veolia references were already proposed and offered for comment in the HM–233A NPRM and later addressed in the HM–233A final rulemaking, PHMSA does not intend to revisit them in this final rule.

PHMSA believes the additional comprehensive comments from Veolia would be more appropriately addressed in a separate rulemaking specific to lab pack requirements where they can be offered for comment from the regulated community prior to adoption. We appreciate Veolia bringing its safety concerns to our attention and encourage it to file a petition for rulemaking in accordance with § 106.95 including all information (see § 106.100) needed to support a petition if it believes these amendments warrant rulemaking action.

Fireworks Containing Sulfur

PHMSA received one comment from a concerned individual regarding the pollution resulting from the use of fireworks. Specifically, the commenter expresses concern about the amount and type of pollution emitted when using fireworks. The topic of fireworks was not addressed in the April 26, 2012 NPRM, and is therefore, beyond the scope of this rulemaking. It should be noted that PHMSA published in the **Federal Register** under Docket Number PHMSA–2010–0320 [74 FR 68004] (HM–257) an NPRM entitled, “Hazardous Materials: Revision to Fireworks Approvals (RRR)” that addresses fireworks-related issues. The docket for the fireworks rulemaking can be found at <http://www.regulations.gov> under PHMSA–2010–0320 (HM–257).

D. Provisions Not Adopted in This Final Rule and Discussion of Comments

In this section, PHMSA discusses the changes proposed in the NPRM and the comments received in response to the NPRM. Based on an assessment of the proposed changes and the comments received, PHMSA identified one provision that we are not adopting in this final rule. Specifically, PHMSA received considerable negative comments on the proposed revision to the closure notification requirements. Below is a summary of the amendment proposed, the comments received, and

PHMSA's rationale for not adopting this proposed amendment.

Closure Notification Requirements

Section 178.2 specifies the applicability of the requirements to specification packagings and the responsibilities of the manufacturer or other persons certifying compliance with the specification packaging requirements of Part 178. To achieve compliance with these requirements, the manufacturer or other person certifying compliance with the requirements of Part 178 must provide both notification to each person to whom a packaging is transferred of all requirements in Part 178 not met at the time of transfer, and applicable closure requirements for the packaging. These closure requirements include information specifying the type(s) and dimensions of the closures, including gaskets and any other components needed to ensure that the packaging is capable of successfully passing the applicable performance tests. This information must include any procedures to be followed, including closure instructions for inner packagings and receptacles, to effectively assemble and close the packaging for the purpose of preventing leakage in transportation. Closure instructions must provide for a consistent and repeatable means of closure that is sufficient to ensure the packaging is closed in the same manner as it was tested.

In April 2006, PHMSA received a request (Reference No.: 06-0123) for a letter of interpretation seeking clarification of the closure notification requirements specified in § 178.2(c) for "packages" containing residues. This letter was submitted to PHMSA requesting additional clarification on two previously issued letters of interpretation (Reference Numbers 05-0015 and 05-0265) which also addressed the topic of closure requirements with regard to "packaging" and "packages." In response to Reference No. 06-0123, PHMSA indicated that "packages" containing residues must meet the notification requirements of § 178.2(c) and that we would clarify this issue in a future rulemaking.

In the April 26, 2012 NPRM, PHMSA addressed this need for clarification by proposing to revise § 178.2(c) to specify that the notification requirements apply to a packaging containing a residue of a hazardous materials unless the packaging of hazardous materials meets the exceptions provided in § 173.29(b).

PHMSA received seven comments on these proposed amendments from ACA,

AHS, DGAC, NACD, RIPA, USWA and Veolia. All of the comments were extensive and strongly opposed to the amendment proposed. The commenters addressed topics related to the proposed amendments such as the intent and applicability of § 178.2(c); impact on re-conditioners, recyclers and re-users of packagings; information collection burden; economic implications, and the safety benefit, or lack thereof. PHMSA appreciates this feedback and an overview of these comments is provided below. The complete list of comments pertaining to this amendment is available in the docket for this rulemaking.

Several commenters disagree with the proposed amendments to the closure notification requirements stating that the changes did not reflect the initial intent and applicability of § 178.2(c). DGAC, whose membership includes virtually all sectors of the hazmat transportation industry, correctly noted that the term "packaging" as defined in § 171.8 and used in part 178 of the HMR refers only to receptacles that do not contain hazardous material. Subsequently, § 178.2(c) would apply to individuals moving "packagings" as defined in § 171.8, and not "packages" which would include packagings containing hazardous materials. DGAC also states that the term "subsequent distributors," as used in § 178.2(c)(1), is limited to intermediaries between the packaging manufacturer and the hazmat offeror who fills the packaging with hazardous material. Likewise, ACA agrees that the requirements of § 178.2(c) apply to packaging manufacturers and those who perform functions described in Part 178; not subsequent transporters of previously filled packages.

Another commenter, AHS, notes that the closure requirements were originally intended to identify those tasks of a packaging manufacturer that had not been completed by that packaging manufacturer. Therefore, the filler would be aware that certain actions were still required to be completed to produce, what at the time, was DOT specification packaging (e.g. assembling and closing a knocked down fiberboard box). Furthermore, it is AHS's understanding that the primary intent of the requirement to ship an emptied package containing residue as if it were still full (See § 173.29) was to maintain the original hazard communications for the residues and not for the purposes of closure requirement notification of the packaging. AHS notes that the terms "package" and "packaging" are often incorrectly used interchangeably and suggests that this was the case in the

letter of interpretation Reference No.: 06-0123 that precipitated the proposed amendment.

In addition to the concerns about the initial intent of § 178.2(c), all commenters on this amendment express concern regarding the vast impact such an amendment would have on the regulated community, specifically re-conditioners, recyclers and re-users of packagings. It was consistently noted that this amendment would fundamentally change the way hazardous materials packages are transported and have implications throughout the transportation chain.

Many commenters had concerns about the economic impact and an increase in information collection burden. While PHMSA originally perceived this amendment as a simple clarification of an existing requirement, many commenters noted that the revision would provide new requirements and thus impose a new economic and paperwork burden. DGAC notes that the cost of such a change would be significant and the economic evaluation provided in the April 26, 2012 NPRM fails to address the associated costs. Furthermore, DGAC notes this change would require information collection as the scope of those subject to the closure notification requirements would expand. This information collection was not addressed in the April 26, 2012 NPRM. ACA states this proposed requirement will add significant costs and complexity to compliance efforts for containers that are sent for reconditioning and reuse. AHS asks that full consideration be given to the economic and paperwork impact of requiring every shipper and re-shipper of a filled package to provide and retain closure instructions. NACD notes that the operational requirements could have substantial economic impacts on chemical distributors and customers and could:

"[E]asily result in tens of thousands of dollars of additional costs for a distributor, increasing with the number of shipments. Costs would be substantial for all distributors and would result primarily from mailing closure instructions to hundreds of customers and answering numerous calls for technical assistance from many of these customers."

RIPA reiterates the above comments and notes that "[r]equiring that reconditioners be provided notifications is a costly paperwork burden with no safety benefit of any kind." In addition to the cost of the proposed amendment, many commenters were concerned that no safety issue was identified to necessitate such a change. ACA notes

that while PHMSA indicates that this requirement will increase compliance, there is no indication in the NPRM that there are incidents involving container residues that stemmed from insufficient closure or any discussion of the risk posed by residue containers. ACA concludes that there does not appear to be a significant safety risk involved in the movement of these types of shipments.

AHS notes the difficulty of implementing such a requirement. It provides an example demonstrating this difficulty by noting that for UN 4G fiberboard cartons, small UN1A2 drums, and crimped lid or friction lid pails, there is no realistic method to re-close the outer receptacle, or to provide inner liners, cushioning material, etc., for a package that usually is being discarded or recycled. AHS requests PHMSA provide incident data to ascertain whether any record of safety problems involves emptied non-bulk packaging with closures in place but not secured in accordance with the original packaging manufacturer's instructions. NACD reiterates the above comments and states "PHMSA does not provide evidence that leaking empty containers have been a safety problem."

Based on the considerable feedback and a further consideration of the closure requirements in § 178.2(c), PHMSA is not adopting the amendment to the closure notification requirements as proposed in the April 26, 2012 NPRM or any amendments to the closure notification requirements.

After further review, and as noted by numerous commenters, PHMSA rationalizes that it is apparent that the applicability of § 178.2(c) is specific to "packagings" and not "packages." As defined in § 171.8, a packaging "means a receptacle and any other components or materials necessary for the receptacle to perform its containment function in conformance with the minimum packing requirements of this subchapter" while a package "means a packaging plus its contents." Furthermore, as many commenters note, PHMSA agrees that the term "subsequent distributors" as used in § 178.2(c)(1) is intended to address intermediaries between the manufacturer and the hazmat offeror who fills the packaging with hazardous material. It is apparent that the requirement to notify each person to whom the "packaging" is transferred is the responsibility of each subsequent "packaging" distributor, not each offeror of a "package."

Furthermore, as is evident from PHMSA's review of the information collection burden associated with the

closure notification requirements, the population to which this regulation is intended to apply is restricted to packaging manufacturers and packaging distributors and not to the entirety of shippers and offerors of hazardous materials packages.

Based on the comments received, PHMSA will not be adopting any changes in the closure notification requirements specified in § 178.2(c). Subsequently, closure notification requirements would not be required to accompany a package containing a residue of a hazardous material that is transported for the purposes of re-conditioning, recycling or re-use. It was not PHMSA's intent to propose an amendment that would impose a significant additional economic and information collection burden on the regulated community. Furthermore, PHMSA did not intend to expand the applicability of § 178.2(c) beyond "packagings" to include "packages." Rather, PHMSA's intention was to address an issue previously identified in a letter of interpretation. However, based on further review and the rationale presented by commenters, we are rescinding the letter of interpretation Reference No.: 06-0123 as the letter contains incorrect information. In addition, PHMSA is also rescinding letters of interpretation Reference Numbers 05-0015 and 05-0265 as they also contain misinformation. Finally, many commenters suggest a thorough economic and safety analysis be conducted before amendments similar to those proposed in § 178.2(c) for closure notification requirements are adopted. At this time, PHMSA does not foresee the need for such analysis as no amendments are being adopted.

III. Regulatory Analyses and Notices

A. Statutory/Legal Authority for This Rulemaking

This final rule is published under authority of Federal hazardous materials transportation law (Federal hazmat law; 49 U.S.C. 5101 et seq.). Section 5103(b) of Federal hazmat law authorizes the Secretary of Transportation to prescribe regulations for the safe transportation, including security, of hazardous materials in intrastate, interstate, and foreign commerce. This final rule makes miscellaneous amendments to the HMR. In addition, this final rule corrects errors in the hazardous materials table and corresponding special provisions, clarifies the requirements for lab packing temperature controlled materials and clarifies various cargo tank provisions and revises the training requirements to require that a hazmat

employer must make hazmat employee training records available upon request to an authorized officials. These amendments clarify regulatory requirements and, where appropriate, decrease the regulatory burden without compromising the safe transportation of hazardous materials in commerce.

B. Executive Order 12866, Executive Order 13563 and DOT Regulatory Policies and Procedures

This final rule is not considered a significant regulatory action under section 3(f) of Executive Order 12866 and was not reviewed by the Office of Management and Budget (OMB). The final rule is not considered a significant rule under the Regulatory Policies and Procedures order issued by the Department of Transportation [44 FR 11034].

In this rulemaking, we amend miscellaneous provisions in the HMR to clarify the provisions and to relax overly burdensome requirements. PHMSA anticipates the amendments contained in this rule will have economic benefits to the regulated community. This final rule is designed to increase the clarity of the HMR, thereby increasing voluntary compliance while reducing compliance costs.

Executive Order 13563 is supplemental to and reaffirms the principles, structures, and definitions governing regulatory review that were established in Executive Order 12866 Regulatory Planning and Review of September 30, 1993. In addition, Executive Order 13563 specifically requires agencies to: (1) Involve the public in the regulatory process; (2) promote simplification and harmonization through interagency coordination; (3) identify and consider regulatory approaches that reduce burden and maintain flexibility; (4) ensure the objectivity of any scientific or technological information used to support regulatory action; and (5) consider how to best promote retrospective analysis to modify, streamline, expand, or repeal existing rules that are outmoded, ineffective, insufficient, or excessively burdensome.

In this final rule, PHMSA has involved the public in the regulatory process in a variety of ways. Specifically, in this rulemaking PHMSA is addressing issues and errors that were identified and tagged for future rulemaking consideration in letters of interpretation issued to the regulated community and through other correspondence with PHMSA stakeholders. In addition, PHMSA has responded to the TSI's request to incorporate a guidance document

designed to assist the sulfur industry in ensuring the safe transport of molten sulfur (P-1581). PHMSA asked for public comments based on the proposals in the NPRM and upon receipt of public comment, PHMSA has addressed all substantive comments in this rulemaking action.

The amendments in the final rule promote simplification and harmonization through interagency coordination. Specifically, in this final rule, PHMSA is simplifying the lab pack requirements, the hazardous materials table and special provisions and the requirements for cargo tank transportation. These revisions are expected to produce a safety benefit derived from the increased clarity and reduced ambiguity in the special provisions to the § 172.101 HMT, and the lab packaging and cargo tank requirements of the HMR. There are minimal additional costs. The clarity will result in net benefits.

This final rule also promotes harmonization with international standards, such as the IMDG Code, Canada's TDG requirements and the ICAO TI with regard to the handling of "Lead compounds, soluble n.o.s." via vessel, rail shipments of residue between the United States and Canada and alcoholic beverages via aircraft.

These revisions to the § 172.101 HMT will eliminate errors in the § 172.101 HMT, reduce ambiguity, harmonize the HMR with international regulations, and improve clarity. Many of these revisions were brought to PHMSA's attention through letters of interpretation requested from the regulated community. Although these revisions are minor, they are expected to produce a safety benefit derived from the increased clarity and accuracy of the text in the § 172.101 HMT.

This final rule adopts amendments that reduce the regulatory burden on the regulated community, allows for flexibility in achieving compliance and maintains an appropriate level of safety. This final rule permits flexibility in achieving compliance when transporting cargo tanks while maintaining an appropriate level of safety. This final rule also incorporates a special permit DOT SP-13556 that has a strong record of safety. Incorporating this permit into the HMR will provide wider access to the benefits of the provisions granted in this special permit, therefore, fostering greater regulatory flexibility without compromising transportation safety.

A majority of the amendments adopted in this rulemaking are simple clarifications and did not require significant scientific or technological

information. However, when necessary, PHMSA used scientific or technological information to support its regulatory action. Specifically, such data was considered when structuring alternatives on how to best deal with issues regarding the safe transport of cargo tanks and the transport of alcoholic beverages with greater than 70% alcohol by volume via cargo aircraft. This information was used in the evaluation of alternative proposals and ultimately this information determined how best to promote retrospective analysis to modify and streamline existing requirements that are outmoded, ineffective, insufficient, or excessively burdensome.

C. Executive Order 13132

This final rule was analyzed in accordance with the principles and criteria contained in Executive Order 13132 ("Federalism"). This final rule preempts state, local and Indian tribe requirements but does not adopt any regulation that has substantial direct effects on the states, the relationship between the national government and the states, or the distribution of power and responsibilities among the various levels of government. Therefore, the consultation and funding requirements of Executive Order 13132 do not apply.

The Federal hazardous material transportation law, 49 U.S.C. 5125(b)(1), contains an express preemption provision (49 U.S.C. 5125(b)) preempting state, local, and Indian tribe requirements on certain covered subjects. Covered subjects are:

- (i) The designation, description, and classification of hazardous materials;
- (ii) The packing, repacking, handling, labeling, marking, and placarding of hazardous materials;
- (iii) The preparation, execution, and use of shipping documents related to hazardous materials and requirements related to the number, content, and placement of those documents;
- (iv) The written notification, recording, and reporting of the unintentional release in transportation of hazardous materials; or
- (v) The design, manufacture, fabrication, marking, maintenance, reconditioning, repair, or testing of a packaging or container that is represented, marked, certified, or sold as qualified for use in the transport of hazardous materials.

This final rule concerns the classification, packaging, and handling of hazardous materials, among other covered subjects and as adopted preempts any state, local, or Indian tribe requirements concerning these subjects unless the non-Federal requirements are

"substantively the same" (see 49 CFR 107.202(d) as the Federal requirements.)

Federal hazardous materials transportation law provides at 49 U.S.C. 5125(b)(2) that if PHMSA issues a regulation concerning any of the covered subjects, PHMSA must determine and publish in the **Federal Register** the effective date of Federal preemption. That effective date may not be earlier than the 90th day following the date of issuance of the final rule and not later than two years after the date of issuance. PHMSA proposes the effective date of federal preemption be 90 days from publication of this final rule in this matter in the **Federal Register**.

D. Executive Order 13175

This final rule has been analyzed in accordance with the principles and criteria contained in Executive Order 13175 ("Consultation and Coordination with Indian Tribal Governments"). Because this final rule does not have tribal implications and does not impose substantial direct compliance costs on Indian tribal governments, the funding and consultation requirements of Executive Order 13175 do not apply, and a tribal summary impact statement is not required.

E. Regulatory Flexibility Act, Executive Order 13272, and DOT Procedures and Policies

The Regulatory Flexibility Act (5 U.S.C. 601 *et seq.*) requires an agency to review regulations to assess their impact on small entities unless the agency determines the rule is not expected to have a significant impact on a substantial number of small entities. This final rule amends miscellaneous provisions in the HMR to clarify provisions based on PHMSA's initiatives and correspondence with the regulated community. While maintaining safety, it relaxes certain requirements that are overly burdensome. The changes are generally intended to provide relief to shippers, carriers, and packaging manufacturers, including small entities.

Consideration of alternative proposals for small businesses. The Regulatory Flexibility Act directs agencies to establish exceptions and differing compliance standards for small businesses, where it is possible to do so and still meet the objectives of applicable regulatory statutes. In the case of hazardous materials transportation, it is not possible to establish exceptions or differing standards and still accomplish our safety objectives.

The impact of this final rule is not expected to be significant. The

amendments are generally intended to provide relief to shippers, carriers, and packaging manufactures and testers, including small entities. This relief will provide marginal positive economic benefits to shippers, carriers, and packaging manufactures and testers, including small entities however; these benefits are not at a level that can be considered economically significant. Therefore, this final rule will not have a significant economic impact on a substantial number of small entities.

This final rule has been developed in accordance with Executive Order 13272 (“Proper Consideration of Small Entities in Agency Rulemaking”) and DOT’s procedures and policies to promote compliance with the Regulatory Flexibility Act to ensure that potential impacts of draft rules on small entities are properly considered.

F. Paperwork Reduction Act

This final rule does not impose any new information collection requirements and in three instances marginally decreases the information collection burden on the regulated community. Specifically the following information collections affected by this rulemaking are:

- Office of Management and Budget (OMB) Control Number 2137–0051; Rulemaking and Special Permit Petitions: A slight reduction in information collection burden is anticipated due to the incorporation of a DOT SP–13556 into § 173.134. This permit will allow individuals more flexibility when transporting sharps and decrease the need for special permits applications when transporting sharps as regulated medical wastes.

- OMB Control Number 2137–0034; Hazardous Materials Shipping Papers and Emergency Response Information: A negligible reduction in information collection burden due to relaxation of the shipping paper description requirements for residues specified in § 172.203. Specifically, this will allow individuals more flexibility on the shipping paper descriptions when shipping waste internationally, and will correct a regulatory inconsistency between the HMR and Canadian Transportation of Dangerous Goods (TDG) regulations, fostering international transport of residues.

- OMB Control Number 2137–0557; Approvals for Hazardous Materials: A slight reduction in information collection burden is anticipated due to relaxation of approval submittal requirements specified in § 105.40. Specifically, this relaxation will permit individuals wishing to apply with PHMSA to be an approved designated

agent to submit their applications either by standard mail or electronic mail. Currently, the HMR only permits submission through standard mail. This change will result in a decrease in duplicate hard copies submitted to PHMSA as well as a decrease in the processing time for such applications.

- Although no new training recordkeeping requirements are adopted in this final rule, a minimal increase in information collection burden may be realized due to increased awareness of the training requirements resulting from the modifications specified in § 172.704. However; in accordance with 49 U.S.C. 5107(g), training records are exempted from the requirements of the paperwork reduction act.

G. Regulation Identifier Number (RIN)

A regulation identifier number (RIN) is assigned to each regulatory action listed in the Unified Agenda of Federal Regulations. The Regulatory Information Service Center publishes the Unified Agenda in April and October of each year. The RIN number contained in the heading of this document can be used to cross-reference this action with the Unified Agenda.

H. Unfunded Mandates Reform Act

This final rule does not impose unfunded mandates under the Unfunded Mandates Reform Act of 1995. It does not result in costs of \$141,300,000 or more to either state, local, or tribal governments, in the aggregate, or to the private sector, and is the least burdensome alternative that achieves the objective of the rule.

I. Environmental Assessment

The National Environmental Policy Act, 42 U.S.C. 4321–4375, requires federal agencies to analyze proposed actions to determine whether the action will have a significant impact on the human environment. The Council on Environmental Quality (CEQ) regulations require federal agencies to conduct an environmental review considering: (1) The need for the proposed action; (2) alternatives to the proposed action; (3) probable environmental impacts of the proposed action and alternatives; and (4) the agencies and persons consulted during the consideration process. PHMSA is adopting miscellaneous amendments to the HMR based on PHMSA’s own initiatives including a review of the HMR, previous letters of interpretation and special permits we issued. These amendments are intended to update, clarify, or provide relief from certain existing regulatory requirements to promote safer transportation practices;

eliminate unnecessary regulatory requirements; facilitate international commerce; and make these requirements easier to understand.

Description of Action

Docket No. PHMSA–2011–0138 (HM–218G), Final Rule

Transportation of hazardous materials in commerce is subject to requirements in the HMR, issued under authority of Federal hazardous materials transportation law, codified at 49 U.S.C. 5101 et seq. To facilitate the safe and efficient transportation of hazardous materials in international commerce, the HMR provide that both domestic and international shipments of hazardous materials may be offered for transportation and transported under provisions of the international regulations.

Adopted Amendments to the HMR

In this final rule, PHMSA is adopting amendments to:

- Permit designated agents for non-residents to submit designation requests by electronic mail in addition to traditional mail.

- Add the Sulphur Institute’s (TSI) “Molten Sulphur Rail Tank Car Guidance” document to the list of informational materials not requiring incorporation by reference in § 171.7 (Responds to petition for rulemaking P–1581).

- Revise the § 172.101 Hazardous Materials Table (HMT) to correct an error in the transportation requirements for entries listed under the proper shipping name, “Hydrazine Dicarboxylic Acid Diazide.”

- Revise the § 172.101 HMT to remove the entry for “Zinc ethyl, see Diethylzinc” that was superseded by proper shipping names adopted in a previous rulemaking.

- Add the entries for “Paint related material, flammable, corrosive (including paint thinning or reducing compound)” UN3469, PG II, and PG III to the § 172.101 HMT that were inadvertently omitted.

- Remove references to special provisions B72 and B74 in § 172.102.

- Revise special provision 138 in § 172.102 to clarify the lead solubility calculation used for classification of material as a Marine Pollutant.

- Revise the shipping paper requirements in § 172.203(e) to permit the phrase “Residue last contained” to be placed before or after the basic shipping description sequence, or for rail shipments, directly preceding the proper shipping name in the basic shipping description sequence.

- Update the training recordkeeping requirements in § 172.704 to specify that a hazardous materials (hazmat) employer must make hazmat employee training records available upon request, at a reasonable time and location, to an authorized official of the Department of Transportation or of an entity explicitly granted authority to enforce the HMR.

- Clarify that the materials of trade exception in § 173.6 may be used when transporting Division 2.1 and 2.2 gases in Dewar flasks.

- Clarify the lab pack provisions in § 173.12 pertaining to temperature-controlled materials contained in a lab pack.

- Clarify the exceptions for external emergency self-closing valves on CTMVs in § 173.33(g) to specify that external emergency self-closing valves on MC 338 cargo tanks containing cryogenic liquids may remain open during transportation.

- Correct an inadvertent deletion of the § 173.62 packaging requirements for explosives.

- Incorporate special permit DOT SP-13556 into § 173.134, to authorize the transportation by motor vehicle of certain regulated medical wastes, designated as sharps, in non-DOT specification containers fitted into wheeled racks.

- Revise the requirements for cargo air transport of alcoholic beverages § 173.150 to harmonize with the ICAO TI.

- Clarify the exceptions in § 173.159a for non-spillable batteries secured to skids or pallets.

- Revise § 178.2(c) to correct incorrect regulatory citations.

- Clarify the requirements for the Flame Penetration Resistance test required for chemical oxygen generators and certain compressed gases in Appendix E to Part 178.

- Clarify the inspection record requirements in § 180.416 for discharge systems of cargo tanks transporting liquefied compressed gases.

Alternatives Considered

Alternative (1)—No action alternative: Leave the HMR as is; do not adopt above-described amendments.

The HMR requires various updates and clarifications to correct certain omissions, and errors. This action also includes a few minor modifications to existing regulatory requirements. If PHMSA chose the no-action alternative, the public would not receive the benefit of the various updates, clarifications, and modifications to the HMR, which will provide information, enhance safety, and provide relief certain unnecessary requirements. Therefore,

PHMSA rejected the do-nothing alternative.

Alternative (2)—Preferred Alternative: Go forward with the proposed amendments to the HMR in the NPRM, as described above.

Environmental Consequences

Hazardous materials are substances that may pose a threat to public safety or the environment during transportation because of their physical, chemical, or nuclear properties. The hazardous materials regulatory system is a risk management system that is prevention oriented and focused on identifying a safety hazard and reducing the probability and quantity of a hazardous material release. Hazardous materials are categorized by hazard analysis and experience into hazard classes and packing groups. The regulations require each shipper to classify a material in accordance with these hazard classes and packing groups. The process of classifying a hazardous material is itself a form of hazard analysis. Further, the regulations require the shipper to communicate a material's hazards through use of the hazard class, packing group, and proper shipping name on the shipping paper and the use of labels on packages and placards on transport vehicles. Thus, the shipping paper, labels, and placards communicate the most significant findings of the shipper's hazard analysis. A hazardous material is assigned to one of three packing groups based upon its degree of hazard, from a high hazard, Packing Group I to a low hazard, Packing Group III material. The quality, damage resistance, and performance standards of the packaging in each packing group are appropriate for the hazards of the material transported.

Under the HMR, hazardous materials are transported by aircraft, vessel, rail, and highway. The potential for environmental damage or contamination exists when packages of hazardous materials are involved in accidents or en route incidents resulting from cargo shifts, valve failures, package failures, loading, unloading, collisions, handling problems, or deliberate sabotage. The release of hazardous materials can cause human death or injury, the loss of ecological resources (e.g. wildlife habitats), and the contamination of air, aquatic environments, and soil. Contamination of soil can lead to the contamination of ground water. Compliance with the HMR substantially reduces the possibility of accidental release of hazardous materials.

When developing potential regulatory requirements, PHMSA evaluates those

requirements to consider the environmental impact of each amendment. Specifically, PHMSA evaluates the: risk of release and resulting environmental impact; risk to human safety, including any risk to first responders; longevity of the packaging; and if the proposed regulation would be carried out in a defined geographic area, the resources, especially any sensitive areas, and how they could be impacted by any proposed regulations.

Of the regulatory changes adopted in this rulemaking, ten have been determined to be editorial. As such, these amendments have no impact on: the risk of release and resulting environmental impact; human safety; longevity of the packaging; and none of these amendments would be carried out in a defined geographic area. These editorial amendments are as follows:

- Revise the § 172.101 Hazardous Materials Table (HMT) to correct an error in the transportation requirements for entries listed under the proper shipping name, "Hydrazine Dicarboxylic Acid Diazide."

- Revise the § 172.101 HMT to remove the entry for "Zinc ethyl, see Diethylzinc" that was superseded by proper shipping names adopted in a previous rulemaking.

- Re-insert the entries for "Paint related material, flammable, corrosive (including paint thinning or reducing compound)" UN3469, PG II, and PG III in the § 172.101 HMT that were inadvertently omitted.

- Remove references to special provisions B72 and B74 in § 172.102.

- Revise special provision 138 in § 172.102 to clarify the lead solubility calculation used for classification of material as a Marine Pollutant.

- Correct an inadvertent deletion of the § 173.62 packaging requirements for explosives.

- Clarify the exceptions in § 173.159a for non-spillable batteries secured to skids or pallets.

- Revise § 178.2(c) to correct erroneous regulatory citations.

- Clarify the requirements for the Flame Penetration Resistance test specified for chemical oxygen generators and certain compressed gases in Appendix E to Part 178.

- Clarify the inspection record requirements in § 180.416 for discharge systems of cargo tanks transporting liquefied compressed gases.

The remaining non-editorial amendments are discussed in further detail and evaluated based on their overall environmental impact as follows:

- The requirement to permit designated agents for non-residents to

submit designation requests by electronic mail in addition to traditional mail does not impact positively or negatively on the risk of release, risk to human safety, or longevity of the packaging as the requirements of the special permit are designed to provide an equivalent level of safety to current regulatory requirements. Furthermore, this requirement would not be carried out in a defined geographic area including any sensitive areas.

- The adoption of the Sulphur Institute's (TSI) "Molten Sulphur Rail Tank Car Guidance" document to the list of informational materials not requiring incorporation by reference in § 171.7 makes this document a reference material only and thus would only have a minimal impact. Specifically, complying with this document will limit the obstruction of valuable tank car markings, labels, and stencils as well as tank car safety appliance features such as ladders, which may result in a minimal positive impact with regard to the risk of release and risk to human safety. PHMSA acknowledges that the presence of minimal amounts of residue on the outside of a rail tank car results in the emission of small amounts of H₂S, SO₂, and SO₃. However, the presence of this residue is a longstanding occurrence related to the shipment of molten sulfur and not related to or caused by this rulemaking. The adoption or recognition of the "Molten Sulphur Rail Tank Car Guidance" document seeks to decrease any minimal amount of risk caused by this residue. This guidance document may also have an impact on tank car cleanliness which may result in increased longevity of the packaging. In addition, this guidance document could be carried out throughout the country, and is not thought to be specific to defined geographic area that includes any sensitive areas.

- The revision of the shipping paper requirements in § 172.203(e) to permit the phrase "Residue last contained" to be placed before or after the basic shipping description sequence, or for rail shipments, directly preceding the proper shipping name in the basic shipping description sequence may have a minimal positive environmental impact. This impact would result from the diminished amount of delayed shipments between the United States and Canada and thus could diminish the risk of release, and risk to human safety. PHMSA does not anticipate that this amendment will affect the longevity of the packaging.

- PHMSA does not anticipate the requirement to update the training recordkeeping requirements in

§ 172.704 to specify that a hazmat employer must make hazmat employee training records available upon request to an authorized official of the Department of Transportation or of an entity explicitly granted authority to enforce the HMR will have any environmental impacts. PHMSA views this amendment as procedural and thus would have no impact on the risk of release, risk to human safety, or longevity of the package. Furthermore, this requirement would not be carried out in a defined geographic area including any sensitive areas.

- The amendment to permit Division 2.1 and 2.2 gases in Dewar flasks to use the Material of Trade exception specified in § 173.6 does not provide any new regulatory requirement; it simply clarifies PHMSA's interpretation of the applicability of the section.

Therefore, this amendment is a clarification and thus would have no impact on the risk of release, risk to human safety, or longevity of the package. Furthermore, this requirement would not be carried out in a defined geographic area including any sensitive areas.

- The amendment that clarifies that temperature-controlled materials meeting the lab pack requirements in § 173.12 must also comply with § 173.21(f)(1) may have a small positive environmental impact. Specifically, this amendment could provide valuable guidance that could eliminate the inclusion of incompatible materials in a lab pack and thus, lessen the risk of a release and risk to human safety. This amendment will have no impact on the longevity of the package. Furthermore, this requirement would not be carried out in a defined geographic area including any sensitive areas.

- The amendment that clarifies the exceptions for external emergency self-closing valves on CTMVs in § 173.33(g) to specify that external emergency self-closing valves on MC 338 cargo tanks containing cryogenic liquids may remain open during transportation may have a slight impact on the longevity of the CTMV closing valves. Limiting the closure of these valves could eliminate some deterioration and extend the lifespan of these CTMV valves. PHMSA also anticipates a positive impact on risk to human safety. These valves are designed to close with a tremendous amount of force to ensure proper closure. Subsequently, these valves require a large amount of force and effort to open. As a result, the potential for physical injury to employee personnel is increased and the ability of the valve system to operate is potentially compromised as a result of

repeated cycling (opening, closing, and testing). PHMSA does not anticipate any impacts on the risk of release. Furthermore, this requirement would not be carried out in a defined geographic area including any sensitive areas.

- The incorporation of special permit DOT SP-13556 into § 173.134, to authorize the transportation by motor vehicle of certain regulated medical wastes, designated as sharps, in non-DOT specification containers fitted into wheeled racks should have no environmental impact. As special permits are designed to provide an equivalent level of safety to current regulatory requirements PHMSA anticipates no impact on the risk of release, risk to human safety, or longevity of packaging. Furthermore, this requirement would not be carried out in a defined geographic area including any sensitive areas.

- The harmonization of the requirements for cargo air transport of alcoholic beverages specified in § 173.150 with the ICAO TI may have a minimal environmental impact. The international harmonization of hazardous materials regulations will discourage delayed shipments and thus could positively affect the risk of release, risk to human safety. PHMSA does not anticipate this amendment will affect the longevity of the packaging. Furthermore, this requirement would not be carried out in a defined geographic area including any sensitive areas.

Agencies Consulted

This final rule would affect some PHMSA stakeholders, including hazardous materials shippers and carriers by highway, rail, vessel, and aircraft, as well as package manufacturers and testers. PHMSA sought comment on the environmental assessment contained in the April 26, 2012, NPRM published under Docket PHMSA 2011-0138 [77 FR 24885] (HM-218G) however, PHMSA did not receive any comments on the environmental assessment contained in that rulemaking. In addition, PHMSA sought comment from the following Federal Agencies and modal partners:

- Department of Commerce
- Department of Homeland Security
- Department of Justice
- Environmental Protection Agency
- Health and Human Services
- National Institute of Science and Technology
- Occupational Safety and Health Administration
- Federal Aviation Administration

- Federal Motor Carrier Safety Administration
 - Federal Railroad Administration
- PHMSA did not receive any adverse comments on the amendments adopted in this final rule from these Federal Agencies.

Conclusion

PHMSA is adopting miscellaneous amendments to the HMR based on comments from the regulated community and PHMSA's own rulemaking initiatives. The amendments are intended to update, clarify, or provide relief from certain existing regulatory requirements to promote safer transportation practices; eliminate unnecessary regulatory requirements; facilitate international commerce; and make these requirements easier to understand. These clarifications of regulatory requirements will foster a greater level of compliance with the HMR and thus, diminished levels of hazardous materials transportation incidents affecting the health and safety of the environment. Therefore, PHMSA concludes that no significant environmental impact will result from this rule.

J. Privacy Act

Anyone is able to search the electronic form of any written communications and comments received into any of our dockets by the name of the individual submitting the document (or signing the document, if submitted on behalf of an association, business, labor union, etc.). You may review DOT's complete Privacy Act Statement in the **Federal Register** published on April 11, 2000 (65 FR 19477), which may be viewed at <http://www.gpo.gov/fdsys/pkg/FR-2000-04-11/pdf/00-8505.pdf>.

K. International Trade Analysis

The Trade Agreements Act of 1979 (Pub. L. 96-39), as amended by the Uruguay Round Agreements Act (Pub. L. 103-465), prohibits Federal agencies from establishing any standards or engaging in related activities that create unnecessary obstacles to the foreign commerce of the United States. Pursuant to these Acts, the

establishment of standards are not considered unnecessary obstacles to the foreign commerce of the United States, so long as the standards have a legitimate domestic objective, such as the protection of safety, and do not operate in a manner that excludes imports that meet this objective. The statute also requires consideration of international standards and, where appropriate, that they be the basis for U.S. standards. PHMSA notes the purpose is to ensure the safety of the American public, and has assessed the effects of this rule to ensure that it does not exclude imports that meet this objective. As a result, this final rule is not considered as creating an unnecessary obstacle to foreign commerce.

List of Subjects

49 CFR Part 105

Administrative practice and procedure, Hazardous materials transportation, Penalties, Reporting and recordkeeping requirements.

49 CFR Part 171

Exports, Hazardous materials transportation, Hazardous waste, Imports, Incorporation by reference, Reporting and recordkeeping requirements.

49 CFR Part 172

Education, Hazardous materials transportation, Hazardous waste, Incorporation by Reference, Labeling, Markings, Packaging and containers, Reporting and recordkeeping requirements.

49 CFR Part 173

Hazardous materials transportation, Incorporation by Reference, Packaging and containers, Radioactive materials, Reporting and recordkeeping requirements, Uranium.

49 CFR Part 177

Hazardous materials transportation, Loading and Unloading, Segregation and Separation.

49 CFR Part 178

Hazardous materials transportation, Incorporation by reference, Motor

vehicle safety, Packaging and containers, Reporting and recordkeeping requirements.

49 CFR Part 180

Hazardous materials transportation, Motor carriers, Motor vehicle safety, Packaging and containers, Railroad safety, Reporting and recordkeeping requirements.

In consideration of the foregoing, we are amending 49 CFR Chapter I as follows:

PART 105—HAZARDOUS MATERIALS PROGRAM PROCEDURES

- 1. The authority citation for part 105 continues to read as follows:

Authority: 49 U.S.C. 5101–5127; 49 CFR 1.53.

- 2. In § 105.40, paragraph (d) is revised to read as follows:

§ 105.40 Designated agents for non-residents.

* * * * *

(d) Each designation must be submitted to: Approvals and Permits Division, Pipeline and Hazardous Materials Safety Administration, Attn: PHH-30, U.S. Department of Transportation, East Building, 1200 New Jersey Avenue SE., Washington, DC 20590-0001 or by electronic mail to: specialpermits@dot.gov or approvals@dot.gov as appropriate.

* * * * *

PART 171—GENERAL INFORMATION, REGULATIONS, AND DEFINITIONS

- 3. The authority citation for part 171 continues to read as follows:

Authority: 49 U.S.C. 5101–5128, 44701; 49 CFR 1.45 and 1.53; Pub. L. 101-410 section 4 (28 U.S.C. 2461 note); Pub. L. 104-134, section 31001.

- 4. In § 171.7, in “Table 1 to 49 CFR 171.7—Materials Not Incorporated by Reference”, the following entry is added in alphabetical order to read as follows:

§ 171.7 Reference material.

* * * * *

Source and name of material	49 CFR reference
* * * * *	
<i>The Sulphur Institute</i> , 1020 19th St. NW., Suite 520, Washington, DC 20036.	
Molten Sulphur Rail Tank Car Guidance document, November 2010	172.102
* * * * *	

* * * * *

**PART 172—HAZARDOUS MATERIALS
TABLE, SPECIAL PROVISIONS,
HAZARDOUS MATERIALS
COMMUNICATIONS, EMERGENCY
RESPONSE INFORMATION, AND
TRAINING REQUIREMENTS**

■ 5. The authority citation for part 172 continues to read as follows:

Authority: 49 U.S.C. 5101–5128, 44701; 49 CFR 1.53.

■ 6. In § 172.101, the Hazardous Materials Table is amended by removing the entries under “[REMOVE]”, by adding the entries under “[ADD]” in alphabetical order, and revising entries under “[REVISE]” to read as follows:

§ 172.101 Purpose and use of hazardous materials table.

* * * * *

§ 172.101—HAZARDOUS MATERIALS TABLE

(1) Symbols	(2) Hazardous materials descriptions and proper shipping names	(3) Hazard class or division	(4) Identification Nos.	(5) PG	(6) Label codes	(7) Special provisions (§ 172.102)	(8) Packaging (§ 173.***)			(9) Quantity limitations		(10) Vessel stowage	
							Exceptions	Non-bulk	Bulk	Passenger aircraft/rail	Cargo aircraft only	Location	Other
(1)	(2)	(3)	(4)	(5)	(6)	(7)	(8A)	(8B)	(8C)	(9A)	(9B)	(10A)	(10B)
	[REMOVE].												
	Hydrazine dicarbonic acid diazide.	Forbidden.		*	*	*	*	*	*	*	*		
			II	8, 6.1	B16, B53, IB2, T7, TP2, TP13	None	202	243	Forbidden	30 L	D	40	II.
			III	8, 6.1	B16, B53, IB3, T4, TP1.	154	203	241	5 L	60 L	D	40	III.
	Zinc ethyl, see Diethylzinc.			*	*	*	*	*	*	*	*		
	[ADD].			*	*	*	*	*	*	*	*		
	Hydrazine dicarbonic acid diazide.	Forbidden.		*	*	*	*	*	*	*	*		
	Paint related material, flammable, corrosive (including paint thinning or reducing compound).	3	UN3469	II	3, 8	IB2, T7, TP2, TP8, TP28.	150	202	243	1 L	5 L	B	40.
				III	3, 8	IB3, T4, TP1, TP29.	150	203	242	5 L	60 L	A	40.
	[REVISE].			*	*	*	*	*	*	*	*		
	tert-Butyl isocyanate	6.1	UN2484	I	6.1, 3	1, B9, B14, B30, T20, TP2, TP13, TP38, TP44.	None	226	244	Forbidden	Forbidden	D	40.
D	Ethyl phosphonothioic dichloride, anhydrous.	6.1	NA2927	I	6.1, 8	2, B9, B14, B32, T20, TP4, TP12, TP13, TP38, TP45.	None	227	244	Forbidden	Forbidden	D	40.
D	Ethyl phosphorous dichloride, anhydrous pyrophoric liquid.	6.1	NA2845	I	6.1, 4.2	2, B9, B14, B32, T20, TP4, TP12, TP13, TP38, TP45.	None	227	244	Forbidden	Forbidden	D	18.
D	Ethyl phosphorodichloridate.	6.1	NA2927	I	6.1, 8	2, B9, B14, B32, T20, TP4, TP12, TP13, TP38, TP45.	None	227	244	Forbidden	Forbidden	D	40.

§ 172.101—HAZARDOUS MATERIALS TABLE—Continued

(1) Symbols	(2) Hazardous materials descriptions and proper shipping names	(3) Hazard class or division	(4) Identification Nos.	(5) PG	(6) Label codes	(7) Special provisions (§ 172.102)	(8) Packaging (§ 173.***)			(9) Quantity limitations		(10) Vessel stowage	
							Exceptions	Non-bulk	Bulk	Passenger aircraft/rail	Cargo aircraft only	Location	Other
D	Methyl phosphonous dichloride, <i>pyrophoric liquid</i> .	6.1	NA2845	I	6.1, 4.2	2, B9, B14, B16, B32, T20, TP4, TP12, TP13, TP38, TP45.	None	227 244	Forbidden	Forbidden		D 18.	
D	Sulfur, molten	9	NA2448	III	9	30, B13, IB3, R1, T1, TP3.	None	213 247	Forbidden	Forbidden		C 61.	
I	Sulfur, molten	4.1	UN2448	III	4.1	30, B13, IB1, R1, T1, TP3.	None	213 247	Forbidden	Forbidden		C 74.	
+	Sulfuric acid, fuming with 30 percent or more free sulfur trioxide.	8	UN1831	I	8, 6.1	2, B9, B14, B32, B77, B84, N34, T20, TP2, TP12, TP13.	None	227 244	Forbidden	Forbidden		C 14, 40.	
G	Toxic by inhalation liquid, flammable, corrosive, n.o.s. with an LC50 lower than or equal to 200 ml/m3 and saturated vapor concentration greater than or equal to 500 LC50.	6.1	UN3488	I	6.1, 3, 8	1, B9, B14, B30, T22, TP2, TP13, TP27, TP38, TP44.	None	226 244	Forbidden	Forbidden		D 40, 125.	
G	Toxic by inhalation liquid, flammable, corrosive, n.o.s. with an LC50 lower than or equal to 1000 ml/m3 and saturated vapor concentration greater than or equal to 10 LC50.	6.1	UN3489	I	6.1, 3, 8	2, B9, B14, B32, T20, TP2, TP13, TP27, TP38, TP45.	None	227 244	Forbidden	Forbidden		D 40, 125.	
G	Toxic by inhalation liquid, water-reactive, flammable, n.o.s. with an LC50 lower than or equal to 200 ml/m3 and saturated vapor concentration greater than or equal to 500 LC50.	6.1	UN3490	I	6.1, 4.3, 3	1, B9, B14, B30, T22, TP2, TP13, TP27, TP38, TP44.	None	226 244	Forbidden	Forbidden		D 21, 28, 40, 49.	

G Toxic by inhalation liquid, water-reactive, flammable, n.o.s. with an LC50 lower or equal to 1000 ml/m³ and saturated vapor concentration greater than or equal to 10 LC50.

6.1 UN3491 I 6.1, 4.3, 3 2, B9, B14, B32, T20, TP2, TP13, TP27, TP38, TP45.

None 227 244 Forbidden

Forbidden

D 21, 28, 40, 49.

* * * * *

* * * * *

■ 7. In § 172.102, special provision 138 is revised in paragraph (c)(1) and paragraph (c)(6) is revised to read as follows:

§ 172.102 Special provisions.

* * * * *

(c) * * *

(1) * * *

138 This entry applies to lead compounds which, when mixed in a ratio of 1:1,000 with 0.07 M (Molar concentration) hydrochloric acid and stirred for one hour at a temperature of 23°C ± 2°C, exhibit a solubility of more than 5%. Lead compounds which, when mixed in a ratio of 1:1,000 with 0.07 M (Molar concentration) hydrochloric acid and stirred for one hour at a temperature of 23°C ± 2°C, exhibit a solubility of 5% or less are not subject to the requirements of this subchapter unless they meet criteria as another hazard class or division. Lead compounds that have a solubility of 5% or less in accordance with this special provision are not subject to the requirements of this subchapter that pertain to Marine Pollutants.

* * * * *

(6) "R" codes. These provisions apply only to transportation by rail.

R1 A person who offers for transportation tank cars containing sulfur, molten or residue of sulfur, molten may reference the Sulfur Institute's, "Molten Sulphur Rail Tank Car Guidance document" (see § 171.7 of this subchapter) to identify tank cars that may pose a risk in transportation due to the accumulation of formed, solid sulfur on the outside of the tank.

* * * * *

■ 8. In § 172.203, paragraphs (e)(1) and (2) are revised to read as follows:

§ 172.203 Additional description requirements.

* * * * *

(e) * * *

(1) The description on the shipping paper for a packaging containing the residue of a hazardous material may include the words "RESIDUE: Last Contained * * *" immediately before or after the basic shipping description on the shipping paper.

(2) The description on the shipping paper for a tank car containing the

residue of a hazardous material must include the phrase, "RESIDUE: LAST CONTAINED * * *" immediately before or after the basic shipping description or immediately preceding the proper shipping name of the material on the shipping paper.

* * * * *

■ 9. In § 172.704, paragraph (d) introductory text is revised to read as follows:

§ 172.704 Training requirements.

* * * * *

(d) Recordkeeping. Each hazmat employer must create and retain a record of current training of each hazmat employee, inclusive of the preceding three years, in accordance with this section for as long as that employee is employed by that employer as a hazmat employee and for 90 days thereafter. A hazmat employer must make a hazmat employee's record of current training available upon request, at a reasonable time and location, to an authorized official of the Department of Transportation or of an entity explicitly granted authority to enforce the HMR. The record must include:

* * * * *

PART 173—SHIPPERS—GENERAL REQUIREMENTS FOR SHIPMENTS AND PACKAGINGS

■ 10. The authority citation for part 173 continues to read as follows:

Authority: 49 U.S.C. 5101–5128, 44701; 49 CFR 1.45 and 1.53.

■ 11. In § 173.6, paragraph (a)(2) is revised to read as follows:

§ 173.6 Materials of trade exceptions.

* * * * *

(a) * * *

(2) A Division 2.1 or 2.2 material in a cylinder with a gross weight not over 100 kg (220 pounds), in a Dewar flask meeting the requirements of § 173.320, or a permanently mounted tank manufactured to the ASME Code of not more than 70 gallon water capacity for a non-liquefied Division 2.2 material with no subsidiary hazard.

* * * * *

■ 12. In § 173.12, paragraph (b)(3) is revised to read as follows:

§ 173.12 Exceptions for shipment of waste materials.

* * * * *

(b) * * *

(3) Prohibited materials. The following waste materials may not be packaged or described under the provisions of this paragraph (b): a material poisonous-by-inhalation, a temperature controlled material unless it complies with § 173.21(f)(1), a Division 6.1, Packing Group I material, chloric acid, and oleum (fuming sulfuric acid).

* * * * *

■ 13. In § 173.33, paragraph (g) is revised to read as follows:

§ 173.33 Hazardous materials in cargo tank motor vehicles.

* * * * *

(g) Remote control of self-closing stop valves—MC 330, MC 331 and MC 338 cargo tanks. Each liquid or vapor discharge opening in an MC 330 or MC 331 cargo tank and each liquid filling and liquid discharge line in an MC 338 cargo tank must be provided with a remotely controlled internal self-closing stop valve except when an MC 330 or MC 331 cargo tank is marked and used exclusively to transport carbon dioxide; an MC 338 is used to transport argon, carbon dioxide, helium, krypton, neon, nitrogen, or xenon; or an MC 338 utilizes an external self-closing stop valve to comply with the requirements in § 178.338–11(b). However, if the cargo tank motor vehicle was certified before January 1, 1995, this requirement is applicable only when an MC 330 or MC 331 cargo tank is used to transport a flammable liquid, flammable gas, hydrogen chloride (refrigerated liquid), or anhydrous ammonia; or when an MC 338 cargo tank is used to transport flammable ladings.

* * * * *

■ 14. In § 173.62, in paragraph (c)(5), in the Table of Packing Methods, Packing Instruction 130 is revised to read as follows:

§ 173.62 Specific packaging requirements for explosives.

* * * * *

(c) * * *

(5) * * *

TABLE OF PACKING METHODS

Table with 4 columns: Packaging instruction, Inner packagings, Intermediate packagings, Outer packaging. Row 1: 130, Not necessary, Not necessary, Boxes.

TABLE OF PACKING METHODS—Continued

Packaging instruction	Inner packagings	Intermediate packagings	Outer packaging
<p>Particular Packaging Requirements:</p> <p>1. The following applies to UN 0006, 0009, 0010, 0015, 0016, 0018, 0019, 0034, 0035, 0038, 0039, 0048, 0056, 0137, 0138, 0168, 0169, 0171, 0181, 0182, 0183, 0186, 0221, 0238, 0243, 0244, 0245, 0246, 0254, 0280, 0281, 0286, 0287, 0297, 0299, 0300, 0301, 0303, 0321, 0328, 0329, 0344, 0345, 0346, 0347, 0362, 0363, 0370, 0412, 0424, 0425, 0434, 0435, 0436, 0437, 0438, 0451, 0459 and 0488.</p> <p>Large and robust explosives articles, normally intended for military use, without their means of initiation or with their means of initiation containing at least two effective protective features, may be carried unpackaged. When such articles have propelling charges or are self-propelled, their ignition systems must be protected against stimuli encountered during normal conditions of transport. A negative result in Test Series 4 on an unpackaged article indicates that the article can be considered for transport unpackaged. Such unpackaged articles may be fixed to cradles or contained in crates or other suitable handling devices.</p> <p>2. Subject to approval by the Associate Administrator, large explosive articles, as part of their operational safety and suitability tests, subjected to testing that meets the intentions of Test Series 4 of the UN Manual of Tests and Criteria with successful test results, may be offered for transportation in accordance with the requirements of this subchapter.</p>			<p>Steel (4A). Aluminum (4B). Wood natural, ordinary (4C1). Wood natural, sift-proof walls (4C2). Plywood (4D). Reconstituted wood (4F). Fiberboard (4G). Plastics, expanded (4H1). Plastics, solid (4H2).</p> <p>Drums. Steel, removable head (1A2). Aluminum, removable head (1B2). Plywood (1D). Fiber (1G). Plastics, removable head (1H2).</p> <p>Large Packagings. Steel (50A). Aluminum (50B). Metal other than steel or aluminum (50N). Rigid plastics (50H). Natural wood (50C). Plywood (50D). Reconstituted wood (50F). Rigid fiberboard (50G).</p>
*	*	*	*

■ 15. In § 173.134, paragraph (c)(2) is revised to read as follows:

§ 173.134 Class 6, Division 6.2—Definitions and exceptions.

- * * * * *
- (c) * * *
- (2) The following materials may be offered for transportation and transported as a regulated medical waste when packaged in a rigid non-bulk packaging conforming to the general packaging requirements of §§ 173.24 and 173.24a and packaging requirements specified in 29 CFR 1910.1030 and transported by a private or contract carrier in a vehicle used exclusively to transport regulated medical waste:
- (i) Waste stock or culture of a Category B infectious substance;
 - (ii) Plant and animal waste regulated by the Animal and Plant Health Inspection Service (APHIS);
 - (iii) Waste pharmaceutical materials;
 - (iv) Laboratory and recyclable wastes;
 - (v) Infectious substances that have been treated to eliminate or neutralize pathogens;
 - (vi) Forensic materials being transported for final destruction;

- (vii) Rejected or recalled health care products;
- (viii) Documents intended for destruction in accordance with the Health Insurance Portability and Accountability Act of 1996 (HIPAA) requirements;
- (ix) Medical or clinical equipment and laboratory products provided they are properly packaged and secured against exposure or contamination; or
- (x) Sharps in sharp containers provided the containers are securely closed to prevent leaks or punctures; do not exceed 18 gallons capacity; registered under the Medical Device Regulations of FDA; made of puncture resistant plastic that meets ASTM Standard F2132–01, Standard Specification for Puncture Resistance of Materials Used in Containers for Discarded Medical Needles and Other Sharps; and are securely fitted into wheeled racks that hold them in an upright position. The wheeled racks must contain full rows of sharps containers secured in place by a moveable bar; and must be securely held in place on the motor vehicle by straps or load bars during transportation. No shelf in any wheeled

rack may exceed the manufacturer's recommended load capacity.

* * * * *

■ 16. In § 173.150, paragraph (d) is revised to read as follows:

§ 173.150 Exceptions for Class 3 (flammable and combustible liquids).

- * * * * *
- (d) *Alcoholic beverages.* (1) An alcoholic beverage (wine and distilled spirits as defined in 27 CFR 4.10 and 5.11), when transported via motor vehicle, vessel, or rail, is not subject to the requirements of this subchapter if the alcoholic beverage:
- (i) Contains 24 percent or less alcohol by volume;
 - (ii) Is contained in an inner packaging of 5 L (1.3 gallons) or less; or
 - (iii) Is a Packing Group III alcoholic beverage contained in a packaging 250 liters (66 gallons) or less;
- (2) An alcoholic beverage (wine and distilled spirits as defined in 27 CFR 4.10 and 5.11), when transported via aircraft, is not subject to the requirements of this subchapter if the alcoholic beverage:
- (i) Contains 24 percent or less alcohol by volume;

(ii) For transportation aboard a passenger-carrying aircraft, contains more than 24% but less than 70% alcohol by volume when in unopened retail packagings not exceeding 5 liters (1.3 gallons) carried in carry-on or checked baggage, with a total net quantity per person of 5 liters (1.3 gallons) (See § 175.10(a)(4) of this subchapter); or

(iii) When carried as cargo, contains more than 24% but less than 70% alcohol by volume in an inner packaging not exceeding 5 L (1.3 gallons).

* * * * *

■ 17. In § 173.159a, paragraphs (c) introductory text and (c)(1) are revised to read as follows:

§ 173.159a Exceptions for non-spillable batteries.

* * * * *

(c) Non-spillable batteries are excepted from the packaging requirements of § 173.159 under the following conditions:

(1) Non-spillable batteries must be securely packed in strong outer packagings or secured to skids or pallets capable of withstanding the shocks normally incident to transportation. The batteries must meet the requirements of § 173.159(a), be loaded or braced so as

to prevent damage and short circuits in transit, and any other material loaded in the same vehicle must be blocked, braced, or otherwise secured to prevent contact with or damage to the batteries. A non-spillable battery which is an integral part of and necessary for the operation of mechanical or electronic equipment must be securely fastened in the battery holder on the equipment.

* * * * *

PART 177—CARRIAGE BY PUBLIC HIGHWAY

■ 18. The authority citation for part 177 continues to read as follows:

Authority: 49 U.S.C. 5101–5127; 49 CFR 1.53.

■ 19. In § 177.834, paragraph (j)(2) is revised to read as follows:

§ 177.834 General requirements.

* * * * *

(j) * * *

(2) All valves and other closures in liquid discharge systems are closed and free of leaks, except external emergency self-closing valves on MC 338 cargo tanks containing the residue of cryogenic liquids may remain either open or closed during transit.

* * * * *

PART 178—SPECIFICATIONS FOR PACKAGINGS

■ 20. The authority citation for part 178 continues to read as follows:

Authority: 49 U.S.C. 5101–5128; 49 CFR 1.53.

■ 21. In § 178.2, paragraph (c)(1) introductory text is revised to read as follows:

§ 178.2 Applicability and responsibility.

* * * * *

(c) *Notification.* (1) Except as specifically provided in §§ 178.337–18, 178.338–19, and 178.345–15 of this part, the manufacturer or other person certifying compliance with the requirements of this part, and each subsequent distributor of that packaging must:

* * * * *

■ 22. In Appendix E to Part 178, Figure 1 and Figure 2 are added following the text to read as follows:

Appendix E to Part 178—Flame Penetration Resistance Test

* * * * *

Figure 1: Test Apparatus for Horizontal and Vertical Mounting

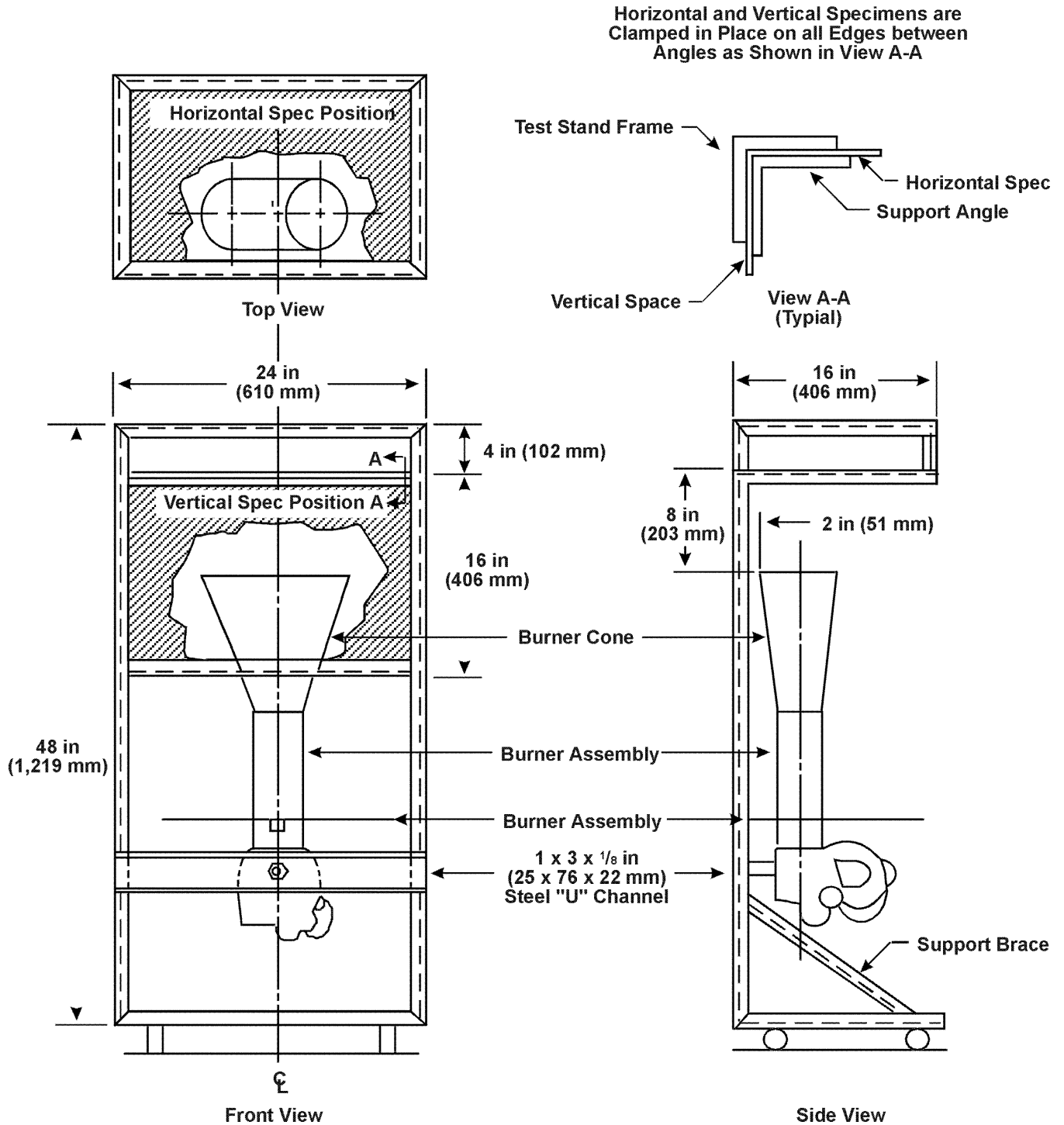
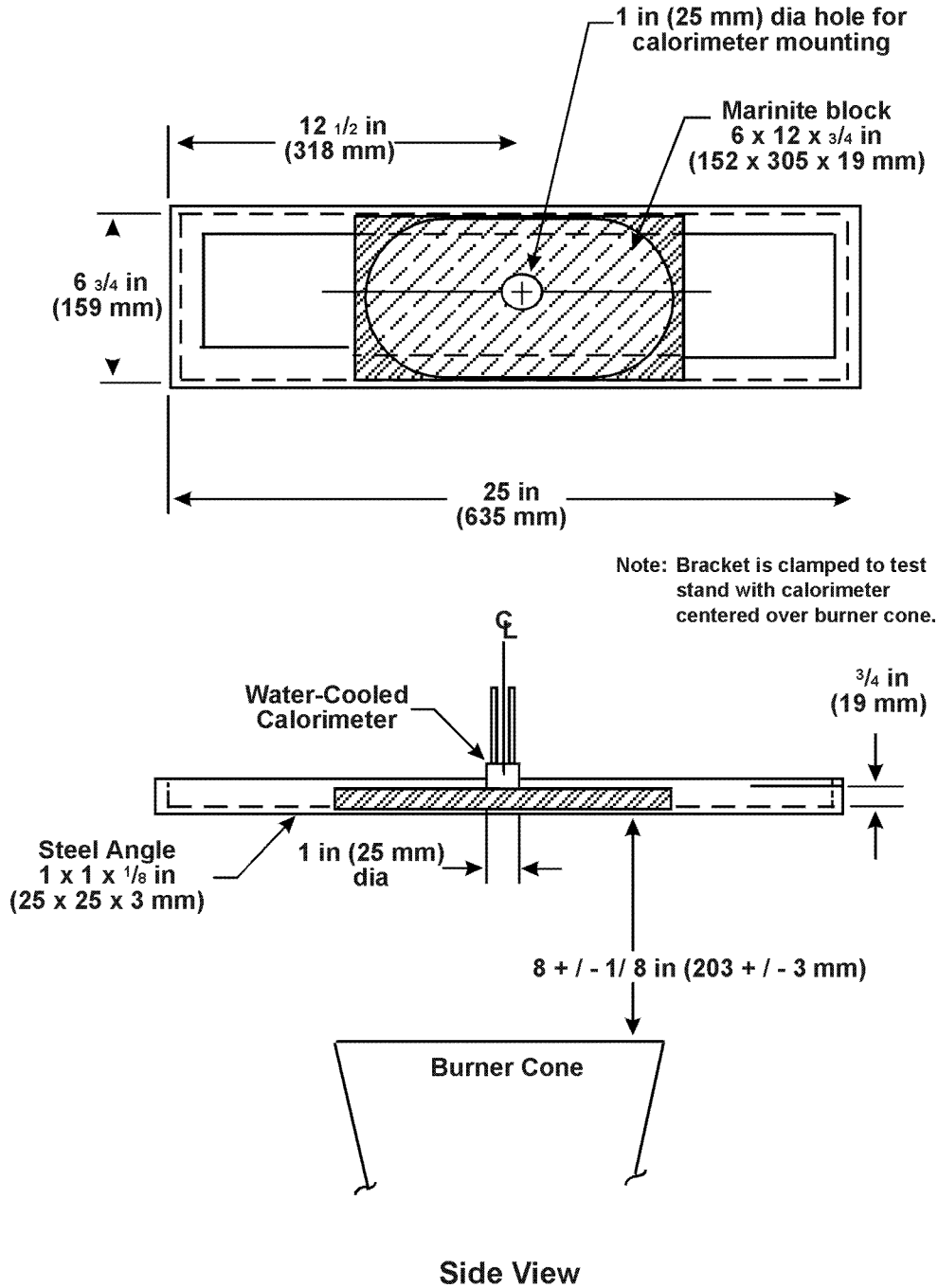

Figure 2: Calorimeter Bracket



PART 180—CONTINUING QUALIFICATION AND MAINTENANCE OF PACKAGINGS

■ 23. The authority citation for part 180 continues to read as follows:

Authority: 49 U.S.C. 5101–5128; 49 CFR 1.53.

■ 24. In § 180.416, paragraph (d)(5) is revised to read as follows:

§ 180.416 Discharge system inspection and maintenance program for cargo tanks transporting liquefied compressed gases.

* * * * *

(d) * * *

(5) The operator must note each inspection in a record. That record must include the inspection date, the name of the person performing the inspection, the hose assembly identification number, the manufacturer of the hose assembly, the date the hose was assembled and tested, and an indication

that the delivery hose assembly and piping system passed or failed the tests and inspections. The operator must retain a copy of each test and inspection record at its principal place of business or where the vehicle is housed or maintained until the next test of the same type is successfully completed.

* * * * *

Issued in Washington, DC on February 19, 2013, under authority delegated in 49 CFR part 106.

Cynthia L. Quarterman,

Administrator, Pipeline and Hazardous Materials Safety Administration.

[FR Doc. 2013-04198 Filed 3-8-13; 8:45 am]

BILLING CODE 4910-60-P