

DEPARTMENT OF TRANSPORTATION**Federal Aviation Administration****14 CFR Part 39**

[Docket No. FAA-2012-0773; Directorate Identifier 2009-SW-71-AD]

RIN 2120-AA64

Airworthiness Directives; Eurocopter Deutschland GmbH Helicopters**AGENCY:** Federal Aviation Administration, DOT.**ACTION:** Notice of proposed rulemaking (NPRM).

SUMMARY: We propose to adopt a new airworthiness directive (AD) for the Eurocopter Deutschland GmbH (Eurocopter) Model MBB-BK 117 C-2 helicopters. This proposed AD is prompted by the discovery that some helicopters have blind rivets installed in the place of solid rivets in the long tail rotor drive shaft. The proposed actions are intended to detect blind rivets installed in the long tail rotor drive shaft, which could lead to failure of the tail rotor drive shaft and subsequent loss of control of the helicopter.

DATES: We must receive comments on this proposed AD by September 24, 2012.

ADDRESSES: You may send comments by any of the following methods:

- *Federal eRulemaking Docket:* Go to <http://www.regulations.gov>. Follow the online instructions for sending your comments electronically.

- *Fax:* 202-493-2251.

- *Mail:* Send comments to the U.S. Department of Transportation, Docket Operations, M-30, West Building Ground Floor, Room W12-140, 1200 New Jersey Avenue SE., Washington, DC 20590-0001.

- *Hand Delivery:* Deliver to the "Mail" address between 9 a.m. and 5 p.m., Monday through Friday, except Federal holidays.

Examining the AD Docket

You may examine the AD docket on the Internet at <http://www.regulations.gov> or in person at the Docket Operations Office between 9 a.m. and 5 p.m., Monday through Friday, except Federal holidays. The AD docket contains this proposed AD, the economic evaluation, any comments received, and other information. The street address for the Docket Operations Office (telephone 800-647-5527) is in the **ADDRESSES** section. Comments will be available in the AD docket shortly after receipt.

For service information identified in this proposed AD, contact American

Eurocopter Corporation, 2701 N. Forum Drive, Grand Prairie, TX 75052, telephone (972) 641-0000 or (800) 232-0323, fax (972) 641-3775, or at <http://www.eurocopter.com/techpub>. You may review the referenced service information at the FAA, Office of the Regional Counsel, Southwest Region, 2601 Meacham Blvd., Room 663, Fort Worth, Texas 76137.

FOR FURTHER INFORMATION CONTACT: Jim Grigg, ASW-112, Manager, FAA, Rotorcraft Directorate, Safety Management Group, 2601 Meacham Blvd., Fort Worth, Texas 76137, telephone (817) 222-5126, fax (817) 222-5961, email jim.grigg@faa.gov.

SUPPLEMENTARY INFORMATION:**Comments Invited**

We invite you to participate in this rulemaking by submitting written comments, data, or views. We also invite comments relating to the economic, environmental, energy, or federalism impacts that might result from adopting the proposals in this document. The most helpful comments reference a specific portion of the proposal, explain the reason for any recommended change, and include supporting data. To ensure the docket does not contain duplicate comments, commenters should send only one copy of written comments, or if comments are filed electronically, commenters should submit only one time.

We will file in the docket all comments that we receive, as well as a report summarizing each substantive public contact with FAA personnel concerning this proposed rulemaking. Before acting on this proposal, we will consider all comments we receive on or before the closing date for comments. We will consider comments filed after the comment period has closed if it is possible to do so without incurring expense or delay. We may change this proposal in light of the comments we receive.

Discussion

The European Aviation Safety Agency (EASA), which is the Technical Agent for the Member States of the European Union, has issued EASA AD No. 2009-0119, dated June 4, 2009, to correct an unsafe condition for the Eurocopter Model MBB-BK 117 C-2 helicopters. EASA advises that an error was discovered in the Eurocopter aircraft maintenance manual (AMM), which erroneously specifies replacing the solid rivets on the long tail rotor drive shaft with blind rivets. All delivered helicopters had the long tail rotor drive shafts installed during production fitted

with the correct solid rivets. The long tail rotor drive shafts repaired in-service in accordance with the AMM may have blind rivets installed. This condition, if not corrected, could lead to a significant reduction of the life of the long tail rotor drive shaft, failure of the long tail rotor drive shaft, and subsequent loss of control of the helicopter.

FAA's Determination

These helicopters have been approved by the aviation authority of the Federal Republic of Germany and are approved for operation in the United States. Pursuant to our bilateral agreement with Germany, EASA, its technical representative, has notified us of the unsafe condition described in its AD. We are proposing this AD because we evaluated all known relevant information and determined that an unsafe condition exists and is likely to exist or develop on other helicopters of these same type designs.

Related Service Information

Eurocopter has issued Alert Service Bulletin No. MBB BK117 C-2-65A-003, dated May 4, 2009 (ASB), which specifies inspecting long tail rotor drive shafts to determine what type of rivets are installed. If one or more blind rivets are installed, the ASB specifies replacing the long tail rotor drive shaft assembly with a serviceable long tail rotor drive shaft assembly. EASA classified this ASB as mandatory and issued EASA AD No. 2009-0119, dated June 4, 2009, to ensure the continued airworthiness of these helicopters.

Proposed AD Requirements

This proposed AD would require, within 100 hours time-in-service (TIS), inspecting the long tail rotor drive shaft assembly for blind rivets. If there are no blind rivets installed on the shaft assembly, no further action would be required by this AD. If there are one or more blind rivets installed on the shaft assembly, this AD would require replacing the shaft assembly of the long tail rotor drive shaft with an airworthy shaft assembly before further flight.

Differences Between This Proposed AD and the EASA AD

This proposed AD uses the term "TIS" instead of "flight hours."

Costs of Compliance

We estimate that this proposed AD would affect 88 helicopters of U.S. registry. We estimate that operators may incur the following costs in order to comply with this AD:

- It would take about 2 work hours to inspect and replace the tail rotor at an average labor rate of \$85 per work hour.
- Required parts to replace each long tail rotor drive shaft assembly cost about \$4,600 each.

Based upon these figures, the total cost per helicopter would be \$4,770. The total cost for the entire U.S. fleet would be \$419,760, assuming that the long tail rotor drive shaft assembly would be required to be replaced on the entire fleet.

Authority for This Rulemaking

Title 49 of the United States Code specifies the FAA's authority to issue rules on aviation safety. Subtitle I, section 106, describes the authority of the FAA Administrator. "Subtitle VII: Aviation Programs," describes in more detail the scope of the Agency's authority.

We are issuing this rulemaking under the authority described in "Subtitle VII, Part A, Subpart III, Section 44701: General requirements." Under that section, Congress charges the FAA with promoting safe flight of civil aircraft in air commerce by prescribing regulations for practices, methods, and procedures the Administrator finds necessary for safety in air commerce. This regulation is within the scope of that authority because it addresses an unsafe condition that is likely to exist or develop on products identified in this rulemaking action.

Regulatory Findings

We determined that this proposed AD would not have federalism implications under Executive Order 13132. This proposed AD would not have a

substantial direct effect on the States, on the relationship between the national Government and the States, or on the distribution of power and responsibilities among the various levels of government.

For the reasons discussed, I certify this proposed regulation:

1. Is not a "significant regulatory action" under Executive Order 12866;
2. Is not a "significant rule" under the DOT Regulatory Policies and Procedures (44 FR 11034, February 26, 1979);
3. Will not affect intrastate aviation in Alaska to the extent that it justifies making a regulatory distinction; and
4. Will not have a significant economic impact, positive or negative, on a substantial number of small entities under the criteria of the Regulatory Flexibility Act.

We prepared an economic evaluation of the estimated costs to comply with this proposed AD and placed it in the AD docket.

List of Subjects in 14 CFR Part 39

Air transportation, Aircraft, Aviation safety, Incorporation by reference, Safety.

The Proposed Amendment

Accordingly, under the authority delegated to me by the Administrator, the FAA proposes to amend 14 CFR part 39 as follows:

PART 39—AIRWORTHINESS DIRECTIVES

1. The authority citation for part 39 continues to read as follows:

Authority: 49 U.S.C. 106(g), 40113, 44701.

§ 39.13 [Amended]

2. The FAA amends § 39.13 by adding the following new airworthiness directive (AD):

Eurocopter Deutschland GmbH: Docket No. FAA-2012-0773; Directorate Identifier 2009-SW-71-AD.

(a) Applicability

This AD applies to Model MBB BK117 C-2 helicopters, with long tail rotor drive shaft assembly part number (P/N) B651M1002101 or B651M1002102 installed, certificated in any category.

(b) Unsafe Condition

This AD defines the unsafe condition as the installation of blind rivets instead of solid rivets in the long tail rotor drive shaft. This condition could result in failure of the long tail rotor drive shaft and subsequent loss of control of the helicopter.

(c) Compliance

You are responsible for performing each action required by this AD within the specified compliance time unless it has already been accomplished prior to that time.

(d) Actions Required

Within 100 hours time-in-service (TIS), inspect the long tail rotor drive shaft assembly for blind rivets as indicated in sections A-A and B-B of Figure 1 to Paragraph (d) of this AD.

(1) If there are no blind rivets installed on the shaft assembly, no further action is required by this AD.

(2) If there are one or more blind rivets installed on the shaft assembly in the areas depicted in Figure 1 to Paragraph (d) of this AD, before further flight, replace the shaft assembly of the long tail rotor drive shaft with an airworthy shaft assembly that does not have blind rivets installed.

(3) After the effective date of this AD, do not install a tail rotor drive shaft assembly that has blind rivets installed.

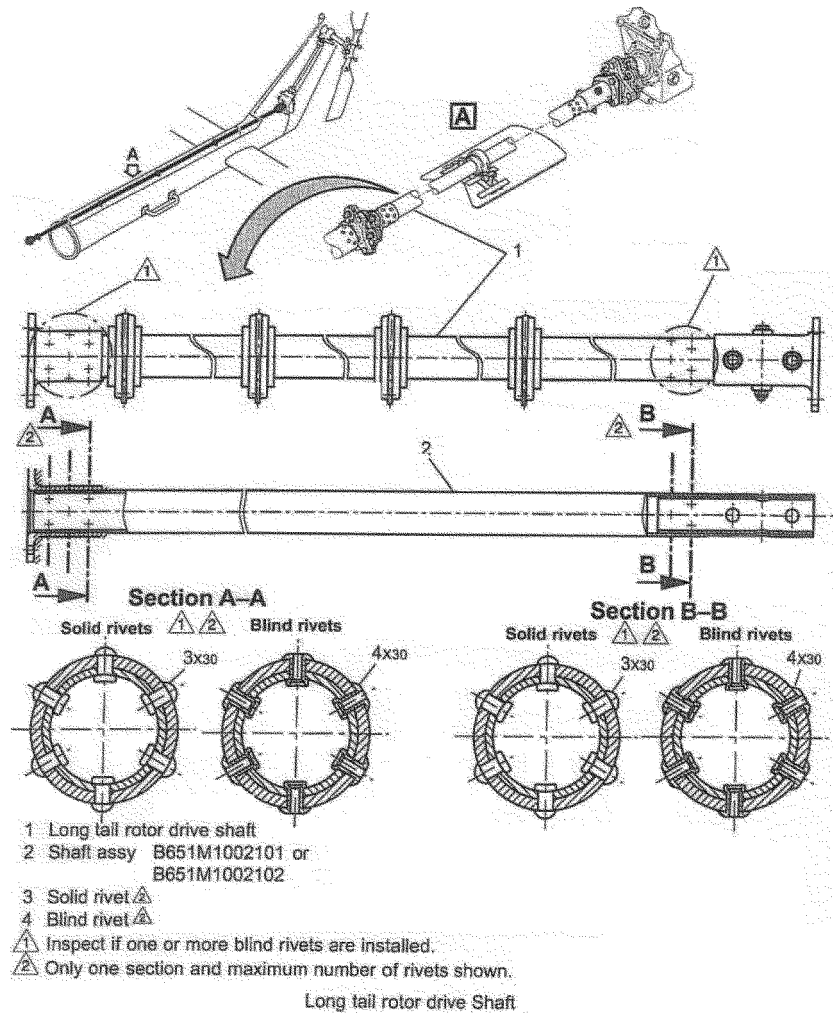

Figure 1 to Paragraph (d)

(e) Alternative Methods of Compliance (AMOC)

(1) The Manager, FAA, Safety Management Group, may approve AMOCs for this AD. Send your proposal to: Jim Grigg, ASW-112, Manager, Rotorcraft Directorate, Safety Management Group, 2601 Meacham Blvd., Fort Worth, Texas 76137, telephone (817) 222-5126, fax (817) 222-5961, email jim.grigg@faa.gov.

(2) For operations conducted under 14 CFR part 119 operating certificate or under 14 CFR part 91, subpart K, we suggest that you notify your principal inspector, or lacking a principal inspector, the manager of the local flight standards district office or certificate holding district office before operating any aircraft complying with this AD through an AMOC.

(f) Additional Information

(1) Eurocopter Alert Service Bulletin No. MBB BK117 C-2-65A-003, dated May 4, 2009, which is not incorporated by reference, contains additional information about the subject of this AD. For service information identified in this AD, contact American

Eurocopter Corporation, 2701 N. Forum Drive, Grand Prairie, TX 75052, telephone (972) 641-0000 or (800) 232-0323, fax (972) 641-3775, or at <http://www.eurocopter.com/techpub>. You may review the referenced service information at the FAA, Office of the Regional Counsel, Southwest Region, 2601 Meacham Blvd., Room 663, Fort Worth, Texas 76137.

(2) The subject of this AD is addressed in European Aviation Safety Agency AD No. 2009-0119, dated June 4, 2009.

(g) Subject

Joint Aircraft System/Component (JASC) Code 6510: Tail Rotor Drive Shaft.

Issued in Fort Worth, Texas, on July 18, 2012.

Kim Smith,

Manager, Rotorcraft Directorate, Aircraft Certification Service.

[FR Doc. 2012-18254 Filed 7-25-12; 8:45 am]

BILLING CODE 4910-13-P

DEPARTMENT OF TRANSPORTATION

Federal Aviation Administration

14 CFR Part 39

[Docket No. FAA-2012-0772; Directorate Identifier 2007-SW-053-AD]

RIN 2120-AA64

Airworthiness Directives; Eurocopter France Helicopters

AGENCY: Federal Aviation Administration (FAA), DOT.

ACTION: Notice of proposed rulemaking (NPRM).

SUMMARY: We propose to adopt a new airworthiness directive (AD) for Eurocopter France (Eurocopter) Model EC130 B4 helicopters with a cabin vibration damper installed. This proposed AD is prompted by a crack and failure of a cabin vibration damper