

Figure 1

(2) If there is a crack or if a pilot indicates that the center windscreen distorted during flight, before further flight, replace the center windscreen with an airworthy center windscreen, P/N 350A25-9045-20, in accordance with the Accomplishment Instructions, paragraphs 2.B.2.b. through 2.B.2.b.4. of Eurocopter Service Bulletin No. 56-003, Revision 0, dated November 16, 2010.

(3) Within 12 months, replace the center windscreen with an airworthy center windscreen, P/N 350A25-9045-20, in accordance with the instructions contained in paragraph (d)(2) of this AD.

(4) Replacing the center windscreen with center windscreen, P/N 350A25-9045-20, constitutes terminating action for the requirements of this AD.

(e) Special Flight Permit

Special flight permits may be issued in accordance with 14 CFR §§ 21.197 and 21.199 to operate the helicopter to a location where the requirements of this AD can be accomplished, provided that:

- (1) No passengers are onboard;
- (2) The time to fly to the location does not exceed 10 hours time-in-service; and
- (3) The airspeed does not exceed 70 knots indicated air speed (KIAS).

(f) Alternative Methods of Compliance (AMOC)

(1) The Manager, Safety Management Group, FAA, may approve AMOCs for this AD. Send your proposal to: Jim Grigg, Manager, Safety Management Group, Rotorcraft Directorate, FAA, 2601 Meacham Blvd., Fort Worth, TX 76137; telephone (817) 222-5110; email jim.grigg@faa.gov.

(2) For operations conducted under a 14 CFR part 119 operating certificate or under 14 CFR part 91, subpart K, we suggest that you notify your principal inspector, or lacking a principal inspector, the manager of the local flight standards district office or certificate holding district office before operating any aircraft complying with this AD through an AMOC.

(g) Additional Information

(1) For service information identified in this AD, contact American Eurocopter Corporation, 2701 N. Forum Drive, Grand Prairie, TX 75052, telephone (972) 641-0000 or (800) 232-0323, fax (972) 641-3775, or at <http://www.eurocopter.com/techpub>. You may review a copy of the service information at the FAA, Office of the Regional Counsel, Southwest Region, 2601 Meacham Blvd., Room 663, Fort Worth, Texas 76137.

(2) The subject of this AD is addressed in the European Aviation Safety Agency (EASA) AD No. 2010-0258, dated December 6, 2010.

(h) Subject

Joint Aircraft Service Component (JASC) Code: 5600, Window/Windshield System.

Issued in Fort Worth, Texas, on June 8, 2012.

Kim Smith,

Manager, Rotorcraft Directorate, Aircraft Certification Service.

[FR Doc. 2012-14799 Filed 6-15-12; 8:45 am]

BILLING CODE 4910-13-P

DEPARTMENT OF TRANSPORTATION

Federal Aviation Administration

14 CFR Part 39

[Docket No. FAA-2012-0631; Directorate Identifier 2011-SW-021-AD]

RIN 2120-AA64

Airworthiness Directives; Eurocopter France Helicopters

AGENCY: Federal Aviation Administration (FAA), DOT.

ACTION: Notice of proposed rulemaking (NPRM).

SUMMARY: We propose to adopt a new airworthiness directive (AD) for Eurocopter France Model AS350B, AS350BA, AS350B1, AS350B2, AS350B3, AS350C, AS350D, AS350D1, AS355E, AS355F, AS355F1, AS355F2, AS355N, and AS355NP helicopters with certain Aerazur emergency flotation gear attachment brackets (brackets) installed. This proposed AD would require an initial and recurring inspection of the brackets for a crack, and if there is a crack, replacing the cracked bracket with an airworthy bracket. This proposed AD is prompted by reports of cracks on the brackets. The proposed actions are intended to prevent failure of the emergency flotation system and loss of float stability in the event of a water landing.

DATES: We must receive comments on this proposed AD by August 17, 2012.

ADDRESSES: You may send comments by any of the following methods:

- *Federal eRulemaking Docket:* Go to <http://www.regulations.gov>. Follow the online instructions for sending your comments electronically.

- *Fax:* 202-493-2251.

- *Mail:* Send comments to the U.S. Department of Transportation, Docket Operations, M-30, West Building Ground Floor, Room W12-140, 1200 New Jersey Avenue SE., Washington, DC 20590-0001.

- *Hand Delivery:* Deliver to the "Mail" address between 9 a.m. and 5 p.m., Monday through Friday, except Federal holidays.

Examining the AD Docket: You may examine the AD docket on the Internet at <http://www.regulations.gov> or in person at the Docket Operations Office between 9 a.m. and 5 p.m., Monday through Friday, except Federal holidays. The AD docket contains this proposed AD, the economic evaluation, any comments received, and other information. The street address for the Docket Operations Office (telephone 800-647-5527) is in the **ADDRESSES** section. Comments will be available in the AD docket shortly after receipt.

For service information identified in this proposed AD, contact American Eurocopter Corporation, 2701 N. Forum Drive, Grand Prairie, Texas 75052; telephone (972) 641-0000 or (800) 232-0323; fax (972) 641-3775; or at <http://www.eurocopter.com/techpub>. You may review the referenced service information at the FAA, Office of the Regional Counsel, Southwest Region, 2601 Meacham Blvd., Room 663, Fort Worth, Texas 76137.

FOR FURTHER INFORMATION CONTACT: Jim Grigg, Manager, Safety Management Group, Rotorcraft Directorate, FAA, 2601 Meacham Blvd., Fort Worth, Texas 76137; telephone (817) 222-5110; email jim.grigg@faa.gov.

SUPPLEMENTARY INFORMATION:

Comments Invited

We invite you to participate in this rulemaking by submitting written comments, data, or views. We also invite comments relating to the economic, environmental, energy, or federalism impacts that might result from adopting the proposals in this document. The most helpful comments reference a specific portion of the proposal, explain the reason for any recommended change, and include supporting data. To ensure the docket does not contain duplicate comments, commenters should send only one copy of written comments, or if comments are filed electronically, commenters should submit only one time.

We will file in the docket all comments that we receive, as well as a report summarizing each substantive public contact with FAA personnel concerning this proposed rulemaking. Before acting on this proposal, we will consider all comments we receive on or before the closing date for comments. We will consider comments filed after the comment period has closed if it is possible to do so without incurring expense or delay. We may change this proposal in light of the comments we receive.

Discussion

The European Aviation Safety Agency (EASA), which is the Technical Agent for the Member States of the European Union, issued AD No. 2011-0072, dated April 20, 2011 (AD 2011-0072), to correct an unsafe condition for the Eurocopter AS350B, AS350BA, AS350BB, AS350B1, AS350B2, AS350B3, AS350D, AS355E, AS355F, AS355F1, AS355F2, AS355N, and AS355NP helicopters with Aerazur emergency flotation gear attachments installed. EASA advises of several reports of cracks being found on the brackets which appear to be caused by stress corrosion. This condition, if not corrected, could result in "rupture of the emergency flotation gear attachment brackets" during a water landing, no longer ensuring float stability of the helicopter, possibly resulting in damage to the helicopter and injury to the occupants. The EASA's AD requires an initial inspection of the brackets, replacement of any brackets found with cracks, and re-inspection of the brackets every 13 months.

FAA's Determination

These helicopters have been approved by the aviation authority of France and are approved for operation in the United States. Pursuant to our bilateral agreement with France, the EASA, its technical representative, has notified us of the unsafe condition described in its AD. We are proposing this AD because we evaluated all known relevant information and determined that an unsafe condition is likely to exist or develop on other helicopters of these same type designs.

Related Service Information

Eurocopter issued Alert Service Bulletin (ASB) No. AS350-05.00.63, Revision 1, dated April 18, 2011 (AS350-05.00.63), and ASB No. AS355-05.00.58, Revision 1, dated April 18, 2011 (AS355-05.00.58). These ASBs specify procedures to inspect the front and rear brackets at regular intervals. The EASA classified these ASBs as mandatory and issued EASA AD 2011-0072 to ensure the continued airworthiness of these helicopters.

Proposed AD Requirements

This proposed AD would require inspecting the brackets for a crack within 110 hours time-in-service (TIS) or 3 months, whichever occurs first and, if there is a crack, replacing the cracked bracket with an airworthy bracket. This proposed AD would also require repeating the inspection at intervals not to exceed 13 months.

Differences Between This Proposed AD and the EASA AD

Differences between this proposed AD and the EASA AD include:

- The EASA AD applies to Eurocopter Model AS 350 BB helicopters; this proposed AD does not as this model is not type certificated by the FAA. Additionally, the EASA AD excludes Eurocopter Models AS350C and AS350D1, whereas this proposed AD includes them.

- The EASA AD mandates different compliance times depending on the manufacture date of the helicopter; we mandate inspecting all helicopters within 110 hours TIS or 3 months, whichever occurs first, regardless of date of manufacture.

- This proposed AD does not require returning cracked brackets to the manufacturer.

Interim Action

We consider this proposed AD interim action. Eurocopter is currently developing a modification that will address the unsafe condition identified in this AD. Once this modification is

developed, approved, and available, we might consider additional rulemaking.

Costs of Compliance

We estimate that this proposed AD would affect 733 helicopters of U.S. Registry. We estimate that operators may incur the following costs in order to comply with this AD. It would take about 4 work-hours per inspection cycle and the average labor rate is \$85 per work-hour. Based on these estimates, the total cost per inspection cycle would be \$340 per helicopter and \$249,220 on the U.S. fleet. Required parts for one bracket replacement would cost about \$1,130 and replacement would take about 1 work-hour. Thus, the total cost to replace one bracket would be about \$1,215; however, we have no way of determining the number of helicopters that might need these replacements.

Authority for This Rulemaking

Title 49 of the United States Code specifies the FAA's authority to issue rules on aviation safety. Subtitle I, section 106, describes the authority of the FAA Administrator. "Subtitle VII: Aviation Programs," describes in more detail the scope of the Agency's authority.

We are issuing this rulemaking under the authority described in "Subtitle VII, Part A, Subpart III, Section 44701: General requirements." Under that section, Congress charges the FAA with promoting safe flight of civil aircraft in air commerce by prescribing regulations for practices, methods, and procedures the Administrator finds necessary for safety in air commerce. This regulation is within the scope of that authority because it addresses an unsafe condition that is likely to exist or develop on products identified in this rulemaking action.

Regulatory Findings

We determined that this proposed AD would not have federalism implications under Executive Order 13132. This proposed AD would not have a substantial direct effect on the States, on the relationship between the national Government and the States, or on the distribution of power and responsibilities among the various levels of government.

For the reasons discussed, I certify this proposed regulation:

1. Is not a "significant regulatory action" under Executive Order 12866;
2. Is not a "significant rule" under the DOT Regulatory Policies and Procedures (44 FR 11034, February 26, 1979);
3. Will not affect intrastate aviation in Alaska to the extent that it justifies making a regulatory distinction; and
4. Will not have a significant economic impact, positive or negative, on a substantial number of small entities under the criteria of the Regulatory Flexibility Act.

We prepared an economic evaluation of the estimated costs to comply with this proposed AD and placed it in the AD docket.

List of Subjects in 14 CFR Part 39

Air transportation, Aircraft, Aviation safety, Incorporation by reference, Safety.

The Proposed Amendment

Accordingly, under the authority delegated to me by the Administrator, the FAA proposes to amend 14 CFR part 39 as follows:

PART 39—AIRWORTHINESS DIRECTIVES

1. The authority citation for part 39 continues to read as follows:

Authority: 49 U.S.C. 106(g), 40113, 44701.

§ 39.13 [Amended]

2. The FAA amends § 39.13 by adding the following new airworthiness directive (AD):

Eurocopter France: Docket No. FAA-2012-0631; Directorate Identifier 2011-SW-021-AD.

(a) Applicability

This AD applies to Eurocopter France Model AS350B, AS350BA, AS350B1, AS350B2, AS350B3, AS350C, AS350D, AS350D1, AS355E, AS355F, AS355F1, AS355F2, AS355N, and AS355NP helicopters with an Aerazur emergency flotation gear attachment bracket, part number 158172, 158173, 158288, or 158289, installed, certificated in any category.

(b) Unsafe Condition

This AD defines the unsafe condition as a crack in an attachment bracket of the emergency flotation gear. This condition could result in failure of the emergency flotation system and loss of float stability in the event of a water landing.

(c) Compliance

You are responsible for performing each action required by this AD within the specified compliance time unless it has already been accomplished prior to that time.

(d) Required Actions

Within 110 hours time-in-service or 3 months, whichever occurs first, and thereafter at intervals not to exceed 13 months:

- (1) Using a 5x or higher power magnifying glass, visually inspect the front emergency flotation gear attachment bracket (Figure 1 of this AD, section B-B, item (e)) in Areas F, G, and H; and the rear emergency flotation gear attachment bracket (Figure 1 of this AD, section A-A, item (a)) in Areas D and E for a crack.

BILLING CODE 4910-13-P

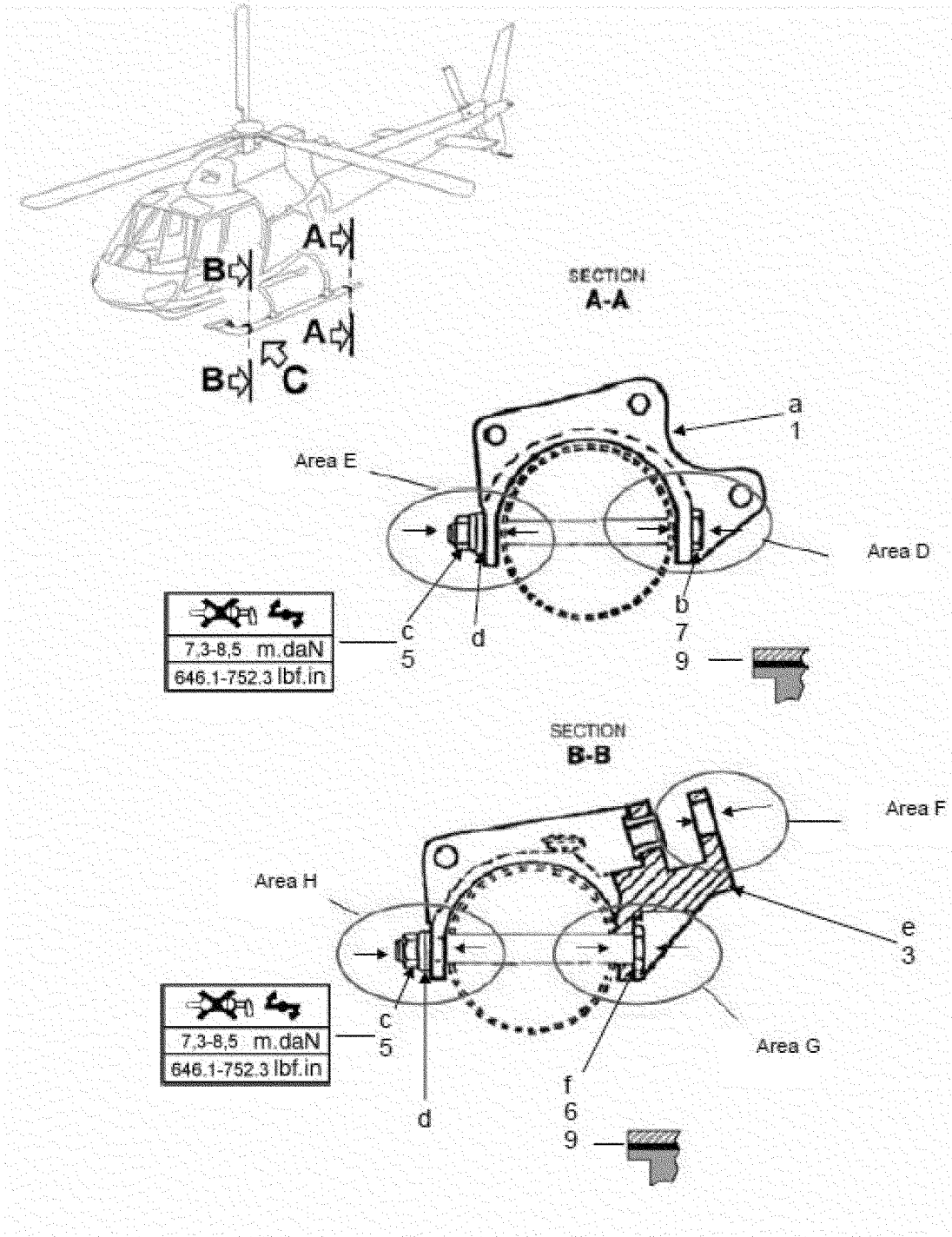

Figure 1. Emergency Flotation Gear Attachment Brackets

BILLING CODE 4910-13-C

(2) If there is a crack, replace the cracked emergency flotation gear attachment bracket with an airworthy emergency flotation gear attachment bracket prior to reinstallation of the emergency flotation equipment.

(e) Alternative Methods of Compliance (AMOC)

(1) The Manager, Rotorcraft Directorate, FAA, may approve AMOCs for this AD. Send your proposal to: Jim Grigg, Manager, Safety Management Group, Rotorcraft Directorate, FAA, 2601 Meacham Blvd., Fort Worth, Texas 76137; telephone (817) 222-5110; email jim.grigg@faa.gov.

(2) For operations conducted under a 14 CFR part 119 operating certificate or under 14 CFR part 91, subpart K, we suggest that you notify your principal inspector, or lacking a principal inspector, the manager of the local flight standards district office or certificate holding district office before operating any aircraft complying with this AD through an AMOC.

(f) Additional Information

(1) Eurocopter Alert Service Bulletin (ASB) No. AS350-05.00.63, Revision 1, dated April 18, 2011, and ASB No. AS355-05.00.58, Revision 1, dated April 18, 2011, which are not incorporated by reference, contain additional information about the subject of this AD. For this service information, contact American Eurocopter Corporation, 2701 N. Forum Drive, Grand Prairie, Texas 75052; telephone (972) 641-0000 or (800) 232-0323; fax (972) 641-3775; or at <http://www.eurocopter.com/techpub>. You may review this service information at the FAA, Office of the Regional Counsel, Southwest Region, 2601 Meacham Blvd., Room 663, Fort Worth, Texas 76137.

(2) The subject of this AD is addressed in European Aviation Safety Agency (EASA) AD No. 2011-0072, dated April 20, 2011.

(g) Subject

Joint Aircraft Service Component (JASC) Code: 2560, Emergency Equipment.

Issued in Fort Worth, Texas, on June 8, 2012.

Kim Smith,

Manager, Rotorcraft Directorate, Aircraft Certification Service.

[FR Doc. 2012-14807 Filed 6-15-12; 8:45 am]

BILLING CODE 4910-13-P

DEPARTMENT OF TRANSPORTATION**Federal Aviation Administration****14 CFR Part 39**

[Docket No. FAA-2012-0632; Directorate Identifier 2011-SW-044-AD]

RIN 2120-AA64

Airworthiness Directives; Eurocopter France Helicopters

AGENCY: Federal Aviation Administration (FAA), DOT.

ACTION: Notice of proposed rulemaking (NPRM).

SUMMARY: We propose to adopt a new airworthiness directive (AD) for all Eurocopter France (Eurocopter) Model SA-365N, SA-365N1, AS-365N2, AS 365 N3, EC 155B, EC155B1, SA-365C, SA-365C1, SA-365C2, and SA-366G1 helicopters. This proposed AD is prompted by reports of corrosion on the main gearbox (MGB) casing lower area between the two servo-control anchoring fitting attachment ribs. An investigation determined that the corrosion was associated with sealing compound on the lower part of the fitting/casing attachment. The proposed actions are intended to detect corrosion on the MGB casing, which could lead to a crack, failure of the MGB, and subsequent loss of control of the helicopter.

DATES: We must receive comments on this proposed AD by August 17, 2012.

ADDRESSES: You may send comments by any of the following methods:

- *Federal eRulemaking Docket:* Go to <http://www.regulations.gov>. Follow the online instructions for sending your comments electronically.

- *Fax:* 202-493-2251.

- *Mail:* Send comments to the U.S. Department of Transportation, Docket Operations, M-30, West Building Ground Floor, Room W12-140, 1200 New Jersey Avenue SE., Washington, DC 20590-0001.

- *Hand Delivery:* Deliver to the "Mail" address between 9 a.m. and 5 p.m., Monday through Friday, except Federal holidays.

Examining the AD Docket: You may examine the AD docket on the Internet at <http://www.regulations.gov> or in person at the Docket Operations Office between 9 a.m. and 5 p.m., Monday through Friday, except Federal holidays. The AD docket contains this proposed AD, the economic evaluation, any comments received, and other information. The street address for the Docket Operations Office (telephone 800-647-5527) is in the **ADDRESSES** section. Comments will be available in the AD docket shortly after receipt.

For service information identified in this proposed AD, contact American Eurocopter Corporation, 2701 Forum Drive, Grand Prairie, TX 75053-4005, telephone (800) 232-0323, fax (972) 641-3710, or at <http://www.eurocopter.com>. You may review a copy of the referenced service information at the FAA, Office of the Regional Counsel, Southwest Region, 2601 Meacham Blvd., Room 663, Fort Worth, Texas 76137.

FOR FURTHER INFORMATION CONTACT: Rao Edupuganti, Aviation Safety Engineer, Regulations and Policy Group, Rotorcraft Directorate, FAA, 2601 Meacham Blvd., Fort Worth, Texas 76137; telephone (817) 222-4389; email: rao.edupaganti@faa.gov.

SUPPLEMENTARY INFORMATION:**Comments Invited**

We invite you to participate in this rulemaking by submitting written comments, data, or views. We also invite comments relating to the economic, environmental, energy, or federalism impacts that might result from adopting the proposals in this document. The most helpful comments reference a specific portion of the proposal, explain the reason for any recommended change, and include supporting data. To ensure the docket does not contain duplicate comments,

commenters should send only one copy of written comments, or if comments are filed electronically, commenters should submit only one time.

We will file in the docket all comments that we receive, as well as a report summarizing each substantive public contact with FAA personnel concerning this proposed rulemaking. Before acting on this proposal, we will consider all comments we receive on or before the closing date for comments. We will consider comments filed after the comment period has closed if it is possible to do so without incurring expense or delay. We may change this proposal in light of the comments we receive.

Discussion

The European Aviation Safety Agency (EASA), which is the Technical Agent for the Member States of the European Union, has issued AD No.: 2011-0127, dated July 1, 2011 (AD No. 2011-0127), which supersedes Directorate General for Civil Aviation (DGAC France) AD F-2008-04, dated June 4, 2008, for the Eurocopter Model EC 155 B, EC 155 B1, SA 365 N, SA 365 N1, AS 365 N2, AS 365 N3, SA 366 G1, SA 365 C, SA 365 C1, SA 365 C2, and SA 365 C3 helicopters with a MGB, all part numbers, that was delivered before December 5, 2007, installed on helicopters delivered before December 5, 2007, or overhauled or repaired before September 30, 2008. EASA states that in 2008, it received two reports of atmospheric corrosion on the MGB casing lower area of two helicopters between the two servo-control anchoring fitting attachment ribs. The investigation showed that the corrosion occurred in this area due to the presence of "PR sealing compound" on the lower part of the fitting/casing attachment. The "PR sealing compound" may have been applied incorrectly on some helicopters due to a misinterpretation of the Eurocopter documentation during installation. EASA states that this condition, if not corrected, could lead to "crack initiation and crack growth in the affected area of the casing," which could cause this area to fail and result in loss of control of the helicopter.

FAA's Determination

These helicopters have been approved by the aviation authority of France and are approved for operation in the United States. Pursuant to our bilateral agreement with France, EASA, its technical representative, has notified us of the unsafe condition described in its AD. We are proposing this AD because we evaluated all known relevant information and determined that an