

Ordering Clause

Pursuant to 47 U.S.C. 154(i), 303(r) and 613, the *Order Suspending Effective Date* is adopted.

Federal Communications Commission.

Marlene H. Dortch,

Secretary.

[FR Doc. 2010-3267 Filed 2-18-10; 8:45 am]

BILLING CODE 6712-01-P

FEDERAL COMMUNICATIONS COMMISSION**47 CFR Part 79**

[CG Docket No. 05-231; ET Docket No. 99-254; FCC 08-255]

Closed Captioning of Video Programming; Closed Captioning Requirements for Digital Television Receivers

AGENCY: Federal Communications Commission.

ACTION: Final rule; announcement of effective date.

SUMMARY: In this document, the Commission announces that the Office of Management and Budget (OMB) has approved, for a period of three years, the information collection associated with the Commission's *Closed Captioning of Video Programming; Closed Captioning Requirements for Digital Television Receivers*, Declaratory Ruling and Order (2008 *Closed Captioning Order*). This notice is consistent with the 2008 *Closed Captioning Order*, which stated that the Commission would publish a document in the **Federal Register** announcing the effective date of those rules.

DATES: 47 CFR 79.1(g)(1) through (5), (i), published at 74 FR 1594, January 13, 2009, is effective February 19, 2010. Video programming distributors must comply with 47 CFR 79.1(i) by March 22, 2010.

FOR FURTHER INFORMATION CONTACT: Amelia Brown, Disabilities Rights Office, Consumer and Governmental Affairs Bureau, at (202) 418-2799 (voice) or (202) 418-7804 (TTY).

SUPPLEMENTARY INFORMATION: This document announces that, on July 27, 2009, OMB approved, for a period of three years, the information collection requirements contained in the Commission's 2008 *Closed Captioning Order*, FCC 08-255, published at 74 FR 1594, January 13, 2009. The OMB Control Number is 3060-0761. The Commission publishes this notice as an announcement of the effective date of the rules. If you have any comments on

the burden estimates listed below, or how the Commission can improve the collections and reduce any burdens caused thereby, please contact Cathy Williams, Federal Communications Commission, Room 1-C823, 445 12th Street, SW., Washington, DC 20554. Please include the OMB Control Number, 3060-0761, in your correspondence. The Commission will also accept your comments via the Internet if you send them to PRA@fcc.gov. To request materials in accessible formats for people with disabilities (braille, large print, electronic files, audio format), send an e-mail to fcc504@fcc.gov or call the Consumer and Governmental Affairs Bureau at (202) 418-0530 (voice), (202) 418-0432 (TTY).

Synopsis

As required by the Paperwork Reduction Act of 1995 (44 U.S.C. 3507), the FCC is notifying the public that it received OMB approval on July 27, 2009, for the information collection requirements contained in the Commission's rules at 47 CFR 79.1(g)(1) through (5) and 47 CFR 79.1(i). The OMB Control Number is 3060-0761. The total annual reporting burden for respondents for these collections of information, including the time for gathering and maintaining the collection of information, is estimated to be: 14,283 respondents, 111,247 responses, a total annual hourly burden of 226,452 hours, and \$38,283,630 in total annual costs.

Under 5 CFR 1320, an agency may not conduct or sponsor a collection of information unless it displays a current, valid OMB Control Number.

No person shall be subject to any penalty for failing to comply with a collection of information subject to the Paperwork Reduction Act, that does not display a current, valid OMB Control Number. The foregoing notice is required by the Paperwork Reduction Act of 1995, Public Law 104-13, October 1, 1995, and 44 U.S.C. 3507.

Federal Communications Commission.

Marlene H. Dortch,

Secretary.

[FR Doc. 2010-3265 Filed 2-18-10; 8:45 am]

BILLING CODE 6712-01-P

DEPARTMENT OF TRANSPORTATION**National Highway Traffic Safety Administration****49 CFR Part 571**

[Docket No. NHTSA-2010-0015

RIN 2127-AK60

Federal Motor Vehicle Safety Standards; Door Locks and Door Retention Components

AGENCY: National Highway Traffic Safety Administration (NHTSA), Department of Transportation (DOT).

ACTION: Final rule; response to petitions for reconsideration; technical amendments.

SUMMARY: This final rule responds to petitions for reconsideration of a February 6, 2007 final rule that amended Federal Motor Vehicle Safety Standard No. 206 to add and update requirements and test procedures and to harmonize with the world's first global technical regulation for motor vehicles. This is the second of two documents responding to the petitions; an earlier final rule delayed the compliance date of the sliding door provisions for a year. In today's document, the agency is granting some aspects of the petitions while denying other aspects, and makes several technical amendments to the regulatory text.

DATES: This rule is effective February 19, 2010. Any petitions for reconsideration of today's final rule must be received by NHTSA not later than April 5, 2010.

ADDRESSES: If you wish to petition for reconsideration of this rule, your petition should refer to the docket number and be submitted to: Administrator, National Highway Traffic Safety Administration, 1200 New Jersey Avenue, SE., West Building, 4th Floor, Washington, DC 20590. Note that all documents received will be posted without change to the docket, including any personal information provided. Please see the Privacy Act discussion under the section entitled, Rulemaking Analyses and Notices.

FOR FURTHER INFORMATION CONTACT: For technical issues, contact Ms. Shashi Kuppa, Office of Crashworthiness Standards, by telephone at (202) 366-4902, or by fax at (202) 366-2990. For legal issues, contact Ms. Sarah Alves, Office of the Chief Counsel, by telephone at (202) 366-2992, or by fax at (202) 366-3820.

Both persons may be reached by mail at the following address: National Highway Traffic Safety Administration,

U.S. Department of Transportation, 1200 New Jersey Avenue, SE., Washington, DC 20590.

SUPPLEMENTARY INFORMATION:

Table of Contents

- I. Background
- II. Summary of Responses to Petitions for Reconsideration
 - a. NHTSA's Part I Response
 - b. Today's Part II Response
- III. Technical Issues
 - a. Sliding Door Requirements and Test Procedures
 - 1. Test Force Application Duration
 - 2. Test Force Application Load Plate Positioning
 - 3. Test Force Application Load Plate Rotation
 - 4. Closure Warning Devices
 - b. Exclusion of Wheelchair Lift Doors
- IV. Other Issues
 - a. Correction of S5.1.1.4(b)(2)
 - b. Technical Amendment to Figure 7
 - c. Distinguishing Between Primary and Auxiliary Door Latches
 - d. Certification Information
 - e. Applicability of the Standard to Vehicles Over 10,000 lb GVWR
- V. GTR Process
- VI. Rulemaking Analyses and Notices

I. Background

Summary of 2007 Final Rule

In this document, NHTSA responds to petitions for reconsideration of its February 6, 2007 final rule adding and updating requirements and test procedures for Federal Motor Vehicle Safety Standard (FMVSS) No. 206, *Door Locks and Door Retention Components* (49 CFR 571.206) (72 FR 5385; Docket No. NHTSA-2006-23882). That rule improved FMVSS No. 206 in several areas, and harmonized with the world's first global technical regulation (GTR) for motor vehicles.¹ Consistent with the GTR, the final rule retained all previously existing provisions in the standard, but added a new full vehicle test procedure for sliding doors, added secondary latched position requirements for doors other than hinged side doors and back doors, provided a new optional test procedure for assessing inertial forces, and extended the application of FMVSS No. 206 to buses with a gross vehicle weight rating (GVWR) of 10,000 pounds (lb) or less, including 12-15 passenger vans. The final rule also eliminated an exclusion from the requirements of the

¹ The U.S. is a Contracting Party of the 1998 Global Agreement which is administered by the U.N. Economic Commission for Europe's World Forum for the Harmonization of Vehicle Regulations (WP.29). The U.S. voted in favor of establishing the GTR at the November 18, 2004 Session of the Executive Committee and was obligated under the Agreement to initiate the process for adopting the provisions of the GTR.

standard for doors equipped with wheelchair platform lifts. The effective date for the final rule was September 1, 2009.

Petitions for Reconsideration

In response to the February 2007 final rule, NHTSA received petitions for reconsideration from the Alliance of Automobile Manufacturers (the Alliance), Ford Motor Company (Ford), Advocates for Highway Safety (Advocates), and Thomas Built Buses, Inc. (Thomas Built Buses). The suggestions of each of the petitioners are summarized below:

- The Alliance petitioned to change the requirements and test procedures for sliding doors and to extend the effective date of the final rule.
 - Ford petitioned NHTSA to extend the effective date of the final rule or at a minimum change the date as it pertains to sliding doors.
 - Advocates questioned the GTR procedure under which the February 2007 final rule was developed. It also petitioned the agency to require sliding doors latches to have secondary latching positions and to remove the option for a visual door closure warning system.
 - Thomas Built Buses petitioned the agency to reinstate the exclusion for wheelchair lift doors on buses with lift platforms that retracts to provide a barrier to occupants being ejected.
- The agency also received a letter from the TriMark Corporation (TriMark), which sought clarification of some provisions of the February 2007 final rule.

II. Summary of Responses to Petitions for Reconsideration

a. NHTSA's Part I Response

To accommodate manufacturers' design and production cycles while allowing the agency more time to analyze the petitions in regards to other issues, the agency published a final rule on July 20, 2009 that delayed the compliance date of the sliding door provisions of S4.2.2 from September 1, 2009, to September 1, 2010. (74 FR 35131; Docket No. NHTSA 2009-0116.) The original effective date of September 1, 2009 for all other provisions was retained. In that final rule, the agency explained that the other issues raised in the petitions for reconsideration would be addressed by the agency in a subsequent document, which we are issuing today.

b. Today's Part II Response

Today's final rule makes the following technical changes to the 2007 final rule. This final rule amends—

- S5.2.2.4(a), to specify a time requirement instead of a load application rate of the sliding door test, which considers the Alliance request while paralleling the GTR requirements;
- S5.2.2.3(f), S5.2.2.3(g)(3), and S5.2.2.3(h)(3), to more accurately specify sliding door test force application load plate positioning;
- S5.2.2.3(f)(1)(ii), S5.2.2.3(g)(1)(ii), and S5.2.2.3(h)(1)(ii), to better define the allowable rotation for test plates; and,
- S4, to reinstate an exclusion of doors equipped with wheelchair lift systems.
- This final rule also corrects provisions in the standard for closing windows and tethering doors during the test (S5.1.1.4(b)(2)(i)(C)), and amends Figure 7 to make the vehicle coordinate reference system for inertial testing consistent with Society of Automotive Engineers (SAE) Standard J211 (Instrumentation for Impact Test) and with the sign conventions used in other Federal motor vehicle safety standards such as FMVSS No. 208, *Occupant Crash Protection*, and FMVSS No. 214, *Side Impact Protection*.

In addition to the above, this final rule responds to the petitions by clarifying or explaining provisions of the 2007 final rule. We also respond to, and deny, Advocates' request that sought a determination that the GTR process under which the final rule was developed is flawed and contrary to the rulemaking procedures required by the Administrative Procedure Act.

III. Technical Issues

a. Sliding Door Requirements and Test Procedures

1. Test Force Application Duration

The February 2007 final rule required that the sliding door test procedure load rate application be applied at any rate not to exceed 2,000 newtons (N) per minute (N/min), until a force of 9,000 N is achieved on each force application device or until either force application device reaches a total displacement of 300 mm (S5.2.2.4(a)). The maximum load is held for 30 seconds.

In its petition for reconsideration, the Alliance requested that NHTSA shorten the load application rate for the sliding door system test procedure. The Alliance stated that testing in accordance with the specifications in S5.2.2.4(a) will require a minimum of 4.5 minutes, because S4.2.2.1 specifies that the "track and slide combination or other supporting means for each sliding door, while in the closed fully latched position, shall not separate from the door frame when a total force of 18,000

N [9,000 N on each side of the door] along the vehicle transverse axis is applied to the door as specified in S5.2.2.” (Dividing the test load, 9,000 N, by the maximum allowable rate of 2,000 N/min produces a duration of approximately 4.5 minutes for each test.) The Alliance requested shortening the test duration to achieve the required force loading in 30 seconds.

The Alliance provided several reasons for its request. The petitioner stated that longer test durations introduce “creep,” or minor sheet metal deformations, that are not representative of the loading that might be experienced in a dynamic crash situation where loads are applied for a fraction of a second.² To illustrate the occurrence of these deformations under sustained load, the Alliance provided the results of a developmental sliding door test that was conducted using a 29-second load application, followed by a 28-second hold, and then a ramp to overload (see Graphs A, B and C in the Alliance petition, Docket No. NHTSA–2006–23882–0007). The figures show that, after the load was stabilized, 29 seconds into the test (33 seconds after the start of data collection as shown in Graph A of the petition) and during the period while the load was held constant, the rear load actuator displaced transversely 6 millimeters (mm) (Graph B) and the upper rear point on the door displaced transversely 8 mm (Graph C).

In its petition, the Alliance stated its belief that because most of the testing that supported the development of the GTR was performed using 10-second load applications, “[m]odifying the procedure in a manner that lengthens the load application duration by a factor of 27 may call into question the cost-benefit analysis” in NHTSA’s Final Regulatory Evaluation (FRE) (Docket No. NHTSA–2006–23882–0002). The

² Metals do not “creep” at room temperature. We assume “creep” describes a yielding or deformation of the material.

Alliance stated that this is because the FRE estimated benefits by comparing the occupant ejection rate through sliding doors equipped with one versus two latches, and estimated costs as those of adding a second latch and striker to vehicles equipped with a single latch. The Alliance implies that the FRE costs may be too low or incomplete because, the petitioner believes, supporting the test loads over a longer period of time may ultimately require additional structure in the vehicle, and such changes were not addressed in NHTSA’s FRE.

On May 22, 2007, the Alliance met with NHTSA to discuss the latter’s concerns with the test force application duration (Docket No. NHTSA–2006–23882–0012). A presentation was given by General Motors (GM) to help explain how “creep” can occur with longer force application durations. The Alliance and GM believed that the creep (yielding) that occurs while maintaining the load could be used to predict the amount of creep (yielding) that will occur while applying the force loads for longer force applications. GM claimed that the increase in deformation that occurs for longer force application durations could be the difference between passing or failing the test. GM also claimed that a load duration of 30 seconds is justified because in tests conducted by Transport Canada and NHTSA’s Vehicle Research & Test Center (VRTC), the peak loads, or the required load limit of 18,000 N (9,000 N of each loading device), could be achieved within this time period.

The Alliance further stated that requiring a load application time of at least 4.5 minutes diverges from the GTR requirement and the GTR’s developmental testing. The GTR specifies a load rate between 20 to 90 mm/min. The Alliance stated that manufacturers will likely specify maximum allowable speed, and that full load will be reached in considerably less than 4.5 minutes. Thus, the Alliance claims that the differences in

load duration now make it possible for a vehicle certified to the GTR in other countries to not comply in the United States.

Agency Response

We are denying the request to shorten the time duration to 30 seconds. A 30-second load rate would unreasonably diminish the stringency of the sliding door load test. However, after considering the Alliance’s petition, the agency has decided that the load application rate up to 2,000 N/min resulted in an unnecessarily long duration for the test. Rather than specifying a force application rate (apply the force at any rate not to exceed 2,000 N/min until a force of 9,000 N is achieved on each force application device), to simplify the test procedure we are amending S5.2.2.4(a) to specify that the 9,000 N force is achieved in not less than 90 seconds and not more than 120 seconds. The 90 to 120 second duration corresponds to loading rates of 4,500 N/min to 6,000 N/min, which according to data from the tests conducted at VRTC is comparable to the loading rates of 20 to 90 mm/min specified in the GTR.

The agency developed the test parameters for the sliding door test specified in the February 2007 final rule based on the results of eight tests conducted by Transport Canada and seven conducted by VRTC. Table 1 below, “Transport Canada and VRTC Sliding Door Evaluation Test Results,” summarizes the results of Transport Canada’s and VRTC’s sliding door tests used to develop the February 2007 final rule. The table identifies the makes and models of the vehicles tested, the number of sliding door latches, the peak loads applied during the test, the approximate time (in seconds) to achieve either 8,900 N or the peak load, the approximate displacement rate (in mm/min) at the peak load, and the approximate loading rate (in N/min).

TABLE 1—TRANSPORT CANADA AND VRTC SLIDING DOOR EVALUATION TEST RESULTS

Model year	Make	Model	Number of latches	Peak loads (N)	Approx. duration to achieve 8,900 N or peak load (sec)*		Approx. displacement rate at peak load (mm/min)*		Approx. loading rate (N/min)*	
					(F)	(R)	(F)	(R)	(F)	(R)
Transport Canada Test Results					(F)	(R)	(F)	(R)	(F)	(R)
1995	Dodge	Caravan	1	(F) 9526 (R) 10008	10	10	150	240	53400	53400
1998	Dodge	Caravan	1	(F) 7239 (R) 11142	13	40	2031	315	33411	16713
2000	Mazda	MPV	1	(F) 10895 (R) 10810	14	14	NA	NA	38143	38143
1999	Honda	Odyssey	1	(F) 6451 (R) 13334	7	13	NA	NA	55294	41077
1997	Chevy	Venture	2	(F) 11129 (R) 11155	12	12	0.59	350	44500	44500
2000	Pontiac	Transport	2	(F) 11148 (R) 11108	14	14	NA	NA	38143	38143
1998	Ford	Windstar	2	(F) 11119 (R) 11088	12	12	NA	NA	44500	44500
1999	Ford	Windstar	2	(F) 11144 (R) 11095	14	14	NA	NA	38143	38143
Averages					12	16	727	302	43129	39327
NHTSA (VRTC) Test Results					(F)	(R)	(F)	(R)	(F)	(R)
1993	Dodge	Caravan	1	(F) 9009 (R) 9018	38.5	38.9	225	315	14040	13909
2001	Dodge	Caravan	1	(F) 7162 (R) 8900	387	260	19.74	18.46	1110	2053
1992	Chevy	Lumina	1	(F) 6266 (R) 6266	21.4	21.4	196	393	17568	17568
2002	Honda	Odyssey (Drv. dr)	1	(F) 7875 (R) 8900	980	340	19.9	19.06	482	1571
2002	Honda	Odyssey (Pass dr.)	1	(F) 7749 (R) 8900	520	300	19.62	20	894	1780
2001	Ford	Windstar (Drv. dr)	2	(F) 8900 (R) 8900	150	340	20	19.4	3560	1571
2001	Ford	Windstar (Pass dr.)	2	(F) 8900 (R) 8900	120	320	22	18.8	4450	1685
Averages					317	231	75	115	6015	5734

* In the column, the first number represents readings for the front force application device (F) and the second represents the rear force application device (R).

Note that the force application rate for the sliding door test specified in the February 2007 final rule was determined using only the data from the VRTC tests. The average time to attain 8,900 N, or peak load, in the VRTC tests was 274 (= (317+231)/2) seconds. This corresponds to the approximate loading rate of 2,000 N/min specified in the final rule.³

In view of the petition for reconsideration, we have reexamined the VRTC test data to review the time

³ The NPRM and the GTR prescribed a load rate application of 20–90 mm/min until a force of 9,000 N is achieved on each of the loading devices, followed by a 10-second hold. In response to the NPRM, the Alliance commented that the test procedure should be controlled using a force application rate rather than a displacement rate, because controllers currently in use do not allow for simultaneous control of both displacement and load, and that the procedure as specified would raise practicability concerns. NHTSA agreed with the comment and adopted in the February 2007 final rule that the load be controlled at a rate not to exceed 2,000 N/min.

durations for conducting the test. We have determined that the average force application rate in the sliding door test at VRTC presented in Table 1 was approximately 6,000 N/min ((6,015+5,734)/2 = 5,874 N/min). This corresponds approximately to an average displacement rate of 95 mm/min ((75+115)/2 = 95 mm/min) which is close to the upper limit of the displacement rate specified in the GTR (90 mm/min). Regarding the lower limit, of the VRTC tests in Table 1 that exhibited displacement rates of approximately 20 mm/min (corresponding to the lower limit of the displacement rate specified in the GTR), the highest corresponding force application rate was approximately 4,500 N/min. Force application rates between 4,500 to 6,000 N/min in the sliding door test correspond to test durations between 90 and 120 seconds. In short, when we calculated the time duration to achieve the test force of

9,000 N when applying the loads at 4,500 N/min and 6,000 N/min (the loading rates resulting in the displacements of 20 mm to 90 mm/min, respectively), we found durations of between 90 and 120 seconds. The 90 to 120 second duration better parallels the GTR requirements. Accordingly, we are modifying the load application rate for the sliding door system test procedure by specifying in S5.2.2.4(a) to increase the force, as linearly as possible, until a force of 9,000 N is achieved on each force application device in not less than 90 seconds and not more than 120 seconds.

We disagree with the petitioner's belief that, because Transport Canada had used the 10-second load application in developing data supporting the GTR, a 10-second load application should be used. The Transport Canada tests were only used to develop the initial procedural aspects of the sliding door tests. We excluded these test results in

calculating the appropriate force application rates for the February 2007 final rule because the test setup was not identical to that specified in the February 2007 final rule. The Transport Canada tests were conducted with the load plates joined by a connecting bar that caused the result of one door edge to affect the other. In addition, the force application device in the Transport Canada tests lacked sufficient structural reinforcement to prevent displacements on the vehicle floor and off-axis loading that could cause the loads to be applied in directions other than transverse.

NHTSA is concerned that testing at exceptionally fast force application rates, such as a 30-second force application rate, will unacceptably reduce the stringency of the sliding door test. Table 1 shows that testing conducted on similar Dodge Caravans (with only one latch system and manufactured from 1992–1995) showed that one vehicle was able to achieve the required loads on both door edges during Transport Canada testing when tested within 10 seconds and at a rate of 53,400 N/min, while the other failed the load requirement when tested by VRTC within 40 seconds and at a rate of approximately 14,000 N/min.⁴

As for the Alliance's concern about the yielding of the metal it saw during the hold period in the Alliance developmental test, we were not persuaded that there was a problem with the test. Yielding in and of itself does not invalidate a test. The yielding could have resulted from a redistribution of loads in the door structure. The petitioner did not provide any specifics of the door used in this developmental sliding door test. We believe that the door was equipped with only a single latch system since the door deformations in this test were in excess of 100 mm, and that the yielding noted by the Alliance could have been avoided had the door been equipped with two latch systems. In any event, because the test duration has been amended by this final rule, the issue is moot.

With regard to the Alliance's concern that the FRE did not include vehicle structural changes, the Alliance comment was not supported by either analysis or data. Although the earlier model year vehicles tested at VRTC failed the sliding door test requirements,

more recent model year vehicles, which had the addition of another door latching system, were able to meet the requirements. In addition, we are not aware of any vehicle requiring significant structural changes to meet the requirements of the sliding door test. Thus, we disagree with the Alliance's assertion that supporting the test loads over a period of time longer than the petitioner's suggested 30-second duration will require additional structure in the vehicle.

2. Test Force Application Load Plate Positioning

The February 2007 final rule specified that "the force application plate is positioned such that the long edge of the plate is as close to the interior edge of the door as possible, but not such that the forward edge of plate is more than 12.5 mm from the interior edge" (S5.2.2.3(f)(3), S5.2.2.3(g)(3), and S5.2.2.3(h)(3)).

The Alliance petitioned NHTSA to slightly revise the wording of the provision because it believes that NHTSA intended to apply this requirement to both the forward edge of the forward plate as well as the rearward edge of the rear plate. Accordingly, the Alliance recommended NHTSA revise the above-mentioned sections to read: "The force application plate is positioned such that the long edge of the plate is as close to the interior edge of the door as possible, but not such that the forward edge of forward plate and the rear edge of the rear plate are more than 12.5 mm from the respective interior edges."

Agency Response

We are granting this request. The Alliance's suggested wording more accurately reflects the intent of the requirement; the suggested wording is clearer that the specification applies to the positioning of both plates. Therefore, we are modifying the specifications for load plate positioning for the sliding door system force application test specified in sections S5.2.2.3(f)(3), S5.2.2.3(g)(3), and S5.2.2.3(h)(3), as suggested by the Alliance.

3. Test Force Application Load Plate Rotation

The February 2007 final rule specified that the force application plates used for applying the force in the sliding door test may "allow for longitudinal rotation with respect to the vehicle's centerline axis" (S5.2.2.3(f)(1)(ii), S5.2.2.3(g)(1)(ii) and S5.2.2.3(h)(1)(ii)). In its petition for reconsideration, the Alliance stated that the final rule's description of the force

application plate rotation is unclear. The Alliance petitioned NHTSA to amend S5.2.2.3(f)(1)(ii), S5.2.2.3(g)(1)(ii), and S5.2.2.3(h)(1)(ii) to read as follows:

The plates are fixed perpendicular to the force application devices and move in the transverse direction. For alignment purposes, each plate is attached to the application device in a manner that allows for rotation about the vehicle's y-axis. In this manner, the face of each plate remains parallel to the vertical plane which passes through the vehicle's longitudinal centerline.

Agency Response

We are granting this request. The Alliance's suggested clarification better defines the allowable rotation for the test plates. The specification as written in the February 2007 final rule does not clearly distinguish which vehicle centerline is being referenced. Therefore, we are modifying the specifications for permissible load plate rotation for the sliding door system force application test in sections S5.2.2.3(f)(1)(ii), S5.2.2.3(g)(1)(ii), and S5.2.2.3(h)(1)(ii), as the petitioner suggested.

4. Closure Warning Devices

In the February 2007 final rule, NHTSA required sliding doors to have either: (1) a primary door latch system that meets the same requirements as primary door latch systems on hinged side doors (i.e., has both a fully and secondary latched position); or (2) a system with a fully latched position and a door closure warning system to alert the driver when the door is not in the fully latched position.⁵ NHTSA explained that FMVSS No. 206 did not previously require either a primary or a secondary latch system for sliding doors; the fully latched position and the associated loading requirements were newly required by the final rule.

The final rule explained that these options for backup protection for sliding door latches have been permitted in the Economic Commission of Europe (ECE) regulations for decades. Further, during the discussions of the GTR, the European governments said there were no data showing better ejection prevention with either of the options. Since NHTSA did not have any data showing a problem with either approach and no commenter provided data showing a problem, NHTSA adopted the

⁴ The Alliance points out in its petition that tests conducted by Transport Canada and by VRTC on the Dodge Caravan and Chevy Lumina were performed within 30 seconds or less. However, these tests were not used for determining the application rate adopted in the final rule since door separation exceeded the limit before a force of 9,000 N was achieved on each force application device.

⁵ Under the first option, the secondary latched position is subject to loads 50% or less of what the fully latched position must meet. The second option contemplates that the driver will close the sliding door so that it is fully latched, thus providing occupants the protection associated with the fully latched loading requirements.

options in the upgraded FMVSS No. 206.

In its petition for reconsideration of the February 2007 final rule, Advocates objected to the option that allows sliding door latches to be equipped with only a primary latching position if a door closure warning system is present. The petitioner had similarly objected to the option in its comments to the NPRM. In its petition, Advocates requested NHTSA to require that all sliding door latches be equipped with both primary and secondary latching positions.

The petitioner believed that the arguments presented by NHTSA in the February 2007 final rule did not sufficiently support NHTSA's decision to oppose Advocates' comment seeking a mandatory secondary latching position on sliding door latches. Advocates stated that lack of clear data was insufficient for denying its request, since door closure warning systems do not ensure the same degree of fail-safe redundancy as would a mechanical secondary latching system. The petitioner argued that "common sense" supports the view that not all drivers will notice or react appropriately to a warning that the primary latching system is not functioning properly.

The petitioner also believed that NHTSA's not requiring a secondary latching position is contradictory to the agency's decision in the final rule with regard to hinged side door locks and was thus "arbitrary and capricious." For hinged side door locks, we require two separate actions to unlatch and then unlock a door from the inside of the vehicle, in part to prevent children from easily opening a door while the vehicle is in motion. Advocates stated that "[e]ven though the agency admitted [in the hinged side door lock situation] that there are no definitive data on the use of child door safety locks, the agency decided that reliance on human behavior would pose a risk to the safety of children." The petitioner believed that the two situations address nearly identical issues of vehicle safety and should be addressed by NHTSA consistently, by requiring a mechanical secondary latching system for side sliding doors.⁶

⁶ The petitioner also believed that the difference in outcomes between the two situations can be explained by NHTSA's participation in the GTR process. "Having forged its position in the international setting, the agency is reluctant to reverse its views it previously espoused in the domestic rulemaking proceeding. This specific instance illustrates the disadvantage at which participants in the domestic APA [Administrative Procedure Act] rulemaking process are placed when that proceeding is superceded [sic] by the prior global rulemaking process under the 1998 Global

Agency Response

We are denying Advocates' request to require that all sliding door latches be equipped with both primary and secondary latching positions. We reiterate our determination in the final rule that the lack of data showing the superiority of one system over the other is noteworthy and important, when the one system at issue⁷ has been in existence for decades in Europe. This is not a situation where we are deliberating whether to permit a system that has been unproven in the real world. The European governments have permitted the system for decades, and available data from Europe do not show better ejection prevention with either of the options. Data also do not show a problem with the systems. Based on the best available information, NHTSA has determined that the systems performed equally. With performance being equal, the agency has concluded that both systems should be permitted. Today's final rule confirms that determination.

This is also not a situation where we relaxed an existing requirement but failed to analyze the basis for changing our previous decisions underlying the requirement. Currently, the only requirement applicable to sliding side doors in FMVSS No. 206 is that the entire door, track and slide entire system must not separate when a total transverse load of 18,000 N is applied. There are no requirements for the individual latch components for sliding doors. The February 2007 final rule newly required the doors to have a backup system for supplemental protection. As to the requirements that should apply to the backup, as explained above, information available to NHTSA from Europe indicates that having either a secondary latched position or a door closure warning system was equivalent. Accordingly, the decision was made to permit either system.

We do not believe we were arbitrary and capricious in not requiring a secondary latching position. The decision not to require a mechanical secondary latching system for side sliding doors was based on different

Agreement." March 23, 2007 petition, page 10. NHTSA seeks to reassure that the GTR process does not detract from or contravene agency rulemaking under the APA and the National Traffic and Motor Vehicle Safety Act (49 U.S.C. 30101 *et seq.*). The discussion in this section responds to the petitioner's specific concerns about the door closing system for side sliding doors and explains why we disagree that a mechanical secondary latching system should be required. In a separate section of this preamble, we respond to the petitioner's overall objections to the GTR process.

⁷ A system with a fully latched position and a door closure warning system.

considerations than the decision to require an action distinct from activation of the door handle to open a door. In the latter situation, NHTSA rejected the Alliance request to permit a door to be unlocked and unlatched with a single pull of the handle when the door is equipped with a child safety lock. The Alliance request pertained to the primary locking mechanism, not to a backup system. There was no alarm or warning provided to the driver informing him or her that the child lock was not engaged. If two distinct actions were not provided to open a rear door, a child could open the door and tumble out by a single pull of the door handle. The safety of the primary system would be too easily overridden by allowing a door to open by a single pull of a handle. Stated differently, the safety of the primary system could be too easily thwarted by human inattention. Further, the requirement for a distinct action to unlock and to open the door has been in FMVSS No. 206 since 1968, and the agency was not convinced there was reason to lessen the requirement.

In contrast, Advocates' request related to a supplemental backup system that has never before been required by the standard. Based on available information, NHTSA selected appropriate requirements for the backup system. Similar to its decision on the child lock issue, the agency did not adopt any requirement for the backup system that would lessen the performance of the primary latching system. We did not allow the backup system to make it easier for a properly latched sliding door to be inadvertently opened. In this regard, the agency's decisions regarding the requirements for the side sliding doors and for the child safety locks are reasonable and consistent. For the reasons stated above, NHTSA denies Advocates' petition to require all sliding door latches to have both primary and secondary latching positions.⁸

⁸ Advocates also believed that a response by the agency to its comment on the NPRM opposing the second option was "inapposite" to the comment. The agency had stated in the final rule: "We believe these new requirements achieve Advocates' suggestion that a mechanical solution is more dependable than one that requires some human behavior." 72 FR at 5391. In its petition, Advocates stated that its NPRM comments had advocated the need to have a mechanical secondary latching system, and that the primary system is mechanical has no relevance to the issue of what means are used to provide the backup system.

A clarification of NHTSA's statement in the final rule would be helpful. The agency was explaining that the February 2007 final rule upgraded the current FMVSS No. 206 such that, among other matters, a latch will have to be provided that has a fully latched position that meets more stringent

b. Exclusion of Wheelchair Lift Doors

The February 2007 final rule removed a provision that had been in the standard since 1985, which excluded from the standard doors equipped with wheelchair lifts.⁹ The doors have been excluded because the agency determined, in response to a petition for rulemaking submitted in the early 1980's from Thomas Built Buses, that a wheelchair lift platform acted as a barricade in the doorway when it was stored. When stored, the platform retracted to a vertical orientation parallel to and in close proximity with the interior surface of the lift door, and covered the complete opening. The 2007 final rule stated that "wheelchair lift designs have evolved such that they no longer provide adequate protection for vehicle occupants as contemplated when the exclusion was adopted," according to a 1998 evaluation. 72 FR at 5396. The agency believed that current lift systems have platforms not covering or only partially covering the vehicle doorway, e.g., some have platforms that are stored horizontally above the vehicle floor. *Id.* NHTSA further noted that current wheelchair lift designs can be

loading requirements than now required. To comply with the final rule's sliding door requirements and test procedure, we believe that manufacturers may have to install two latching systems—on the front and rear edges of the door—rather than only one latching system in only one location. The "mechanical solution" to which the agency referred was to the two-latch system, or an otherwise mechanically enhanced latch system, that would have to be installed to meet the upgraded strength requirements. Further, the agency was acknowledging the final rule's adoption into FMVSS No. 206 a requirement that did not exist before in the standard. That requirement for a backup system (either having a secondary latching position for each of the two sliding door latches or having the vehicle have an alert that the latches are not in the fully latched position) was seen by the agency to further supplement safety by providing a vehicle-based attribute that addressed partial latching of the door.

⁹The door must also be linked to an alarm system consisting of either a flashing visible signal located in the driver's compartment or an alarm audible to the driver that is activated when the door is open. See S4(c) of FMVSS No. 206.

installed without modifying an OEM door system, so that "installation of a wheelchair platform lift does not necessitate removal of a vehicle door from compliance with FMVSS No. 206." *Id.*

In response to the February 2007 final rule, Thomas Built Buses petitioned NHTSA to reinstate the exclusion. The petitioner stated that it uses single panel lift doors that provide a barrier to ejection. It requested excluding a door that "has a wheelchair lift that sets in the wheelchair lift door opening when retracted adequately providing a barrier to bus occupants from being ejected."

Agency Response

We are granting this request. The agency was not aware that lift platforms continued to be manufactured that completely cover the door opening when retracted and act to barricade the doorway. While the former exclusion of all doors equipped with a wheelchair lift was too broad given that some lifts made today do not completely block the door when retracted, the agency sees no reason to subject to FMVSS No. 206 doors with lifts that do block the doorway, as reasoned in the 1985 rulemaking. The agency is amending the February 2009 final rule to exclude doors equipped with a permanently attached wheelchair lift system meeting the following criteria: (a) When the lift is in the retracted position, the lift platform retracts to a vertical orientation parallel to and in close proximity with the interior surface of the lift door; (b) in that position, the platform completely covers the doorway opening and provides a barricade to the doorway; and, (c) the wheelchair lift door is linked to an alarm system consisting of either a flashing visible signal located in the driver's compartment or an alarm audible to the driver that is activated when the door is not fully closed and the vehicle ignition is activated.

IV. Other Issues

a. Correction of S5.1.1.4(b)(2)

In its petition for reconsideration of the February 2007 final rule, the Alliance suggested that the words "if provided" should be included in S5.1.1.4(b)(2) (one of the provisions specifying the test procedure for a hinged door test). The petitioner correctly noted that there is a corresponding section, S5.1.1.4(b)(1)(i)(C), which includes that phrase. We agree to include the phrase, "if provided," in S5.1.1.4(b)(2). The phrase is appropriate for both sections, and the amendment makes the procedures consistent. Also, for additional consistency, we will clarify in this section that doors "may" be tethered to avoid damaging recording equipment.

b. Technical Amendment to Figure 7

Prior to the February 2007 final rule, FMVSS No. 206 did not have a figure that graphically displayed the vehicle coordinate reference system to be used for inertial testing. The GTR provided such a figure because part of the GTR referenced various directions with respect to different vehicle axes. The NPRM proposed, and the February 2007 final rule adopted, this same GTR figure as Figure 7.

Although the agency did not receive any comment regarding Figure 7 in response to both the NPRM and the February 2007 final rule, after publication of the final rule NHTSA realized that x-axis and the z-axis in Figure 7 were not consistent with SAE J211 (Instrumentation for Impact Test) or with the sign conventions used in other Federal motor vehicle safety standards such as FMVSS No. 208 and FMVSS No. 214. Therefore, NHTSA is making a technical amendment to FMVSS No. 206 by modifying Figure 7 to be consistent with SAE J211 and the sign convention for other Federal motor vehicle safety standards as follows:

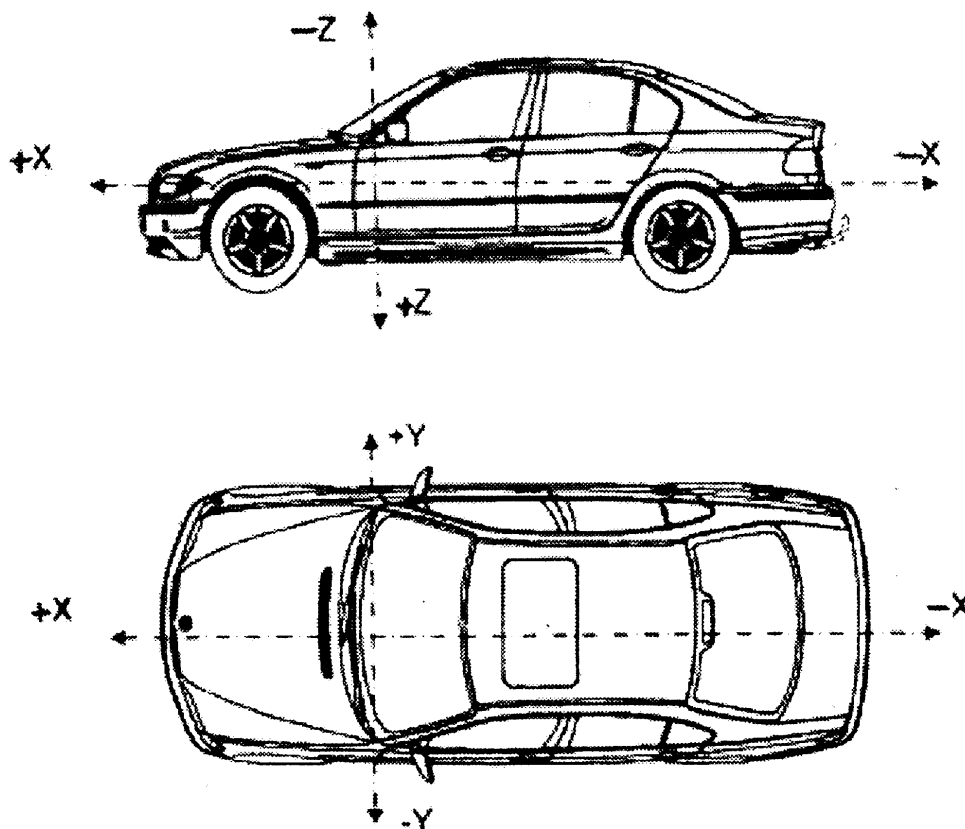
FIGURE 7 • VEHICLE COORDINATE REFERENCE SYSTEM FOR INERTIAL TESTING

X = longitudinal direction
Y = transverse direction
Z = vertical direction

c. Distinguishing Between Primary and Auxiliary Door Latches

The February 2007 final rule mandated that each hinged door system be equipped with at least one “primary door latch system” (S4.1.1). “Primary door latch system” was defined as consisting of a “primary door latch(s) and a striker(s).” A “primary door latch” was defined as “a latch equipped with both a fully latched position and a secondary latched position and is designated as a ‘primary door latch’ by the manufacturer.” The reason for the phrase “and is designated as a ‘primary door latch’ by the manufacturer” was to deal with a potential problem for NHTSA in identifying, for compliance testing purposes, the “primary latch” of a door or door system if the door or door system is also equipped with an auxiliary latch that has a secondary

latch position.¹⁰ If both the primary door latch and the auxiliary latch have a secondary latched position, it is not obvious which latch is the primary latch.

TriMark requested that NHTSA not have “a physical identification of the primary and auxiliary latch because of the cost involved and ability to use a similar/identical latch in both primary and auxiliary applications.” TriMark asked how the agency envisioned that this requirement for latch designation be addressed from a practical matter.

Agency Response

The final rule required the vehicle manufacturer to designate one of the latches as the primary latch in

¹⁰ “Auxiliary door latch” was defined as a latch equipped with a fully latched position, with or without a secondary latched position, and fitted to a door or door system equipped with a primary door latch system.

connection with the manufacturer’s certification of compliance, and to identify the primary door latch when asked to do so by the agency.¹¹ We did not intend, and the final rule did not require, that the primary door latch be physically marked differently on the vehicle than the auxiliary door latch. Door latch suppliers may provide the same latch for both primary and auxiliary applications, if the performance requirements are satisfied. NHTSA continues to believe the approach used in the February 2007 final rule will not be unduly burdensome to latch suppliers. Vehicle manufacturers simply must identify the primary door latch at the time of certification of the vehicle. In practice, prior to conducting a compliance test on

¹¹ Such a request would be made in connection with an agency inquiry regarding compliance with the standard.

a vehicle, NHTSA will ask the manufacturer which is the primary door latch for that vehicle and will test the vehicle in accordance with the manufacturer's response.

d. Certification Information

The February 2007 final rule specifies that each primary and auxiliary door latch system shall meet either dynamic requirements or a calculation of inertial load resistance developed to ensure that the door latch system will remain latched when properly assembled in the vehicle door (S4.1.1.4). TriMark asked if a computer simulation could be used as a method of evaluation for the inertial analysis.

Agency Response

NHTSA does not prohibit a manufacturer from certifying its vehicle based on a method that is different than that specified in the FMVSS. As explained in the final rule, FMVSS test procedures specify the procedures that will be used by the agency to determine if a motor vehicle complies with the applicable requirements. A manufacturer is not required to use the procedures to certify its vehicle. However, NHTSA may ask the vehicle manufacturer for the basis for its certification. In the event of a noncompliance with an FMVSS, a manufacturer may defend itself against civil penalties for violating the National Traffic and Motor Vehicle Safety Act if it could show that it exercised due care in making its certification. Whether a manufacturer exercised due care in basing a certification on a computer simulation depends on the particularities of the case, including the characteristics of the computer simulation, and is determined in the context of a particular compliance proceeding.

e. Applicability of the Standard to Vehicles Over 10,000 lb GVWR

The February 2007 final rule applies to passenger cars, multipurpose passenger vehicles, and trucks. It also applies to buses with a gross vehicle weight rating (GVWR) of 4,536 kg (10,000 lbs) or less. In response to the final rule, Trimark asked NHTSA to comment on the applicability of this standard to motor homes, fire trucks, ambulances, and Class 7/8 heavy trucks in excess of a GVWR of 4,536 kg (10,000 lbs).

Agency Response

With regard to applicability, note 49 CFR 571.3, which provides specific definitions for the vehicle types of concern in the Trimark comment.

Specifically, a *motor home* is defined as "a multi-purpose vehicle with motive power that is designed to provide temporary residential accommodations, as evidenced by the presence of at least four of the following facilities: Cooking; refrigeration or ice box; self-contained toilet; heating and/or air conditioning; a potable water supply system including a faucet and a sink; and a separate 110–125 volt electrical power supply and/or propane." Paragraph S2 of the February 2007 final rule states applicability to multipurpose passenger vehicles;¹² therefore, the 2007 final rule applies to motor homes.

NHTSA considers fire trucks to be a type of *truck*, which is defined in 49 CFR 571.3 as "a motor vehicle with motive power, except a trailer, designed primarily for the transportation of property or special purpose equipment." Since paragraph S2 of the February 2007 final rule states its applicability to trucks, the final rule applies to fire trucks.

Ambulances are typically *multipurpose passenger vehicles* (MPVs) for purposes of the FMVSSs, and thus must meet the standards for MPVs (including FMVSS No. 206). In addition, ambulances are also subject to regulation through separate standards administered by the General Services Administration (GSA) in the *Federal Specifications for the Star-of-Life Ambulance*.¹³ Section 3.10.9 of the GSA standard states, "Door latches, hinges, and hardware furnished by original equipment manufacturers and final stage ambulance manufacturers shall comply with FMVSS 206."

Regarding Class 7/8 heavy trucks, these vehicles fall under the definition of *truck* as defined in 49 CFR 571.3. FMVSS No. 206 applied to trucks, regardless of their GVWR, prior to the February 2007 final rule, as does the amended FMVSS No. 206. S2 of amended FMVSS No. 206 states that the standard applies to "passenger cars, multipurpose passenger vehicles, and trucks, and buses with a gross vehicle weight rating (GVWR) of 4,536 kg or less" (emphasis added). In other words, the February 2007 final rule applies to all passenger cars, multipurpose passenger vehicles, and trucks, regardless of their GVWR, and is also

¹² "Multipurpose passenger vehicle" means a motor vehicle with motive power, except a low-speed vehicle or trailer, designed to carry 10 persons or less which is constructed either on a truck chassis or with special features for occasional off-road operation." 49 CFR 571.3.

¹³ See KKK-A-1822F (Aug. 1, 2007), available at <http://www.deltaveh.com/KKK-A-1822F.htm>. This standard was created by the U.S. General Services Administration as a guideline for the proper construction of an ambulance.

applicable to buses with a GVWR of 4,536 kg (10,000 lb) or less.¹⁴

V. GTR Process

The February 2007 final rule responded to a comment from Advocates that had expressed concern about the opportunity for consumer organizations to be involved in the GTR process, and about what Advocates had said was an "after-the-fact" presentation of a draft GTR which, the commenter believed, threatened to abridge the agency's authority. In responding to the comment, the final rule sought to address what appeared to be Advocates' fundamental misunderstanding of the GTR process. NHTSA clarified in the final rule that consumer groups have an opportunity to be involved in all aspects of the GTR process, and explained how the process is transparent and inviting of public participation in the formation of draft proposals. 72 FR at 5388. The final rule explained how information regarding the meetings and negotiations was made publicly available through **Federal Register** notices, and that meeting agendas, presentations, reports and test results were made available to the public on the UNECE Web site after each international meeting. The final rule pointed out that public comment on the GTR discussions were requested multiple times, and that domestic consumer organizations were able to participate in the GTR negotiations as a part of Consumer International. Importantly, the final rule explained that under the GTR process, countries voting "yes" on a GTR have only agreed to begin their processes for adopting the provisions of the GTR, i.e., to issue an NPRM or Advance NPRM. The GTR process leaves the ultimate decision to each country of whether to adopt the GTR into their domestic law. That is, the process leaves it up to NHTSA to decide whether to issue a final rule adopting the proposed requirements into the FMVSS, after receiving and considering comments on the NPRM.

In its petition for reconsideration, Advocates repeated many of the concerns it had expressed in its comment on the NPRM. The petitioner again described its belief that the procedure under which the final rule was developed was flawed. The petitioner believed that the final rule was negotiated in proceedings with foreign stakeholders since, Advocates stated, only international organizations having standing to participate at UNECE

¹⁴ The preamble of the final rule explained that it "extends the application of FMVSS No. 206 to buses with a gross vehicle weight rating (GVWR) of 4,536 kg (10,000 pounds) or less, including 12–15 passenger vans." 72 FR 5385, 5386.

sponsored Working Party on Passive Safety committee meetings are allowed to “influence” the GTR negotiations. (Advocates stated that U.S. consumer groups were unable to participate in the GTR negotiations as a part of Consumer International, a group with standing, because of cost and location constraints.)

The petitioner also believed that by participating in the GTR process and adopting the GTR, NHTSA subverted the rulemaking procedures required by the Administrative Procedure Act (APA) (5 U.S.C. 553). Advocates stated that the purpose of the APA notice and comment rulemaking requirement is to ensure that the U.S. public is able to comment on the rule while it is still in the formative or proposed stage. The petitioner believed that, because the U.S. will have already voted for the GTR when NHTSA presents it as a proposed rule, the APA proceeding is tainted because the agency has put its credibility on the line in adopting the GTR. Advocates contended that as a result of this, the agency’s commitment to the international process and the GTR/proposed rule makes the agency more resistant to adopting changes and alternatives and prejudices Advocates’ participation in the rulemaking proceeding.

Agency Response

We appreciate this opportunity to explain again the GTR process and to address the petitioner’s reservations about the process. The GTR process under the UN/ECE 1998 Agreement on Global Technical Regulations provides opportunities for NHTSA to enhance vehicle safety and improve government efficiency. It assists us in adopting best safety practices from around the world, identifying and reducing unwarranted regulatory requirements, and leveraging scarce government resources for research and regulation. The process facilitates our effort to continuously improve and seek high levels of safety, particularly by helping us develop regulations that reflect a global consideration of current and anticipated technology and safety problems.¹⁵

The final rule described in detail the benefits that the GTR process afforded the American public in the development of the upgraded FMVSS No. 206. 72 FR 5388, col. 3. It also explained the high degree to which public participation was pursued and encouraged by NHTSA in developing the NPRM and final

rule.¹⁶ Advocates is concerned about its inability to be directly involved at international meetings. Attendance at the meetings by non-governmental parties is not crucial to the process. Alternative opportunities are provided for participation, such as by commenting to agency notices of WP.29 programs of work.¹⁷ Moreover, the point at which public participation is crucial, and where Advocates is wholly able to participate, is subsequent and in response to publication of NHTSA’s NPRM. The GTR process recognizes and embraces that participation and fully accords with the requirements of the APA.

Under the APA, an administrative agency must issue a notice of the intention to adopt rules, which must contain either the terms or substance of the proposed rule or a description of the subjects and issues involved. *See* 5 U.S.C. 553. The APA requires that an agency must issue an NPRM that must be published in the **Federal Register**, unless persons subject thereto are named and either personally served or otherwise have actual notice thereof in accordance with law. *Id.* at § 553(b). Notice under § 553(b) is sufficient if it affords interested parties a reasonable and meaningful opportunity to participate in the rulemaking process by providing a description of the subjects and issues involved.¹⁸ Under the APA, following publication of an NPRM a Federal agency must give interested persons an opportunity to participate in the rulemaking through submission of written data, views, or arguments. *Id.* at § 553(c). There is no requirement in the APA for public participation in formation of the NPRM.¹⁹

¹⁶ *Id.*, col. 2.

¹⁷ Advocates did participate in the GTR process via the opportunity to submit comments to several notices published by NHTSA concerning the GTR process. Advocates did in fact take advantage of this opportunity by submitting comments in response to a 2003 notice NHTSA issued regarding activities under the UNECE 1998 Agreement. *See* Docket No. NHTSA–2003–14395–0005 (March 5, 2003) (submitted in response to Notice of activities under the 1998 Global Agreement and request for comments, 68 FR 5333, February 3, 2003). Advocates also submitted comments to other notices announcing information on other international negotiations. *See* Docket No. NHTSA–2000–7638–0014 (Sept. 11, 2000) (submitted in response to NHTSA’s Recommendations for Global Technical Regulations Under the UNECE 1998 Global Agreement, 65 FR 44565, July 18, 2000).

¹⁸ The APA further requires that the NPRM must also include (1) a statement of the time, place, and nature of public rulemaking proceedings; (2) reference to the legal authority under which the rule is proposed; and (3) either the terms or substance of the proposed rule or a description of the subjects and issues involved. *Id.*

¹⁹ Advocates cites to the Negotiated Rulemaking Procedure provisions, 5 U.S.C. 561–570a, as authority that those prescribed procedures are the

The GTR process and NHTSA’s policy implementing the process²⁰ were developed with these APA requirements for notice and opportunity to comment foremost in mind. Following a vote by the U.S. for establishment of a GTR, our procedure entails publishing an NPRM requesting public comment on adopting the regulation as a U.S. standard. Any decision by us as to the next agency action with regard to the NPRM (whether to issue a final rule adopting the regulation, a supplemental NPRM, or a notice terminating the rulemaking action) is made in accordance with applicable U.S. law, after careful consideration and analysis of public comments.²¹ With regard to the rulemaking at issue, NHTSA met the APA with the NPRM (December 15, 2004) and the subsequent final rule (February 7, 2007). We thoroughly analyzed and considered Advocates’ comments to the NPRM (*see* 72 FR 5385, 5388–5391). Our disagreement with the petitioner’s comments was based upon our analysis of the issues presented and our conclusion that the views expressed by the commenter were unpersuasive.

Advocates believes that NHTSA failed to accept its suggestions because NHTSA would lose face in the international community. This is an erroneous and unfortunate view of the agency and the GTR process. When the agency meets with international parties to consider current and anticipated technology and safety problems, NHTSA is seeking to learn from the expertise and experience of governmental bodies and consumer and industry groups worldwide at a preliminary stage in the rulemaking. The agency determines in that dialogue the best practices of other countries or regions, and whether there is a bases and rationale for those practices. When the agency votes for establishment of the GTR, the agency is acknowledging that it has made an initial determination that there appears to be a technical basis for the regulation and that the motor vehicle problem the agency seeks to address in the U.S. could possibly be addressed by the GTR. A similar kind of determination is made when we decide,

only permissible method by which agencies can consult with outside parties in establishing the content of proposed rules. In fact, the stated purpose of the Negotiated Rulemaking Procedure subchapter is “to encourage the agencies to use the process when it enhances the informal rulemaking process.” 5 U.S.C. 561. Significantly, “[n]othing in this subchapter should be construed as an attempt to limit innovation and experimentation with the negotiated rulemaking process or with other innovative rulemaking procedures otherwise authorized by law.” *Id.*

²⁰ 49 CFR Part 553, Appendix C.

²¹ *Id.*

¹⁵ *See*, 49 CFR Part 553, Appendix C, “Statement of Policy: Implementation of the United Nations/Economic Commission for Europe (UN/ECE) 1998 Agreement on Global Technical Regulations—Agency Policy Goals and Public Participation.”

in our non-GTR rulemakings, to go forward and publish a proposal or advance notice of proposed rulemaking in the **Federal Register**. We fully acknowledge and hold in high consideration that “the decision to issue a final rule will be made in accordance with the U.S. law and only after careful consideration and analysis of public comments.” 49 CFR Part 553, Subpart C. NHTSA values and learns from public comment on its NPRMs and shapes its decisions on rulemaking proposals based on those comments.²²

The APA does not prohibit Federal agencies from developing proposals or having dialogues with any particular group (including international communities) prior to the issuance of a notice of proposed rulemaking. To the extent the petitioner asks us to refrain from such dialogue, we do not believe that public policy would be served by limiting the GTR’s pre-proposal proceedings. The GTR provides a forum to share information and resources that could facilitate the development of a possible rulemaking initiative that might address a motor vehicle safety problem in the U.S. The process advances our research and rulemaking efforts and enables us to better leverage scarce agency resources through partnering with other countries. It provides us an opportunity and means to better manage our resources and address more motor vehicle safety harm, and more rapidly, than would be possible by NHTSA acting alone.

Advocates correctly states that the legal standard for sufficiency of APA notice is that “parties be able to comment on the rule while it is still in the formative or ‘proposed’ stage.” *See, National Tour Brokers Ass’n v. US*, 591 F.2d 896, 902 (D.C. Cir. 1978). Yet, the petitioner does not believe that NHTSA can maintain a flexible and open-minded attitude towards an NPRM developed in the GTR process. We strongly disagree, and note that Advocates has made no showing that the agency has been closed-minded to the comments other than to assert that as the cause underlying the agency’s decision not to concur with its suggestions. The NPRM laid out in detail reasons in support of each GTR

provision, and NHTSA thoroughly considered and addressed all comments in the final rule. Also, as mentioned previously, the final rule (and today’s document) changed some provisions of the GTR, which demonstrates the agency’s flexibility in reconsidering tentative decisions made in the NPRM stage. To the extent that NHTSA did not adopt provisions that Advocates supported or suggested, that is a reflection of the agency’s determination that those provisions were not the best way to proceed.

Comments were requested on the NPRM when the rule was still in the proposed stage. When NHTSA issues an NPRM, including those formed in the GTR process, the agency is seeking to enhance its knowledge of the subject matter. We know there may be issues bearing on the substance of the rulemaking that the agency has not fully understood or perhaps whose significance the agency may not have even recognized. We seek to be as informed as possible, so as to make the best decisions possible armed with all available information. NHTSA’s implementation of the GTR process recognizes the crucial role of public participation in the development of regulations. At the same time, however, the GTR process enhances NHTSA’s knowledge about safety problems and possible solutions by facilitating the interaction of the agency with safety specialists from around the world at the pre-NPRM stage. This knowledge improves our efficiency and enhances the quality of the FMVSS that may be ultimately proposed. For the aforementioned reasons, we are denying Advocates’ request to reconsider the final rule based upon its view that the GTR process is flawed or that NHTSA violated APA rulemaking procedures.

VI. Rulemaking Analyses and Notices

Executive Order 12866 and DOT Regulatory Policies and Procedures

This rulemaking document was not reviewed by the Office of Management and Budget under E.O. 12866. It is not considered to be significant under E.O. 12866 or the Department’s Regulatory Policies and Procedures (44 FR 11034; February 26, 1979). Although the February 6, 2007 final rule was significant due to public interest in the issues, today’s document makes minor amendments to the regulatory text of that final rule. The minimal impacts of today’s amendment do not warrant preparation of a regulatory evaluation.

Executive Order 13132 (Federalism)

NHTSA has examined today’s final rule pursuant to Executive Order 13132 (64 FR 43255, August 10, 1999) and concluded that no additional consultation with States, local governments or their representatives is mandated beyond the rulemaking process. The agency has concluded that the rule does not have federalism implications because the rule does not have “substantial direct effects on the States, on the relationship between the national government and the States, or on the distribution of power and responsibilities among the various levels of government.”

Further, no consultation is needed to discuss the issue of preemption in connection with today’s rule. The issue of preemption can arise in connection with NHTSA rules in at least two ways. First, the National Traffic and Motor Vehicle Safety Act contains an express preemptive provision: “When a motor vehicle safety standard is in effect under this chapter, a State or a political subdivision of a State may prescribe or continue in effect a standard applicable to the same aspect of performance of a motor vehicle or motor vehicle equipment only if the standard is identical to the standard prescribed under this chapter.” 49 U.S.C. 30103(b)(1). It is this statutory command that preempts State law, not today’s rulemaking, so consultation would be unnecessary.

Second, the Supreme Court has recognized the possibility of implied preemption: in some instances, State requirements imposed on motor vehicle manufacturers, including sanctions imposed by State tort law, can stand as an obstacle to the accomplishment and execution of a NHTSA safety standard. When such a conflict is discerned, the Supremacy Clause of the Constitution makes the State requirements unenforceable. *See Geier v. American Honda Motor Co.*, 529 U.S. 861 (2000). However, NHTSA has considered the nature and purpose of today’s final rule and does not currently foresee any potential State requirements that might conflict with it. Without any conflict, there could not be any implied preemption.

Executive Order 13045

E.O. 13045 (62 FR 19885, April 23, 1997) applies to any rulemaking that: (1) is determined to be “economically significant” as defined under E.O. 12866, and (2) concerns an environmental, health or safety risk that NHTSA has reason to believe may have a disproportionate effect on children.

²² To illustrate, in response to comments on the NPRM, NHTSA’s February 2007 final rule changed some of the requirements that had been proposed. In accordance with Alliance’s comments to the NPRM, the load application in the sliding door test that was specified in the NPRM in terms of the displacement rate of the load application device was modified in the final rule to be specified in terms of the rate of load application. Along those lines, today’s final rule has also amended provisions of the GTR in response to petitions for reconsideration.

This rulemaking is not subject to the Executive Order because it is not economically significant as defined in E.O. 12866.

Executive Order 12988 (Civil Justice Reform)

With respect to the review of the promulgation of a new regulation, section 3(b) of Executive Order 12988, "Civil Justice Reform" (61 FR 4729, February 7, 1996) requires that Executive agencies make every reasonable effort to ensure that the regulation: (1) Clearly specifies the preemptive effect; (2) clearly specifies the effect on existing Federal law or regulation; (3) provides a clear legal standard for affected conduct, while promoting simplification and burden reduction; (4) clearly specifies the retroactive effect, if any; (5) adequately defines key terms; and (6) addresses other important issues affecting clarity and general draftsmanship under any guidelines issued by the Attorney General. This document is consistent with that requirement.

Pursuant to this Order, NHTSA notes as follows. The issue of preemption is discussed above in connection with E.O. 13132. NHTSA notes further that there is no requirement that individuals submit a petition for reconsideration or pursue other administrative proceeding before they may file suit in court.

Regulatory Flexibility Act

Pursuant to the Regulatory Flexibility Act (5 U.S.C. 601 *et seq.*, as amended by the Small Business Regulatory Enforcement Fairness Act (SBREFA) of 1996) whenever an agency is required to publish a notice of rulemaking for any proposed or final rule, it must prepare and make available for public comment a regulatory flexibility analysis that describes the effect of the rule on small entities (*i.e.*, small businesses, small organizations, and small governmental jurisdictions). However, no regulatory flexibility analysis is required if the head of an agency certifies the rule would not have a significant economic impact on a substantial number of small entities. SBREFA amended the Regulatory Flexibility Act to require Federal agencies to provide a statement of the factual basis for certifying that a rule would not have a significant economic impact on a substantial number of small entities.

I certify that this final rule does not have a significant economic impact on a substantial number of small entities. This rule affects motor vehicle manufacturers, multistage manufacturers and alterers. To the extent some of these entities qualify as

small businesses, they will not be significantly affected by this rulemaking. This final rule does not establish new requirements, but instead only adjusts some test procedures and makes minor technical amendments to the February 2007 final rule.

National Environmental Policy Act

We have analyzed this final rule for the purposes of the National Environmental Policy Act and determined that it does not have any significant impact on the quality of the human environment.

Paperwork Reduction Act

Under the Paperwork Reduction Act of 1995, a person is not required to respond to a collection of information by a Federal agency unless the collection displays a valid Office of Management and Budget (OMB) control number. The final rule does not have any requirements that are considered to be information collection requirements as defined by OMB in 5 CFR part 1320.

National Technology Transfer and Advancement Act

Section 12(d) of the National Technology Transfer and Advancement Act of 1995 (NTTAA), Public Law 104-113, section 12(d) (15 U.S.C. 272) directs us to use voluntary consensus standards in its regulatory activities unless doing so would be inconsistent with applicable law or otherwise impractical. Voluntary consensus standards are technical standards (*e.g.*, materials specifications, test methods, sampling procedures, and business practices) that are developed or adopted by voluntary consensus standards bodies, such as the Society of Automotive Engineers (SAE). The NTTAA directs us to provide Congress, through OMB, explanations when we decide not to use available and applicable voluntary consensus standards.

No voluntary consensus standards were used in developing today's final rule. This final rule only adjusts some test procedures and makes minor technical amendments to the February 2007 final rule. There are no voluntary standards that address the subject of this rulemaking.

Unfunded Mandates Reform Act

Section 202 of the Unfunded Mandates Reform Act of 1995 (UMRA) requires Federal agencies to prepare a written assessment of the costs, benefits and other effects of proposed or final rules that include a Federal mandate likely to result in the expenditure by State, local or tribal governments, in the

aggregate, or by the private sector, of more than \$100 million in any one year (adjusted for inflation with base year of 1995). Before promulgating a NHTSA rule for which a written statement is needed, section 205 of the UMRA generally requires us to identify and consider a reasonable number of regulatory alternatives and adopt the least costly, most cost-effective or least burdensome alternative that achieves the objectives of the rule. The provisions of section 205 do not apply when they are inconsistent with applicable law. Moreover, section 205 allows us to adopt an alternative other than the least costly, most cost-effective or least burdensome alternative if we publish with the final rule an explanation why that alternative was not adopted.

The final rule will not impose any unfunded mandates under the Unfunded Mandates Reform Act of 1995. This rulemaking does not meet the definition of a Federal mandate because it would not result in costs of \$100 million (adjusted annually for inflation with a base year of 1995 or 116 million in 2003 dollars) or more to either State, local, or tribal governments, in the aggregate, or to the private sector. Thus, this rulemaking is not subject to the requirements of sections 202 and 205 of the UMRA.

Plain Language

Executive Order 12866 requires each agency to write all rules in plain language. Application of the principles of plain language includes consideration of the following questions:

- Has the agency organized the material to suit the public's needs?
- Are the requirements in the rule clearly stated?
- Does the rule contain technical language or jargon that is not clear?
- Would a different format (grouping and order of sections, use of headings, paragraphing) make the rule easier to understand?
- Would more (but shorter) sections be better?
- Could we improve clarity by adding tables, lists, or diagrams?
- What else could we do to make the rule easier to understand?

If you have any responses to these questions, please write to us about them.

Regulation Identifier Number (RIN)

The Department of Transportation assigns a regulation identifier number (RIN) to each regulatory action listed in the Unified Agenda of Federal Regulations. The Regulatory Information Service Center publishes the Unified

Agenda in April and October of each year. You may use the RIN contained in the heading at the beginning of this document to find this action in the Unified Agenda.

Privacy Act

Please note that anyone is able to search the electronic form of all documents received into any of our dockets by the name of the individual submitting the document (or signing the document, if submitted on behalf of an association, business, labor union, etc.). You may review DOT's complete Privacy Act Statement in the Federal Register published on April 11, 2000 (65 FR 19477-78) or you may visit http://www.dot.gov/privacy.html.

List of Subjects in 49 CFR Part 571

Motor vehicle safety, Report and recordkeeping requirements, Tires.

In consideration of the foregoing, NHTSA amends 49 CFR part 571 as follows:

PART 571—FEDERAL MOTOR VEHICLE SAFETY STANDARDS

1. The authority citation for part 571 continues to read as follows:

Authority: 49 U.S.C. 322, 30111, 30115, 30117, and 30166; delegation of authority at 49 CFR 1.50.

2. Section 571.206 is amended by revising paragraphs S4, S5.1.1.4(b)(2)(i)(C), S5.2.2.3(f)(1)(ii), S5.2.2.3(f)(3), S5.2.2.3(g)(1)(ii), S5.2.2.3(g)(3), S5.2.2.3(h)(1)(ii), S5.2.2.3(h)(3), S5.2.2.4(a), and Figure 7 to read as follows:

§ 571.206 Standard No. 206; Door locks and door retention components.

S4. Requirements. The requirements apply to all side and back doors, that lead directly into a compartment that contains one or more seating accommodations and the associated door components, except for those on folding doors, roll-up doors, detachable doors, bus doors used only for emergency egress purposes and labeled accordingly and on bus doors to

accommodate a permanently attached wheelchair lift system that when the device is in the retracted position, the lift platform retracts to a vertical orientation parallel to and in close proximity with the interior surface of the lift door and in that position, the platform completely covers the doorway opening, has fixed attachments to the vehicle and provides a barricade to the doorway. The bus wheelchair lift door must be linked to an alarm system consisting of either a flashing visible signal located in the driver's compartment or an alarm audible to the driver that is activated when the door is not fully closed and the vehicle ignition is activated.

* * * * *

S5.1.1.4 * * *

(b) * * *

(2) * * *

(i) * * *

(C) Ensure that the door latch is in the fully-latched position, that the door is unlocked (doors may be tethered to avoid damaging the recording equipment), and that any windows, if provided, are closed.

* * * * *

S5.2.2.3 * * *

(f) * * *

(1) * * *

(ii) The plates are fixed perpendicular to the force application devices and move in the transverse direction. For alignment purposes, each plate is attached to the application device in a manner that allows for rotation about the vehicle's y-axis. In this manner, the face of each plate remains parallel to the vertical plane which passes through the vehicle's longitudinal centerline.

* * * * *

(3) The force application plate is positioned such that the long edge of the plate is as close to the interior edge of the door as possible, but not such that the forward edge of forward plate and the rear edge of the rear plate are more than 12.5 mm from the respective interior edges.

(g) * * *

(1) * * *

(ii) The plates are fixed perpendicular to the force application devices and move in the transverse direction. For alignment purposes, each plate is attached to the application device in a manner that allows for rotation about the vehicle's y-axis. In this manner, the face of each plate remains parallel to the vertical plane which passes through the vehicle's longitudinal centerline.

* * * * *

(3) The force application plate is positioned such that the long edge of the plate is as close to the interior edge of the door as possible, but not such that the forward edge of forward plate and the rear edge of the rear plate are more than 12.5 mm from the respective interior edges.

(h) * * *

(1) * * *

(ii) The plates are fixed perpendicular to the force application devices and move in the transverse direction. For alignment purposes, each plate is attached to the application device in a manner that allows for rotation about the vehicle's y-axis. In this manner, the face of each plate remains parallel to the vertical plane which passes through the vehicle's longitudinal centerline.

* * * * *

(3) The force application plate is positioned such that the long edge of the plate is as close to the interior edge of the door as possible, but not such that the forward edge of forward plate and the rear edge of the rear plate are more than 12.5 mm from the respective interior edges.

* * * * *

S5.2.2.4 Test Procedure.

(a) Increase the force on each force application device as linearly as practicable until a force of 9,000 N is achieved on each force application device in not less than 90 seconds and not more than 120 seconds, or until either force application device reaches a total displacement of 300 mm.

* * * * *

TABLES AND FIGURES TO § 571.206

* * * * *

FIGURE 7 - VEHICLE COORDINATE REFERENCE SYSTEM FOR INERTIAL TESTING

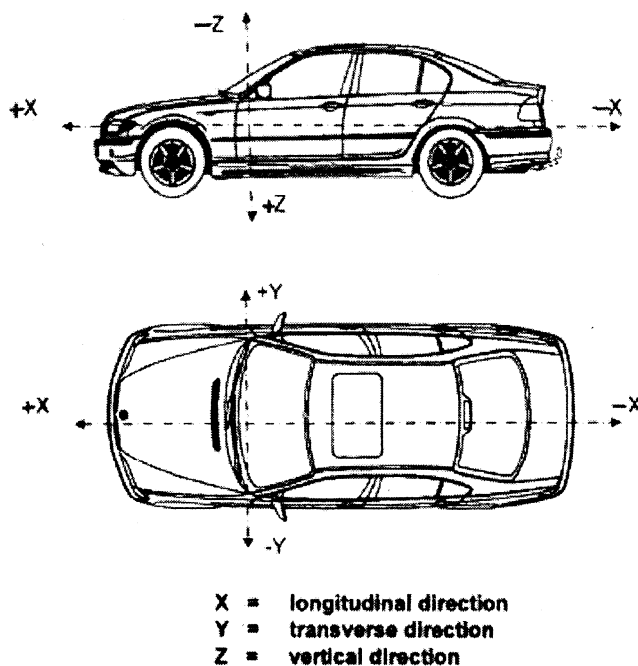

* * * * *

Issued: February 4, 2010.

David L. Strickland,
Administrator.

[FR Doc. 2010-2837 Filed 2-18-10; 8:45 am]

BILLING CODE 4910-59-P

DEPARTMENT OF COMMERCE**National Oceanic and Atmospheric Administration****50 CFR Part 229**

[Docket No. 080721862-8864-01]

RIN 0648-AW51

Taking of Marine Mammals Incidental to Commercial Fishing Operations; Harbor Porpoise Take Reduction Plan Regulations**AGENCY:** National Marine Fisheries Service (NMFS), National Oceanic and Atmospheric Administration (NOAA), Commerce.**ACTION:** Final rule.**SUMMARY:** NMFS issues this final rule to amend the regulations implementing the Harbor Porpoise Take Reduction Plan (HPTRP) to address the increased incidental mortality and serious injury of the Gulf of Maine/Bay of Fundy (GOM/BOF) stock of harbor porpoises (*Phocoena phocoena*) in gillnet fisheries throughout the stock's U.S. range.**DATES:** Effective March 22, 2010.**ADDRESSES:** Copies of the final Environmental Assessment (EA) and Regulatory Impact Review/Final Regulatory Flexibility Analysis (RIR/FRFA) for this action, as well as the Harbor Porpoise Take Reduction Team (HPTRT) meeting summaries and supporting documents, may be obtained from the HPTRP Web site (<http://www.nero.noaa.gov/hptrp>) or by writing to Diane Borggaard, NMFS, Northeast Region, Protected Resources Division, 55 Great Republic Drive, Suite 04-400, Gloucester, MA 01930.**FOR FURTHER INFORMATION CONTACT:** Amanda Johnson, NMFS, Northeast Region, 978-282-8463, amanda.johnson@noaa.gov; or Melissa Andersen, NMFS, Office of Protected Resources, 301-713-2322, melissa.andersen@noaa.gov.**SUPPLEMENTARY INFORMATION:****Background**

The HPTRP was developed pursuant to section 118(f) of the Marine Mammal Protection Act (MMPA), 16 U.S.C. 1361-1423h, to reduce the level of serious injury and mortality of the GOM/BOF stock of harbor porpoises. This final rule implements modifications to the HPTRP to address increased mortalities of harbor porpoises in commercial gillnet fisheries due to non-compliance with the HPTRP requirements and observed interactions occurring outside of

existing HPTRP management areas. These modifications implement measures that apply to both the New England and Mid-Atlantic portions of the HPTRP.

Recent harbor porpoise bycatch estimates indicate that, when calculating the average estimated mortality for the period between 2002 and 2006, bycatch exceeded the stock's potential biological removal level (PBR). The 2008 Stock Assessment Report (SAR) indicates that the current annual estimated harbor porpoise incidental bycatch is 866 animals per year, which exceeds the current PBR of 610 animals (Waring *et al.*, 2009). In December 2007, NMFS reconvened the HPTRT to discuss the most recent harbor porpoise abundance and bycatch information for gillnet fisheries from Maine through North Carolina. The HPTRT used this information to develop a suite of recommended modifications to the HPTRP that would reduce takes to below the stock's PBR level and to a rate approaching a zero mortality and serious injury rate, known as the zero mortality rate goal (ZMRG), which is defined as 10 percent of PBR. The recommendations included expanding seasonal and temporal requirements within the HPTRP management areas, incorporating additional management areas, and creating areas that would seasonally close to gillnet fisheries if certain levels of harbor porpoise bycatch