

DEPARTMENT OF TRANSPORTATION

National Highway Traffic Safety Administration

49 CFR Parts 571 and 585

[Docket No. NHTSA-29134]

RIN 2127-AJ10

Federal Motor Vehicle Safety Standards; Occupant Protection in Interior Impact; Side Impact Protection; Fuel System Integrity; Electric-Powered Vehicles: Electrolyte Spillage and Electrical Shock Protection; Side Impact Phase-In Reporting Requirements

AGENCY: National Highway Traffic Safety Administration (NHTSA), Department of Transportation.

ACTION: Final rule.

SUMMARY: This final rule incorporates a dynamic pole test into Federal Motor Vehicle Safety Standard (FMVSS) No. 214, "Side impact protection." To meet the test, vehicle manufacturers will need to assure head and improved chest protection in side crashes. It will lead to the installation of new technologies, such as side curtain air bags and torso side air bags, which are capable of improving head and thorax protection to occupants of vehicles that crash into poles and trees and vehicles that are laterally struck by a higher-riding vehicle. The side air bag systems installed to meet the requirements of this final rule will also reduce fatalities and injuries caused by partial ejections through side windows.

Vehicles will be tested with two new, scientifically advanced test dummies representing a wide range of occupants, from mid-size males to small females. A test dummy known as the ES-2re will represent mid-size adult male occupants. A test dummy known as the SID-IIs will represent smaller stature occupants. The SID-IIs is the size of a 5th percentile adult female.

This final rule also enhances FMVSS No. 214's moving deformable barrier (MDB) test. The current 50th percentile male dummy in the front seat of tested vehicles will be replaced with the more biofidelic ES-2re. In the rear seat, the new 5th percentile female SID-IIs dummy will be used, thus improving protection to a greater segment of occupants seated in rear seating positions.

The "Safe, Accountable, Flexible, Efficient Transportation Equity Act: A Legacy for Users (SAFETEA-LU)," was enacted in August 2005. Section 10302 of the Act directed the agency "to

complete a rulemaking proceeding under chapter 301 of title 49, United States Code, to establish a standard designed to enhance passenger motor vehicle occupant protection, in all seating positions, in side impact crashes." In accordance with § 10302, the side impact air bags installed in front seats and vehicle changes made to rear seats will enhance, substantially, passenger motor vehicle occupant protection in side impacts.

DATES: *Effective date:* The date on which this final rule amends the CFR is November 13, 2007.

Petition date: If you wish to petition for reconsideration of this rule, your petition must be received by October 26, 2007.

Compliance dates: This final rule adopts a four-year phase-in of the new test requirements. The phase-in begins on September 1, 2009. By September 1, 2012, all vehicles must meet the upgraded pole and barrier test requirements of the standard, with certain exceptions. Alterers, manufacturers of vehicles produced in more than one stage, and manufacturers of vehicles with a gross vehicle weight rating greater than 3,855 kilograms (kg) (8,500 pounds (lb)) have until September 1, 2013 to meet the upgraded pole and barrier test requirements. Manufacturers can earn credits toward meeting the applicable phase-in percentages by producing compliant vehicles ahead of schedule, beginning November 13, 2007 and ending at the conclusion of the phase-in.

ADDRESSES: If you wish to petition for reconsideration of this rule, you should refer in your petition to the docket number of this document and submit your petition to: Administrator, National Highway Traffic Safety Administration, 1200 New Jersey Avenue, SE., West Building, Washington, DC 20590.

The petition will be placed in the docket. Anyone is able to search the electronic form of all documents received into any of our dockets by the name of the individual submitting the comment (or signing the comment, if submitted on behalf of an association, business, labor union, etc.). You may review DOT's complete Privacy Act Statement in the **Federal Register** published on April 11, 2000 (Volume 65, Number 70; Pages 19477-78) or you may visit <http://dms.dot.gov>.

FOR FURTHER INFORMATION CONTACT: For non-legal issues, you may call Christopher J. Wiacek, NHTSA Office of Crashworthiness Standards, telephone 202-366-4801. For legal issues, you may call Deirdre R. Fujita, NHTSA

Office of Chief Counsel, telephone 202-366-2992. You may send mail to these officials at the National Highway Traffic Safety Administration, 1200 New Jersey Avenue, SE., West Building, Washington, DC 20590.

SUPPLEMENTARY INFORMATION:**Table of Contents**

- I. Executive Summary
 - a. Final Rule
 - b. How the Final Rule Differs From the NPRM
 - c. Congressional Mandate
- II. Safety Need
- III. NPRM
 - a. Summary of Main Aspects of the Proposal Preceding This Final Rule
 - 1. Oblique Pole Test
 - 2. Moving Deformable Barrier (MDB) Test
 - 3. Lead Time
 - A. Oblique Pole Test
 - B. MDB Test
 - b. NPRMs on 49 CFR Part 572
 - c. Comment Periods Reopened Until April 12, 2005; Request for Comment
- IV. NHTSA 214 Fleet Testing Program
- V. Summary of Comments
- VI. Response to Comments
 - a. Critical Decisions
 - 1. 50th Percentile Male Dummy
 - A. We Are Denying the Alliance's WorldSID Petition
 - B. The Side Impact Dummy Can Be Upgraded Now to the ES-2re Without Further Delay
 - C. The ES-2re Is an Improvement Over the ES-2
 - D. The ES-2re Should Measure More Than HIC
 - 2. The 5th Percentile Female Dummy
 - A. The 5th Percentile Adult Female Dummy Is an Integral Part of This Upgrade
 - i. Need for the 5th Percentile Dummy in the Pole Test
 - ii. Need for the 5th Percentile Dummy in the MDB Test
 - iii. Beyond the Voluntary Commitment
 - B. However, Not All of the Proposed FRG Changes Are Needed
 - b. Aspects of the Pole Test Procedure
 - 1. Speed
 - 2. Angle
 - 3. Positioning the Seat for the Test
 - A. Fore-and-Aft Seating Position
 - B. Head Restraints
 - 4. Impact Reference Line
 - 5. Test Attitude
 - 6. Rear Seat Pole Test
 - 7. Door Closed
 - 8. FMVSS No. 201 Pole Test
 - 9. Quasi Static Test
 - 10. Vehicle Exclusions
 - 11. Practicability
 - 12. International Harmonization
 - c. Aspects of the MDB Test Procedure
 - 1. The Moving Deformable Barrier
 - 2. A Reasonable Balancing of the Test Burden
 - A. Arm Position
 - B. Reducing the Number of Tests
 - 3. Other
 - d. Injury Criteria
 - 1. Head Injury Criterion

- 2. Thorax (Chest) Criteria
 - A. ES-2re
 - i. Chest Deflection
 - ii. ES-2re Lower Spine Acceleration
 - B. SID-IIs Lower Spine Acceleration
 - 3. ES-2re Abdominal Criterion
 - 4. Pelvic Criterion
 - A. ES-2re
 - B. SID-IIs
 - e. Lead Time
 - 1. Pole Test
 - 2. MDB Test
 - f. Related Side Impact Programs
 - 1. Out-of-Position Testing
 - 2. Side NCAP
 - 3. Cross-References to FMVSS No. 214
 - g. Comments on the PEA

VII. Costs and Benefits

VIII. Rulemaking Analyses and Notices

IX. Appendices

I. Executive Summary

a. Final Rule

Federal Motor Vehicle Safety Standard (FMVSS) No. 214, "Side impact protection," currently provides thoracic and pelvic protection in a test using a moving deformable barrier to simulate being struck in the side by another vehicle. NHTSA is upgrading FMVSS No. 214 by requiring all passenger vehicles with a gross vehicle weight rating (GVWR) of 4,536 kg or less (10,000 lb or less) to protect front seat occupants in a vehicle-to-pole test simulating a vehicle crashing sideways into narrow fixed objects like utility poles and trees. By doing so it requires vehicle manufacturers to assure head and improved chest protection in side crashes for a wide range of occupant sizes and over a broad range of seating positions. It will ensure the installation of new technologies, such as side curtain air bags¹ and torso side air bags, which are capable of improving head and thorax protection to occupants of vehicles that crash into poles and trees and of vehicles that are laterally struck by a higher-riding vehicle. The side air bag systems installed to meet the requirements of this final rule will also reduce fatalities and injuries caused by partial ejections through side windows.²

This will be the first time that head injury criteria must be met under the

standard. In addition, thoracic, abdominal and pelvic protection in the FMVSS No. 214 crash tests must also be provided.

Vehicles will be tested with two new, scientifically advanced test dummies representing a wide range of occupants, from mid-size males to small females. A test dummy known as the ES-2re will represent mid-size adult male occupants. The ES-2re, a modified version of the European ES-2 side impact dummy, has improved biofidelity and enhanced injury assessment capability compared to all other mid-size adult male dummies used today. A test dummy known as the SID-IIs will represent smaller stature occupants. The SID-IIs is the size of a 5th percentile adult female. Crash data indicate that 34 percent of all serious and fatal injuries to near-side occupants in side impacts occurred to occupants 5 feet 4 inches (163 cm) or less, who are better represented by the 5th percentile dummy.³ (Specifications for the ES-2re and SID-IIs dummies have already been adopted into the agency's regulation for anthropomorphic test dummies, 49 CFR Part 572. For the ES-2re, the final rule was published December 14, 2006; 71 FR 75304 (NHTSA Docket 25441). For the SID-IIs, the final rule published December 14, 2006; 71 FR 75342 (Docket 25442).)

This final rule also enhances FMVSS No. 214's moving deformable barrier (MDB) test. In the test, the current 50th percentile male dummy in the front seat of tested vehicles will be replaced with the more biofidelic ES-2re. In the rear seat, the 5th percentile female SID-IIs dummy will be used, to enhance protection to a greater segment of occupants seated in rear seating positions. The 50th percentile male dummy and the 5th percentile female dummy together better represent the at-risk population than one dummy alone. Through use of both test dummies, vehicles must provide head, enhanced thoracic and pelvic protection to occupants ranging from mid-size males to small occupants in vehicle-to-vehicle side crashes.

We estimate that this final rule will prevent 311 fatalities and 361 serious injuries a year⁴ when fully implemented throughout the light

vehicle fleet. Countermeasures that not only reduce head injuries, but that also help reduce partial ejections through side windows, can save additional lives. The cost of the most likely potential countermeasure—a 2-sensor per vehicle window curtain and separate thorax side air bag system—compared to no side air bags is estimated to be \$243 per vehicle. After analyzing the data voluntarily submitted by manufacturers on their planned installation of side air bag systems, we estimate this final rule will increase the average vehicle cost by \$33⁵ and increase total annual costs for the fleet by \$560 million. We provide sufficient lead time to ensure that compliance is practicable.

The agency's data show that the majority of side air bag systems are currently equipped with two side impact sensors. If the market share of the two-sensor and four-sensor systems remains unchanged, the incremental cost for the most likely air bag system (curtain and thorax bag two-sensor countermeasure) would be about \$620 million, or \$37 per vehicle, assuming all light vehicles will be equipped with curtain air bags.

This final rule fulfills the mandate of the "Safe, Accountable, Flexible, Efficient Transportation Equity Act: A Legacy for Users," which was signed by President George W. Bush in August 2005. Evidently aware of the agency's pending notice of proposed rulemaking to upgrade FMVSS No. 214, Section 10302 of the Act directed the agency "to complete a rulemaking proceeding under chapter 301 of title 49, United States Code, to establish a standard designed to enhance passenger motor vehicle occupant protection, in all seating positions, in side impact crashes."

State of the Art

The state of knowledge and practicability of measures that can be taken to improve side impact protection are considerably greater than they were just a decade ago. Extensive work by those involved in the design, manufacture and evaluation of vehicle safety systems have led to substantial progress in crash test dummies, injury criteria and countermeasures used to mitigate side impacts. Inflatable side impact air bags (SIABs) have become

¹ These different side air bag systems are described in a glossary in Appendix A to this preamble.

² Improving side impact protection and reducing the risk of ejection are prominent in the National Highway Traffic Safety Administration's strategies to improve occupant protection. Further requirements to mitigate ejection are being developed by the agency to fulfill Sec. 10301 of SAFETEA-LU, which amended the National Highway and Motor Vehicle Safety Act (49 U.S.C. Chapter 301) to require the Secretary to issue by October 1, 2009 an ejection mitigation final rule reducing complete and partial ejections of occupants from outboard seating positions (49 U.S.C. 30128(c)(1)).

³ Samaha R. S., Elliott D. S., "NHTSA Side Impact Research: Motivation for Upgraded Test Procedures," 18th International Technical Conference on the Enhanced Safety Of Vehicles Conference (ESV), Paper No. 492, 2003.

⁴ Benefits and costs are estimated assuming 100 percent installation of Electronic Stability Control (ESC) systems in vehicles, and are based on manufacturers' current and planned installation of side air bags.

⁵ There are a wide variety of baseline side air bag systems planned for MY 2011. Some of these systems meet the final rule requirements, while manufacturers need to incorporate wider side air bags in others or add wide thorax side air bags or window curtains. The \$33 incremental cost estimate is a weighted average of the costs to bring all these different baseline conditions into compliance with the final rule.

available in current production vehicles. They vary widely in designs, sizes, mounting locations, methods of inflation and areas of coverage. For example, side impact protection systems include door-mounted thorax bags, seat-mounted thorax bags, seat-mounted head/thorax bags, and head protection systems that deploy from the roof rails (e.g., inflatable curtains, and inflatable tubular structures).

While varied in design, SIABs make possible vast improvements in head and torso protection that can be provided in side impacts. Head injuries alone account for 41 percent of the total deaths in the target population addressed by this final rule. For smaller-stature occupants, head injury represents a higher proportion of the serious injuries than it does for larger occupants, as a result of relatively more head contacts with the striking vehicle.⁶ NHTSA estimates that SIABs reduce fatality risk for nearside occupants by an estimated 24 percent; torso bags alone, by 14 percent.⁷

These remarkable improvements can accrue at reasonable costs. Vehicle manufacturers are already installing SIABs in some of their new vehicles. On December 4, 2003, the Alliance of Automobile Manufacturers, the Association of International Automobile Manufacturers (AIAM), and the Insurance Institute for Highway Safety (IIHS) announced a new voluntary commitment to enhance occupant protection in front-to-side and front-to-front crashes. The industry initiative consisted of improvements and research made in several phases, focusing, among other things, on accelerating the installation of SIABs.⁸

⁶ Samaha, *supra*.

⁷ Final Regulatory Impact Analysis, "FMVSS No. 214; Amending side impact dynamic test; Adding oblique pole test." Braver and Kyrchenko (2003) estimated that torso bags plus head protection reduced drivers' fatality risk in nearside impacts by 45 percent relative to drivers in cars without SIABs. Braver and Kyrchenko, "Efficacy of Side Airbags in Reducing Driver Deaths in Driver-Side Collisions," IIHS Status Report, Vol. 38, August 26, 2003. That study was based on fewer crash data than those used by NHTSA in its 2005 analysis.

⁸ See Docket NHTSA-2003-14623-13. Alliance and AIAM members agreed to this voluntary commitment. Under Phase 1 of the voluntary commitment, manufacturers have agreed that, not later than September 1, 2007, at least 50 percent of each manufacturer's new passenger car and light truck (GVWR up to 3,855 kg (8,500 lb) production intended for sale in the U.S. will be designed in accordance with either of the following head protection alternatives: (a) HIC₃₆ performance of 1000 or less for a SID-H3 crash dummy in the driver's seating position in an FMVSS No. 201 pole impact test, or (b) HIC₁₅ performance of 779 or less (with no direct head contact with the barrier) for a SID-IIs crash dummy in the driver's seating position in the IIHS MDB perpendicular side impact test. HIC₃₆ means the calculation of HIC is

Through voluntary efforts, manufacturers are able to begin equipping vehicles with advanced technologies and are able to advance safety more quickly than through the regulatory process. In formulating this regulation, we have been mindful to remain consistent with the technological advances upon which the industry's voluntary commitment were based, so as not to discourage further implementation while manufacturers develop designs and technologies that are able to comply with this regulation. This regulation builds on the same technologies that will be used by the industry to meet its voluntary commitment, and takes them even further.

The industry's voluntary commitment demonstrated the feasibility of SIABs as a fleet-wide countermeasure and ushered in a new stage in the regulatory, research and technological developments relating to side impact protection.⁹ This final rule broadens and fortifies this stage. Establishing these requirements as an FMVSS assures enhanced protection to all purchasers of vehicles, from those buying the most economical cars to purchasers of luxury trucks, to consumers in between. Together, the near term voluntary commitment and this final rule will achieve unprecedented side impact protection benefits.

b. How the Final Rule Differs From the NPRM

The noteworthy changes from the NPRM are outlined below and explained in detail later in this preamble. More minor changes (e.g., arm position of the dummies for the MDB tests, procedures for determining vehicle test attitude for the MDB test) are discussed in the appropriate sections of this preamble.

A. The agency proposed to use a SID-IIs Build C small female test dummy to

limited to a maximum time interval of 36 milliseconds. HIC₁₅ refers to a HIC calculating using a maximum time interval of 15 milliseconds. In Phase 2, not later than September 1, 2009, 100 percent of each manufacturer's new passenger car and light truck (GVWR up to 3,855 kg) (8,500 lb) production will be designed in accordance with the IIHS MDB recommended practice of HIC₁₅ performance of 779 or less for a SID-IIs crash dummy in the driver's seating position. The voluntary commitment provides exclusions for vehicles "that a manufacturer determines, due to basic practicability and functionality reasons, cannot meet the performance criteria, and would have to be eliminated from the market if compliance were required." (Alliance comment to Docket 17694, page 4, April 12, 2005.)

⁹ Section IV of the May 17, 2004 NPRM discusses the regulatory, research and technological developments related to FMVSS No. 214, from 1990 to the present. 69 FR at 27993.

which the agency had added "floating rib guide" (FRG) components to increase the durability of the dummy. The dummy with the FRG modification was called the "SID-IIsFRG." Comments to the NPRM maintained that the entirety of the FRG modifications was unnecessary, and that the totality of the FRG modifications needlessly reduced the biofidelity and functionality of the dummy. Some commenters suggested alternative means of improving the durability of the Build Level C dummy. After reviewing the comments to the NPRM and available test data, including the performance of the SID-IIs dummy in vehicle tests conducted with 2004-2005 model year (MY) vehicles¹⁰ [hereinafter "214 fleet testing program"], we have decided to adopt some, but not all, of the FRG modifications, and to adopt the commenters' alternative suggested revisions to Build Level C. The SID-IIs dummy adopted today into FMVSS No. 214 is referred to as the SID-IIs "Build Level D" crash test dummy.¹¹ Build Level D incorporates features stemming from the FRG and from users' efforts to enhance the functionality of predecessor SID-IIs dummies.

B. Mindful of the magnitude of this rulemaking and the principles for regulatory decisionmaking set forth in Executive Order 12866, Regulatory Planning and Review, NHTSA examined the benefits and costs of this rulemaking and, based on that analysis, took steps to reduce unnecessary test burdens associated with this final rule. After reviewing the comments to the NPRM and available test data, including MDB testing conducted in the NHTSA 214 fleet testing program, we have decided to require one MDB test per side of the vehicle. The MDB test specifies use of an ES-2re (50th percentile adult male) dummy in the front seating position and a SID-IIs (5th percentile adult female) dummy in the rear. Virtually all vehicles tested in the 214 fleet testing program met the MDB requirements when tested with SID-IIs in the front seat and the ES-2re dummy in the rear. Accordingly, we concluded that no additional benefits would accrue from an MDB test with the dummies so configured.

C. After reviewing the comments to the NPRM, the results of the 214 fleet

¹⁰ See Section IV of this preamble; also NHTSA's technical report of the test program, "NHTSA Fleet Testing for FMVSS No. 214 Upgrade MY 2004-2005," April 2006, Docket 25441-11 (25441 is the docket for the ES-2re test dummy final rule); and memorandum regarding location of the test date, December 6, 2006, Docket 25441-9.

¹¹ Docket 25442; final rule adopting SID-IIs Build Level D dummy into 49 CFR Part 572.

testing program and production plans which show installation of side air bags in vehicles ahead of the proposed schedule, we have determined that it would be practicable to provide a two-year lead time instead of the four-year lead time proposed in the NPRM leading up to the beginning of the phased-in pole test requirements. Compared to the original schedule, this would accelerate the benefits expected to be provided by side air bag systems and other countermeasures by phasing-in the requirements starting with 20 percent of model year (MY) 2010 vehicles. As explained in the FRIA, the phase-in schedule and percentages of this final rule facilitate the installation of side impact air bags and other safety countermeasures in light vehicles as quickly as possible, while the allowance of advanced credits provides manufacturers a way of allocating their resources in an efficient manner to meet the schedule. At the same time, we are also adding a fourth year to the proposed 3-year phase-in period and are making other adjustments to the schedule for heavier vehicles, to enhance the practicability of meeting the new requirements and provide additional flexibility to manufacturers to meet the requirements. Accordingly, under the phase-in schedule adopted in this final rule, the following percentages of each manufacturer's vehicles will be required to meet the new requirements:

- 20 percent of "light" vehicles (gross vehicle weight rating (GVWR) less or equal to 3,855 kilograms (kg) (8,500 pounds) (lb) manufactured during the period from September 1, 2009 to August 31, 2010;
- 50 percent of light vehicles manufactured during the period from September 1, 2010 to August 31, 2011;
- 75 percent of light vehicles manufactured during the period from September 1, 2011 to August 31, 2012;
- 100 percent of light vehicles manufactured on or after September 1, 2012, including limited line and small volume vehicles;
- 100 percent of vehicles with a GVWR greater than 3,855 kg (8,500 lb) manufactured on or after September 1, 2013 and vehicles produced by alterers and multistage manufacturers.

In addition, vehicle manufacturers will be able to earn credits for meeting the requirements ahead of schedule.

We are providing more lead time to meet the pole test requirements to manufacturers of vehicles with a GVWR greater than 3,855 kg (8,500 lb) because the vehicles have never been regulated under FMVSS No. 214's dynamic requirements and are not subject to the

industry's voluntary commitment to install side air bags. Because more redesign of the vehicle side structure, interior trim, and/or optimization of dynamically deploying head/side protection systems may be needed in these vehicles than in light vehicles, this final rule does not subject these vehicles to the pole test requirements until September 1, 2013.

D. We have decided to adopt a phase-in for the MDB test, and align the phase-in schedule with the oblique pole test requirements, with advance credits. In our test program, the SID-IIs in the rear seat of several vehicles measured elevated rib deflections and high pelvic loads that did not meet the injury criterion. This information indicated that structural and/or other changes to the rear seat of some vehicles are needed to provide improved chest and pelvic protection in the MDB test. An aligned phase-in will allow manufacturers to optimize engineering resources to design vehicles that meet the MDB and pole test requirements simultaneously, thus reducing costs. Manufacturers will also be able to use credits to more efficiently distribute their resources to meet the requirements.

E. For this final rule, the agency has re-examined the baseline fleet conditions projected to the compliance date of this final rule and has therefore adjusted the target population that would benefit from this rulemaking. In determining the target population for this final rule, the agency has assumed a 100 percent Electronic Stability Control (ESC) penetration in the model MY 2011 new vehicle fleet, and has further adjusted the estimated benefits of the rule by considering data from vehicle manufacturers on their planned installation of side air bags and on projected sales through model year MY 2011. Based on that information, the agency estimates that this rulemaking will save 311 fatalities and 361 serious injuries a year.¹² These values are lower than the NPRM's estimated benefits of 1,027 fatalities and 999 serious injuries saved annually, because the proposed estimates were based on the distribution of the different types of side air bag systems in the MY 2003 new vehicle fleet and did not assume 100% ESC penetration.

For this final rule, because the agency has used more extensive information, including manufacturers' planned installation of side air bags through MY 2011, the cost estimates of this final rule

¹² This estimates that window curtains, thorax side impact air bags, and two sensors per vehicle will be used.

are also lower than those of the NPRM. The average vehicle incremental cost of the curtain and thorax bag two-sensor countermeasure is estimated to increase the average vehicle cost by \$33, which is lower than the estimated NPRM cost of \$177 per vehicle.

c. Congressional Mandate

On August 10, 2005, President Bush signed the "Safe, Accountable, Flexible, Efficient Transportation Equity Act: A Legacy for Users," (SAFETEA-LU), Public Law 109-59 (Aug. 10, 2005; 119 Stat. 1144), to authorize funds for Federal-aid highways, highway safety programs, and transit programs, and for other purposes. Section 10302(a) of SAFETEA-LU provides:

Sec. 10302. Side-Impact Crash Protection Rulemaking

(a) Rulemaking.—The Secretary shall complete a rulemaking proceeding under chapter 301 of title 49, United States Code, to establish a standard designed to enhance passenger motor vehicle occupant protection, in all seating positions, in side impact crashes. The Secretary shall issue a final rule by July 1, 2008.

At the time of the enactment of § 10302(a), the agency's notice of proposed rulemaking to upgrade FMVSS No. 214 was pending. This final rule completes the rulemaking proceeding under consideration, and enhances the side impact protection of all the seating positions that the NPRM had proposed to upgrade.¹³ In this rulemaking, we considered several regulatory alternatives (see Chapter IX of the Final Regulatory Impact Analysis) and, consistent with Executive Order 12866, have maximized the benefits of those alternatives in the cost effective range.

We interpret SAFETEA-LU as providing us a fair amount of discretion. This regulation was initiated by NHTSA prior to enactment of SAFETEA-LU and we are required by the statute to complete it. We believe that SAFETEA-LU requires us to enhance the occupant protection of all seating positions under

¹³ Enhancing the protection of the seating positions under consideration in the NPRM addresses over 99% of the non-rollover side impact fatalities. In our analysis of vehicle sales, we found that 0 percent of passenger cars and 22 percent of light trucks have 3 or more rows of seats (minivans, some SUVs, and some full size vans). Assuming that passenger cars and light trucks each have 50 percent of all light vehicle sales, about 11 percent of all light vehicle sales will involve vehicles with 3 or more rows of seating. Looking at adult fatalities in side impacts in which non-rollovers were the primary event, there were 17 fatalities in the 3rd, 4th, or 5th rows. In comparison, in the same types of non-rollover side impacts, there were 8,570 adult fatalities in all rows. The 3+ row seats comprise 0.2 percent of the fatalities in that population (17/8,570 = 0.002).

consideration in the NPRM (front and rear outboard seating positions), without specifying the particular regulatory instruments or approaches that should be used to enhance occupant protection in those seating positions. SAFETEA-LU requires that this rulemaking be conducted in compliance with the National Traffic and Motor Vehicle Safety Act (49 U.S.C. 30101 *et seq.*), which includes the directive that our motor vehicle safety standards “shall be practicable, meet the need for motor vehicle safety, and be stated in objective terms” (49 U.S.C. 30111(a)). Thus, in responding to the comments to the NPRM (see section VI of this preamble), we must ensure that the upgraded FMVSS No. 214 final rule meets the criteria of Section 30111 (that it is practicable, that it meets the need for safety, and that it is stated in objective terms), while meeting the instruction of SAFETEA-LU that the final rule enhance occupant side impact protection in the seating positions under consideration in the NPRM.

This final rule enhances side impact protection in the front seating positions by requiring manufacturers to provide head protection in side impacts for the first time in the Federal safety standards. Due to the biofidelity of the current side impact dummy (SID) head and neck, the agency had determined that it was not appropriate to assess head injury with that dummy.¹⁴ This final rule adopts into FMVSS No. 214 two technologically advanced test dummies that have superior injury risk measurement capabilities compared to the SID, including the ability to assess the likelihood of head injury. The two test dummies represent occupants of different sizes: One represents an occupant of the size of a 5th percentile adult female, the other a mid-size (50th percentile) adult male. Use of both dummies in FMVSS No. 214 assures

that occupant protection in side impacts is afforded across a wide range of occupant sizes. Further, this final rule adopts a dynamic pole test into FMVSS No. 214, specifying performance requirements that vehicles must meet when tested with the test dummies. Adoption of the pole test will result in the installation of new technologies, such as side curtain air bags and torso side air bags, which are capable of improving protection to an occupant’s head, thorax, abdomen and pelvis. The use of the two crash test dummies in the pole test will require manufacturers to assure whole-body protection of front seat occupants, from small stature females sitting as close as they can to the steering wheel, to mid-size males sitting mid-track.

The final rule also enhances front seat occupant protection by specifying use of the new mid-size male dummy in the standard’s MDB test, which simulates a vehicle-to-vehicle crash. With its highly developed instrumentation and ability to assess rib deflections, the ES-2re will more thoroughly evaluate the degree to which manufacturers have designed vehicles’ front seats to protect occupants in vehicle-to-vehicle side crashes.

This final rule enhances occupant crash protection in rear seats as well. For the first time in the Federal motor vehicle safety standards, a limit is adopted on the risk of head injury for rear seat occupants. In addition, this final rule specifies the use of the 5th percentile adult female test dummy in testing rear seats in the MDB test of FMVSS No. 214. This change will enable NHTSA to assess better the ability of the rear seat environment to protect children, the elderly and small adults—a more vulnerable population than the mid-size adult male population—in vehicle-to-vehicle crashes. The dummy is more representative of rear seat occupants than the SID. Further, the injury

assessment reference values we will use with the dummy are set at levels that reflect the effect of aging on tolerance.

II. Safety Need

In the 2004 Fatality Analysis Reporting System (FARS), there were 9,270 side impact fatalities. For our target population, as described in the Final Regulatory Impact Analysis (FRIA) for this final rule, we excluded from these side impact fatalities those cases which were not relevant to the oblique pole and/or MDB crash conditions of this final rule. This left us with a target population of 2,311 fatalities and 5,891 non-fatal serious to critical MAIS 3–5 injuries for near-side occupants. The 2,311 fatalities were divided into two groups for the analysis: (1) Vehicle to pole impacts; and (2) vehicle-to-vehicle or other roadside objects impacts, which include partial ejections in these cases.¹⁵

In this target population, 41 percent of the total fatalities are caused by head/face injuries, 34 percent by chest injuries and 6 percent by abdominal injuries. In contrast, for the 5,891 non-fatal MAIS 3–5 target population, chest injuries are the predominate and maximum injury source, accounting for 48 percent. Head/face injuries account for 20 percent, and abdominal injuries account for two percent. Combining all serious to fatal injuries, chest injuries account for 49 percent, head/face injuries account for 26 percent, and abdominal injuries account for three percent.

For these two groups, we made an adjustment for estimated benefits that would result from the installation of Electronic Stability Control (ESC) systems in vehicles, based on an assumption that model year 2011 vehicles would be equipped with ESC.¹⁶ The ESC adjustment is shown below in Table 1:

TABLE 1.—TARGET POPULATION ADJUSTED WITH ESC
[Fatalities and MAIS 3+ for occupants, Delta-V Range of 12–25 mph]

Crash mode	MAIS 3	MAIS 4	MAIS 5	Fatal
Veh-to-Pole	368	210	72	219
Veh-to-Veh/others	3,713	903	177	1,823
Total	4,081	1,113	249	2,042

¹⁴ Report to Congress, “Status of NHTSA Plan for Side Impact Regulation Harmonization and Upgrade,” March 1999, Docket NHTSA–98–3935–10.

¹⁵ The agency’s analysis also found some fatality benefits for far-side unbelted occupants. In 2004

FARS, there were 1,441 unbelted far-side occupant fatalities in side impacts.

¹⁶ Manufacturers’ product plans submitted to the agency indicated that 71 percent of the MY 2011 light vehicles will be equipped with ESC. For the purposes of estimating benefits for today’s final rule, we have assumed that more vehicles will be

ESC-equipped, in part because the final rule on electronic stability control systems requires all MY 2012 vehicles to have ESC (Docket 27662). Accordingly, to estimate benefits for this FMVSS No. 214 final rule, we have assumed 100 percent of the MY 2011 light vehicles will have ESC.

We also made an adjustment based on the estimated benefits that would result from the FMVSS No. 201 upper interior requirements for the A-pillar, B-pillar,

and roof side rail.¹⁷ For the head, chest, abdomen and pelvis injuries, the fatalities for each crash mode, as adjusted for the effects of ESC and

FMVSS No. 201, are shown below in Table 2:

TABLE 2.—FATALITIES ADJUSTED, FRONT OCCUPANTS WITH ESC AND FMVSS NO. 201 HEAD, CHEST, ABDOMEN AND PELVIS

Crash mode	Head	Chest	Abdomen	Pelvis	Total
Veh-to-Pole	142	27	0	0	169
Veh-to-Veh/others	493	689	137	63	1,382
Total	635	716	137	63	1,551

III. NPRM

a. Summary of Main Aspects of the Proposal Preceding This Final Rule

NHTSA published the NPRM for this FMVSS No. 214 final rule on May 17, 2004 (69 FR 27990, Docket No. 17694). The NPRM provided a 150-day comment period on the proposal. The 150-day period closed October 14, 2004.

1. Oblique Pole Test

The NPRM proposed a pole test for FMVSS No. 214, and proposed to apply it to all passenger vehicles with a GVWR of 4,536 kg (10,000 lb) or less. The vehicle-to-pole test is similar to but more demanding than the one currently used optionally in FMVSS No. 201. The proposal was to propel a vehicle sideways into a rigid pole at an angle of 75 degrees rather than the 90-degree angle used in FMVSS No. 201.¹⁸ (We refer to the test using the 75-degree impact angle as the “oblique pole test.”) The test speed was proposed as any speed up to 32 km/h (20 mph)¹⁹ rather than the maximum test speed of FMVSS No. 201’s optional pole test (29 km/h (18 mph)). The 75-degree angle of impact and 32 km/h test speed made the pole test more representative than the FMVSS No. 201 test of real world side crashes into narrow objects.²⁰ Crashes

with a delta-V of 32 km/h (20 mph) or higher result in approximately half of the seriously injured occupants in narrow object near-side crashes.

The NPRM proposed using the ES–2re (50th percentile adult male) test dummy, and the SID–IIs (5th percentile adult female) test dummy as modified by the addition of floating rib guide (FRG) modifications.

The ES–2re is technically superior to both the SID–H3 50th percentile male test dummy currently used in the optional pole test of FMVSS No. 201 and the SID dummy now used in the MDB test of FMVSS No. 214. NHTSA proposed injury criteria for the ES–2re’s injury measuring instrumentation of the dummy’s head, thorax, abdomen and pelvis. HIC was to be limited to 1,000 measured in a 36 millisecond time interval (HIC₃₆). Chest deflection could not be greater than 42 mm (1.65 in) for any rib. Resultant lower spine acceleration could not be greater than 82 g. Abdominal loads could not exceed 2,500 Newtons (N) (562 lb). For pelvic injury, the NPRM proposed to limit pubic symphysis force to 6,000 N (1,349 lb).

The SID–IIs test dummy was developed by the Occupant Safety Research Partnership (OSRP), a research

group under the umbrella of the U.S. Council for Automotive Research (USCAR).²¹ NHTSA proposed to modify the dummy by adding the FRG modifications (the modified dummy is referred to as the SID–IIsFRG). Injury criteria for the SID–IIsFRG’s head, thorax, and pelvis were proposed. HIC₃₆ was to be limited to 1,000. For thoracic injury, the agency proposed a limit of 82 g on the resultant lower spine acceleration. A pelvic injury criterion of the sum of the iliac and acetabular forces measured on the dummy was proposed at 5,100 N. A limitation on rib deflection was not proposed because NHTSA wanted to obtain more information on the SID–IIsFRG’s rib deflection measurement capability and the deflection criteria that would be appropriate to apply to the dummy. For the same reasons, an abdominal injury criterion for the dummy was not proposed.

The NPRM presented test data from full scale oblique pole tests using a mid-size male dummy, and a small female dummy, to indicate the performance of vehicles in providing occupant protection in these side impacts. (These data are presented in Table 1 of Appendix C to this final rule.) As discussed in the NPRM, there were nine

¹⁷ In 1995, NHTSA issued a final rule amending FMVSS No. 201, “Occupant protection in interior impact,” to require passenger cars, and trucks, buses and multipurpose passenger vehicles with a gross vehicle weight rating of 4,536 kg (10,000 lb) or less, to provide protection when an occupant’s head strikes certain upper interior components, including pillars, side rails, headers, and the roof, during a crash. The amendments added procedures and performance requirements for a new in-vehicle test, which were phased in beginning in model year 1999.

¹⁸ FMVSS No. 201 employs an optional pole test to permit the installation of dynamically deploying upper interior head protection systems. This test was part of a set of amendments adopted in 1998 to permit, but not require, the installation of dynamically deploying upper interior head protection systems that were then under development (63 FR 41451; August 4, 1998). In the optional crash test, the vehicle is propelled at a speed between 24 km/h (15 mph) and 29 km/h (18 mph) into a rigid pole at an angle of 90 degrees. The

pole test injury criterion is HIC of 1000. The May 17, 2004 NPRM requested comment on adopting the FMVSS No. 201 pole test instead of the oblique pole test that was the preferred agency approach at the NPRM stage.

¹⁹ While 20 mph converts to 32.2 km/h, we are rounding 32.2 km/h to 32 km/h.

²⁰ When testing the driver side of the vehicle, an impact reference line is drawn on the vehicle’s exterior where it intersects with a vertical plane passing through the head CG of the seated driver dummy at an angle of 75 degrees from the vehicle’s longitudinal centerline measured counterclockwise from the vehicle’s positive X axis (see S10.14 of the regulatory text set forth in today’s document). When testing the front passenger side, the impact reference line would be drawn where it intersects with a vertical plane passing through the head CG of the passenger dummy seated in the front outboard designated seating position at an angle of 285 degrees from the vehicle’s longitudinal centerline measured counterclockwise from the vehicle’s positive X axis as defined in S10.14 of

today’s regulatory text. The vehicle is aligned so that, when the pole contacts the vehicle, the vertical center line of the pole surface as projected on the pole’s surface, in the direction of the vehicle motion, is within a surface area on the vehicle exterior bounded by two vertical planes in the direction of the vehicle motion and 38 mm (1.5 inches) forward and aft of the impact reference line. The test vehicle would be propelled sideways into the pole. Its line of forward motion would form an angle of 75 degrees (or 285 degrees) (±3 degrees) in the left (or right) side impact measured from the vehicle’s positive X axis in the counterclockwise direction.

²¹ USCAR consists of DaimlerChrysler, Ford and General Motors. The SID–IIs is used by Transport Canada for research purposes, and by the Insurance Institute for Highway Safety (IIHS), a nonprofit group funded by insurers, in IIHS’s 48 km/h (30 mph) side crash test consumer information program.

tests using a mid-size male dummy. In four of the tests, the test dummy was positioned in the driver's seating position as specified in the FMVSS No. 214 MDB test procedure, i.e., the seat was positioned mid-track. The other tests were conducted with the seat positioned as specified in FMVSS No. 201.²² Among other things, the NPRM data showed that the vehicles with air curtain systems performed well in providing head protection to occupants of the size of a 50th percentile adult male. Data for the 2004 Honda Accord demonstrated the practicability of meeting all of the NPRM's proposed injury criteria for the pole test using the FMVSS No. 214 seating procedure with the ES-2re dummy.

As discussed in the NPRM, one of the tests of a combination head/chest air bag system illustrated how the impact angle of the pole test can influence the level of protection provided by a vehicle's side air bags. An oblique pole test of a 1999 Nissan Maxima with a head/chest side impact air bag resulted in a HIC score of 5,254. The HIC of the Maxima in a 90-degree FMVSS No. 201 pole test resulted in a HIC score of 130. In the NPRM, NHTSA stated its expectation that, to comply with the proposed oblique pole test requirements, manufacturers will likely install head protection systems extending sufficiently toward the A-pillar to protect the head in the 75-degree approach angle test. The agency also noted that a 32 km/h (20 mph) oblique pole test has at least 15 percent more kinetic energy than an FMVSS No. 201 90-degree pole test at 18 mph.²³

The NPRM also discussed the results of three full scale oblique pole tests using the small female dummy on a 2003 Camry with an air curtain and thorax bag, a 2000 Saab 9-5 with a combination bag, and a 2002 Ford Explorer (see Table 2 of Appendix C). The agency stated that in the NPRM that the HIC₃₆ values generally exceeded the 1,000 limit, and pelvic forces exceeded the proposed 5,100 N limit. In contrast, a 2003 Camry whose air curtain and thorax bags were remotely fired at 11

milliseconds (ms) produced a HIC₃₆ of 512, and a 4,580 N pelvic force on the dummy.

2. Moving Deformable Barrier (MDB) Test

The current MDB test uses a 50th percentile adult male test dummy that was developed in the 1980s, and does not use a 5th percentile female dummy in the test. The NPRM proposed replacing the 50th percentile male dummy used with the technically advanced, more biofidelic ES-2re, and adding to the test the small female test dummy. For the first time in the MDB test, a head injury criterion was proposed.

The NPRM presented test results from FMVSS No. 214 MDB tests of a 2001 Ford Focus and a 2002 Chevrolet Impala using an ES-2re dummy in the driver and rear passenger seating positions (the data are set forth in Appendix C). These vehicles did not have side air bags in either front or rear seating positions. The test data from the NPRM showed that the Focus met the proposed test requirements when tested with the ES-2re, while the Impala did not. The Impala failed to meet the 44 mm rib deflection criterion for the driver dummy (45.6 mm), and produced an abdominal force on the rear seat dummy of 4,409 N (proposed limit was between 2,400-2,800 N). An examination of the passenger compartment interior revealed a protruding armrest of the Impala that contacted the abdominal area of the dummy, causing the high force reading.

As discussed in the NPRM, tests of a 2001 Ford Focus and 2002 Chevrolet Impala using the SID-IIIFRG in the driver and rear passenger seating positions showed that the Focus almost fully complied with the proposed MDB test requirements. Only the pelvic force for the driver dummy was exceeded in the test, which was attributed to an intruding armrest. The Impala was able to meet all of the driver injury criteria but failed to meet the limits on lower spine acceleration and pelvic force for the SID-IIIs in the rear seat, due to an armrest design. As discussed in the NPRM, in an MDB test of a 2001 Buick Le Sabre equipped with a front seat thorax side air bag, the vehicle met all the proposed criteria for both the front and rear seat dummies.

3. Lead Time

A. Oblique Pole Test

The agency proposed a lead time thought to be sufficient to ensure that compliance would be practicable, while seeking to make sure that the benefits of

the rule can be realized as soon as practicable. The NPRM proposed to phase in the upgraded side impact pole test requirements. The agency proposed to phase in the new test requirement beginning approximately four years from the date of publication of a final rule. The phase-in was proposed to be over three years, in accordance with the following schedule:

20 percent of each manufacturer's light vehicles manufactured during the production year beginning four years after publication of a final rule;

50 percent of each manufacturer's light vehicles manufactured during the production year beginning five years after publication of a final rule;

All vehicles manufactured on or after a date six years after publication of a final rule.

NHTSA proposed to include provisions under which manufacturers can earn credits toward meeting the applicable phase-in percentages if they meet the new requirements ahead of schedule. Alternatives were also provided to address the special problems faced by manufacturers producing limited line vehicles and vehicles manufactured in more than one stage, and vehicle alterers. Reporting and recordkeeping requirements for manufacturers to administer conformance with the phase-in were also proposed.

B. MDB Test

NHTSA proposed that the upgraded MDB test would be effective approximately 4 years after publication of a final rule. The agency tentatively concluded that a phase-in was unnecessary because the requirements could be met by padding and simple redesigns of the armrest area. This contrasted with the agency's belief about the vehicle changes entailed by the oblique pole test. Comments were requested on whether a phase in for the MDB test was appropriate.

b. NPRMs on 49 CFR Part 572

The agency issued notices of proposed rulemaking to add the specifications and performance requirements for the ES-2re dummy and for the SID-IIIs dummy into the agency's regulation on anthropomorphic test devices (49 CFR part 572). The NPRM on the ES-2re dummy was published on September 15, 2004 (69 FR 55550; Docket 18864), and the NPRM on the SID-IIIs was published on December 8, 2004 (69 FR 70947, Docket 18865).

²² Under the FMVSS No. 201 seating procedure, the dummy's head is positioned such that the point at the intersection of the rear surface of its head and a horizontal line parallel to the longitudinal centerline of the vehicle passing through the head's center of gravity is at least 50 mm (2 in) forward of the front edge of the B-pillar. If needed, the seat back angle is adjusted, a maximum of 5 degrees, until the 50 mm (2 in) B-pillar clearance is achieved. If this is not sufficient to produce the desired clearance, the seat is moved forward to achieve that result.

²³ Test results using the FMVSS No. 201 pole test procedures were presented in the NPRM, 69 FR at 28008.

c. Comment Periods Reopened Until April 12, 2005; Request for Comment

On January 12, 2005, NHTSA reopened the comment period for the May 17, 2004 NPRM on FMVSS No. 214 and for the September 15, 2004 NPRM adding the ES-2re 50th percentile adult male dummy to 49 CFR Part 572 (70 FR 2105; Dockets 17694 and 18864). That action responded to a petition from the Alliance of Automobile Manufacturers that requested an additional 8 months to submit comments. NHTSA determined that a 90-day extension of time was sufficient and that an 8-month extension was unwarranted and contrary to the public interest. The January 2005 document also requested comments on an addendum to an initial regulatory flexibility analysis (IRFA) relating to the NPRM on the oblique pole test. The addendum to the IRFA discussed the economic impacts of the proposed rule on small vehicle manufacturers. The comment periods were reopened until April 12, 2005.

Later, the Alliance petitioned to extend the comment period for the December 8, 2004 NPRM on adding the SID-IIs 5th percentile female test dummy to 49 CFR Part 572, which was scheduled to close on March 8, 2005. NHTSA agreed to extend the comment period for that NPRM to April 12, 2005, to align the comment closing date for that NPRM with the comment closing dates for the NPRMs on FMVSS No. 214 and the ES-2re (70 FR 11189; March 8, 2005; Docket 18865).

IV. NHTSA 214 Fleet Testing Program

In 2005, the agency conducted a 214 fleet testing program, a series of side impact crash tests to obtain information on how current vehicles performed in the oblique pole and MDB tests with the SID-IIs and ES-2re test dummies, and, in turn, on how the dummies performed in the full vehicle crash tests. Fourteen vehicle models were tested. Thirteen models were evaluated in the pole test, 10 of these 13 were tested with both the

SID-IIs (5th percentile female) and the ES-2re (50th percentile male) test dummies. Three of the 13 were tested with just the ES-2re test dummy. Seven of the 13 were tested also to the MDB tests using the SID-IIs and the ES-2re test dummies. One vehicle model was tested only to an MDB test using the SID-IIs (5th percentile female) test dummy. (See Table 3, "Test Matrix.")

The agency selected vehicles that represented different vehicle classes comprising the current vehicle fleet. Six rated a "Good" or "Acceptable" score in IIHS's side impact consumer rating program,²⁴ three rated a "Poor," and all had head curtains or combination side impact air bags. Six of the vehicles had a combination of both a head curtain air bag and an additional torso air bag in the front seating positions. Four had only a head curtain air bag. Four vehicles had a seat-mounted head and torso combination air bag system, two of which were convertibles.

TABLE 3.—TEST MATRIX

Vehicles (model year 2005 unless noted)	Side air bag type: AC=air curtain; Comb=head/chest SIAB; Th=thorax or chest SIAB	Vehicle class/weight	Oblique pole		FMVSS No. 214 MDB	
			SID-IIs	ES-2rd	SID-IIs	ES-2re
Toyota Corolla	AC + Th	Light PC	√	√	√	√
VW Jetta	AC + Th	Compact PC	√	√	√	√
Saturn Ion	AC	Compact PC	√	√	√	√
Honda Accord*	AC + Th	Medium	√	√	√	√
Suzuki Forenza	Comb	Compact PC	√
Beetle Convertible	Comb	Medium	√
Saab 9-3 Convertible	Comb	Medium	√
Ford 500	AC + Th	Heavy PC	√	√	√	√
Toyota Sienna*	AC + Th	Minivan	√	√
Subaru Forester	Comb	Small sport utility vehicle (SUV) (certified PC) Curb wt=3143 lb (medium PC).	√	√	√	√
Honda CRV	AC + Th	Small SUV	√	√	√	√
Chevy Colorado (4x2 Ext. Cab)	AC	Small Pickup	√	√
Ford Expedition	AC	Large SUV	√	√
Dodge 2500 (Reg Cab)	AC	Large Pickup	√

* 2004 Vehicles.
** Vehicles were categorized by their curb weight.

Light passenger car (PC) = (907–1,133 kg) or (2,000–2,499 lb).
Compact PC = (1,134–1,360 kg) or (2,500–2,999 lb).
Medium PC = (1,361–1,587 kg) or (3,000–3,499 lb).
Heavy PC = (1,588 kg or more) or (3,500 lb or more).

A detailed summary of the results of the test program is set forth in NHTSA's technical report of the test program, "NHTSA Fleet Testing for FMVSS No. 214 Upgrade MY 2004–2005," April 2006, (Docket 25441, items 9 and 11). Key findings of the test program are highlighted below.

Oblique Pole Test With SID-IIs

As discussed in the test report, 10 of the vehicles in the matrix were tested with the SID-IIs dummy in the oblique pole test. The test results are presented in Table 4. Thoracic and abdominal rib deflections were monitored.

²⁴ IIHS's side impact consumer information program ranks vehicles based on performance when impacted perpendicularly by a moving barrier at about 30 mph. http://www.iihs.org/ratings/side_test_info.html.

TABLE 4.—OBLIQUE POLE TEST RESULTS—SID—IIS DUMMY

Driver	HIC36	Lower spine (Gs)	Pelvic force (N)	Thorax deflection (mm) (monitored)	Abdominal deflection (mm) (monitored)
Proposed Injury Assessment Reference Values (IARVs) ...	1000	82	** 5,525	38	45
Toyota Corolla	418	70	***	47	49
VW Jetta	478	54	7876	33	34
Saturn Ion	5203	110	5755	32	52
Honda Accord*	567	63	10848	31	30
Ford Five Hundred	1173	92	6542	37	57
Toyota Sienna*	2019	67	6956	46	58
Subaru Forester	160	55	4707	31	45
Honda CRV	531	68	4670	26	36
Chevy Colorado 4x2 ext cab	896	135	9387	31	59
Ford Expedition	5661	96	8249	35	53

* MY2004.

** See Section VI.d.4.B of this preamble for a discussion of why we increased the proposed 5,100 N requirement to 5,525 N.

*** No data.

Most of the tested vehicles will need some design improvements to be certified as meeting the injury criteria limits for HIC, lower spine acceleration and/or pelvic force adopted by this final rule. Some vehicles will need more redesign than others. Some vehicles produced HIC, lower spine acceleration and/or pelvic force values that were greater than the injury assessment reference values (IARVs) of this final rule, while others were within the values but were close to the margin. For purposes of evaluating the current performance of these tested vehicles in relation to the IARVs of this final rule, we identified “elevated” values to be those that were within 80 percent of an IARV. The Subaru Forester and Honda CRV were the only vehicles that were below the IARVs,²⁵ but even these vehicles had lower spine acceleration and/or pelvic loads that were elevated (in excess of 80 percent of the IARVs).

HIC (SID—IIs in the Pole Test)

Four of the 10 vehicles tested with the SID—IIs (40 percent) exceeded HIC 1000: the Saturn Ion, Ford Five Hundred, Toyota Sienna, and Ford Expedition.

The Saturn Ion, Ford Expedition, and the Toyota Sienna’s side curtain air bag deployed but the SID—IIs dummy’s head hit the front edge of the curtain’s front pocket or tethered portion of the curtain, which was not inflated so as to cushion the impact.

The Ford Five Hundred had a head curtain and a thorax bag. It appears from test film that the Ford Five Hundred’s sensor deployed the curtain at approximately 85 ms after time zero, while the dummy’s head hit the pole at the front edge of the curtain at approximately 60 ms after time zero.

The same four vehicles produced relatively good HIC scores with the ES–2re dummy in the oblique pole test.

Lower Spine Acceleration (SID—IIs in the Pole Test)

The lower spine acceleration readings were generally consistent with the SID—IIs’s rib deflections. Two of the 10 vehicle tests with the SID—IIs resulted in rib deflection measurements exceeding 38 mm for the thoracic rib (which corresponds to a 50 percent risk of AIS 3+ injury). Six out of 10 exceeded 45 mm for the abdominal rib (45 mm is used by IIHS in its consumer

information program). In all of these tests, the lower spine acceleration values were also elevated (exceeding 82 g or within 80 percent of 82 g (i.e., 66 g)). The 6 tests were of the: 2005 Toyota Corolla, 2005 Saturn Ion, 2005 Ford Five Hundred, 2004/05 Toyota Sienna, 2005 Chevy Colorado 4x2 extended cab, and the 2005 Ford Expedition.

Pelvic Force (SID—IIs in the Pole Test)

Seven of the 10 vehicles exceeded 5,525 N (one vehicle lost data completely). The Honda Accord and the Volkswagen (VW) Jetta exceeded 5,525 N, yet had relatively lower numbers for the other injury criteria.

Oblique Pole Test With ES–2re

Thirteen tests were performed with the ES–2re dummy in the driver’s seating position. Data from the tests are set forth in Table 5. The data were analyzed assuming a 44 mm limit on rib deflection and a 2,500 N limit for abdominal force. Four vehicles produced results that were less than all of the injury assessment reference values: the VW Jetta, VW Beetle convertible, Saab 9–3 convertible and the Honda Accord.

TABLE 5.—ES–2RE OBLIQUE POLE RESULTS

Driver	HIC 36	Thorax deflection (mm)	Abdominal force (N)	Pelvic force (N)	Lower spine (G’s) (monitored)
Proposed IARVs	1000	44	2500	6000	82
Toyota Corolla	473	50	1178	3041	65
VW Jetta	652	36	1663	3372	60
Saturn Ion	806	50	1494	1585	76
Honda Accord	446	31	1397	2463	52
VW Beetle Convertible	315	37	1018	3815	69
Saab 93 Convertible	254	40	841	2914	49
Ford 500	422	35	3020	2133	68

²⁵ The Toyota Corolla was also below the IARVs, for the data collected. However, the pelvic force

data were not available in the test. Like the Subaru

Forester and Honda CRV, the lower spine acceleration was elevated in the test.

TABLE 5.—ES-2RE OBLIQUE POLE RESULTS—Continued

Driver	HIC 36	Thorax deflection (mm)	Abdominal force (N)	Pelvic force (N)	Lower spine (G's) (monitored)
Toyota Sienna	667	47	1751	2127	60
Subaru Forester	2054	43	1377	2291	46
Honda CRV	639	50	929	903	53
Chevy Colorado 4x2 ext cab	785	46	2655	3373	90
Ford Expedition	689	26	6973	2575	75
Dodge Ram 2500 (GVWR 8800)*	5748	47	1846	**	86

* Air bag did not deploy.
 ** No data.

HIC (ES-2re in the Pole Test)

The tests showed that an effective inflatable head protection system can be successful in reducing HIC.

Most HIC values were less than HIC 1,000. An exception was the Subaru Forester, the test of which resulted in a HIC reading of 2,054. This vehicle had a head and thorax combination air bag that deployed from the vehicle's seat. In the test, the air bag was pushed rearward by the intruding B-pillar and door structure. As a result, the dummy's head hit the pole, causing the HIC of 2,054.

Another exception was the Dodge 2500, which is the only heavy duty pickup truck with optional side curtains. In the pole test, the curtain air bag did not deploy, causing the ES-2re dummy's head to hit the pole (HIC 5,748). In a retest using this vehicle model in which the air bags were remotely deployed, the HIC was 331.

Rib Deflection (ES-2re in the Pole Test)

Table 5 shows that six of the vehicles produced chest deflection values greater than 44 mm (the Toyota Corolla, Saturn Ion, Toyota Sienna, Honda CRV, Chevy Colorado extended cab pickup, and the Dodge 2500 truck). In another vehicle, the Subaru Forester, the ES-2re measured 43 mm of chest deflection. Out of those seven vehicles, three had curtains with thorax bags: the Toyota Corolla, Toyota Sienna and Honda CRV. The Forester had a combination head/thorax bag. The Ion, Chevy Colorado and Dodge 2500 had only a curtain.

Seven vehicles produced results that were under 44 mm (VW Jetta, Honda

Accord, VW Beetle convertible, Saab 9-3 convertible, the Ford Five Hundred, Subaru Forester, and the Ford Expedition). However, the chest deflection measures for five of these vehicles (VW Jetta, VW Beetle convertible, Saab 9-3 convertible, Ford Five Hundred, and the Subaru Forester) were between 35 and 44 mm (i.e., were within 80 percent of 44 mm). The VW Jetta, Honda Accord, and Ford Five Hundred had a curtain and torso bag. The VW Beetle and Saab 9-3, in addition to the Subaru Forester, had combo bags. The Ford Expedition had only a curtain.

Lower Spine Acceleration (ES-2re in the Pole Test)

The ES-2re's lower spine acceleration readings in the pole test were relatively consistent with the dummy's rib deflection readings.

In eleven of the vehicles that measured high rib deflections exceeding 44 mm or that were within 80 percent of 44 mm, 5 of these had lower spine acceleration values that were also elevated (exceeding 82 g or within 80 percent of 82 g). The 5 vehicles were the: Saturn Ion, VW Beetle, Ford Five Hundred, Chevy Colorado and the Dodge 2500. The Toyota Corolla had an elevated lower spine acceleration of 65 g. The lower spine acceleration of the ES-2re was elevated (75 g) in the test of the Ford Expedition when the dummy's rib deflection was low (26 mm). However, the lower spine could have been detecting the high abdominal force reading on the ES-2re in that test (6,973 N).

Abdominal Force (ES-2re in the Pole Test)

Three vehicles produced abdominal force readings that exceeded 2,500 N (the Ford Five Hundred, Chevy Colorado and the Ford Expedition). The Chevy Colorado and Ford Expedition did not have torso air bags.

MDB Tests With SID-IIs

We conducted eight FMVSS No. 214 MDB tests with the SID-IIs in both the driver's seating position and in the left rear occupant's seating position. Data from the tests are set forth in Table 6 (driver) and Table 7 (rear passenger).

The data show that all but three vehicles produced dummy measurements that were below the proposed IARVs for both the driver and rear occupant. The SID-IIs in the driver seat of the Saturn Ion test measured a 8,993 N pelvic force. The Saturn Ion was not equipped with a thoracic side bag. It appears from the test film that the dummy's pelvis impacted a rigid area at the front part of the Ion's armrest. The SID-IIs in the rear seat of the Honda Accord measured 6,917 N in pelvic force, and the SID-IIs in the rear seat of the Suzuki Forenza measured a 6,557 N pelvic force.

In tests of 4 of the vehicles with the SID-IIs in the rear, the monitored rib deflection measurements were high (over 38 mm for the thoracic rib and 45 mm for the abdominal rib), and in 2 vehicles they were within 80 percent of 38 mm or 45 mm.

TABLE 6.—MDB TEST RESULTS USING THE SID-IIS—DRIVER

Driver	HIC36	Lower spine (Gs)	Pelvic force (N)	Thorax deflection (mm) (monitored)	Abdominal deflection (mm) (monitored)
Proposed IARVs	1000	82	5525	38	45
Toyota Corolla	78	59	4655	17	26
VW Jetta	46	30	2639	12	18
Saturn Ion	189	53	8993	19	39
Suzuki Forenza	69	53	4948	27	27

TABLE 6.—MDB TEST RESULTS USING THE SID-IIIS—DRIVER—Continued

Driver	HIC36	Lower spine (Gs)	Pelvic force (N)	Thorax deflection (mm) (monitored)	Abdominal deflection (mm) (monitored)
Honda Accord*	104	50	4150	20	22
Ford 500	46	31	2140	16	25
Subaru Forrester	43	37	3066	11	11
Honda CRV	38	32	1350	16	8

* MY 2004.

TABLE 7.—MDB TEST RESULTS USING THE SID-IIIS—LEFT REAR PASSENGER

Passenger	HIC36	Lower spine (Gs)	Pelvic force (N)	Thorax deflections (mm) (monitored)	Abdominal deflections (mm) (monitored)
Proposed IARVs	1000	82	5525	38	45
Toyota Corolla	330	57	3182	35	33
VW Jetta	103	52	3026	49	43
Saturn Ion	220	73	3964	47	52
Suzuki Forenza	773	73	6557	41	46
Honda Accord*	298	57	6917	30	32
Ford 500	216	42	2925	45	46
Subaru Forrester	150	43	3572	24	26
Honda CRV	107	56	3149	37	40

* MY 2004.

MDB Test With ES-2re

We conducted seven FMVSS No. 214 MDB tests with the ES-2re in both the

driver's seating position and in the left rear occupant's seating position. The vehicle models were the same ones that were tested with the SID-IIIs in the MDB

tests, above. Data from the tests are set forth in Tables 8 and 9. The dummy responses were low relative to the IARVs.

TABLE 8.—ES-2RE MDB TEST RESULTS—DRIVER

Driver	HIC36	Thorax deflection (mm)	Abdominal force (N)	Pubic symph. force (N)	Lower spine (G's) (monitored)
Proposed IARVs	1000	44	2500	6000	82
Toyota Corolla	73	25	722	3223	40
VW Jetta	101	26	733	1969	28
Saturn Ion	110	29	1524	2431	52
Honda Accord	109	37	557	1983	38
Ford 500	66	25	1006	1176	35
Subaru Forrester	44	21	598	1694	33
Honda CRV	100	35	524	1137	31

TABLE 9.—ES-2RE MDB TEST RESULTS—REAR PASSENGER

Passenger	HIC36	Thorax deflection (mm)	Abdominal force (N)	Pubic symph. force (N)	Lower spine (G's) (monitored)
Proposed IARVs	1000	44	2500	6000	82
Toyota Corolla	248	20	1355	2771	58
VW Jetta	211	29	1378	2542	53
Saturn Ion	168	27	1511	2275	47
Honda Accord	223	23	810	2405	53
Ford 500	213	25	1649	1407	44
Subaru Forrester	226	23	967	1948	35
Honda CRV	126	5	1192	1847	33

General Observations

NHTSA has made the following general observations from the agency's 214 fleet testing program.

- Overall, currently installed side impact head protection systems (HPS) consisting of an air curtain or combination head/thorax air bag were

effective in mitigating head accelerations, resulting in low to moderate HIC readings for the ES-2re and SID-IIIs dummies in both MDB and

oblique pole tests. Vehicles equipped with well-designed combo bags, and air curtains that extend toward the A-pillar when inflated, generally were the better performers in the oblique pole tests.

- Some currently installed side impact HPS that provide relatively low head protection response values to the SID-IIs driver dummy in the MDB test do not necessarily provide the same low level head responses in the oblique pole test.

- In the oblique pole tests, vehicles that provided adequate protection for the ES-2re do not necessarily provide the same level of protection for the SID-IIs. The data show the importance of using more than one size test dummy to evaluate the overall performance of a vehicle in providing head protection to occupants in the oblique pole test mode.

- In oblique pole tests using the SID-IIs, most vehicles produced pelvic force readings above the proposed criterion. In the MDB tests with the SID-IIs seated in the driver's position, only one vehicle produced a pelvic force greater than 5,525 N. All other vehicles subjected to the MDB test with the SID-IIs seated in the driver's position had pelvic force readings below 5,525 N.

- The SID-IIs in the rear seats of vehicles subjected to the MDB test had elevated thoracic and/or abdominal rib deflections that were not observed in MDB tests of those same vehicles with the ES-2re in the rear seats.

- The results of oblique pole tests in which the air curtain did not deploy or deployed later in the event indicate needed air bag sensor improvement.

- The convertibles equipped with head/thorax combination air bags produced measurements that were below the proposed injury criteria, demonstrating the effectiveness and feasibility of these HPS for convertible body types.

- Some vehicles that received "Good" or "Acceptable" ratings from IIHS for the rear passenger exceeded proposed IARVs in our MDB tests using the SID-IIs.

- The vehicles that were tested with the ES-2re that produced dummy readings below the proposed IARVs in the pole and MDB tests were: 2004 Honda Accord, 2005 Volkswagen Jetta, 2005 Volkswagen Beetle Convertible, and the 2005 Saab 93 Convertible. The vehicles that were tested with the SID-IIs that produced readings below the proposed IARVs in the pole and MDB tests were: 2005 Toyota Corolla, 2005 Subaru Forester and the 2005 Honda CRV.

V. Summary of Comments

This section provides an overview of the significant comments to the proposal to upgrade FMVSS No. 214.

All together, NHTSA received 35 comments to the proposal to upgrade FMVSS No. 214.²⁶ Commenters included—

Vehicle manufacturers and/or vehicle manufacturer associations (the Alliance of Automobile Manufacturers (Alliance²⁷), American Honda Motor Co., Inc. (Honda), the Association of International Automobile Manufacturers, Inc. (AIAM²⁸), Nissan North America, Inc. (Nissan), Lotus Engineering (Lotus), Ferrari SpA (Ferrari), Maserati SpA (Maserati), the Recreation Vehicle Industry Association, Inc. (RVIA), Specialty Equipment Market Association (SEMA), the National Mobility Equipment Dealers Association (NMEDA) and the National Truck Equipment Association (NTEA));

Air bag equipment suppliers (Autoliv and TRW);

Research groups (IIHS), the International Harmonized Research Activities (IHRA) Side Impact Working Group (SIWG);

Consumer groups (Advocates for Highway and Auto Safety (Advocates), Public Citizen, and Consumers Union); And private individuals.

Overview of the Comments

The vehicle manufacturers supported enhancing side impact protection but had concerns about how the proposed rulemaking would comport with the initiatives they have already undertaken or agreed to undertake towards that goal (e.g., the "voluntary commitment" of major automakers in the U.S. to phase in side air bags for drivers in vehicles up to 3,855 kg (8,500 lb) GVWR). The vehicle manufacturers strongly supported the incorporation of WorldSID²⁹ into FMVSS No. 214,

²⁶ The NPRMs proposing to add the ES-2re and SID-IIs dummy specifications to 49 CFR part 572 each received comments separately from the FMVSS No. 214 NPRM. Those comments are addressed in full in final rules that were published separately from this document and are discussed here to the extent relevant to the FMVSS No. 214 final rule.

²⁷ The Alliance is made up of BMW group, DaimlerChrysler, Ford Motor Company, General Motors, Mazda, Mitsubishi Motors, Porsche, Toyota, and Volkswagen.

²⁸ AIAM Technical Affairs Committee members are: Aston Martin, Ferrari/Maserati, Honda, Hyundai, Isuzu, Kia, Nissan, Peugeot, Renault, Subaru, Suzuki, Bosch, Delphi, Denso, and Hitachi.

²⁹ WorldSID is considered by industry to be the next-generation 50th percentile male side impact dummy. It was developed by industry representatives from the U.S., Europe and Japan and by the European and Japanese governments (see

marked by the Alliance submitting, concurrently with its comment on the FMVSS No. 214 NPRM, a petition for rulemaking asking NHTSA to initiate rulemaking to incorporate WorldSID into Part 572 and to use the dummy in the upgrade of FMVSS No. 214 (NHTSA Docket 17252). The Alliance further suggested that, prior to use of WorldSID, the ES-2 dummy should be used (without the rib extensions), and only to the extent of protecting the head. The Alliance believed that there was no safety need for the 5th percentile SID-IIs adult female crash test dummy in the proposed pole and MDB tests. No commenter supported the floating rib guide modifications proposed by NHTSA for the SID-IIs dummy.

Air bag supplier Autoliv supported use of the ES-2re in tests and supported use of the 32 km/h (20 mph) test speed in the oblique pole test. Autoliv stated that NHTSA was correct in its belief that an oblique pole test will encourage larger bags than a perpendicular pole test. Air bag supplier TRW believed that adoption of the NPRM will result in substantial reductions in injuries and severity in side impacts. TRW stated that technology exists to meet the proposed requirements of the NPRM within the timeframe and that it saw no major issues with the proposed test conditions. TRW believed that systems designed to meet the proposed requirements could have acceptable performance in out-of-position situations.

Vehicle manufacturers raised issues or had questions about aspects of conducting the proposed test procedure for the oblique pole test. The Alliance supported the 75-degree angle of the test, but suggested that the test speed should be bounded at 26 km/h to 32 km/h (16 to 20 mph) (the NPRM proposed that the test would be conducted at any speed up to and including 32 km/h (20 mph)). Maserati and Ferrari supported the 90 degree 29 km/h (18 mph) pole test used in the European New Car Assessment Program (Euro NCAP). The IHRA SIWG expressed concern about the NPRM preempting the outcome of international deliberations of the SIWG regarding the side impact pole test procedure. Vehicle manufacturers also commented on technical aspects of the test procedure, such as how the vehicle seat should be positioned along the seat track, where on the pole the vehicle should impact;

Docket No. 2000-17252). This future dummy is believed by its developers to have better biofidelity than existing dummies, and is intended to better predict a wider range of injury potential in side impact testing than current dummies.

and how the test dummies and head restraints should be positioned.

Consumer groups generally supported the proposed rule, but suggested that the agency should adopt further requirements. Advocates, Consumers Union, and Public Citizen wanted more stringent injury criteria limits than those proposed (e.g., HIC of 800), and recommended extending the oblique pole test to rear seating positions.

Comments were also received on the types of vehicles that should be excluded from the pole test, and on the lead time needed to comply with the proposed oblique pole test and with the changes to the MDB test. Nissan submitted test data³⁰ of one small vehicle and two mid-size vehicles tested according to the proposed test procedures for the oblique pole test and MDB test. The commenter said that the data indicate that curtain air bags may be needed in some vehicles to meet the pole test requirements, and that some vehicles could need a full redesign of the door structure, including the modification or addition of air bags, to meet the MDB test requirements. Nissan requested that the MDB test requirements be phased-in along the same schedule that would be implemented for the pole test, and that both phase-ins be over a 4-year rather than 3-year period.

Comments were also received on NHTSA's Preliminary Economic Assessment (PEA), which analyzed the costs and benefits and other impacts of the proposed rule. Maserati and Ferrari believed that NHTSA underestimated their costs to comply with the proposed rule. The Alliance believed that: In estimating benefits, we should have identified as the target population all potentially injured occupants of relatively modern vehicles for whom the countermeasures are designed; that the proposed changes to the MDB test should have a benefits estimate; that we did not demonstrate the practicability of meeting the proposed test requirements, in that "no one single vehicle has been subjected to the entire suite of proposed crash tests"; and that the principles set forth in the Data Quality Act were not met (the commenter believed that some of the data in the PEA had errors and that the PEA contained some unsupported assumptions). The Specialty Equipment Market Association (SEMA) stated that "aftermarket equipment manufacturers and other entities that diagnose, service, repair and upgrade motor vehicles" may be affected by the final rule if their

installed products interact with equipment or systems used by vehicle manufacturers to meet the FMVSS No. 214 requirements.

In October 2006, to estimate the costs and benefits of the final rule, NHTSA sent letters asking vehicle manufacturers to submit voluntarily information on the installation of side air bags in present and future vehicles. Information was received from seven manufacturers, whose information related to about 90 percent of light vehicle sales.

VI. Response to the Comments

a. Critical Decisions

We made several critical decisions in our analysis of the comments. These decisions were critical in defining the safety problem, the test dummies that should be used to address the safety problem, and the crash tests that should be used to evaluate measures to ameliorate the safety problem. Specifically, these decisions pertained to:

Which test dummy should be used to represent the mid-size male;

Whether the standard should limit more than HIC; and

Whether FMVSS No. 214 should use a small female dummy in the pole and MDB tests.

These decisions are discussed in this section.

1. 50th Percentile Male Dummy

The Alliance, AIAM, IIHS, Honda, Maserati, Ferrari, Advocates, and Autoliv commented on the proposal to use the ES-2re test dummy to represent the mid-size male occupant. Generally, the vehicle manufacturers opposed the ES-2re, preferring instead the WorldSID. In its petition for rulemaking, the Alliance asked NHTSA to consider adopting the WorldSID into Part 572 and using the dummy in the phase-in of the pole test requirements.³¹ The Alliance stated that WorldSID would further enhance occupant protection and the international harmonization of safety standards.

However, other commenters acknowledged that WorldSID is not yet ready for use in a safety standard. IIHS said that while WorldSID might be more biofidelic than any other existing dummy, "developmental testing is not complete on the new, state-of-the-art dummy, and therefore the time is not ripe for its inclusion in rulemaking." IIHS did not believe that WorldSID was necessary in order for the agency to increase the requirements for protection

of the midsize male in side impacts. In this interim period while the WorldSID continues to be evaluated, IIHS supported the ES-2re over the SID and SID-H3 dummies because of the improved biofidelity of the ES-2re and the more sensitive information the ES-2re can provide on rib deflection characteristics and pelvic loading. Autoliv also supported the ES-2re's replacing the SID-H3 dummy, based on the improved biofidelity of the proposed dummy and the tendency toward closer harmonization with other global test requirements. "Using the same test dummy globally would allow manufacturers to focus on optimizing the air bag design to the performance requirements of the more biofidelic dummy."

A. We Are Denying the Alliance's WorldSID Petition

We are denying the Alliance's petition for rulemaking because the WorldSID is not ready for use in Federal regulations, nor has it been established that it has achieved a completed design allowing a full assessment of the dummy's potential use in FMVSS No. 214. The WorldSID committee has been modifying the dummy's design, including modifications to the dummy's ribs (June/July 2006), to address durability and other problems that NHTSA found during the agency's evaluation of the dummy.

NHTSA has been working with the WorldSID committee to evaluate the functionality of the dummy as a potential research and compliance test device. We undertook a three-phase program to evaluate the dummy's repeatability, durability and usefulness. The program consisted of: (a) Laboratory-based anthropometry, mass, instrumentation and extensive subsystem evaluations; (b) sled tests; and (c) vehicle crash tests. During phase (a) of the program (the subsystem evaluation), we observed cracking of rib damping material, which led to several modifications of the rib design by the WorldSID committee. The committee sent the revised ribs to NHTSA in August 2006 for evaluation in the agency test program. During evaluation of the rib modifications, concerns over the pelvis design arose when it was observed that the pelvis wing contacted on onboard data acquisition component mounted below the lumbar spine. The agency and the WorldSID committee are presently evaluating modifications to the pelvis design to eliminate this problem.

Once the pelvis modifications can be evaluated and the internal contact issue has been resolved, NHTSA will resume

³⁰ Submitted under a request for confidential treatment.

³¹ http://dmses.dot.gov/docimages/pdf91/325474_web.pdf

evaluation of the modifications to the ribs. However, because we cannot know at this point what the outcome of the evaluation will be and because we will not know the outcome for a considerable period of time, we are denying the Alliance's petition. If the evaluation indicates that the WorldSID design is complete, the agency will then consider whether rulemaking should be undertaken³² to possibly incorporate use of the dummy as a test device during the phase-in period of the requirements adopted today. In the meantime, advancements in occupant protection can be achieved today by upgrading the side impact dummy used in FMVSS No. 214 to the ES-2re, without waiting for a future test dummy.

B. The Side Impact Dummy Should Be Upgraded Now to the ES-2re Without Further Delay

The technology of the ES-2re represents a significant advance over the SID dummy. The ES-2re has enhanced injury assessment capabilities compared to devices existing today, which allows for a fuller assessment of the types and magnitudes of the injuries occurring in side impacts and of the efficacy of countermeasures in improving occupant protection. The ES-2re dummy has provisions for instrumentation that can assess the potential for head injury (it measures the resultant head acceleration, which is used to calculate the Head Injury Criterion (HIC)) and thoracic injuries in terms of rib deflections and spine and rib accelerations. Chest deflection has been shown to be the best predictor of thoracic injuries in low-speed side impact crashes. It is a better injury risk measure than TTI(d) (a chest acceleration-based criterion measured by SID). The ES-2re can also assess the risk of abdominal injuries through three load cells to assess the magnitude of lateral and oblique forces, and the risk of pubic symphysis injuries by way of load cell measurements, as well as pelvis acceleration.

The more advanced test dummy makes possible a more complete assessment of vehicle performance in side impacts, which, together with appropriate injury assessment criteria, will lead to greatly enhanced side impact protection for occupants. In an MDB test described in the May 2004 NPRM (69 FR at 28010), the ES-2re detected a high abdominal force in the

Chevrolet Impala at the dummy's abdominal area that was caused by an intruding armrest. Because the SID does not measure abdominal force, this potential injury risk will be newly detected by the ES-2re. Accordingly, this final rule adopts the ES-2re for the pole test and for testing the front seat of vehicles in FMVSS No. 214's MDB test.

C. The ES-2re Is an Improvement Over the ES-2

The Alliance supported the ES-2 as a temporary alternative test device, pending the availability of WorldSID. The Alliance supported the ES-2 because the dummy is already implemented in both EuroNCAP and the UN ECE-regulation 95.02 Supplement 1, i.e., "at least the ES-2 is harmonized with Europe and already in widespread use." The Alliance stated that OSRP gave the ES-2 a biofidelity rating of 4.6 and the ES-2re an overall rating of 4.3 using the ISO-based ranking. (In the ISO ranking system, a dummy with a higher value is considered more biofidelic than one with a lower value.)

The ES-2re is more appropriate for use in FMVSS No. 214 than the ES-2 dummy. As explained in the May 2004 NPRM and in the rulemaking incorporating the ES-2re into 49 CFR part 572,³³ the ES-2 dummy has a deficiency that limits its usefulness in FMVSS No. 214. The agency determined that, in a number of vehicle crash tests, the back plate of the ES-2's upper torso grabbed into the seat back of the vehicle, which lowered the rib deflections measured by the dummy. ("Design, Development, and Evaluation of the ES-2re Side Crash Test Dummy," May 2004, NHTSA Docket No. 17694-11.)

This "back plate grabbing" problem has long existed in the ES-2 line of dummies. Although efforts were undertaken to address the problem in dummies preceding the ES-2, the back plate grabbing problem has continued with the ES-2. Back plate grabbing has been seen within the ES-2 in the non-governmental European New Car Assessment Program (EuroNCAP) on side impact. EuroNCAP accounts for the problem by adjusting downward the consumer rating scores of vehicles when back plate grabbing is deemed to have occurred.

The ES-2re has rib extensions that solve the back plate grabbing problem of the ES-2. The rib extensions provide a continuous loading surface that nearly encircles the thorax and encloses the posterior gap of the ES-2 ribcage that

was responsible for the "grabbing" effects. Test data show that the rib extensions reduced the back plate grabbing force to insignificant amounts in vehicle side impact tests that had previously yielded large back plate loads with the ES-2. The rib extensions did not affect rib deflection responses in tests of vehicles that had not originally yielded high back plate loads.

The biofidelity, repeatability, reproducibility, and other aspects of the ES-2re are discussed at length in the agency's December 14, 2006 final rule adopting the ES-2re into 49 CFR part 572 (see Docket 25441). With regard to Toyota's and the Alliance's comment³⁴ that the rib extensions reduced the ISO-based biofidelity assessment of the ES-2 from 4.6 to 4.3, or from "fair" to "marginal," we conclude that the reduced ISO rating is an acceptable outcome of having the rib extensions. The back plate loading problem of the ES-2 renders the ES-2 non-lifelike. If the rib extensions reduce slightly the ISO biofidelity rating but enables NHTSA to use a dummy that has the measurement capabilities of the ES-2 and no back plate loading problem, we conclude that the lower rating is acceptable. We note that the ISO rating represents an improvement over the SID, which received a rating of 2.3 (Byrnes, *et al.*, "ES-2 Dummy Biomechanical Responses," 2002, Stapp Car Crash Journal, Vol. 46, #2002-22-0014, p. 353). The ES-2re biofidelity rating also compares favorably to that of the SID-H3, which received an overall rating of 3.8. Both the SID and SID-H3 have performed well in driving the installation of life-saving countermeasures that have substantially improved the safety of occupants in side impacts.³⁵

In short, we cannot accept the ES-2 test dummy because of the back plate loading problem. With the rib extensions of the ES-2re, the back plate loading problem is solved. The ES-2re will enhance levels of side impact protection provided by FMVSS No. 214. The enhancements will be seen in vehicles produced in the near term, regardless of the future assessment of WorldSID.

³⁴ The commenters neither provided reference to a published report nor provided supporting data related to the claim that the overall ISO score for the ES-2re is 4.3. The absence of foundation for the comment limits our ability to respond.

³⁵ The ES-2re also has improved injury assessment capability compared to the SID and SID-H3 mid-size male dummies. The ES-2re dummy will enhance the protection afforded by vehicles to the affecting population, especially those represented by a 50th percentile male dummy. Thus, this final rule adopts the ES-2re and not the SID or the SID-H3 dummies.

³² The suitability of WorldSID for use in FMVSS No. 214 and as a part 572 test device would ultimately be determined through notice-and-comment rulemaking, in accordance with statutory criteria.

³³ NPRM at 69 FR 55550, September 15, 2004, Docket 18864; final rule at 71 FR 75304, December 14, 2006, Docket 25441.

D. The ES-2re Should Measure More Than HIC

The Alliance suggested that the mid-size male dummy in the upgraded requirements of FMVSS No. 214 should measure only HIC. While supporting the ES-2 over the ES-2re, the Alliance stated that both test dummies have design features that affect the dummies' thoracic responses and the resulting rib deflection measurements. According to the commenter, the "limited stroke piston/cylinder mechanism" of the dummies can bind in a lateral impact, and the "binding potential is further compounded as the lateral impact becomes more oblique."

The Alliance also stated that both the ES-2 and ES-2re dummies incorporate a shoulder design that makes the kinematics of the dummy unlike that of a cadaver. The commenter stated that the human shoulder compresses inward and moves slightly rearward in impacts from the front or side, while the dummies' shoulders are designed to rotate forward, preventing the arm from interacting with intruding structures. The Alliance stated, "In full-scale vehicle tests, the WorldSID shoulder deflects laterally inward replicating a more human like response."

Additionally, the Alliance believed that the ES-2 and ES-2re dummies— are too narrow through the abdomen and pelvis and do not represent the anthropometry of either the U.S. or world populations. Also, in full-scale tests conducted by the OSRP, the ES-2 measured abdominal forces below the Injury Assessment Reference Values (IARV), while the WorldSID measured abdominal deflections above the IARV. This indicates that the ES-2 abdominal region is too narrow to properly interact with intruding vehicle structures and is inadequately instrumented, causing it to erroneously miss a potential risk of abdominal injury. The WorldSID can better assess the risk of abdominal injury because its anthropometry better matches that of the human population and it is equipped to measure abdominal deflection.

Because the Alliance believed there are deficiencies with the ES-2, the commenter said that NHTSA should just require manufacturers to meet a head protection criterion, and not criteria assessing injury to the thorax, abdomen or pelvis.

We are denying this request. Our analysis of the thoracic response of the ES-2re demonstrated that the dummy's thoracic responses provided valid data. We analyzed crash data from oblique and perpendicular pole tests of two vehicles: A 1999 Maxima and a 2001 Saturn. The vehicles were not equipped with side air bag systems. The rib deflections of the ES-2re in the driver's

seating position were almost identical in the oblique and perpendicular pole tests. The rib deflections of the dummies were consistent in time and were of similar magnitude. There was no indication of flat-topping, binding or distortion of the deflection signal due to oblique loading. In addition, T1 driver lateral acceleration was consistent and did not show differences between oblique and perpendicular impacts. (See "Lateral vs. Oblique Impacts of the ES-2 Dummy in Pole and MDB Tests," April 2006, a copy of which is in Docket 25441).

Both the lower spine accelerations (T12) and the summed abdominal forces for the driver ES-2re were higher in the oblique pole test configuration. However, the oblique pole test was run at a higher impact speed than the perpendicular test (20 mph versus 18 mph), which likely increased the measurements. Also, in the oblique pole test, the lower part of the dummy torso appears to be loaded earlier in the crash event than in a perpendicular test, which indicates that the T12 and abdominal forces could be higher because initial loading is more through the lower part of the torso.

We also analyzed the measurements of the ES-2re in FMVSS No. 214 MDB tests of a 2001 Ford Focus, 2002 Chevrolet Impala equipped with a combo head/thorax side air bag for the driver, and a 2004 Honda Accord equipped with a thorax bag. Overall, the driver rib deflections were higher than the deflections for the rear passenger dummy. However, a different loading environment caused the lower rib deflections for the ES-2re in the rear seat as compared to the driver. Rib deflections showed a slow rise, and the peaks occurred about 10 milliseconds later than those of the driver dummy. The loading duration was also considerably longer. The passenger rib deflections were consistently lower towards the bottom of the ribcage. *Id.*

For the Focus, the driver and passenger T12 accelerations were comparable. For the Impala and Accord, the rear passenger T12 acceleration was larger than that of the driver dummy. This difference could be attributed to the fact that both the Impala and Accord had a thorax side air bag for the driver position and none for the rear passenger position.

The data from the tests did not show a sensitivity to oblique loading in the dummy's abdomen. The passenger abdominal force for the Impala was very large compared to the driver abdominal force, but this was due primarily to large structural intrusions (the test film shows the arm rest intruding into the dummy

in the MDB test). This indicates a localized loading through the abdomen for the Impala passenger (resulting in an off-loading condition for the chest and, thus, much lower rib deflection measurements as compared to the driver dummy). For the Accord, the passenger abdominal force was larger than the driver abdominal force, but the difference could be attributed to the side air bag in the driver position.

The Alliance contended that the ES-2re's shoulder has a biomechanical flaw in that the shoulder moves forward relative to the rest of the dummy, while, according to the commenter, the WorldSID dummy's shoulder moves rearward. The Alliance believes that a rearward motion is consistent with that exhibited by post mortem human subjects (PMHS) in rigid impactor tests. The commenter did not demonstrate the relevance to this rulemaking of movement of the dummy's shoulder frontward or rearward. Use of the dummy in vehicle crash tests has indicated no detrimental effects due to shoulder design, such as rib flat-topping or distortion of signals, showing that the shoulder has reached its limit for range of motion or has otherwise performed unacceptably due to a forward motion of the clavicles.

In conclusion, the data show that there are no deficiencies with the ES-2re that justify limiting its injury assessment to that of HIC only. The data show that there is virtually no effect due to oblique loading in the driver ES-2re deflection readings in oblique pole tests as compared to perpendicular pole impacts. The data also do not demonstrate an indication of sensitivity to oblique loading in MDB tests. To the contrary, the test data from the Impala test show that the abdominal response of the ES-2re in the rear passenger position in the MDB test detected critical loading by intruding vehicle structures at the lower torso level. Further discussion of the agency's response to comments about the biofidelity of the ES-2re can be found in the December 14, 2006 49 CFR Part 572 final rule on the ES-2re (see Docket 25441).

Anthropomorphic test devices are constantly evolving and advancing due in part to worldwide research efforts toward improving the biofidelity, durability and injury-measurement capabilities of the test devices. Adopting the ES-2re and the injury assessment reference values associated with the risk of injury to an occupant's thorax, abdomen and pelvis will enhance the safety of occupants in side impacts. In a NASS study of side impact crashes, it was estimated that between 8.5 percent

and 21.8 percent of all AIS 3+ injuries are to the abdomen of restrained near side front seat occupants.³⁶ The important gains in occupant protection that can be achieved by the ES-2re should not be delayed or lost on the grounds that a more advanced test dummy may be available in the future.

2. The 5th Percentile Female Dummy

A. The 5th Percentile Adult Female Dummy Is an Integral Part of This Upgrade

The Alliance suggested that NHTSA should incorporate only a 50th percentile male test dummy in both the pole and MDB tests and completely forego use of the 5th percentile female dummy in the final rule. The commenter believed that the agency did not provide data showing that real-world safety will be improved by use of the 5th percentile dummy “beyond the benefits provided by the industry’s front-to-side voluntary commitment and the IIHS side impact rating test.”

i. Need for the 5th Percentile Dummy in the Pole Test

According to the Alliance, crash data³⁷ demonstrate that narrow object

side impacts are “far more likely to involve 50th percentile-male-sized occupants than 5th percentile-female-sized occupants.”³⁸ According to the Alliance, only 4.7 percent of nearside front outboard occupant crashes involved a tree or pole impact, and only 0.28 percent of nearside front outboard occupant crashes with trees or poles involved occupants with a height of 47 to 61 inches. Therefore, the Alliance argued, only the 50th percentile adult male dummy is needed in the pole test.

We have considered the Alliance’s reasoning but conclude that: (a) Tree/pole impacts comprise a significant safety problem (b) involving smaller occupants.

Tree/Pole Impacts

We disagree with several of the Alliance’s claims. The first concerns the magnitude of the side impact safety problem posed by tree or pole impacts. The commenter believes that 4.7 percent of nearside front outboard occupant crashes involved a tree or pole impact. That determination was based on the commenter’s analysis of all side crashes occurring in 1990–2002 that resulted in any injury, from minor (AIS 1) to fatal.³⁹ Because there are many more AIS 1 and

2 injuries in the accident database than AIS 3+ injuries, we believe that including AIS 1 and 2 injuries in the analysis masks the frequency of tree or pole impacts in crashes causing serious (AIS 3+) injuries and underestimates the harm addressed by this rulemaking. As discussed below and in the NPRM, an analysis that is focused on side crashes⁴⁰ resulting in a fatal injury shows that 21 percent of these crashes involved side impacts with rigid narrow objects.

As discussed in the NPRM, NHTSA analyzed fatalities in the 1991, 1995, and 1999 FARS files using non-rollover, near-side impact data. We have now also updated the analysis for 2004 FARS.⁴¹ The fatalities occurred in the front and rear seats of light vehicles in side impacts with various objects. The percentage of vehicle-to-rigid narrow object impacts has remained stable at approximately 23 percent of the total number of fatal side impact crashes. The percentage of collisions with LTVs has increased, while the percentage of collisions with passenger cars has decreased over time. The results of the analysis are presented below in Table 10:

TABLE 10.—OCCUPANT FATALITY DISTRIBUTION
[Non-rollover near-side impacts]

	Collisions with passenger cars (percent)	Collisions with LTVs (percent)	Collisions with rigid narrow objects (percent)	Collisions with other vehicles/objects (percent)
FARS 1991 MY 1987 and Later Light Vehicles	28.9	27.1	20.1	24.0
FARS 1995 MY 1991 and Later Light Vehicles	24.8	33.0	21.2	21.0
FARS 1999 MY 1995 and Later Light Vehicles	20.5	36.3	21.0	22.2
FARS 2004 MY 2000 and Later Light Vehicles	15.4	38.5	23.2	22.9

Given the number of tree or pole side crashes that occur, the analysis shows that tree or pole side impacts are over-represented in terms of fatally injured occupants.

Small Stature Occupants Are Seriously Injured in Tree/Pole Impacts

The second aspect of the Alliance’s reasoning with which we disagree concerns the involvement of small stature occupants in tree or pole side

crashes. The commenter believes that only 0.28 percent of nearside front outboard occupant crashes with trees or poles involved occupants with a height of 47 to 61 inches, and so the 5th percentile female dummy is not needed in the pole test.

We analyzed accident data on drivers involved in side impacts to examine characteristics of drivers seriously injured or killed in tree or pole impacts. We found in analyzing 1990–2001

National Automotive Sampling System Crashworthiness Data System (NASS CDS)⁴² crash data that smaller stature drivers (height up to 5 feet 4 inches) comprise approximately 28 percent of seriously or fatally injured drivers in narrow object side impacts. The 1990–2001 NASS CDS data also indicate that there are differences in the body region distribution of serious injuries between small and medium stature occupants that are seriously injured in these side

³⁶ Samaha, R.S., Elliot, D., “NHTSA Side Impact Research: Motivation for Upgraded Test Procedures,” *supra*.

³⁷ The commenter performed an analysis of 1990–2002 NASS CDS side crashes with a lateral delta-V range of 12–25 mph, involving model years of 1990 or newer vehicles in non-rollover side impacts (nearside front-outboard occupants of age 12 years or older with a fatality or known MAIS, and no total ejections).

³⁸ The Alliance believed that the 5th percentile adult female dummy represented occupants only of heights of 47 to 61 inches.

³⁹ Lateral delta-V range of 12–25 mph, model years of 1990 or newer vehicles, non-rollover side impacts, nearside front-outboard occupants of age 12 years or older.

⁴⁰ 2001 FARS nearside non-rollover fatalities, model year 1995 and newer vehicles struck vehicle.

⁴¹ The slight differences in distributions in Table 10 of this preamble and those of Table 1 of the

NPRM (69 FR at 27993) are due to new runs of the data and minor differences in the definition of “other” vehicle types.

⁴² NASS CDS has detailed data on a representative, random sample of thousands of minor, serious, and fatal crashes. Field research teams located at Primary Sampling Units across the country study about 5,000 crashes a year involving passenger cars, light trucks, vans, and utility vehicles.

collisions. The data suggest that smaller stature occupants have a higher proportion of head, abdominal and pelvic injuries than medium stature occupants, and a lesser proportion of chest injuries. (“NHTSA Side Impact Research: Motivation for Upgraded Test Procedures,” Samaha, *et al.* (2003).)

The appropriateness of an anthropomorphic test device for a dynamic test depends in part on its ability to represent occupants involved or injured in the crash simulated by the dynamic test. There are only two side impact dummies existing today representing the sizes of occupants seriously injured in side impacts: the SID-IIs and the mid-size adult male dummies (e.g., the ES-2re). The height of a smaller stature (5th percentile) adult female is 59 inches (4 feet 11 inches). The height of a mid-size adult male is about 69 inches (5 feet 9 inches). The mid-point between the two is 64 inches (5 feet 4 inches). Drivers less than 64 inches in height are usually female and/or elderly, and are closer in physiology to a 5th percentile female than to a 50th percentile male. (Drivers taller than 64 inches could also be represented by the SID-IIs since driver height falls along a continuum. However, for purposes of our analysis of the impacts of this rulemaking, we had to make a cut-off and did so at 64 inches.) Accordingly, we have determined that the SID-IIs, with its height of 59 inches (4 feet 11 inches), is representative of occupants of heights up to 64 inches (5 feet 4 inches). The assumption that a 5th percentile adult female dummy is representative of occupants of heights up to 64 inches (5 feet 4 inches) is consistent with the approach taken by the agency in analyzing the impacts of advanced air bags under FMVSS No. 208, “Occupant crash protection.”

The Alliance recommended that NHTSA assume that the SID-IIs only represented occupants with a height of 47 (3 feet 11 inches) to 61 (5 feet 1 inch) inches. We believe this assumption is overly restrictive. Sixty-two-, 63- and 64-inch tall adults, mostly women, are more similar in build to the SID-IIs than to the 50th percentile male dummy.

As explained in the next section, including the 5th percentile female dummy in the oblique pole test will gain real world benefits beyond those attained using just a mid-size adult male dummy in the pole test. We estimate that the inclusion of the SID-IIs in the oblique pole test will save an additional 78 lives beyond the fatalities saved by changes to vehicle designs to meet an oblique pole test using the 50th percentile male dummy alone. These

lives lost annually of smaller stature occupants, many of whom are elderly, constitutes a safety problem that incorporation of the SID-IIs will address.

Current Side Air Bags Will Be Made Even Better To Enhance Protection to Smaller Stature Drivers

Current combination head/thorax air bags and side curtains generally perform well in the IIHS consumer information program side impact tests. They will do even better under our regulation.

The Alliance believed that we should not be concerned that some side air bag systems we tested did not meet the IARVs with the SID-IIs. The commenter believed that “current side air bag systems are proving to be very effective in real-world side impacts * * * [and] that the agency’s concerns are unfounded and unwarranted regarding current side airbag designs failing to activate properly or providing sufficient coverage in real-world crash situations.”

The primary impact of this regulation on motor vehicle safety will be to ensure that head protection is provided in passenger vehicles, and to improve on the protection of current bags. In our 214 fleet testing program, current side air bags did not always meet the proposed criteria when tested with the SID-IIs dummy. In the agency’s tests of 10 vehicles, seven exceeded the injury criteria for the 5th percentile female dummy in the oblique pole test (four exceeded HIC, four exceeded the lower spine, and seven exceeded the pelvic force criteria). In the Ford Five Hundred and Saturn Ion tests, we observed that the side air bags deployed after the 5th percentile female dummy had already moved toward the very front of the air bag at pole contact and had hit a portion of the air curtain/tether interface that was not inflated to cushion the impact, which resulted in HIC readings of 1,173 (Ford Five Hundred) and 5,203 (Saturn Ion). In the Ford Expedition test, we observed that the SID-IIs rotated around the curtain and contacted a portion of the air curtain/tether interface that was not inflated to cushion the impact, which resulted in an HIC value of 5,661.

If the ES-2re were the only test dummy used in the pole test, countermeasures installed for the ES-2re might not protect the population (shorter and/or elderly drivers) represented by the 5th percentile female dummy. In the four air bag curtain tests discussed above, the HIC values for the ES-2re were moderate to low. The 5th percentile female dummy’s head is positioned lower than that of the ES-2re because of sitting height differences between the two dummies. The SID-IIs

is also farther forward than the ES-2re adult male dummy, which leads to differences in the interplay between the dummy and the vehicle side structure, roof and side air bag system. The differences in size and sitting position between the two dummies affects more than HIC responses. In the agency’s oblique pole test of the Volkswagen Jetta, the pelvic force reading of the SID-IIs was 7,876 N, while the vehicle met all the IARVs for the 50th percentile male dummy.

Air bag sensors could also be improved. As discussed in the NPRM (69 FR at 27998), the side air bags in two vehicles that were certified as meeting the requirements of a perpendicular crash test (the FMVSS No. 201 90-degree pole test) did not deploy when tested with the 5th percentile female dummy in the oblique pole test. We do not consider this to be a matter of a test artifact or other anomaly of the laboratory test conditions. We conclude that the oblique localized loading in the pole test (from the two distinct narrow impact locations corresponding to the seating positions of both sizes of test dummies) will induce more robust crash sensors that will lead to further protection in the field.

ii. Need for the 5th Percentile Dummy in the MDB Test

The Alliance believed that crash data demonstrate that occupants with heights less than 65 inches are involved in vehicle-to-vehicle side impacts with a “significant frequency,” i.e., that adult male and adult females are similarly represented in vehicle-to-vehicle crashes in the delta-V range of 12–25 mph, in which a front, outboard struck-side occupant receives a serious-to-fatal injury. The commenter also determined that vehicle-to-vehicle side impacts are significantly more frequent compared to tree/pole side impacts. However, the commenter believed that “[T]he industry’s voluntary agreement already includes requirements for an MDB test using a 5th percentile female dummy; we believe NHTSA has not demonstrated the need to overlay this agreement with a 5th percentile female MDB regulatory test requirement.”

Ferrari stated that we did not clearly identify the expected benefits from the use of the dummy in the MDB test. Ferrari further stated that, even if the population represented by the 5th percentile female dummy were at a greater risk of head and abdominal injuries, the SID-IIs dummy would not provide any increased benefit to this population because the dummy “does not have any feature able to measure abdominal injuries, and the risk of

injuries to the head is much better assessed by the pole impact test (not the MDB test). The introduction of the SID-2s [sic], lacking even a chest deflection criterion, would not supplement in any way the protection provided by the introduction of the ES-2 or ES-2re.”

Agency response: Based on our evaluation of available data, we have decided to require only one MDB test (per side of the vehicle). The MDB test specifies use of an ES-2re (50th percentile adult male) dummy in the front seating position and a SID-IIs (5th percentile adult female) dummy in the rear.

The NPRM proposed to use the ES-2re dummy in both the front and rear outboard seating positions on both sides of the vehicle, and also proposed use of the SID-IIs dummy in the front and rear outboard seating positions on both sides of the vehicle. We issued the proposal based in part on crash data indicating that 35 percent of all serious and fatal injuries to nearside occupants occurred to occupants 5 feet 4 inches (or 163 centimeters) or less, which are best represented by the 5th percentile female dummy (69 FR at 27991). We also considered the results of two MDB tests with the SID-IIsFRG dummy that had indicated a need for the dummy. In a test of a 2001 Ford Focus, the pelvic force was exceeded for the driver dummy (5,621 N). In a test of a 2002 Chevrolet Impala, the left rear dummy's lower spine acceleration and pelvic force criteria were exceeded (89 g and 5,711 N, respectively). Based on those results, we expected that improvements to the arm rest area and other structural components would be required to improve protection for the 5th percentile occupants (69 FR at 28011).

Since the NPRM, we have conducted eight MDB tests with the SID-IIs dummy in predominantly model year 2005 vehicles. Our crash test results have shown that vehicles newer than the 2001 Focus and the 2002 Impala are generally able to meet the proposed injury criteria when tested with this dummy. (The 2001 Focus has since undergone a mid-cycle design change with head/torso combo bags becoming optional for model year 2005 vehicles. The 2002 Impala has since been redesigned with model year 2006 vehicles having curtain and thorax bags as standard equipment.)

MDB Test of the Front Seat

For the driver dummy, 7 of 8 vehicles met the criteria. The one exception for the front seat was the 2005 Saturn Ion, which resulted in the SID-IIs driver dummy exceeding the pelvic force criterion (8,993 N).

The Saturn Ion in the test was equipped with an air curtain, but lacked a thorax-mounted side air bag. The lack of thoracic air bag protection may have led to the high pelvic force measured by the dummy. In our pole testing, the Saturn Ion exceeded the limits on HIC (5,203), lower spine acceleration (110 g) and pelvic force (5,755 N). It also scored “poor” in the IIHS side impact crashworthiness evaluation. Based on this complete array of testing with this vehicle, we believe that needed improvements to comply with the oblique pole tests of this final rule will likely address the one SID-IIs driver dummy failure that the agency observed in its MDB test.

Thus, based on the available data that show:

(a) All vehicles except the Ion meeting the MDB test when tested with the SID-IIs in the front seat; and

(b) Countermeasures to address the Ion's failing the pelvic criterion in the front seat of the pole test when tested with the SID-IIs could address the failure of the vehicle to meet the pelvic criterion in the MDB front seat test—

The agency has decided not to adopt an MDB test with the SID-IIs in the front seating positions.

The benefits from an MDB test with the SID-IIs in the front seat will likely be absorbed by the SID-IIs front seat oblique pole test requirements, as suggested by some of the commenters. That is, a countermeasure such as a thorax air bag in the front seat of the Ion installed to meet the pole test requirements could also enable the Ion to meet the pelvic criterion of the MDB test. Thus, the MDB test of the front seat with the SID-IIs dummy is unlikely to lead to improved occupant protection, and is not warranted for adoption into FMVSS No. 214.

(On the other hand, adoption of the ES-2re dummy in the MDB tests to test the front seat of vehicles is warranted. The reasons for adopting the ES-2re in the front seat of this test are explained in section VI.c of this preamble.)

MDB Test of the Rear Seat

The test of the rear seat with the SID-IIs resulted in high pelvic forces in the Honda Accord and in the Suzuki Forenza. We were concerned about these results because rear seat occupants are predominantly made up of smaller stature occupants, e.g., children, who more closely resemble the anthropometry of the SID-IIs than a 50th percentile adult male. All vehicles met all the criteria proposed in the NPRM when tested with the ES-2re 50th percentile male dummy.

In addition, we observed that in the tests of the VW Jetta, Saturn Ion, Ford Five Hundred, and Honda Accord, and the Suzuki Forenza,⁴³ the SID-IIs dummy in the rear seat of the MDB test had elevated thoracic and/or abdominal rib deflections that were not observed with the rear seat ES-2re dummy. We felt that the rib deflections of the SID-IIs were noteworthy, since many experts consider deflection to be the best predictor of thoracic injury.⁴⁴ We believed that the SID-IIs's elevated rib deflections in the rear seat indicated that side impact crashworthiness designs in the rear were possibly in need of improvement to better protect rear seat occupants, particularly children and other smaller stature occupants.

Incorporation of the SID-IIs into the rear seat MDB test enables us to monitor readily the rib deflections measured in the test⁴⁵ to assess how the rear seat environment is protecting children and small occupants. While the agency did not propose thoracic and abdominal rib deflection requirements for the 5th percentile female dummy and thus is not adopting rib deflection limits in this final rule, we are considering a future rulemaking to adopt limits on the thoracic and abdominal rib deflections measured by the SID-IIs in the FMVSS No. 214 MDB and pole tests. The rulemaking could be a part of a rulemaking to incorporate WorldSID into FMVSS No. 214, if such a rulemaking were to ensue, or it could be developed on its own.

Incorporation of the SID-IIs into FMVSS No. 214's MDB test of the rear seat enhances protection of rear seat occupants also because the 5th percentile adult female dummy better represents the anthropometry of rear seat occupants than the SID or the ES-2re (50th percentile male dummies). The average seated height of rear-outboard occupants is approximately 81.6 centimeters (cm).⁴⁶ The sitting

⁴³ The Forenza was not tested with the ES-2re dummy.

⁴⁴ Kuppa, S., Eppinger, R., McKoy, F., Nguyen, T., Yoganandan, N., Pintar, F., “Development of Side Impact Thoracic Injury Criteria and their Application to the Modified ES-2 Dummy with Rib Extensions (ES-2re),” Stapp Car Crash Journal, Vol. 47 October 2003, The Stapp Association. A paper demonstrating that deflections are the best predictors of injury in frontal impacts is by Kent *et al.* (Kent, R., Crandall, J., Bolton, J., Prasad, P., Nusholtz, G., Mertz, H., “The Influence of Superficial Soft Tissues and Restraint Condition on Thoracic Skeletal Injury Prediction,” Stapp Car Crash Journal, Vol. 45, November 2003, The Stapp Association.)

⁴⁵ We will also monitor the SID-IIs rib deflections in the oblique pole test.

⁴⁶ A ratio of sitting height to standing height, developed by the University of Michigan

height of the SID-IIs is approximately 78.8 cm, while that of the ES-2re is 88.4 cm. The SID-IIs is closer in height to the average outboard rear seat occupant than the SID or the ES-2re. The SID-IIs's ability to assess the risk of head injury through the measurement of HIC will better ensure that head protection is provided to children and smaller stature adults in rear seating positions than through use of the 50th percentile adult male test dummies.

Safety will also be enhanced by this final rule using the SID-IIs in the rear seat since this smaller sized dummy will fit in more vehicles, and therefore exclude few vehicles that cannot accommodate the 50th percentile male dummy. (Currently, S3(b) of FMVSS No. 214 excludes the rear seat in passenger cars that have rear seating areas that are so small that the 50th percentile adult male test dummy cannot be accommodated according to the positioning procedure specified in the standard.) We believe use of the SID-IIs in the rear will provide the agency with the ability to test more vehicles that have rear seats too small to accommodate the mid-size male dummy. On the other hand, we have decided not to adopt the ES-2re dummy in the rear seat of the MDB tests. Our reasons are explained in section VI.c of this preamble.

iii. Beyond the Voluntary Commitment

Test data demonstrate the benefit of having the SID-IIs in the pole test, notwithstanding the industry's voluntary agreement.⁴⁷ In the agency's side impact test program, vehicles that were rated "Good" in the IIHS side crashworthiness evaluation when tested with the SID-IIs exceeded one or more of the injury criteria of this rule when tested with the SID-IIs in our pole test program. In the pole test of the Volkswagen Jetta, which IIHS scored "Good," the pelvic force (7,876 N) exceeded the IARV (limit 5,525 N). In the pole test of the Honda Accord, the SID-IIs's pelvic force criterion was over 10,000 N. The industry's voluntary commitment does not commit to reducing these pelvic forces. However,

⁴⁷Transportation Research Institute (UMTRI), is approximately 0.54. Applying this ratio to the real world rear seat occupant data, the mean sitting height of occupants in rear outboard seats (excluding those in infant and toddler child restraint systems) is 81.6 cm.

⁴⁸The industry's voluntary commitment is a commitment to meet IIHS's recommended practice of HIC₁₅ performance of 779 or less for a SID-IIs crash dummy in the driver's seating position and does not include at this time performance criteria for other body regions, specifically, the thoracic and abdominal regions. The voluntary commitment also does not address the right front or rear seat passenger positions at this time.

we can ensure improvement as a result of manufacturers' meeting the pole requirements of this final rule.

B. However, Not All of the Proposed FRG Changes Are Needed

The SID-IIs test dummy has been used by Transport Canada in crash tests since the late 1990s and is used by IIHS in its consumer information program for ranking vehicle performance. In its initial evaluation of the dummy, NHTSA had found some durability problems with the dummy's shoulder and ribcage and some chest transducer mechanical failures. To improve the durability of the dummy, NHTSA modified the dummy to incorporate, among other things, floating rib guides to better stabilize the dummy's ribs. (See 69 FR at 70948.)

The durability problem arose in 6.7 meters per second (m/s) sled tests of the SID-IIs Build C dummy using a rigid wall with a 101 mm abdominal offset.⁴⁸ Damage in some of the tests included deformed abdominal ribs, bent abdominal potentiometer shafts, and/or gouged damping material, caused by vertical motion of the ribs and/or excessive rib compression. The agency concluded that, under those test circumstances, portions of the abdominal and thorax ribs during their extreme compression were extending beyond the boundaries of existing rib guides, and that under some test conditions, were moving out of their initial plane of translation. Such out of plane translation caused the linear deflection transducer pivots to exceed their angular motion limits, resulting in transducer shaft failures and rib damping material gouging due to interaction between the extended ribs and the rib guides.

NHTSA developed the floating rib guide system to prevent the compressed ribs from leaving the outside perimeter of the rib guides and thereby prevent damage to surrounding areas. Rib guides were used to "float" with the ribs as they expanded in the anterior-posterior direction during rib compression. This was intended not only to eliminate the problem of ribs extending outside the boundaries of the rib guides, but also retain the ribs in their initial plane and thereby prevent damage to the transducer shaft. To further prevent damage (bending) of potentiometer shafts and damage to potentiometer housings, the rib stops were reshaped

⁴⁸The agency conducted the tests to replicate biomechanical sled test impact configurations previously reported by Maltese et al. ("Response Corridors of Human Surrogates in Lateral Impacts," Technical Paper 2002-22-0017. Proceedings, 46th Stapp Car Crash Conference, 2002).

and changed from a flexible urethane material to vinyl-coated aluminum. The maximum lateral rib deflection of the dummy was also reduced from 69 mm to 60 mm to further protect the instrumentation.⁴⁹

While NHTSA tentatively determined there was a need for the FRG modifications, the agency noted in the December 8, 2004 Part 572 NPRM that there were other views as to the need for the FRG changes to the dummy (69 FR at 70954). The NPRM noted that Transport Canada, IIHS and the industry had used the unmodified SID-IIs dummy for several years to their satisfaction.

Comments on the proposed FRG changes: All commenters responding to this issue were opposed to or expressed concern about adopting the FRG modifications to the SID-IIs dummy. Commenters believed that the unmodified Build Level C and/or Build Level D dummies were sufficiently durable for crash tests. In its October 14, 2004 comments on the NPRM, the Alliance stated that the OSRP SID-IIs Upgrade Task Group⁵⁰ had agreed to enhancements of the SID-IIs Build C dummy or modifications incorporated into the Build D dummy, but, the Alliance emphasized, OSRP had steadfastly maintained that there was no durability problem requiring the floating rib guide change to the dummy's thorax. The Alliance believed that NHTSA's Vehicle Research and Test Center (VRTC)—

proposed the addition of floating rib guides to the SID-IIs dummy based on a small series of sled tests, including a single abdominal offset sled test in which the ribs were damaged and exited the original rib guides. The test was performed with an improperly positioned and improperly scaled abdominal plate that simulated a rigid armrest. This setup produced a very severe impact condition for the SID-IIs (AF05) dummy. Instead of being scaled for the AF05, the test was performed with an abdominal plate that was offset 100 mm, which are the test conditions for the ES-2 (AM50) dummy. Further, the 100 mm offset is at the extreme end of the range of armrest width in typical vehicles. In addition, the abdominal plate is rigid and therefore provided a more severe impact surface than do typically padded and deformable vehicle armrests. This test setup

⁴⁹The FRG design also encompassed other changes to improve the durability of the dummy. The shoulder rib guide of the dummy was reshaped and deepened beyond the front edge of the shoulder rib to keep the shoulder rib from moving vertically during its compression. The damping material of the shoulder rib assembly was made thinner and spanned the entire width of the steel band.

⁵⁰The Alliance stated in its comment, "The OSRP SID-IIs Upgrade Task Group is responsible for coordinating, evaluating and approving any design modifications to the SID-IIs dummy, originally designed in 1994-95."

produced an impact condition for the AF05 dummy more severe than that of full-scale vehicle tests, since the dummy's ribs were damaged in the sled test but no rib damage occurred in the vehicle tests using the SID-IIs Version C.

The Alliance further stated that the agency's concern about the accuracy of the acceleration and deflection measurements of the Build Level C dummy due to the ribs not staying in place "does not follow logically because it is quite normal to have the ribs deform during impact by expanding in the fore-aft dimension of the chest. The fact that they change shape and do not stay in place has nothing to do with the accuracy of the deflection measurements."

IIHS also objected to the agency's use of the 6.7 m/s test. IIHS found the FRG version of the SID-IIs "an unacceptable and unnecessary compromise of the original dummy's biofidelity to address an unproven durability problem" (March 4, 2005 comment to Docket 18865). IIHS stated:

Not only have NHTSA's own vehicle crash tests failed to show any durability problems with the original dummy design, but Institute and industry experience confirms the dummy is durable enough for crash testing. As of October 2004 the Institute had conducted 48 side impact tests with the SID-IIs dummies positioned in the driver and rear outboard seating positions, for a total of 96 SID-IIs test exposures. Of these only 6 caused any damage to the dummy; in 4 tests the dummy's shoulder was damaged, and in 2 tests one of the abdominal ribs did not pass post-test verification. Similar trends are found in the Occupant Safety Research Partnership (OSRP) dataset, which includes tests conducted by DaimlerChrysler, General Motors, the Institute, and Transport Canada. Of the 241 SID-IIs test exposures (or 1,446 exposures to the dummies' individual ribs), only 21 tests (8.7 percent) caused any dummy damage; of these only 3 tests (0.3 percent of total rib exposures) exhibited any evidence of ribs catching on the vertical guides.

IIHS recommended that NHTSA adopt the SID-IIs Build Level C or the Build Level D dummy into FMVSS No. 214. IIHS stated (Docket 18865):

Build Level D would incorporate many of the design upgrades currently in the FRG version that would improve the dummy while maintaining its high biofidelity rating. The changes IIHS supports for build level D include redesign of the shoulder rib and rib guide, neck mounting bracket, rib stops, and spine box. Using either C- or D-level SID-IIs would permit the agency to draw on the dummy's accumulated crash test experience to incorporate rib deflection data among the FMVSS 214 requirements.

Some commenters expressed a view that the SID-IIsFRG dummy was itself not an adequate a test device for

incorporation into 49 CFR part 572. The Alliance stated that in full vehicle crash tests, there are significant differences in the shape and magnitude of the chest deflection responses of the SID-IIsFRG and the Build C dummy, with the SID-IIsFRG having "greatly reduced" deflections. The Alliance stated that researchers at Transport Canada and elsewhere found "no flat-topping in the original SID-IIs, but severe flat topping in the SID-IIsFRG." Nissan stated that it has observed scratching of the SID-IIsFRG's rib guides created by rib contact and was concerned that this phenomenon could reduce test repeatability using the dummy over time, or may negatively affect the accuracy of the rib data.

Some commenters believed that it was more advantageous to adopt the SID-IIs Build Level C or Build Level D dummy than the SID-IIsFRG. The Alliance stated that the ISO 9790 biofidelity rating of the SID-IIsFRG is only "fair" (5.9), while that of the SID-IIs Build C was "good" (7.0). IIHS expressed serious concern that the FRG modification "has considerably degraded" the SID-IIs dummy's biofidelity. IIHS supported the Build Level C or D dummies in the rulemaking because it would permit the agency to incorporate rib deflection data in test requirements. IIHS stated:

Without rib deflection limits for tests with the small dummy, the proposed side impact standard will not establish the same minimum levels of protection for vehicle occupants of various sizes. It is disappointing that part of NHTSA's reason for not including SID-IIsFRG rib deflection limits was the need to study the issue further. By favoring the FRG modified dummy the agency is ignoring the accumulated test experience with the original dummy.

Advocates expressed "misgivings over the lack of chest deflection measurement capability for the 5th percentile SID-IIsFRG female dummy." Honda expressed concern that the SID-IIsFRG is not commonly used by automakers today. Honda stated that, "The use of SID-IIs [Build Level C or D] will expand because it is specified in the [industry's] voluntarily commitment on FMVSS No. 214." TRW said that using "known and accepted" test dummies could help expedite motor vehicle manufacturers' meeting their "voluntary commitment" to install inflatable side head protection systems.

Agency response: After reviewing the comments and other information, we have decided to use the SID-IIs Build

Level D test dummy, rather than the FRG dummy, in FMVSS No. 214.⁵¹

The SID-IIsFRG floating rib guide concept was developed to improve the durability of the SID-IIs dummy under extremely severe impact conditions. We have concluded that data now available to the agency do not support a need for all of the floating rib guide design. The test conditions precipitating the development of the FRG were exceptionally severe and appear to be unlike vehicle crashes to which the crash dummy is exposed.

The OSRP task group and IIHS noted that the type of damage reported by NHTSA in VRTC sled tests was not experienced in their full scale vehicle crash tests. Our own testing bears this out. Since the time of the NPRM, NHTSA has used the SID-IIs (Build D) in over 24 oblique pole and MDB crash tests without seeing structural or functional problems with the dummy. In addition, the agency evaluated four SID-IIs Build D dummies in extensive component, sled, and pole and MDB vehicle crash tests without sustaining functionality and durability problems.

The Build D dummy has many of the enhancements of the SID-IIsFRG and some enhancements similar to FRG features, including new rib stops, larger motion ranges of potentiometers pivots, 1/2 inch diameter potentiometers, and enhancements to the shoulder structure. The shoulder enhancements address bending deformation of the shoulder rib, delamination and/or gouging damage to the deflection transducer. All of these enhancements have improved the structural integrity of the dummy and have eliminated the need for all of the floating rib guide design changes.

We further believe that there are advantages to adopting the SID-IIs Build D dummy rather than the SID-IIsFRG beyond what is needed for the durability of the dummy. As noted by the commenters, while the FRG was very successful in containing the ribs within the rib guides and in preventing potentiometer-transducer failures, the floating rib guides added mass and additional stiffness to the ribs. As a result, the FRG became less human-like, rib deflections seriously reduced, and the shape of the deflection-time histories changed compared to testing under similar loading conditions without the FRG. *Id.*

⁵¹ A final rule adopting the Build Level D into 49 CFR part 572 was published December 14, 2006, 71 FR 75342, Docket 25442. The part 572 final rule discusses the biofidelity, repeatability, reproducibility, durability, and other aspects of the dummy. The document discusses the agency's decision to adopt some but not the entirety of the floating rib guide design.

IIHS uses the SID-IIs in its side impact consumer information program. IIHS noted in its comments to the NPRM that Build D would incorporate many of the design upgrades currently in the FRG version that would improve the dummy while maintaining the dummy's high biofidelity rating. Transport Canada plans to continue using the SID-IIs in its research program. Using Build D in FMVSS No. 214 means that the same dummy will be used in governmental and non-governmental consumer information and research programs. This consistency will enhance the testing of vehicles by making the test results from NHTSA, Transport Canada, IIHS and industry in many ways more comparable. Using the same test dummy will also more effectively focus research and design efforts on more consistent and effective countermeasures that will most successfully protect smaller stature occupants. Accordingly, this final rule adopts use of the SID-IIs test dummy into the compliance tests of FMVSS No. 214.

b. Aspects of the Pole Test Procedure

In the NPRM, the agency proposed a dynamic vehicle-to-pole test that is similar to the one used to test some vehicles under FMVSS No. 201, except that the test procedure would involve an angle of impact of 75 degrees (instead of 90 degrees) and a test speed of up to and including 32 km/h (20 mph) (instead of 24–29 km/h (15–18 mph)). We further proposed to amend FMVSS No. 201 such that, if the oblique 32 km/h (20 mph) pole test were added to FMVSS No. 214, vehicles certified to the latter test would be excluded from having to be certified to FMVSS No. 201's 90 degree, 29 km/h (18 mph) pole test.

Virtually all of the commenters supported the adoption of a pole test to enhance side impact occupant protection further. These commenters included the Alliance, which supported a 32 km/h (20 mph) test using a 75-degree oblique impact angle. However, Ferrari, Lotus, and Maserati supported a pole test that was harmonized with the pole test of EuroNCAP (perpendicular 29 km/h (18 mph) impact).

1. Speed

The NPRM proposed (in section S9.1.1 of the proposed regulatory text) that each vehicle must meet the oblique pole test requirements when tested "at any speed up to and including 32 km/h (20 mph)." The agency also requested comments on the alternative of a 29 km/h (18 mph) test speed, which is used in the optional perpendicular pole test of FMVSS No. 201.

Nearly all commenters supported the 32 km/h (20 mph) test speed. The Alliance supported a 32 km/h (20 mph) test speed, but recommended bounding it with a lower bound as is done with the FMVSS No. 201 optional pole test. FMVSS No. 201 sets a lower limit of 24 km/h (15 mph) in the pole test. In setting the FMVSS No. 201 final rule, NHTSA concluded that a 24 km/h (15 mph) lower limit was appropriate because 24 km/h (15 mph) represented the point at which occupants experience moderate to serious (AIS 2 and AIS 3) injuries. The agency believed that testing at impact speeds below which a dynamic head protection system would deploy or offer any meaningful safety benefits would serve no purpose. (64 FR 69665, December 14, 1999.) The Alliance and DaimlerChrysler commented that, since the increase in lateral velocity from a 29 km/h (18 mph) perpendicular pole test to a 32 km/h (20 mph) 75-degree oblique test is only 1.3 mph, the minimum oblique test speed should be 1 mph over the current minimum perpendicular test speed of 24 km/h (15 mph) in FMVSS No. 201.

Public Citizen expressed its support for a 32 km/h (20 mph) test speed, stating that such a speed "appropriately protects from the depth of intrusion that occurs when passenger cars are hit in the side by a pickup truck or SUV." A private individual, Mr. William Watson, believed that the designs needed to comply with the higher test speed would not place an undue burden upon manufacturers, but simply provide a higher margin of safety for occupants. Autoliv supported the higher test speed of 32 km/h (20 mph) on the basis that the commenter believed it would benefit more occupants in real world crashes. It also stated that the higher speed would present some challenges, particularly for the new criteria for thorax protection. However, Autoliv did not anticipate that these challenges would affect its ability to meet product demand during the proposed phase-in requirements. TRW believed that the side protection systems designed to meet the requirements of the NPRM could perform acceptably for out-of-position (OOP) occupants.

Opposed to the 32 km/h (20 mph) test speed were Ferrari and Maserati. Ferrari believed that increasing the pole test speed from 18 to 20 mph would be excessively burdensome, forcing manufacturers to redesign side structures and head protection side bags. Further, Ferrari believed that it would force an increase in the power of the head protection side bag, which might lead to an increased injury risk for children and occupants that are

OOP. The commenter believed that a pole test that is consistent with the EuroNCAP side pole impact test, i.e., an 18 mph perpendicular pole test, is the only way the test can be reasonable and practicable for small volume manufacturers.

Agency response: After carefully reviewing the comments, the agency has decided to adopt the pole test speed proposed in the NPRM. The oblique pole test procedure is conducted at any speed up to and including 32 km/h (20 mph). A higher test speed than 29 km/h (18 mph) will provide for a higher degree of safety and will benefit more occupants in the real world. As previously noted in the NPRM for this final rule, the agency found that crashes with a delta-V of 32 km/h (20 mph) or higher result in approximately half of the seriously injured occupants in narrow object side impact crashes (69 FR at 27997). A test conducted at 32 km/h (20 mph) maximum speed better represents the speed of real world crashes that result in serious injury than an 18-mph test. Based on our testing, we believe that it is feasible to meet the test requirements at 32 km/h (20 mph) and there would be little cost differential.

The practicability of meeting the requirements at the 32 km/h (20 mph) test speed was evidenced by the results of the agency's testing of the model year 2005 Subaru Forester, Volkswagen Beetle and Saab 9–3. We further note that the Beetle and the Saab 9–3 were also reported to be in compliance with the voluntary TWG requirements for out-of-position occupant assessment. Further, Autoliv and TRW commented that countermeasures could be designed to meet the higher speed oblique pole test, and also perform acceptably for out-of-position occupants.

We do not agree with the Alliance's suggestion of narrowing the oblique pole test speed range to 26 km/h to 32 km/h (16 to 20 mph). Limiting the test speed range would not ensure protection for side impact crashes that occur at delta-Vs under 26 km/h (16 mph). Our crash databases have shown that crashes with a delta-V of 26 km/h (16 mph) or less result in approximately a third of the fatalities and almost half of the MAIS 3–5 non-fatally injured occupants in near-side crashes. This analysis was based on front-outboard adult occupants with serious or fatal injuries in 1997–2003 NASS non-rollover, near-side crashes.⁵² Based on the crash data, we believe that there is

⁵² Delta-V distributions were derived from 1997–2003 CDS. Fatalities were adjusted to the 2001 FARS level, and non-fatal injuries to the 2001 GES level.

a demonstrated safety need to require manufacturers to ensure that vehicles provide improved protection in crashes below 26 km/h (16 mph).

We note that our motivation for this rulemaking was to establish a comprehensive side impact upgrade that required a systems approach to improve protection against head, thoracic, abdominal and pelvic injuries in a vehicle-to-pole test. It was not to duplicate FMVSS No. 201, which is primarily intended to address head impacts to the vehicle interior compartment. Only as a consideration of regulatory burden did we explore the degree to which the oblique pole test duplicated the requirements of FMVSS No. 201. While compliance with the FMVSS No. 214 oblique pole test supersedes the need to conduct a FMVSS No. 201 pole test, the agency did not intend to mimic the boundary conditions of that test.

Nor do we want to. When the 24 to 29 km/h (15 to 18 mph) pole test speed range was adopted in FMVSS No. 201 in 1999, side impact air bag systems were only starting to emerge. The goal of the agency in adopting a lower limit in FMVSS No. 201 was to reduce test burdens and to facilitate the introduction of these systems. The goal of today's rulemaking is to upgrade overall side impact protection, particularly in pole-type crashes. Since 1999, side impact air bags have become proven countermeasures that are effective in protecting against head, chest, abdominal and pelvic injuries, and in helping retain an occupant within the safe environment of the vehicle compartment. If the countermeasure is effective in reducing the risk of serious injury in crashes below 26 km/h (16 mph), we know of no compelling reason not to set a performance requirement that would necessitate its employment. If deploying the air bag is not needed to meet the injury criteria at a speed below a certain threshold, the manufacturer can make a manufacturing decision based on that fact when designing the vehicle. It may pose a test burden for the manufacturer to determine what that threshold should be, but it is a burden that is offset by the enhancement to side impact protection achievable in pole-type crashes.

For different vehicle designs, the threshold of when an air bag is needed to meet the injury criteria could differ. Establishing a lower test speed range in the oblique pole test could have the causal effect of establishing "design points" for restraint systems that may or may not be optimal to vehicle design. The threshold for air bag deployment (gray zone) can be dependent on many

vehicle attributes, such as side structure strength, energy absorption, air bag characteristics, etc. One vehicle design may be able to meet the injury criteria without an air bag at 24 km/h (15 mph), while another might need an air bag to meet an oblique pole test at that same speed. To prescribe a 26 km/h (16 mph) lower bound for the test speed might force a test condition that may not be ideal for occupant safety, given individual gray zones and compliance margins. Therefore, to ensure occupant protection at impact speeds below 26 km/h (16 mph), the final rule adopts the proposed oblique pole test conditions up to and including 32 km/h (20 mph), rather than a reduced range of 26 km/h (16 mph) to 32 km/h (20 mph).

The agency is also not persuaded by Ferrari's comments that the oblique pole test would be excessively burdensome. As discussed in the lead time section of this notice, the agency believes that vehicle manufacturers will have ample time to redesign their vehicles to meet the new requirements. By complying with the FMVSS No. 214 oblique test, excessive burden from complying with the FMVSS No. 201 pole test is removed.

2. Angle

The proposed 75-degree impact angle was generally supported except by Ferrari, Lotus and Maserati, which supported a 90-degree test similar to that of EuroNCAP. Ferrari added that an oblique pole test would force the manufacturers to focus their efforts on specific test conditions, detrimental to other ones (e.g., out-of-position occupants).

DaimlerChrysler believed that the perpendicular pole impact versus the 75-degree impact is not radically different and would provide similar levels of occupant protection. However, it stated that the perpendicular approach had qualitative benefits, such as simplicity in test setup, reproducibility, test dummy capability, and harmonization. The commenter stated that, although the agency has encountered specific cases in which a vehicle designed to comply with the perpendicular impact failed to detect the 75-degree oblique pole impact, DaimlerChrysler was not aware of this as a real world issue.

In support of the proposed impact angle, William Watson believed that the 75-degree pole test is a clear improvement over the perpendicular test in terms of the real world applicability and occupant protection. However, Mr. Watson stated that choosing one specific test angle might lead to restraint and sensor designs that

perform poorly for other angles. He believed that more than one impact angle should be tested, given the agency's data that suggests a difference of 15 degrees can produce significantly different sensing responses. Therefore, the commenter recommended that we retain the current perpendicular pole test and add the 75-degree oblique test as a supplemental requirement.

Agency response: The agency has decided to adopt the 75-degree impact angle proposed in the NPRM. The agency concludes that the oblique pole test will enhance safety because it is more representative of real-world side impact pole crashes than a 90-degree test. Frontal oblique crashes account for the highest percentage of seriously injured (MAIS 3+) near-side occupants in narrow object crashes, and our research indicates that the 75-degree impact is repeatable to simulate in a laboratory test.

A 75-degree approach angle is preferable to a 90-degree angle because the oblique impact exposes the dummy's head and thorax to both longitudinal and lateral crash forces that are typically experienced in real world side impacts. Weighted 1999–2001 NASS CDS side impact data show that in narrow object crashes, serious head and chest are dominant for both small and large stature occupants (69 FR 27998). The oblique pole test thus better emulates real world crash conditions than a perpendicular impact. NHTSA estimates that 311 lives would be saved by the oblique pole test using a 50th percentile adult male dummy and a 5th percentile adult female dummy,⁵³ while 224 lives would be saved by a perpendicular test using the same dummies. At a 3 percent discount rate, the cost per equivalent life saved is \$1.84 million for an oblique impact test requirement, and \$2.11 million for a perpendicular test requirement. At a 7 percent discount rate, the cost per equivalent life saved is \$2.31 million for the oblique test, and \$2.65 million for a perpendicular test.

Combination and other SIABs will generally be more protective if the agency adopted a 75-degree vehicle-to-pole test instead of a 90-degree one, particularly if the SID-IIs and ES-2re dummies were both used in the pole test. A SIAB just wide enough to meet a perpendicular pole test may be less protective in an oblique crash, as the occupant in an oblique crash will move laterally and forward at an angle rather than moving strictly laterally into the air

⁵³ With a curtain and 2-sensor system.

bag.⁵⁴ Some torso air bags may need to be redesigned to extend the air pocket further forward toward the A-pillar to provide coverage in a 75-degree oblique test. The VW Jetta, Honda Accord, and Subaru Forester received "Good" ratings in IIHS's side impact consumer information program when tested with the SID-IIs in a perpendicular impact. However, in our 214 fleet testing program with the SID-IIs, the VW Jetta resulted in a pelvic force value of 7,876 N, which exceeds the 5,525 N criterion of this final rule. In an oblique test, the SID-IIs in the Honda Accord measured a pelvic force value of 10,848 N. The Subaru Forester tested obliquely with the SID-IIs resulted in an abdominal deflection value of 45 mm. The oblique pole test will require these vehicles to provide protection of the 5th percentile adult female's abdomen/pelvis areas; these improvements would not generally result from a 90-degree test.

Other examples of how an oblique versus perpendicular impact can affect a vehicle's ability to provide head protection were provided in the NPRM. In a 75-degree test of a Nissan Maxima with the ES-2 dummy, the head of the dummy rotated into the pole notwithstanding the presence of a combination head/thorax side impact air bag. The HIC score was 5,254. In a 90-degree test, the same model year Maxima produced a HIC score of 130.⁵⁵

In our test program, four of the 10 vehicles tested with the SID-IIs had side air curtains that exceeded 1,000 HIC in the oblique impact (see the agency's docketed technical report on the test program, summarized in Section IV of this preamble, for a full discussion of the test program). The SID-IIs rotated around the front edge of the air bag or hit the front-most pocket of the curtain, which allowed for the dummy's head to contact a portion of the air curtain/tether interface that did not cushion the impact. HIC values were in the thousands. These curtains will be more protective when designed to meet oblique pole test requirements.

⁵⁴ Using two dummies in a 90-degree pole test will not necessarily lead to wider, more protective SIABs. If the SIAB were seat-mounted, the seat-mounted SIAB would travel along the seat track with the dummies. A SIAB could be tuned to meet a 90-degree pole test with both dummies and not provide benefits in an oblique impact.

⁵⁵ Other data from crash tests conducted in support of the NPRM showed that side air bags in a Ford Explorer and a Toyota Camry that were certified as meeting the requirements of the 90-degree pole test of FMVSS No. 201 did not inflate at all in an oblique (75 degree) test using a 5th percentile female dummy. The HIC results for the 5th percentile female (SID-IIsFRC) dummy placed in the driver's seats of these vehicles were in the thousands (13,125 and 8,706, respectively).

Wider and more protective side air curtains resulting from an oblique pole test will be beneficial in reducing partial occupant ejection through side windows.⁵⁶ There were 5,400 ejected fatalities through front side windows in 2001. The fatality rate for an ejected vehicle occupant is three times as great as that for an occupant who remains inside of the vehicle. The best way to reduce complete ejection is for occupants to wear their safety belts. However, of the 5,400 ejected fatalities through front side windows, 2,200 were from partial ejections. Fatal injuries from partial ejection can occur even to belted occupants,⁵⁷ when their head protrudes outside the window and strikes the ground in a rollover or strikes the striking object (e.g., pole or a taller vehicle hood) in a side impact. Window curtains that meet the oblique pole test will better protect against these partial ejections.

We are not supportive of maintaining both the 75-degree oblique pole test and the FMVSS No. 201 pole test in the standard, as suggested by Mr. Watson. While the inclusion of both tests could provide more assurance of occupant safety, we are concerned whether the test burdens are justified. Although we found in our testing that some air bag systems that met the FMVSS No. 201 pole test did not deploy the air bag in the agency's 75-degree oblique pole test, we do not expect the opposite trend from the adoption of this regulation. Vehicles will be subject to testing by IIHS in its side impact consumer information program, which conducts 90-degree MDB tests. Side air bag sensors will therefore be designed to sense such impact orientations. Further, even in the absence of the IIHS test, we believe that the use of two test dummies, two seating procedures and an oblique angle in the FMVSS No. 214 pole test will induce the use of sensor designs and mounting locations that will be sufficiently robust to detect both 75-degree and 90-degree impacts.

3. Positioning the Seat for the Test

A. Fore-and-Aft Seating Position

For the oblique pole test, the agency proposed to position the test dummies fore-and-aft along the vehicle seat track, according to the current FMVSS No. 214 seat positioning procedure, as opposed to the procedure specified in FMVSS No. 201. The proposed procedure would

⁵⁶ "Rollover Ejection Mitigation Using Inflatable Tubular Structures," Simula, *et al.*, 1998; "Status of NHTSA's Ejection Mitigation Research Program," Willke, *et al.*, ESV 2003.

⁵⁷ About 60 percent of the partial ejections occurred to belted occupants.

place the seat at the full-forward position for the 5th percentile female dummy and the mid-track position for the 50th percentile male dummy.

Public Citizen and Advocates supported NHTSA's proposed seating position for the dummies. They believed that these positions would assure that air bags installed to comply with the standard would provide a relatively broad zone of protection. While supporting the two proposed seating positions, Mr. Watson believed that NHTSA should also test with the seating position fully forward, mid-track, and fully rearward to ensure the widest restraint coverage and the most robust sensing technique.

DaimlerChrysler and the Alliance supported the mid-track seating position for the ES-2 dummy. However, the Alliance stated that the WorldSID test dummy should be positioned according to the seat track and seat back adjustment procedure based on a University of Michigan Transportation Research Institute (UMTRI) Seating Accommodation Model. The Alliance stated that the UMTRI model is based on a study of actual seating positions selected by drivers who are the same size as the 50th percentile adult male frontal dummy and the 5th percentile adult female frontal crash test dummy. In its comment, IIHS stated that the UMTRI seat position should be used for both the 5th female dummy and for the ES-2re 50th percentile dummy. IIHS believed that the UMTRI procedure is more representative of real world seating behavior, which IIHS stated is typically rearward of the proposed positions. IIHS stated that if the agency decides to use the mid-track position for the 50th percentile male dummy, the range of occupant sizes protected by the proposed head protection will not be as large as intended by the agency.

Nissan did not support the proposed seat positions for the pole test. It believed that the dummy in the proposed positions might be close enough to the A- or B-pillar that these structures would interfere with the dummy's head prior to contact with the pole. Nissan believes that this circumstance could result in reduced test repeatability, and it therefore recommended the seat positions used in the FMVSS No. 201 pole test procedure.

Ferrari objected to the proposed positioning procedure for the 50th percentile male dummy. Ferrari stated that using only the control that primarily moves the seat in the fore-and-aft direction, as proposed in the new procedure, changes the mid-point of the seating position from the current position.

Agency response: After carefully reviewing the comments on seating procedures, the agency decided to adopt the NPRM proposal on positioning the test dummies fore-and-aft along the vehicle seat track. We agree with commenters that stated these positions (full forward for the 5th percentile female dummy; mid-track for the 50th percentile male dummy) would assure that air bags installed to comply with the standard would provide a relatively broad zone of protection. While we also agree with Mr. Watson's suggestion that testing with the seat positioned in the full rearward position could provide even more coverage, we also had to maintain a level of practicability in establishing the requirements.

Positioning the dummy further rearward could present potential B-pillar interference and repeatability issues, such as those cited by Nissan. Neither the agency nor the commenter has data to support such a proposal at this time.

We were not persuaded by IIHS's suggestion of using the UMTRI seat track and seat back adjustment for the SID-IIIs and ES-2re dummies in the oblique pole test configuration. On February 23, 2004, NHTSA denied a petition for rulemaking to adopt the UMTRI procedure in FMVSS No. 214.⁵⁸ The agency concluded that there was a lack of evidence supporting the UMTRI procedure. IIHS noted in their FMVSS No. 214 comments that the UMTRI seating procedure typically positions both dummies rearward of the proposed positions. However, no data was provided to support the claim that the UMTRI position provided more coverage than that proposed by the NPRM. Furthermore, no data was provided to support that such a change in seating procedure would be practicable, repeatable, and result in measurable benefit. Therefore, we are not considering it for incorporation into FMVSS No. 214.

The Alliance's recommendation on how to seat the WorldSID dummy is out of scope for this rulemaking. As previously discussed, research will need to be conducted in conjunction with the federalization of that dummy.

In response to Nissan, we do not agree that the seating procedure would result in A- or B-pillar interference with the dummy's head prior to contact with the pole. We have not observed this in our crash tests to date. Further, no data was submitted to the agency to support this claim. Furthermore, our testing has shown that the oblique pole test procedure is repeatable. Accordingly, we do not agree it is necessary to adopt

the FMVSS No. 201 pole test seating procedure.

In response to Ferrari, this final rule adopts the specification of the new positioning procedure that only the control that primarily moves the seat in the fore-and-aft direction is used to position the seat along the seat track. This procedure is simpler than the current FMVSS No. 214 procedure, and produces more repeatable seat positioning of complex power seats than the current procedure. We also believe that the differences, if any, in seat placement along the seat track will be minimal. The new procedure was used successfully in NHTSA's 214 fleet testing program (see Section IV, *supra*).

B. Head Restraints

The Alliance and Honda requested clarification of the positioning of head restraints for all seating positions. In the proposed regulatory text, sections that involve seating the SID-IIIs dummy in the front and rear seats (proposed 8.3.2.2 and 8.3.3.2, respectively) state that any adjustable head restraint is to be positioned in the lowest and most forward position. However, sections that involve seating the ES-2re dummy in the front and rear seats (sections 8.3.1.2 and 8.3.4) state that any adjustable head restraint is to be positioned in the lowest and most forward position for the front seat, and in its highest position for the rear seat. The Alliance recommended that any adjustable head restraints be placed in the manufacturers' specified position, while Honda believes the head restraints should be positioned in its highest position, as currently required by FMVSS No. 214.

Agency response: We concur with the need for clarification of the proposed regulatory text pertaining to head restraint positioning. The agency's intent was to maintain the head restraint positioning currently used in the MDB test of FMVSS No. 214 for the ES-2re dummy (highest and most forward adjustment position) and to position the head restraint in the lowest and most forward position for the SID-IIIs dummy. Accordingly, we have revised the ES-2re regulatory text to reflect our intent. We were not persuaded by the Alliance's recommendation to adopt the manufacturer's specified position for head restraint adjustment. The highest position of adjustment has been used for the SID dummy in FMVSS No. 214 MDB tests for many years, and we do not anticipate any significant differences in head restraint interaction with the ES-2re dummy that would warrant a change in specification. Furthermore, the

Alliance did not provide a rationale for its requested change.

The final rule does, however, add clarification in the regulatory text for head restraint designs with adjustable backset when tested with the ES-2re dummy. Proposed paragraph S8.3.1.2 is amended to specify that an adjustable head restraint must be positioned to its highest and most forward adjustment position.

4. Impact Reference Line

S10.12.2 states that the test vehicle is propelled sideways so that its line of forward motion forms an angle of 285 (or 75) degrees (+/- 3 degrees) for the right (or left) side impact with the vehicle's longitudinal centerline. The angle is measured counterclockwise from the vehicle's positive X-axis. The impact reference line is aligned with the center line of the rigid pole surface, as viewed in the direction of vehicle motion, so that, when the vehicle-to-pole contact occurs, the center line contacts the vehicle area bounded by two vertical planes parallel to and 38 mm (1.5 inches) forward and aft of the impact reference line.

Ferrari commented that contact between the center line of the rigid pole surface and the vehicle does not represent the initial contact between the pole and the vehicle. Ferrari requested that the proposed test procedure be modified so that the 38 mm tolerance refers to the initial impact point rather than the contact point of the center line of the pole surface as viewed from the direction of the vehicle motion.

Agency response: Ferrari provided two schematics to illustrate its comments. (http://dmses.dot.gov/docimages/pdf92/338984_web.pdf) In the schematics, Ferrari erroneously interpreted the forward motion of the test vehicle relative to the pole and initial impact point. In order to achieve the proper impact configuration, the test vehicle is propelled sideways at an angle (285 degrees for right and 75 degree for left side impact) into the stationary pole, not perpendicular as shown in the schematics. To clarify the test set up, the agency has decided to include in the compliance test procedure a schematic depicting the impact configuration.

5. Test Attitude

The NPRM proposed to refine how the vehicle test attitude is determined. Currently, the vehicle attitude is defined by measurements made from the ground (a level surface) to a reference point placed on the vehicle body above each of the wheels. These measurements are made with the vehicle in the "as

⁵⁸ See 69 FR 8161.

delivered,” “fully loaded,” and “pre-test (or as tested)” conditions. The NPRM proposed that the method used to determine the test attitude be revised to align with that used in S13.3 of FMVSS No. 208. In that provision, a test attitude is determined based on door-sill angle measurements to control the vehicle’s pitch attitude.

The NPRM also proposed to define the vehicle’s roll attitude by a left to right angle measured along a fixed reference point at the front and rear of the vehicle at the vehicle longitudinal center plane. NHTSA proposed these changes because measuring the angles more directly will better facilitate, and more accurately determine, the vehicle attitudes than by use of the method in current S6.2 of FMVSS No. 214 (specifying test procedures for the MDB test). In the MDB test, the dummy and vehicle instrumentation, high-speed cameras, associated brackets and instrumentation umbilical lines that are added to the vehicle make it difficult sometimes to achieve the corridor between the as delivered and fully loaded attitudes, particularly at the right front position of the vehicle. The agency also requested comments on keeping the present method used to determine vehicle test attitude, but adding a ± 10 mm tolerance.

DaimlerChrysler and the Alliance commented that there was no proposed specification regarding the vehicle’s vertical position relative to ground. They believed that, for the MDB test, the resultant vehicle setup might not reproduce the intended relationship between the vehicle and MDB. The Alliance also stated that while the procedure would provide for measurement of vehicle pitch and roll attitude, it is not clear that this offers benefit with regard to execution of the test. The Alliance recommended that the current set procedure be retained with the following exception: in determining the fully loaded vehicle weight and attitude, there should be specifications on placing weights representing the necessary test dummies in the seating positions. Finally, the Alliance suggested that we provide direction on determining test attitude and ride height for vehicles equipped with dynamic suspension systems that adjust ride height based on vehicle velocity or that can be manually set by the driver for differing road conditions (e.g., off-road, luxury ride, etc.).

Agency response: The vehicle attitude specifications assure that proper attitude is attained prior to impact. As stated in the NPRM, the agency believed that measuring pitch and roll angles more directly and more accurately

determines the vehicle attitude than using the current method. The agency used the proposed method during the 214 fleet testing program conducted in support of this final rule. The test vehicles were loaded in accordance with S8.1, using instructions in the draft test procedure. Ballast representing the weight of the test device was placed in the seat to determine the “fully loaded” condition. The proposed method yielded the intended result of assuring proper attitude in the agency’s pole tests. For these reasons, the agency has decided to adopt the proposed revised method for the pole test.

For the MDB test, the agency agrees that a specification regarding the vehicle’s vertical position relative to ground is desirable. The agency has decided to maintain the present method used to determine vertical height measurements, but is adding a ± 10 mm tolerance. In addition, instructions to assure that conventional and dynamic suspensions are exercised prior to taking attitude measurements have been included in the agency’s test procedure.

Regarding the Alliance’s suggestion that there should be specifications on placing weights representing the necessary test dummies in the seating positions, NHTSA currently allows various forms of ballast (other than an actual dummy). We do not believe that instructions are needed regarding what ballast should be used or how the ballast should be placed on the seat for proper weight distribution. For our 214 fleet testing program, one test laboratory used a “ballast dummy” to attain the fully loaded condition, while another used sand bags. Both methods were acceptable, yielding valid results.

6. Rear Seat Pole Test

The NPRM proposed to apply the pole test to only the driver and front outboard passenger seats because years of conducting the optional pole test in FMVSS No. 201 have yielded substantial information about meeting pole test requirements for those seats, while far less information was known about the rear seat. The agency also believed that rear seat occupants make up a small percentage of the seriously injured occupants in side crashes. We also found it compelling that side air curtains generally cover both front and rear side window openings and thus would also afford some degree of head protection to rear seat occupants even in the absence of a test applying to the rear seat. We also recognized that applying the test to the rear seats would require at least twice as many tests per vehicle, increasing the cost and burden of the

rulemaking, with minimal assured benefit.

Consumers Union, Advocates, Public Citizen, and Mr. Watson expressed concern about not applying the test to the rear seat. The commenters believed that equivalent protection in side impacts should be provided to rear seat occupants. Advocates commented that either the agency must also apply the pole test to rear seats or should modify the current FMVSS No. 214 MDB so that it induces dynamic protection countermeasures for the rear seat occupants. Advocates and Public Citizen believed that an additional pole test would encourage manufacturers to install side air bags for rear occupants and improve protection for the elderly and children, who are often seated in the rear of the vehicle. Mr. Watson believed that air bag sensing arrangements may not be able to deploy the countermeasures for a variety of rear door impacts, and therefore recommended that the agency require an identical pole test for the rear seat occupant. Autoliv suggested possibly regulating only head impacts for rear seat occupants since few vehicles have been currently developed for rear seat thorax protection during a pole impact.

Agency response: We have decided against applying the pole test to the rear seating positions. As noted earlier in this preamble, rear seat safety is enhanced by this final rule in several ways. For the first time, a HIC criterion is adopted for rear seat occupants. In addition, use of the SID-IIIs (5th percentile adult female) test dummy in testing rear seats in the MDB test of FMVSS No. 214 (discussed later in this preamble) will assess the rear seat environment in protecting children, the elderly and small adults—a more vulnerable population than the mid-size adult male population—in rear seating positions in vehicle-to-vehicle crashes. The SID-IIIs dummy is more representative of rear seat occupants than SID, and the injury assessment reference values we will use with the dummy are set at levels that reflect the effect of aging on tolerance.

However, with specific regard to the pole test, a consideration of several factors leads us to decline to apply the pole test to rear seating positions. Directly applying the pole test to the rear seat is not necessary for the pole test to enhance rear seat safety. Air curtains cover both front and rear side window openings, and are tethered to the A- and C-pillars of vehicles. Curtains tethered to the A- and C-pillars will be large enough to cover both front and rear side window openings and will

afford protection to both front and rear seat occupants in side impacts.

We believe that manufacturers will increasingly install air curtains in their vehicles because air curtains can potentially be used as a countermeasure in preventing ejection in rollovers. (“NHTSA Vehicle Safety Rulemaking Priorities and Supporting Research: 2003–2006,” July 2003, Docket 15505.) NHTSA has announced that it is developing a proposal for an ejection mitigation containment requirement.⁵⁹ NHTSA believes that side curtains installed pursuant to FMVSS No. 214’s pole test could readily be developed to satisfy the desired properties of a countermeasure. (NHTSA report “Initiatives to Address the Mitigation of Rollovers,” *supra*.) We believe that manufacturers will install curtains in increasing numbers of vehicles in response to this final rule, the voluntary commitment, and in anticipation of NHTSA’s ejection mitigation rulemaking. The curtains will provide head protection to front and rear seat occupants in side impacts.

We have also decided against applying the pole test to rear seating positions because, as noted in the NPRM, according to 1999 and 2000 Fatality Analysis Reporting System (FARS) data, the front outboard seating positions account for 89.2 percent of total fatalities and 88.8 percent of total injured occupants in passenger cars, and 86.6 percent and 87.6 percent of total fatalities and total injured occupants in LTVs. While these are for all crash conditions, the percentages for side impacts with narrow objects are similar. In nearside crashes, rear occupants make up 7.3 percent, 10.2 percent and 4.4 percent of seriously injured persons in crashes with passenger cars, LTVs and narrow objects, respectively. As stated in the NPRM (69 FR 28011), the 1997–2001 NASS CDS annualized fatality distribution for rear outboard occupants indicates there were 22 fatalities caused by a vehicle-to-pole side crash, 7 of which were due to head injury.

In addition, we are not applying the pole test to rear positions out of a concern that more needs to be known about seat-mounted SIABs in rear seating positions. Currently, almost no vehicle has seat-mounted air bag systems in rear seats. If a pole test were applied to the rear seat, seat-mounted SIABs might emerge to meet chest protection requirements. At this time,

⁵⁹ Additionally, Sec. 10301 of SAFETEA-LU requires the Secretary to issue by October 1, 2009 an ejection mitigation final rule reducing complete and partial ejections of occupants from outboard seating positions (49 U.S.C. 30128(c)(1)).

we have limited information about the performance of rear seat-mounted air bag systems in meeting the TWG performance guidelines. We believe that more has to be learned about the risk to children in rear seating positions before we proceed with adopting a requirement that will encourage the installation of seat-mounted SIABs as a countermeasure to that requirement.

7. Door Closed

FMVSS No. 214 currently prohibits any side door that is struck by the MDB from separating totally from the vehicle (currently in S5.3.1 of the standard). The standard also requires any door (including a rear hatchback or tailgate) that is not struck by the moving deformable barrier to meet the following requirements: the door shall not disengage from the latched position; the latch shall not separate from the striker, and the hinge components shall not separate from each other or from their attachment to the vehicle; and neither the latch nor the hinge systems of the door shall pull out of their anchorages. The NPRM proposed to apply the same door separation/opening prohibitions to vehicles tested in the vehicle-to-pole tests.

The only comments on the proposal were from Advocates and Public Citizen, which opposed the proposal. The commenters believed that, to improve “anti-ejection countermeasures” the standard should not permit struck doors to become unlatched in the pole test.

Agency response: This final rule does not make a change from the proposal. NHTSA has not observed the struck door unlatching in the optional pole test of FMVSS No. 201, or in the agency’s vehicle pole tests discussed in the technical report on the test program. The test data indicate that vehicle manufacturers are already designing their vehicles such that the struck door will not unlatch during the pole test.

8. FMVSS No. 201 Pole Test

FMVSS No. 201 specifies an optional 90-degree, 29 km/h (18 mph) pole test using a SID-H3 driver dummy (1000 HIC₃₆ test criterion). The NPRM proposed to amend FMVSS No. 201 to exclude vehicles certified to FMVSS No. 214’s oblique 32 km/h (20 mph) pole test from the 90-degree, 29 km/h (18 mph) pole test in FMVSS No. 201. The agency believed that a vehicle that met the oblique 32 km/h (20 mph) pole test would also meet FMVSS No. 201’s 90-degree 29 km/h (18 mph) test. Thus, the agency proposed to eliminate the FMVSS No. 201 optional pole test for vehicles certified to the FMVSS No. 214

oblique pole test, to delete an unnecessary test burden on manufacturers.

Advocates, AIAM and the Alliance supported the agency’s proposal to exclude vehicles meeting an FMVSS No. 214 pole test from FMVSS No. 201’s 90-degree, 29 km/h (18 mph) pole test. Advocates agreed with the NPRM that a vehicle meeting the proposed pole test would also meet the optional pole test of FMVSS No. 201.

Honda suggested a further exclusion of vehicles from a requirement of FMVSS No. 201. Honda asked NHTSA to consider excluding vehicles from the armrest requirements of S5.5.1 if the vehicles comply with the oblique pole test of FMVSS No. 214. Honda believes that: “If a vehicle meets the proposed requirements, that compliance should supercede the armrest requirements of FMVSS 201.”⁶⁰

Agency response: The FMVSS No. 214 oblique pole test encompasses and goes beyond the FMVSS No. 201 pole crash test and thus renders unnecessary the latter test. Seat-mounted side impact air bags that deploy into an area far enough forward to cushion a 5th percentile female dummy’s head in a 32 km/h (20 mph) oblique impact are also likely to protect a 50th percentile male’s head in a perpendicular one. Similarly, an air curtain tethered to the A- and C-pillars that meets an oblique crash test is also likely to provide coverage in a perpendicular crash. Accordingly, this final rule adopts the proposed amendment to FMVSS No. 201. It should be noted that targets near the stowed HPS are still subject to the head form test of FMVSS No. 201, conducted at the 19.3 km/h (12 mph) test speed specified in that standard.

This final rule does not make Honda’s suggested deletion of the arm rest requirements of FMVSS No. 201. The suggested change was not proposed in the NPRM.

9. Quasi Static Test

The Alliance, AIAM, Lotus, Maserati, and Ferrari suggested that NHTSA delete the quasi-static test requirements from FMVSS No. 214 if the pole test is

⁶⁰ FMVSS No. 201 requires each armrest to meet one of the following: (a) Be constructed with energy-absorbing material and deflect or collapse laterally at least 50 mm without permitting contact with the underlying rigid material; (b) be constructed with energy-absorbing material that deflects or collapses to within 32 mm of a rigid test panel surface without permitting contact with any rigid material, and the rigid material between 13 and 32 mm from the panel surface must have a minimum vertical height of not less than 25 mm; or (c) along not less than 50 continuous mm of its length, the armrest shall, when measured vertically in side elevation, provide at least 55 mm of coverage within the pelvic impact area.

adopted. (A summary of FMVSS No. 214's current requirements is in Appendix B of this preamble.) The quasi-static requirements limit the extent to which the side door structure of a vehicle is pushed into the passenger compartment during a side impact. The standard requires each side door to resist crush forces that are applied by a piston pressing a 300 mm (12 inch) steel cylinder against the door's outer surface in a laboratory test. Since the requirement became effective in 1973, vehicle manufacturers have generally chosen to meet the requirement by reinforcing the side doors with metal beams. Ferrari stated, "The purpose of the static door crush resistance test in the existing FMVSS No. 214 is to guarantee the ability of the vehicle to provide some kind of protection in a side impact against a narrow object." Commenters believed that the pole test would assess the same performance, making the quasi-static test redundant and burdensome.

In contrast, Public Citizen recommended that the agency evaluate the potential for adding an intrusion limit to the proposed pole test, in addition to the dummy injury criteria. The suggested requirement would regulate the amount of pole intrusion into the occupant survival space. Public Citizen believes that the level of intrusion into the occupant space is closely correlated with the level of occupant injury risk.

Agency response: This final rule does not remove the quasi-static test from FMVSS No. 214. Removing the test is beyond the scope of the NPRM. Further, there is a safety need for the test. To meet the quasi-static test, vehicle manufacturers have equipped vehicles with side door beams which transmit the force sideways to the struck vehicle, thus reducing the amount of intrusion toward the occupant and slowing down the rate of that intrusion.⁶¹ NHTSA found that the side door beams were 14 percent effective in reducing fatality risk for nearside and farside occupants in single-vehicle side impacts.⁶² When this group of crashes was further limited to impacts with a single fixed object, fatality reduction was 23 percent. The agency believes that the beam acts like an internal guard to allow a car to slide past a pole or tree, with a longer, shallower crush pattern on the car.

⁶¹ Kahane, C.J., An Evaluation of Side Impact Crash, FMVSS 214 TTI(d) Improvements and Side air Bags, NHTSA Technical Report No. DOT HS 810 748, Washington, DC 2007.

⁶² Kahane, C.J., An Evaluation of Side Structure Improvements in Response to Federal Motor Vehicle Safety Standard 214, NHTSA Technical Report No. DOT HS 806 314, Washington, DC 1982.

Beams were also found to be effective in lower-speed multivehicle crashes, reducing the risk of nonfatal injuries. Kahane (2007). The quasi-static test is needed, particularly for doors of the vehicle that are not impacted by the pole in the oblique pole test (such as the rear compartment doors).

This final rule does not add an intrusion limit to the pole test requirements adopted today. Adding an intrusion limit is beyond the scope of the NPRM. Further, not enough information is known at this time about the need for an intrusion limit, given that the injury criteria of the pole test act to limit the risk of injury to an occupant.

10. Vehicle Exclusions

The agency proposed subjecting vehicles with a GVWR of 4,536 kg (10,000 lb) or less to the oblique pole test, with certain exceptions. The agency proposed excluding: motor homes, tow trucks, dump trucks, ambulances and other emergency rescue/medical vehicles (including vehicles with fire-fighting equipment), vehicles equipped with wheelchair lifts, vehicles with raised or altered roof designs, and vehicles which have no doors, or exclusively have doors that are designed to be easily attached or removed so that the vehicle can be operated without doors. The agency believed that many vehicles within these categories tend to have unusual side structures that may not be suitable for pole testing or have features that could pose practicability problems in meeting the test. Comments were requested on the need to exclude other types of vehicles from the pole test, such as convertibles that lack a roof structure enabling the installation of an air curtain.

The proposed exclusions are adopted, except to the extent discussed below in this section.

i. GVWR. Advocates and Public Citizen supported the inclusion of vehicles with a GVWR of 4,536 kg (10,000 lb) or less, while the Alliance believed that vehicles above a GVWR of 3,855 kg (8,500 lb) should be excluded. The Alliance believed that the agency did not show that the requirement would be practicable for vehicles with a GVWR above 3,855 kg (8,500 lb), and also stated that a safety need for applying the pole test to those vehicles has not been shown.

Agency response: After consideration of the comments and test data from the NHTSA 214 fleet testing program (see Section IV of this preamble, *supra*) and other information, we are adopting the proposal that the performance

requirements for the oblique pole test should apply to all vehicles with a GVWR of 4,536 kg (10,000 lb) or less.

One of the vehicle models the agency tested in its vehicle research program had a 4,082 kg (9,000 lb) GVWR. This was a model year 2005 Dodge Ram 2500 equipped with side curtain air bags. The agency tested this vehicle in two vehicle-to-pole tests with the ES-2re dummy. In the first test, the side curtain air bags did not deploy, and consequently, the ES-2re dummy resulted in high injury measures, including a HIC of 5,748, 47 mm of rib deflection, and a lower spine acceleration of 86 g. The test results demonstrated a need for improved sensors and side impact protection for the occupants of this vehicle. In the second test, using the same vehicle model, the side curtain air bags were deployed remotely at 12 msec,⁶³ and the resulting HIC value was 331. The results of this test showed that the deployment of the side curtain air bag resulted in significant HIC reductions for the ES-2re dummy (from 5,748 to 331). The ES-2re dummy was chosen for use in the agency's testing since it is likely to be the most challenging pole test configuration of the two required. The ES-2re is equipped with more instrumentation in the abdomen and thorax, and its larger mass requires more energy management by the restraint system. Although the rib deflections and abdominal force measurements for the ES-2re exceeded the IARVs, the vehicle was not equipped with a thorax side air bag. We believe that these measures would be improved with a thorax side air bag, and possible structural enhancements.

The agency does not agree with the Alliance that vehicles over 3,855 kg (8,500 lb) GVWR should be excluded from the pole test. In side impacts with poles and trees, the objects struck are typically taller than the striking vehicle. There are no indications of any lesser safety need for side impact protection for these vehicles. These vehicles are driven on the same roads and at the same times as other LTVs, and are thus subject to the same safety risks as other LTVs. NHTSA is not aware of any special characteristic of these vehicles that would reduce such risks.⁶⁴ In addition, the Alliance did not suggest

⁶³ Since the side crash sensor was unable to deploy the air bags in the oblique pole test configuration in the first test, the side curtain air bags were deployed remotely.

⁶⁴ Moreover, since the industry's voluntary commitment to install side air bags in vehicles does not apply to vehicles with a GVWR greater than 3,855 kg (8,500 lb), applying the pole test to the vehicles assures that SIABs will be provided.

why the pole test might be practicable for vehicles with lower GVWR, but not for vehicles with a GVWR above 3,855 kg (8,500 lb). We believe manufacturers can employ comparable restraint systems and countermeasure strategies to comply with the oblique pole test.

However, the test of the Dodge Ram 2500 (9,000 lb GVWR) indicated that vehicles with a GVWR greater than 3,855 kg (8,500 lb) may need more time than other vehicles to meet the pole test requirements, since the vehicles have never been regulated under FMVSS No. 214's dynamic requirements and are not subject to the industry's voluntary commitment to install side air bags. These vehicles may need more structural enhancements than other vehicles since they will be newly subject to side crash requirements, and a demanding pole test at that. Accordingly, this final rule provides vehicles with a GVWR greater than 3,855 kg (8,500 lb) until the last year of the phase-in to meet the pole test requirements.

ii. Convertibles. The Alliance, AIAM, Nissan, DaimlerChrysler and Lotus recommended the exclusion of convertible vehicles from the pole test. The Alliance stated that we did not demonstrate it is practicable to implement countermeasures, while meeting the TWG OOP guidelines. It also believed that convertible vehicles should be excluded from all requirements because the lack of roof structure affects the overall response of a vehicle in a pole test, not just the HIC response.

AIAM believed that the inherent design constraints of convertibles prevent the compliance of the proposed pole test. Similarly, Nissan believed that convertibles lack the structural components necessary to store and deploy a curtain air bag and that these vehicles should be excluded from the HIC response requirement in the pole test. DaimlerChrysler believed that convertibles should be excluded because, the commenter stated, it is not practicable within the architectural limitations of convertibles to provide the supplemental structure to the vehicle to replace what the roof and roof rail can contribute in sedans and coupes to reduce penetration by the pole into the occupant compartment. Lotus commented that the lightweight performance convertible type vehicle would not be able to comply with the pole test requirements without the introduction of some new, and as yet unknown, technology.

Autoliv commented that it is currently working on developing a restraint system to protect occupants in

a pole impact for applications such as a convertible. Autoliv stated that the systems do not, however, address the structural challenges that may be involved in applying the pole test requirement to all vehicles that lack a roof structure.

Agency response: After careful consideration of the comments, NHTSA has decided against excluding convertibles from the pole test requirements. In our comparative analysis between convertibles and all other passenger cars in side impact crashes with fixed objects, it was found that 11.3 percent of convertible fatalities are from single vehicle side impacts into poles/trees, compared to 6.5 percent of other passenger car fatalities from single vehicle side impacts into poles/trees. The fatality rate⁶⁵ from single vehicle side impacts into poles/trees is 9.64 for convertibles, and 6.12 for all other passenger cars. When specifically looking at pole/tree fatality rates, convertibles are 58 percent higher than all other passenger cars. In general, NHTSA's crash data indicate that convertibles have higher rates of fatalities in run-off-the-road type crashes, such as single vehicle side impacts, rollovers, etc. Consequently, requiring enhanced protection against tree and pole side impacts will be paramount in improving the safety of these vehicles.

We have also observed head/thorax countermeasures that are effective and practicable for installation in convertible body types. While we agree with Nissan that roof-rail design air curtains may not be practicable to deploy and store in a convertible vehicle, we do believe that head/thorax air bag systems, or even door-mounted inflatable curtains, as introduced in the 2006 model year Volvo C70 convertible, have merit. In our 214 fleet testing program, we included two convertible vehicle models in our crash test matrix. These were the 2005 model year Saab 9-3 convertible and 2005 model year Volkswagen Beetle. Both vehicle models were tested in the oblique pole test with the ES-2re dummy.⁶⁶ In each case, the

⁶⁵ Data source: FARS 1999-2003. Model years 1998-2002 were used. Total registration years (in millions) were 140.8 for all other passenger cars and 4.7 for convertibles. The fatalities per million registration years in single vehicle side crashes were 11.32 for all other passenger cars and 16.71 for convertibles. The fatalities per million registration years in single vehicle side "pole/tree" crashes were 6.12 for all other passenger cars and 9.64 for convertibles.

⁶⁶ The ES-2re dummy was chosen for use in the agency's testing since it is likely to be more challenging pole test configuration than the SID-11s test. We determined that it would be more difficult for seat-mounted systems to meet the performance

vehicle was able to meet the requirements of this final rule and demonstrated that compliance with the requirements for both head and chest injury criteria is practicable. For the Saab, HIC was 254, chest deflection was 40 mm, abdominal force was 841 N, and pelvic force was 2914 N. For the Beetle, HIC was 315, chest deflection was 37 mm, abdominal force was 1018 N, and pelvic force was 3815 N.⁶⁷ The Saab 9-3 and Volkswagen Beetle demonstrated practicability along a range of the convertible cost spectrum. This fact, combined with the higher fatality risk mentioned earlier, leads NHTSA to believe that head/thorax countermeasures will be at least as cost-effective for convertibles as they are for other vehicles. We are not persuaded that solutions are unknown or not available to convertibles as a whole, as suggested by Lotus.

In response to the Alliance's concern about meeting the TWG OOP guidelines, we note that vehicle manufacturers for both the Saab 9-3 and the VW Beetle reported that they comply with the TWG OOP guidelines according to our 2005 Buying a Safer Car information. Therefore, we believe that the agency has demonstrated practicability of the pole test and of meeting the head and chest requirements. Our tests have shown that the lack of a roof structure in the pole test was not an insurmountable design obstacle for providing improved side crash protection. Therefore, we conclude that HIC, and all other applicable injury measures, should be regulated in this test.

iii. Proximity to a Door

Maserati and Ferrari noted that under the current S3(e)(1) of FMVSS No. 214's quasi-static test, a vehicle need not meet the static test requirements for any side door located so that no point on a 10-inch horizontal longitudinal line passing through and bisected by the H-point of a manikin placed in any seat falls within the transverse, horizontal projection of the door's opening. The commenters believed that under that provision, a vehicle is excluded from the static test requirement if its side door is located so that the H-point of the manikin is below the sill of the vehicle. Ferrari stated, "if a vehicle is exempt

criteria using the ES-2 than when tested with the SID-11s. The ES-2re is equipped with more instrumentation in the abdomen and thorax, and its larger mass requires more energy management by the restraint system.

⁶⁷ Injury criteria are: HIC 1000, chest deflection 44 mm, abdominal force 2500 N, and pelvic force 6000 N.

under current S3(e), it should likewise be exempt from the proposed pole test.”

Agency response: We do not agree with Maserati and Ferrari that an exclusion from the pole test requirements is appropriate if the H-point of a manikin placed in any seat is below the sill of the vehicle, and thus does not fall “within the transverse, horizontal projection of the door’s opening.” The agency’s rationale for the exclusion in question from the static test does not apply to the pole test.

In the June 14, 1991 FMVSS No. 214 final rule that adopted the exclusion (56 FR 27427), the agency stated that there was little safety benefit from having a side door beam requirement for those door openings that are unlikely to have occupants sitting near them (i.e., within 10 inches of the door opening). In the static test, the loading device is centered on the door opening, and a load is applied until a specified load is achieved. The door must prevent intrusion of the door structure. If no occupant will be seated within 10 inches of the door opening, the requirement limiting intrusion to 10 inches is unnecessary. (As to whether the exclusion should apply to situations where the manikin is seated within 10 inches of the door, but below the sill, will not be addressed today.)

In the oblique pole test, the pole is aligned with the head CG of the seated dummy. An occupant who is seated “outboard” next to a door but below the transverse, horizontal projection of the door’s opening could suffer injuries, especially head injury, in a tree/pole impact if side air bags or other countermeasures were not installed. Accordingly, the pole test requirement will yield meaningful results for the vehicles in question, and the exclusion will not be extended as requested.

iv. Removable Doors

The Alliance and DaimlerChrysler believed that vehicles without doors or easily removable doors, now excluded from the MDB and quasi-static tests under S2(c) and S3(e)(4) of the current standard, respectively, should also be excluded from the pole test since the lack of door structure makes meeting the test requirements impracticable. On the other hand, Advocates objected to excluding vehicles with no or removable doors since, the commenter believed, the exclusion would allow manufacturers to avoid providing adequate side impact protection.

Agency response: We agree with excluding vehicles without doors or easily removable doors from the oblique pole test since the lack of door structure makes meeting the test requirements

impracticable, as suggested by DaimlerChrysler. No data were provided by Advocates, or other commenters, to suggest that there are engineering solutions or countermeasures to meet the dynamic pole test requirements for vehicles without doors or easily removable doors. We believe that applying the pole test to those vehicles would effectively eliminate them from the marketplace.

v. Vehicles With Partitions

NTEA recommended an additional exclusion of vehicles equipped with a partition behind the front seat area. NTEA believed that “a bulkhead or partition will almost certainly invalidate any chassis manufacturer’s compliance statement that may be available for a vehicle equipped with side impact protection such as a side curtain air bag.”

Agency response: We do not agree with an exclusion of partition-equipped vehicles. We believe the exclusion is too broad and could encompass more vehicles than necessary. NTEA noted that the affected vehicles typically include panel vans with a bulkhead to separate the front seat occupants from bulk cargo placed in the rear, or buses with a partition separating the bus driver from the rest of the passenger compartment. We note that the vehicles also include police vehicles, taxis, and limousines. Although we acknowledge that a bulkhead or partition installed by a second-stage manufacturer or alterer is incompatible with some current side curtain air bag systems tethered from the A- to C-pillars, second-stage manufacturers and alterers have alternatives, discussed below, that would enable them to certify to the pole test.

We believe that incomplete vehicles and completed cargo vans will be available with seat-mounted or door-mounted head/thorax air bag systems. Not all cargo vans will have side curtain air bag systems that are tethered from the A- to the C-pillar. Cargo van manufacturers are not likely to install A- to C-pillar side curtain air bag systems since these vehicles have no rear seats or rear window openings. (Likewise, small bus manufacturers are not likely to extend side air curtains the full length of the bus.) Since the pole test is only applied to the driver and right front passenger seating locations, incomplete cargo van manufacturers will likely certify the vehicles to the pole test using seat-mounted SIABs (or may develop air curtain technology that involve designs other than tethering the curtain to the A- and C-pillars). A partition can be installed in these

vehicles without invalidating the incomplete manufacturer’s compliance statement.

We also note that this final rule provides alterers and multi stage vehicle manufacturers an extra year of lead time to accommodate any necessary changes.⁶⁸ Between now and that date, they can work with manufacturers of incomplete and complete vehicles to develop seat-mounted SIABs and other technologies that would enable them to install the life-saving devices in vehicles that have partitions.

vi. Wheelchair Restraints

NMEDA believed that we should exclude vehicles with wheelchair restraints that allow the wheelchair to be used as a designated seating position. NMEDA noted “many wheelchair users drive their vehicles from a wheelchair or ride in the front row passenger position, again in a wheelchair. In these cases, the wheelchair is secured to the vehicle floor, and the occupant is restrained with a type 2 seat belt assembly.”

Agency response: An exclusion of any vehicle with wheelchair restraints is overly broad. However, we agree that vehicles in which a wheelchair is to be used in place of the driver’s or right front passenger’s seating position should be excluded from the pole test for that seating position. The vehicles are excluded out of practicability concerns. If a seat that had seat-mounted SIABs were removed from a front outboard seating position, the vehicle would no longer have the countermeasure installed to meet the pole test. Installing a complying air curtain in these vehicles is likely beyond the capabilities of most small businesses modifying the vehicle. Even if the vehicle were originally manufactured with an air curtain, a vehicle tested to the oblique pole test with the test dummy in a wheelchair instead of the OEM driver or passenger seat might not meet the test requirements. Accordingly, vehicles in which the seat for the driver or right front passenger has been removed and wheelchair restraints installed in place of the seat are excluded from meeting the oblique pole test at that removed seating position.

⁶⁸This accords with the amendments set forth in the agency’s final rule on “Vehicles Built in Two or More Stages,” 70 FR 7414, February 14, 2005, Docket 5673. The February 14, 2005 final rule also added a new process under which intermediate and final-stage manufacturers and alterers can obtain temporary exemptions from dynamic performance requirements (49 CFR part 555).

vii. Altered (Modified) Roof or Lowered Floor

The agency proposed excluding vehicles with altered or raised roof designs from the pole test, and proposed using the definitions for “altered roof” and “raised roof” set forth in FMVSS No. 216, “Roof crush resistance.”⁶⁹

NMEDA suggested that vehicles with altered or raised roofs should be excluded from both the HIC and thoracic requirements because, the commenter believed, side air bag systems may have to be disabled to accommodate the raised/altered roof conversion. Similarly, the commenter believed that modifiers lowering the floor by modifying the SIAB sensor system as originally installed would also have an extremely difficult time to certify.

Agency response: We agree that vehicles that have had the roof rail or floor rail modified should be excluded from the pole test.⁷⁰ The vehicles are excluded out of practicability concerns, because roof rails and floor rails are typically integral parts of side impact protection systems. Modifying the roof or floor rail structures may affect the vehicle’s performance in meeting the oblique pole test requirements.

This final rule slightly expands the proposed definition of “altered roof,” because the FMVSS No. 216 definition was too narrow to meet the intent of the agency in excluding vehicles with altered roof rails. The proposed definition of altered roof (from FMVSS No. 216) only applied to a replacement roof that is higher than the original roof. We have modified the definition such that it is not incumbent on the replacement roof being higher than the original roof. There would be practicability issues in meeting the pole test for entities modifying the original roof rails of a vehicle even if the replacement roof were not higher than

the original roof. In addition, if the original roof rail were modified, there would also be practicability problems for entities using glazing materials in the replacement roof. Thus, unlike the FMVSS No. 216 definition, the FMVSS No. 214 definition does not exclude from the definition replacement roofs on vehicles whose original roof has been replaced by a roof that consists of glazing materials. This final rule also excludes on practicability grounds vehicles that have had their original roof rails removed and not replaced, i.e., as in the conversion of a hardtop vehicle to a convertible. Entities involved in such conversions are usually small businesses. The FMVSS No. 214 definition is changed to “modified roof” to distinguish it from the FMVSS No. 216 definition of altered roof.

viii. 6-Way Seats

NMEDA stated that mobility industry companies commonly replace front row seats with extended travel seat bases (“6-way seats”) to facilitate vehicle access. It believed that because the modified seat bases are generally less stable than the original seats, the pole test would result in higher HIC values in vehicles with extended movement seating systems than in vehicles with OEM seat bases. NMEDA thus recommended that we exclude vehicles with extended travel seating systems installed as a part of a second-stage manufacturing process or by a vehicle alterer.

Agency response: We have decided that vehicles with extended travel seat bases and other seating systems designed to facilitate vehicle access are not excluded from this final rule. NMEDA provided no data to support its assertion that a modified seat base would necessarily cause extended movement and higher HIC values in the required tests. Further, no explanation was provided as to why these seat bases cannot be built structurally comparable to the original seat. We do not believe that providing additional reinforcements to secure the seat is an insurmountable engineering task. If higher HIC values are occurring, that supports our belief that better designs are needed for occupants of these vehicles.

ix. Multistage Manufacturers

NTEA suggested that the final rule exclude “vehicles built in two or more stages that are equipped with a cargo carrying, load bearing or work-performing body or equipment.” The commenter stated that its members typically certify that their vehicles meet dynamic testing standards by “using so-

called ‘pass-through’ compliance.” NTEA is concerned that chassis manufacturers “may state that subsequent stage manufacturers are unable to do anything in the vicinity of” side curtain air bags or head bags.

The commenter also believed that there are no viable alternatives available to its members to demonstrate compliance other than by using pass-through compliance. NTEA stated that its members cannot certify vehicles based on engineering analyses because its members do not have the necessary level of experience with a new requirement of this nature, or previous crash test data, which NTEA believed are needed for an engineering analyses. NTEA stated that computer modeling is unavailable because the commenter believed it would be very expensive and not widely available to its members. The commenter stated that consortium dynamic testing is unavailable because the FMVSS No. 214 tests “are vehicle specific, [so] even minor trim differences in a single model could produce significantly different test results, let alone varying chassis and body combinations.” With regard to actual crash testing, NTEA stated: “It would be a practical impossibility for these companies to test each of these configurations to sell the one or two of each configuration that have been ordered by a customer.”

Agency response: NHTSA declines NTEA’s request to exclude from the pole test vehicles built in two or more stages that are equipped with a cargo carrying, load bearing or work-performing body or equipment. We do not believe that there is a need for a blanket exclusion of these vehicles. NTEA was concerned that incomplete vehicle manufacturers “may state that subsequent stage manufacturers are unable to do anything in the vicinity of” side curtain air bags or head bags. We believe that incomplete vehicle manufacturers will accommodate the needs of final-stage manufacturers to produce the vehicles. Chassis-cabs, a type of incomplete vehicle often acquired by final-stage manufacturers for manufacturing vehicles, have a significant portion of the occupant compartment completed. Chassis-cab manufacturers will likely produce incomplete vehicles with seat- or roof-mounted head/thorax air bag systems already installed. As long as the final-stage manufacturer meets the conditions of the incomplete vehicle document (and NTEA has not shown that final stage manufacturers will not be able to meet those conditions) the manufacturers may rely on the incomplete vehicle manufacturer’s

⁶⁹ FMVSS No. 216 defines “altered roof” as: “the replacement roof on a motor vehicle whose original roof has been removed, in part or in total, and replaced by a roof that is higher than the original roof. The replacement roof on a motor vehicle whose original roof has been replaced, in whole or in part, by a roof that consists of glazing materials, such as those in T-tops and sunroofs, and is located at the level of the original roof, is not considered to be an altered roof.” FMVSS No. 216 states: “Raised roof means, with respect to a roof which includes an area that protrudes above the surrounding exterior roof structure, that protruding area of the roof.”

⁷⁰ Vehicles with lowered floors are currently not excluded from the MDB test. Alterers and multistage manufacturers have been certifying their vehicles with lowered floors to the MDB test since 1998. Given the practicability of meeting the current MDB test, this final rule does not exclude lowered floor vehicles from the applicability of the MDB test adopted today.

certification and pass it through when certifying the completed vehicle.⁷¹

To the degree that final stage manufacturers must certify the compliance of their vehicles other than by using “pass-through” certification, we have provided these manufacturers until September 1, 2014 to work with manufacturers of incomplete vehicles, seating systems and SIABs to develop systems that will enable them to certify to FMVSS No. 214’s pole test. They can obtain seat-mounted SIABs and work with the suppliers, individually or as a consortium, to develop the information to install the seat-mounted systems in their vehicles. Because a wholesale exclusion of vehicles built in two or more stages that are equipped with a cargo carrying, load bearing or work-performing body or equipment has not been justified, we are not adopting an across-the-board exclusion of these vehicles.

x. Other Issues

The NPRM proposed excluding tow trucks and dump trucks from the pole test. NTEA commented that it was not aware of any dump trucks or tow trucks with GVWRs of 4,536 kg (10,000 lb) or less, so the vehicles would be excluded from the pole test based on the GVWR of the vehicles. Considering this information, the express exclusion is unnecessary, and we have removed it from the regulatory text. (For that reason, we have also removed the express exclusion from the section excluding vehicles from the MDB test requirements.)

11. Practicability

The Alliance believed that the agency did not demonstrate that attaining the IARVs would be practicable. The commenter stated, “Based on the information provided to support the NPRM, the agency has not identified one single vehicle that has met all of the proposed injury criteria in all of the proposed tests. Indeed, no one single vehicle has been subject to the entire suite of proposed crash tests. Therefore, the practicability of the proposed rule has not been demonstrated.”

NHTSA disagrees with the commenter’s view. In our test program, the Subaru Forester and the Honda CRV met the performance criteria for the SID–IIs dummy. The Honda Accord and VW Jetta almost met all the IARVs when tested with the SID–IIs dummy. The

Accord and Jetta had relatively low values for HIC and lower spine acceleration, and did not meet only the pelvic force criterion. The Honda Accord, VW Jetta, VW Beetle convertible, and Saab 9–3 convertible met the performance criteria for the ES–2re.

It is not surprising that the vehicles we tested did not meet the IARVs for both the SID–IIs and the ES–2re, because the oblique pole test was developed to induce improvements that would protect more occupants in more crash situations than current vehicles. NHTSA need not demonstrate that any current vehicle meets all the new requirements to show that an FMVSS will be practicable within the meaning of the Safety Act when fully implemented. A determination of practicability calls for an exercise in judgment by the agency, based on information about the performance of current designs and the likely effect of design improvements and new technologies on performance.

The fact that no current designs met the requirements when tested with both the SID–IIs and the ES–2re does not show the requirements will not be practicable, but it does require the agency to use its judgment carefully to ensure that the new requirements will be practicable within the lead time provided. In this case, we have ensured that the provided lead time and phase-in schedule assures that manufacturers can make long range plans for improved sensor designs, SIABs and arm rests to meet the IARVs for both test dummies. The test results from our 2005 test program show that some SIABs performed well with the SID–IIs, while others performed well with the ES–2re. We believe that current SIAB systems can be redesigned and implemented to provide occupant protection to the populations represented by both the SID–IIs and the ES–2re test dummies. For example, some window curtains adequately protect the head of the mid-size male dummy but may need to be widened and lengthened to ensure that the head of the SID–IIs is cushioned at the forward edge of the curtain. Some vehicles may need to use a seat-mounted SIAB (existing technology), in addition to a curtain, to meet the thoracic, abdominal and/or pelvic injury criteria for both dummies. We believe that vehicle manufacturers are capable of making these and other improvements to SIAB systems.

Manufacturers have made steady and notable progress in developing, improving and implementing SIABs. To illustrate, in 1998, only 0.04% of passenger cars sold in the U.S. had head

side air bag systems. In 2002, 22% of passenger cars were so equipped, and by 2009, under the voluntary commitment, manufacturers have projected that 100% of passenger vehicles will have head side air bag systems. Based on the vast knowledge that manufacturers have been able to gain in developing and implementing side air bag technologies, we are confident that manufacturers will be able to make the improvements to current systems that will enable the systems to meet the upgraded FMVSS No. 214 requirements adopted today.

12. International Harmonization

The Australian government was concerned that NHTSA’s side impact proposal would forestall the outcome of deliberations of the International Harmonized Research Activities (IHRA) Side Impact Working Group (SIWG) regarding a side impact pole test procedure, and the dummies used in the test.⁷² Our decisions today should not hamper the potential for global harmonization of side impact regulations.

Today’s final rule is consistent with NHTSA’s policy goal of harmonizing with non-U.S. safety requirements except to the extent needed to address safety problems here in the U.S. We noted in the NPRM that, worldwide, there are numerous countries that have side impact protection requirements or governmental or non-governmental side impact consumer information programs. While these side impact programs are similar to those of the U.S., the safety need addressed by those programs is different from the side impact safety need in the U.S., due in large part to fleet differences. NHTSA’s underlying impetus to require side impact head protection is purely driven by the hundreds of lives that could be saved each year on U.S. roadways.

c. Aspects of the MDB Test Procedure

A number of commenters responded to the NPRM’s proposed changes to the dynamic MDB side impact test in FMVSS No. 214. The NPRM did not propose changes to the MDB itself.

1. The Moving Deformable Barrier

IIHS, Advocates, CU and Public Citizen believed that the agency should change the design of the moving deformable barrier (MDB) used in the dynamic test to better reflect side impact risks in the current vehicle fleet. Advocates, CU and Public Citizen believed that an upgraded MDB should be used to test all vehicles up to 4,536 kg (10,000 lb). Advocates further stated:

⁷¹ The February 14, 2005 final rule amended the certification requirements of 49 CFR part 567 to allow the use of pass-through certification so that it can be used not only for multistage vehicles based on chassis-cabs, but also for those based on other types of incomplete vehicles. Id.

⁷² See Docket No. NHTSA–2004–17694–43.

"If NHTSA does not extend the proposed oblique pole test to rear seating areas in passenger vehicles, only a MDB-based test that actually results in head injury is worthwhile in connection with adding a head injury measure and criterion to the current Standard No. 214 dynamic test." IIHS stated: "If the agency does not take this opportunity to improve the barrier and if it decides to accept less biofidelic dummy options, it is difficult to see what benefits will accrue from the additional MDB tests that have been proposed."

Agency response: NHTSA considers a redesign of the MDB as a longer term project beyond the scope of the present rulemaking. As noted in the NPRM (69 FR at 27992), initiatives to improve vehicle compatibility between passenger cars and LTVs in side crashes are likely to change the characteristics of striking vehicles in the future. Further, the marketplace is currently fluctuating. When future changes to the fleet have been identified, we can then determine how the agency's existing MDB should be modified to represent striking vehicles.

In response to Advocates, we do not agree that the absence of a pole test requirement for rear seat occupants necessitates the inclusion of a new MDB test that results in head injury. The SID-IIs in the rear seat of several of the vehicles in our test program measured high pelvic loading in FMVSS No. 214 MDB tests. Use of the dummy in the MDB tests and the information it provides about rear seat performance will result in improvements to rear seat occupant protection. Contrary to IIHS, we believe that the use of the ES-2re and SID-IIs dummies will add value to the current upgrade until such a time when a more thorough evaluation of the vehicle fleet and its characteristics can be modeled.

2. A Reasonable Balancing of the Test Burden

A. Arm Position

The NPRM proposed that the driver dummy arm position must be 40 degrees relative to torso, and that the arm for all dummies other than the driver dummy would have the arm in line with the torso. The Alliance commented that, to reduce test burdens and test variability, the arm position for the dummies should be set in the detent representing a 40 degree angle between the torso and the arm for all seating positions specified in the MDB test.

To reduce test burdens and variability, the agency agrees with the Alliance's recommendation to set the arm position for the dummy in the

driver and front passenger seating positions in the detent representing a 40 degree angle between the torso and the arm. Under this change, the front seat dummies' arms will be angled in the same manner on both the right and left sides of the vehicle (i.e., the front seat dummy's arm nearest the door will be raised). This helps to reduce the test burden of the MDB test without decreasing crash protection, since it should be easier for manufacturers to design and better assure that a vehicle will meet the MDB requirements when impacted on either the right or left sides of the vehicle using data from an MDB test of only one side of the vehicle. Based upon pendulum impact tests to the dummy's thorax in which the arm was positioned down and another with a dummy without an arm, the maximum rib deflection occurred when the thorax was fully exposed. We believe that raising the arm of the dummy in the passenger seat test exposes the dummy's thorax in the same way achieved by a dummy without an arm, and that this change to the procedure will thus not degrade the robustness of the test.

B. Reducing the Number of Tests

To reduce unnecessary test burdens, today's final rule specifies that the MDB test will be conducted with an ES-2re in the front seat and a SID-IIs in the rear seat. We will not test using a SID-IIs dummy in the front seat, for the reasons provided earlier in this preamble in the section titled, "Need for the 5th percentile dummy in the MDB test." In contrast, the ES-2re in the front seat will enhance safety at that seating position because of the dummy's enhanced abilities to measure HIC, thoracic and abdominal rib deflections, and pelvic loads. (The current FMVSS No. 214 side impact dummy (SID) does not measure HIC, rib deflections or have any type mechanism that assesses the risk of abdominal injury.)

However, we will not use an ES-2re in the rear seat. In our side impact test program, the ES-2re's responses in the rear seat passed the injury assessment reference values and were generally low. Further, while the ES-2re dummy has rib and abdominal measurement capabilities, the dummy was not able to detect the elevated injury measures found by the SID-IIs dummy in the rear seat MDB tests. Out of the nine tests conducted with the ES-2re rear passenger dummy, only one vehicle had an elevated abdominal force measurement in these tests, as reported in the NPRM (69 FR at 28010). The test was of the 2002 Chevrolet Impala, which has since been redesigned. The 2002 Impala test also resulted in high

pelvic force and lower spine measurements when tested with the SID-IIs due to an intruding armrest. Because this final rule incorporates the SID-IIs dummy in the MDB rear seat test, countermeasures that will be installed to reduce the pelvic force and lower spine acceleration values of the SID-IIs in the rear seat should also address the performance of the rear seat in protecting mid-size adults. Use of the ES-2re in the rear seat of the MDB test would not result in an enhancement of occupant protection.

We do not believe that testing with only the SID-IIs dummy in the rear will degrade rear seat occupant protection to mid-size adult occupants. Our side NCAP program presently uses a mid-sized adult male dummy (the SID-H3) in the rear seating position in the MDB NCAP test, which complements the FMVSS No. 214 MDB test. We will make sure that any future revisions to the NCAP program will continue to complement the standard as upgraded today.

3. Other

NMEDA suggested that: "Mobility vehicles having raised/altere roofs, lowered floors and vehicles equipped with extended travel seating systems be required to meet only the MDB test with the new mid-size male, and therefore be exempt from the MDB requirements for the small female test dummy, until such time as the NHTSA can determine if, in fact, the small female is the most accurate representation of the stature of mobility vehicle occupants."

Agency response: We do not support this suggestion. We are not persuaded by NMEDA's theory that mobility vehicle occupants could be statistically larger than the rest of the population of motor vehicle occupants such that testing with the 5th percentile adult female dummy would not be beneficial. The SID-IIs 5th percentile adult female dummy represents a population that generally has lower impact tolerance levels than the 50th percentile adult male represented by the ES-2re. As explained in the next section of this preamble, our injury criteria for the SID-IIs was developed taking into account the occupant's age, bone mass and size. The injury tolerance levels for the SID-IIs were normalized to that for a 56-year-old, rather than that for a 45-year-old as done for the ES-2re. We have no basis for assuming that the SID-IIs will not be an appropriate test device for testing the rear seat of vehicles manufactured for mobility impaired occupants, and in fact have good reason to think that it will be.

As previously discussed, the agency has reduced the MDB requirements to only include the ES-2re dummy in the front seating position and the SID-IIs dummy in the rear. This reduces the test burden for vehicle manufacturers and should address NMEDA's concerns about the driver seating position.

d. Injury Criteria

In determining the suitability of a dummy for side impact testing, the agency considers the dummy's injury assessment capabilities relative to human body regions at risk in the real world crash environment. Crash data indicate that head, chest, abdomen and pelvic injuries are prevalent in side impacts. Accordingly, injury criteria were proposed for the ES-2re's head, thorax, abdomen, and pelvis.

The types of injury criteria proposed by NHTSA for the ES-2re were generally consistent with those developed by ECE/WP.29, by the European Union in its directive EU 96/27/EC, and by EuroNCAP for rating vehicles. Four of NHTSA's proposed injury criteria were specified in EU 96/27/EC for use with the EuroSID-1 dummy.⁷³ For the SID-IIs, injury criteria were proposed for the head, lower spine, and pelvis. The NPRM did not propose thoracic or abdominal deflection limits using the SID-IIsFRG.⁷⁴

A technical report titled, "Injury Criteria for Side Impact Dummies," May, 2004 (NHTSA docket number 17694) was made available to the public at http://dmses.dot.gov/docimages/pdf89/285284_web.pdf. The report was peer reviewed in accordance with the Office of Management and Budget's (OMB) June 15, 2005 information quality guidelines. Three peer reviewers from academia and industry, considered experts in the field of impact biomechanics and side impact, reviewed the document. The reviewers' comments and the agency's response thereto are available to the public through the DOT peer review website <http://www.dot.gov/peer.htm>.

1. Head Injury Criterion

NHTSA proposed to require a head injury criterion (HIC) limit of 1000

⁷³ NHTSA decided not to use the chest viscous injury criteria, $V^*C \leq 1.0$, because we did not find the V^*C criterion to be repeatable and reproducible in our research.

⁷⁴ The agency did not propose a limit on deflections because, in pendulum tests, the FRG design reduced the SID-IIs's dummy's deflection measurement capability when the ribs were struck in angled pendulum impacts. NHTSA wanted to obtain more information about the FRG's effect on rib deflections before proposing deflection criteria in FMVSS No. 214.

(measured in a 36 millisecond time interval). HIC₃₆ 1000 relates to a 50 percent risk of head injury. The HIC₃₆ 1000 criterion is used throughout the FMVSSs and provides a measure with which the agency and the industry have substantial experience. The HIC₃₆ 1000 criterion is used in the optional pole test of FMVSS No. 201.

Comments on HIC proposal: The Alliance, Nissan, Ferrari, Maserati, and DaimlerChrysler supported the proposed HIC₃₆ criterion of 1000. Advocates and Public Citizen supported a HIC₃₆ criterion of 800, believing that the criterion would reduce the risk of AIS 3+ injury to approximately 35 percent, and that the limit is achievable by current vehicles. Dr. Albert King, a private individual, submitted a paper he co-authored that hypothesized that brain injury is governed by brain response and not the input acceleration. He suggested that the brain response to input translation and rotational head acceleration can be obtained through finite element models and injury potential estimated using strain and strain rates in the brain tissue.

Agency response: This final rule adopts the HIC₃₆ criterion of 1000. The HIC₃₆ limit of 1000 was selected to accord with the FMVSS No. 201 head protection standard. Vehicle manufacturers have experience with the 1000 HIC limit.

Significant research is needed before the potential for estimating brain injury risk using finite element brain models can be assessed. NHTSA did not propose to use a finite element brain model for head injury assessment and this final rule does not adopt such a method.

2. Thorax (Chest) Criteria

A. ES-2re

NHTSA proposed two criteria to measure thoracic injury when using the ES-2re: Chest deflection and resultant lower spine acceleration. Chest deflection has been shown to be the best predictor of thoracic injuries for side impact. The agency believed it to be a better injury risk measure than TTI(d) for the ES-2re dummy.⁷⁵ We added spinal acceleration criteria because we

⁷⁵ TTI(d), a chest acceleration-based criteria, when combined with anthropometric data, was developed by NHTSA (Eppinger, R. H., Marcus, J. H., Morgan, R. M., (1984), "Development of Dummy and Injury Index for NHTSA's Thoracic Side Impact Protection Research Program," SAE Paper No. 840885, Government/Industry Meeting and Exposition, Washington, D.C.; Morgan, R. M., Marcus, J. H., Eppinger, R. H., (1986), "Side Impact—The Biofidelity of NHTSA's Proposed ATD and Efficacy of TTI," SAE Paper No. 861877, 30th Stapp Car Crash Conference) and is included in the FMVSS No. 214 side impact protection standard.

believed that spinal accelerations might detect severe loading conditions that are undetected by the unidirectional deflection measurements. Lower spine acceleration may not have a causal relationship with thoracic injury but is a good indicator of the overall loading to the thorax. The agency believed that in concert, the two thoracic criteria would enhance injury assessment in a vehicle side crash test, and result in reduced chest injuries as compared to the use of TTI(d) in current FMVSS No. 214.

NHTSA selected the two criteria based upon a series of 42 side impact sled tests using fully instrumented post mortem human subjects (PMHS) and 16 sled tests using the ES-2re, conducted at the Medical College of Wisconsin (MCW). NHTSA conducted the analysis using logistic regression with injury outcome in the PMHS sled tests as the response, and ES-2re dummy measured physical parameters (maximum rib deflections, TTI, maximum spinal accelerations) in similar sled tests as the covariates. The subjects' anthropometric data such as age, gender, and mass were also included as covariates since the agency believed that they might influence injury outcome.⁷⁶ This method of analysis provided injury criteria that could directly be applied to the ES-2re dummy.

i. Chest Deflection

Chest deflection was proposed to be not greater than 42 mm for any rib (reflecting an approximate 50 percent risk of an AIS 3+ injury). The NPRM sought comment on an alternative criterion within the range of 35 to 44 mm (1.38 to 1.73 in). The 44 mm (1.73 in) value corresponded to a 50 percent risk of serious injury for a 45-year-old occupant.⁷⁷ The agency determined upon reanalyzing a data set that was used when NHTSA undertook the 1990 rulemaking adopting the MDB test into FMVSS No. 214 that the current TTI(d) of 85 g's corresponds approximately to a 50 percent risk of AIS 3+ injury. Thus, NHTSA tentatively concluded that a rib deflection limit of 44 mm (1.73 in) for the ES-2re could be acceptable on the basis that it was approximately equivalent to the risk of injury

⁷⁶ Kuppa, S., Eppinger, R., McKoy, F., Nguyen, T., Pinter, F., Yoganandan, Y., "Development of Side Impact Thoracic Injury Criteria and their Application to the Modified ES-2 Dummy with Rib Extensions (ES-2re)," Stapp Car Crash Journal, Vol. 47, October, 2003.

⁷⁷ Logistic regression analysis using cadaver injury and anthropometry information along with the ES-2 measurements indicate that the age of the subject at the time of death had a significant influence on the injury outcome ($p < 0.05$). *Id.*

addressed by the current TTI(d) requirement in FMVSS No. 214.⁷⁸

Comments on the ES-2re chest deflection: In an August 16, 2005 comment, the Alliance noted that the injury risk curve from which NHTSA derived its proposed chest deflection limit of 44 mm was based on the MCW studies that analyzed the responses of PMHS and the ES-2re. The Alliance believed that an injury risk curve developed for the ES-2 dummy should be used instead, particularly if the agency agrees with the Alliance's suggestion to use the ES-2 dummy. Moreover, the commenter stated, NHTSA proposed a chest deflection requirement of 42 mm to harmonize with the EU regulation for the EuroSID-1. The Alliance stated that the ES-2 dummy rib deflections have been observed to be approximately 25 to 100 percent larger than those for the EuroSID-1 under the same test conditions. The commenter stated:

Given the difference in deflections noted between the EuroSID-1 and ES-2 dummies, the Alliance believes that the injury limit for thoracic deflection in the ES-2 should be at least 25% greater than the limit derived from the risk curve if the EuroSID-1 is used. Therefore, the value of 42 mm in the European regulation derived with EuroSID-1 would be multiplied by 1.25, which leads to a value of 53 mm for the deflection limit proposed by the Alliance.

Advocates and Public Citizen believed that even the 35 mm deflection limit at the low end of the proposed range was too high to protect the elderly population. Advocates believed that the proposal "will disproportionately take the lives of, and inflict much more serious injuries on, occupants 65 years of age and older" and stated that it did not support any value within the range proposed.

Agency response: This final rule adopts a chest deflection threshold of 44 mm, which corresponds to a 50 percent risk of AIS 3+ injury for a 45-year-old. We do not agree with the Alliance's suggestion that, because the ES-2 dummy records higher rib deflections than the EuroSID-1, the chest deflection limit for this final rule should be 53 mm.

Many researchers have shown that the ES-2 dummy records higher rib deflections than the EuroSID-1. Samaha *et al.* reported higher rib deflections with the ES-2 dummy than with the EuroSID-1 dummy in identical side impact vehicle crash tests conducted in

accordance with the EU 96/EC/27 side impact procedure.⁷⁹ When developing the NPRM, we determined that the thorax of the ES-2 was so different from that of the predecessor EuroSID-1 dummy that previously-generated EuroSID-1 data should not be used in analyzing the ES-2 and its associated thoracic injury criteria. Consequently, NHTSA stated in the NPRM that, in developing the injury criteria for the ES-2re, we would use risk curves and other information resulting from our research conducted with the ES-2re. (69 FR at 28002)

That research included paired sled tests at the Medical College of Wisconsin with PMHS and the ES-2re dummy in various impact wall configurations. "Injury Criteria for Side Impact Dummies," *supra*. The analysis of the test data indicated a 50 percent risk of thoracic injury at 44 mm of maximum thoracic rib deflection. We viewed favorably that a rib deflection limit of approximately 44 mm for the ES-2re would be harmonized with the 42 mm limit in the EU regulation, in that the IARV of 42 mm in the EU regulation corresponded to a 50 percent risk of nine rib fractures, which was associated with serious injury (internal organ injuries and flail chest). (69 FR at 28002, footnote 33.) That is, the chest deflection limits of the two regulations generally correspond to equivalent limits on the risk of serious chest injury, which could promote the development of similar countermeasures.

With regard to the comment from Advocates and Public Citizen, the agency acknowledges that the elderly and small size occupants generally have lower impact tolerance levels than younger, larger occupants. For this reason, the injury tolerance levels for the 5th percentile female were normalized to that for a 56-year-old, rather than that for a 45-year-old as done for the 50th percentile male dummy. These injury tolerance levels are reasonable, balancing to the extent possible the dual goals of practicability and optimum safety performance. The agency thus believes that a final rule that uses both the 5th percentile adult female dummy and the 50th percentile male dummy affords practicable protection to the elderly as well as to a more generalized population.

ii. ES-2re Lower Spine Acceleration

Resultant lower spine acceleration was proposed to be not greater than 82 g (reflecting a 50 percent risk of an AIS 3+ injury). The upper and lower spine of the ES-2re is instrumented with tri-axial accelerometers (x, y, and z direction corresponding to anterior-posterior, lateral medial, and inferior-superior). In both oblique pole and MDB side vehicle crashes, loading can be in various directions due to the complexities of the intruding surfaces. Therefore, NHTSA believed that to account for overall loading, resultant accelerations should be measured.

Comments on ES-2re lower spine acceleration: The Alliance did not agree with the use of the lower spine acceleration as a supplementary criterion for thoracic injury criterion. The Alliance believed that the criterion is a poor predictor of injury outcome. The Alliance stated that "thoracic deflection is a direct measure of injury potential by itself and that the addition of acceleration will only unnecessarily restrict designs using an unproven and poorly correlated parameter." Further, the Alliance suggested that the lower spine acceleration criterion might be unnecessary for the ES-2re, in that the dummy's rib deflection readings alone should detect injurious loading of the thorax.

Agency response: We have determined that it is unnecessary to limit lower spine acceleration in the pole and MDB tests of the ES-2re dummy. Accordingly, this final rule does not adopt the lower spine acceleration limit in this rulemaking for the ES-2re. In the oblique pole tests conducted in our 214 fleet testing program, the ES-2re's lower spine acceleration readings were relatively consistent with the dummy's rib deflection readings. Eleven tests showed elevated rib deflections. Of these eleven, five also had elevated lower spine acceleration. The lower spine acceleration of the ES-2re was elevated (75 g) in one vehicle (the Ford Expedition) when the dummy's rib deflection was low (26 mm), but the lower spine response could have been elevated due to high abdominal loads (the ES-2 recorded a 6,973 N abdominal force in that test). Because the lower spine acceleration measurements fairly tracked the ES-2re's rib deflections, we conclude that, in the oblique pole and MDB tests, the lower spine acceleration criterion is unnecessary for the ES-2re.⁸⁰ The dummy's rib deflection

⁷⁸ NHTSA reanalyzed the Eppinger data set that was used in the 1990 MDB rulemaking. Kuppa *et al.*, "Development of Side Impact Thoracic Injury Criteria and their Application to the Modified ES-2 Dummy with Rib Extensions (ES-2re)," *id.*

⁷⁹ Samaha, R., Maltese, M., Bolte, J., (2001), "Evaluation of the ES-2 Dummy in Representative Side Impacts," Seventeenth International Technical Conference on the Enhanced Safety of Vehicles, Paper No. 486, National Highway Traffic Safety Administration, Washington, DC.

⁸⁰ In its comment, Honda noted that the NPRM May 17, 2004 specified that acceleration data from

measurements alone will detect injurious loading of the thorax.

Although we are not adopting the lower spine acceleration limit as suggested by the Alliance, we do not agree with the Alliance's suggestion that the addition of acceleration will unnecessarily restrict designs. The Alliance submitted no data or any other information explaining or substantiating this comment. Further, we have not seen inconsistencies between the rib deflection and lower spine acceleration criteria that support that contention.

B. SID-IIs Lower Spine Acceleration

For the SID-IIs dummy, the agency proposed a limit of 82 g on the resultant lower spine acceleration, which is a measure of loading severity to the thorax. In vehicle crashes, loading can be in various directions. Therefore, NHTSA believed that to account for overall loading, resultant accelerations should be considered rather than lateral acceleration alone. The agency recognized that dummy-measured accelerations for the level of loading severities experienced in vehicle crashes might not have a causal relationship to injury outcome. However, the agency believed that they are good indicators of thoracic injury in cadaver testing and of overall loading to the dummy thorax.

NHTSA selected the 82 g resultant lower spine acceleration based upon a Receiver Operator Characteristic curve (ROC) developed using the data from the series of MCW PMHS sled tests and the sled tests conducted with the SID-IIs dummy under impact conditions identical to those of the MCW tests. NHTSA estimated the thoracic criteria that were associated with a 50th percent risk of AIS 3+ injury in the PMHS. As noted above, accelerations measured in a pole and MDB crash test soundly

the accelerometers on the ES-2re lower spine would be filtered at channel frequency class of 1000 Hz (proposed S11.5(b)(3), 69 FR at 28027). Honda believed that SAE filter channel class 180 should be used instead, and pointed out that NHTSA used SAE filter channel class 180 in developing the injury criteria for the side impact dummies. The commenter is correct that S11.5(b)(3) of the NPRM should have specified SAE filter class 180. NHTSA's intent to adopt SAE filter class 180 is shown by the document referenced by Honda, and by the December 14, 2006 final rule adopting the ES-2re dummy into 49 CFR part 572, which specifies SAE filter class 180 in 572.189(4). However, because we are not adopting the lower spine acceleration injury assessment limit, the specification for the lower spine filter class is not necessary and we have removed the filter class specification from FMVSS No. 214. In addition, this final rule specifies that the dummy's rib deflection data are filtered at channel frequency class 600 Hz, not 180 Hz, in accordance with SAE Recommended Practice J211, "Instrumentation For Impact Test, Part 1, Electronic Instrumentation."

indicate overall loading to the dummy thorax, which, in turn, can be used to indicate when the thorax has been exposed to overload conditions in a crash. However, to minimize instances where accelerations above the threshold value results in no serious injury, the agency set the maximum lower spine acceleration at 82 g. (See "Injury Criteria for Side Impact Dummies," *id.*) The agency also believed that the age of the subject involved in a side impact affects injury outcome. Subject age in the MCW sled test data was found to have significant influence on injury outcome and so was included in the injury models. (NHTSA normalized the risk curve to the average occupant age of 56 years.)

Comments on SID-IIs lower spine acceleration: The Alliance disagreed with the proposal to use a deflection-based criterion for the ES-2re and an acceleration-based criterion for the small female dummy.⁸¹ The Alliance believed that limiting accelerations would not assure that thoracic injury will not occur, and that chest deflection is the best predictor of injury. The Alliance stated: "It is possible to have balanced restraint loads, as indicated by low thoracic spine accelerations, but to have large, injurious rib deflections. Limits must be placed on thoracic and abdominal rib deflections to assure that the risks of thoracic and abdominal injuries are at acceptable levels for the simulated accident condition."

IIHS likewise strongly supported the use of deflection measures.

Advocates took "no specific position" on the proposed limit of 82 g but believed that the value might be excessive with regard to older vehicle occupants. The commenter agreed with the NPRM that resultant accelerations should be considered rather than lateral acceleration alone.

Agency response: NHTSA agrees with the Alliance and IIHS that the SID-IIs thoracic and abdominal rib deflections are a critical part of the dummy. However, adopting limits on the rib deflections of the SID-IIs would be outside the scope of this rulemaking and thus is not a part of this final rule. Nonetheless, as stated earlier in this preamble, we may undertake future rulemaking to propose to limit the thoracic and abdominal rib deflections measured by the SID-IIs in the FMVSS No. 214 MDB and pole tests.

Since we are not adopting in this final rule thoracic and abdominal deflections for the SID-IIs, a criterion for lower spine acceleration is especially

⁸¹ The Alliance stated that it supported use of the SID-IIs dummy for research purposes.

important. The criterion can detect injurious loading conditions to the abdomen and lower thorax. Test data from the agency's 214 fleet testing program indicate that 6 of the 10 vehicle tests with the SID-IIs resulted in rib deflection measurements exceeding a limit of 38 mm for the thoracic rib (which corresponds to a 50 percent risk of AIS 3+ injury), and/or a limit of 45 mm for the abdominal rib (the 45 mm limit is used by IIHS in its consumer information program). In all of these, the lower spine acceleration values were also elevated (exceeding 82 g or within 80 percent of 82 g (*i.e.*, 66 g)). The 6 tests were of the: 2005 Toyota Corolla, 2005 Saturn Ion, 2005 Ford Five Hundred, 2004/05 Toyota Sienna, 2005 Chevy Colorado 4x2 extended cab, and the 2005 Ford Expedition. Likewise, the lower spine acceleration criterion identified elevated loading conditions in the test of the 2005 Honda CRV. In that test, the SID-IIs abdominal rib deflection was 36 mm (within 80 percent of 45 mm), and the lower spine was 68 g (within 80 percent of 82 g).

Thus, the data show that the lower spine acceleration readings were generally consistent with the SID-IIs's rib deflections. The criterion was generally able to identify tests in which a vehicle was unable to keep rib deflections from exceeding threshold levels. The lower spine acceleration criterion meets the need for a good indicator of thoracic injury and of overall loading to the dummy thorax. The lower spine acceleration is particularly needed in the absence of a rib deflection criterion for the SID-IIs, or any other mechanism that will ensure that vehicles are best designed with abdominal and thoracic protection for the small occupant in mind. In the future, if NHTSA were to adopt limits on the thoracic and abdominal rib deflections measured by the SID-IIs in the FMVSS No. 214 crash tests, the agency would consider as part of that rulemaking the need for limiting both lower spine acceleration and rib deflections.

Resultant accelerations will be measured rather than lateral acceleration alone, for the reasons provided in the NPRM. In response to Advocates, the injury tolerance level for the 5th percentile female were normalized to that for a 56 year old, rather than that for a 45 year old as done for the 50th percentile male dummy. The 82 g injury tolerance level is reasonable, balancing to the extent possible the dual goals of practicability and optimum safety performance.

3. ES-2re Abdominal Criterion

The ES-2re dummy offers abdominal injury assessment capability, a feature that is not present in the SID dummy. The agency proposed an abdominal injury criterion of 2,500 Newtons (N) (562 pounds). The agency sought comment on an alternative abdominal injury criterion within the range of 2,400–2,800 N (540–629 pounds). This range corresponds to an approximate 30–50 percent risk of AIS 3+ injury.

The proposed abdominal injury criterion was developed using cadaver drop test data from Walfisch, *et al.* (1980).⁸² Analysis of this data indicated that applied force was the best predictor of abdominal injury, and an applied force of 2,500 N (562 pounds) corresponds to a 33 percent risk of AIS 3+ injury. The MCW sled test data indicated that the applied abdominal force on the cadavers was approximately equal to the total abdominal force in the ES-2re dummy under similar test conditions.

Comments on abdomen proposal: Ferrari supported the proposed abdominal force limit of 2,500 N because it was consistent with harmonization. The Alliance stated that the 2,500 N limit appears to be reasonable. The Alliance also stated that there were inconsistencies in the calculations of total abdominal force in the NPRM. In some cases the abdominal loading was calculated through instantaneous summation of the individual load cells, while in other cases the summation of individual peak values was utilized. The Alliance stated that it believed that an instantaneous summation of the abdominal load cells is the correct method to determine the total abdominal force in the ES-2 dummy.

Agency response: This final rule adopts an abdominal force limit of 2,500 N for the reasons provided in the proposal. In response to the Alliance, the abdominal force has and will be calculated as the instantaneous summation of the abdominal load cell measurements.

4. Pelvic Criterion

A. ES-2re

NHTSA proposed an ES-2re pelvic force limit of not greater than 6,000 N (1,349 pounds) (25 percent risk of AIS 3+ injury). The ES-2re has two pelvic measurement capabilities. First, the ES-2re has instrumentation to measure pelvic acceleration, as does the SID

dummy. However, unlike the SID, the ES-2re is also capable of measuring the force (load) at the pubic symphysis, which is the region of the pelvis where the majority of injuries occur. A field analysis of 219 occupants in side impact crashes by Guillemot, *et al.* (1998) showed that the most common injury to the pelvis was fracture of the pubic rami (pelvic ring disruption).⁸³ Pubic rami fractures are the first to occur because it is the weak link in the pelvis.

The NPRM proposed to limit only pubic symphysis force. The agency did not propose an acceleration-based criterion because the agency believed that an injury threshold limit on pelvic acceleration is dependent on the impact location and the type of loading (distributed versus concentrated). Therefore, the agency did not believe that pelvic acceleration is as good a predictor of pelvic fracture as force. The scientific literature has documented that force alone is a good predictor of pelvic injury.⁸⁴ Further, the pubic symphysis load injury criterion has been applied in the European side impact regulation EU 96/27/EC as well as the EuroNCAP Program, so there is experience with this measure and some demonstration of its usefulness. The criterion in those programs is 6,000 N (1,349 lb).

Comments on ES-2re pelvis proposal: The Alliance did not agree with the NPRM that the ES-2re dummy has provisions for instrumentation that can assess the potential for acetabulum and public symphysis injuries by way of load cell measurements. In its August 2005 comment, the Alliance stated that although vehicles can meet a 6,000 N criterion, it is concerned that no experiments have been published documenting what the pubic symphysis load was at time of fracture, or as a function of external load for a human subject. The Alliance also stated that there are no data on the relationship of pubic symphysis load with impact velocity. The commenter recommended further study of the issue before a criterion is adopted.

Ferrari agreed with the pelvic force limit of 6,000 N, while Advocates believed that the proposed pelvic force

limit of 6,000 N is too high to protect the elderly.

Agency response: NHTSA used the Bouquet pendulum test data to relate the applied pelvic force to cadavers to the pubic symphysis force of the EuroSID-1 dummy for identical test conditions. The impact surface in these tests loaded the iliac crest as well as the trochanter.⁸⁵ The impactor mass varied between 12 kg to 16 kg and the impactor speed from 6 m/s to 13.7 m/s. Since the EuroSID-1 pelvis is similar to that of the ES-2re, the similar relationship would apply to the ES-2re. For AIS 2+ injured subjects, the dummy pelvic force corresponds to 0.455 times applied pelvic force to the cadaver.

The reanalysis of the Bouquet data after normalizing for the weight of the subject as well as the confirmation of the injury risk curves using the Zhu and Cavanaugh test data suggests that NHTSA's injury risk curves and applied injury threshold for AIS 3+ pelvic fractures are reasonable. While the relationship between the ES-2 public loads and the cadaver applied force are dependent on the loading condition, similar scaling relationships have been used successfully for years for the EuroSID-I in the EU regulation.

B. SID-IIs

For the SID-IIs dummy, the pelvic injury criterion was developed from an analysis of the same cadaver impact data that was used for the development of the ES-2re pelvic injury criterion. The measured loads in these impact tests were distributed over a broad area of the pelvis that included the iliac crest and the greater trochanter. The measured applied pelvic force to the cadaveric subjects was mass-scaled to represent the applied forces on a 5th percentile female. Under similar impact conditions, the scaled applied pelvic force on the cadaveric subjects was assumed to be equal to the sum of the iliac and acetabular forces measured on the SID-IIs dummy.⁸⁶ Therefore, the pelvic injury risk curves developed for the SID-IIs dummy were based on the maximum of the sum of the measured acetabular and iliac force. The proposed 5,100 N force level for the SID-IIs corresponded approximately to a 25 percent risk of AIS 2+ pelvic fracture.⁸⁷

⁸⁵ The bony protrusion at the top of the femoral shaft opposite the ball of the hip joint.

⁸⁶ IIHS used the same assumption when developing performance standards for its consumer ratings program. See Arbalaez, R. A., *et al.*, "Comparison of the EuroSID-2 and SID-IIs in Vehicle Side Impact Tests with the IIHS Barrier," 46th Stapp Car Crash Journal (2002).

⁸⁷ In the IIHS side impact consumer ratings program, 5,100 N is the injury parameter cutoff

⁸² Walfisch, G., Fayon, C., Terriere, J., *et al.*, "Designing of a Dummy's Abdomen for Detecting Injuries in Side Impact Collisions, 5th International IRCOBI Conference, 1980.

⁸³ Guillemot H., Besnault B., Robin, S., *et al.*, "Pelvic Injuries In Side Impact Collisions: A Field Accident Analysis And Dynamic Tests On Isolated Pelvic Bones," Proceedings of the 16th ESV Conference, Windsor (1998).

⁸⁴ Bouquet, *et al.* (1998) performed cadaver pendulum impact tests and showed that the pubic symphysis load cell in the EuroSID-1 dummy was a good predictor of pelvic fracture. See Bouquet, R., Ramet, M., Bermond, F., Caire, Y., Talantikite, Y., Robin, S., Voiglio, E., "Pelvis Human Response to Lateral Impact," Proceedings of the 16th Enhanced Safety of Vehicles (ESV) Conference (1998).

Comments on SID-IIs pelvis proposal: The Alliance commented that NHTSA's assumption that the normalized applied pelvic force in the cadaver tests was equal to the sum of the forces in iliac wing and acetabulum was not based on test data. In a September 2, 2005 comment, the Alliance submitted component test data showing the distribution of forces between the iliac and acetabulum measured by PMHS and the SID-IIs. The commenter disagreed with the normalization of pelvic responses by the mass of the subject because, the commenter stated, the Alliance's data suggest only a weak relationship between pelvic mass and geometry with the overall subject mass. The commenter believed that the sum of the internal forces (acetabulum plus sacro-iliac) is approximately 75 percent of the applied external force on the SID-IIs dummy. Based on this information, the Alliance stated that "Even though the injury risk curves and associated relationship between PMHS and dummy data would have to [be] recalculated based on non-normalized data, an initial IARV for 25% risk of AIS 3+ pelvic injury could be set at 8.55kN (0.75*11.4kN) for maximum combined acetabulum and iliac loads."

The Alliance also stated that there were inconsistencies in the calculations of combined pelvic force in the NPRM. In some cases the combined pelvis loading was calculated through instantaneous summation of the iliac and acetabulum load cells, while in other cases the summation of individual

peak values was utilized. The Alliance stated that it believed that an instantaneous summation of the iliac and acetabulum load cells is the correct method to determine the combined pelvic force for the SID-IIs.

Advocates said that older occupants suffering pelvic fracture are at a much higher risk of death. Advocates believed that vehicles equipped with side thorax bags could be able to meet a lower value. The commenter agreed with NHTSA that resultant accelerations should be considered rather than lateral acceleration alone.

Agency response: The Bouquet pelvic impact test data indicated that for the same test conditions, the applied force on a lighter subject that results in injury was lower than that on a heavier subject. The agency continues to believe that such data should be normalized to a representative anthropometric subject. The normalizing procedure adopted was that of mass scaling, which has been applied by other researchers as well.⁸⁸

To obtain the injury risk curve for a small female, the agency normalized the pelvic force data from the Bouquet pelvic impact tests to that of a small female weighing 48 kg (105 lb), as indicated in the technical document, "Injury Criteria for Side Impact Dummies," *supra*. In addition, the risk curve was adjusted to that for a 56 year old. At the time of developing the risk curve, there was no data available to relate the applied cadaver pelvic force in the Bouquet tests to equivalent acetabulum and iliac force measured in

the SID-IIs. Therefore, it was assumed that the applied cadaver pelvic force is equal to the sum of acetabular and iliac force in the SID-IIs.

NHTSA analyzed the SID-IIs data submitted by the Alliance on September 2, 2005 in conjunction with the relevant cadaver tests from Bouquet. We believe that the submitted data suggested that the sum of acetabular and iliac force of the SID-IIs is approximately 1.21 times that of the applied cadaver force under similar impact conditions of the Bouquet test setup. Accordingly, rather than the proposed pelvic force limit of 5,100 N, we have adopted a pelvic force IARV limit of 5,525 N, which corresponds to a 25% risk of AIS 2+ injury using also a factor for reduced bone strength in older women (0.88). We note that IIHS considered a 5,525 N pelvic force to be in the middle of the acceptable range for the IIHS consumer ratings program.

The combined pelvic force is calculated as an instantaneous summation of the measurements from the iliac and acetabulum load cells.

In response to Advocates, the 5,525 N sum of acetabular and iliac force corresponds to the pelvic injury tolerance for a 56 year old 5th percentile female. This tolerance level thus accounts for the age of the occupant, and provides practicable protection to the elderly occupant.

For convenience of the reader, the injury criteria adopted by this final rule are summarized below in Table 11:

TABLE 11.—FINAL RULE INJURY CRITERIA

	HIC ₃₆	Chest deflection (mm)	Lower spine (g)	Abdominal force (N)	Pelvic force (N)
ES-2re	1,000	44	N/A	2,500	6,000
SID-IIs	1,000	N/A	82	N/A	5,525

e. Lead Time

1. Pole Test

The agency proposed a phase-in period for the new vehicle-to-pole test based on crash test data (see, e.g., Appendix C of this preamble), the technologies that could be used to meet the proposed testing requirements, and the relatively low percentage of the fleet that had side air bags that were capable of meeting the proposed requirements. The NPRM proposed to include provisions under which manufacturers

can earn credits towards meeting the applicable phase-in percentages if they meet the new requirements ahead of schedule. The NPRM proposed the following phase-in schedule:

- During the production year beginning four years after publication of a final rule, 20 percent of each manufacturer's light vehicles manufactured during the production year must comply with the requirements of the oblique pole test;
- During the production year beginning five years after publication of a final

rule, 50 percent of each manufacturer's light vehicles manufactured during that production year must comply with the requirements;

- All vehicles manufactured on or after September 1 six years after publication of a final rule must comply with the requirements.

In addition, we proposed a separate alternative to address the special problems faced by limited line manufacturers, alterers, and multistage manufacturers in complying with the

value for the "Good-Acceptable" range for the combined acetabulum and ilium force values. http://www.highwaysafety.org/vehicle_ratings/measures_side.pdf

⁸⁸ Zhu, J., Cavanaugh, J., King, A., "Pelvic Biomechanical Response and Padding Benefits in Side Impact Based on a Cadaveric Test Series," SAE

Paper No. 933128, 37th Stapp Car Crash Conference, 1993.

phase-in. NHTSA accordingly proposed to permit these manufacturers the option of achieving full compliance when the phase-in is completed.

Comments received: The Alliance supported the proposed phase-in schedule for the oblique pole test. Air bag supplier TRW believed that the technology exists to meet the proposed performance requirements within the proposed timeframes and stated that it was prepared to respond to the needs of the manufacturers. Advocates, Consumers Union, and Public Citizen supported a three-year phase-in but recommended that the phase-in period begin two years after publication of a final rule. Advocates stated that if the agency were to adopt an earlier starting year than what had been proposed, it would support a more protracted phase-in of four years for the new pole test and a two-year phase in of an upgraded MDB test. These commenters believed that the earlier phase-in period is supported by agency test results that the commenters believed showed that the majority of vehicles could comply relatively quickly with the new requirements.

RVIA supported the agency's proposal to allow alterers and multistage manufacturers to certify compliance at the end of the phase-in period. However, both RVIA and NTEA stated that chassis manufacturers do often not provide information until the last possible moment before the compliance date. Therefore, these commenters requested that we allow multistage manufacturers and alterers an additional year for compliance certification.

Maserati and Ferrari supported the proposal to allow small volume vehicle manufacturers until the end of the phase-in period before having to certify for compliance.

Agency response: After reviewing the comments to the NPRM, the results of the 214 fleet testing program, and production plans which show installation of side air bags in vehicles ahead of the proposed schedule, we have determined that it would be practicable to provide a 2-year lead time instead of the 4-year lead time proposed in the NPRM leading up to the beginning of the phased-in pole test requirements. Compared to the original schedule, this would accelerate the benefits expected to be provided by side air bag systems and other countermeasures by phasing-in the requirements starting with 20 percent of model year (MY) 2010 vehicles. Comments from air bag suppliers indicate that the schedule is practicable.

As explained in the FRIA, the phase-in schedule and percentages of this final

rule facilitate the installation of side impact air bags and other safety countermeasures in light vehicles as quickly as possible, while the allowance of advanced credits provides manufacturers a way of allocating their resources in an efficient manner to meet the schedule. At the same time, many of the vehicles tested by the agency using the ES-2re and SID-IIs dummies produced dummy readings that exceeded the new pole test performance requirements. This confirms our belief that vehicle manufacturers are at different stages with respect to designing side impact air bags, and also face different constraints and challenges (e.g., differences in the technological advances incorporated in their current air bag systems, in engineering resources, and in the number and type of vehicles in which air bags need to be redesigned). Further, manufacturers' product plans also show that they are at different stages with regard to planning for installation of side impact air bags, particularly thorax bags in light trucks.

Our rationale for the lead time and phase-in is discussed in detail in the FRIA for this final rule, and is summarized below.

- The agency analyzed the product plans submitted by seven vehicle manufacturers, whose combined production accounts for approximately 90 percent of all light vehicle sales, responding to a NHTSA request for planned side air bag installations and projected sales through model year (MY) 2011. The data show that 90 percent of all MY 2010 light vehicles will be equipped with side air bags protecting the head, and 72 percent will be equipped with side air bags protecting the thorax. The percentage of side air bags protecting the head is fairly uniform between the manufacturers; however, there are large differences between manufacturers in the percentage of thorax bags being planned, particularly for light trucks.

- The agency's 214 fleet testing program indicated that the majority of currently available head side air bags would meet the head protection requirement of this final rule's pole test (about 80 percent of tested vehicles equipped with head air bags passed the pole test). However, of the vehicles tested equipped with thorax bags, only 56 percent met the chest requirement in the pole test. One large truck (GVWR greater than 8,500 lb) that was tested also exceeded the injury criteria, indicating that structural changes may be needed.

- From our testing, it appears that the pole test data show that side air bags installed in most passenger cars and

small and medium size light trucks (including SUVs and minivans) may not need extensive modifications. While some of the window curtains and thorax bags we tested were not wide enough to provide the protection desired in the oblique impacts when tested with the SID-IIs 5th percentile female dummy, we believe that a two-year lead time is reasonable to redesign the head and thorax bags. It also appeared that extensive vehicle structural modifications were not necessary for the passenger cars and small and medium size light trucks. On the other hand, we estimate that it will take longer than two years to add a thorax bag to a vehicle model that has not had one previously.

- For large light trucks, the test results indicate that structural changes may be needed. This is why we have provided a longer lead time for vehicles with a GVWR greater than 8,500 lb. Based on our experience, if structural changes are needed, the modification could be done within 3–4 years.

The agency analyzed the above factors in determining the lead time and phase-in requirements of this final rule. The 20 percent level at the two-year mark reflects the manufacturers' production plans for the next two years: for vehicles that already have side air bags but whose bags do not comply with the pole test, two years provides sufficient time for manufacturers to make bags wider and potentially make other changes to pass the test, while it takes longer than two years to add one to a vehicle that has not had one previously. The 50 percent phase-in percentage with a three-year lead time could result in one manufacturer introducing side thorax air bags ahead of its plans, but we believe it would be practicable to introduce thorax bags with 3 years of lead time, particularly with the use of advanced credits. The 75 percent phase-in percentage was adopted to elongate the phase-in schedule one year longer than proposed, to provide vehicle manufacturers the flexibility of a four-year phase-in schedule to incorporate side structure and restraint system modifications into their production cycles. Most vehicle lines would likely experience some level of redesign over the next three to four years. The additional phase-in year provides more opportunity to incorporate side impact protection design changes during the course of each manufacturer's normal production cycle.

In addition, as discussed in section IV.b.10 of this preamble, "Vehicle exclusions," this final rule provides more lead time to meet the pole test requirements to manufacturers of vehicles with a GVWR greater than

3,855 kg (8,500 lb) than proposed in the NPRM. These vehicles need more lead time because they have never been regulated under FMVSS No. 214's dynamic requirements and are not subject to the industry's voluntary commitment to install side air bags. Because these vehicles may need more redesign of the vehicle side structure, interior trim, and/or optimization of dynamically deploying head/side protection systems than light vehicles, this final rule does not subject these vehicles to the pole test requirements until September 1, 2013.

In response to the RVIA and NTEA, NHTSA has issued a final rule pertaining to certification requirements for vehicles built in two or more stages and altered vehicles.⁸⁹ In relevant part, the multi-stage certification final rule amended 49 CFR 571.8, *Effective Date*, to add a new subparagraph (b) providing as follows:

Vehicles built in two or more stages and altered vehicles. Unless Congress directs or

the agency expressly determines that this paragraph does not apply, the date for manufacturer certification of compliance with any standard, or amendment to a standard, that is issued on or after September 1, 2006 is, insofar as its application to intermediate and final-stage manufacturers and alterers is concerned, one year after the last applicable date for manufacturer certification of compliance. Nothing in this provision shall be construed as prohibiting earlier compliance with the standard or amendment or as precluding NHTSA from extending a compliance effective date for intermediate and final-stage manufacturers and alterers by more than one year.

Applying the above provision of the February 14, 2005 final rule to this rulemaking, we have provided final-stage manufacturers and alterers an additional year after completion of the phase-in to certify compliance of their vehicles with the pole test requirements. The manufacturers may voluntarily certify compliance with the standard prior to this date.

For convenience of the reader, the phase-in schedule (with advanced

credits) adopted by this final rule is summarized below and in Table 12:

- 20 percent of a vehicle manufacturer's "light" vehicles (GVWR less than or equal to 3,855 kg (8,500 lb)) manufactured during the period from September 1, 2009 to August 31, 2010 will be required to comply with the standard;⁹⁰
- 50 percent of light vehicles manufactured during the period from September 1, 2010 to August 31, 2011;
- 75 percent of light vehicles manufactured during the period from September 1, 2011 to August 31, 2012;
- All light vehicles manufactured on or after September 1, 2012, including those produced by limited line and small volume manufacturers, without use of credits;
- All vehicles with a GVWR greater than 3,855 kg (8,500 lb) manufactured on or after September 1, 2013 and all vehicles produced by alterers and multistage manufacturers, without use of credits.

TABLE 12.—FINAL RULE PHASE-IN SCHEDULE

Production period	Percent of each manufacturer's vehicles that must comply during the production period ⁹¹
September 1, 2009 to August 31, 2010	20 percent (excluding vehicles GVWR >8,500 lb).
September 1, 2010 to August 31, 2011	50 percent of vehicles (excluding vehicles GVWR >8,500 lb).
September 1, 2011 to August 31, 2012	75 percent of vehicles (excluding vehicles GVWR >8,500 lb).
On or after September 1, 2012	All vehicles (excluding vehicles GVWR >8,500 lb), all vehicles produced by limited line and small volume manufacturers.
On or after September 1, 2013	All vehicles GVWR >8,500 lb, all vehicles manufactured by alterers and multistage manufacturers.

2. MDB test

The agency believed that manufacturers could meet the requirements of the upgraded MDB test without the need for a phase-in period. Therefore, we proposed that the upgraded MDB test would be effective 4 years after publication of a final rule. The agency requested comments on whether it would be appropriate to establish a phase-in for this requirement and whether a lead time shorter than 4 years would be appropriate.

The Alliance, DaimlerChrysler, Nissan, and Ferrari did not support the different effective dates for the pole test and the MDB test. The Alliance believed that "occupant safety benefits are optimized and manufacturers' engineering resources are best utilized if the MDB and pole test requirements are addressed in vehicle designs

simultaneously." The commenter also suggested that there should be an opportunity for limited line manufacturers to apply credits against the full compliance requirement for one year. DaimlerChrysler anticipated that "the requirements represented in the oblique pole test may effect [sic] structural changes which, in turn, will influence performance in the MDB test mode." DaimlerChrysler believed that designing to the MDB and pole tests "represents a development task which will require at least one product cycle (6 to 8 years) to complete."

Nissan stated that its experience with side impact crashes leads it to believe that significant changes would be necessary to comply with the proposed MDB requirements. It also noted that the application of advanced credits would allow Nissan to more efficiently

distribute resources to meet the proposed requirements.

Ferrari believed that "improved chest protection would be needed even by vehicles whose armrest is already designed to reduce the risk of abdominal injuries, and changes would also be needed to vehicles that provide good to optimum chest protection when tested according to SINCAP or EuroNCAP." In Ferrari's opinion, the upgraded MDB test would require equal, if not greater, amount of redesign as the pole test. Therefore, it recommended the same phase-in time as was proposed for the pole test.

In contrast, Advocates, Consumers Union, and Public Citizen supported not having a phase-in for the upgraded MDB test.

Agency response: After consideration of the comments, NHTSA has decided

⁸⁹ See 70 FR 7414 (Feb. 14, 2005).

⁹⁰ Limited line and small volume manufacturers, alterers, and multistage manufacturers, are excluded from the 20/50/75 phase-in requirements. A small volume manufacturer is an original vehicle

manufacturer that produces or assembles fewer than 5,000 vehicles annually for sale in the United States. Limited line and small volume manufacturers, alterers, and multistage manufacturers are provided extra lead time so that

they may maximize resources in planning to comply with the final rule.

⁹¹ Limited line and small volume manufacturers, alterers, and multistage manufacturers, are excluded from the 20/50/75 phase-in requirements.

to adopt a phase-in for the MDB test, and align the phase-in schedule with the oblique pole test requirements, with advance credits. An aligned phase-in will allow manufacturers to optimize engineering resources to design vehicles that meet the MDB and pole test requirements simultaneously, thus reducing costs. Manufacturers, such as Nissan, will also be able to use credits to more efficiently distribute their resources to meet the requirements. It will also allow limited line manufacturers the opportunity to comply with the phase-in schedule with credits, or alternatively to achieve full compliance when the phase-in is completed. Final-stage manufacturers and alterers will be required to comply with the MDB test requirements at the end of the phase in, but may voluntarily certify compliance with the requirements prior to this date.

In response to Advocates, Consumers Union, and Public Citizen, the agency believes that it is appropriate to provide flexibility to manufacturers to upgrade both the pole and MDB requirements on the same schedule. When the agency published the NPRM, we did not anticipate that vehicles would need many structural changes to comply with the MDB test. We originally thought that the countermeasures necessitated by the rulemaking would entail a simple redesign of the door trim armrest area with additional padding and/or re-contouring of the door trim surface. However, upon review of the comments and the results of our own limited testing with the SID-IIs in the MDB tests, we agree with Nissan and Ferrari that required changes might involve a redesign of the vehicle side structure, particularly to address high pelvic loading and elevated rib deflections of the SID-IIs in the rear seats of some vehicles. By aligning the phase-in schedule of the new MDB requirements with the pole test, the agency believes that vehicle manufacturers can better optimize their vehicle designs and the overall occupant protection systems for side impact crashes.

In addition, the Alliance, Honda, and other commenters requested NHTSA to consider adopting the WorldSID into 49 CFR part 572 and using the dummy in the phase-in of this final rule. We are currently evaluating the dummy for possible incorporation into part 572. If incorporation of the dummy appears reasonable, we could undertake rulemaking on the WorldSID to integrate the dummy into the pole and MDB tests of FMVSS No. 214 during the phase-in period of this final rule. We may also consider rulemaking to incorporate thoracic and abdominal rib deflection

criteria for the SID-IIs in the pole and MDB tests adopted today. By aligning the phase-in schedule of the new MDB requirements with the pole test, more flexibility is provided for the possible implementation of those rulemaking actions.

f. Related Side Impact Programs

1. Out-of-Position Testing

Background. The agency has been concerned about the potential risks of side impact air bags (SIAB) to out-of-position (OOP) occupants, particularly children, from the first appearance of side air bag systems in vehicles. NHTSA initiated research in the fall of 1998 into the interactions between OOP children and side air bags. In April 1999, NHTSA held a public meeting to discuss the potential benefits and risks of side impact air bags and the development of possible test procedures to assess those risks.⁹²

Safety Need. The agency has investigated over 110 side impact air bag deployment crashes through NHTSA's Special Crash Investigations unit in order to determine whether a problem exists related to OOP occupants. There have been no fatalities and only one confirmed AIS 3+ injury due to a side air bag, this to a 76-year-old male driver. Side air bags⁹³ do not appear to pose a safety risk to OOP children, even taking into account exposure risks.

Technical Working Group Recommended Procedures. In July 1999, the Alliance, AIAM, the Automotive Occupant Restraints Council, and IIHS formed a technical working group (TWG) to develop recommended test procedures and performance requirements to evaluate the risk of side air bags to children who are out-of-position. In August 2000, the TWG issued a draft report, "Recommended Procedures For Evaluating Occupant Injury Risk From Deploying Side Air Bags," The Side Air Bag Out-Of-Position Injury Technical Working Group, Adrian K. Lund (IIHS) Chairman, August 8, 2000. This report was revised in July 2003. The proposed procedures were based on the work of Working Group 3 of the International Organization of Standard (ISO) Technical Committee 10, which had

⁹² The agency has placed materials in Docket NHTSA-1999-5098 relating to the risks to out-of-position occupants from SIAB.

⁹³ For the purposes of this discussion, "side air bags" means side thorax air bags and combination thorax/head air bags, and not window curtains or inflatable tubular structures. Our testing found no reason for concern with window curtains or inflatable tubular structures and out-of-position children or adults.

developed draft procedures for evaluating side impact air bags.⁹⁴

Under the TWG procedures, a 5th percentile female side impact dummy (SID-IIs), a 3-year-old and a 6-year-old Hybrid III frontal child dummy are placed in several positions close to the side air bag systems. The TWG procedures address side air bags that deploy from the seat backs (seat-mounted), those that deploy from the door or rear quarter panel, typically just below the window sill (side-mounted), those that deploy from the roof rail above the door (roof-mounted), and roof-rail and seat back/door systems. After the dummy is positioned as specified in the procedures, the air bag is deployed statically, and the dummy injury measures due to the deployment of the air bag are determined. The measured forces are compared to TWG's "Injury Reference Values" and "Injury Research Values."⁹⁵ The TWG's limits on the Injury Reference Values are mostly the same as those in FMVSS No. 208 for OOP testing of frontal air bags.

NHTSA initiated a research program to evaluate the TWG procedures and propose, if necessary, any alternatives and modifications to assess the injury risk to OOP children. The agency's test program included 11 vehicles equipped with front seat side air bags and one vehicle equipped with rear seat side air bags. The TWG OOP test procedures were used as the baseline for selecting test positions. However, tests were performed with the basic TWG procedures with and without NHTSA variations. Many different types of production systems, including door-mounted thorax bags, seat-mounted head-thorax combination bags, and roof-mounted head protection systems, were tested using 3-year-old and 6-year-old Hybrid-III child dummies. The results were reported in a technical paper, "Evaluation of Injury Risk from Side Impact Air Bags." (Proceedings of the 17th ESV Conference, June 2001, Paper # 331.) The main purpose of the test program was to assess the potential safety risks that any system could pose to OOP small adults and children due to deploying side air bags.

The main observations from the agency's research is summarized in the following:

⁹⁴ "Road Vehicles—Test Procedures for Evaluating Occupant Interactions with Deploying Side Impact Airbags." The ISO procedures were finalized in October 2001 (ISO-TR 14933, October 2001).

⁹⁵ Injury Reference values are those that the majority of the TWG believed have a strong scientific basis. Injury Research Values are those that TWG believes currently have less scientific support or insufficient test experience to allow full confidence in their accuracy.

The TWG procedures address dummy sizes, seating positions, and expand the traditional injury assessment measures.

The TWG procedures are quite comprehensive and are very successful at discriminating between aggressive and non-aggressive SIABs.

The TWG procedures are adequate baseline procedures for SIAB OOP testing to minimize unreasonable risks to children and small adults.

For the 3- and 6-year-old dummies, the TWG test procedures do not always find the worst case conditions for some current SIAB systems.

The NPRM. The NPRM sought information on how meeting the requirements proposed by the NPRM would affect manufacturers' ability to meet the TWG procedures. The NPRM stated that the agency will continue to monitor compliance with the TWG test procedures and requirements by automotive manufacturers, and will conduct further testing of new air bag designs.

Comments: DaimlerChrysler commented that at this time, it does not know the extent of which the OOP occupants, as specified in the TWG, would be affected by the proposed requirements in the NPRM. However, DaimlerChrysler anticipated that side air bags designed in accordance to the NPRM may be in conflict with the TWG OOP requirements. Conversely, TRW believed that the side protection systems designed to meet the requirements of the NPRM could perform acceptably for OOP occupants. TRW also stated that it supports the efforts of the OOP TWG and does not believe there is a need for regulatory activity in this area.

Agency response: We have considered the comments on whether meeting the requirements proposed by the NPRM would affect manufacturers' ability to meet the TWG procedures. DaimlerChrysler, the only vehicle manufacturer commenting on this issue, stated it had no data to support its suggestion of a potential conflict between TWG and the proposed requirements of the NPRM, but anticipated there may be some.

NHTSA's testing has shown that, during the course of the 214 fleet testing program, there have been vehicles that have met the new requirements of this final rule and have also been reported to meet the TWG procedures. The Jetta, Volkswagen Beetle Convertible, Saab 9-3 Convertible and Honda Accord have met the pole test injury criteria with the ES-2re and have been certified by their respective manufacturer to the TWG OOP requirements. The Honda CRV met the pole test criteria with the SID-IIIs

and also has been certified to TWG OOP. These examples show that the oblique pole and MDB test requirements are not in conflict with the TWG guidelines. Further, air bag supplier TRW stated that side impact protection systems designed to meet the requirements of the NPRM could perform acceptably for OOP occupants. Based on the available information, we conclude that vehicles are able to meet the requirements of this final rule and those of the TWG OOP.

The agency monitors compliance with the TWG requirements by vehicle manufacturers. As part of the agency's Buying a Safer Car consumer information program, we publish whether a vehicle was certified to the TWG OOP requirements. We only state that a vehicle has met those requirements after the manufacturer has provided data showing that it conforms to TWG OOP. The agency also conducts spot testing to verify those results. If the knowledge we gain from our test program indicates that further actions are needed, we will take appropriate actions to do so.

2. Side NCAP

Honda asked that NHTSA use WorldSID in testing vehicles under the side impact new car assessment program if the manufacturer uses WorldSID for that vehicle's FMVSS No. 214 certification. Autoliv wanted NHTSA to address the effects of the rulemaking on NCAP. "If there is a significant difference between Lateral NCAP and FMVSS 214 (MDB) test conditions and requirements, there may be significant challenges in meeting requirements of both (potentially conflicting) test conditions."

Agency response: We have carefully considered Honda's suggestion. However, since we are not engaged in a rulemaking action on the WorldSID dummy at the present time, we can only commit to study the merit of Honda's suggestion during the course of our future research.

In response to Autoliv, we do not anticipate significant challenges or potential conflicts in meeting the requirements of both side NCAP and the final rule. The upgrade to FMVSS No. 214 is an enhancement to the protection currently provided by the standard. Based on our crash testing to date, vehicles that achieved a rating of four stars or better for both occupants in side NCAP tests will likely be among the better performers in meeting the requirements of the final rule. (The FMVSS No. 214 test is conducted at a lower speed than the side NCAP test.) We believe countermeasures, such as

new side structure enhancements, new crash sensors and/or algorithms, and/or new head protection systems, will only improve a vehicle's performance in side NCAP and other side impact crashes.

Nonetheless, NHTSA carefully ensures that any changes to NCAP are based on sound science and careful, objective analysis of supporting data.⁹⁶ With the two new crash test dummies and a new crash test configuration added to the standard, the agency will continue to evaluate how to tailor the side NCAP program to complement the upgraded requirements of FMVSS No. 214.

3. Cross-References to FMVSS No. 214

Honda pointed out that FMVSS Nos. 201, 301 and 305 contain cross-references to sections of FMVSS No. 214 that will be renumbered by this final rule. We are amending those cross-references in FMVSS Nos. 201, 301 and 305 to achieve consistency with today's final rule.

g. Comments on the PEA

Several comments were received on the agency's preliminary economic assessment (PEA) for the NPRM. Commenters included Maserati and Ferrari, the Alliance, and the Specialty Equipment Manufacturers Association (SEMA).

Maserati and Ferrari believed that NHTSA underestimated the costs of small manufacturers to comply with the proposed rule. The Alliance had questions about how the PEA estimated the benefits of the rulemaking, e.g., how the agency identified the target population of potentially injured occupants that would be addressed by the rulemaking. The Alliance also believed that we did not demonstrate the practicability of meeting the proposed test requirements, and stated that the principles set forth in the Data Quality Act were not met (the commenter believed that some of the data in the PEA had errors and that the PEA contained some unsupported assumptions).

The agency has responded to the comments on the costs and benefits analysis and other issues of the PEA in the Final Regulatory Impact Analysis (FRIA)⁹⁷ (see Appendix G of the FRIA),

⁹⁶ NHTSA has announced plans to evaluate near and long-term approaches to enhance NCAP activities. "The New Car Assessment Program; Suggested Approaches for Enhancements," 72 FR 3473; January 25, 2007, Docket 26555. An enhancement under consideration is to include the pole test in NCAP assessments.

⁹⁷ The FRIA may be obtained by contacting Docket Management at the address or telephone number provided at the beginning of this document. You may also read the document via the Internet,

which has been placed in the agency's docket for this final rule.

VII. Costs and Benefits

As noted above, we have prepared an FRIA to accompany this final rule. The FRIA provides an analysis of the potential impacts of the vehicle-to-pole side impact test and the modifications to the MDB test. It also addresses comments the agency received in response to the agency's Preliminary Economic Assessment that accompanied the NPRM. A summary of the FRIA follows.

Benefits. The agency identified the baseline target population and then estimated the fatality or injury reduction rate. The target population was defined as occupants who sustained fatal and/or AIS 3+ injuries to the head, chest, abdomen or pelvis in side crashes. Target fatalities and MAIS 3–5 injuries were derived from 2000–2004 CDS. The agency limited the target population to crashes in which the delta-V was in the range of 19 to 40 km/h (12 to 25 mph). In identifying the target population, occupants with heights of 165 cm (65 inches) or taller were assumed to be represented by the 50th percentile male dummy (the ES–2re), and the remaining occupants were assumed to be

represented by the 5th percentile female dummy (the SID–IIs). As discussed in the FRIA, several additional adjustments were made to the target population to address voluntary commitments, belt use, children, etc. The target population was then determined to be 2,311 fatalities and 5,891 non-fatal serious to critical MAIS AIS 3–5 injuries in crashes with a delta-V of 19 to 40 km/h (12–25 mph) for near-side occupants.⁹⁸ The 2,311 fatalities were divided into two groups for the analysis: (1) Vehicle-to-pole impacts; and (2) vehicle-to-vehicle or other roadside object impacts, which include partial ejections in these cases. Further adjustments were made for assumed full compliance with the FMVSS No. 201 upper interior requirements, 100 percent Electronic Stability Control (ESC) penetration in the model year (MY) 2011 new vehicle fleet, current performance that conforms to the final rule requirements adopted today (based on the results of the NHTSA 214 fleet testing program), and manufacturers' planned installation of side air bags.⁹⁹ The incremental benefits of the final rule are estimated as:

—266 fatalities saved and 352 AIS 3–5 injuries prevented, if a combination

air bag, 2-sensor per vehicle system were used. (The combination air bag, 2-sensor system would be the least costly side air bag system that would enable a vehicle to meet the standard.)

—311 fatalities saved and 361 MAIS 3–5 injuries prevented, if a window curtain and thorax air bag 2-sensor system were used.

—311 fatalities saved and 371 MAIS 3–5 injuries prevented, if a window curtain and thorax air bag 4-sensor system were used.

Window curtains are estimated to have more benefits than combination air bags because we assumed that window curtains would have an impact on partial ejections that occur in side impacts without rollover, while we assume no benefits for combination air bags in far-side partial ejections without rollover. No benefits are claimed for complete ejections in rollovers, since the effectiveness of the combination air bags or window curtains to contain occupants in a rollover event has not been established at this time.

The majority of the benefits are for front seat occupants, but a small number of benefits are included for rear seat occupants.

TABLE 13.—BENEFITS OF THE FINAL RULE BY COUNTERMEASURE ¹⁰⁰

	Combination air bag 2 sensors	Curtain & thorax bags 2 sensors	Curtain & thorax bags 4 sensors
Fatalities	266	311	311
AIS 3–5 Injuries	352	361	371

Costs. In the FRIA, the agency discusses the costs of the different technologies that could be used to comply with the tests, and also estimates compliance tests costs. Based on the results of the 2005 tests of vehicles with side air bags (Section IV of this preamble, *supra*), the agency estimates that the majority of vehicle manufacturers currently installing side head air bag systems will have to widen their present air bags. They might not need to add side impact sensors to their vehicles or develop more advanced sensors to meet an oblique pole test.

Potential compliance costs for the pole test vary considerably, and are dependent upon the types of head and thorax side air bags chosen by the manufacturers and the number of sensors used in the system. As noted above, NHTSA estimates that the combination air bag, 2-sensor system would be the least costly side air bag system that would enable a vehicle to meet the standard.

The costs for installing new systems are estimated to range from:

—a wide combination head/thorax side air bag system with two sensors at \$126 per vehicle,

—to wide window curtains and wide thorax side air bags with four sensors at a cost of \$280 per vehicle.

Given the level of compliance found in our vehicle testing ¹⁰¹ and the manufacturers' planned installation of side air bags in MY 2011, the total annual incremental cost to meet this final rule with the lower cost combination air bag is estimated to be \$429 million. The total annual incremental cost for the wide window

by following the instructions in the section below entitled, "Viewing Docket Submissions." The FRIA will be listed in the docket summary.

⁹⁸ The Agency's analysis also found some fatality benefits for far-side unbelted occupants. In 2004 FARS, there were 1,441 unbelted far-side occupant fatalities in side impacts.

⁹⁹ Seven manufacturers (comprising about 90 percent of all light vehicle sales) submitted confidential data responding to a NHTSA request for planned side air bag and projected sales through

model year (MY) 2011. For remaining manufacturers, MY 2006 side air bag percentages were assumed to remain constant through MY 2011. The projected MY 2011 side air bag sales data show that the majority of vehicles (about 93%) will be equipped with side air bags. Based on the sales data, we expect that about 95% and 78% of these vehicles will be equipped with curtain and thorax bags, respectively.

¹⁰⁰ The benefits of 100 percent of the fleet having side air bags compared to 0 percent of the fleet

having side air bags, assuming 100 percent of vehicles have Electronic Stability Control systems, are estimated to be 976 fatalities and 932 AIS 3–5 injuries.

¹⁰¹ We assumed that the performance of side air bags that would have been installed in MY 2011 vehicles in the absence of the oblique pole test requirements would have been equivalent to the performance observed in the agency's tests of MY 2005 vehicles.

curtains and wide thorax side air bags with four sensors is estimated to be \$1.1 billion (2004 dollars). This amounts to a range of total incremental annual cost of \$429 million to \$1.1 billion.

The agency's data show that the majority of side air bag systems are currently equipped with two side impact sensors. The total annual incremental cost for the most likely air

bag system (curtain and thorax bag two-sensor countermeasure) would be about \$560 million.

TABLE 14.—INCREMENTAL TOTAL COSTS AND VEHICLE COSTS
[2004]

	Combination head/thorax side air bags	Window curtain and thorax side air bags, 2 sensors	Window curtain and thorax side air bags, 4 sensors
Incremental total costs	*\$429	*\$560	**\$1.1
Total vehicle cost per system	126	243	280

*Million.
**Billion.

Cost Per Equivalent Fatality Prevented. NHTSA estimated the costs per equivalent life saved, using a 3 and a 7 percent discount rate. The low end of the range is \$1.6 million per equivalent life saved, using a 3 percent discount rate. That low end estimate

assumes that manufacturers will install combination head/thorax air bags rather than separate window curtains and thorax air bags, in vehicles that currently have no side impact air bags or only thorax side impact air bags. The high end of the range is \$4.6 million per

equivalent life saved, using a 7 percent discount rate. The high end estimate assumes that manufacturers will install separate window curtains and thorax air bags with four sensors.

TABLE 15.—COSTS PER EQUIVALENT LIFE SAVED PRESENT DISCOUNTED VALUE
[in millions]

Cost per equivalent life saved	Combination head/thorax side air bags	Window curtain and thorax side air bags, 2 sensors	Window curtain and thorax side air bags, 4 sensors
3% Discount Rate	\$1.6	\$1.8	\$3.7
7% Discount Rate	2.0	2.3	4.6

Net Benefits. Net benefit analysis differs from cost effectiveness analysis in that it requires that benefits be assigned a monetary value, and that this value is compared to the monetary value

of costs to derive a net benefit. NHTSA estimates that the high end of the net benefits is \$561 million for the combination head/thorax air bags using a 3 percent discount rate and the low

end is negative \$225 million for the curtain + thorax bags with four sensors, using a 7 percent discount rate. Both of these are based on a \$3.7 million cost per equivalent life saved.

TABLE 16.—NET BENEFITS WITH \$3.7M COST PER LIFE
[In millions]

Countermeasure	Benefit		Net benefit	
	3% discount	7% discount	3% discount	7% discount
Combo + 2 Sensors	\$990	\$787	\$561	\$357
Curtain + 2 Sensors	1,127	895	567	336
Curtain + 4 Sensors	1,131	899	7	-225

VIII. Rulemaking Analyses and Notices

a. Executive Order 12866 (Regulatory Planning and Review) and DOT Regulatory Policies and Procedures

The agency has considered the impact of this rulemaking action under Executive Order 12866 and the Department of Transportation's regulatory policies and procedures. This rulemaking is economically significant and was reviewed by the Office of Management and Budget under E.O.

12866, "Regulatory Planning and Review." The rulemaking action has also been determined to be significant under the Department's regulatory policies and procedures. The FRIA fully discusses the estimated costs and benefits of this rulemaking action. The costs and benefits are summarized in section VII of this preamble, *supra*.

b. Regulatory Flexibility Act

The Regulatory Flexibility Act of 1980, as amended, requires agencies to

evaluate the potential effects of their proposed and final rules on small businesses, small organizations and small governmental jurisdictions. I hereby certify that this rule will not have a significant economic impact on a substantial number of small entities. Small organizations and small governmental units will not be significantly affected since the potential cost impacts associated with this action

will not significantly affect the price of new motor vehicles.

The rule will directly affect motor vehicle manufacturers. NHTSA requested comments on an addendum to the initial regulatory flexibility analysis (IRFA) that was contained in the Preliminary Economic Assessment (PEA) for the May 17, 2004 NPRM on FMVSS No. 214 (Docket No. 17694). The addendum to the IRFA discusses the economic impacts on small vehicle manufacturers, of which there are four¹⁰² (70 FR 2105; January 12, 2005).

NHTSA stated in the addendum that our tentative conclusion was that the rule will not have a significant economic impact on the four manufacturers. We believed that the small vehicle manufacturers are not likely to certify compliance with a vehicle test, but will use a combination of component testing by air bag suppliers and engineering judgment. Already much of the air bag work for these small vehicle manufacturers is done by air bag suppliers. Typically, air bag suppliers are supplying larger vehicle manufacturers during the development and phase-in period, and do not have the design capabilities to handle all of the smaller manufacturers. The rulemaking proposal accounted for this limitation by proposing to allow small manufacturers that have limited lines to comply with the upgraded requirements at the end of the phase-in period, to reduce the economic impact of the rule on these small entities.

As explained in the addendum, we also believed that the rulemaking would not have a significant impact on the small vehicle manufacturers because the market for the vehicles produced by these entities is highly inelastic. Purchasers of these vehicles are attracted by the desire to have an unusual vehicle. Further, all light vehicles must comply with the upgraded side impact requirements. Since the price of complying with the rule will likely be passed on to the final consumer, the price of competitor's models will increase by similar amounts. In addition, we did not believe that raising the price of a vehicle to include the value of a combination head-thorax side air bag will have much, if any, effect on vehicle sales.

The agency received no comments on the addendum to the IRFA concerning the impacts of the rule on small vehicle manufacturers.

For the reasons explained in the IRFA, NHTSA concludes that this final rule will not have a significant impact on small vehicle manufacturers.

The final rule indirectly affects air bag manufacturers, dummy manufacturers and seating manufacturers. The agency does not believe that there are any small manufacturers of air bags. There are several manufacturers of dummies and/or dummy parts, some of which are considered small businesses. The rule is expected to have a positive impact on these types of small businesses by increasing demand for dummies.

NHTSA knows of approximately 21 suppliers of seating systems, about half of which are small businesses. If seat-mounted head/thorax air bags are used to meet the new pole test, the cost of the seats will increase. However, we believe that the costs will be passed on to the consumer. NHTSA believes that air bag manufacturers will provide the seat suppliers with the engineering expertise necessary to meet the new requirements.

NHTSA notes that final-stage vehicle manufacturers and alterers buy incomplete vehicles, add seating systems to vehicles without seats, and/or make other modifications to the vehicle, such as replacing existing seats with new ones or raising the roofs of vehicles. A second-stage manufacturer or alterer modifying a vehicle with a seat-mounted thorax air bag might need to use the existing seat or rely on a seat manufacturer to provide the necessary technology. In either case, the impacts of this final rule on such entities will not be significant. Final-stage manufacturers or alterers engaged in raising the roofs of vehicles will not be affected by this rulemaking, since this final rule excludes vehicles with raised or altered roofs from the pole test.

The Specialty Equipment Market Association (SEMA) believed that "aftermarket equipment manufacturers and other entities that diagnose, service, repair and upgrade motor vehicles" may be affected by the final rule if their installed products interact with equipment or systems used by vehicle manufacturers to meet the FMVSS No. 214 requirements. SEMA's comment focused on three issues. The following discusses those comments and our responses thereto.

1. SEMA said that, with regard to frontal air bags and air bag sensors installed pursuant to FMVSS No. 208, "Occupant crash protection," manufacturers of aftermarket leather and fabric seating products frequently have not had access to electronic information about the frontal air bag sensor in the vehicle seat. Consequently, SEMA stated, the aftermarket manufacturer or installer could not reprogram the sensor after the product has been installed, and in many instances, had to return the vehicle to

the dealership for reprogramming. SEMA suggested that NHTSA should—make sure that electronic data is open and available in such a way so as not to preclude installation, servicing, or repair of legal aftermarket equipment * * *. Specifically, SEMA believes it is appropriate to follow the EPA [Environmental Protection Agency] OBD [on-board diagnostic system] precedent in that any and all electronic data, or any that can be accessed through the available technology, must be made available to the vehicle owner to the extent that such access is available to other parties. Further, SEMA believes it is appropriate that NHTSA consider setting standards for data retrieval communication protocols, connectors and tools, and that such information and tools be made available to the public in a timely and cost-effective manner.

Agency response: Requiring vehicle manufacturers to ensure that electronic information about the SIABs is "open and available * * *" so as not to preclude installation, servicing, or repair" of aftermarket equipment is beyond the scope of this rulemaking. Furthermore, we do not have any information showing that such a requirement is necessary or appropriate at this time. Vehicles currently include many complex systems, and although dealer involvement may be necessary in some cases, the marketplace has made available sufficient information to permit convenient maintenance and repair of such systems. We do not believe that SIAB technology will prove any different in this regard. There are a substantial number of vehicles currently equipped with SIAB systems—some portion of which it is expected would have had aftermarket modifications of the types suggested by SEMA—and there has been no indication of any problem to date. Additional information may become available in the future that sheds light on how SIAB systems interact with other vehicle equipment and systems. We will monitor the data and test information we receive on this issue, and we encourage all interested parties to share relevant information with the agency and the public as it becomes available. If we later find significant safety risks associated with the interaction between SIAB systems and items of equipment (aftermarket or otherwise), we will work toward addressing these possible problems.

Further, we are not requiring vehicle manufacturers to share all electronic data with the vehicle owner. Such a requirement is unnecessary at this time, for the reasons discussed above. We have not been presented with any evidence of a safety or compatibility problem between SIABs and other vehicle systems or equipment, and the

¹⁰² Avanti, Panoz, Saleen, and Shelby.

market has tended to respond to consumer demands that sufficient information be provided to permit third party vehicle servicing. Nonetheless, NHTSA strongly encourages SEMA and its members to develop relationships with vehicle and SIAB system manufacturers to research and find solutions to these questions.

2. SEMA stated that “many dealerships have received service bulletins from the vehicle manufacturer warning them against the installation of aftermarket seat covers, citing concern that installation may interfere with the front seat airbag sensors.” SEMA suggested that NHTSA should “issue a regulation or policy statement which states that it is illegal to issue service bulletins or other communications that warn dealers about potential warranty denial based on the mere presence or installation of aftermarket equipment.”

Agency response: We are unable to concur with SEMA that NHTSA should provide the requested regulation and/or policy statement governing the communications between manufacturers and dealers on warranties.

Communications between vehicle manufacturers and their dealers on the warranties is a topic that is beyond the scope of the rulemaking. However, we encourage OEMs and the aftermarket sales industry to work together to share information on the effect of aftermarket equipment on vehicle warranties.

3. SEMA believed that NHTSA did not consider all of the small businesses potentially impacted by the final rule. The commenter believed that the rule “will directly affect a number of small entities including manufacturers and installers of seating equipment, interior upholstery, sunroofs and running boards. Beyond that, there are potentially thousands of small entities that may have the opportunity to diagnose, service, repair and upgrade motor vehicles.” SEMA stated, “While it may be possible to work with the air bag manufacturers to design seating equipment, upholstery, sunroofs, running boards and other items of equipment that may effect [sic] air bag sensors, the information is of little value if the vehicle’s computer system needs to be reprogrammed to accommodate the new equipment. The reg-flex analysis does not take into account that the vehicle manufacturers are the source of this information, not the air bag manufacturers. Unless such service information is forthcoming, thousands of small businesses may be directly impacted by the rule change.”

Agency response: In responding to this comment, we note that NHTSA is not required to perform a regulatory

flexibility analysis for entities not directly impacted by its rulemaking. In its 2003 publication titled “A Guide for Government Agencies: How to Comply with the Regulatory Flexibility Act” (“RFA Guide”), the Small Business Administration states that “[t]he courts have held that the RFA requires an agency to perform a regulatory flexibility analysis of small entity impacts only when a rule directly regulates them.”¹⁰³ The cases cited by the RFA Guide indicate that a rule “directly regulates” only the entities to which the rule applies—for example, electric utilities but not independent electricity cooperatives in a FERC rate-setting regulation,¹⁰⁴ or automobile manufacturers but not aftermarket businesses in an EPA ‘deemed-to-comply’ rule.¹⁰⁵ In *Motor & Equipment Mfrs. Ass’n v. Nichols*, the D.C. Circuit described the distinction as follows: “The RFA itself distinguishes between small entities subject to an agency rule, to which its requirements apply, and those not subject to the rule, to which the requirements do not apply.”¹⁰⁶

This final rule establishes performance requirements for side impact protection and applies to new motor vehicles. The only entities subject to these requirements are vehicle manufacturers. NHTSA has already analyzed the potential impacts of the rule on these directly affected entities, as the FRIA makes clear. Nothing in this rule subjects the entities described by SEMA to NHTSA’s regulation.

With that said, although NHTSA has no obligation to perform a regulatory flexibility analysis to consider the potential impacts of this final rule on such non-directly regulated entities, we are nevertheless concerned about the impact our rules have on all parties. Again, we have considered the effects that this final rule might have on aftermarket motor vehicle equipment manufacturers and the motor vehicle

¹⁰³ Office of Advocacy, United States Small Business Administration, “A Guide for Government Agencies: How to Comply with the Regulatory Flexibility Act,” 2003, p. 20.

¹⁰⁴ *Mid-Tex Electric Cooperative, Inc. v. Federal Energy Regulatory Commission (FERC)*, 773 F.2d 327, 341 (DC Cir. 1985) (stating that “Congress did not intend to require that every agency consider every indirect effect that any regulation might have on small businesses in any stratum of the national economy.”).

¹⁰⁵ *Motor & Equipment Mfrs. Ass’n v. Nichols*, 142 F.3d 449, 467 (DC Cir. 1998) (holding that “Because the deemed-to-comply rule did not subject any aftermarket businesses to regulation, EPA was not required to conduct a flexibility analysis as to small aftermarket businesses. It was only obliged to consider the impact of the rule on small automobile manufacturers subject to the rule, and it met that obligation.”).

¹⁰⁶ *Id.*, fn 18, at 467 (describing 5 U.S.C. 603(b)(3) and (4)).

service industry. The agency is not aware of any significant compatibility problems between SIAB systems and other vehicle equipment, and SEMA provided no evidence that side air bag technology will preclude installation, servicing, or repair of aftermarket equipment, including whether and the degree to which particular aftermarket modifications of a vehicle entail the reprogramming of a vehicle’s computer system. The agency cannot hypothesize on all possible interactions between SIAB technologies and different vehicle equipment, and we are unable to address speculative arguments regarding compatibility problems for which there is no evidence. There are a substantial number of vehicles currently equipped with SIAB systems—some portion of which it is expected would have had aftermarket modifications of the types suggested by SEMA—and there has been no indication of any problem to date.

Nonetheless, we encourage manufacturers of aftermarket equipment that cannot independently assess whether their products will affect original SIAB systems to collaborate with air bag and vehicle manufacturers to make that assessment or to undertake concerted testing to develop products that are compatible with the SIABs. SEMA’s comment indicated that companies that supply leather or fabric seating already “have tested their products to ensure that the leather or fabric does not adversely impact the air bag seat sensors.”¹⁰⁷ We believe that the aftermarket installers of other products can likewise embark on testing or collaborative work with air bag and vehicle manufacturers to ensure that the installation is compatible with the vehicles’ SIAB systems.

Further, aftermarket businesses have already been servicing vehicles with SIABs and other complex systems that use computer technology. Although vehicle dealer involvement may be necessitated in some cases, we do not believe that involvement has resulted in a significant economic impact on the businesses. The marketplace has generally made available sufficient information to permit the aftermarket installation of equipment, and the maintenance and repair of vehicles with SIAB and other systems. There is no indication that vehicle manufacturers and dealers have not made and will not continue to make necessary information reasonably available to the aftermarket sales and service industries. However,

¹⁰⁷ See also submission from Kugi Florian in NHTSA Docket 17694 (Walser aftermarket seat cover made compatible with seat-mounted side air bags).

we will continue to monitor the data and test information we receive on this issue, and we encourage all interested parties to share relevant information with the agency and the public as it becomes available. If we later find problems with the information being made available to the aftermarket sales and service industries, we will take appropriate steps to address these problems.

For the aforementioned reasons, we conclude that this rule will not have a significant negative economic impact on a substantial number of small entities.¹⁰⁸

c. Executive Order 13132 (Federalism)

NHTSA has examined today's final rule pursuant to Executive Order 13132 (64 FR 43255, August 10, 1999) and concluded that no additional consultation with States, local governments or their representatives is mandated beyond the rulemaking process. The agency has concluded that the rule does not have federalism implications because the rule does not have "substantial direct effects on the States, on the relationship between the national government and the States, or on the distribution of power and responsibilities among the various levels of government."

Further, no consultation is needed to discuss the preemptive effect of today's rule. NHTSA rules can have preemptive effect in at least two ways. First, the National Traffic and Motor Vehicle Safety Act contains an express preemptive provision: "When a motor vehicle safety standard is in effect under this chapter, a State or a political subdivision of a State may prescribe or continue in effect a standard applicable to the same aspect of performance of a motor vehicle or motor vehicle equipment only if the standard is identical to the standard prescribed under this chapter." 49 U.S.C. 30103(b)(1). It is this statutory command that preempts State law, not today's rulemaking, so consultation would be inappropriate.

In addition to the express preemption noted above, the Supreme Court has also recognized that State requirements imposed on motor vehicle manufacturers, including sanctions imposed by State tort law, can stand as an obstacle to the accomplishment and execution of a NHTSA safety standard. When such a conflict is discerned, the Supremacy Clause of the Constitution makes their State requirements

unenforceable. See *Geier v. American Honda Motor Co.*, 529 U.S. 861 (2000). NHTSA has not outlined such potential State requirements in today's rulemaking, however, in part because such conflicts can arise in varied contexts, but it is conceivable that such a conflict may become clear through subsequent experience with today's standard and test regime. NHTSA may opine on such conflicts in the future, if warranted. See *id.* at 883–86.

d. Unfunded Mandates Reform Act

The Unfunded Mandates Reform Act of 1995 (UMRA) requires Federal agencies to prepare a written assessment of the costs, benefits and other effects of proposed or final rules that include a Federal mandate likely to result in the expenditure by State, local or tribal governments, in the aggregate, or by the private sector, of more than \$100 million annually (adjusted annually for inflation, with base year of 1995). These effects are discussed earlier in this preamble and in the FRIA. UMRA also requires an agency issuing a final rule subject to the Act to select the "least costly, most cost-effective or least burdensome alternative that achieves the objectives of the rule."

The preamble and the FRIA identify and consider a number of alternatives, concerning factors such as test speed, test angle, number and type of dummies used in the test, and phase-in schedule. Alternatives considered by and rejected by us would not fully achieve the objectives of the alternative preferred by NHTSA (a reasonable balance between the benefits and costs of a 20 mph oblique pole test with the ES-2re and the SID-IIs, and a reasonable balance of the benefits and costs of an upgrade of the MDB test). Further, Section IX of the FRIA discusses three alternative regulatory approaches to the oblique pole test that we considered: (a) Using the 90 degree pole test set forth in FMVSS No. 201; (b) using the Voluntary Commitment approach (perpendicular moving barrier test with one test dummy); and (c) applying a pole test to front and rear seats. The agency believes that it has selected the most cost-effective alternative that achieves the objectives of the rulemaking.

e. National Environmental Policy Act

NHTSA has analyzed this final rule for the purposes of the National Environmental Policy Act. The agency has determined that implementation of this action will not have any significant impact on the quality of the human environment.

f. Executive Order 12778 (Civil Justice Reform)

With respect to the review of the promulgation of a new regulation, section 3(b) of Executive Order 12988, "Civil Justice Reform" (61 FR 4729, February 7, 1996) requires that Executive agencies make every reasonable effort to ensure that the regulation: (1) Clearly specifies the preemptive effect; (2) clearly specifies the effect on existing Federal law or regulation; (3) provides a clear legal standard for affected conduct, while promoting simplification and burden reduction; (4) clearly specifies the retroactive effect, if any; (5) adequately defines key terms; and (7) addresses other important issues affecting clarity and general draftsmanship under any guidelines issued by the Attorney General. This document is consistent with that requirement.

Pursuant to this Order, NHTSA notes as follows. The preemptive effect of this rule is discussed above. NHTSA notes further that there is no requirement that individuals submit a petition for reconsideration or pursue other administrative proceeding before they may file suit in court.

g. Plain Language

Executive Order 12866 requires each agency to write all rules in plain language. Application of the principles of plain language includes consideration of the following questions:

- Have we organized the material to suit the public's needs?
- Are the requirements in the rule clearly stated?
- Does the rule contain technical language or jargon that isn't clear?
- Would a different format (grouping and order of sections, use of headings, paragraphing) make the rule easier to understand?
- Would more (but shorter) sections be better?
- Could we improve clarity by adding tables, lists, or diagrams?
- What else could we do to make the rule easier to understand?

If you have any responses to these questions, please write to us with your views.

h. Paperwork Reduction Act (PRA)

Under the PRA of 1995, a person is not required to respond to a collection of information by a Federal agency unless the collection displays a valid OMB control number. The final rule contains a collection of information because of the proposed phase-in reporting requirements. There is no burden to the general public.

¹⁰⁸ Additional information concerning the potential impacts of the requirements on small entities is presented in the FRIA.

The collection of information requires manufacturers of passenger cars and of trucks, buses and MPVs with a GVWR of 4,536 kg (10,000 lb) or less, to annually submit a report, and maintain records related to the report, concerning the number of such vehicles that meet the vehicle-to-pole and MDB test requirements of FMVSS No. 214 during the phase-in of those requirements. The phase-in of both the pole and MDB test requirements will cover three years. The purpose of the reporting and recordkeeping requirements is to assist the agency in determining whether a manufacturer of vehicles has complied with the requirements during the phase-in period.

We are submitting a request for OMB clearance of the collection of information required under today's final rule. These requirements and our estimates of the burden to vehicle manufacturers are as follows:

NHTSA estimates that there are 21 manufacturers of passenger cars, multipurpose passenger vehicles, trucks, and buses with a GVWR of 4,536 kg (10,000 lb) or less;

NHTSA estimates that the total annual reporting and recordkeeping burden resulting from the collection of information is 1,260 hours;

NHTSA estimates that the total annual cost burden, in U.S. dollars, will be \$0. No additional resources will be expended by vehicle manufacturers to gather annual production information because they already compile this data for their own use.

A **Federal Register** document has provided a 60-day comment period concerning the collection of information. The Office of Management and Budget (OMB) promulgated regulations describing what must be included in such a document. Under OMB's regulations (5 CFR 320.8(d)), agencies must ask for public comment on the following:

(1) Whether the collection of information is necessary for the proper performance of the functions of the agency, including whether the information will have practical utility;

(2) The accuracy of the agency's estimate of the burden of the proposed collection of information, including the validity of the methodology and assumptions used;

(3) How to enhance the quality, utility, and clarity of the information to be collected; and,

(4) How to minimize the burden of the collection of information on those who are to respond, including the use of appropriate automated, electronic, mechanical, or other technological collection techniques or other forms of

information technology, e.g., permitting electronic submission of responses.

The NPRM requested that organizations and individuals wishing to submit comments on the information collection requirements direct them to the docket for the NPRM. The agency did not receive any comments on the information collection requirements.

i. National Technology Transfer and Advancement Act

Under the National Technology Transfer and Advancement Act of 1995 (NTTAA) (Pub. L. 104-113),

all Federal agencies and departments shall use technical standards that are developed or adopted by voluntary consensus standards bodies, using such technical standards as a means to carry out policy objectives or activities determined by the agencies and departments.

Voluntary consensus standards are technical standards (e.g., materials specifications, test methods, sampling procedures, and business practices) that are developed or adopted by voluntary consensus standards bodies, such as the International Organization for Standardization (ISO) and the Society of Automotive Engineers. The NTTAA directs us to provide Congress, through OMB, explanations when we decide not to use available and applicable voluntary consensus standards.

When NHTSA developed the vehicle-to-pole test that was adopted into FMVSS No. 201, the agency based the test on a proposed ISO test procedure found in ISO/SC10/WG1 (October 2001). In developing today's final rule, we considered the draft ISO standard and ISO draft technical reports related to side air bags performance to guide our decision-making to the extent consistent with the Safety Act. The notable differences between the draft ISO standard and this final rule relate to: the diameter of the pole (ISO draft technical reports recommend the use of a 350 mm pole, while NHTSA uses a 254 mm pole in FMVSS No. 201 and will use such a pole in FMVSS No. 214), and the angle of approach of the test vehicle to the pole (ISO specifies 90 degrees, while our final rule uses a 75 degree angle). The agency's reasons for a 254 mm pole were discussed in the NPRM. The reasons for an oblique, 32 km/h (20 mph), angle of approach were discussed earlier in this document.

IX. Appendices

Appendix A—Glossary

Categories of Side Air Bags

Combined (also called "integrated," "combination" or "combo") side air bag system. Incorporates both a head air bag

system and a torso side air bag into one unit that is typically installed in the seat back.

Curtain. A "curtain" type side air bag system (referred to as "curtain bags," "side curtain air bags," "window curtains," "air curtains," or "AC"). A curtain is an inflatable device that is fixed at two points, one at the front end of the vehicle's A-pillar and the other along the roof rail near the C-pillar. It is installed and stored un-deployed under the roof rail headliner. When deployed, the curtain inflates to provide a cushioned contact surface for the head, spanning the side of the vehicle, down from the roof rail across the windows. This system would provide head protection for front and possibly rear seat occupants in outboard seating positions in side crashes.

Head air bag system (or head protection system (HPS)). The term comprises different types of head protection systems, such as curtain bags, installed either as a stand alone system or combined with a thorax side air bag.

Side impact air bag (SIAB). The term refers to side air bags generally.

Torso (or thorax) side air bag. A "torso" (or "thorax") side air bag that can be installed in either the seat back or the vehicle door. As the name indicates, the system would provide protection for the torso but not for the head.

Appendix B—Existing FMVSS No. 214

FMVSS No. 214 specifies two types of performance requirements intended to protect the thoracic and pelvic regions of an occupant: "quasi-static" requirements and "dynamic" requirements. They apply to passenger cars and to multipurpose passenger vehicles, trucks, and buses with a GVWR of 4,536 kg (10,000 lb) or less and 6,000 lb or less, respectively.

The quasi-static requirements limit the extent to which the side door structure of a vehicle is pushed into the passenger compartment during a side impact. The standard requires each side door to resist crush forces that are applied by a piston pressing a 300 mm (12 inch) steel cylinder against the door's outer surface in a laboratory test. Since the requirement became effective in 1973, vehicle manufacturers have generally chosen to meet the requirement by reinforcing the side doors with metal beams.

The dynamic side impact test currently regulates the level of crash forces that can be experienced by an occupant's chest and pelvis when seated in a vehicle struck in a side impact. The dynamic requirements focus on thoracic and pelvic protection because contact

between the thorax and the side interior has been the primary source of serious injuries and fatalities.

The dynamic side impact test simulates a 90-degree intersection impact of a striking vehicle traveling 48 km/h (30 mph) into a target (i.e., test) vehicle traveling 24 km/h (15 mph). This is achieved by running a moving deformable barrier (MDB), which has all wheels rotated 27 degrees (crab angle) from the longitudinal axis, into the side of a stationary (test) vehicle at a 90-degree contact angle with a 54 km/h (33.5 mph) closing speed. At the initial contact, the longitudinal axes of the MDB and the test vehicle are perpendicular to each other. Two 50th percentile adult male side impact dummies (SIDs) are used in the target

vehicle. They are positioned on the struck side of the vehicle, one in the front seat with the other directly behind in the rear seat.

The MDB, which simulates the striking (i.e., bullet) vehicle, has a mass of 1,361 kilograms (kg) (3,000 lb). The weight of the MDB and the geometry and material properties of the MDB's aluminum honeycomb contact face were derived from an adjustment of the average properties of the vehicle fleet (passenger cars and LTVs) in existence at the time of the development of the dynamic side impact regulation.

The test procedures focus on the dummy's chest and pelvis acceleration responses, which have been correlated with crash and test data regarding the conditions that produce serious

occupant injuries. The instrumented dummies must not exhibit chest accelerations and pelvic accelerations above specified thresholds in order to pass the test. The maximum rib and spine accelerations measured on the chest are averaged into a single metric called the Thoracic Trauma Index (TTI(d)), which has an 85g limit for 4-door vehicles and a 90g limit for 2-door vehicles. The pelvic acceleration has a 130g limit.

Appendix C—Test Data From NPRM

The NPRM presented the following data from tests of an ES-2re and a SID-IIsFRG dummy in oblique pole and FMVSS No. 214 MDB tests.

TABLE 1 TO APPENDIX C.—75-DEGREE POLE TEST RESULTS ES-2 DUMMY OR ES-2RE DUMMY

Test vehicle	Restraint*	HIC ₃₆	Rib-def. (mm)	Lower spine (g)	Abd.-force (N)	Pubic-force (N)
	Proposed limits	1,000	*** 35-44	82	***2,400-2,800	6,000
Test Results Using FMVSS No. 214 Seating Position						
1999 Volvo S80**	AC+Th	329	48.7	51.2	1,550	1,130
2000 Saab 9-5**	Comb	171	49.4	49.0	1,370	1,730
2004 Honda Accord**	AC+Th	446	30.7	51.7	1,437	2,463
2004 Toyota Camry**	AC+Th	452	43.4	52.5	1,165	1,849
Test Results Using FMVSS No. 201 Seating Position						
1999 Nissan Maxima	Comb	5,254	35.7	45.1	1,196	2,368
1999 Volvo S80	AC+Th	465	40.7	51.4	1,553	1,700
2000 Saab 9-5	Comb	243	49.9	58.3	1,382	2,673
2001 Saturn L200	AC	670	52.3	78.2	1,224	2,377
2002 Ford Explorer**	AC	629	43.0	98.4	2,674	2,317

*Comb. = combination head/chest SIAB; AC = air curtain; Thorax or Th=chest SIAB.

**Test was conducted with the ES-2re dummy.

***The agency stated that a particular value within this range would be selected.

TABLE 2 TO APPENDIX C.—75-DEGREE POLE TEST RESULTS [SID-IIsFRG dummy]

Test vehicle	Restraint *	HIC ₃₆	Lower spine (g)	Pelvis (N)
Proposed limits		1,000	82	5,100
2003 Toyota Camry (tested April 2003)	AC+Th (remotely fired at 11 ms)	512	70	4,580
2003 Toyota Camry (tested March 2003)	AC+Th (bags did not deploy)	8,706	78	5,725
2000 Saab 9-5	Comb	2,233	67	6,045
2002 Ford Explorer	AC (remotely fired at 13 ms)	4,595	101	7,141

* Comb.=head/chest SIAB; AC=air curtain; Th=chest SIAB

TABLE 3 TO APPENDIX C.—FMVSS NO. 214 MDB TEST RESULTS [ES-2re driver]

Test vehicle	Restraint HPS and/or SIAB	HIC ₃₆	Rib-def. (mm)	Lower spine (g)	Abd.-force (N)	Pubic-symph. (N)
Proposed limits		1,000	* 35-44	82	* 2,400-2,800	6,000
2001 Ford Focus	None	137	36	60	1,648	2,833
2002 Chevrolet Impala	None	69	46	49	1,225	1,789

* The agency stated that a particular value within this range would be selected.

TABLE 4 TO APPENDIX C.—FMVSS NO. 214 MDB TEST RESULTS
[ES—2re rear passenger]

Test vehicle	Restraint HPS and/or SIAB	HIC ₃₆	Rib-def. (mm)	Lower spine (g)	Abd.-force (N)	Pubic-symph. (N)
Proposed limits	1,000	35–44	82	*2,400–2,800	6,000
2001 Ford Focus	None	174	20	59	1,121	2,759
2002 Chevrolet Impala	None	187	12	58	4,409	2,784

*The agency stated that a particular value within this range would be selected.

TABLE 5 TO APPENDIX C.—FMVSS NO. 214 MDB TEST RESULTS
[SID—IIsFRG driver]

Test vehicle	Restraint HPS and/or SIAB	HIC ₃₆	Lower spine (g)	Pelvis (N)
Proposed limits	1,000	82	5,100
2001 Ford Focus	None	181	72	5,621
2002 Chevrolet Impala	None	76	52	2,753
2001 Buick Le Sabre	Thorax	130	67	4,672

TABLE 6 TO APPENDIX C.—FMVSS NO. 214 MDB TEST RESULTS
[SID—IIsFRG rear passenger]

Test vehicle	Restraint HPS and/or SIAB	HIC ₃₆	Lower spine (g)	Pelvis (N)
Proposed limits	1,000	82	5,100
2001 Ford Focus	None	526	65	3,997
2002 Chevrolet Impala	None	153	89	5,711
2001 Buick Le Sabre	None	221	77	4,041

List of Subjects

49 CFR Part 571

Imports, Incorporation by reference, Motor vehicle safety, Reporting and recordkeeping requirements, Tires.

49 CFR Part 585

Motor vehicle safety, Reporting and recordkeeping requirements.

■ In consideration of the foregoing, NHTSA amends 49 CFR Chapter V as set forth below.

PART 571—FEDERAL MOTOR VEHICLE SAFETY STANDARDS

■ 1. The authority citation for part 571 continues to read as follows:

Authority: 49 U.S.C. 322, 30111, 30115, 30117 and 30166; delegation of authority at 49 CFR 1.50.

■ 2. Section 571.201 is amended by revising S6.2(b)(3), adding S6.2(b)(4), and revising S8.18, S8.19 and S8.28, to read as follows:

§ 571.201 Standard No. 201; Occupant protection in interior impact.

* * * * *

S6.2 *Vehicles manufactured on or after September 1, 2002 and vehicles built in two or more stages manufactured after September 1, 2006.*
* * *

(b) * * *

(3) Except as provided in S6.2(b)(4), each vehicle shall, when equipped with a dummy test device specified in 49 CFR part 572, subpart M, and tested as specified in S8.16 through S8.28, comply with the requirements specified in S7 when crashed into a fixed, rigid pole of 254 mm in diameter, at any velocity between 24 kilometers per hour (15 mph) and 29 kilometers per hour (18 mph).

(4) Vehicles certified as complying with the vehicle-to-pole requirements of S9 of 49 CFR 571.214, *Side Impact Protection*, need not comply with the pole test requirements specified in S6.2(b)(3) of this section.

* * * * *

S8.18 *Adjustable seats—vehicle to pole test.* Initially, adjustable seats shall be adjusted as specified in S8.3.1 of Standard 214 (49 CFR 571.214).

S8.19 *Adjustable seat back placement—vehicle to pole test.* Initially, position adjustable seat backs in the manner specified in S8.3.1 of Standard 214 (49 CFR 571.214).

* * * * *

S8.28 *Positioning procedure for the Part 572 Subpart M test dummy—vehicle to pole test.* The part 572, subpart M, test dummy is initially positioned in the front outboard seating

position on the struck side of the vehicle in accordance with the provisions of S12.1 of Standard 214 (49 CFR 571.214), and the vehicle seat is positioned as specified in S8.3.1 of that standard. The position of the dummy is then measured as follows. Locate the horizontal plane passing through the dummy head center of gravity. Identify the rearmost point on the dummy head in that plane. Construct a line in the plane that contains the rearward point of the front door daylight opening and is perpendicular to the longitudinal vehicle centerline. Measure the longitudinal distance between the rearmost point on the dummy head and this line. If this distance is less than 50 mm (2 inches) or the point is not forward of the line, then the seat and/or dummy positions is adjusted as follows. First, the seat back angle is adjusted, a maximum of 5 degrees, until a 50 mm (2 inches) distance is achieved. If this is not sufficient to produce the 50 mm (2 inches) distance, the seat is moved forward until the 50 mm (2 inches) distance is achieved or until the knees of the dummy contact the dashboard or knee bolster, whichever comes first. If the required distance cannot be achieved through movement of the seat, the seat back angle is adjusted even further forward until the

50 mm (2 inches) distance is obtained or until the seat back is in its fully upright locking position.

* * * * *

■ 3. Section 571.214 is revised to read as follows:

§ 571.214 Standard No. 214; Side impact protection.

S1 Scope and purpose.

(a) *Scope.* This standard specifies performance requirements for protection of occupants in side impacts.

(b) *Purpose.* The purpose of this standard is to reduce the risk of serious and fatal injury to occupants of passenger cars, multipurpose passenger vehicles, trucks and buses in side impacts by specifying strength requirements for side doors, limiting the forces, deflections and accelerations measured on anthropomorphic dummies in test crashes, and by other means.

S2 Applicability. This standard applies to passenger cars, and to multipurpose passenger vehicles, trucks and buses with a gross vehicle weight rating (GVWR) of 4,536 kilograms (kg) (10,000 pounds (lb)) or less, except for walk-in vans, or otherwise specified.

S3 Definitions.

Contoured means, with respect to a door, that the lower portion of its front or rear edge is curved upward, typically to conform to a wheel well.

Double side doors means a pair of hinged doors with the lock and latch mechanisms located where the door lips overlap.

Limited line manufacturer means a manufacturer that sells three or fewer carlines, as that term is defined in 49 CFR 585.4, in the United States during a production year.

Lowered floor means the replacement floor on a motor vehicle whose original floor has been removed, in part or in total, and replaced by a floor that is lower than the original floor.

Modified roof means the replacement roof on a motor vehicle whose original roof has been removed, in part or in total.

Raised roof is used as defined in paragraph S4 of 49 CFR 571.216.

Walk-in van means a special cargo/mail delivery vehicle that has only one designated seating position. That designated seating position must be forward facing and for use only by the driver. The vehicle usually has a thin and light sliding (or folding) side door for easy operation and a high roof clearance that a person of medium stature can enter the passenger compartment area in an up-right position.

S4 Requirements. Subject to the exceptions of S5—

(a) *Passenger cars.* Passenger cars must meet the requirements set forth in S6 (door crush resistance), S7 (moving deformable barrier test), and S9 (vehicle-to-pole test), subject to the phased-in application of S7 and S9.

(b) *Multipurpose passenger vehicles, trucks and buses with a GVWR of 2,722 kg or less (6,000 lb or less).* Multipurpose passenger vehicles, trucks and buses with a GVWR of 2,722 kg or less (6,000 lb or less) must meet the requirements set forth in S6 (door crush resistance), S7 (moving deformable barrier test), and S9 (vehicle-to-pole test), subject to the phased-in application of S7 and S9.

(c) *Multipurpose passenger vehicles, trucks and buses with a GVWR greater than 2,722 kg (6,000 lb).* Multipurpose passenger vehicles, trucks and buses with a GVWR greater than 2,722 kg (6,000 lb) must meet the requirements set forth in S6 (door crush resistance) and S9 (vehicle-to-pole test), subject to the phased-in application of S9.

S5 General exclusions.

(a) *Exclusions from S6 (door crush resistance).* A vehicle need not meet the requirements of S6 (door crush resistance) for—

(1) Any side door located so that no point on a ten-inch horizontal longitudinal line passing through and bisected by the H—point of a manikin placed in any seat, with the seat adjusted to any position and the seat back adjusted as specified in S8.4, falls within the transverse, horizontal projection of the door's opening.

(2) Any side door located so that no point on a ten-inch horizontal longitudinal line passing through and bisected by the H—point of a manikin placed in any seat recommended by the manufacturer for installation in a location for which seat anchorage hardware is provided, with the seat adjusted to any position and the seat back adjusted as specified in S8.3, falls within the transverse, horizontal projection of the door's opening.

(3) Any side door located so that a portion of a seat, with the seat adjusted to any position and the seat back adjusted as specified in S8.3, falls within the transverse, horizontal projection of the door's opening, but a longitudinal vertical plane tangent to the outboard side of the seat cushion is more than 254 mm (10 inches) from the innermost point on the inside surface of the door at a height between the H—point and shoulder reference point (as shown in Figure 1 of Federal Motor Vehicle Safety Standard No. 210 (49 CFR 571.210)) and longitudinally

between the front edge of the cushion with the seat adjusted to its forwardmost position and the rear edge of the cushion with the seat adjusted to its rearmost position.

(4) Any side door that is designed to be easily attached to or removed (e.g., using simple hand tools such as pliers and/or a screwdriver) from a motor vehicle manufactured for operation without doors.

(b) *Exclusions from S7 (moving deformable barrier test).* The following vehicles are excluded from S7 (moving deformable barrier test):

(1) Motor homes, ambulances and other emergency rescue/medical vehicles (including vehicles with fire-fighting equipment), vehicles equipped with wheelchair lifts, and vehicles which have no doors or exclusively have doors that are designed to be easily attached or removed so the vehicle can be operated without doors.

(2) Passenger cars with a wheelbase greater than 130 inches need not meet the requirements of S7 as applied to the rear seat.

(3) Passenger cars, multipurpose passenger vehicles, trucks and buses need not meet the requirements of S7 (moving deformable barrier test) as applied to the rear seat for side-facing rear seats and for rear seating areas that are so small that a Part 572 Subpart V dummy representing a 5th percentile adult female cannot be accommodated according to the positioning procedure specified in S12.3.4 of this standard.

(4) Multipurpose passenger vehicles, trucks and buses with a GVWR of more than 2,722 kg (6,000 lb) need not meet the requirements of S7 (moving deformable barrier test).

(c) *Exclusions from S9 (vehicle-to-pole test).* The following vehicles are excluded from S9 (vehicle-to-pole test) (wholly or in limited part, as set forth below):

(1) Motor homes;

(2) Ambulances and other emergency rescue/medical vehicles (including vehicles with fire-fighting equipment) except police cars;

(3) Vehicles with a lowered floor or raised or modified roof and vehicles that have had the original roof rails removed and not replaced;

(4) Vehicles in which the seat for the driver or right front passenger has been removed and wheelchair restraints installed in place of the seat are excluded from meeting the vehicle-to-pole test at that position; and

(5) Vehicles that have no doors, or exclusively have doors that are designed to be easily attached or removed so that the vehicle can be operated without doors.

S6 Door Crush Resistance Requirements. Except as provided in section S5, each vehicle shall be able to meet the requirements of either, at the manufacturer's option, S6.1 or S6.2, when any of its side doors that can be used for occupant egress is tested according to procedures described in S6.3 of this standard (49 CFR 571.214).

S6.1 With any seats that may affect load upon or deflection of the side of the vehicle removed from the vehicle, each vehicle must be able to meet the requirements of S6.1.1 through S6.1.3.

S6.1.1 Initial crush resistance. The initial crush resistance shall not be less than 10,000 N (2,250 lb).

S6.1.2 Intermediate crush resistance. The intermediate crush resistance shall not be less than 1,557 N (3,500 lb).

S6.1.3 Peak crush resistance. The peak crush resistance shall not be less than two times the curb weight of the vehicle or 3,114 N (7,000 lb), whichever is less.

S6.2 With seats installed in the vehicle, and located in any horizontal or vertical position to which they can be adjusted and at any seat back angle to which they can be adjusted, each vehicle must be able to meet the requirements of S6.2.1 through S6.2.3.

S6.2.1 Initial crush resistance. The initial crush resistance shall not be less than 10,000 N (2,250 lb).

S6.2.2 Intermediate crush resistance. The intermediate crush resistance shall not be less than 1,946 N (4,375 lb).

S6.2.3 Peak crush resistance. The peak crush resistance shall not be less than three and one half times the curb weight of the vehicle or 5,338 N (12,000 lb), whichever is less.

S6.3 *Test procedures for door crush resistance.* The following procedures apply to determining compliance with S6.1 and S6.2 of S6, *Door crush resistance requirements.*

(a) Place side windows in their uppermost position and all doors in locked position. Place the sill of the side of the vehicle opposite to the side being tested against a rigid unyielding vertical surface. Fix the vehicle rigidly in position by means of tiedown attachments located at or forward of the front wheel centerline and at or rearward of the rear wheel centerline.

(b) Prepare a loading device consisting of a rigid steel cylinder or semi-cylinder 305 mm (12 inches) in diameter with an edge radius of 13 mm ($\frac{1}{2}$ inch). The length of the loading device shall be such that—

(1) For doors with windows, the top surface of the loading device is at least

13 mm ($\frac{1}{2}$ inch) above the bottom edge of the door window opening but not of a length that will cause contact with any structure above the bottom edge of the door window opening during the test.

(2) For doors without windows, the top surface of the loading device is at the same height above the ground as when the loading device is positioned in accordance with paragraph (b)(1) of this section for purposes of testing a front door with windows on the same vehicle.

(c) Locate the loading device as shown in Figure 1 (side view) of this section so that—

(1) Its longitudinal axis is vertical.

(2) Except as provided in paragraphs (c)(2)(i) and (ii) of this section, its longitudinal axis is laterally opposite the midpoint of a horizontal line drawn across the outer surface of the door 127 mm (5 inches) above the lowest point of the door, exclusive of any decorative or protective molding that is not permanently affixed to the door panel.

(i) For contoured doors on trucks, buses, and multipurpose passenger vehicles with a GVWR of 4,536 kg (10,000 lb) or less, if the length of the horizontal line specified in this paragraph (c)(2) is not equal to or greater than 559 mm (22 inches), the line is moved vertically up the side of the door to the point at which the line is 559 mm (22 inches) long. The longitudinal axis of the loading device is then located laterally opposite the midpoint of that line.

(ii) For double side doors on trucks, buses, and multipurpose passenger vehicles with a GVWR of 4,536 kg (10,000 lb) or less, its longitudinal axis is laterally opposite the midpoint of a horizontal line drawn across the outer surface of the double door span, 127 mm (5 inches) above the lowest point on the doors, exclusive of any decorative or protective molding that is not permanently affixed to the door panel.

(3) Except as provided in paragraphs (c)(3)(i) and (ii) of this section, its bottom surface is in the same horizontal plane as the horizontal line drawn across the outer surface of the door 127 mm (5 inches) above the lowest point of the door, exclusive of any decorative or protective molding that is not permanently affixed to the door panel.

(i) For contoured doors on trucks, buses, and multipurpose passenger vehicles with a GVWR of 4,536 kg (10,000 lb) or less, its bottom surface is in the lowest horizontal plane such that every point on the lateral projection of

the bottom surface of the device on the door is at least 127 mm (5 inches), horizontally and vertically, from any edge of the door panel, exclusive of any decorative or protective molding that is not permanently affixed to the door panel.

(ii) For double side doors, its bottom surface is in the same horizontal plane as a horizontal line drawn across the outer surface of the double door span, 127 mm (5 inches) above the lowest point of the doors, exclusive of any decorative or protective molding that is not permanently affixed to the door panel.

(d) Using the loading device, apply a load to the outer surface of the door in an inboard direction normal to a vertical plane along the vehicle's longitudinal centerline. Apply the load continuously such that the loading device travel rate does not exceed 12.7 mm (0.5 inch) per second until the loading device travels 457 mm (18 inches). Guide the loading device to prevent it from being rotated or displaced from its direction of travel. The test is completed within 120 seconds.

(e) Record applied load versus displacement of the loading device, either continuously or in increments of not more than 25.4 mm (1 inch) or 91 kg (200 pounds) for the entire crush distance of 457 mm (18 inches).

(f) Determine the initial crush resistance, intermediate crush resistance, and peak crush resistance as follows:

(1) From the results recorded in paragraph (e) of this section, plot a curve of load versus displacement and obtain the integral of the applied load with respect to the crush distances specified in paragraphs (f)(2) and (3) of this section. These quantities, expressed in mm-kN (inch-pounds) and divided by the specified crush distances, represent the average forces in kN (pounds) required to deflect the door those distances.

(2) The initial crush resistance is the average force required to deform the door over the initial 152 mm (6 inches) of crush.

(3) The intermediate crush resistance is the average force required to deform the door over the initial 305 mm (12 inches) of crush.

(4) The peak crush resistance is the largest force recorded over the entire 457 mm (18-inch) crush distance.

BILLING CODE 4910-59-P

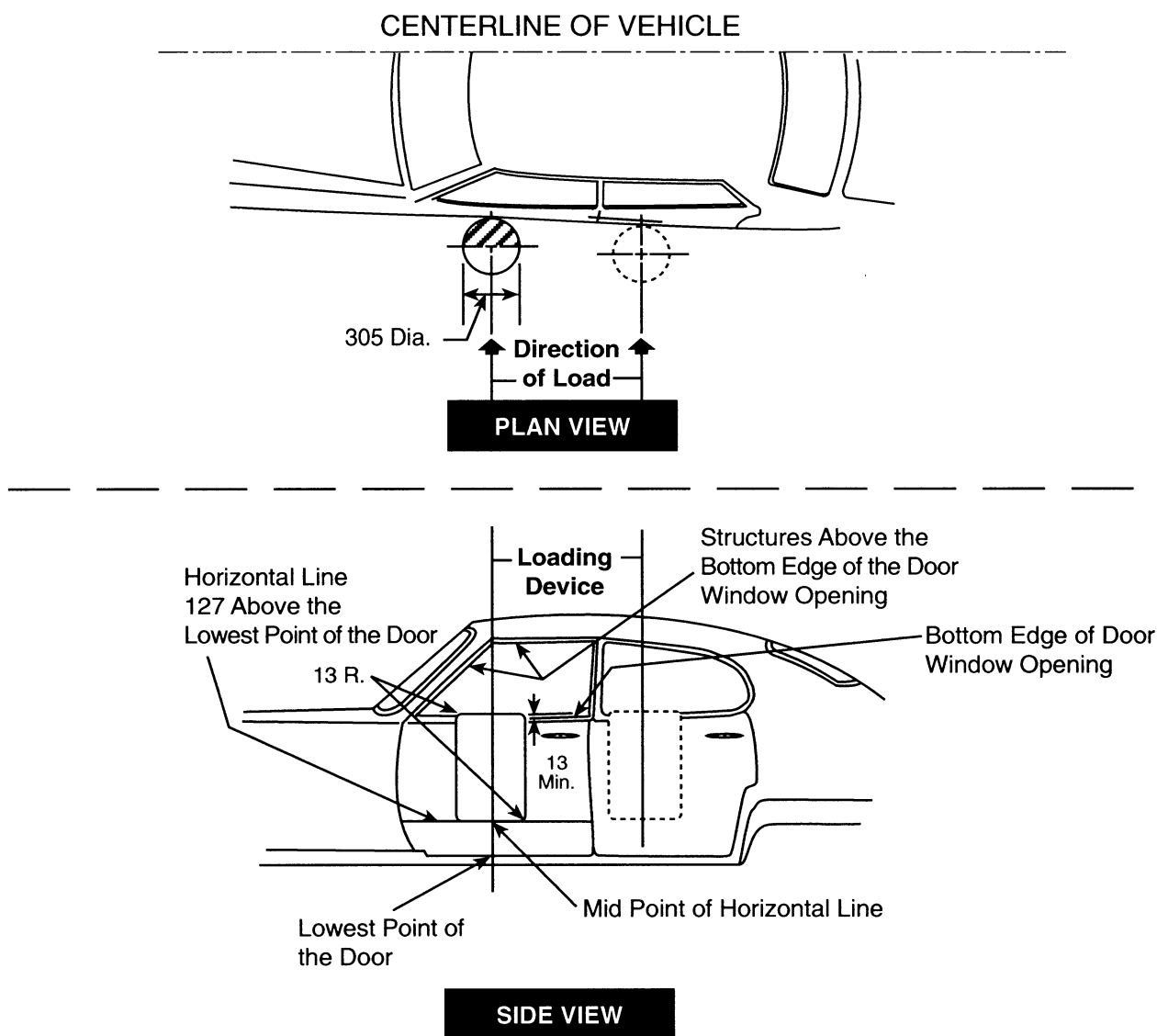

Figure 1—LOADING DEVICE LOCATION AND APPLICATION TO THE DOOR
All dimensions in millimeters (mm)

S7 *Moving Deformable Barrier (MDB) Requirements.* Except as provided in section S5, when tested under the conditions of S8 each vehicle shall meet S7.3 and the following requirements in a 53 ± 1.0 km/h (33.5 mph) impact in which the vehicle is struck on either side by a moving deformable barrier.

S7.1 *MDB test with SID.* For vehicles manufactured before September 1, 2009, the following requirements must be met. The following requirements also apply to vehicles manufactured on or after September 1, 2009 that are not part of the percentage of a manufacturer's production meeting the MDB test with advanced test dummies (S7.2 of this section) or are otherwise excluded from

the phase-in requirements of S7.2. (Vehicles manufactured before September 1, 2009 may meet S7.2, at the manufacturer's option.)

S7.1.1 The test dummy specified in 49 CFR Part 572 Subpart F (SID) is placed in the front and rear outboard seating positions on the struck side of the vehicle, as specified in S11 and S12 of this standard (49 CFR 571.214).

S7.1.2 When using the Part 572 Subpart F dummy (SID), the following performance requirements must be met.

(a) *Thorax.* The Thoracic Trauma Index (TTI(d)) shall not exceed:

(1) 85 g for a passenger car with four side doors, and for any multipurpose passenger vehicle, truck, or bus; and,

(2) 90 g for a passenger car with two side doors, when calculated in accordance with the following formula:
 $TI(d) = \frac{1}{2}(G_R + G_{LS})$

Where the term " G_R " is the greater of the peak accelerations of either the upper or lower rib, expressed in g's and the term " G_{LS} " is the lower spine (T12) peak acceleration, expressed in g's. The peak acceleration values are obtained in accordance with the procedure specified in S11.5.

(b) *Pelvis.* The peak lateral acceleration of the pelvis, as measured in accordance with S11.5, shall not exceed 130 g's.

S7.2 *MDB test with advanced test dummies.*

S7.2.1 Vehicles manufactured on or after September 1, 2009 to August 31, 2012.

(a) Except as provided in S7.2.4 of this section, for vehicles manufactured on or after September 1, 2009 to August 31, 2012, a percentage of each manufacturer's production, as specified in S13.1.1, S13.1.2, and S13.1.3, shall meet the requirements of S7.2.5 and S7.2.6 when tested with the test dummy specified in those sections. Vehicles manufactured before September 1, 2012 may be certified as meeting the requirements of S7.2.5 and S7.2.6.

(b) For vehicles manufactured on or after September 1, 2009 that are not part of the percentage of a manufacturer's production meeting S7.2.1 of this section, the requirements of S7.1 of this section must be met.

(c) Place the Subpart U ES-2re 50th percentile male dummy in the front seat and the Subpart V SID-IIs 5th percentile female test dummy in the rear seat. The test dummies are placed and positioned in the front and rear outboard seating positions on the struck side of the vehicle, as specified in S11 and S12 of this standard (49 CFR 571.214).

S7.2.2 Vehicles manufactured on or after September 1, 2012.

(a) Subject to S7.2.4 of this section, each vehicle manufactured on or after September 1, 2012 must meet the requirements of S7.2.5 and S7.2.6, when tested with the test dummy specified in those sections.

(b) Place the Subpart U ES-2re 50th percentile male dummy in the front seat and the Subpart V SID-IIs 5th percentile female test dummy in the rear seat. The test dummies are placed and positioned in the front and rear outboard seating positions on the struck side of the vehicle, as specified in S11 and S12 of this standard (49 CFR 571.214).

S7.2.3 [Reserved]

S7.2.4 Exceptions from the MDB phase-in; special allowances.

(a)(1) Vehicles that are manufactured on or after September 1, 2012 by an original vehicle manufacturer that produces or assembles fewer than 5,000 vehicles annually for sale in the United States are not subject to S7.2.1 of this section (but are subject to S7.2.2);

(2) Vehicles that are manufactured on or after September 1, 2012 by a limited line manufacturer are not subject to S7.2.1 of this section (but are subject to S7.2.2).

(b) Vehicles that are altered (within the meaning of 49 CFR 567.7) before September 1, 2013 after having been previously certified in accordance with part 567 of this chapter, and vehicles manufactured in two or more stages before September 1, 2013, are not

subject to S7.2.1. Vehicles that are altered on or after September 1, 2013, and vehicles that are manufactured in two or more stages on or after September 1, 2013, must meet the requirements of S7.2.5 and S7.2.6, when tested with the test dummy specified in those sections. Place the Subpart U ES-2re 50th percentile male dummy in the front seat and the Subpart V SID-IIs 5th percentile female test dummy in the rear seat. The test dummies are placed and positioned in the front and rear outboard seating positions on the struck side of the vehicle, as specified in S11 and S12 of this standard (49 CFR 571.214).

S7.2.5 Dynamic performance requirements using the Part 572 Subpart U dummy (ES-2re 50th percentile male) dummy. Use the 49 CFR Part 572 Subpart U ES-2re dummy specified in S11 with measurements in accordance with S11.5. The following criteria shall be met:

(a) The HIC shall not exceed 1000 when calculated in accordance with the following formula:

$$\text{HIC} = \left[\frac{1}{(t_2 - t_1)} \int_{t_1}^{t_2} a dt \right]^{2.5} (t_2 - t_1)$$

Where the term *a* is the resultant head acceleration at the center of gravity of the dummy head expressed as a multiple of *g* (the acceleration of gravity), and *t*₁ and *t*₂ are any two points in time during the impact which are separated by not more than a 36 millisecond time interval and where *t*₁ is less than *t*₂.

(b) Thorax. The deflection of any of the upper, middle, and lower ribs, shall not exceed 44 mm (1.65 inches).

(c) Force measurements.

(1) The sum of the front, middle and rear abdominal forces, shall not exceed 2,500 N (562 lb).

(2) The pubic symphysis force shall not exceed 6,000 N (1,350 pounds).

S7.2.6 Dynamic performance requirements using the Part 572 Subpart V SID-IIs (5th percentile female) dummy. Use the 49 CFR Part 572 Subpart V SID-IIs 5th percentile female dummy specified in S11 with measurements in accordance with S11.5. The following criteria shall be met:

(a) The HIC shall not exceed 1000 when calculated in accordance with the following formula:

$$\text{HIC} = \left[\frac{1}{(t_2 - t_1)} \int_{t_1}^{t_2} a dt \right]^{2.5} (t_2 - t_1)$$

Where the term *a* is the resultant head acceleration expressed as a multiple of

g (the acceleration of gravity), and *t*₁ and *t*₂ are any two points in time during the impact which are separated by not more than a 36 millisecond time interval.

(b) The resultant lower spine acceleration shall not exceed 82 *g*.

(c) The sum of the acetabular and iliac pelvic forces shall not exceed 5,525 N.

S7.3 Door opening.

(a) Any side door that is struck by the moving deformable barrier shall not separate totally from the vehicle.

(b) Any door (including a rear hatchback or tailgate) that is not struck by the moving deformable barrier shall meet the following requirements:

(1) The door shall not disengage from the latched position;

(2) The latch shall not separate from the striker, and the hinge components shall not separate from each other or from their attachment to the vehicle.

(3) Neither the latch nor the hinge systems of the door shall pull out of their anchorages.

S8 Test conditions for determining compliance with moving deformable barrier requirements. General test conditions for determining compliance with the moving deformable barrier test are specified below. Additional specifications may also be found in S12 of this standard (49 CFR 571.214).

S8.1 Test weight. Each vehicle is loaded to its unloaded vehicle weight, plus 136 kg (300 pounds) or its rated cargo and luggage capacity (whichever is less), secured in the luggage or load-carrying area, plus the weight of the necessary anthropomorphic test dummies. Any added test equipment is located away from impact areas in secure places in the vehicle. The vehicle's fuel system is filled in accordance with the following procedure. With the test vehicle on a level surface, pump the fuel from the vehicle's fuel tank and then operate the engine until it stops. Then, add Stoddard solvent to the test vehicle's fuel tank in an amount that is equal to not less than 92 percent and not more than 94 percent of the fuel tank's usable capacity stated by the vehicle's manufacturer. In addition, add the amount of Stoddard solvent needed to fill the entire fuel system from the fuel tank through the engine's induction system.

S8.2 Vehicle test attitude. Determine the distance between a level surface and a standard reference point on the test vehicle's body, directly above each wheel opening, when the vehicle is in its "as delivered" condition. The "as delivered" condition is the vehicle as received at the test site, filled to 100

percent of all fluid capacities and with all tires inflated to the manufacturer's specifications listed on the vehicle's tire placard. Determine the distance between the same level surface and the same standard reference points in the vehicle's "fully loaded condition." The "fully loaded condition" is the test vehicle loaded in accordance with S8.1 of this standard (49 CFR 571.214). The load placed in the cargo area is centered over the longitudinal centerline of the vehicle. The pretest vehicle attitude is equal to either the as delivered or fully loaded attitude or between the as delivered attitude and the fully loaded attitude, ± 10 mm.

S8.3 Adjustable seats.

S8.3.1 50th Percentile Male Dummy In Front Seats.

S8.3.1.1 *Lumbar support adjustment.* Position adjustable lumbar supports so that the lumbar support is in its lowest, retracted or deflated adjustment position.

S8.3.1.2 *Other seat adjustments.* Position any adjustable parts of the seat that provide additional support so that they are in the lowest or non-deployed adjustment position. Position any adjustable head restraint in the highest and most forward position. Place adjustable seat backs in the manufacturer's nominal design riding position in the manner specified by the manufacturer. If the position is not specified, set the seat back at the first detent rearward of 25° from the vertical.

S8.3.1.3 *Seat position adjustment.* If the passenger seat does not adjust independently of the driver seat, the driver seat shall control the final position of the passenger seat.

S8.3.1.3.1 Using only the controls that primarily move the seat and seat cushion independent of the seat back in the fore and aft directions, move the seat cushion reference point (SCRCP) to the rearmost position. Using any part of any control, other than those just used, determine the full range of angles of the seat cushion reference line and set the seat cushion reference line to the middle of the range. Using any part of any control other than those that primarily move the seat or seat cushion fore and aft, while maintaining the seat cushion reference line angle, place the SCRCP to its lowest position.

S8.3.1.3.2 Using only the control that primarily moves the seat fore and aft, move the seat cushion reference point to the mid travel position. If an adjustment position does not exist midway between the forwardmost and rearmost positions, the closest adjustment position to the rear of the midpoint is used.

S8.3.1.3.3 If the seat or seat cushion height is adjustable, other than by the controls that primarily move the seat or seat cushion fore and aft, set the height of the seat cushion reference point to the minimum height, with the seat cushion reference line angle set as closely as possible to the angle determined in S8.3.1.3.1. Mark location of the seat for future reference.

S8.3.2 [Reserved]

S8.3.3 5th Percentile Female Dummy in Second Row Seat.

S8.3.3.1 *Lumbar support adjustment.* Position adjustable lumbar supports so that the lumbar support is in its lowest, retracted or deflated adjustment position.

S8.3.3.2 *Other seat adjustments.* Position any adjustable parts of the seat that provide additional support so that they are in the lowest or non-deployed adjustment position. Position any adjustable head restraint in the lowest and most forward position. Place adjustable seat backs in the manufacturer's nominal design riding position in the manner specified by the manufacturer. If the position is not specified, set the seat back at the first detent rearward of 25° from the vertical.

S8.3.3.3 *Seat position adjustment.* Using only the controls that primarily move the seat and seat cushion independent of the seat back in the fore and aft directions, move the seat cushion reference point (SCRCP) to the rearmost position. Using any part of any control, other than those just used, determine the full range of angles of the seat cushion reference line and set the seat cushion reference line to the middle of the range. Using any part of any control other than those that primarily move the seat or seat cushion fore and aft, while maintaining the seat cushion reference line angle, place the SCRCP to its lowest position. Mark location of the seat for future reference.

S8.4 *Adjustable steering wheel.* Adjustable steering controls are adjusted so that the steering wheel hub is at the geometric center of the locus it describes when it is moved through its full range of driving positions. If there is no setting detent in the mid-position, lower the steering wheel to the detent just below the mid-position. If the steering column is telescoping, place the steering column in the mid-position. If there is no mid-position, move the steering wheel rearward one position from the mid-position.

S8.5 *Windows and sunroofs.* Movable vehicle windows and vents are placed in the fully closed position on the struck side of the vehicle. Any sunroof shall be placed in the fully closed position.

S8.6 *Convertible tops.* Convertibles and open-body type vehicles have the top, if any, in place in the closed passenger compartment configuration.

S8.7 *Doors.* Doors, including any rear hatchback or tailgate, are fully closed and latched but not locked.

S8.8 *Transmission and brake engagement.* For a vehicle equipped with a manual transmission, the transmission is placed in second gear. For a vehicle equipped with an automatic transmission, the transmission is placed in neutral. For all vehicles, the parking brake is engaged.

S8.9 *Moving deformable barrier.* The moving deformable barrier conforms to the dimensions shown in Figure 2 and specified in 49 CFR Part 587.

S8.10 *Impact configuration.* The test vehicle (vehicle A in Figure 3) is stationary. The line of forward motion of the moving deformable barrier (vehicle B in Figure 3) forms an angle of 63 degrees with the centerline of the test vehicle. The longitudinal centerline of the moving deformable barrier is perpendicular to the longitudinal centerline of the test vehicle when the barrier strikes the test vehicle. In a test in which the test vehicle is to be struck on its left (right) side: All wheels of the moving deformable barrier are positioned at an angle of 27 ± 1 degrees to the right (left) of the centerline of the moving deformable barrier; and the left (right) forward edge of the moving deformable barrier is aligned so that a longitudinal plane tangent to that side passes through the impact reference line within a tolerance of ± 51 mm (2 inches) when the barrier strikes the test vehicle.

S8.11 *Impact reference line.* Place a vertical reference line at the location described below on the side of the vehicle that will be struck by the moving deformable barrier.

S8.11.1 *Passenger cars.*
(a) For vehicles with a wheelbase of 2,896 mm (114 inches) or less, 940 mm (37 inches) forward of the center of the vehicle's wheelbase.

(b) For vehicles with a wheelbase greater than 2,896 mm (114 inches), 508 mm (20 inches) rearward of the centerline of the vehicle's front axle.

S8.11.2 *Multipurpose passenger vehicles, trucks and buses.*

(a) For vehicles with a wheelbase of 2,489 mm (98 inches) or less, 305 mm (12 inches) rearward of the centerline of the vehicle's front axle, except as otherwise specified in paragraph (d) of this section.

(b) For vehicles with a wheelbase of greater than 2,489 mm (98 inches) but not greater than 2,896 mm (114 inches), 940 mm (37 inches) forward of the center of the vehicle's wheelbase, except

as otherwise specified in paragraph (d) of this section.

(c) For vehicles with a wheelbase greater than 2,896 mm (114 inches), 508 mm (20 inches) rearward of the centerline of the vehicle's front axle, except as otherwise specified in paragraph (d) of this section.

(d) At the manufacturer's option, for different wheelbase versions of the same model vehicle, the impact reference line may be located by the following:

(1) Select the shortest wheelbase vehicle of the different wheelbase versions of the same model and locate on it the impact reference line at the

location described in (a), (b) or (c) of this section, as appropriate;

(2) Measure the distance between the seating reference point (SgRP) and the impact reference line;

(3) Maintain the same distance between the SgRP and the impact reference line for the version being tested as that between the SgRP and the impact reference line for the shortest wheelbase version of the model.

(e) For the compliance test, the impact reference line will be located using the procedure used by the manufacturer as the basis for its certification of compliance with the requirements of

this standard. If the manufacturer did not use any of the procedures in this section, or does not specify a procedure when asked by the agency, the agency may locate the impact reference line using either procedure.

S8.12 *Anthropomorphic test dummies*. The anthropomorphic test dummies used to evaluate a vehicle's performance in the moving deformable barrier test conform to the requirements of S11 and are positioned as described in S12 of this standard (49 CFR 571.214).

BILLING CODE 4910-59-P

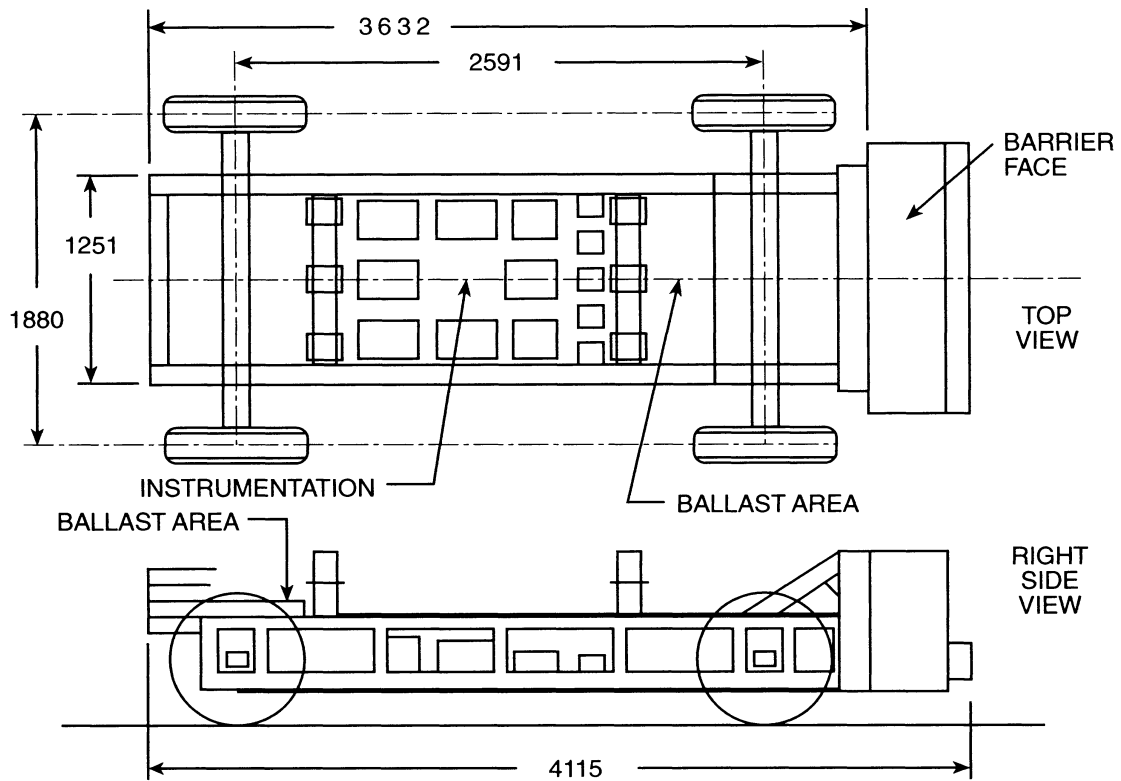

NHTSA VEHICLE SIMULATOR
All dimensions in millimeters (mm)

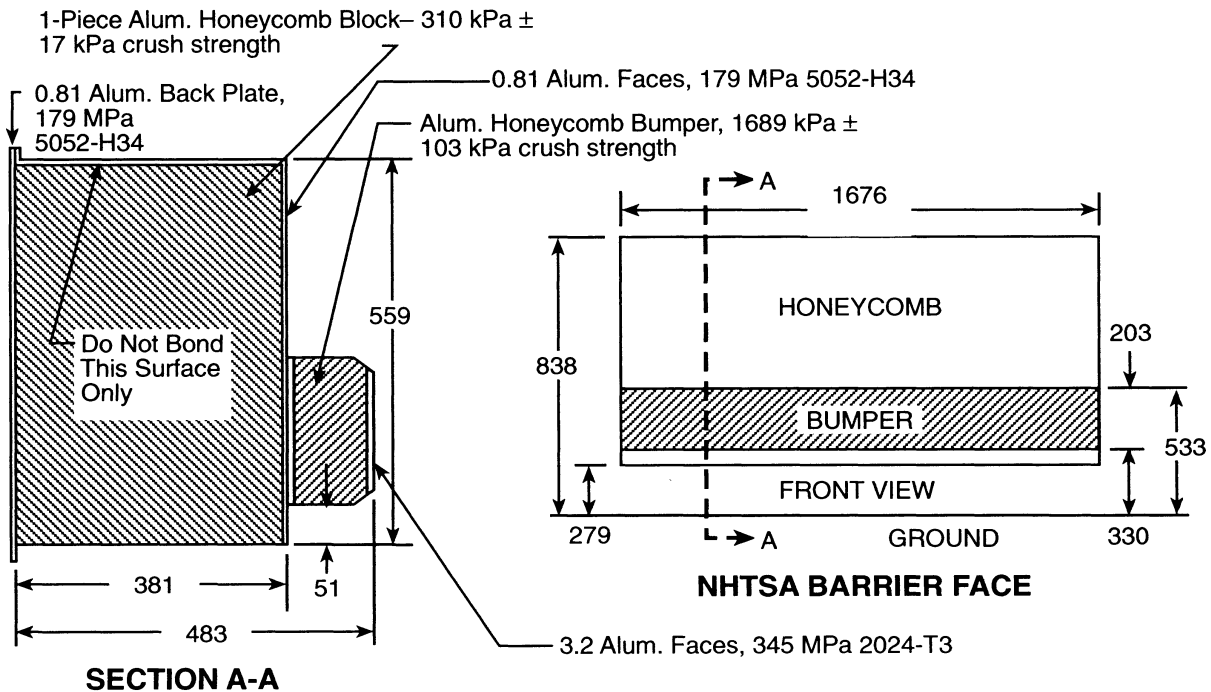

Figure 2—NHTSA SIDE IMPACTOR – MOVING DEFORMABLE BARRIER
All dimensions in millimeters (mm)

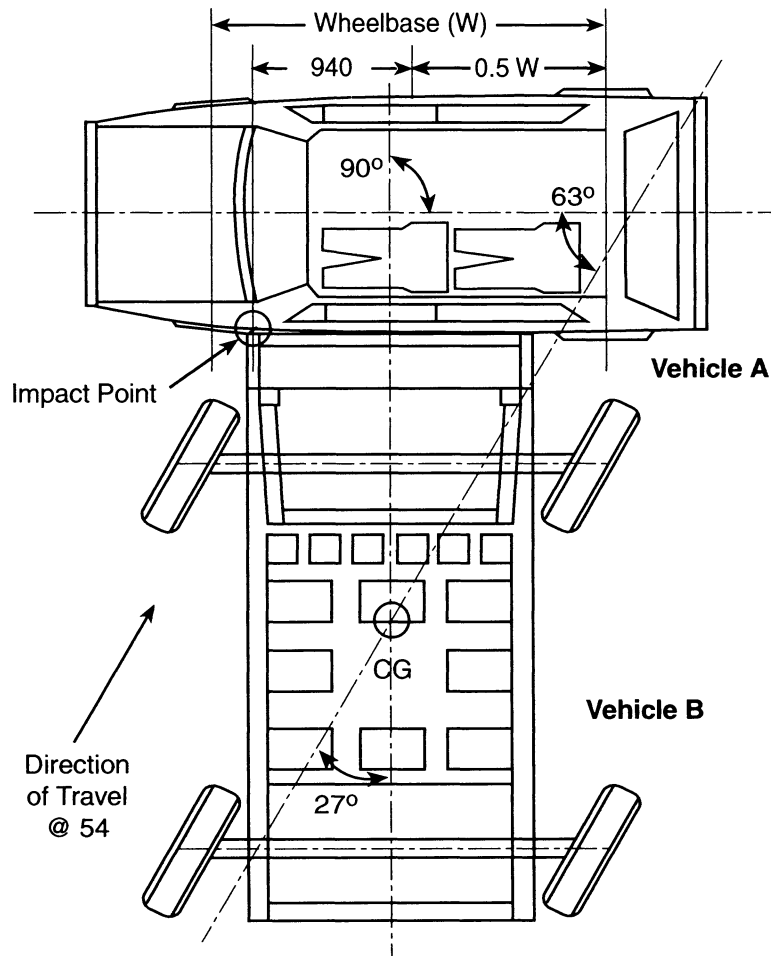

Figure 3—TEST CONFIGURATION
All dimensions in millimeters (mm)
velocity in km/h

BILLING CODE 4910-59-C

S9 Vehicle-to-Pole Requirements.

S9.1 Except as provided in S5, when tested under the conditions of S10:

S9.1.1 Except as provided in S9.1.3 of this section, for vehicles manufactured on or after September 1, 2009 to August 31, 2012, a percentage of each manufacturer's production, as specified in S13.1.1, S13.1.2, and S13.1.3, shall meet the requirements of S9.2.1, S9.2.2, and S9.2.3 when tested under the conditions of S10 into a fixed, rigid pole of 254 mm (10 inches) in diameter, at any velocity up to and including 32 km/h (20 mph). Vehicles manufactured before September 1, 2012 that are not subject to the phase-in may be certified as meeting the requirements specified in this section.

S9.1.2 Except as provided in S9.1.3 of this section, each vehicle manufactured on or after September 1, 2012, must meet the requirements of

S9.2.1, S9.2.2 and S9.2.3, when tested under the conditions specified in S10 into a fixed, rigid pole of 254 mm (10 inches) in diameter, at any speed up to and including 32 km/h (20 mph).

S9.1.3 Exceptions from the phase-in; special allowances.

(a)(1) Vehicles that are manufactured by an original vehicle manufacturer that produces or assembles fewer than 5,000 vehicles annually for sale in the United States are not subject to S9.1.1 of this section (but are subject to S9.1.2);

(2) Vehicles that are manufactured by a limited line manufacturer are not subject to S9.1.1 of this section (but are subject to S9.1.2).

(b) Vehicles that are altered (within the meaning of 49 CFR 567.7) before September 1, 2013 after having been previously certified in accordance with part 567 of this chapter, and vehicles manufactured in two or more stages before September 1, 2013, are not

subject to S9.1.1. Vehicles that are altered on or after September 1, 2013, and vehicles that are manufactured in two or more stages on or after September 1, 2013, must meet the requirements of S9, when tested under the conditions specified in S10 into a fixed, rigid pole of 254 mm (10 inches) in diameter, at any speed up to and including 32 km/h (20 mph).

(c) Vehicles with a gross vehicle weight rating greater than 3,855 kg (8,500 lb) manufactured before September 1, 2013 are not subject to S9.1.1 or S9.1.2 of this section. These vehicles may be voluntarily certified to meet the pole test requirements prior to September 1, 2013. Vehicles with a gross vehicle weight rating greater than 3,855 kg (8,500 lb) manufactured on or after September 1, 2013 must meet the requirements of S9.2.1, S9.2.2 and S9.2.3, when tested under the conditions specified in S10 into a fixed,

rigid pole of 254 mm (10 inches) in diameter, at any speed up to and including 32 km/h (20 mph).

S9.2 Requirements. Each vehicle shall meet these vehicle-to-pole test requirements when tested under the conditions of S10 of this standard. At NHTSA's option, either the 50th percentile adult male test dummy (ES-2re dummy, 49 CFR Part 572 Subpart U) or the 5th percentile adult female test dummy (SID-IIs, 49 CFR Part 572 Subpart V) shall be used in the test. At NHTSA's option, either front outboard seating position shall be tested. The vehicle shall meet the specific requirements at all front outboard seating positions.

S9.2.1 Dynamic performance requirements using the Part 572 Subpart U (ES-2re 50th percentile male) dummy. When using the ES-2re Part 572 Subpart U dummy, use the specifications of S11 of this standard (49 CFR 571.214). When using the dummy, the following performance requirements must be met using measurements in accordance with S11.5.

(a) The HIC shall not exceed 1000 when calculated in accordance with the following formula:

$$HIC = \left[\frac{1}{(t_2 - t_1)} \int_{t_1}^{t_2} a dt \right]^{2.5} (t_2 - t_1)$$

Where the term *a* is the resultant head acceleration at the center of gravity of the dummy head expressed as a multiple of *g* (the acceleration of gravity), and *t*₁ and *t*₂ are any two points in time during the impact which are separated by not more than a 36 millisecond time interval and where *t*₁ is less than *t*₂.

(b) Thorax. The deflection of any of the upper, middle, and lower ribs, shall not exceed 44 mm (1.65 inches).

(c) Force measurements.

(1) The sum of the front, middle and rear abdominal forces, shall not exceed 2,500 N (562 pounds).

(2) The pubic symphysis force shall not exceed 6,000 N (1,350 pounds).

S9.2.2 Dynamic performance requirements using the Part 572 Subpart V SID-IIs (5th percentile female) dummy. When using the SID-IIs Part 572 Subpart V dummy, use the specifications of S11 of this standard (49 CFR 571.214). When using the dummy, the following performance requirements must be met.

(a) The HIC shall not exceed 1000 when calculated in accordance with the following formula:

$$HIC = \left[\frac{1}{(t_2 - t_1)} \int_{t_1}^{t_2} a dt \right]^{2.5} (t_2 - t_1)$$

Where the term *a* is the resultant head acceleration at the center of gravity of the dummy head expressed as a multiple of *g* (the acceleration of gravity), and *t*₁ and *t*₂ are any two points in time during the impact which are separated by not more than a 36 millisecond time interval and where *t*₁ is less than *t*₂.

(b) Resultant lower spine acceleration must not exceed 82 *g*.

(c) The sum of the acetabular and iliac pelvic forces must not exceed 5,525 N.

S9.2.3 Door opening.

(a) Any side door that is struck by the pole shall not separate totally from the vehicle.

(b) Any door (including a rear hatchback or tailgate) that is not struck by the pole shall meet the following requirements:

(1) The door shall not disengage from the latched position; and

(2) The latch shall not separate from the striker, and the hinge components shall not separate from each other or from their attachment to the vehicle.

(3) Neither the latch nor the hinge systems of the door shall pull out of their anchorages.

S10. General test conditions for determining compliance with vehicle-to-pole requirements. General test conditions for determining compliance with the vehicle-to-pole test are specified below and in S12 of this standard (49 CFR 571.214).

S10.1 Test weight. Each vehicle is loaded as specified in S8.1 of this standard (49 CFR 571.214).

S10.2 Vehicle test attitude. When the vehicle is in its "as delivered," "fully loaded" and "as tested" condition, locate the vehicle on a flat, horizontal surface to determine the vehicle attitude. Use the same level surface or reference plane and the same standard points on the test vehicle when determining the "as delivered," "fully loaded" and "as tested" conditions. Measure the angles relative to a horizontal plane, front-to-rear and from left-to-right for the "as delivered," "fully loaded," and "as tested" conditions. The front-to-rear angle (pitch) is measured along a fixed reference on the driver's and front passenger's door sill. Mark where the angles are taken on the door sill. The left to right angle (roll) is measured along a fixed reference point at the front and rear of the vehicle at the vehicle longitudinal center plane. Mark where the angles are measured. The "as delivered" condition is the vehicle as

received at the test site, with 100 percent of all fluid capacities and all tires inflated to the manufacturer's specifications listed on the vehicle's tire placard. When the vehicle is in its "fully loaded" condition, measure the angle between the driver's door sill and the horizontal, at the same place the "as delivered" angle was measured. The "fully loaded condition" is the test vehicle loaded in accordance with S8.1 of this standard (49 CFR 571.214). The load placed in the cargo area is centered over the longitudinal centerline of the vehicle. The vehicle "as tested" pitch and roll angles are between the "as delivered" and "fully loaded" condition, inclusive.

S10.3 Adjustable seats.

S10.3.1 Driver and front passenger seat set-up for 50th percentile male dummy. The driver and front passenger seats are set up as specified in S8.3.1 of this standard, 49 CFR 571.214.

S10.3.2 Driver and front passenger seat set-up for 49 CFR Part 572 Subpart V 5th percentile female dummy.

S10.3.2.1 Lumbar support adjustment. Position adjustable lumbar supports so that the lumbar support is in its lowest, retracted or deflated adjustment position.

S10.3.2.2 Other seat adjustments. Position any adjustable parts of the seat that provide additional support so that they are in the lowest or non-deployed adjustment position. Position any adjustable head restraint in the lowest and most forward position. Place adjustable seat backs in the manufacturer's nominal design riding position in the manner specified by the manufacturer. If the position is not specified, set the seat back at the first detent rearward of 25° from the vertical.

S10.3.2.3 Seat position adjustment. If the passenger seat does not adjust independently of the driver seat, the driver seat controls the final position of the passenger seat.

S10.3.2.3.1 Using only the controls that primarily move the seat and seat cushion independent of the seat back in the fore and aft directions, move the seat cushion reference point (SCRCP) to the rearmost position. Using any part of any control, other than those just used, determine the full range of angles of the seat cushion reference line and set the seat cushion reference line to the middle of the range. Using any part of any control other than those that primarily move the seat or seat cushion fore and aft, while maintaining the seat cushion reference line angle, place the SCRCP to its lowest position.

S10.3.2.3.2 Using only the control that primarily moves the seat fore and

aft, move the seat reference point to the most forward position.

S10.3.2.3.3 If the seat or seat cushion height is adjustable, other than by the controls that primarily move the seat or seat cushion fore and aft, set the seat reference point to the midpoint height, with the seat cushion reference line angle set as close as possible to the angle determined in S10.3.2.3.1. Mark location of the seat for future reference.

S10.4 *Positioning dummies for the vehicle-to-pole test.*

(a) *50th percentile male test dummy* (49 CFR Part 572 Subpart U *ES-2re dummy*). The 50th percentile male test dummy is positioned in the front outboard seating position on the struck side of the vehicle in accordance with the provisions of S12.2 of this standard, 49 CFR 571.214.

(b) *5th percentile female test dummy* (49 CFR Part 572 Subpart V *SID-IIs dummy*). The 5th percentile female test dummy is positioned in the front outboard seating positions on the struck side of the vehicle in accordance with the provisions of S12.3 of this standard, 49 CFR 571.214.

S10.5 *Adjustable steering wheel.* Adjustable steering controls are adjusted so that the steering wheel hub is at the geometric center of the locus it describes when it is moved through its full range of driving positions. If there is no setting detent in the mid-position, lower the steering wheel to the detent just below the mid-position.

S10.6 *Windows and sunroofs.* Movable vehicle windows and vents are placed in the fully closed position on the struck side of the vehicle. Any sunroof is placed in the fully closed position.

S10.7 *Convertible tops.* Convertibles and open-body type vehicles have the top, if any, in place in the closed passenger compartment configuration.

S10.8 *Doors.* Doors, including any rear hatchback or tailgate, are fully closed and latched but not locked.

S10.9 *Transmission and brake engagement.* For a vehicle equipped with a manual transmission, the transmission is placed in second gear. For a vehicle equipped with an automatic transmission, the transmission is placed in neutral. For all vehicles, the parking brake is engaged.

S10.10 *Rigid pole.* The rigid pole is a vertical metal structure beginning no more than 102 millimeters (4 inches) above the lowest point of the tires on the striking side of the test vehicle when the vehicle is loaded as specified in S8.1 and extending above the highest point of the roof of the test vehicle. The pole is 254 mm (10 inches) \pm 6 mm (0.25 in) in diameter and set off from any

mounting surface, such as a barrier or other structure, so that the test vehicle will not contact such a mount or support at any time within 100 milliseconds of the initiation of vehicle to pole contact.

S10.11 *Impact reference line.* The impact reference line is located on the striking side of the vehicle at the intersection of the vehicle exterior and a vertical plane passing through the center of gravity of the head of the dummy seated in accordance with S12 in the front outboard designated seating position. The vertical plane forms an angle of 285 (or 75) degrees with the vehicle's longitudinal centerline for the right (or left) side impact test. The angle is measured counterclockwise from the vehicle's positive X-axis as defined in S10.13.

S10.12 *Impact configuration.*

S10.12.1 The rigid pole is stationary.

S10.12.2 The test vehicle is propelled sideways so that its line of forward motion forms an angle of 285 (or 75) degrees (\pm 3 degrees) for the right (or left) side impact with the vehicle's longitudinal centerline. The angle is measured counterclockwise from the vehicle's positive X-axis as defined in S10.13. The impact reference line is aligned with the center line of the rigid pole surface, as viewed in the direction of vehicle motion, so that, when the vehicle-to-pole contact occurs, the center line contacts the vehicle area bounded by two vertical planes parallel to and 38 mm (1.5 inches) forward and aft of the impact reference line.

S10.13 *Vehicle reference coordinate system.* The vehicle reference coordinate system is an orthogonal coordinate system consisting of three axes, a longitudinal axis (X), a transverse axis (Y), and a vertical axis (Z). X and Y are in the same horizontal plane and Z passes through the intersection of X and Y. The origin of the system is at the center of gravity of the vehicle. The X-axis is parallel to the longitudinal centerline of the vehicle and is positive to the vehicle front end and negative to the rear end. The Y-axis is positive to the left side of the vehicle and negative to the right side. The Z-axis is positive above the X-Y plane and negative below it.

S11 *Anthropomorphic test dummies.* The anthropomorphic test dummies used to evaluate a vehicle's performance in the moving deformable barrier and vehicle-to-pole tests are specified in 49 CFR part 572. In a test in which the test vehicle is to be struck on its left side, each dummy is to be configured and instrumented to be struck on its left side, in accordance with part 572. In a test in which the test

vehicle is to be struck on its right side, each dummy is to be configured and instrumented to be struck on its right side, in accordance with part 572.

S11.1 *Clothing.*

(a) *50th percentile male.* Each test dummy representing a 50th percentile male is clothed in formfitting cotton stretch garments with short sleeves and midcalf length pants. Each foot of the test dummy is equipped with a size 11EEE shoe, which meets the configuration size, sole, and heel thickness specifications of MIL-S-13192 (1976) and weighs 0.68 ± 0.09 kilograms (1.25 \pm 0.2 lb).

(b) *5th percentile female.* The 49 CFR Part 572 Subpart V test dummy representing a 5th percentile female is clothed in formfitting cotton stretch garments with short sleeves and about the knee length pants. Each foot has on a size 7.5W shoe that meets the configuration and size specifications of MIL-S-2171E or its equivalent.

S11.2 *Limb joints.*

(a) For the 50th percentile male dummy, set the limb joints at between 1 and 2 g. Adjust the leg joints with the torso in the supine position. Adjust the knee and ankle joints so that they just support the lower leg and the foot when extended horizontally (1 to 2 g adjustment).

(b) For the 49 CFR Part 572 Subpart V 5th percentile female dummy, set the limb joints at slightly above 1 g, barely restraining the weight of the limb when extended horizontally. The force needed to move a limb segment does not exceed 2 g throughout the range of limb motion. Adjust the leg joints with the torso in the supine position.

S11.3 The stabilized temperature of the test dummy at the time of the test is at any temperature between 20.6 degrees C and 22.2 degrees C.

S11.4 *Acceleration data.*

Accelerometers are installed on the head, rib, spine and pelvis components of various dummies as required to meet the injury criteria of the standard. Accelerations measured from different dummy components may use different filters and processing methods.

S11.5 *Processing Data.*

(a) *Subpart F (SID) test dummy.*

(1) Process the acceleration data from the accelerometers mounted on the ribs, spine and pelvis of the Subpart F dummy with the FIR100 software specified in 49 CFR 572.44(d). Process the data in the following manner:

(i) Filter the data with a 300 Hz, SAE Class 180 filter;

(ii) Subsample the data to a 1600 Hz sampling rate;

(iii) Remove the bias from the subsampled data; and

(iv) Filter the data with the FIR100 software specified in 49 CFR 572.44(d), which has the following characteristics—

- (A) Passband frequency 100 Hz.
- (B) Stopband frequency 189 Hz.
- (C) Stopband gain - 50 db.
- (D) Passband ripple 0.0225 db.
- (2) [Reserved.]

(b) *Subpart U (ES-2re 50th percentile male) test dummy.*

(1) The rib deflection data are filtered at channel frequency class 600 Hz. Abdominal and pubic force data are filtered at channel frequency class of 600 Hz.

(2) The acceleration data from the accelerometers installed inside the skull cavity of the ES-2re test dummy are filtered at channel frequency class of 1000 Hz.

(c) *Subpart V (SID-IIs 5th percentile female) test dummy.*

(1) The acceleration data from the accelerometers installed inside the skull cavity of the SID-IIs test dummy are filtered at channel frequency class of 1000 Hz.

(2) The acceleration data from the accelerometers installed on the lower spine of the SID-IIs test dummy are filtered at channel frequency class of 180 Hz.

(3) The iliac and acetabular forces from load cells installed in the pelvis of the SID-IIs are filtered at channel frequency class of 600 Hz.

S12 Positioning procedures for the anthropomorphic test dummies.

S12.1 50th percentile male test dummy—49 CFR Part 572 Subpart F (SID). Position a correctly configured test dummy, conforming to the applicable requirements of part 572 Subpart F of this chapter, in the front outboard seating position on the side of the test vehicle to be struck by the moving deformable barrier and, if the vehicle has a second seat, position another conforming test dummy in the second seat outboard position on the same side of the vehicle, as specified in S12.1.3. Each test dummy is restrained using all available belt systems in all seating positions where such belt restraints are provided. Adjustable belt anchorages are placed at the mid-adjustment position. In addition, any folding armrest is retracted. Additional positioning procedures are specified below.

S12.1.1 Positioning a Part 572 Subpart F (SID) dummy in the driver position.

(a) *Torso.* Hold the dummy's head in place and push laterally on the non-impacted side of the upper torso in a single stroke with a force of 66.7–89.0 N (15–20 lb) towards the impacted side.

(1) For a bench seat. The upper torso of the test dummy rests against the seat back. The midsagittal plane of the test dummy is vertical and parallel to the vehicle's longitudinal centerline, and passes through the center of the steering wheel.

(2) For a bucket seat. The upper torso of the test dummy rests against the seat back. The midsagittal plane of the test dummy is vertical and parallel to the vehicle's longitudinal centerline, and coincides with the longitudinal centerline of the bucket seat.

(b) *Pelvis.*

(1) *H-point.* The H-points of each test dummy coincide within 12.7 mm ($\frac{1}{2}$ inch) in the vertical dimension and 12.7 mm ($\frac{1}{2}$ inch) in the horizontal dimension of a point that is located 6.4 mm ($\frac{1}{4}$ inch) below the position of the H-point determined by using the equipment for the 50th percentile and procedures specified in SAE J826 (1980) (incorporated by reference; see 49 CFR 571.5), except that Table 1 of SAE J826 is not applicable. The length of the lower leg and thigh segments of the H-point machine are adjusted to 414 and 401 mm (16.3 and 15.8 inches), respectively.

(2) *Pelvic angle.* As determined using the pelvic angle gauge (GM drawing 78051–532 incorporated by reference in part 572, Subpart E of this chapter) which is inserted into the H-point gauging hole of the dummy, the angle of the plane of the surface on the lumbar-pelvic adaptor on which the lumbar spine attaches is 23 to 25 degrees from the horizontal, sloping upward toward the front of the vehicle.

(3) *Legs.* The upper legs of each test dummy rest against the seat cushion to the extent permitted by placement of the feet. The left knee of the dummy is positioned such that the distance from the outer surface of the knee pivot bolt to the dummy's midsagittal plane is 152.4 mm (6.0 inches). To the extent practicable, the left leg of the test dummy is in a vertical longitudinal plane.

(4) *Feet.* The right foot of the test dummy rests on the undepressed accelerator with the heel resting as far forward as possible on the floorpan. The left foot is set perpendicular to the lower leg with the heel resting on the floorpan in the same lateral line as the right heel.

S12.1.2 Positioning a Part 572 Subpart F (SID) dummy in the front outboard seating position.

(a) *Torso.* Hold the dummy's head in place and push laterally on the non-impacted side of the upper torso in a single stroke with a force of 66.7–89.0 N (15–20 lb) towards the impacted side.

(1) For a bench seat. The upper torso of the test dummy rests against the seat back. The midsagittal plane of the test dummy is vertical and parallel to the vehicle's longitudinal centerline, and the same distance from the vehicle's longitudinal centerline as would be the midsagittal plane of a test dummy positioned in the driver position under S12.1.1(a)(1).

(2) For a bucket seat. The upper torso of the test dummy rests against the seat back. The midsagittal plane of the test dummy is vertical and parallel to the vehicle's longitudinal centerline, and coincides with the longitudinal centerline of the bucket seat.

(b) *Pelvis.*

(1) *H-point.* The H-points of each test dummy coincide within 12.7 mm ($\frac{1}{2}$ inch) in the vertical dimension and 12.7 mm ($\frac{1}{2}$ inch) in the horizontal dimension of a point that is located 6.4 mm ($\frac{1}{4}$ inch) below the position of the H-point determined by using the equipment for the 50th percentile and procedures specified in SAE J826 (1980) (incorporated by reference; see 49 CFR 571.5), except that Table 1 of SAE J826 is not applicable. The length of the lower leg and thigh segments of the H-point machine are adjusted to 414 and 401 mm (16.3 and 15.8 inches), respectively.

(2) *Pelvic angle.* As determined using the pelvic angle gauge (GM drawing 78051–532 incorporated by reference in part 572, Subpart E of this chapter) which is inserted into the H-point gauging hole of the dummy, the angle of the plane of the surface on the lumbar-pelvic adaptor on which the lumbar spine attaches is 23 to 25 degrees from the horizontal, sloping upward toward the front of the vehicle.

(c) *Legs.* The upper legs of each test dummy rest against the seat cushion to the extent permitted by placement of the feet. The initial distance between the outboard knee clevis flange surfaces is 292 mm (11.5 inches). To the extent practicable, both legs of the test dummies in outboard passenger positions are in vertical longitudinal planes. Final adjustment to accommodate placement of feet in accordance with S12.1.2(d) for various passenger compartment configurations is permitted.

(d) *Feet.* The feet of the test dummy are placed on the vehicle's toeboard with the heels resting on the floorpan as close as possible to the intersection of the toeboard and floorpan. If the feet cannot be placed flat on the toeboard, they are set perpendicular to the lower legs and placed as far forward as possible so that the heels rest on the floorpan.

S12.1.3 Positioning a Part 572 Subpart F (SID) dummy in the rear outboard seating positions.

(a) *Torso.* Hold the dummy's head in place and push laterally on the non-impacted side of the upper torso in a single stroke with a force of 66.7–89.0 N (15–20 lb) towards the impacted side.

(1) For a bench seat. The upper torso of the test dummy rests against the seat back. The midsagittal plane of the test dummy is vertical and parallel to the vehicle's longitudinal centerline, and, if possible, the same distance from the vehicle's longitudinal centerline as the midsagittal plane of a test dummy positioned in the driver position under S12.1.1(a)(1). If it is not possible to position the test dummy so that its midsagittal plane is parallel to the vehicle longitudinal centerline and is at this distance from the vehicle's longitudinal centerline, the test dummy is positioned so that some portion of the test dummy just touches, at or above the seat level, the side surface of the vehicle, such as the upper quarter panel, an armrest, or any interior trim (i.e., either the broad trim panel surface or a smaller, localized trim feature).

(2) For a bucket or contoured seat. The upper torso of the test dummy rests against the seat back. The midsagittal plane of the test dummy is vertical and parallel to the vehicle's longitudinal centerline, and coincides with the longitudinal centerline of the bucket or contoured seat.

(b) Pelvis.

(1) H-point. The H-points of each test dummy coincide within 12.7 mm ($\frac{1}{2}$ inch) in the vertical dimension and 12.7 mm ($\frac{1}{2}$ inch) in the horizontal dimension of a point that is located 6.4 mm ($\frac{1}{4}$ inch) below the position of the H-point determined by using the equipment for the 50th percentile and procedures specified in SAE J826 (1980) (incorporated by reference; see 49CFR 571.5), except that Table 1 of SAE J826 is not applicable. The length of the lower leg and thigh segments of the H-point machine are adjusted to 414 and 401 mm (16.3 and 15.8 inches), respectively.

(2) Pelvic angle. As determined using the pelvic angle gauge (GM drawing 78051–532 incorporated by reference in part 572, Subpart E of this chapter) which is inserted into the H-point gauging hole of the dummy, the angle of the plane of the surface on the lumbar-pelvic adaptor on which the lumbar spine attaches is 23 to 25 degrees from the horizontal, sloping upward toward the front of the vehicle.

(c) *Legs.* Rest the upper legs of each test dummy against the seat cushion to the extent permitted by placement of the

feet. The initial distance between the outboard knee clevis flange surfaces is 292 mm (11.5 inches). To the extent practicable, both legs of the test dummies in outboard passenger positions are in vertical longitudinal planes. Final adjustment to accommodate placement of feet in accordance with S12.1.3(d) for various passenger compartment configurations is permitted.

(d) *Feet.* Place the feet of the test dummy flat on the floorpan and beneath the front seat as far as possible without front seat interference. If necessary, the distance between the knees may be changed in order to place the feet beneath the seat.

S12.2 50th percentile male test dummy—49 CFR Part 572 Subpart U (ES–2re).

S12.2.1 Positioning an ES–2re dummy in all seating positions. Position a correctly configured ES–2re test dummy, conforming to the applicable requirements of part 572 of this chapter, in the front outboard seating position on the side of the test vehicle to be struck by the moving deformable barrier or pole. Restrain the test dummy using all available belt systems in the seating positions where the belt restraints are provided. Place adjustable belt anchorages at the mid-adjustment position. Retract any folding armrest.

(a) Upper torso.

(1) The plane of symmetry of the dummy coincides with the vertical median plane of the specified seating position.

(2) Bend the upper torso forward and then lay it back against the seat back. Set the shoulders of the dummy fully rearward.

(b) *Pelvis.* Position the pelvis of the dummy according to the following:

(1) Position the pelvis of the dummy such that a lateral line passing through the dummy H-points is perpendicular to the longitudinal center plane of the seat. The line through the dummy H-points is horizontal with a maximum inclination of ± 2 degrees. The dummy may be equipped with tilt sensors in the thorax and the pelvis. These instruments can help to obtain the desired position.

(2) The correct position of the dummy pelvis may be checked relative to the H-point of the H-point Manikin by using the M3 holes in the H-point back plates at each side of the ES–2re pelvis. The M3 holes are indicated with "Hm". The "Hm" position should be in a circle with a radius of 10 mm (0.39 inches) round the H-point of the H-point Manikin.

(c) *Arms.* For the driver seating position and for the front outboard

seating position, place the dummy's upper arms such that the angle between the projection of the arm centerline on the mid-sagittal plane of the dummy and the torso reference line is $40^\circ \pm 5^\circ$. The torso reference line is defined as the thoracic spine centerline. The shoulder-arm joint allows for discrete arm positions at 0, 40, and 90 degree settings forward of the spine.

(d) *Legs and Feet.* Position the legs and feet of the dummy according to the following:

(1) For the driver's seating position, without inducing pelvis or torso movement, place the right foot of the dummy on the un-pressed accelerator pedal with the heel resting as far forward as possible on the floor pan. Set the left foot perpendicular to the lower leg with the heel resting on the floor pan in the same lateral line as the right heel. Set the knees of the dummy such that their outside surfaces are 150 ± 10 mm (5.9 ± 0.4 inches) from the plane of symmetry of the dummy. If possible within these constraints, place the thighs of the dummy in contact with the seat cushion.

(2) For other seating positions, without inducing pelvis or torso movement, place the heels of the dummy as far forward as possible on the floor pan without compressing the seat cushion more than the compression due to the weight of the leg. Set the knees of the dummy such that their outside surfaces are 150 ± 10 mm (5.9 ± 0.4 inches) from the plane of symmetry of the dummy.

S12.3 5th percentile female test dummy—49 CFR Part 572 Subpart V (SID–IIs). Position a correctly configured 5th percentile female Part 572 Subpart V (SID–IIs) test dummy, conforming to the applicable requirements of part 572 of this chapter, in the front outboard seating position on the side of the test vehicle to be struck by the pole and, for the moving deformable barrier, if the vehicle has a second seat, position a conforming test dummy in the second seat outboard position on the same side of the vehicle (side to be struck) as specified in S12.3.4. Retract any folding armrest. Additional procedures are specified below.

S12.3.1 General provisions and definitions.

(a) Measure all angles with respect to the horizontal plane unless otherwise stated.

(b) Adjust the SID–IIs dummy's neck bracket to align the zero degree index marks.

(c) Other seat adjustments. The longitudinal centerline of a bucket seat cushion passes through the SgRP and is

parallel to the longitudinal centerline of the vehicle.

(d) *Driver and passenger manual belt adjustment.* Use all available belt systems. Place adjustable belt anchorages at the nominal position for a 5th percentile adult female suggested by the vehicle manufacturer.

(e) *Definitions.*

(1) The term “midsagittal plane” refers to the vertical plane that separates the dummy into equal left and right halves.

(2) The term “vertical longitudinal plane” refers to a vertical plane parallel to the vehicle’s longitudinal centerline.

(3) The term “vertical plane” refers to a vertical plane, not necessarily parallel to the vehicle’s longitudinal centerline.

(4) The term “transverse instrumentation platform” refers to the transverse instrumentation surface inside the dummy’s skull casting to which the neck load cell mounts. This surface is perpendicular to the skull cap’s machined inferior-superior mounting surface.

(5) The term “thigh” refers to the femur between, but not including, the knee and the pelvis.

(6) The term “leg” refers to the lower part of the entire leg including the knee.

(7) The term “foot” refers to the foot, including the ankle.

(8) For leg and thigh angles, use the following references:

(i) Thigh—a straight line on the thigh skin between the center of the ½-13 UNC-2B tapped hole in the upper leg femur clamp and the knee pivot shoulder bolt.

(ii) Leg—a straight line on the leg skin between the center of the ankle shell and the knee pivot shoulder bolt.

(9) The term “seat cushion reference point” (SCRCP) means a point placed on the outboard side of the seat cushion at a horizontal distance between 150 mm (5.9 in) and 250 mm (9.8 in) from the front edge of the seat used as a guide in positioning the seat.

(10) The term “seat cushion reference line” means a line on the side of the seat cushion, passing through the seat cushion reference point, whose projection in the vehicle vertical longitudinal plane is straight and has a known angle with respect to the horizontal.

S12.3.2 5th percentile female driver dummy positioning.

(a) *Driver torso/head/seat back angle positioning.*

(1) With the seat in the position determined in S10.3.2, use only the control that moves the seat fore and aft to place the seat in the rearmost position. If the seat cushion reference line angle automatically changes as the

seat is moved from the full forward position, maintain, as closely as possible, the seat cushion reference line angle determined in S10.3.2.3.3, for the final forward position when measuring the pelvic angle as specified in S12.3.3(a)(11). The seat cushion reference line angle position may be achieved through the use of any seat or seat cushion adjustments other than that which primarily moves the seat or seat cushion fore-aft.

(2) Fully recline the seat back, if adjustable. Install the dummy into the driver’s seat, such that when the legs are positioned 120 degrees to the thighs, the calves of the legs are not touching the seat cushion.

(3) Bucket seats. Center the dummy on the seat cushion so that its midsagittal plane is vertical and passes through the SgRP within ± 10 mm (± 0.4 in).

(4) Bench seats. Position the midsagittal plane of the dummy vertical and parallel to the vehicle’s longitudinal centerline and aligned within ± 10 mm (± 0.4 in) of the center of the steering wheel rim.

(5) Hold the dummy’s thighs down and push rearward on the upper torso to maximize the dummy’s pelvic angle.

(6) Place the legs at 120 degrees to the thighs. Set the initial transverse distance between the longitudinal centerlines at the front of the dummy’s knees at 160 to 170 mm (6.3 to 6.7 in), with the thighs and legs of the dummy in vertical planes. Push rearward on the dummy’s knees to force the pelvis into the seat so there is no gap between the pelvis and the seat back or until contact occurs between the back of the dummy’s calves and the front of the seat cushion.

(7) Gently rock the upper torso relative to the lower torso laterally in a side to side motion three times through a ± 5 degree arc (approximately 51 mm (2 in) side to side).

(8) If needed, extend the legs slightly so that the feet are not in contact with the floor pan. Let the thighs rest on the seat cushion to the extent permitted by the foot movement. Keeping the leg and the thigh in a vertical plane, place the foot in the vertical longitudinal plane that passes through the centerline of the accelerator pedal. Rotate the left thigh outboard about the hip until the center of the knee is the same distance from the midsagittal plane of the dummy as the right knee ± 5 mm (± 0.2 in). Using only the control that moves the seat fore and aft, attempt to return the seat to the full forward position. If either of the dummy’s legs first contacts the steering wheel, then adjust the steering wheel, if adjustable, upward until contact with the steering wheel is avoided. If the

steering wheel is not adjustable, separate the knees enough to avoid steering wheel contact. Proceed with moving the seat forward until either the leg contacts the vehicle interior or the seat reaches the full forward position. (The right foot may contact and depress the accelerator and/or change the angle of the foot with respect to the leg during seat movement.) If necessary to avoid contact with the vehicle’s brake or clutch pedal, rotate the test dummy’s left foot about the leg. If there is still interference, rotate the left thigh outboard about the hip the minimum distance necessary to avoid pedal interference. If a dummy leg contacts the vehicle interior before the full forward position is attained, position the seat at the next detent where there is no contact. If the seat is a power seat, move the seat fore and aft to avoid contact while assuring that there is a maximum of 5 mm (0.2 in) distance between the vehicle interior and the point on the dummy that would first contact the vehicle interior. If the steering wheel was moved, return it to the position described in S10.5. If the steering wheel contacts the dummy’s leg(s) prior to attaining this position, adjust it to the next higher detent, or if infinitely adjustable, until there is 5 mm (0.2 in) clearance between the wheel and the dummy’s leg(s).

(9) For vehicles without adjustable seat backs, adjust the lower neck bracket to level the head as much as possible. For vehicles with adjustable seat backs, while holding the thighs in place, rotate the seat back forward until the transverse instrumentation platform of the head is level to within ± 0.5 degree, making sure that the pelvis does not interfere with the seat bight. Inspect the abdomen to ensure that it is properly installed. If the torso contacts the steering wheel, adjust the steering wheel in the following order until there is no contact: telescoping adjustment, lowering adjustment, raising adjustment. If the vehicle has no adjustments or contact with the steering wheel cannot be eliminated by adjustment, position the seat at the next detent where there is no contact with the steering wheel as adjusted in S10.5. If the seat is a power seat, position the seat to avoid contact while assuring that there is a maximum of 5 mm (0.2 in) distance between the steering wheel as adjusted in S10.5 and the point of contact on the dummy.

(10) If it is not possible to achieve the head level within ± 0.5 degrees, minimize the angle.

(11) Measure and set the dummy’s pelvic angle using the pelvic angle gage. The angle is set to 20.0 degrees ± 2.5

degrees. If this is not possible, adjust the pelvic angle as close to 20.0 degrees as possible while keeping the transverse instrumentation platform of the head as level as possible by adjustments specified in S12.3.2(a)(9) and (10).

(12) If the dummy is contacting the vehicle interior after these adjustments, move the seat rearward until there is a maximum of 5 mm (0.2 in) between the contact point of the dummy and the interior of the vehicle or if it has a manual seat adjustment, to the next rearward detent position. If after these adjustments, the dummy contact point is more than 5 mm (0.2 in) from the vehicle interior and the seat is still not in its forwardmost position, move the seat forward until the contact point is 5 mm (0.2 in) or less from the vehicle interior, or if it has a manual seat adjustment, move the seat to the closest detent position without making contact, or until the seat reaches its forwardmost position, whichever occurs first.

(b) *Driver foot positioning.*

(1) If the vehicle has an adjustable accelerator pedal, adjust it to the full forward position. If the heel of the right foot can contact the floor pan, follow the positioning procedure in S12.3.2(b)(1)(i). If not, follow the positioning procedure in S12.3.2(b)(1)(ii).

(i) Rest the right foot of the test dummy on the un-depressed accelerator pedal with the rearmost point of the heel on the floor pan in the plane of the pedal. If the foot cannot be placed on the accelerator pedal, set it initially perpendicular to the leg and then place it as far forward as possible in the direction of the pedal centerline with the rearmost point of the heel resting on the floor pan. If the vehicle has an adjustable accelerator pedal and the right foot is not touching the accelerator pedal when positioned as above, move the pedal rearward until it touches the right foot. If the accelerator pedal in the full rearward position still does not touch the foot, leave the pedal in that position.

(ii) Extend the foot and lower leg by decreasing the knee flexion angle until any part of the foot contacts the un-depressed accelerator pedal or the highest part of the foot is at the same height as the highest part of the pedal. If the vehicle has an adjustable accelerator pedal and the right foot is not touching the accelerator pedal when positioned as above, move the pedal rearward until it touches the right foot.

(2) If the ball of the foot does not contact the pedal, increase the ankle plantar flexion angle such that the toe of the foot contacts or is as close as

possible to contact with the un-depressed accelerator pedal.

(3) If, in its final position, the heel is off of the vehicle floor, a spacer block is used under the heel to support the final foot position. The surface of the block in contact with the heel has an inclination of 30 degrees, measured from the horizontal, with the highest surface towards the rear of the vehicle.

(4) Place the left foot on the toe-board with the rearmost point of the heel resting on the floor pan as close as possible to the point of intersection of the planes described by the toe-board and floor pan, and not on or in contact with the vehicle's brake pedal, clutch pedal, wheel-well projection or foot rest, except as provided in S12.3.2(b)(6).

(5) If the left foot cannot be positioned on the toe board, place the foot perpendicular to the lower leg centerline as far forward as possible with the heel resting on the floor pan.

(6) If the left foot does not contact the floor pan, place the foot parallel to the floor and place the leg perpendicular to the thigh as possible. If necessary to avoid contact with the vehicle's brake pedal, clutch pedal, wheel-well, or foot rest, use the three foot position adjustments listed in S12.3.2(b)(1)(i)-(ii). The adjustment options are listed in priority order, with each subsequent option incorporating the previous. In making each adjustment, move the foot the minimum distance necessary to avoid contact. If it is not possible to avoid all prohibited foot contact, priority is given to avoiding brake or clutch pedal contact:

(i) Rotate (abduction/adduction) the test dummy's left foot about the lower leg;

(ii) Planar flex the foot;

(iii) Rotate the left leg outboard about the hip.

(c) *Driver arm/hand positioning.*

(1) Place the dummy's upper arm such that the angle between the projection of the arm centerline on the midsagittal plane of the dummy and the torso reference line is $40^\circ \pm 5^\circ$. The torso reference line is defined as the thoracic spine centerline. The shoulder-arm joint allows for discrete arm positions at 0, ± 40 , ± 90 , ± 140 , and 180 degree settings where positive is forward of the spine.

(2) [Reserved.]

S12.3.3 *5th percentile female front passenger dummy positioning*

(a) *Passenger torso/head/seat back angle positioning.*

(1) With the seat at the mid-height in the full-forward position determined in S10.3.2, use only the control that primarily moves the seat fore and aft to place the seat in the rearmost position, without adjusting independent height

controls. If the seat cushion reference angle automatically changes as the seat is moved from the full forward position, maintain, as closely as possible, the seat cushion reference line angle determined in S10.3.2.3.3, for the final forward position when measuring the pelvic angle as specified in S12.3.3(a)(11). The seat cushion reference line angle position may be achieved through the use of any seat or seat cushion adjustments other than that which primarily moves the seat or seat cushion fore-aft.

(2) Fully recline the seat back, if adjustable. Place the dummy into the passenger's seat, such that when the legs are positioned 120 degrees to the thighs, the calves of the legs are not touching the seat cushion.

(3) Bucket seats. Place the dummy on the seat cushion so that its midsagittal plane is vertical and passes through the SgRP within ± 10 mm (± 0.4 in).

(4) Bench seats. Position the midsagittal plane of the dummy vertical and parallel to the vehicle's longitudinal centerline and the same distance from the vehicle's longitudinal centerline, within $+ 10$ mm (± 0.4 in), as the midsagittal plane of the driver dummy.

(5) Hold the dummy's thighs down and push rearward on the upper torso to maximize the dummy's pelvic angle.

(6) Place the legs at 120 degrees to the thighs. Set the initial transverse distance between the longitudinal centerlines at the front of the dummy's knees at 160 to 170 mm (6.3 to 6.7 in), with the thighs and legs of the dummy in vertical planes. Push rearward on the dummy's knees to force the pelvis into the seat so there is no gap between the pelvis and the seat back or until contact occurs between the back of the dummy's calves and the front of the seat cushion.

(7) Gently rock the upper torso relative to the lower torso laterally in a side to side motion three times through a ± 5 degree arc (approximately 51 mm (2 in) side to side).

(8) If needed, extend the legs slightly so that the feet are not in contact with the floor pan. Let the thighs rest on the seat cushion to the extent permitted by the foot movement. With the feet perpendicular to the legs, place the heels on the floor pan. If a heel will not contact the floor pan, place it as close to the floor pan as possible. Using only the control that primarily moves the seat fore and aft, attempt to return the seat to the full forward position. If a dummy leg contacts the vehicle interior before the full forward position is attained, position the seat at the next detent where there is no contact. If the seats are power seats, position the seat to avoid contact while assuring that there is a

maximum of 5 mm (0.2 in) distance between the vehicle interior and the point on the dummy that would first contact the vehicle interior.

(9) For vehicles without adjustable seat backs, adjust the lower neck bracket to level the head as much as possible. For vehicles with adjustable seat backs, while holding the thighs in place, rotate the seat back forward until the transverse instrumentation platform of the head is level to within ± 0.5 degree, making sure that the pelvis does not interfere with the seat bight. Inspect the abdomen to ensure that it is properly installed.

(10) If it is not possible to achieve the head level within ± 0.5 degrees, minimize the angle.

(11) Measure and set the dummy's pelvic angle using the pelvic angle gage. The angle is set to 20.0 degrees ± 2.5 degrees. If this is not possible, adjust the pelvic angle as close to 20.0 degrees as possible while keeping the transverse instrumentation platform of the head as level as possible by adjustments specified in S12.3.3(a)(9) and (10).

(12) If the dummy is contacting the vehicle interior after these adjustments, move the seat rearward until there is a maximum of 5 mm (0.2 in) between the contact point of the dummy and the interior of the vehicle or if it has a manual seat adjustment, to the next rearward detent position. If after these adjustments, the dummy contact point is more than 5 mm (0.2 in) from the vehicle interior and the seat is still not in its forwardmost position, move the seat forward until the contact point is 5 mm (0.2 in) or less from the vehicle interior, or if it has a manual seat adjustment, move the seat to the closest detent position without making contact, or until the seat reaches its forwardmost position, whichever occurs first.

(b) *Passenger foot positioning.*

(1) Place the front passenger's feet flat on the toe board.

(2) If the feet cannot be placed flat on the toe board, set them perpendicular to the leg center lines and place them as far forward as possible with the heels resting on the floor pan.

(3) Place the rear seat passenger's feet flat on the floor pan and beneath the front seat as far as possible without front seat interference.

(c) *Passenger arm/hand positioning.*

Place the dummy's upper arm such that the angle between the projection of the arm centerline on the mid-sagittal plane of the dummy and the torso reference line is $40^\circ \pm 5^\circ$. The torso reference line is defined as the thoracic spine centerline. The shoulder-arm joint allows for discrete arm positions at 0,

$\pm 40^\circ$, $\pm 90^\circ$, $\pm 140^\circ$, and 180° degree settings where positive is forward of the spine.

S12.3.4 *5th percentile female in rear outboard seating positions.*

(a) Set the rear outboard seat at the full rearward, full down position determined in S8.3.3.

(b) Fully recline the seat back, if adjustable. Install the dummy into the passenger's seat, such that when the legs are 120 degrees to the thighs, the calves of the legs are not touching the seat cushion.

(c) Place the dummy on the seat cushion so that its midsagittal plane is vertical and coincides with the vertical longitudinal plane through the center of the seating position SgRP within ± 10 mm (± 0.4 mm).

(d) Hold the dummy's thighs down and push rearward on the upper torso to maximize the dummy's pelvic angle.

(e) Place the legs at 120 degrees to the thighs. Set the initial transverse distance between the longitudinal centerlines at the front of the dummy's knees at 160 to 170 mm (6.3 to 6.7 in), with the thighs and legs of the dummy in vertical planes. Push rearward on the dummy's knees to force the pelvis into the seat so there is no gap between the pelvis and the seat back or until contact occurs between the back of the dummy's calves and the front of the seat cushion.

(f) Gently rock the upper torso laterally side to side three times through a ± 5 degree arc (approximately 51 mm (2 in) side to side).

(g) If needed, extend the legs slightly so that the feet are not in contact with the floor pan. Let the thighs rest on the seat cushion to the extent permitted by the foot movement. With the feet perpendicular to the legs, place the heels on the floor pan. If a heel will not contact the floor pan, place it as close to the floor pan as possible.

(h) For vehicles without adjustable seat backs, adjust the lower neck bracket to level the head as much as possible. For vehicles with adjustable seat backs, while holding the thighs in place, rotate the seat back forward until the transverse instrumentation platform of the head is level to within ± 0.5 degrees, making sure that the pelvis does not interfere with the seat bight. Inspect the abdomen to insure that it is properly installed.

(i) If it is not possible to orient the head level within ± 0.5 degrees, minimize the angle.

(j) Measure and set the dummy's pelvic angle using the pelvic angle gauge. The angle is set to 20.0 degrees ± 2.5 degrees. If this is not possible, adjust the pelvic angle as close to 20.0 degrees as possible while keeping the transverse instrumentation platform of

the head as level as possible, as specified in S12.3.4(h) and (i).

(k) *Passenger foot positioning.*

(1) Place the passenger's feet flat on the floor pan.

(2) If the either foot does not contact the floor pan, place the foot parallel to the floor and place the leg as perpendicular to the thigh as possible.

(l) *Passenger arm/hand positioning.* Place the rear dummy's upper arm such that the angle between the projection of the arm centerline on the midsagittal plane of the dummy and the torso reference line is $0^\circ \pm 5^\circ$. The torso reference line is defined as the thoracic spine centerline. The shoulder-arm joint allows for discrete arm positions at 0, $\pm 40^\circ$, $\pm 90^\circ$, $\pm 140^\circ$, and 180° degree settings where positive is forward of the spine.

S13 *Phase-in of moving deformable barrier and vehicle-to-pole performance requirements for vehicles manufactured on or after September 1, 2009 and before September 1, 2012.*

S13.1 *Vehicles manufactured on or after September 1, 2009 and before September 1, 2012.* At anytime during the production years ending August 31, 2012 and August 31, 2013, each manufacturer shall, upon request from the Office of Vehicle Safety Compliance, provide information identifying the vehicles (by make, model and vehicle identification number) that have been certified as complying with the moving deformable barrier test with advanced test dummies (S7.2) and vehicle-to-pole test requirements (S9.2) of this standard. The manufacturer's designation of a vehicle as a certified vehicle is irrevocable.

S13.1.1 *Vehicles manufactured on or after September 1, 2009 and before September 1, 2010.* Subject to S13.4, for vehicles manufactured on or after September 1, 2009 and before September 1, 2010, the number of vehicles complying with S7.2 and S9.2 shall be not less than 20 percent of:

(a) The manufacturer's average annual production of vehicles manufactured in the three previous production years; or

(b) The manufacturer's production in the current production year.

S13.1.2 *Vehicles manufactured on or after September 1, 2010 and before September 1, 2011.* Subject to S13.4, for vehicles manufactured on or after September 1, 2010 and before September 1, 2011, the number of vehicles complying with S7.2 and S9.2 shall be not less than 50 percent of:

(a) The manufacturer's average annual production of vehicles manufactured in the three previous production years; or

(b) The manufacturer's production in the current production year.

S13.1.3 *Vehicles manufactured on or after September 1, 2011 and before September 1, 2012.* Subject to S13.4, for vehicles manufactured on or after September 1, 2011 and before September 1, 2012, the number of vehicles complying with S7.2 and S9.2 shall be not less than 75 percent of:

- (a) The manufacturer's average annual production of vehicles manufactured in the three previous production years; or
- (b) The manufacturer's production in the current production year.

S13.2 *Vehicles produced by more than one manufacturer.*

S13.2.1 For the purpose of calculating average annual production of vehicles for each manufacturer and the number of vehicles manufactured by each manufacturer under S13.1.1 and S13.1.2, a vehicle produced by more than one manufacturer shall be attributed to a single manufacturer as follows, subject to S13.2.2.

(a) A vehicle that is imported shall be attributed to the importer.

(b) A vehicle manufactured in the United States by more than one manufacturer, one of which also markets the vehicle, shall be attributed to the manufacturer that markets the vehicle.

S13.2.2 A vehicle produced by more than one manufacturer shall be attributed to any one of the vehicle's manufacturers specified by an express written contract, reported to the National Highway Traffic Safety Administration under 49 CFR part 585, between the manufacturer so specified and the manufacturer to which the vehicle would otherwise be attributed under S13.2.1.

S13.3 For the purposes of calculating average annual production of vehicles for each manufacturer and the number of vehicles manufactured by each manufacturer under S13.1.1 and S13.1.2, do not count any vehicle that is excluded by Standard No. 214 from the moving deformable barrier test with the ES-2re or SID-II's test dummies (S7.2) or from the vehicle-to-pole test requirements.

S13.4 *Calculation of complying vehicles.*

(a) For the purposes of calculating the vehicles complying with S13.1.1, a manufacturer may count a vehicle if it is manufactured on or after October 11, 2007, but before September 1, 2010.

(b) For purposes of complying with S13.1.2, a manufacturer may count a vehicle if it—

- (1) Is manufactured on or after October 11, 2007, but before September 1, 2011 and,
- (2) Is not counted toward compliance with S13.1.1.

(c) For purposes of complying with S13.1.3, a manufacturer may count a vehicle if it—

(1) Is manufactured on or after October 11, 2007, but before September 1, 2012 and,

(2) Is not counted toward compliance with S13.1.1 or S13.1.2.

(c) For the purposes of calculating average annual production of vehicles for each manufacturer and the number of vehicles manufactured by each manufacturer, each vehicle that is excluded from having to meet the applicable requirement is not counted.

■ 4. Section 571.301 is amended by revising S6.3(b) and S7.2(b), to read as follows:

§ 571.301 Standard No. 301; Fuel system integrity.

S6.3 *Side moving barrier crash.*

* * *

(b) *Vehicles manufactured on or after September 1, 2004.* When the vehicle is impacted laterally on either side by a moving deformable barrier at 53 ± 1.0 km/h with 49 CFR part 572, subpart F test dummies at positions required for testing by S7.1.1 of Standard 214, under the applicable conditions of S7 of this standard, fuel spillage shall not exceed the limits of S5.5 of this standard.

* * * * *

S7.2 *Side moving barrier test conditions.* * * *

(b) *Vehicles manufactured on or after September 1, 2004.* The side moving deformable barrier crash test conditions are those specified in S8 of Standard 214 (49 CFR 571.214).

■ 5. Section 571.305 is amended by revising S6.3 and S7.5, to read as follows:

§ 571.305 Standard No. 305; Electric-powered vehicles: electrolyte spillage and electrical shock protection.

* * * * *

S6.3 *Side moving deformable barrier impact.* The vehicle must meet the requirements of S5.1, S5.2, and S5.3 when it is impacted from the side by a barrier that conforms to part 587 of this chapter that is moving at any speed up to and including 54 km/h, with 49 CFR part 572, subpart F test dummies positioned in accordance with S7 of Sec. 571.214 of this chapter.

* * * * *

S7.5 *Side moving deformable barrier impact test conditions.* In addition to the conditions of S7.1 and S7.2, the conditions of S8 of Sec. 571.214 of this chapter apply to the conduct of the side moving deformable barrier impact test specified in S6.3.

* * * * *

PART 585—PHASE-IN REPORTING REQUIREMENTS

■ 6. The authority citation for part 585 continues to read as follows:

Authority: 49 U.S.C. 322, 30111, 30115, 30117, and 30166; delegation of authority at 49 CFR 1.50.

■ 7. Part 585 is amended by adding Subpart H to read as follows:

Subpart H—Side Impact Protection Phase-in Reporting Requirements

Sec.	
585.71	Scope.
585.72	Purpose.
585.73	Applicability.
585.74	Definitions.
585.75	Response to inquiries.
585.76	Reporting requirements.
585.77	Records.

Subpart H—Side Impact Protection Phase-in Reporting Requirements

§ 585.71 Scope.

This part establishes requirements for manufacturers of passenger cars, and of trucks, buses and multipurpose passenger vehicles with a gross vehicle weight rating (GVWR) of 4,536 kilograms (kg) (10,000 pounds) or less, to submit a report, and maintain records related to the report, concerning the number of such vehicles that meet the moving deformable barrier test requirements of S7 of Standard No. 214, *Side impact protection* (49 CFR 571.214), and the vehicle-to-pole test requirements of S9 of that standard.

§ 585.72 Purpose.

The purpose of these reporting requirements is to assist the National Highway Traffic Safety Administration in determining whether a manufacturer has complied with the requirements of Standard No. 214, *Side Impact Protection* (49 CFR 571.214).

§ 585.73 Applicability.

This part applies to manufacturers of passenger cars, and of trucks, buses and multipurpose passenger vehicles with a GVWR of 4,536 kg (10,000 lb) or less. However, this part does not apply to vehicles excluded by S2 and S5 of Standard No. 214 (49 CFR 571.214) from the requirements of that standard.

§ 585.74 Definitions.

(a) All terms defined in 49 U.S.C. 30102 are used in their statutory meaning.

(b) *Bus, gross vehicle weight rating or GVWR, multipurpose passenger vehicle, passenger car, and truck* are used as defined in § 571.3 of this chapter.

(c) *Production year* means the 12-month period between September 1 of

one year and August 31 of the following year, inclusive.

(d) *Limited line manufacturer* means a manufacturer that sells three or fewer carlines, as that term is defined in 49 CFR 583.4, in the United States during a production year.

§ 585.75 Response to inquiries.

At anytime during the production years ending August 31, 2010, and August 31, 2013, each manufacturer shall, upon request from the Office of Vehicle Safety Compliance, provide information identifying the vehicles (by make, model and vehicle identification number) that have been certified as complying with the moving deformable barrier and vehicle-to-pole tests of FMVSS No. 214 (49 CFR 571.214). The manufacturer's designation of a vehicle as a certified vehicle is irrevocable.

§ 585.76 Reporting requirements

(a) *Advanced credit phase-in reporting requirements.* (1) Within 60 days after the end of the production years ending August 31, 2008, and August 31, 2009, each manufacturer choosing to certify vehicles manufactured during any of those production years as complying with the upgraded moving deformable barrier (S7.2 of Standard No. 214)(49 CFR 571.214) or vehicle-to-pole requirements (S9) of Standard No. 214 shall submit a

report to the National Highway Traffic Safety Administration providing the information specified in paragraph (c) of this section and in § 585.2 of this part.

(b) *Phase-in reporting requirements.* Within 60 days after the end of each of the production years ending August 31, 2010, August 31, 2011, and August 31, 2012, each manufacturer shall submit a report to the National Highway Traffic Safety Administration concerning its compliance with the moving deformable barrier requirements of S7 of Standard No. 214 and with the vehicle-to-pole requirements of S9 of that Standard for its vehicles produced in that year. Each report shall provide the information specified in paragraph (c) of this section and in section 585.2 of this part.

(c) *Advanced credit phase-in report content—(1) Production of complying vehicles.* With respect to the reports identified in § 585.76(a), each manufacturer shall report for the production year for which the report is filed the number of vehicles, by make and model year, that are certified as meeting the moving deformable barrier test requirements of S7.2 of Standard No. 214, *Side impact protection* (49 CFR 571.214), and the vehicle-to-pole test requirements of S9 of that standard.

(d) *Phase-in report content—(1) Basis for phase-in production goals.* Each manufacturer shall provide the number of vehicles manufactured in the current

production year, or, at the manufacturer's option, in each of the three previous production years. A new manufacturer that is, for the first time, manufacturing passenger cars for sale in the United States must report the number of passenger cars manufactured during the current production year.

(2) *Production of complying vehicles.* Each manufacturer shall report for the production year being reported on, and each preceding production year, to the extent that vehicles produced during the preceding years are treated under Standard No. 214 as having been produced during the production year being reported on, information on the number of passenger vehicles that meet the moving deformable barrier test requirements of S7 of Standard No. 214, *Side Impact Protection* (49 CFR 571.214), and the vehicle-to-pole test requirements of S9 of that standard.

§ 585.77 Records

Each manufacturer shall maintain records of the Vehicle Identification Number for each vehicle for which information is reported under § 585.76 until December 31, 2016.

Issued on: August 30, 2007.

Nicole R. Nason,
Administrator.

[FR Doc. 07-4360 Filed 9-5-07; 8:45 am]

BILLING CODE 4910-59-P