

Actions	Compliance	Procedures
(2) Replace the old engine mount attaching hardware by doing the following: (i) Remove and discard the upper left and upper right engine mount attaching hardware; (ii) Cut out and remove the upholstery and insulation material to allow full metal-to-metal contact of the fuselage tubular frame to the firewall; and (iii) Install the new upper left and upper right engine mount attaching hardware part kits	Within the next 100 hours time-in-service (TIS) after April 9, 2007 (the effective date of this AD).	Follow Mooney Airplane Company, Inc. Service Bulletin M20-292A, dated December 22, 2006.
(3) If you do the actions of paragraph (e)(2) of this AD before the compliance time specified for the action in paragraph (e)(1) of this AD, it terminates the requirement for the action in paragraph (e)(1) of this AD.	As of April 9, 2007 (the effective date of this AD).	Follow Mooney Airplane Company, Inc. Service Bulletin M20-292A, dated December 22, 2006.

(f) Compliance will be acceptable if the above actions are accomplished by following the procedures described in Mooney Airplane Company, Inc. Service Bulletin M20-292, dated September 22, 2006. You may take "unless already done" credit, and no further action per this AD is necessary.

Alternative Methods of Compliance (AMOCs)

(g) The Manager, Fort Worth Airplane Certification Office, FAA, ATTN: Andrew McAnaul, Aerospace Engineer, ASW-150 (c/o MIDO-43), 10100 Reunion Place, Suite 650, San Antonio, Texas 78216; telephone: (210) 308-3365; fax: (210) 308-3370, has the authority to approve AMOCs for this AD, if requested using the procedures found in 14 CFR 39.19.

Related Information

(h) None.

Material Incorporated by Reference

(i) You must use Mooney Airplane Company, Inc. Service Bulletin M20-292A, dated December 22, 2006, to do the actions required by this AD, unless the AD specifies otherwise.

(1) The Director of the Federal Register approved the incorporation by reference of this service information under 5 U.S.C. 552(a) and 1 CFR part 51.

(2) For service information identified in this AD, contact the Mooney Airplane Company, Inc., 165 Al Mooney Road North, Kerrville, TX 78028, telephone: 830-896-6000, or go to: <http://www.mooney.com/images/pdfs/sb-pdf/m20-292a.pdf>.

(3) You may review copies at the FAA, Central Region, Office of the Regional Counsel, 901 Locust, Kansas City, Missouri 64106; or at the National Archives and Records Administration (NARA). For information on the availability of this material at NARA, call 202-741-6030, or go to: http://www.archives.gov/federal_register/code_of_federal_regulations/ibr_locations.html.

Issued in Kansas City, Missouri, on February 21, 2007.

Kim Smith,

Manager, Small Airplane Directorate, Aircraft Certification Service.

[FR Doc. E7-3575 Filed 3-2-07; 8:45 am]

BILLING CODE 4910-13-P

DEPARTMENT OF TRANSPORTATION

Federal Aviation Administration

14 CFR Part 39

[Docket No. FAA-2006-23871; Directorate Identifier 2006-NE-01-AD; Amendment 39-14975; AD 2007-05-14]

RIN 2120-AA64

Airworthiness Directives; General Electric Company (GE) CF6-80C2 Turbofan Engines

AGENCY: Federal Aviation Administration (FAA), Department of Transportation (DOT).

ACTION: Final rule.

SUMMARY: The FAA is adopting a new airworthiness directive (AD) for GE CF6-80C2 series turbofan engines. This AD requires replacing certain installed part number (P/N) and serial number (SN) cast titanium weld-repaired forward engine mount platforms and cast titanium forward mount yokes, with a forged titanium or a non-welded cast titanium part. This AD results from the discovery of cracks, in a weld-repaired area on a forward engine mount platform and a forward engine mount yoke, found during a fluorescent penetrant inspection (FPI). These parts were weld-repaired during manufacture. We are issuing this AD to prevent cracks in the forward engine mount platform and forward engine mount yoke that could result in possible separation of the engine from the airplane.

DATES: This AD becomes effective April 9, 2007.

ADDRESSES: You can get the service information identified in this AD from General Electric Company via Lockheed Martin Technology Services, 10525 Chester Road, Suite C, Cincinnati, Ohio 45215, telephone (513) 672-8400, fax (513) 672-8422.

You may examine the AD docket on the Internet at <http://dms.dot.gov> or in Room PL-401 on the plaza level of the Nassif Building, 400 Seventh Street, SW., Washington, DC.

FOR FURTHER INFORMATION CONTACT:

James Lawrence, Aerospace Engineer, Engine Certification Office, FAA, Engine and Propeller Directorate, 12 New England Executive Park, Burlington, MA 01803; telephone (781) 238-7176; fax (781) 238-7199.

SUPPLEMENTARY INFORMATION: The FAA proposed to amend 14 CFR part 39 with a proposed AD. The proposed AD applies to GE CF6-80C2 series turbofan engines. We published the proposed AD in the **Federal Register** on December 13, 2006 (71 FR 74873). That action proposed to require replacing certain installed part number (P/N) and serial number (SN) cast titanium weld-repaired forward engine mount platforms and cast titanium forward mount yokes, with a forged titanium or a non-welded cast titanium part.

Examining the AD Docket

You may examine the docket that contains the AD, any comments received, and any final disposition in person at the Docket Management Facility between 9 a.m. and 5 p.m., Monday through Friday, except Federal holidays. The Docket Office (telephone (800) 647-5227) is located on the plaza level of the Department of Transportation Nassif Building at the street address stated in **ADDRESSES**.

Comments will be available in the AD docket shortly after the DMS receives them.

Comments

We provided the public the opportunity to participate in the development of this AD. We have considered the comments received.

Add Airbus A310 and MD-11 Airplanes to the Applicability

Commenters from Lufthansa Technik, KLM Royal Dutch Airlines, Airbus and Alitalia state that this AD is also applicable to the engines installed in the A310 and MD-11 airplanes. We agree. We inadvertently omitted the Airbus A310 and MD-11 airplanes from the Applicability section of the proposed rule. These airplanes are included in the Applicability section of the AD.

Reference GE Service Bulletins

Commenters from Lufthansa Technik, KLM Royal Dutch Airlines, Airbus and Alitalia also state that because the AD mandates requirements contained in GE Service Bulletins, CF6-80C2 S/B 72-1206 and CF6-80C2 S/B 72-1207, the FAA should reference the service bulletins in the final rule. We agree. The service bulletins' accomplishment instructions contain information such as applicable Aircraft Maintenance Manual sections that would clarify requirements of the AD. A reference to the service bulletins is included in the Related Information Section of the AD.

Location of Weld Repair

Representatives from Lufthansa Technik and KLM Royal Dutch Airlines note that paragraph (h) of the applicability section identifies a weld repair in a redundant area of the yoke, but Table 3 identifies the weld repair in a non-redundant area of the yoke. The FAA needs to correct this inconsistency in the final rule. We agree and have changed the heading of Table 3 to read, "Weld-Repaired Forward Engine Mount Yokes Requiring Replacement That Have a Weld Repair in a Redundant Area of the Yoke."

Conclusion

We have carefully reviewed the available data, including the comments received, and determined that air safety and the public interest require adopting the AD with the changes described previously. We have determined that these changes will neither increase the economic burden on any operator nor increase the scope of the AD.

Costs of Compliance

There are 25 engines in service that contain the substandard forward engine mount platforms and 59 engines in service that contain the substandard forward engine mount yokes. We estimate that this proposed AD would affect 84 CF6-80C2 engines installed on airplanes of U.S. registry. We estimate that it would take 34 work-hours per engine to replace the weld-repaired cast titanium forward engine mount platforms and the weld-repaired cast titanium forward engine mount yokes. The average labor rate is \$80 per work-hour. Required forward engine mount parts would cost about \$12,168 per engine. Required forward engine mount yoke parts would cost about \$39,560 per engine. Based on these figures, we estimate the total cost of the proposed AD to U.S. operators to be \$2,866,720.

Authority for This Rulemaking

Title 49 of the United States Code specifies the FAA's authority to issue rules on aviation safety. Subtitle I, section 106, describes the authority of the FAA Administrator. Subtitle VII, Aviation Programs, describes in more detail the scope of the Agency's authority.

We are issuing this rulemaking under the authority described in subtitle VII, part A, subpart III, section 44701, "General requirements." Under that section, Congress charges the FAA with promoting safe flight of civil aircraft in air commerce by prescribing regulations for practices, methods, and procedures the Administrator finds necessary for safety in air commerce. This regulation is within the scope of that authority because it addresses an unsafe condition that is likely to exist or develop on products identified in this rulemaking action.

Regulatory Findings

We have determined that this AD will not have federalism implications under Executive Order 13132. This AD will not have a substantial direct effect on the States, on the relationship between the national government and the States, or on the distribution of power and responsibilities among the various levels of government.

For the reasons discussed above, I certify that this AD:

- (1) Is not a "significant regulatory action" under Executive Order 12866;
- (2) Is not a "significant rule" under DOT Regulatory Policies and Procedures (44 FR 11034, February 26, 1979); and
- (3) Will not have a significant economic impact, positive or negative, on a substantial number of small entities

under the criteria of the Regulatory Flexibility Act.

We prepared a summary of the costs to comply with this AD and placed it in the AD Docket. You may get a copy of this summary at the address listed under ADDRESSES.

List of Subjects in 14 CFR Part 39

Air transportation, Aircraft, Aviation safety, Safety.

Adoption of the Amendment

■ Accordingly, under the authority delegated to me by the Administrator, the Federal Aviation Administration amends 14 CFR part 39 as follows:

PART 39—AIRWORTHINESS DIRECTIVES

- 1. The authority citation for part 39 continues to read as follows:

Authority: 49 U.S.C. 106(g), 40113, 44701.

§ 39.13 [Amended]

- 2. The FAA amends § 39.13 by adding the following new airworthiness directive:

2007-05-14 General Electric Company:

Amendment 39-14975. Docket No. FAA-2006-23871; Directorate Identifier 2006-NE-01-AD.

Effective Date

(a) This airworthiness directive (AD) becomes effective April 9, 2007.

Affected ADs

(b) None.

Applicability

(c) This AD applies to the following General Electric Company (GE) turbofan engines with cast titanium assembly engine mount platforms part numbers (P/Ns) 1292M13G06, 1301M28G08, 1459M70G07, and 1846M24G04 and cast titanium assembly engine mount yokes P/Ns 9383M43G14 and 9383M43G16 installed.

CF6-80C2A1
CF6-80C2A2
CF6-80C2A3
CF6-80C2A5
CF6-80C2A8
CF6-80C2A5F
CF6-80C2B1
CF6-80C2B2
CF6-80C2B4
CF6-80C2B6
CF6-80C2B1F
CF6-80C2B2F
CF6-80C2B4F
CF6-80C2B5F
CF6-80C2B6F
CF6-80C2B6FA
CF6-80C2B7F
CF6-80C2B8F
CF6-80C2D1F

These engines are installed on, but not limited to, Boeing 747, Boeing 767, MD-11 and Airbus A300-600 and A310 airplanes.

Unsafe Condition

(d) This AD results from the discovery of cracks in a forward engine mount platform and a forward engine mount yoke found during fluorescent penetrant inspection (FPI). We are issuing this AD to prevent cracks in the forward engine mount platform and forward engine mount yoke that could result in possible separation of the engine from the airplane.

Compliance

(e) You are responsible for having the actions required by this AD performed within the compliance times specified unless the actions have already been done.

P/N and SN Weld-Repaired Forward Engine Mount Platforms and Forward Engine Mount Yokes Requiring Replacement

(f) Table 1 of this AD lists the P/Ns and serial numbers (SNs) of the weld-repaired forward engine mount platforms that have a weld repair in a non-redundant area of the mount and must be replaced.

TABLE 1.—WELD-REPAIRED FORWARD ENGINE MOUNT PLATFORMS REQUIRING REPLACEMENT THAT HAVE A WELD REPAIR IN A NON-REDUNDANT AREA OF THE MOUNT

P/Ns	SNs
1292M13G06 or 1846M24G04	WACHH228 WACHH254 WACHH285 WACHH290 WACHH292 WACHH295 WACHH299 WACHH384 WACHH427 WACHH440 WACHH604
1301M28G08	WACAR292 WACAR354

(g) Table 2 of this AD lists the P/Ns and SNs of the weld-repaired forward engine mount platforms that have a weld repair in a redundant area of the mount. Because it is impossible to detect whether the mount is operating on the redundant feature, each of these mounts must be replaced. The compliance time for mounts in this category can be longer than for the mounts listed in Table 1 of this AD.

TABLE 2.—WELD-REPAIRED FORWARD ENGINE MOUNT PLATFORMS REQUIRING REPLACEMENT THAT HAVE A WELD REPAIR IN A REDUNDANT AREA OF THE MOUNT

P/Ns	SNs
1292M13G06 or 1846M24G04	WACHH173 WACHH189 WACHH274 WACHH278 WACHH314 WACHH325 WACHH486

TABLE 2.—WELD-REPAIRED FORWARD ENGINE MOUNT PLATFORMS REQUIRING REPLACEMENT THAT HAVE A WELD REPAIR IN A REDUNDANT AREA OF THE MOUNT—Continued

P/Ns	SNs
1301M28G08	WACAR294 WACAR304 WACAR353 WACAR372
1459M70G07	MTXT1282

(h) Table 3 of this AD lists the P/Ns and SNs of the weld-repaired forward engine mount yokes that have a weld repair in a redundant area of the yoke. Because it is impossible to detect whether the mount yoke is operating on the redundant feature, each of these mount yokes must be replaced. The compliance time for mounts in this category can be longer than for the mounts listed in Table 1 of this AD.

TABLE 3.—WELD-REPAIRED FORWARD ENGINE MOUNT YOKES REQUIRING REPLACEMENT THAT HAVE A WELD REPAIR IN A REDUNDANT AREA OF THE YOKE

P/Ns	SNs
9383M43G14	WACV0388 WACV0394 WACV0405 WACV0406 WACV0477 WACV0498 WACV0529 WACV0556 WACV0579 WACV0581 WACV0582 WACV0600 WACV0605 WACV0617 WACV0625 WACV0627 WACV0633 WACV0645 WACV0683 WACV0703 WACV0733 WACV0737 WACV0759 WACV0775 WACV0791 WACV0799 WACV0875 WACV0883 WACV0885 WACV0909 WACV1097 WACV1615 WACV1713 WACV1753 WACV1797 WACV1867 WACV1987 WACV2131 WACV2159 WACV2185 WACV2343

TABLE 3.—WELD-REPAIRED FORWARD ENGINE MOUNT YOKES REQUIRING REPLACEMENT THAT HAVE A WELD REPAIR IN A REDUNDANT AREA OF THE YOKE—Continued

P/Ns	SNs
9383M43G16	WACV2511 WACV2695 WACV2707 WACV2881 WACV2899 WACV0511 WACV0515 WACV0518 WACV0540 WACV0542 WACV0571 WACV0689 WACV0721 WACV0727 WACV0730 WACV0786 WACV0816 WACV0954

(i) GE advises that forward engine mount platform, P/Ns 1292M13G06 and 1846M24G04, are the same, except that P/N 1846M24G04 incorporates a previously approved field rework. This rework allows the thrust pin hole in the forward engine mount platform to be bored out to accept installation of an oversized thrust pin. GE cannot identify which SN goes with which P/N, but all SNs are affected.

Welded Cast Titanium Forward Engine Mount Platform and Forward Engine Mount Yoke Removal

(j) If the P/N and SN of the forward engine mount platform listed in Table 1 and Table 2 and the forward engine mount yoke listed in Table 3 of this AD are not installed on the engine, no further action is necessary.

(k) If the P/N and SN of the forward engine mount platform listed in Table 1 of this AD is installed on the engine:

(1) Remove the forward engine mount platform from the engine within 500 cycles or 6 months, after the effective date of this AD, whichever occurs first.

(2) Information for removal of the forward engine mount platform from the engine can be found in the CF6–80C2 Engine Manual, 72–00–01, Disassembly.

(l) If the P/N and SN of the forward engine mount platform listed in Table 2 of this AD is installed on the engine:

(1) Remove the forward engine mount platform at the next shop visit, or within 4,800 cycles after the effective date of this AD, whichever occurs first.

(2) Information for removal of the forward engine mount yoke can be found in the CF6–80C2 Engine Manual, 72–00–01, Disassembly.

(m) If the P/N and SN of the forward engine mount yoke listed in Table 3 of this AD is installed on the engine:

(1) Remove the forward engine mount yoke at the next shop visit, or within 4,800 cycles after the effective date of this AD, whichever occurs first.

(2) Information for removal of the forward engine mount yoke can be found in the CF6-80C2 Engine Manual, 72-00-01, Disassembly.

(n) Replace the affected forward engine mount platform and or the affected forward engine mount yoke with a non-weld-repaired

cast titanium forward engine mount platform and or the forward engine mount yoke or a forged titanium forward engine mount platform or a forged titanium forward engine mount yoke.

(o) Information for installing the forward engine mount platform and forward engine

mount yoke can be found in the CF6-80C2 Engine Manual, 72-00-01, Assembly.

(p) Location of the forward engine mount platform and forward engine mount yoke and SN are illustrated in the following Figure 1.

BILLING CODE 4910-13-P

ENGINE - Forward Mount Assembly (71-00-00) - Cast Assembly Engine Mount Platform and Cast Assembly Engine Mount Yoke Replacement

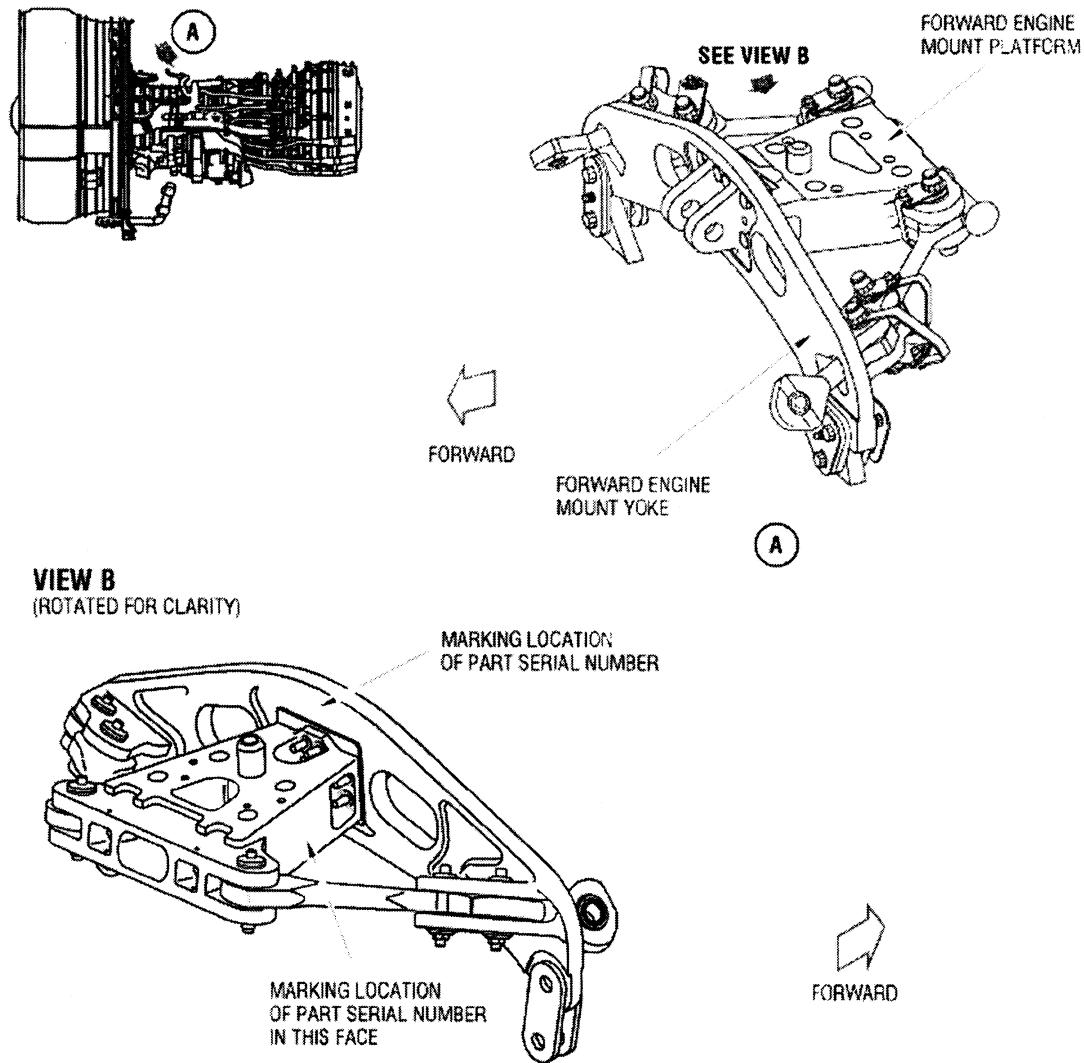

1243466-00

Location of Forward Engine Mount Platform and Forward Engine Mount Yoke
Figure 1

(q) After the effective date of this AD, do not install a weld-repaired, cast forward engine mount platform or a weld-repaired, cast forward engine mount yoke in any engine.

Alternative Methods of Compliance

(r) The Manager, Engine Certification Office, has the authority to approve alternative methods of compliance for this AD if requested using the procedures found in 14 CFR 39.19.

Related Information

(s) Contact James Lawrence, Aerospace Engineer, Engine Certification Office, FAA, Engine and Propeller Directorate, 12 New England Executive Park, Burlington, MA 01803; telephone (781) 238-7176; fax (781)

238–7199 for more information about this AD.

(t) General Electric Company Service Bulletins CF6–80C2 S/B 72–1206, dated December 23, 2005, and CF6–80C2 S/B 72–1207, Revision 01, dated July 05, 2006, pertain to the subject of this AD.

Issued in Burlington, Massachusetts, on February 27, 2007.

Peter A. White,

Acting Manager, Engine and Propeller Directorate, Aircraft Certification Service.

[FR Doc. 07–986 Filed 3–2–07; 8:45 am]

BILLING CODE 4910–13–P

DEPARTMENT OF TRANSPORTATION

Federal Aviation Administration

14 CFR Part 39

[Docket No. FAA–2006–26378; Directorate Identifier 2006–NM–230–AD; Amendment 39–14972; AD 2007–05–11]

RIN 2120–AA64

Airworthiness Directives; Bombardier Model CL–600–2B16 (CL–604) Airplanes and Model CL–600–2B19 (Regional Jet Series 100 & 440) Airplanes

AGENCY: Federal Aviation Administration (FAA), Department of Transportation (DOT).

ACTION: Final rule; request for comments.

SUMMARY: The FAA is superseding two existing airworthiness directives (ADs), that apply to certain Bombardier Model CL–600–2B16 (CL–604) airplanes and Model CL–600–2B19 (Regional Jet Series 100 & 440) airplanes. These models may be referred to by their marketing designations as RJ100, RJ200, RJ440, CRJ100, CRJ200, CRJ440, and CL–65. One existing AD requires replacing the horizontal stabilizer trim control unit (HSTCU) with a new HSTCU. The other existing AD requires revising the airplane flight manual (AFM) to advise the flightcrew of procedures to follow in the event of stabilizer trim runaway, and in the event of MACH TRIM, STAB TRIM, and horizontal stabilizer trim malfunctions; and revising the AFM to require a review of the location of certain circuit breakers. That AD also requires doing a functional check of the stabilizer trim system and installing circuit breaker identification collars, and provides an optional terminating action. This new AD requires the previously optional terminating action and requires further revisions to the AFM. This AD also requires the removal of certain AFM revisions. This AD results from reports

of trim problems including uncommanded trim, trim in the opposite direction to that selected, loss of trim position indication and, in one case, potential loss of trim disconnect capability. We are issuing this AD to prevent these events, which could result in conditions that vary from reduced controllability of the airplane to loss of control of the airplane.

DATES: This AD becomes effective March 20, 2007.

The Director of the Federal Register approved the incorporation by reference of certain publications listed in the AD as of March 20, 2007.

On November 14, 2006 (71 FR 63219, October 30, 2006), the Director of the Federal Register approved the incorporation by reference of certain other publications.

On July 30, 1998 (63 FR 34574, June 25, 1998), the Director of the Federal Register approved the incorporation by reference of a certain other publication.

We must receive any comments on this AD by April 4, 2007.

ADDRESSES: Use one of the following addresses to submit comments on this AD.

- *DOT Docket Web site:* Go to <http://dms.dot.gov> and follow the instructions for sending your comments electronically.

- *Government-wide rulemaking Web site:* Go to <http://www.regulations.gov> and follow the instructions for sending your comments electronically.

- *Mail:* Docket Management Facility, U.S. Department of Transportation, 400 Seventh Street, SW., Nassif Building, Room PL–401, Washington, DC 20590.

- *Fax:* (202) 493–2251.

- *Hand Delivery:* Room PL–401 on the plaza level of the Nassif Building, 400 Seventh Street, SW., Washington, DC, between 9 a.m. and 5 p.m., Monday through Friday, except Federal holidays.

Contact Bombardier, Inc., Canadair, Aerospace Group, P.O. Box 6087, Station Centre-ville, Montreal, Quebec H3C 3G9, Canada, for service information identified in this AD.

You may examine the contents of the AD docket on the Internet at <http://dms.dot.gov>, or in person at the Docket Management Facility, U.S. Department of Transportation, 400 Seventh Street, SW., Room PL–401, on the plaza level of the Nassif Building, Washington, DC. This docket number is FAA–2006–26378; the directorate identifier for this docket is 2006–NM–230–AD.

FOR FURTHER INFORMATION CONTACT:

Daniel Parrillo, Aerospace Engineer, Systems and Flight Test Branch, ANE–172, FAA, New York Aircraft Certification Office, 1600 Stewart

Avenue, Suite 410, Westbury, New York 11590; telephone (516) 228–7305; fax (516) 794–5531.

SUPPLEMENTARY INFORMATION:

Discussion

On October 13, 2006, the FAA issued a supplemental notice of proposed rulemaking (NPRM) to amend 14 CFR part 39 to include an AD that supersedes AD 2006–22–06, amendment 39–14803 (71 FR 63219, October 30, 2006). The existing AD applies to certain Bombardier Model CL–600–2B16 (CL–604) airplanes and Model CL–600–2B19 (Regional Jet Series 100 & 440) airplanes. That supplemental NPRM was published in the **Federal Register** on December 28, 2006 (71 FR 78096). That supplemental NPRM proposed to retain the requirements of AD 2006–22–06 and to require the previously optional terminating action (installation of a new horizontal stabilizer trim control unit (HSTCU)). That supplemental NPRM also proposed to require, for certain airplanes, re-inserting the applicable temporary revisions of the Emergency and Abnormal Procedures sections of the airplane flight manual (AFM) under certain conditions.

Actions Since Supplemental NPRM Was Issued

Since we issued that supplemental NPRM, Bombardier has issued new temporary revisions (TRs) to the AFMs as described in a comment submitted by the National Transportation Safety Board (NTSB) (see “Request to Revise AFM Procedures” paragraph below). In the comment, the NTSB presents data to indicate that changes to the AFMs are necessary to address the identified unsafe condition. We have coordinated with Transport Canada Civil Aviation (TCCA) on this issue and concur that changes to the AFMs are necessary. In consideration of these new data, we have determined that the AFMs must be revised to include the new TRs within 14 days after the effective date of this AD.

The FAA finds that, with respect to this additional requirement, since a situation exists that requires immediate adoption of this requirement, notice and time for prior public comment hereon are impracticable, and good cause exists for making this amendment effective in less than 30 days. Therefore, this AD will include the requirements specified in the supplemental NPRM (except the proposed requirement to re-insert TRs to the AFMs), as well as the certain new requirements discussed below. The new requirements include revising the AFMs to include the new TRs. In addition, we