

	Field name	FDIC field description	Questions/comments for the industry
11 .....	CS_Suffix .....	Customer Suffix: The suffix of the individual/ personal customer— <i>i.e.</i> Jr., Sr., III, etc.	How are business customers reflected in your customer records? Are there multiple name/address fields?
12 .....	CS_Comp_Name .....	Customer Company Name: The company name of the business customer.	
13 .....	CS_Address_1 .....	Address Line 1: Two lines (Fields 13 & 14) are provided to enter the street, PO Box, suite number, etc. of the address.	
14 .....	CS_Address_2 .....	Address Line 2: Additional address field.	
15 .....	CS_City .....	City: Enter the city associated with the mailing address of the customer.	
16 .....	CS_State .....	State: Enter the state abbreviation associated with the mailing address of the customer.	
17 .....	CS_ZIP .....	ZIP: This field allows for the ZIP+ 4 Code associated with the mailing address of the customer.	
18 .....	CS_Country .....	Country: This field should identify the country associated with the mailing address. Provide the name of the country or the standard country code.	
19 .....	CS_Birth_Dt .....	Customer Birth Date: The birth date on record for the customer. Must be entered in MMDDYYYY format.	
20 .....	CS_Telephone .....	Customer Telephone Number: The telephone number on record for the customer.	
21 .....	CS_Email .....	Customer Email Address: The e-mail address on record for the customer.	

\* \* \* \* \*

By order of the Board of Directors.  
Dated at Washington, DC, this 5th day of  
December, 2006.

Federal Deposit Insurance Corporation.

**Robert E. Feldman,**

*Executive Secretary.*

[FR Doc. E6-21143 Filed 12-12-06; 8:45 am]

BILLING CODE 6714-01-P

## DEPARTMENT OF TRANSPORTATION

### Federal Aviation Administration

#### 14 CFR Part 39

[Docket No. FAA-2006-23871; Directorate  
Identifier 2006-NE-01-AD]

RIN 2120-AA64

#### Airworthiness Directives; General Electric Company (GE) CF6-80C2 Turbofan Engines

**AGENCY:** Federal Aviation  
Administration (FAA), Department of  
Transportation (DOT).

**ACTION:** Notice of proposed rulemaking  
(NPRM).

**SUMMARY:** The FAA proposes to adopt a new airworthiness directive (AD) for GE CF6-80C2 series turbofan engines. This proposed AD would require replacing certain installed part number (P/N) and serial number (SN) cast titanium weld-repaired forward engine mount platforms and cast titanium forward mount yokes, with a forged titanium or a non-welded cast titanium part. This proposed AD results from the discovery

of cracks, in a weld-repaired area on a forward engine mount platform and a forward engine mount yoke, found during a fluorescent penetrant inspection (FPI). These parts were weld-repaired during manufacture. We are proposing this AD to prevent cracks in the forward engine mount platform and forward engine mount yoke that could result in possible separation of the engine from the airplane.

**DATES:** We must receive any comments on this proposed AD by January 12, 2007.

**ADDRESSES:** Use one of the following addresses to comment on this proposed AD.

- *DOT Docket Web site:* Go to <http://dms.dot.gov> and follow the instructions for sending your comments electronically.

- *Government-wide rulemaking Web site:* Go to <http://www.regulations.gov> and follow the instructions for sending your comments electronically.

- *Mail:* Docket Management Facility; U.S. Department of Transportation, 400 Seventh Street, SW., Nassif Building, Room PL-401, Washington, DC 20590-0001.

- *Fax:* (202) 493-2251.

- *Hand Delivery:* Room PL-401 on the plaza level of the Nassif Building, 400 Seventh Street, SW., Washington, DC, between 9 a.m. and 5 p.m., Monday through Friday, except Federal holidays.

You may examine the comments on this proposed AD in the AD docket on the Internet at <http://dms.dot.gov>.

**FOR FURTHER INFORMATION CONTACT:**  
James Lawrence, Aerospace Engineer,

Engine Certification Office, FAA, Engine and Propeller Directorate, 12 New England Executive Park, Burlington, MA 01803; telephone (781) 238-7176; fax (781) 238-7199.

#### SUPPLEMENTARY INFORMATION:

##### Comments Invited

We invite you to send us any written relevant data, views, or arguments regarding this proposal. Send your comments to an address listed under **ADDRESSES**. Include "Docket No. FAA-2006-23871; Directorate Identifier 2006-NE-01-AD" in the subject line of your comments. We specifically invite comments on the overall regulatory, economic, environmental, and energy aspects of the proposed AD. We will consider all comments received by the closing date and may amend the proposed AD in light of those comments.

We will post all comments we receive, without change, to <http://dms.dot.gov>, including any personal information you provide. We will also post a report summarizing each substantive verbal contact with FAA personnel concerning this proposed AD. Using the search function of the DOT Web site, anyone can find and read the comments in any of our dockets, including the name of the individual who sent the comment (or signed the comment on behalf of an association, business, labor union, etc.). You may review the DOT's complete Privacy Act Statement in the **Federal Register** published on April 11, 2000 (65 FR 19477-78) or you may visit <http://dms.dot.gov>.

**Examining the AD Docket**

You may examine the docket that contains the proposal, any comments received, and any final disposition in person at the DOT Docket Office between 9 a.m. and 5 p.m., Monday through Friday, except Federal holidays. The Docket Office (telephone (800) 647-5227) is located on the plaza level of the Department of Transportation Nassif Building at the street address stated in **ADDRESSES**. Comments will be available in the AD docket shortly after the Docket Management Facility receives them.

**Discussion**

During an FPI inspection of the forward engine mount platform and forward engine mount yoke, an air carrier found crack indications in the forward engine mount platform and yoke, and reported the findings to GE. An audit of GE's manufacturing records revealed 25 cast titanium forward engine mount platforms, including the one found cracked, and 59 cast titanium forward engine mount yokes, had been weld-repaired at manufacture in either the pylon thrust pin hole or in the pylon attach bolt-hole region. Therefore, 25 cast titanium forward engine mount platforms and 59 cast titanium forward engine mount yokes would be affected by this proposed AD. Although the weld repairs were an approved GE practice at the time, it has since been determined that the welding results in cracking in critical areas of the forward engine mount platforms and yokes. This condition, if not corrected, could result in possible separation of the engine from the airplane.

**FAA's Determination and Requirements of the Proposed AD**

We have evaluated all pertinent information and identified an unsafe condition that is likely to exist or develop on other products of this same type design. We are proposing this AD, which would require replacing certain installed P/N and SN cast titanium weld-repaired forward engine mount platforms and cast titanium forward engine mount yokes with a forged titanium or a non-welded cast titanium part.

**Costs of Compliance**

There are 25 engines in service that contain the substandard forward engine mount platforms and 59 engines in service that contain the substandard forward engine mount yokes. We estimate that this proposed AD would affect 84 CF6-80C2 engines installed on airplanes of U.S. registry. We estimate that it would take 34 work-hours per engine to replace the weld-repaired cast titanium forward engine mount platforms and the weld-repaired cast titanium forward engine mount yokes. The average labor rate is \$80 per work-hour. Required forward engine mount parts would cost about \$12,168 per engine. Required forward engine mount yoke parts would cost about \$39,560 per engine. Based on these figures, we estimate the total cost of the proposed AD to U.S. operators to be \$2,866,720.

**Authority for This Rulemaking**

Title 49 of the United States Code specifies the FAA's authority to issue rules on aviation safety. Subtitle I, Section 106, describes the authority of the FAA Administrator. Subtitle VII, Aviation Programs, describes in more detail the scope of the Agency's authority.

We are issuing this rulemaking under the authority described in Subtitle VII, Part A, Subpart III, Section 44701, "General requirements." Under that section, Congress charges the FAA with promoting safe flight of civil aircraft in air commerce by prescribing regulations for practices, methods, and procedures the Administrator finds necessary for safety in air commerce. This regulation is within the scope of that authority because it addresses an unsafe condition that is likely to exist or develop on products identified in this rulemaking action.

**Regulatory Findings**

We have determined that this proposed AD would not have federalism implications under Executive Order 13132. This proposed AD would not have a substantial direct effect on the States, on the relationship between the national Government and the States, or on the distribution of power and responsibilities among the various levels of government.

For the reasons discussed above, I certify that the proposed regulation:

1. Is not a "significant regulatory action" under Executive Order 12866;
2. Is not a "significant rule" under the DOT Regulatory Policies and Procedures (44 FR 11034, February 26, 1979); and
3. Would not have a significant economic impact, positive or negative, on a substantial number of small entities under the criteria of the Regulatory Flexibility Act.

We prepared a regulatory evaluation of the estimated costs to comply with this proposed AD. See the **ADDRESSES** section for a location to examine the regulatory evaluation.

**List of Subjects in 14 CFR Part 39**

Air transportation, Aircraft, Aviation safety, Safety.

**The Proposed Amendment**

Under the authority delegated to me by the Administrator, the Federal Aviation Administration proposes to amend 14 CFR part 39 as follows:

**PART 39—AIRWORTHINESS DIRECTIVES**

1. The authority citation for part 39 continues to read as follows:

**Authority:** 49 U.S.C. 106(g), 40113, 44701.

**§ 39.13 [Amended]**

2. The FAA amends § 39.13 by adding the following new airworthiness directive:

**General Electric Company:** Docket No. FAA-2006-23871; Directorate Identifier 2006-NE-01-AD.

**Comments Due Date**

(a) The Federal Aviation Administration (FAA) must receive comments on this airworthiness directive (AD) action by January 12, 2007.

**Affected ADs**

- (b) None.

**Applicability**

(c) This AD applies to the following General Electric Company (GE) turbofan engines with cast titanium assembly engine mount platforms part numbers (P/Ns) 1292M13G06, 1301M28G08, 1459M70G07, and 1846M24G04 and cast titanium assembly engine mount yokes P/Ns 9383M43G14 and 9383M43G16 installed.

CF6-80C2A1 .....	CF6-80C2A8 .....	CF6-80C2B4 .....	CF6-80C2B4F .....
CF6-80C2A2 .....	CF6-80C2A5F .....	CF6-80C2B6 .....	CF6-80C2B5F .....
CF6-80C2A3 .....	CF6-80C2B1 .....	CF6-80C2B1F .....	CF6-80C2B6F .....
CF6-80C2A5 .....	CF6-80C2B2 .....	CF6-80C2B2F .....	CF6-80C2B6FA .....

These engines are installed on, but not limited to, Boeing 747, Boeing 767, and Airbus A300-600 airplanes.

**Unsafe Condition**

(d) This AD results from the discovery of cracks in a forward engine mount platform and a forward engine mount yoke found during fluorescent penetrant inspection (FPI). We are issuing this AD to prevent cracks in the forward engine mount platform and forward engine mount yoke that could result in possible separation of the engine from the airplane.

**Compliance**

(e) You are responsible for having the actions required by this AD performed within the compliance times specified unless the actions have already been done.

**P/N and SN Weld-Repaired Forward Engine Mount Platforms and Forward Engine Mount Yokes Requiring Replacement**

(f) Table 1 of this AD lists the P/Ns and serial numbers (SNs) of the weld-repaired forward engine mount platforms that have a weld repair in a non-redundant area of the mount and must be replaced.

**TABLE 1.—WELD-REPAIRED FORWARD ENGINE MOUNT PLATFORMS REQUIRING REPLACEMENT THAT HAVE A WELD REPAIR IN A NON-REDUNDANT AREA OF THE MOUNT.**

P/Ns	SNs
1292M13G06 or 1846M24G04	WACHH228 WACHH254 WACHH285 WACHH290 WACHH292 WACHH295 WACHH299 WACHH384 WACHH427 WACHH440 WACHH604
1301M28G08 .....	WACAR292 WACAR354

(g) Table 2 of this AD lists the P/Ns and SNs of the weld-repaired forward engine mount platforms that have a weld repair in a redundant area of the mount. Because it is impossible to detect whether the mount is operating on the redundant feature, each of these mounts must be replaced. The compliance time for mounts in this category can be longer than for the mounts listed in Table 1 of this AD.

**TABLE 2.—WELD-REPAIRED FORWARD ENGINE MOUNT PLATFORMS REQUIRING REPLACEMENT THAT HAVE A WELD REPAIR IN A REDUNDANT AREA OF THE MOUNT**

P/Ns	SNs
1292M13G06 or 1846M24G04	WACHH173 WACHH189 WACHH274

**TABLE 2.—WELD-REPAIRED FORWARD ENGINE MOUNT PLATFORMS REQUIRING REPLACEMENT THAT HAVE A WELD REPAIR IN A REDUNDANT AREA OF THE MOUNT—Continued**

P/Ns	SNs
1301M28G08 .....	WACHH278 WACHH314 WACHH325 WACHH486 WACAR294 WACAR304 WACAR353 WACAR372
1459M70G07 .....	MTXT1282

(h) Table 3 of this AD lists the P/Ns and SNs of the weld-repaired forward engine mount yokes that have a weld repair in a redundant area of the yoke. Because it is impossible to detect whether the mount yoke is operating on the redundant feature, each of these mount yokes must be replaced. The compliance time for mounts in this category can be longer than for the mounts listed in Table 1 of this AD.

**TABLE 3.—WELD-REPAIRED FORWARD ENGINE MOUNT YOKES REQUIRING REPLACEMENT THAT HAVE A WELD REPAIR IN A NON-REDUNDANT AREA OF THE YOKE**

P/Ns	SNs
9383M43G14 .....	WACV0388 WACV0394 WACV0405 WACV0406 WACV0477 WACV0498 WACV0529 WACV0556 WACV0579 WACV0581 WACV0582 WACV0600 WACV0605 WACV0617 WACV0625 WACV0627 WACV0633 WACV0645 WACV0683 WACV0703 WACV0733 WACV0737 WACV0759 WACV0775 WACV0791 WACV0799 WACV0875 WACV0883 WACV0885 WACV0909 WACV1097 WACV1615 WACV1713 WACV1753 WACV1797 WACV1867 WACV1987

**TABLE 3.—WELD-REPAIRED FORWARD ENGINE MOUNT YOKES REQUIRING REPLACEMENT THAT HAVE A WELD REPAIR IN A NON-REDUNDANT AREA OF THE YOKE—Continued**

P/Ns	SNs
9383M43G16 .....	WACV2131 WACV2159 WACV2185 WACV2343 WACV2511 WACV2695 WACV2707 WACV2881 WACV2899 WACV0511 WACV0515 WACV0518 WACV0540 WACV0542 WACV0571 WACV0689 WACV0721 WACV0727 WACV0730 WACV0786 WACV0816 WACV0954

(i) GE advises that forward engine mount platform, P/Ns 1292M13G06 and 1846M24G04, are the same, except that P/N 1846M24G04 incorporates a previously approved field rework. This rework allows the thrust pin hole in the forward engine mount platform to be bored out to accept installation of an oversized thrust pin. GE cannot identify which SN goes with which P/N, but all SNs are affected.

**Welded Cast Titanium Forward Engine Mount Platform and Forward Engine Mount Yoke Removal**

(j) If the P/N and SN of the forward engine mount platform listed in Table 1 and Table 2 and the forward engine mount yoke listed in Table 3 of this AD are not installed on the engine, no further action is necessary.

(k) If the P/N and SN of the forward engine mount platform listed in Table 1 of this AD is installed on the engine:

(1) Remove the forward engine mount platform from the engine within 500 cycles or 6 months, after the effective date of this AD, whichever occurs first.

(2) Information for removal of the forward engine mount platform from the engine can be found in the CF6-80C2 Engine Manual, 72-00-01, Disassembly.

(l) If the P/N and SN of the forward engine mount platform listed in Table 2 of this AD is installed on the engine:

(1) Remove the forward engine mount platform at the next shop visit, or within 4,800 cycles after the effective date of this AD, whichever occurs first.

(2) Information for removal of the forward engine mount yoke can be found in the CF6-80C2 Engine Manual, 72-00-01, Disassembly.

(m) If the P/N and SN of the forward engine mount yoke listed in Table 3 of this AD is installed on the engine:

(1) Remove the forward engine mount yoke at the next shop visit, or within 4,800 cycles after the effective date of this AD, whichever occurs first.

(2) Information for removal of the forward engine mount yoke can be found in the CF6-80C2 Engine Manual, 72-00-01, Disassembly.

(n) Replace the affected forward engine mount platform and or the affected forward engine mount yoke with a non-weld-repaired cast titanium forward engine mount platform and or the forward engine mount yoke or a forged titanium forward engine mount platform or a forged titanium forward engine mount yoke.

(o) Information for installing the forward engine mount platform and forward engine mount yoke can be found in the CF6-80C2 Engine Manual, 72-00-01, Assembly.

(p) Location of the forward engine mount platform and forward engine mount yoke and SN are illustrated in the following Figure 1.

**BILLING CODE 4910-13-P**

ENGINE - Forward Mount Assembly (71-00-00) - Cast Assembly Engine Mount Platform and Cast Assembly Engine Mount Yoke Replacement

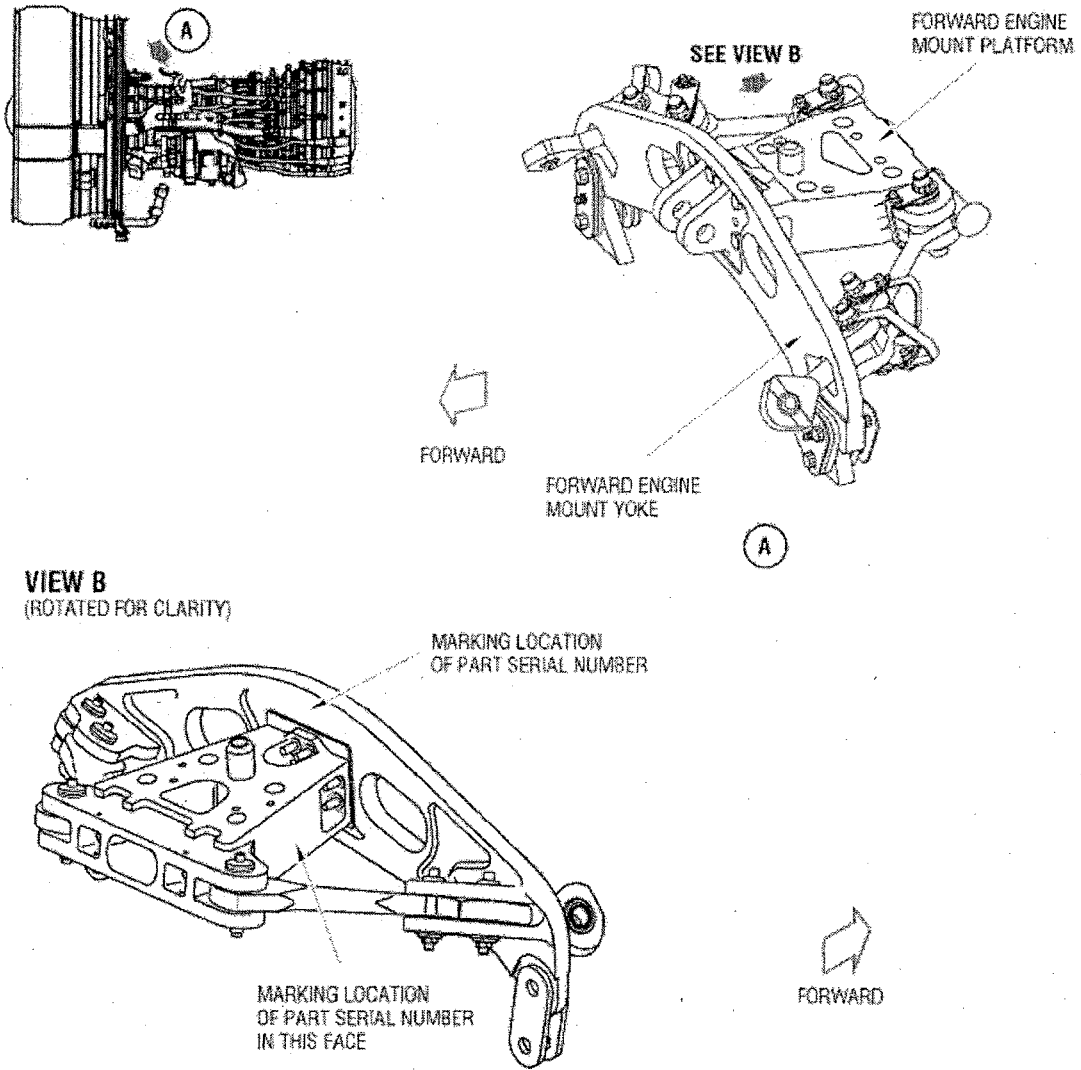

1243465-00

Location of Forward Engine Mount Platform and Forward Engine Mount Yoke  
Figure 1

cast forward engine mount yoke in any engine.

#### Alternative Methods of Compliance

(r) The Manager, Engine Certification Office, has the authority to approve alternative methods of compliance for this AD if requested using the procedures found in 14 CFR 39.19.

Issued in Burlington, Massachusetts, on December 7, 2006.

**Robert Ganley,**

*Acting Manager, Engine and Propeller Directorate, Aircraft Certification Service.*

[FR Doc. 06-9674 Filed 12-12-06; 8:45 am]

BILLING CODE 4910-13-P

## DEPARTMENT OF TRANSPORTATION

### Federal Aviation Administration

#### 14 CFR Part 39

[Docket No. FAA-2005-20856; Directorate Identifier 2004-NE-25-AD]

RIN 2120-AA64

#### Airworthiness Directives; MT-Propeller Entwicklung GmbH Propellers

**AGENCY:** Federal Aviation Administration (FAA), Department of Transportation (DOT).

**ACTION:** Notice of proposed rulemaking (NPRM).

**SUMMARY:** The FAA proposes to supersede an existing airworthiness directive (AD) for certain MT-Propeller Entwicklung GmbH variable pitch and fixed pitch propellers manufactured before 1995 which had not been overhauled since April 1994. That AD currently requires overhauling the propeller blades and performing initial and repetitive visual inspections of affected propeller blades. That AD also requires removing all propeller blades from service with damaged erosion sheath bonding or loose erosion sheaths and installing any missing or damaged polyurethane protective strips. This proposed AD would require the same actions. This proposed AD results from the need to clarify the population of affected propellers previously listed in AD 2006-05-05. We are proposing this AD to prevent erosion sheath separation leading to damage of the airplane.

**DATES:** We must receive any comments on this proposed AD by February 12, 2007.

**ADDRESSES:** Use one of the following addresses to comment on this proposed AD.

- DOT Docket Web site: Go to <http://dms.dot.gov> and follow the instructions for sending your comments electronically.

- Government-wide rulemaking Web site: Go to <http://www.regulations.gov> and follow the instructions for sending your comments electronically.

- Mail: Docket Management Facility; U.S. Department of Transportation, 400 Seventh Street, SW., Nassif Building, Room PL-401, Washington, DC 20590-0001.

- Fax: (202) 493-2251.

- Hand Delivery: Room PL-401 on the plaza level of the Nassif Building, 400 Seventh Street, SW., Washington, DC, between 9 a.m. and 5 p.m., Monday through Friday, except Federal holidays.

Contact MT-Propeller USA, Inc., 1180 Airport Terminal Drive, Deland, FL 32724; telephone (386) 736-7762, fax (386) 736-7696 or visit <http://www.mt-propeller.com> for the service information identified in this proposed AD.

#### FOR FURTHER INFORMATION CONTACT:

Frank Walsh, Aerospace Engineer, Boston Aircraft Certification Office, FAA, Engine and Propeller Directorate, 12 New England Executive Park, Burlington, MA 01803-5299; telephone (781) 238-7158, fax (781) 238-7170.

#### SUPPLEMENTARY INFORMATION:

##### Comments Invited

We invite you to send any written relevant data, views, or arguments regarding this proposal. Send your comments to an address listed under **ADDRESSES**. Include "Docket No. FAA-2005-20856; Directorate Identifier 2004-NE-25-AD" in the subject line of your comments. We specifically invite comments on the overall regulatory, economic, environmental, and energy aspects of the proposed AD. We will consider all comments received by the closing date and may amend the proposed AD in light of those comments.

We will post all comments we receive, without change, to <http://dms.dot.gov>, including any personal information you provide. We will also post a report summarizing each substantive verbal contact with FAA personnel concerning this proposed AD. Using the search function of the DMS Web site, anyone can find and read the comments in any of our dockets, including the name of the individual who sent the comment (or signed the comment on behalf of an association, business, labor union, etc.). You may review the DOT's complete Privacy Act Statement in the **Federal Register** published on April 11, 2000 (65 FR 19477-78) or you may visit <http://dms.dot.gov>.

#### Examining the AD Docket

You may examine the docket that contains the proposal, any comments received and any final disposition in person at the DMS Docket Office between 9 a.m. and 5 p.m., Monday through Friday, except Federal holidays. The Docket Office (telephone (800) 647-5227) is located on the plaza level of the Department of Transportation Nassif Building at the street address stated in **ADDRESSES**. Comments will be available in the AD docket shortly after the DMS receives them.

#### Discussion

On February 24, 2006, we issued AD 2006-05-05, Amendment 39-14502 (71 FR 11151, March 6, 2006). That AD requires overhaul of models MT, MTV-1, MTV-2, MTV-3, MTV-5, MTV-6, MTV-7, MTV-9, MTV-10, MTV-11, MTV-12, MTV-14, MTV-15, MTV-17, MTV-18, MTV-20, MTV-21, MTV-22, MTV-24, and MTV-25 propellers with serial numbers (SNs) below 95000, which had not been overhauled since April 1994, within 30 days after the effective date of the AD. That action also required performing initial and repetitive visual inspections of those propeller blades. That action also required removing all propeller blades from service with damaged erosion sheath bonding or loose erosion sheaths and to install any missing or damaged polyurethane protective strips. The European Aviation Safety Agency (EASA), which is the airworthiness authority for the European Union, notified us that an unsafe condition may exist on certain MT-Propeller Entwicklung GmbH propellers.

#### Actions Since AD 2006-05-05 Was Issued

Since AD 2006-05-05 was issued, MT-Propeller Entwicklung GmbH Propellers and EASA have clarified the population of affected propellers. AD 2006-05-05 described the affected propellers as variable pitch and fixed pitch propellers with serial numbers (SNs) below 95000. Because propellers with SNs starting with 00, 01, 02, 03, 04, 05, and 06, were manufactured in the years 2000, 2001, 2002, 2003, 2004, 2005, and 2006 respectively, some operators are confused as to whether their propeller SN is part of the affected population. For example, propeller SN 00246, manufactured in 2000, would appear to be part of the affected population because the number is below 95000. For clarification, we are proposing to identify the affected population as variable pitch and fixed pitch propellers manufactured before