

PART 39—AIRWORTHINESS DIRECTIVES

1. The authority citation for part 39 continues to read as follows:

Authority: 49 U.S.C. 106(g), 40113, 44701.

§ 39.13 [Amended]

2. The Federal Aviation Administration (FAA) amends § 39.13 by adding the following new airworthiness directive (AD):

Bombardier, Inc. (Formerly de Havilland, Inc.): Docket No. FAA-2006-26217; Directorate Identifier 2006-NM-209-AD.

Comments Due Date

(a) The FAA must receive comments on this AD action by December 4, 2006.

Affected ADs

(b) None.

Applicability

(c) This AD applies to certain Bombardier Model DHC-8-400 series airplanes, serial numbers 4001, 4003, 4004, 4006, and 4008 through 4126 inclusive, certificated in any category.

Unsafe Condition

(d) This AD results from data obtained from the manufacturer's fatigue testing. We are issuing this AD to detect and correct fatigue cracking of certain principal structural elements (PSEs), which could result in reduced structural integrity of the airplane.

Compliance

(e) You are responsible for having the actions required by this AD performed within the compliance times specified, unless the actions have already been done.

Note 1: This AD requires revisions to certain operator maintenance documents to include new inspections. Compliance with these inspections is required by 14 CFR 91.403(c). For airplanes that have been previously modified, altered, or repaired in the areas addressed by these inspections, the operator may not be able to accomplish the inspections described in the revisions. In this situation, to comply with 14 CFR 91.403(c), the operator must request approval for an alternative method of compliance according to paragraph (g) of this AD. The request should include a description of changes to the required inspections that will ensure the continued damage tolerance of the affected structure. The FAA has provided guidance for this determination in Advisory Circular (AC) 25-1529-1.

Maintenance Requirements Manual Revision

(f) Within 60 days after the effective date of this AD, revise the Airworthiness Limitations Items (ALI), Part 2, Section 2, of the Bombardier Q400 Dash 8 Maintenance Requirements Manual, PSM 1-84-7, by incorporating the information in Bombardier Temporary Revisions (TR) ALI-53, dated February 16, 2006, and ALI-54, dated March 27, 2006. Thereafter, except as provided in

paragraph (g) of this AD, no alternative structural inspection intervals may be approved for the fuselage and doors as specified in the TRs.

Note 2: The actions required by paragraph (f) of this AD may be done by inserting copies of TR ALI-53, dated February 16, 2006, and TR ALI-54, dated March 27, 2006; into the ALI, Part 2, Section 2, of the Bombardier Q400 Dash 8 Maintenance Requirements Manual, PSM 1-84-7. When TRs ALI-53 and ALI-54 have been included in the general revisions of the maintenance requirements manual, the general revisions may be inserted into the maintenance requirements manual, provided the relevant information in the general revision is identical to that in TRs ALI-53 and ALI-54.

Alternative Methods of Compliance (AMOCs)

(g)(1) The Manager, New York Aircraft Certification Office (ACO), FAA, has the authority to approve AMOCs for this AD, if requested in accordance with the procedures found in 14 CFR 39.19.

(2) Before using any AMOC approved in accordance with § 39.19 on any airplane to which the AMOC applies, notify the appropriate principal inspector in the FAA Flight Standards Certificate Holding District Office.

Related Information

(h) Canadian airworthiness directive CF-2006-10, dated May 12, 2006, also addresses the subject of this AD.

Issued in Renton, Washington, on October 25, 2006.

Kalene C. Yanamura,

Acting Manager, Transport Airplane Directorate, Aircraft Certification Service.

[FR Doc. E6-18461 Filed 11-1-06; 8:45 am]

BILLING CODE 4910-13-P

DEPARTMENT OF TRANSPORTATION

Federal Aviation Administration

14 CFR Part 39

[Docket No. FAA-2006-26219; Directorate Identifier 2004-SW-49-AD]

RIN 2120-AA64

Airworthiness Directives; Bell Helicopter Textron Model 204B, 205A, 205A-1, 205B, 210, 212, 412, 412CF, and 412EP Helicopters

AGENCY: Federal Aviation Administration, DOT.

ACTION: Notice of proposed rulemaking (NPRM).

SUMMARY: This document proposes adopting a new airworthiness directive (AD) for Bell Helicopter Textron (Bell) Model 204B, 205A, 205A-1, 205B, 210, 212, 412, 412CF, and 412EP helicopters. The AD would require certain checks and inspections of each tail rotor blade

assembly (T/R blade) at specified intervals and repairing or replacing, as applicable, any unairworthy T/R blade. This proposal is prompted by eight reports of T/R blade failures. The actions specified by the proposed AD are intended to prevent failure of a T/R blade and subsequent loss of control of the helicopter.

DATES: Comments must be received on or before January 2, 2007.

ADDRESSES: Use one of the following addresses to submit comments on this proposed AD:

- *DOT Docket Web site:* Go to <http://dms.dot.gov> and follow the instructions for sending your comments electronically;

- *Government-wide rulemaking Web site:* Go to <http://www.regulations.gov> and follow the instructions for sending your comments electronically;

- *Mail:* Docket Management Facility, U.S. Department of Transportation, 400 Seventh Street, SW., Nassif Building, Room PL-401, Washington, DC 20590;

- *Fax:* 202-493-2251; or

- *Hand Delivery:* Room PL-401 on the plaza level of the Nassif Building, 400 Seventh Street, SW., Washington, DC, between 9 a.m. and 5 p.m., Monday through Friday, except Federal holidays.

You may get the service information identified in this proposed AD from Bell Helicopter Textron, Inc., P.O. Box 482, Fort Worth, Texas 76101, telephone (817) 280-3391, fax (817) 280-6466.

You may examine the comments to this proposed AD in the AD docket on the Internet at <http://dms.dot.gov>.

FOR FURTHER INFORMATION CONTACT: Michael Kohner, Aviation Safety Engineer, FAA, Rotorcraft Directorate, Rotorcraft Certification Office, Fort Worth, Texas 76193-0170, telephone (817) 222-5447, fax (817) 222-5783.

SUPPLEMENTARY INFORMATION:

Comments Invited

We invite you to submit any written data, views, or arguments regarding this proposed AD. Send your comments to the address listed under the caption **ADDRESSES**. Include the docket number "FAA-2006-26219, Directorate Identifier 2004-SW-49-AD" at the beginning of your comments. We specifically invite comments on the overall regulatory, economic, environmental, and energy aspects of the proposed AD. We will consider all comments received by the closing date and may amend the proposed AD in light of those comments.

We will post all comments we receive, without change, to <http://dms.dot.gov>, including any personal information you provide. We will also

post a report summarizing each substantive verbal contact with FAA personnel concerning this proposed rulemaking. Using the search function of our docket Web site, you can find and read the comments to any of our dockets, including the name of the individual who sent or signed the comment. You may review the DOT's complete Privacy Act Statement in the **Federal Register** published on April 11, 2000 (65 FR 19477-78) or you may visit <http://dms.dot.gov>.

Examining the Docket

You may examine the docket that contains the proposed AD, any comments, and other information in person at the Docket Management System (DMS) Docket Office between 9 a.m. and 5 p.m., Monday through Friday, except Federal holidays. The Docket Office (telephone 1-800-647-5227) is located at the plaza level of the Department of Transportation NASSIF Building in Room PL-401 at 400

Seventh Street, SW., Washington, DC. Comments will be available in the AD docket shortly after the DMS receives them.

Discussion

There have been eight reported failures due to fatigue cracking of T/R blades installed on Bell Model 212 and 412 helicopters (three failures on the Bell Model 212 and five failures on the Bell Model 412) with a blade assembly part number (P/N) 212-010-750-009, -105, and -107. Six of the cracks initiated between blade stations 30 to 33.5; one crack initiated at blade station 21.9; and one crack initiated at blade station 27.6. Three of the failures were in-flight and the T/R blades were installed on Bell Model 412 series helicopters. In one of the in-flight failures, the T/R blade failed due to a fatigue crack that initiated in the blade skin from a nick .060 inches long by .008 inches deep. The initial damage was above the maximum allowable

damage limit for the blade skin provided in the maintenance manual. That failed blade had accumulated 1,478 hours time-in-service (TIS). In another in-flight failure, a section of the T/R blade separated from the helicopter during cruise flight at 5,500 feet. The helicopter was reported to have violently turned down and to the left. The helicopter "leveled out" at approximately 1,000 feet before setting down in the water. The blade failed due to a cracked stainless steel leading edge spar that originated from a corrosion pit .001 inches deep. The corrosion area extended .003 inches along the surface of the origin location.

That blade had accumulated 4,643 hours TIS. In the third in-flight failure, sanding on the spar and chem-milling was found during a post-accident investigation. The crack had initiated at blade station 21.9 and the blade had accumulated 1,232 hours TIS. Also, the following blades were found cracked during an inspection:

Model	Year	P/N 212-010-750-	Hours TIS	Blade station (in.)	Crack length (in)	Initial damage part and type	Initial damage size
212	1973	-009	3,224	32.2	6.5	Skin—Corrosion030 in. wide.
212	1985	-009	279	31.5	13.0	Spar—Manufacturing Notch.	.090 in. wide.
212	1991	-105	423	30.8	8.0	Skin—Non Sharp Dent75 in. long.
412	1990	-009	3,876	27.6	8.0	Skin—Corrosion	Unknown.
412	1996	-105	1,235	30.0	8.3	Skin—Scratch45 in. long by .005 in. deep.

A preliminary investigation after one of the in-flight blade failures indicated that the operator (Canadian Department of Defense) was not using any specific inspection methods to detect small-scale damage on the T/R blades as required by the maintenance manual. A daily inspection was being conducted from the ground with the tail rotor mounted over 10 feet off of the ground. Inquiries to other Model 212 and 412 helicopter operators indicate that some of them are not accomplishing adequate inspections either. The accident investigation team concluded that without a detailed visual inspection, the probability of detection is extremely low for the kind of damage and fatigue crack that results from the tail rotor design and usage.

The Canadian Department of Defense now uses a 12.5-hour inspection interval for the detailed visual inspection using a 2-power magnifying glass for the T/R blades on their Model 412CF helicopters. This interval was implemented as a result of a risk assessment performed for the T/R blade failure. If damage is suspected, this is followed by a 10-power magnifying glass and appropriate measuring tools

(i.e. optical micrometer). The striation count for the failed blade indicates a crack propagation rate of approximately 77 hours TIS from damage initiation to blade failure.

We have determined that:

- The T/R blades are susceptible to impact damage from outside sources (gravel, stone, hail, etc.). The impact damage is the originating point for initiating fatigue cracks with subsequent growth until the blade fails from overload on the remaining intact structure;

- Fatigue cracks have also initiated from corrosion and corrosion pits;

- Model 205A, 205A-1, and certain 204B helicopters with the same part-numbered T/R blades as those installed on Model 212 and 412 helicopters should be included in this proposed AD; and

- Model 205B and 210 helicopters with the same type-designed T/R blades as those installed on Model 212 and 412 helicopters should also be included in this proposed AD.

We have reviewed the following Bell documents:

- Operations Safety Notice OSN 205-02-37, OSN 205B-02-10, OSN 212-02-39, OSN 412-02-25, OSN 412CF-02-05, and OSN UH-1H-II-02-3, dated August 27, 2002. That Operations Safety Notice applies to all owners and operators of Bell 205, 205B, 212, 412, 412CF, and UH-1H-II helicopters and was written to remind operators of the following:

- The importance of accomplishing a complete inspection of the T/R blades at specified inspection intervals;

- That the blades must be cleaned in order to perform an adequate visual inspection to determine their condition; and

- That maintenance manuals and component repair and overhaul manuals are to be consulted for damage limits and repair criteria as required.

- Alert Service Bulletin No. 412CF-03-20, dated February 6, 2003, which applies to Model 412CF helicopters and provides instructions for doing a visual inspection of certain T/R blades immediately and every 25 hours TIS in accordance with Model 412CF maintenance manual and instructions for sending the affected tail rotor blade

to DND "Calgary Supply Center" for refinishing and reidentification.

- Bell Maintenance Document C-12-146-000/MF-001, Mod 4, dated February 12, 2004, which applies to Model 412CF helicopters and specifies a tail rotor blade damage records check and a visual inspection for dents, nicks, cracks, paint chips, or blisters using a 2-power magnifying glass and a good source of light in specified areas of the tail rotor blades (reference 64-00-00, section 64-38, page 42).

This unsafe condition is likely to exist or develop on other helicopters of the same type designs. Therefore, the proposed AD would require the following actions:

- Before each start of the engines, visually checking each T/R blade for a crack;
 - Within 25 hours TIS or 15 days, whichever occurs first, and thereafter at intervals not to exceed 25 hours TIS or 15 days, whichever occurs first, cleaning and visually inspecting each T/R blade for a crack, corrosion, nick, scratch, or dent using a 3-power or higher magnifying glass and a bright light;
 - If certain damage is found, inspecting for a crack or corrosion using a 10-power or higher magnifying glass and measuring the depth of any damage; and
 - Before further flight, replacing any cracked T/R blade and repairing or replacing any otherwise unairworthy T/R blade.

The requirements of the proposed AD would be interim actions until either a more rigorous inspection is developed or a new blade that is more damage tolerant is designed. The manufacturer is currently considering a redesign of these T/R blades.

We estimate that this proposed AD would affect 388 helicopters of U.S. registry. There are approximately 184 Model 205A and 205A-1 helicopters, 8 Model 205B helicopters, 101 Model 212 helicopters, 80 Model 412, 412CF, and 412EP helicopters, and 15 modified Model 204B helicopters. Each visual check would take .125 hours, each visual inspection would take .5 hours, and 6 hours to remove and replace each T/R blade assembly, if necessary. The average labor rate is \$80. Replacement parts would cost \$11,243 for each T/R blade assembly. Based on these figures, the estimated cost impact of the proposed AD for all of the affected models would be \$1,847,295 assuming an average of 600 hours TIS per year for each helicopter resulting in 365 visual checks, 24 inspections, and 5 T/R blade assembly replacements for the total fleet.

Regulatory Findings

We have determined that this proposed AD would not have federalism implications under Executive Order 13132. Additionally, this proposed AD would not have a substantial direct effect on the States, on the relationship between the national Government and the States, or on the distribution of power and responsibilities among the various levels of government.

For the reasons discussed above, I certify that the proposed regulation:

1. Is not a "significant regulatory action" under Executive Order 12866;
2. Is not a "significant rule" under the DOT Regulatory Policies and Procedures (44 FR 11034, February 26, 1979); and
3. Will not have a significant economic impact, positive or negative, on a substantial number of small entities under the criteria of the Regulatory Flexibility Act.

We prepared a draft economic evaluation of the estimated costs to comply with this proposed AD. See the DMS to examine the draft economic evaluation.

Authority for This Rulemaking

Title 49 of the United States Code specifies the FAA's authority to issue rules on aviation safety. Subtitle I, section 106, describes the authority of the FAA Administrator. Subtitle VII, Aviation Programs, describes in more detail the scope of the Agency's authority.

We are issuing this rulemaking under the authority described in subtitle VII, part A, subpart III, section 44701, "General requirements." Under that section, Congress charges the FAA with promoting safe flight of civil aircraft in air commerce by prescribing regulations for practices, methods, and procedures the Administrator finds necessary for safety in air commerce. This regulation is within the scope of that authority because it addresses an unsafe condition that is likely to exist or develop on products identified in this rulemaking action.

List of Subjects in 14 CFR Part 39

Air transportation, Aircraft, Aviation safety, Safety.

The Proposed Amendment

Accordingly, pursuant to the authority delegated to me by the Administrator, the Federal Aviation Administration proposes to amend part 39 of the Federal Aviation Regulations (14 CFR part 39) as follows:

PART 39—AIRWORTHINESS DIRECTIVES

1. The authority citation for part 39 continues to read as follows:

Authority: 49 U.S.C. 106(g), 40113, 44701.

§ 39.13 [Amended]

2. Section 39.13 is amended by adding a new airworthiness directive to read as follows:

Bell Helicopter Textron: Docket No. FAA-2006-26219; Directorate Identifier 2004-SW-49-AD.

Applicability

The following model helicopters, with the specified tail rotor blade assembly (T/R blade) installed, certificated in any category:

Helicopter model	With T/R blade assembly, part number (P/N)
204B	212-010-750-009, -105, or -113.
205A and 205A-1.	212-010-750-009, -105, or -113.
205B	212-010-750-109, -111, -117, -125, or -135
	212-015-501-115 or -121.
210	212-010-001-101.
212	212-010-750-009, -105, or -113.
412	212-010-750-009, -011, -105, -107, -113, or -115.
412CF	212-010-750-009, -011, -105, -107, -113, or -115.
412EP	212-010-750-009, -011, -105, -107, -113, or -115.

Compliance

Required as indicated.

To prevent failure of a T/R blade and subsequent loss of control of the helicopter, accomplish the following:

(a) Before each start of the engines, visually check both sides of each T/R blade for a crack. An owner/operator (pilot) holding at least a private pilot certificate may perform this visual check and must enter compliance with this paragraph into the aircraft maintenance records in accordance with 14 CFR 43.11 and 91.417(a)(2)(v).

(b) Within 25 hours time-in-service (TIS) or 15 days, whichever occurs first, unless accomplished previously, and thereafter at intervals not to exceed 25 hours TIS or 15 days, whichever occurs first:

(1) Clean each T/R blade by hand using a mild degreaser and water to remove soot and grime on both sides of the blade using a coarse, loosely woven cotton cloth in a spanwise direction. Use a cloth with a color that contrasts with the color of the T/R blade so that a snag will be visible.

(2) Using a 3-power or higher magnifying glass and a bright light, visually inspect the T/R blade skins, leading edge spar, doublers, grip plates, and trailing edge for a crack, corrosion (may be indicated by blistering, peeling, flaking, bubbling, or cracked paint) and any other damage (including a nick, scratch, or dent). See Figure 1 of this AD. Pay particular attention to both sides of the T/R

blade in the area located 10 to 25 inches from the T/R blade tip (blade station 26 to 41—the T/R blade tip is located at blade station 51). Also pay particular attention to any blade surface that was snagged by the cloth, as that may be an indication of a crack or paint chip that could lead to corrosion.

1. Pitch Horn Blade Bolts.

2. Blade Grip Bolt Holes.
3. External Balance Weights.
4. Doubler.
5. Trailing Edge.
6. Skin.
7. Honeycomb Core.
8. Tip Block.
9. Balance Screws.

10. Spar.
11. Grip Plate.
12. Drain Hole Doubler.
13. Butt Block.
14. Inner Grip Plate.
15. Tip Closure.

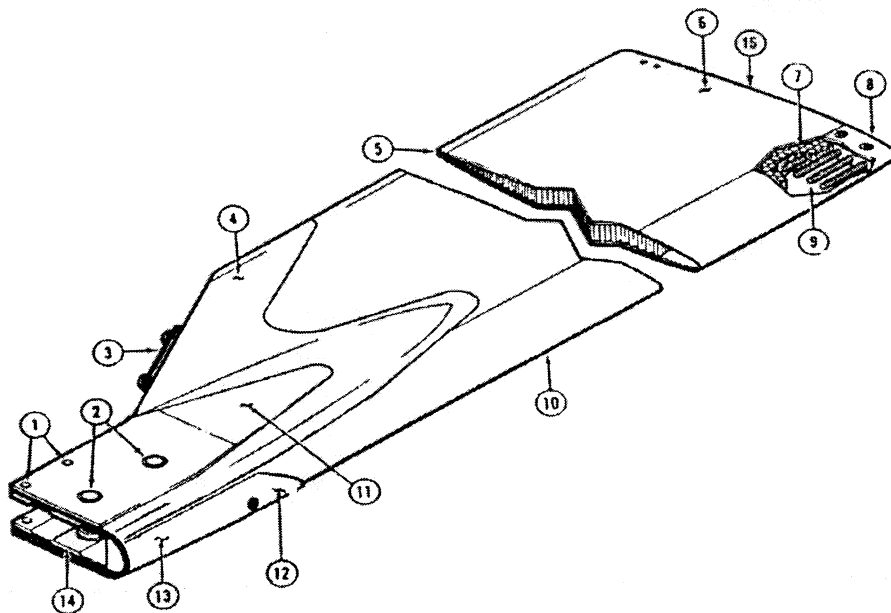

T/R Blade Assembly
Figure 1

(3) If any blistering, peeling, flaking, bubbling, or cracked paint is detected, remove the paint from the affected area and visually inspect the affected area for corrosion or a crack using a 10-power or higher magnifying glass. If any corrosion is found, measure the depth of the corrosion (a digital optical micrometer is one tool that can be used for this measurement).

(4) If a nick, scratch, or dent is found, visually inspect for a crack using 10-power or higher magnifying glass and measure the depth of the damage (a digital optical micrometer is one tool that can be used for this measurement).

(c) Before further flight:

(1) Replace any T/R blade that has a crack with an airworthy blade.

(2) Replace any T/R blade that has any corrosion, nick, scratch, dent, or other damage that exceeds any maximum repair limit with an airworthy blade.

Note 1: The maximum repair limits are specified in the applicable maintenance manual.

(3) Repair or replace with an airworthy blade any T/R blade that has any corrosion, nick, scratch, dent or other damage that is within the maximum repair limits.

Note 2: The repair procedures are specified in the applicable maintenance manual and component repair and overhaul manuals.

(d) To request a different method of compliance or a different compliance time for this AD, follow the procedures in 14 CFR 39.19. Contact the Manager, Rotorcraft Certification Office, Rotorcraft Directorate, FAA, Attn: Michael Kohner, Aviation Safety Engineer, Fort Worth, Texas 76193-0170, telephone (817) 222-5447, fax (817) 222-5783, for information about previously approved alternative methods of compliance.

Issued in Fort Worth, Texas, on October 26, 2006.

Mark R. Schilling,

*Acting Manager, Rotorcraft Directorate,
Aircraft Certification Service.*

[FR Doc. E6-18462 Filed 11-1-06; 8:45 am]

BILLING CODE 4910-13-P

DEPARTMENT OF THE TREASURY

Internal Revenue Service

26 CFR Parts 1, 20, 25, 31, 53, 54, and 56

[REG-103038-05]

RIN 1545-BE24

AJCA Modifications to the Section 6011 Regulations

AGENCY: Internal Revenue Service (IRS), Treasury.

ACTION: Notice of proposed rulemaking by cross-reference to temporary regulations.

SUMMARY: This document contains proposed regulations under section 6011 of the Internal Revenue Code that modify the rules relating to the disclosure of reportable transactions under section 6011. These regulations affect taxpayers participating in reportable transactions under section 6011, material advisors responsible for disclosing reportable transactions under section 6111, and material advisors responsible for keeping lists under section 6112.

DATES: Written or electronic comments and requests for a public hearing must be received by January 31, 2007.

ADDRESSES: Send submissions to: CC:PA:LPD:PR (REG-103038-05), room 5203, Internal Revenue Service, PO Box 7604, Ben Franklin Station, Washington, DC 20044. Submissions may be hand delivered Monday through Friday between the hours of 8 a.m. and 4 p.m. to CC:PA:LPD:PR (REG-103038-05), Courier's Desk, Internal Revenue Service, Crystal Mall 4 Building, 1901 S. Bell St., Arlington, VA, or sent electronically, via the IRS Internet site at <http://www.irs.gov/regs> or via the Federal eRulemaking Portal at www.regulations.gov (indicate IRS and REG-103038-05).

FOR FURTHER INFORMATION CONTACT: Concerning the proposed regulations, Tara P. Volungis or Charles Wien, 202-622-3070; concerning the submissions of comments and requests for hearing, Kelly Banks, 202-622-0392 (not toll-free numbers).

SUPPLEMENTARY INFORMATION:

Background

This document proposes to amend 26 CFR part 1 by modifying and clarifying the rules relating to the disclosure of reportable transactions under section 6011. This document also proposes to amend 26 CFR parts 20, 25, 31, 53, 54, and 56 by modifying the rules for purposes of estate, gift, employment, and pension and exempt organizations excise taxes that require the disclosure of listed transactions by certain taxpayers on their Federal tax returns under section 6011.

On February 28, 2003, the IRS issued final regulations under sections 6011, 6111, and 6112 (TD 9046) (the February 2003 regulations). The February 2003 regulations were published in the **Federal Register** (68 FR 10161) on March 4, 2003. On December 29, 2003, the IRS issued final regulations under section 6011 and 6112 (TD 9108) (the December 2003 regulations). The December 2003 regulations were published in the **Federal Register** (68 FR 75128) on December 30, 2003.

Since the publication of the February 2003 regulations and the December 2003 regulations, the American Jobs Creation Act of 2004, Public Law 108-357, 118 Stat. 1418, (AJCA) was enacted on October 22, 2004. The AJCA revised sections 6111 and 6112, thereby necessitating changes to the rules under section 6011. The IRS and Treasury Department also have received various comments and questions regarding the rules under § 1.6011-4. Consequently, the IRS and Treasury Department are proposing modifications to the rules regarding the disclosure of reportable transactions under § 1.6011-4.

It should be noted that section 516 of the Tax Increase Prevention and Reconciliation Act of 2005, Public Law 109-222, 120 Stat. 345, (TIPRA), enacted on May 17, 2006, includes new excise taxes that target prohibited tax shelter transactions to which a tax-exempt entity is a party. Prohibited tax shelter transactions consist of listed transactions, confidential transactions, and transactions with contractual protection under section 6011. TIPRA also contains new disclosure requirements, which apply not only to tax-exempt entities but also to taxable entities that are parties to prohibited tax shelter transactions involving tax-exempt entities, and makes penalties applicable for failure to comply with each new disclosure requirement. The IRS and Treasury Department will issue separate guidance regarding the disclosure provision in TIPRA.

Explanation of Provisions

A. Removal of Transactions With a Significant Book-Tax Difference

Under the current regulations in § 1.6011-4, there are six categories of reportable transactions. In accordance with the interim guidance provided in Notice 2006-6, 2006-5 I.R.B. 385, these proposed regulations eliminate the *transactions with a significant book-tax difference* category of reportable transaction that is in § 1.6011-4(b)(6). The IRS and Treasury Department have determined that this category of reportable transaction is no longer necessary due to the issuance of the Schedule M-3, "Net Income (Loss) Reconciliation for Corporations With Total Assets of \$10 Million or More", which now provides the IRS a more complete disclosure of book-tax differences for corporations. The Schedule M-3 reporting requirements will be extended to partnerships and S corporations. The removal of the book-tax difference category applies to transactions that otherwise would have to have been disclosed on or after January 6, 2006 (regardless of when the transaction was entered into).

B. Transactions of Interest

The IRS and Treasury Department are proposing as a new category of reportable transaction the *transactions of interest* reportable transaction. A transaction of interest is a transaction that the IRS and Treasury Department believe has a potential for tax avoidance or evasion, but for which the IRS and Treasury Department lack enough information to determine whether the transaction should be identified specifically as a tax avoidance transaction. Transactions of interest will be identified in published guidance. When the IRS and Treasury Department have gathered enough information to make an informed decision as to whether the transaction of interest is a tax avoidance type of transaction, the IRS and Treasury Department may take one or more actions, including removing the transaction from the transactions of interest category in published guidance, designating the transaction as a listed transaction, or providing a new category of reportable transaction. Listed transactions do not have to be identified as transactions of interest before the transactions are identified as listed transactions. It is anticipated that, upon finalization of these proposed regulations, the transactions of interest category of reportable transaction will apply to transactions entered into on or after November 2, 2006.