

the Administrator finds necessary for safety in air commerce. This regulation is within the scope of that authority because it addresses an unsafe condition that is likely to exist or develop on products identified in this rulemaking action.

Regulatory Findings

We have determined that this AD will not have federalism implications under Executive Order 13132. This AD will not have a substantial direct effect on the States, on the relationship between the national government and the States, or on the distribution of power and responsibilities among the various levels of government.

For the reasons discussed above, I certify that the regulation:

1. Is not a "significant regulatory action" under Executive Order 12866;
2. Is not a "significant rule" under the DOT Regulatory Policies and Procedures (44 FR 11034, February 26, 1979); and
3. Will not have a significant economic impact, positive or negative, on a substantial number of small entities under the criteria of the Regulatory Flexibility Act.

We prepared a regulatory evaluation of the estimated costs to comply with this AD and placed it in the AD docket. See the **ADDRESSES** section for a location to examine the regulatory evaluation.

List of Subjects in 14 CFR Part 39

Air transportation, Aircraft, Aviation safety, Incorporation by reference, Safety.

Adoption of the Amendment

Accordingly, under the authority delegated to me by the Administrator, the FAA amends 14 CFR part 39 as follows:

PART 39—AIRWORTHINESS DIRECTIVES

1. The authority citation for part 39 continues to read as follows:

Authority: 49 U.S.C. 106(g), 40113, 44701.

§ 39.13 [Amended]

2. The Federal Aviation Administration (FAA) amends § 39.13 by adding the following new airworthiness directive (AD):

2006-08-05 Fokker Services B.V.:
Amendment 39-14559. Docket No. FAA-2006-24429; Directorate Identifier 2006-NM-003-AD.

Effective Date

(a) This AD becomes effective April 28, 2006.

Affected ADs

(b) None.

Applicability

(c) This AD applies to Fokker Model F.28 Mark 0100 airplanes, certificated in any category; serial numbers 11290, 11296, 11323, 11329, and 11330, if modified in accordance with Fokker Service Bulletin SBF100-25-038 or SBF100-25-096.

Unsafe Condition

(d) This AD results from a report that certain structural provisions for an optional antenna are of insufficient strength. We are issuing this AD to prevent reduced structural integrity of the airplane.

Compliance

(e) You are responsible for having the actions required by this AD performed within the compliance times specified, unless the actions have already been done.

Installation

(f) Within 24 months or 3,000 flight cycles after the effective date of this AD, whichever occurs first: Reinforce the fuselage at the emergency locator transmitter system's antenna area in accordance with Part 1 or Part 2 of the Accomplishment Instructions of Fokker Service Bulletin SBF100-53-100, dated February 28, 2005, including Drawing W98488, Sheets 07 and 08, Issue F, dated February 9, 2004, and Sheets 09 and 10, Issue F, dated February 10, 2004.

Alternative Methods of Compliance (AMOCs)

(g)(1) The Manager, International Branch, ANM-116, Transport Airplane Directorate, FAA, has the authority to approve AMOCs for this AD, if requested in accordance with the procedures found in 14 CFR 39.19.

(2) Before using any AMOC approved in accordance with § 39.19 on any airplane to which the AMOC applies, notify the appropriate principal inspector in the FAA Flight Standards Certificate Holding District Office.

Related Information

(h) Dutch airworthiness directive NL-2005-004, dated April 29, 2005, also addresses the subject of this AD.

Material Incorporated by Reference

(i) You must use Fokker Service Bulletin SBF100-53-100, dated February 28, 2005, including Drawing W98488, Sheets 07 and 08, Issue F, dated February 9, 2004, and Sheets 09 and 10, Issue F, dated February 10, 2004, to perform the actions that are required by this AD, unless the AD specifies otherwise. Fokker Service Bulletin SBF100-53-100 contains the following effective pages:

Page No.	Revision level shown on page	Date shown on page
1-9	Original	February 28, 2005.
Drawing W98488		
07, 08	F	February 9, 2004.

Page No.	Revision level shown on page	Date shown on page
09, 10	F	February 10, 2004.

The Director of the Federal Register approved the incorporation by reference of this document in accordance with 5 U.S.C. 552(a) and 1 CFR part 51. Contact Fokker Services B.V., P.O. Box 231, 2150 AE Nieuw-Vennep, the Netherlands, for a copy of this service information. You may review copies at the Docket Management Facility, U.S. Department of Transportation, 400 Seventh Street, SW., Room PL-401, Nassif Building, Washington, DC; on the Internet at <http://dms.dot.gov>; or at the National Archives and Records Administration (NARA). For information on the availability of this material at the NARA, call (202) 741-6030, or go to http://www.archives.gov/federal_register/code_of_federal_regulations/ibr_locations.html.

Issued in Renton, Washington, on April 4, 2006.

Kevin M. Mullin,

Acting Manager, Transport Airplane Directorate, Aircraft Certification Service.

[FR Doc. 06-3480 Filed 4-12-06; 8:45 am]

BILLING CODE 4910-13-P

DEPARTMENT OF TRANSPORTATION

Federal Aviation Administration

14 CFR Part 39

[Docket No. **FAA-2006-24446**; Directorate Identifier **2005-SW-15-AD**; Amendment **39-14561**; AD **2006-08-06**]

RIN 2120-AA64

Airworthiness Directives; Eurocopter France Model SA-360C, SA-365C, SA-365C1, and SA-365C2 Helicopters

AGENCY: Federal Aviation Administration, DOT.

ACTION: Final rule; request for comments.

SUMMARY: This amendment adopts a new airworthiness directive (AD) for Eurocopter France (Eurocopter) Model SA-360C, SA-365C, SA-365C1, and SA-365C2 helicopters. This action requires inspecting the main gearbox (MGB) base plate for a crack and replacing the MGB if a crack is found. This amendment is prompted by the discovery of a crack in a MGB base plate. The actions specified in this AD are intended to detect a crack in a MGB base plate and prevent failure of one of the MGB attachment points to the frame, which could result in severe vibration and subsequent loss of control of the helicopter.

DATES: Effective April 28, 2006.

Comments for inclusion in the Rules Docket must be received on or before June 12, 2006.

ADDRESSES: Use one of the following addresses to submit comments on this AD:

- DOT Docket Web site: Go to <http://dms.dot.gov> and follow the instructions for sending your comments electronically;
- Government-wide rulemaking Web site: Go to <http://www.regulations.gov> and follow the instructions for sending your comments electronically;
- Mail: Docket Management Facility; U.S. Department of Transportation, 400 Seventh Street, SW., Nassif Building, Room PL-401, Washington, DC 20590;
- Fax: (202) 493-2251; or
- Hand Delivery: Room PL-401 on the plaza level of the Nassif Building, 400 Seventh Street, SW., Washington, DC, between 9 a.m. and 5 p.m., Monday through Friday, except Federal holidays.

You may get the service information identified in this AD from American Eurocopter Corporation, 2701 Forum Drive, Grand Prairie, Texas 75053-4005, telephone (972) 641-3460, fax (972) 641-3527.

Examining the Docket

You may examine the docket that contains the AD, any comments, and other information on the Internet at <http://dms.dot.gov>, or in person at the Docket Management System (DMS) Docket Offices between 9 a.m. and 5 p.m., Monday through Friday, except Federal holidays. The Docket Office (telephone (800) 647-5227) is located on the plaza level of the Department of Transportation Nassif Building at the street address stated in the **ADDRESSES** section. Comments will be available in the AD docket shortly after the DMS receives them.

FOR FURTHER INFORMATION CONTACT: Ed Cuevas, Aviation Safety Engineer, FAA, Rotorcraft Directorate, Safety Management Group, Fort Worth, Texas 76193-0111, telephone (817) 222-5355, fax (817) 222-5961.

SUPPLEMENTARY INFORMATION: This amendment adopts a new AD for

Eurocopter Model SA-360C, SA-365C, SA-365C1, and SA-365C2 helicopters with an MGB base plate, part number (P/N) 360A32-2311-02 or P/N 360A32-2311-03. This action requires visually inspecting the MGB for a crack in the MGB base plate, close to the attachment hole, using a 10x or higher magnifying glass. Stripping paint from the inspection area is also required, but only before the initial inspection. This amendment is prompted by the discovery of a crack in the MGB base plate of a Eurocopter Model AS-365 N2 helicopter, which is of similar type design to the helicopter models affected by this AD. The cause of the crack is under investigation; therefore, this AD is an interim action until the cause of the crack can be determined. The crack was located very close to the attachment points of one of the laminated pads, and it propagated to the inside of the MGB base plate and then continued into the MGB casing. This condition, if not detected, could result in failure of one of the MGB attachment points to the frame, which could result in severe vibration and subsequent loss of control of the helicopter.

We have previously issued AD 2004-16-15, Amendment 39-13771 (69 FR 51358), that applies to Eurocopter Model AS-365N2, AS 365 N3, EC 155B, EC155B1, SA-365N and N1, and SA-366G1 helicopters with an MGB base plate, P/N 366A32-1062-03 or P/N 366A32-1062-06. Since the issuance of that AD, the Direction Générale de L'Aviation Civile (DGAC), the airworthiness authority for France, notified us that an unsafe condition may also exist on Eurocopter Model SA 360 C and SA 365 C, C1, C2, and C3 helicopters. The SA 365 C3 is not type certificated in the United States. The DGAC advises of the discovery of a crack on the MGB base plate of a Model AS 365 N2 helicopter.

Eurocopter has issued Alert Service Bulletin No. 05.25, dated February 17, 2005 (ASB), which specifies visually inspecting the MGB base plate for the absence of cracks. In addition, the ASB

states that a 10x magnifying glass can be used to facilitate the crack inspection. If in doubt about the existence of a crack, the ASB specifies inspecting for a crack using a dye-penetrant crack detection inspection. The ASB also states that after the crack was discovered on the Eurocopter Model AS365 N2 helicopter, the Eurocopter Model SA360 C and SA365C, C1, C2, and C3 helicopters were excluded from monitoring requirements. However, after issuing an Alert Telex, further cases of cracks were reported on helicopters covered by the monitoring requirement. Also, since the issuance of their initial service information, additional investigations and examinations have shown that the helicopter versions initially excluded from the monitoring requirements are also concerned by the potential risk and their MGB bottom plate must also be monitored. The DGAC classified this ASB as mandatory and issued AD No. F-2005-036, dated March 2, 2005, to ensure the continued airworthiness of these helicopters in France.

These helicopter models are manufactured in France and are type certificated for operation in the United States under the provisions of 14 CFR 21.29 and the applicable bilateral agreement. Pursuant to the applicable bilateral agreement, the DGAC has kept the FAA informed of the situation described above. The FAA has examined the findings of the DGAC, reviewed all available information, and determined that AD action is necessary for products of this type design that are certificated for operation in the United States.

This unsafe condition is likely to exist or develop on other helicopters of the same type design. Therefore, this AD is being issued to detect a crack in the MGB base plate and prevent failure of a MGB attachment point to the frame, which could result in severe vibration and subsequent loss of control of the helicopter. This AD requires initial and repetitive inspections of the MGB base plate for cracking at the following intervals:

For any MGB that:	Accomplish the AD actions:
(a) Has less than 26,900 cycles and has never been overhauled or repaired.	On or before accumulating 26,900 cycles and thereafter at intervals not to exceed 55 hours time-in-service (TIS).
(b) Has 26,900 or more cycles and has never been overhauled or repaired.	Before further flight and thereafter at intervals not to exceed 55 hours TIS.
(c) Is installed that has been overhauled or repaired	Before further flight and thereafter at intervals not to exceed 55 hours TIS.

One cycle equates to one helicopter landing in which a landing gear touches the ground.

None of the Eurocopter Model SA-360C, SA-365C, SA-365C1, and SA-365C2 helicopters affected by this action are on the U.S. Register. All helicopters included in the applicability of this rule are currently operated by non-U.S. operators under foreign registry; therefore, they are not directly affected by this AD action. However, the FAA considers that this rule is necessary to ensure that the unsafe condition is addressed in the event that any of these subject helicopters are imported and placed on the U.S. Register in the future.

Should an affected helicopter be imported and placed on the U.S. Register in the future, it would take approximately 0.5 work hour for the initial inspection and 0.25 work hour for each recurring inspection. Replacing the MGB, if necessary, would take approximately 4 work hours to accomplish, at an average labor rate of \$65 per work hour. It would cost approximately \$25,000 to repair a cracked MGB base plate. Based on these figures, the cost impact of this AD would be \$25,455, assuming that one helicopter is imported and inspected 11 times (the initial inspection plus 10 recurring inspections) and the MGB is replaced once.

Since this AD action does not affect any helicopter that is currently on the U.S. register, it has no adverse economic impact and imposes no additional burden on any person. Therefore, notice and public procedures hereon are unnecessary and the amendment may be made effective in less than 30 days after publication in the **Federal Register**.

Comments Invited

This AD is a final rule that involves requirements that affect flight safety and was not preceded by notice and an opportunity for public comment; however, we invite you to submit any written data, views, or arguments regarding this AD. Send your comments to an address listed under **ADDRESSES**. Include "Docket No. FAA-200X-XXXXX; Directorate Identifier 2005-SW-15-AD" at the beginning of your comments. We specifically invite

comments on the overall regulatory, economic, environmental, and energy aspects of the AD. We will consider all comments received by the closing date and may amend the AD in light of those comments.

We will post all comments we receive, without change, to <http://dms.dot.gov>, including any personal information you provide. We will also post a report summarizing each substantive verbal contact with FAA personnel concerning this AD. Using the search function of our docket Web site, you can find and read the comments to any of our dockets, including the name of the individual who sent the comment. You may review the DOT's complete Privacy Act Statement in the **Federal Register** published on April 11, 2000 (65 FR 19477-78), or you may visit <http://dms.dot.gov>.

Regulatory Findings

We have determined that notice and prior public comment are unnecessary in promulgating this regulation; therefore, it can be issued immediately to correct an unsafe condition in aircraft since none of these model helicopters are registered in the United States. We have also determined that this regulation is not a "significant regulatory action" under Executive Order 12866. It has been determined further that this action involves an emergency regulation under DOT Regulatory Policies and Procedures (44 FR 11034, February 26, 1979). If it is determined that this emergency regulation otherwise would be significant under DOT Regulatory Policies and Procedures, a final regulatory evaluation will be prepared and placed in the AD docket.

Authority for This Rulemaking

Title 49 of the United States Code specifies the FAA's authority to issue rules on aviation safety. Subtitle I, section 106, describes the authority of the FAA Administrator. Subtitle VII, Aviation Programs, describes in more detail the scope of the Agency's authority.

We are issuing this rulemaking under the authority described in subtitle VII, part A, subpart III, section 44701, "General requirements." Under that section, Congress charges the FAA with promoting safe flight of civil aircraft in air commerce by prescribing regulations for practices, methods, and procedures the Administrator finds necessary for safety in air commerce. This regulation is within the scope of that authority because it addresses an unsafe condition that is likely to exist or develop on products identified in this rulemaking action.

List of Subjects in 14 CFR Part 39

Air transportation, Aircraft, Aviation safety, Safety.

Adoption of the Amendment

Accordingly, pursuant to the authority delegated to me by the Administrator, the Federal Aviation Administration amends part 39 of the Federal Aviation Regulations (14 CFR part 39) as follows:

PART 39—AIRWORTHINESS DIRECTIVES

- 1. The authority citation for part 39 continues to read as follows:

Authority: 49 U.S.C. 106(g), 40113, 44701.

§ 39.13 [Amended]

- 2. Section 39.13 is amended by adding a new airworthiness directive to read as follows:

2006-08-06 Eurocopter France:

Amendment 39-14561. Docket No. FAA-2006-24446; Directorate Identifier 2005-SW-15-AD.

Applicability

Model SA-360C, SA-365C, SA-365C1, and SA-365C2 helicopters with a main gearbox (MGB) base plate, part number (P/N) 360A32-2311-02 or P/N 360A32-2311-03 installed, certificated in any category.

Compliance

Required as indicated in the following compliance table, unless accomplished previously, and before installing a replacement main gearbox (MGB).

COMPLIANCE TABLE

For any MGB that:	Accomplish the AD actions:
(a) Has less than 26,900 cycles and has never been overhauled or repaired.	On or before accumulating 26,900 cycles and thereafter at intervals not to exceed 55 hours time-in-service (TIS).
(b) Has 26,900 or more cycles and has never been overhauled or repaired.	Before further flight and thereafter at intervals not to exceed 55 hours TIS.
(c) Is installed that has been overhauled or repaired	Before further flight and thereafter at intervals not to exceed 55 hours TIS.

One cycle equates to one helicopter landing in which a landing gear touches the ground.

To detect a crack in a MGB base plate and prevent failure of one of the MGB attachment points to the frame, which could result in severe vibration and subsequent loss of

control of the helicopter, accomplish the following:

(a) Before the initial inspection at the time indicated in the compliance table, strip the

paint from area "D" on both sides ("B" and "C") of the MGB base plate as depicted in Figure 1 of this AD.

BILLING CODE 4910-13-P

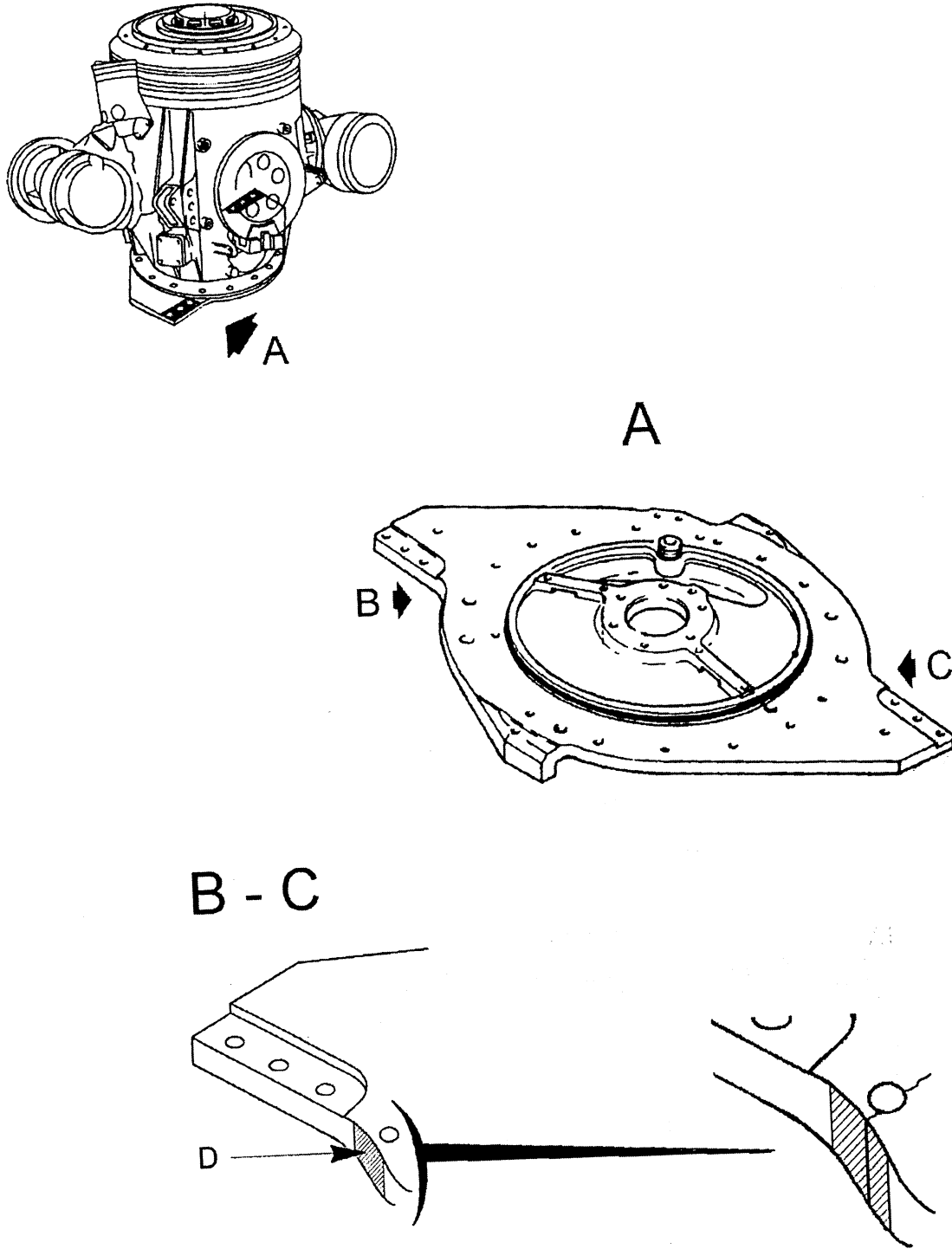

Figure 1

(b) At the times indicated in the compliance table, inspect area “D” of the MGB base plate for a crack using a 10x or higher magnifying glass. Area “D” to be inspected is depicted in Figure 1 of this AD.

Note 1: Eurocopter France Alert Service Bulletin No. 05.25, dated February 17, 2005, pertain to the subject of this AD.

(c) If a crack is found in a MGB base plate, remove and replace the MGB with an airworthy MGB before further flight.

(d) To request a different method of compliance or a different compliance time for this AD, follow the procedures in 14 CFR 39.19. Contact the Manager, Safety Management Group, Rotorcraft Directorate, FAA, ATTN: Ed Cuevas, Fort Worth, Texas 76193-0111, telephone (817) 222-5355, fax (817) 222-5961, for information about previously approved alternative methods of compliance.

(e) This amendment becomes effective on April 28, 2006.

Note 2: The subject of this AD is addressed in Direction Générale de L’Aviation Civile (France) AD No. F-2005-036, dated March 2, 2005.

Issued in Fort Worth, Texas, on April 5, 2006.

David A. Downey,

Manager, Rotorcraft Directorate, Aircraft Certification Service.

[FR Doc. 06-3535 Filed 4-12-06; 8:45 am]

BILLING CODE 4910-13-P

DEPARTMENT OF TRANSPORTATION

Federal Aviation Administration

14 CFR Part 39

[Docket No. FAA-2006-24438; Directorate Identifier 2006-NM-061-AD; Amendment 39-14560; AD 2006-04-13 R1]

RIN 2120-AA64

Airworthiness Directives; Gulfstream Model GIV-X and GV-SP Series Airplanes

AGENCY: Federal Aviation Administration (FAA), Department of Transportation (DOT).

ACTION: Final rule; request for comments.

SUMMARY: The FAA is revising an existing airworthiness directive (AD),

which applies to certain Gulfstream Model GIV-X and GV-SP series airplanes. That AD currently requires revising the Limitations section of the airplane flight manual (AFM) by incorporating new procedures to follow in the event that the cockpit displays go blank or malfunction. This AD allows for the use of alternative AFM revisions for a certain subset of the existing applicability. This AD results from a report that all four of the cockpit flight panel display units simultaneously went blank during flight. We are issuing this AD to ensure that the flightcrew is advised of the appropriate procedures to follow in the event that the cockpit displays go blank or malfunction, which could result in a reduction of the flightcrew’s situational awareness and possible loss of control of the airplane.

DATES: The effective date of this AD is March 13, 2006.

On March 13, 2006 (71 FR 9436, February 24, 2006), the Director of the Federal Register approved the incorporation by reference of certain other publications.

We must receive any comments on this AD by June 12, 2006.

ADDRESSES: Use one of the following addresses to submit comments on this AD:

- DOT Docket Web site: Go to <http://dms.dot.gov> and follow the instructions for sending your comments electronically.

- Government-wide rulemaking Web site: Go to <http://www.regulations.gov> and follow the instructions for sending your comments electronically.

- Mail: Docket Management Facility; U.S. Department of Transportation, 400 Seventh Street, SW., Nassif Building, Room PL-401, Washington, DC 20590.

- Fax: (202) 493-2251.

- Hand Delivery: Room PL-401 on the plaza level of the Nassif Building, 400 Seventh Street, SW., Washington, DC, between 9 a.m. and 5 p.m., Monday through Friday, except Federal holidays.

Contact Gulfstream Aerospace Corporation, Technical Publications Dept., P.O. Box 2206, Savannah, Georgia 31402-2206, for service information identified in this AD.

FOR FURTHER INFORMATION CONTACT: Robert Chupka, Aerospace Engineer, Systems and Equipment Branch, ACE-119A, Atlanta Aircraft Certification Office, FAA, One Crown Center, 1895 Phoenix Boulevard, Suite 450, Atlanta, Georgia 30349; telephone (770) 703-6070; fax (770) 703-6097.

SUPPLEMENTARY INFORMATION:

Discussion

On February 14, 2006, we issued AD 2006-04-13, amendment 39-14495 (71 FR 9436, February 24, 2006). That AD applies to certain Gulfstream Model GIV-X and GV-SP series airplanes. That AD requires revising the Limitations section of the airplane flight manual (AFM) by incorporating new procedures to follow in the event that the cockpit displays go blank or malfunction. That AD resulted from a report that all four of the cockpit flight panel display units simultaneously went blank during flight. The actions specified in that AD are intended to ensure that the flightcrew is advised of the appropriate procedures to follow in the event that the cockpit displays go blank or malfunction, which could result in a reduction of the flightcrew’s situational awareness and possible loss of control of the airplane.

Actions Since AD Was Issued

Since we issued AD 2006-04-13, the European Aviation Safety Agency (EASA) informed us that the information contained in the Joint Aviation Authority (JAA) Gulfstream AFM revisions is considered acceptable for airplanes operated under and in accordance with the JAA and EASA regulations, supervision, and oversight, and should be added to the AD. We inadvertently omitted that information from AD 2006-04-13; therefore, we have added a new Note 2 to this AD to give credit for those revisions.

Relevant Service Information

We have reviewed the revisions to the Limitations section of Gulfstream G350, G450, G500, and G550 AFMs, as listed in the table below:

GULFSTREAM AFM REVISIONS

Affected airplane models	AFM	Revision level	Revision date
Model GIV-X	Gulfstream G350	3	January 25, 2006.
	GAC-AC-JAA-G350-OPS-0001		
Model GIV-X	Gulfstream G450	3	January 25, 2006.
	GAC-AC-JAA-G450-OPS-0001		
Model GV-SP	Gulfstream G500	3	January 25, 2006.
	GAC-AC-JAA-G500-OPS-0001		