

copy of the performance bond, including all details and conditions.

(c) A licensee will be considered to be in default if it fails to meet any milestone deadline set forth in § 25.164, and, at the time of milestone deadline, the licensee has not provided a sufficient basis for extending the milestone.

(d) An NGSO-like licensee will be permitted to reduce the amount of the bond by 20 percent of the original bond amount upon successfully meeting a milestone deadline set forth in § 25.164(b). A GSO-like licensee will be permitted to reduce the amount of the bond by 25 percent of the original bond amount upon successfully meeting a milestone deadline set forth in § 25.164(a).

■ 28. Amend § 25.210 by removing and reserving paragraphs (e) and (g), and revising paragraph (f) to read as follows:

**§ 25.210 Technical requirements for space stations in the Fixed-Satellite Service.**

\* \* \* \* \*

(e) [Reserved]

(f) All space stations in the Fixed Satellite Service in the 3600–3700 MHz, 3700–4200 MHz, 5091–5250 MHz, 5825–5925 MHz, 5925–6425 MHz, 6425–6525 MHz, 6525–6700 MHz, 6700–7025 MHz, 10.7–10.95 GHz, 10.95–11.2 GHz, 11.2–11.45 GHz, 11.45–11.7 GHz, 11.7–12.2 GHz, 12.2–12.7 GHz, 12.75–13.15 GHz, 13.15–13.2125 GHz, 13.2125–13.25 GHz, 13.75–14.0 GHz, 14.0–14.5 GHz and 15.43–15.63 GHz bands shall employ state-of-the-art full frequency reuse either through the use of orthogonal polarizations within the same beam and/or the use of spatially independent beams.

(g) [Reserved]

\* \* \* \* \*

■ 29. Add § 25.217 to subpart C to read as follows:

**§ 25.217 Default service rules.**

(a) The technical rules in this section apply only to licenses to operate a satellite system in a frequency band granted after a domestic frequency allocation has been adopted for that frequency band, but before any frequency-band-specific service rules have been adopted for that frequency band.

(b)(1) For all NGSO-like satellite licenses for which the application was filed pursuant to the procedures set forth in § 25.157 after August 27, 2003, authorizing operations in a frequency band for which the Commission has not adopted frequency band-specific service rules at the time the license is granted, the licensee will be required to comply

with the following technical requirements, notwithstanding the frequency bands specified in these rule provisions: §§ 25.142(d), 25.143(b)(2)(ii), 25.143(b)(2)(iii), 25.204(g), 25.210(c), 25.210(d), 25.210(f), 25.210(i), 25.210(k), and 25.210(l).

(2) In addition to the requirements set forth in paragraph (b)(1) of this section, the Commission will coordinate with the National Telecommunications and Information Administration (NTIA) regarding the operations of any licensees authorized to operate in a shared government/non-government frequency band, pursuant to the procedure set forth in § 25.142(b)(2)(ii).

(3) Earth station licensees authorized to operate with one or more space stations described in paragraph (b)(1) of this section shall comply with the requirements in § 25.136. In addition, earth station licensees authorized to operate with one or more space stations described in paragraph (b)(1) of this section in frequency bands shared with terrestrial wireless services shall comply with the requirements in § 25.203(c).

(c)(1) For all GSO-like satellite licenses for which the application was filed pursuant to the procedures set forth in § 25.158 after August 27, 2003, authorizing operations in a frequency band for which the Commission has not adopted frequency band-specific service rules at the time the license is granted, the licensee will be required to comply with the following technical requirements, notwithstanding the frequency bands specified in these rule provisions: §§ 25.142(d), 25.143(b)(2)(iv), 25.204(g), 25.210(c), 25.210(d), 25.210(f), 25.210(i), 25.210(j), 25.210(k), and 25.210(l).

(2) In addition to the requirements set forth in paragraph (c)(1) of this section, the Commission will coordinate with the National Telecommunications and Information Administration (NTIA) regarding the operations of any licensees authorized to operate in a shared government/non-government frequency band, pursuant to the procedure set forth in § 25.142(b)(2)(ii).

(3) Earth station licensees authorized to operate with one or more space stations described in paragraph (c)(1) of this section shall comply with the earth station antenna performance verification requirements in § 25.132, and the antenna gain pattern requirements in §§ 25.209(a) and (b). In addition, earth station licensees authorized to operate with one or more space stations described in paragraph (c)(1) of this section in frequency bands shared with terrestrial wireless services shall comply with the requirements in § 25.203(c).

(4) In addition to the requirements set forth in paragraph (c)(3) of this section, earth station licensees with a gain equivalent or higher than the gain of a 1.2 meter antenna operating in the 14.0–14.5 GHz band, authorized to operate with one or more space stations described in paragraph (c)(1) of this paragraph in frequency bands greater than 14.5 GHz shall be required to comply with the antenna input power density requirements set forth in § 25.212(c).

(d) Applicants requesting authorization of a satellite subject to paragraphs (b) or (c) of this section must submit a narrative statement describing the debris mitigation design and operational strategies, if any, that they will use. Applicants are specifically required to submit a casualty risk assessment if planned post-mission disposal involves atmospheric re-entry of the spacecraft.

(e) In the event that the Commission adopts frequency band-specific service rules for a particular frequency band after it has granted one or more space station or earth station licenses for operations in that frequency band, those licensees will be required to come into compliance with the frequency band-specific service rules within 30 days of the effective date of those rules, unless otherwise specified by either Commission or Bureau Order.

[FR Doc. 03–21649 Filed 8–26–03; 8:45 am]

BILLING CODE 6712-01-P

**DEPARTMENT OF COMMERCE**

**National Oceanic and Atmospheric Administration**

**50 CFR Part 223**

[Docket No.030725185–3207–02; I.D. 071403B]

RIN 0648–AR34

**Endangered and Threatened Wildlife; Sea Turtle Conservation Requirements**

**AGENCY:** National Marine Fisheries Service (NMFS), National Oceanic and Atmospheric Administration (NOAA), Commerce.

**ACTION:** Final rule.

**SUMMARY:** NMFS is amending the turtle excluder device (TED) regulations that require most shrimp trawlers to use Turtle Excluder Devices (TEDs) in the southeastern Atlantic and the Gulf of Mexico, to reduce the incidental capture of endangered and threatened sea turtles during shrimp trawling. Specifically, NMFS is allowing the use of a design of

a hooped hard TED ("the Coulon TED") that is capable of releasing large loggerhead and green turtles as well as leatherback turtles.

**DATES:** This final rule is effective August 21, 2003.

**ADDRESSES:** Copies of the environmental assessment can be obtained from the Protected Resources Division, Southeast Regional Office, 9721 Executive Center Drive, North, Suite 102 St. Petersburg, Florida, 33702.

**FOR FURTHER INFORMATION CONTACT:** Robert Hoffman (ph. 727-570-5312, fax 727-570-5517, e-mail [Robert.Hoffman@noaa.gov](mailto:Robert.Hoffman@noaa.gov)), or Barbara A. Schroeder (ph. 301-713-1401, fax 301-713-0376, e-mail [Barbara.Schroeder@noaa.gov](mailto:Barbara.Schroeder@noaa.gov)).

**SUPPLEMENTARY INFORMATION:**

**Background**

All sea turtles that occur in U.S. waters are listed as either endangered or threatened under the Endangered Species Act of 1973 (ESA). The Kemp's ridley (*Lepidochelys kempii*), leatherback (*Dermochelys coriacea*), and hawksbill (*Eretmochelys imbricata*) turtles are listed as endangered. The loggerhead (*Caretta caretta*) and green (*Chelonia mydas*) turtles are listed as threatened, except for breeding populations of green turtles in Florida and on the Pacific coast of Mexico, which are listed as endangered.

Sea turtles are incidentally taken and killed as a result of numerous activities, including fishery trawling activities in the Gulf of Mexico and along the Atlantic seaboard. Under the ESA and its implementing regulations, taking sea turtles is prohibited, with exceptions identified in 50 CFR 223.206, or if in accordance with the terms and conditions of a biological opinion issued under section 7 of the ESA or an incidental take permit issued under section 10 of the Act. The incidental taking of turtles during shrimp or summer flounder trawling is exempted from the taking prohibition of section 9 of the ESA if the conservation measures specified in the sea turtle conservation regulations (50 CFR 223) are followed. The regulations require most shrimp trawlers and summer flounder trawlers operating in the southeastern United States (Atlantic Area, Gulf Area, and summer flounder sea turtle protection area, see 50 CFR 223.206) to have a NMFS-approved TED installed in each net that is rigged for fishing to provide for the escape of sea turtles. TEDs currently approved by NMFS include single-grid hard TEDs and hooped hard TEDs conforming to a generic description, the flounder TED, and one

type of soft TED the Parker soft TED (see 50 CFR 223.207).

TEDs incorporate an escape opening, usually covered by a webbing flap, that allows sea turtles to escape from trawl nets. To be approved by NMFS, a TED design must be shown to be 97 percent effective in excluding sea turtles during testing based upon specific testing protocols (50 CFR 223.207(e)(1)). Most approved hard TEDs are described in the regulations (50 CFR 223.207 (a)) according to generic criteria based upon certain parameters of TED design, configuration, and installation, including height and width dimensions of the TED opening through which the turtles escape.

*February 21, 2003, Amendments to the Sea Turtle Conservation Regulations*

On February 21, 2003, NMFS issued a final rule (68 FR 8456), amending the sea turtle conservation regulations to protect large loggerhead, green, and leatherback sea turtles. The final rule became effective April 15, 2003, with the exception of the Gulf Area where it will become effective on August 21, 2003. The February final rule requires that all shrimp trawlers fishing in the offshore waters of the southeastern United States (Atlantic Area and Gulf Area) and the inshore waters of Georgia and South Carolina use either a double cover flap TED, a single-grid hard TED with a 71-inch (180-cm) opening, or a Parker soft TED with a 96-inch (244-cm) opening in each net rigged for fishing. In inshore waters, except those of Georgia and South Carolina, the rule allows the use of a single-grid hard TED with a 44-inch (112-cm) opening, a Parker soft TED with a 56-inch (142-cm) opening, and a hooped hard TED with a 35-inch (89-cm) by 27-inch (69-cm) escape opening.

Since publication of the final rule (68 FR 8456, February 21, 2003), NMFS has tested a new hooped hard TED design developed in Louisiana (the Coulon TED) that contains a larger escape opening than the hooped hard TED design used in inshore waters. Louisiana fishermen prefer the Coulon TED due to its higher shrimp retention, and its efficiency and quickness in releasing both turtles and fish bycatch. Because of the desire of fishermen to continue to use this style of TED in offshore waters and their assertion that it could indeed be made large enough to release leatherback turtles, the Southeast Fisheries Science Center's Harvesting Systems and Engineering Branch worked with the inventor of the Coulon TED and fishermen who use it to develop and test a large Coulon style TED to evaluate its ability to release

large loggerhead, green, and leatherback turtles.

*Large Hooped Hard TED Testing*

NMFS tested the large Coulon style TED using testing protocols designed to evaluate a TED's ability to release large turtles. The protocols were developed during the testing and approval of the double cover TED (66 FR 24287, May 14, 2001). NMFS used the average carapace measurements of 15 nesting female leatherback turtles to construct a pipe-framed model of a leatherback turtle. This model measured 40 inches wide by 21 inches (102 cm by 53 cm) deep. The test was performed by a diver swimming repeatedly through the trawl with the model and pushing it through the TED opening. During these tests, the diver was able to push the model through the opening with ease. When the model was inverted (simulating the dorsal surface of the turtle oriented against the TED frame), the diver was still able to push the model through the opening with ease.

A large Coulon style TED with a hinged door covering the escape opening to within 12 inches (30 cm) from the back edge of the opening was also tested to determine its ability to release small turtles. The small turtle protocol calls for the release of 25 turtles, released one at a time, into a trawl towed at 2.5 knots (55 FR 41092, October 9, 1990). Each turtle is given 5 minutes to escape; if the turtle does not escape within 5 minutes, it is retrieved by divers and is considered to have been captured. The capture rate is then compared to that of a control TED (in this case a top-opening double cover flap TED).

During the week of June 22, 2003, 25 small turtles were exposed to the large Coulon style TED with a hinged door and all 25 turtles escaped quickly and easily. The Southeast Fisheries Science Center's Harvesting Systems and Engineering Branch believes that this particular configuration of the large Coulon style TED would be the most difficult for small turtles to escape from because of the weight and size of the door. However, when compared to the control TED, the average escape times did not differ significantly; the average escape time for the control TED was 62 seconds compared to 68 seconds for the Coulon style TED with the hinged door. Based upon the tests described above, NMFS determined that the large Coulon style TED meets the regulatory turtle release rate requirement.

Therefore, on July 30, 2003, NMFS published a proposed rule (68 FR 44722) requesting comments on allowing the use of a large hooped hard

TED in the offshore waters of the Atlantic and Gulf of Mexico. NMFS received two comments on the proposed rule.

#### Public Comments

*Comment 1:* The University of Georgia Marine Extension Service is concerned that the codified text specifying construction materials for TEDs in the proposed rule requires that if steel rod is used to construct a single grid hard TED or an inshore hooped hard TED the steel rod used must have an outside diameter of 1/2 inch (1.27 cm). This is a significant change from the required 1/4 inch (.64 cm) currently required.

*Response:* NMFS thanks the commenter for bringing this to our attention. This is a typographical error in the proposed rule and has been corrected in this final rule.

*Comment 2:* An environmental organization stated that although they do not oppose NMFS allowing the use of the Coulon TED, they asserted that any certified TED must continue to be reviewed, monitored and enforced to ensure that it is effectively releasing sea

turtles. The commenter stated that NMFS must increase the monitoring and enforcement of the TED regulations to ensure that these devices are performing as specified.

*Response:* NMFS agrees that any TED certified for use in the shrimp fishery should be monitored to ensure proper performance. NMFS Southeast Fisheries Science Center's Harvesting Systems and Engineering Branch works closely with the industry, net manufacturers, observer program, and enforcement to ensure that any problems encountered with the performance of TEDs during fishing conditions is addressed through further gear development and testing. NMFS enforcement will continue to enforce and monitor the TED requirements, including the Coulon TED. However given the anticipated limited use of the Coulon TED, NMFS does not intend to commit extra resources towards monitoring this device.

#### Provisions of the Final Rule

NMFS is issuing a rule allowing the use of an offshore hooped hard TED that

has to meet certain minimum construction standards, in addition to the construction standards specified for hard TEDs generally. The frame for this TED must be made of aluminum rod with a minimum outside diameter of 5/8 inch (1.59 cm) or aluminum tubing with a minimum outside diameter of 1 inch (2.54 cm) and a minimum wall thickness of 1/8 inch (0.32 cm). The escape opening must have a horizontal measurement of no less than 40 inches (102 cm) wide and a forward measurement of no less than 35 inches (89 cm). The front hoop on an offshore hooped hard TED must have an inside horizontal measurement of at least 40 inches (102 cm) and an inside vertical measurement of at least 30 inches (76 cm). The minimum clearance between the deflector bars and the forward edge of the escape opening must be at least 23 1/4 inches (59 cm). The measurement between support bars must be no less than 40 inches (102 cm) (see Figure 1 for illustrations of the offshore hooped hard TED and its dimensions)

**BILLING CODE 3510-22-S**

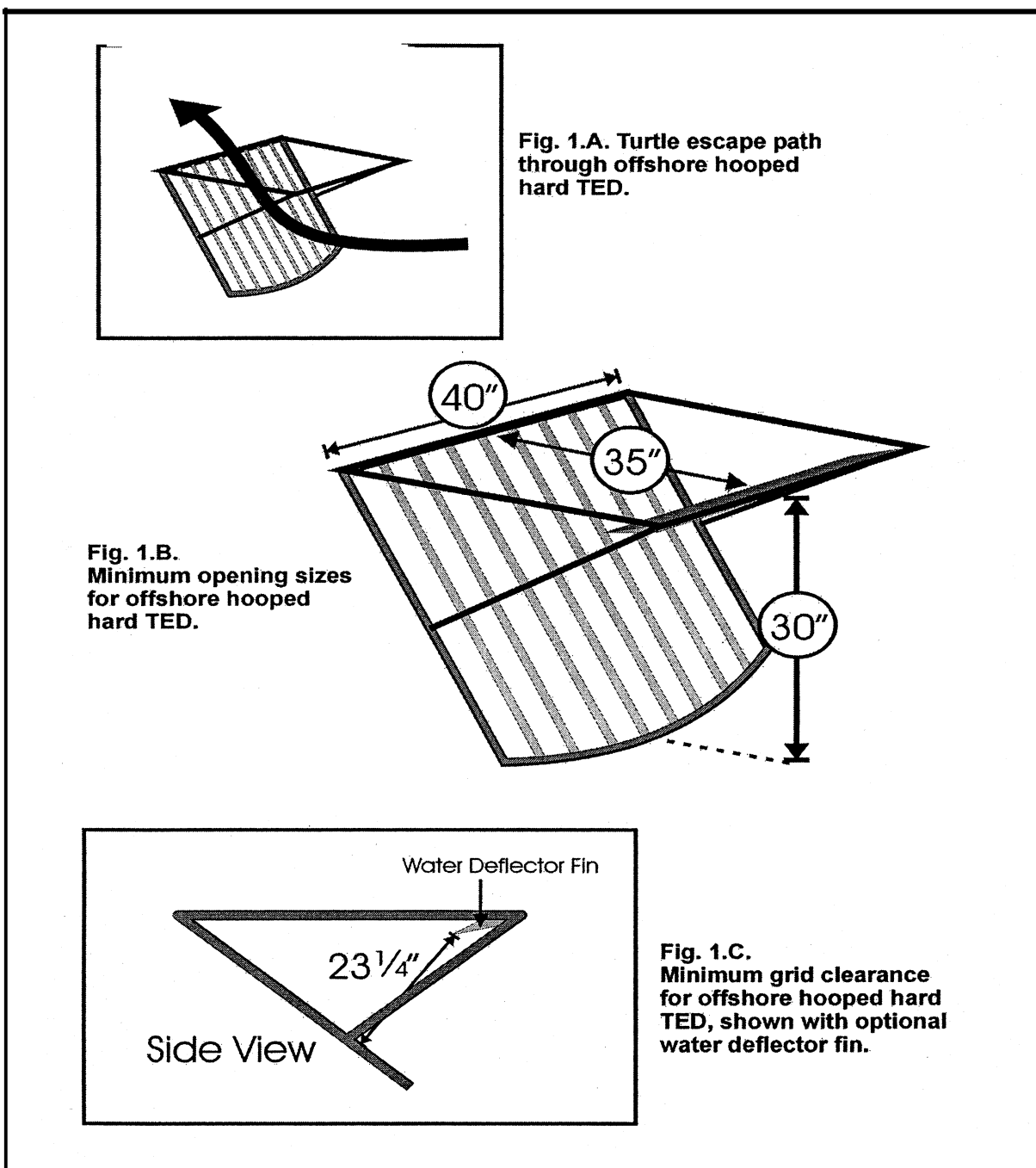

**Figure 1.** Illustration of offshore hooped hard TED dimensions, showing optional water deflector fin.

This final rule will also allow three modifications for hooped hard TEDs. The first is the use of a water deflector fin used to increase shrimp retention. The original Coulon TED design incorporates such a water deflector fin. This fin can be welded onto the forward edge of the escape opening, projecting aft into the TED with an angle of 5 to 45-degrees from the normal, horizontal plane of the trawl. The fin must be constructed of a flat aluminum bar, up to 3/8 inch (0.95 cm) thick and up to 4 inches (10.2 cm) deep. The fin may be as wide as the width of the escape opening, minus 1 inch (2.5 cm).

The second allowable modification is the use of a webbing flap. The resultant escape opening for the offshore hooped hard TED with a webbing flap must have a stretched mesh circumference of no less than 142 inches (361 cm). The end of the flap cannot extend more than 24 inches (61 cm) past the posterior edge of the frame. This is the same webbing flap allowed for use with single-grid hard TEDs with the 71-inch (180 cm) offshore opening (see 50 CFR 223.207(d)(3)(iii)).

The third allowable modification for hooped hard TEDs is the use of a hinged

door frame to partially cover the escape opening. The door frame must be at least as wide as the escape opening, may be up to a maximum of 24 inches (61 cm) long, may be covered with taut mesh webbing (the size of the mesh cannot be greater than that used for the TED extension webbing), and must be connected to the forward edge of the escape opening by a hinge device that will allow the door to open upwards freely. The posterior edge of the door frame, in the closed position, must lie at least 12 inches (30 cm) forward of the posterior edge of the escape opening. If a water deflector fin is used with a hinged door it must be welded to the posterior edge of the door frame, projecting aft into the TED with an angle of 5–45 degrees from the normal, horizontal plane of the trawl. The fin must be constructed of a flat aluminum bar, up to 3/8 inch (0.95 cm) thick and up to four inches (10.2 cm) deep. The fin may be as wide as the width of the escape opening, minus one inch (2.5 cm). The deflector fin must be no less than 12 inches (30 cm) forward of the posterior edge of the escape opening, when the door is in the closed position. Two stopper ropes or a hinge limiter

may be used to limit the maximum opening height of the hinged door frame, as long as the minimum clearance between any part of the deflector bars and any part of the door, including a water deflector fin if installed, in its fully open position is at least 23 1/4 inches (59 cm) for an offshore hooped hard TED or at least 20 inches (51 cm) for an inshore hooped hard TED. The purpose of the stopper ropes or hinge limiters is to prevent the door frame from opening excessively during net deployment and haulback, possibly resulting in loss of catch or damage to the door. Any stopper ropes or hinge limiters must not restrict the free operation of the door, up to its maximum opening (i.e. the door must be able to easily swing to the required opening height before the stops or limiters affect its movement). The hinged door cannot be used in combination with a webbing flap or with a water deflector fin attached to the forward edge of the escape opening (See Figure 2 for illustration of the optional hinged door frame, shown with water deflector fin).

**BILLING CODE 3510-22-S**

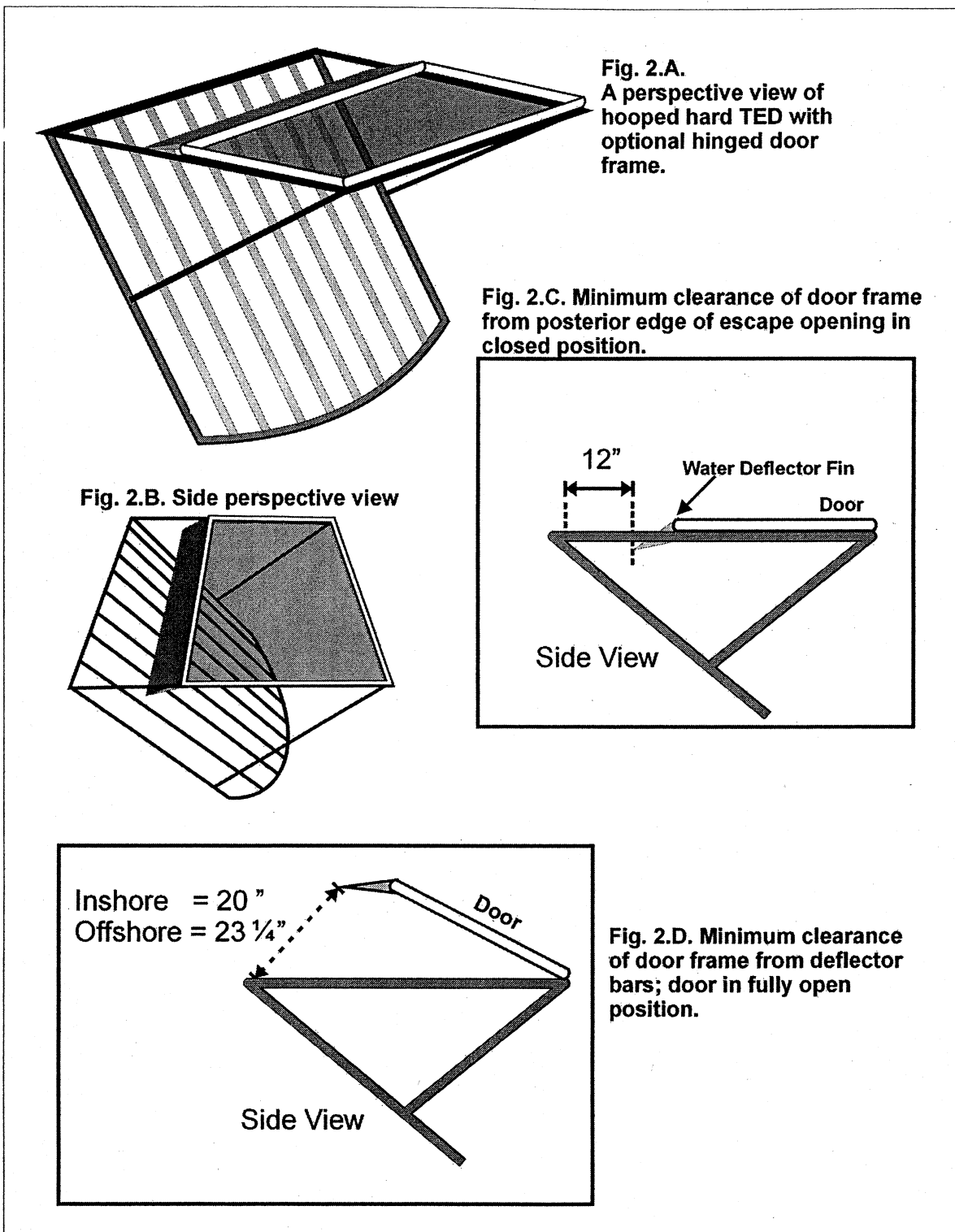

**Figure 2.** Hooped hard TED with optional hinged door frame and water deflector fin.

**Classification**

This final rule has been determined to be not significant for purposes of Executive Order 12866.

NMFS prepared an environmental assessment (EA) for this final rule that evaluates the potential impact on the environment that may result from the final rule. The EA found that the implementation of this final rule will not have a significant impact on the quality of the human environment and that the preparation of an environmental impact statement is not necessary. A copy of the EA is available from NMFS (see ADDRESSES).

Under the existing TED regulations published on February 21, 2003, offshore fishermen can choose to use a single grid hard TED with either a 71-inch (180-cm) opening or a double cover flap, or they can use a Parker soft TED with a leatherback opening. Until this final rule becomes effective, hooped hard TED use would not be legal in offshore waters. Accordingly, if the effectiveness of this rule is delayed, it would burden fishermen who currently use hooped hard TEDS in offshore waters and plan to continue using them by forcing them either to abstain from fishing until the rule becomes effective, or else purchase an additional TED of one of the varieties described above. If the rule becomes effective immediately, then there will be no need for such substantial duplicative expenditures in order to fish during that period. Therefore, because this rule relieves a restriction, the Assistant Administrator for Fisheries, NOAA, finds good cause under the Administrative Procedure Act pursuant to 5 U.S.C. 553(d)(1) to waive the 30 day delay in effectiveness for this final rule.

The Endangered Species Act provides the statutory basis for this final rule.

The Chief Counsel for Regulation of the Department of Commerce certified to the Chief Counsel for Advocacy of the Small Business Administration that this final rule, if adopted, would not have a significant economic impact on a substantial number of small entities. This final rule, if adopted, will not have a significant economic impact on a substantial number of small entities because the provisions of the final rule would not require any action or purchase on the part of fishermen, but rather would allow fishermen the option of a hooped hard TED design to comply with the TED requirement. Hooped hard TEDs are already in use by some fishermen who prefer this TED style due to its efficiency in releasing both turtles and fish bycatch, while retaining

shrimp. Therefore, a regulatory flexibility analysis was not prepared.

**List of Subjects in 50 CFR Part 223**

Endangered and threatened species, Exports, Imports, Marine mammals, Transportation.

Dated: August 21, 2003.

**Rebecca Lent,**

*Deputy Assistant Administrator for Regulatory Programs, National Marine Fisheries Service.*

■ For the reasons set out in the preamble, 50 CFR part 223 will be amended as follows:

**PART 223—THREATENED MARINE AND ANADROMOUS SPECIES**

■ 1. The authority citation for part 223 continues to read as follows:

**Authority:** 16 U.S.C. 1531 *et seq.*

■ 2. In § 223.207, paragraphs (a) introductory text, (a)(1), (a)(7)(i), and (a)(8)(i) are revised and paragraphs (d)(6) and (d)(7) are added to read as follows:

**§ 223.207 Approved TEDs.**

(a) *Hard TEDs.* Hard TEDs are TEDs with rigid deflector grids and are categorized as “hooped hard TEDs” and “single-grid hard TEDs” such as the Matagorda and Georgia TED (Figures 3 & 4 to this part). Hard TEDs complying with the following generic design criteria are approved TEDs:

(1) *Construction materials*—(i) *Single-grid and inshore hooped hard TED.* A single-grid hard TED or an inshore hooped hard TED must be constructed of one or a combination of the following materials, with minimum dimensions as follows:

(A) Solid steel rod with a minimum outside diameter of 1/4 inch (0.64 cm);

(B) Fiberglass or aluminum rod with a minimum outside diameter of 1/2 inch (1.27 cm); or

(C) Steel or aluminum tubing with a minimum outside diameter of 1/2 inch (1.27 cm) and a minimum wall thickness of 1/8 inch (0.32 cm) (also known as schedule 40 tubing).

(ii) *Offshore hooped hard TED.* An offshore hooped hard TED must be constructed of aluminum, with minimum dimensions as follows:

(A) Solid rod with a minimum outside diameter of 5/8 inch (1.59 cm); or

(B) Tubing with a minimum outside diameter of 1 inch (2.54 cm) and a minimum wall thickness of 1/8 inch (0.32 cm).

\* \* \* \* \*

(7) \* \* \*

(i) *Hooped hard TEDs.* \* \* \*

(A) *Escape opening for inshore hooped hard TED.* The inshore hooped

hard TED escape opening must have a horizontal measurement of no less than 35 inches (89 cm) wide and a forward measurement of no less than 27 inches (69 cm). A hinged door frame may be used to partially cover the escape opening as provided in paragraph (d)(7) of this section. Alternatively, a webbing flap may be used as provided in paragraph (d)(3)(i) of this section. The resultant opening with a webbing flap must be a minimum width of 35 inches (89 cm) and a minimum height of 20 inches (51 cm), with each measurement taken simultaneously. This opening may only be used in inshore waters, except it may not be used in the inshore waters of Georgia and South Carolina.

(B) \ The offshore hooped hard TED escape opening must have a horizontal measurement of no less than 40 inches (102 cm) wide and a forward measurement of no less than 35 inches (89 cm). A hinged door frame may be used to partially cover the escape opening as provided in paragraph (d)(7) of this section. Alternatively, a webbing flap may be used as provided in paragraph (d)(3)(ii) of this section. The resultant escape opening with a webbing flap must have a stretched mesh circumference of no less than 142 inches (361 cm).

\* \* \* \* \*

(8) \* \* \*

(i) *Hooped hard TEDs.*

(A) *Inshore hooped hard TED.* The front hoop on an inshore hooped hard TED must have an inside horizontal measurement of at least 35 inches (89 cm) and an inside vertical measurement of at least 30 inches (76 cm). The minimum clearance between the deflector bars and the forward edge of the escape opening must be at least 20 inches (51 cm).

(B) *Offshore hooped hard TED.* The front hoop on an offshore hooped hard TED must have an inside horizontal measurement of at least 40 inches (102 cm) and an inside vertical measurement of at least 30 inches (76 cm). The minimum clearance between the deflector bars and the forward edge of the escape opening must be at least 23 1/4 inches (59 cm).

\* \* \* \* \*

(d) \* \* \*

(6) *Water deflector fin for hooped hard TEDs.* On a hooped hard TED, a water deflector fin may be welded to the forward edge of the escape opening. The fin must be constructed of a flat aluminum bar, up to 3/8 inch (0.95 cm) thick and up to 4 inches (10.2 cm) deep. The fin may be as wide as the width of the escape opening, minus 1 inch (2.5 cm). The fin must project aft into the

TED with an angle between 5° and 45° from the normal, horizontal plane of the trawl. On an inshore hooped hard TED, the clearance between the deflector bars and the posterior edge of the deflector fin must be at least 20 inches (51 cm). On an offshore hooped hard TED, the clearance between the deflector bars and the posterior edge of the deflector fin must be at least 23-1/4 inches (59 cm).

(7) *Hinged door frame for hooped hard TEDs.* A hinged door frame may be attached to the forward edge of the escape opening on a hooped hard TED. The door frame must be constructed of materials specified at paragraphs (a)(1)(i) or (a)(1)(ii) of this section for inshore and offshore hooped hard TEDs, respectively. The door frame may be covered with a single panel of mesh webbing that is taut and securely attached with twine to the perimeter of the door frame, with a mesh size not greater than that used for the TED extension webbing. The door frame must be at least as wide as the TED escape opening. The door frame may be a maximum of 24 inches (61 cm) long. The door frame must be connected to the forward edge of the escape opening by a hinge device that allows the door to open outwards freely. The posterior edge of the door frame, in the closed position, must lie at least 12 inches (30 cm) forward of the posterior edge of the escape opening. A water deflector fin may be welded to the posterior edge of the hinged door frame. The fin must be constructed of a flat aluminum bar, up to 3/8 inch (0.95 cm) thick and up to four inches (10.2 cm) deep. The fin may be as wide as the width of the escape opening, minus one inch (2.5 cm). The fin must project aft into the TED with an angle between 5° and 45° from the normal, horizontal plane of the trawl, when the door is in the closed position. The clearance between the posterior edge of the escape opening and the posterior edge of the door frame or the posterior edge of the water deflector fin, if installed, must be no less than 12 inches (30 cm), when the door is in the closed position. Two stopper ropes or a hinge limiter may be used to limit the maximum opening height of the hinged door frame, as long as they do not obstruct the escape opening in any way or restrict the free movement of the door to its fully open position. When the door is in its fully open position, the minimum clearance between any part of the deflector bars and any part of the door, including a water deflector fin if installed, must be at least 20 inches (51 cm) for an inshore hooped hard TED and at least 23 1/4 inches (59 cm) for an offshore hooped hard TED. The hinged

door frame may not be used in combination with a webbing flap specified at paragraph (d)(3) of this section or with a water deflection fin specified at paragraph (d)(6) of this section.

\* \* \* \* \*

[FR Doc. 03-21858 Filed 8-21-03; 5:02 pm]

BILLING CODE 3510-22-S

## DEPARTMENT OF COMMERCE

### National Oceanic and Atmospheric Administration

#### 50 CFR Part 679

[Docket No. 021122286-3036-02; I.D. 082003D]

#### Fisheries of the Exclusive Economic Zone Off Alaska; Pacific Ocean Perch in the Eastern Aleutian District of the Bering Sea and Aleutian Islands

**AGENCY:** National Marine Fisheries Service (NMFS), National Oceanic and Atmospheric Administration (NOAA), Commerce.

**ACTION:** Closure.

**SUMMARY:** NMFS is prohibiting retention of Pacific ocean perch in the Eastern Aleutian District of the Bering Sea and Aleutian Islands (BSAI). NMFS is requiring that catch of Pacific ocean perch in this area be treated in the same manner as prohibited species and discarded at sea with a minimum of injury. This action is necessary because the allocation of the Pacific ocean perch 2003 total allowable catch (TAC) in this area has been achieved.

**DATES:** Effective 1200 hrs, Alaska local time (A.l.t.), August 23, 2003, until 2400 hrs, A.l.t., December 31, 2003.

**FOR FURTHER INFORMATION CONTACT:** Josh Keaton, 907-586-7228.

**SUPPLEMENTARY INFORMATION:** NMFS manages the groundfish fishery in the BSAI exclusive economic zone according to the Fishery Management Plan for the Groundfish Fishery of the Bering Sea and Aleutian Islands (FMP) prepared by the North Pacific Fishery Management Council under authority of the Magnuson-Stevens Fishery Conservation and Management Act. Regulations governing fishing by U.S. vessels in accordance with the FMP appear at subpart H of 50 CFR part 600 and CFR part 679. The allocation of the Pacific ocean perch TAC in the Eastern Aleutian District of the BSAI was established as 3,238 metric tons (mt) by the final 2003 harvest specifications for groundfish in the BSAI and the reserve apportionment (68 FR 9907, March 3,

2003). The allocation of Pacific ocean perch TAC in the Eastern Aleutian District of the BSAI to Community Development Quota (CDQ) participants was established as 263 mt by the final 2003 harvest specifications for groundfish in the BSAI.

In accordance with § 679.20(d)(2), the Administrator, Alaska Region, NMFS, has determined that the allocation of the Pacific ocean perch TAC in the Eastern Aleutian District of the BSAI has been reached. Therefore, NMFS is requiring that further catches of Pacific ocean perch TAC in the Eastern Aleutian District of the BSAI be treated as prohibited species in accordance with § 679.21(b).

As of August 19, 2003, 125 mt of the Pacific ocean perch CDQ reserve in the Eastern Aleutian District of the BSAI remains unharvested. Therefore, CDQ participants are not yet required to treat catch of Pacific ocean perch in the Eastern Aleutian District of the BSAI as a prohibited species.

#### Classification

This action responds to the best available information recently obtained from the fishery. The Assistant Administrator for Fisheries, NOAA (AA), finds good cause to waive the requirement to provide prior notice and opportunity for public comment pursuant to the authority set forth at 5 U.S.C. 553(b)(B) as such requirement is contrary to the public interest. This requirement is contrary to the public interest as it would delay the prohibition of retention, lead to exceeding the TAC of Pacific ocean perch in the Eastern Aleutian District of the BSAI, and therefore reduce the public's ability to use and enjoy the fishery resource.

The AA also finds good cause to waive the 30-day delay in the effective date of this action under 5 U.S.C. 553(d)(3). This finding is based upon the reasons provided above for waiver of prior notice and opportunity for public comment.

This action is required by § 679.20 and is exempt from review under Executive Order 12866.

**Authority:** 16 U.S.C. 1801 *et seq.*

Dated: August 21, 2003.

**Bruce C. Morehead,**

*Acting Director, Office of Sustainable Fisheries, National Marine Fisheries Service.*

[FR Doc. 03-21933 Filed 8-22-03; 2:45 pm]

BILLING CODE 3510-22-S