

The request should include an assessment of the effect of the modification, alteration, or repair on the unsafe condition addressed by this AD; and if the unsafe condition has not been eliminated, the request should include specific proposed actions to address it.

Compliance: Required within 200 hours time-in-service, unless accomplished previously.

To prevent a fire in the engine compartment from reaching the main gearbox (MGB) compartment that contains parts that are not fire resistant and subsequent loss of control of the helicopter, accomplish the following:

(a) Replace the MGB opening neoprene cowling seals with glass/silicone seals in accordance with the Accomplishment Instructions, paragraph 2.B., of Eurocopter Alert Service Bulletin No. 53.00.31, dated July 11, 2002.

(b) Replacing the MGB opening neoprene cowling seals with glass/silicone seals is terminating action for the requirements of this AD.

(c) An alternative method of compliance or adjustment of the compliance time that provides an acceptable level of safety may be used if approved by the Manager, Regulations Group, Rotorcraft Directorate, FAA. Operators shall submit their requests through an FAA Principal Maintenance Inspector, who may concur or comment and then send it to the Manager, Regulations Group.

Note 2: Information concerning the existence of approved alternative methods of compliance with this AD, if any, may be obtained from the Regulations Group.

(d) Special flight permits may be issued in accordance with 14 CFR 21.197 and 21.199 to operate the helicopter to a location where the requirements of this AD can be accomplished.

Note 3: The subject of this AD is addressed in Direction Generale De L'Aviation Civile (France), AD 2002-537-094(A), dated October 30, 2002.

Issued in Fort Worth, Texas, on April 15, 2003.

David A. Downey,

Manager, Rotorcraft Directorate, Aircraft Certification Service.

[FR Doc. 03-9863 Filed 4-21-03; 8:45 am]

BILLING CODE 4910-13-P

DEPARTMENT OF TRANSPORTATION

Federal Aviation Administration

14 CFR Part 39

[Docket No. 2000-SW-12-AD]

RIN 2120-AA64

Airworthiness Directives; Eurocopter France Model AS350B, B1, B2, B3, BA, C, D, D1, and AS355E, F, F1, F2, and N Helicopters

AGENCY: Federal Aviation Administration, DOT.

ACTION: Supplemental notice of proposed rulemaking; reopening of comment period.

SUMMARY: This document revises an earlier proposed airworthiness directive (AD) for the specified Eurocopter France (ECF) model helicopters that proposed a daily inspection of the tail rotor pitch control rod (control rod) outboard spherical bearing (bearing), a radial and axial play limit, a revised AD compliance interval, and adding the ECF Model AS350B3 helicopter and an additional control rod to the applicability. That proposal was prompted by two comments received and the FAA determination that the AD inspection interval should coincide with the normal maintenance interval and that the AD should apply to the ECF Model AS350B3 helicopter. This action retains the original proposals but changes the daily inspection to a daily check and makes other editorial changes for clarification. The actions specified by the proposed AD are intended to prevent separation of the bearing ball from its outer race, rubbing of the body of the control rod against the tail rotor blade pitch horn clevis, failure of the control rod, and subsequent loss of control of the helicopter.

DATES: Comments must be received on or before June 23, 2003.

ADDRESSES: Submit comments in triplicate to the Federal Aviation Administration (FAA), Office of the Regional Counsel, Southwest Region, Attention: Rules Docket No. 2000-SW-12-AD, 2601 Meacham Blvd., Room 663, Fort Worth, Texas 76137. You may also send comments electronically to the Rules Docket at the following address: 9-asw-adcomments@faa.gov. Comments may be inspected at the Office of the Regional Counsel between 9 a.m. and 3 p.m., Monday through Friday, except Federal holidays.

FOR FURTHER INFORMATION CONTACT: Uday Garadi, Aviation Safety Engineer, FAA, Rotorcraft Directorate, Rotorcraft Standards Staff, Fort Worth, Texas 76193-0110, telephone (817) 222-5123, fax (817) 222-5961.

SUPPLEMENTARY INFORMATION:

Comments Invited

Interested persons are invited to participate in the making of the proposed rule by submitting such written data, views, or arguments as they may desire. Communications should identify the Rules Docket number and be submitted in triplicate to the address specified above. All communications received on or before the closing date for comments, specified

above, will be considered before taking action on the proposed rule. The proposals contained in this document may be changed in light of the comments received.

Comments are specifically invited on the overall regulatory, economic, environmental, and energy aspects of the proposed rule. All comments submitted will be available, both before and after the closing date for comments, in the Rules Docket for examination by interested persons. A report summarizing each FAA-public contact concerned with the substance of this proposal will be filed in the Rules Docket.

Commenters wishing the FAA to acknowledge receipt of their mailed comments submitted in response to this proposal must submit a self-addressed, stamped postcard on which the following statement is made: "Comments to Docket No. 2000-SW-12-AD." The postcard will be date stamped and returned to the commenter.

Discussion

On November 19, 1998, the FAA issued AD 98-24-35, Amendment 39-10921, Docket 98-SW-41-AD (63 FR 66418, December 2, 1998), to require measuring the control rod bearing radial and axial play every 50 hours time-in-service (TIS). That action was prompted by an accident and an incident involving ECF Model AS350B2 helicopters. There were two other unconfirmed incidents cited by the National Transportation Safety Board (based on manufacturer's reports) involving the same control rod, part number (P/N) 350A33-2145-00.

After issuing AD 98-24-35, ECF issued Service Letter No. 1367-64-98, dated January 12, 1999, to provide operators with an easy way to determine the looseness of the bearing by adding an axial play limit of 0.016 inch and a daily check. When the FAA issued AD 98-24-35, neither the Direction Generale De L'Aviation Civile nor the manufacturer had issued any service information addressing this unsafe condition.

Subsequently, the FAA received comments from two commenters, the manufacturer and an operator, stating that a larger axial play limit and a 30-hour time-in-service (TIS) visual check would provide a satisfactory degree of safety for this control rod and an adequate inspection interval.

The FAA agreed and issued a proposal to amend 14 CFR part 39, published as an NPRM in the **Federal Register** on April 9, 2001 (66 FR 18416), to supersede AD 98-24-35. The NPRM

proposed adding ECF Model AS350B3 helicopters and control rod, P/N 350A33-3145-00, to the applicability; increasing the frequency of the inspection interval from every 50 hours TIS to every 30 hours TIS; establishing a daily inspection of the control rod bearing; and establishing an axial play limit of 0.016-inch. The actions of that proposed AD were intended to prevent separation of the bearing ball from its outer race, rubbing of the body of the control rod against the tail rotor blade pitch horn clevis, failure of the control rod, and subsequent loss of control of the helicopter.

Since issuing that NPRM, the FAA has received various comments from 12 commenters.

Three commenters state that the proposed daily inspection of the bearing should be deleted because the requirement already exists in the maintenance work cards and in the preflight checklist in the rotorcraft flight manual (RFM). In addition, another commenter states that the daily inspection should be changed to a daily check and that a trained pilot should do the check. The FAA agrees that a pilot can do the check but believes that due to the accidents caused by failure of the control rods and because the RFM and the maintenance work cards are unclear a daily check should be required. However, we are revising our proposal to allow an owner/operator (pilot) to perform the daily check of the bearing for movement because no tools are required and the check can be accomplished by observation and feel. However, the pilot must enter compliance with those requirements into the helicopter maintenance records in accordance with 14 CFR 43.11 and 91.417(a)(2)(v).

One commenter, the manufacturer, states that the control rod P/N is incorrectly stated in three places. Also, in its Service Letter No. 1367-64-98, which details the most effective checking conditions, the term "easy" is more suitable than the term "accurate" as used in the proposed AD. The FAA agrees and has made those changes as requested.

The manufacturer requests that the proposed Figures 1 and 2, relating to the axial and radial play measurements, be replaced with three clearer figures provided by them. The FAA agrees. Published Figure 1 gives the method only for a visual check. Published Figure 2 shows the complete assembly of the control rod and makes it appear that the measurements can be made without removing the control rod from the helicopter. Therefore, the FAA is inserting the three clearer figures in the

proposal to clearly depict the measurement of radial and axial play and is including references in the text accordingly.

Seven commenters state that the inspection interval of the bearing should be changed from the proposed 30 to 100 hours TIS. One commenter states that the inspection interval should not be less than 50 hours TIS. The FAA mistakenly proposed an inspection of all affected control rods at intervals not to exceed 30 hours TIS. The 30-hour TIS inspection interval was intended to apply only to the control rods that were removed from the helicopter because play was detected, not to newly installed or in-service control rods. Therefore, we have changed the proposed paragraph numbering and added the word "thereafter" to clearly indicate that the 30-hour TIS inspection interval applies to control rods in which play has been detected. We do not agree that the inspection interval for these control rods should be extended above 30 hours TIS.

The manufacturer further states that the compliance time in paragraph (a) should be changed from "before the first flight" (BFF) to "after the last flight" (ALF) of the day. The commenter states that if maintenance is required for operational reasons, ALF is preferable to BFF because the mechanic has more time to do the work and states that the ALF visit is longer and a more important daily visit compared with the BFF. The FAA does not agree. The intent is to check the helicopter for safety of flight in accordance with the requirements of this AD regardless of whether it is done ALF or BFF.

The manufacturer further states that we should add a requirement that if the ball shows evidence of scoring and/or discoloration, the control rod should be replaced with an airworthy control rod before further flight. The FAA agrees and has changed the wording of the proposed AD to state that if discoloration or scoring on the bearing is found, the bearing is unairworthy.

Another commenter with 20 years of experience with these helicopters states that neither the current AD nor this proposed AD is needed. The FAA disagrees. The FAA has determined that an AD is required based on the occurrence of accidents due to failure of these control rods.

One commenter fully agrees with the proposal and suggests adding a warning to the RFM alerting pilots that violent vibration due to a pitch control rod failure will result in separation of the tail boom. The FAA disagrees. The RFM Emergency Procedures address the tail rotor malfunction including tail rotor

control failure. The daily check should preclude any impending failure of the control rod based on the conditions addressed by this AD.

Other commenters agree with the proposal to increase the axial play from .008 inch to .016 inch; however, one commenter asks if leaving the allowable play at .008 inch would not be safer. The FAA believes that a sufficient margin of safety is provided if the play is increased to .016 inch.

On July 10, 2002, the FAA issued a new version of 14 CFR part 39 (67 FR 47997, July 22, 2002), which governs the FAA's AD system. The regulation now includes material that relates to altered products, special flight permits, and alternative methods of compliance. Because we have now included this material in part 39, we no longer need to include it in each individual AD. Therefore, Notes 1 and 2 and paragraph (c) as published in AD 98-24-35 and the NPRM in this action are not included in this supplemental notice of proposed rulemaking. However, a revised paragraph (c) is added to the proposed action.

Some of these changes expand the scope of the originally proposed rule. Therefore, the FAA has determined that it is necessary to reopen the comment period to provide additional opportunity for public comment.

The FAA estimates that the AD would affect 610 helicopters of U.S. registry, that it would take approximately 1 work hour per helicopter to accomplish the inspections, and that the average labor rate is \$60 per work hour. Required parts would cost approximately \$1,224 for two control rods per helicopter. Based on these figures, the total cost impact of the proposed AD on U.S. operators is estimated to be \$783,240.

The regulations proposed herein would not have a substantial direct effect on the States, on the relationship between the national government and the States, or on the distribution of power and responsibilities among the various levels of government. Therefore, it is determined that this proposal would not have federalism implications under Executive Order 13132.

For the reasons discussed above, I certify that this proposed regulation (1) is not a "significant regulatory action" under Executive Order 12866; (2) is not a "significant rule" under the DOT Regulatory Policies and Procedures (44 FR 11034, February 26, 1979); and (3) if promulgated, will not have a significant economic impact, positive or negative, on a substantial number of small entities under the criteria of the Regulatory Flexibility Act. A copy of the draft regulatory evaluation prepared for this

action is contained in the Rules Docket. A copy of it may be obtained by contacting the Rules Docket at the location provided under the caption **ADDRESSES**.

List of Subjects in 14 CFR Part 39

Air transportation, Aircraft, Aviation safety, Safety.

The Proposed Amendment

Accordingly, pursuant to the authority delegated to me by the Administrator, the Federal Aviation Administration proposes to amend 14 CFR part 39 as follows:

PART 39—AIRWORTHINESS DIRECTIVES

1. The authority citation for part 39 continues to read as follows:

Authority: 49 U.S.C. 106(g), 40113, 44701.

§ 39.13 [Amended]

2. Section 39.13 is amended by adding a new airworthiness directive to read as follows:

Eurocopter France: Docket No. 2000–SW–12–AD.

Applicability: Eurocopter France Model AS350B, B1, B2, B3, BA, C, D, D1, and AS355E, F, F1, F2, and N helicopters, with tail rotor pitch control rod (control rod), part number (P/N) 350A33–2145–00 or 350A33–

2145–01, installed, certificated in any category.

Compliance: Required as indicated, unless accomplished previously.

To prevent separation of the control rod outboard spherical bearing (bearing) ball from its outer race, rubbing of the body of the control rod against the tail rotor blade pitch horn clevis, failure of the control rod, and subsequent loss of control of the helicopter, accomplish the following:

(a) Before the first flight of each day, place the tail rotor pedals in the neutral position. If the helicopter is fitted with a tail rotor load compensator, discharge the accumulator as described in the rotorcraft flight manual. Check the bearing for play on the helicopter, by observation and feel, by slightly moving the tail rotor blade in the flapping axis while monitoring the bearing for movement. See the following Figure 1 of this AD:

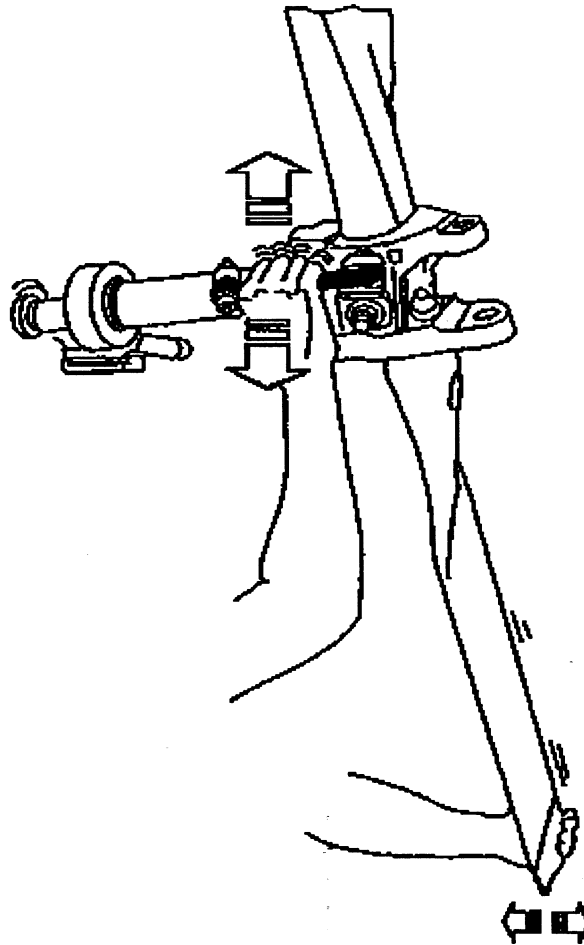

Figure 1: Manual Check for Play of the Tail Rotor Pitch Control Rod

(1) If the Teflon cloth is coming out of its normal position within the bearing, totally or partially, or if there is discoloration or scoring on the bearing, the bearing is unairworthy.

(2) An owner/operator (pilot) holding at least a private pilot certificate may perform this check and must enter compliance into the aircraft maintenance records in accordance with 14 CFR 43.11 and 91.417(a)(2)(v).

(b) If a pilot or mechanic detects play, a mechanic must remove the control rod from the helicopter, and using a dial indicator, measure the bearing wear according to the following and as shown in Figures 2 and 3 of this AD:

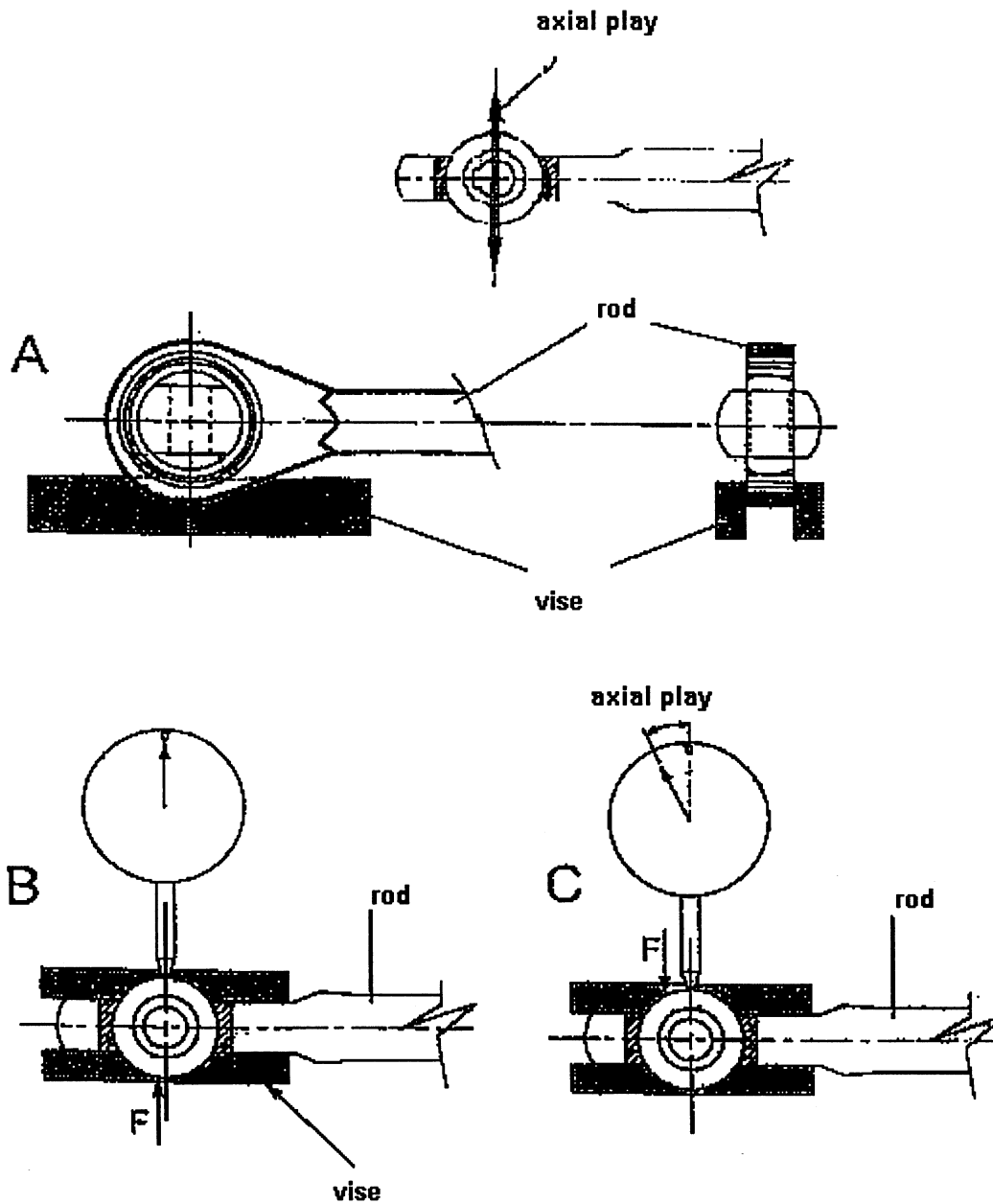

Figure 2: Measurement of the Axial Play (A) of the Bearing

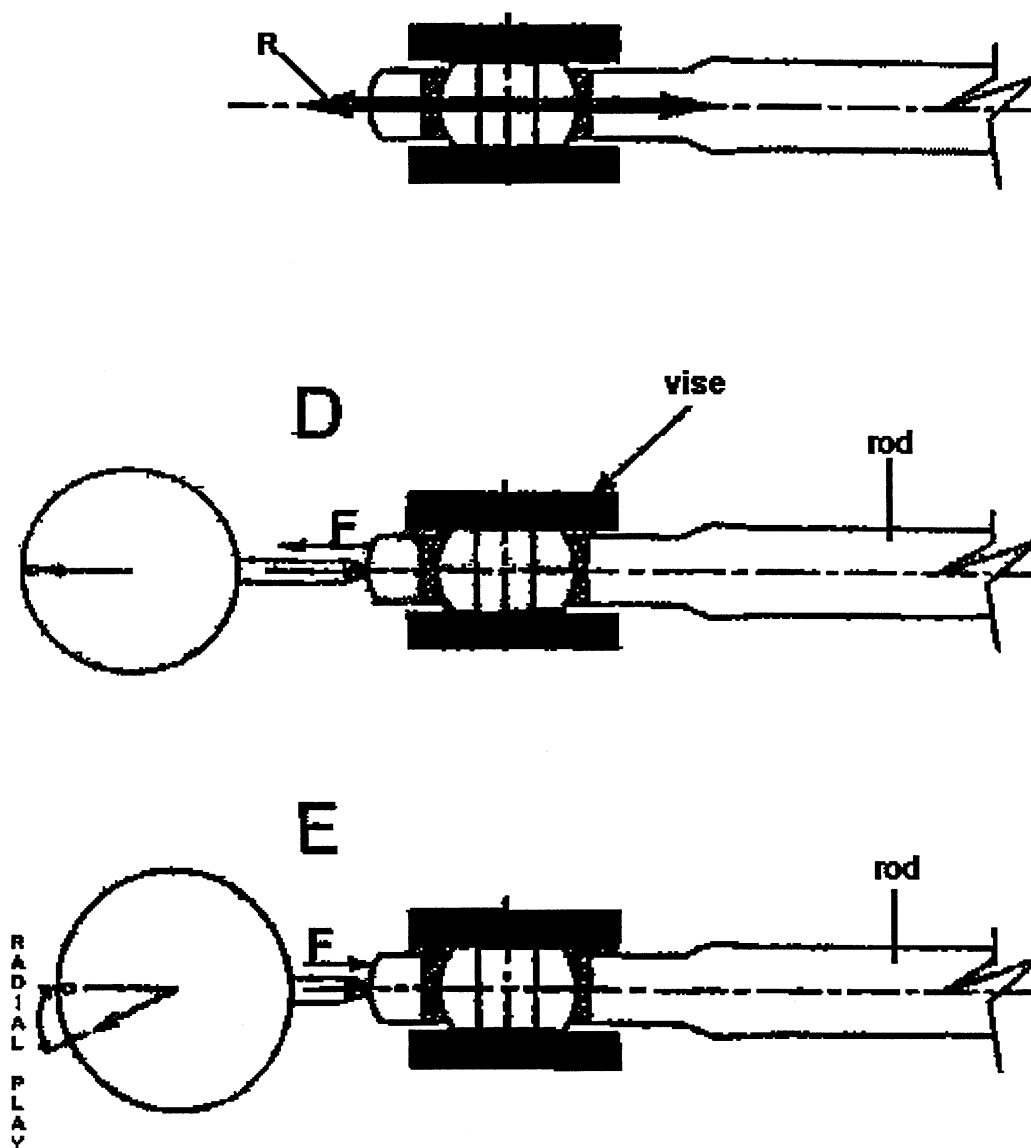

Figure 3: Measurement of the Radial Play (R) of the Bearing

(1) Remove the control rod from the helicopter.

(2) Mount the control rod in a vise as shown in Figure 2 of this AD.

(3) Using a dial indicator, take axial play readings by moving the spherical bearing in the direction F (up and down) as shown in Figure 2 of this AD.

(4) Install a bolt washer and nut to secure the bearing after removing it from the vise.

(5) Mount the bearing in a vise as shown in Figure 3 of this AD.

(6) Using a dial indicator, take radial play measurements by moving the control rod in the direction F as shown in Figure 3 of this AD.

(7) Record the hours of operation on each control rod.

(8) If the radial play exceeds 0.008 inch or axial play exceeds 0.016 inch, replace the

control rod with an airworthy control rod before further flight.

(9) If the radial and axial play are within limits, reinstall the control rod.

(10) Thereafter, at intervals not to exceed 30 hours TIS, remove the control rod and again measure the bearing play with a dial indicator in accordance with this paragraph.

(c) To request a different method of compliance or a different compliance time for this AD, follow the procedures in 14 CFR

39.19. Contact the Manager, Regulations Group, Rotorcraft Directorate, FAA, for information about previously approved alternative methods of compliance.

Issued in Fort Worth, Texas, on April 15, 2003.

David A. Downey,

Manager, Rotorcraft Directorate, Aircraft Certification Service.

[FR Doc. 03-9862 Filed 4-21-03; 8:45 am]

BILLING CODE 4910-13-P

DEPARTMENT OF HEALTH AND HUMAN SERVICES

Food and Drug Administration

21 CFR Chapter I

[Docket No. 02N-0434]

Withdrawal of Certain Proposed Rules and Other Proposed Actions; Notice of Intent

AGENCY: Food and Drug Administration, HHS.

ACTION: Notice of intent.

SUMMARY: The Food and Drug Administration (FDA) is announcing its intent to withdraw certain advance notice of proposed rulemakings (ANPRMs), proposed rules, and other proposed actions that published in the **Federal Register** more than 5 years ago. These proposals rules are no longer considered viable candidates for final action at this time. FDA is taking this action to reduce its regulatory backlog and focus its resources on current public health issues. The FDA's actions are part of an overall regulatory reform strategy initiated by HHS Secretary Tommy G. Thompson.

DATES: Submit written or electronic comments by July 21, 2003.

ADDRESSES: Submit written comments to the Dockets Management Branch (HFA-305), Food and Drug Administration, 5630 Fishers Lane, rm. 1061, Rockville, MD 20852. Submit electronic comments to <http://www.fda.gov/dockets/ecomments>.

FOR FURTHER INFORMATION CONTACT: Lisa M. Helmanis, Regulations Policy and Management Staff (HF-26), Food and Drug Administration, 5600 Fishers Lane, Rockville, MD 20857, 301-827-3480.

SUPPLEMENTARY INFORMATION: On June 8, 2001, Secretary Thompson announced his regulatory reform initiative designed to reduce regulatory burdens in health care and respond faster to the concerns of health care providers, State, and local governments and individual Americans who are affected by HHS rules. In

December of 2001 the Secretary announced the membership of his Regulatory Reform Committee designed to carry out his initiative. In November of 2002 the Committee released its final report with over 255 specific recommendations for simplifying, streamlining and generally reducing the regulatory burden while continuing to require accountability by those doing business with HHS and its agencies. Over 25 of the recommendations have been adopted and the Secretary charged the Office of the Assistant Secretary for Planning and Evaluation to continue the efforts of the Regulatory Reform Committee. FDA's continuing efforts to withdraw regulations that have been proposed but not finalized are part of this overall initiative.

I. Background

In 1990, FDA began a comprehensive review of its regulations process that included a review of the backlog of advance notices of proposed rulemaking, notices of proposed rulemaking, and other notices for which no final action or withdrawal notice had been issued. In the **Federal Register** of August 28, 1991 (56 FR 42668), FDA announced its intent to withdraw 115 proposed rules published before December 31, 1985, that had never been finalized and invited comment on its intent. In the **Federal Register** of December 30, 1991 (56 FR 67440), FDA issued its first notice withdrawing 89 of those outstanding proposed rules. Again, in the **Federal Register** of January 19, 1993 (58 FR 4953), FDA announced its intent to withdraw 10 proposed rules that had never been finalized and invited comment on its intent. In the **Federal Register** of January 20, 1994 (59 FR 3042), the agency withdrew an additional 9 outstanding proposed rules.

Once again, FDA has reviewed its pending proposed rules and other notices that published in the **Federal Register** more than 5 years ago, and for which no final rule or notice of withdrawal has been issued. The agency has identified 84 such proposed rules and other actions that should be formally withdrawn. Included in this current list are 19 proposed rules that were included in the original 1991 list, but at that time, the agency decided to defer its decision to withdraw or finalize them until a later date. As with the other proposals it intends to withdraw, FDA believes that it is no longer appropriate to continue these rulemakings. These 19 proposed rules are identified in table 1 of this document.

As with the 1991 review, the agency undertook this most recent review because it believes that the backlog of pending proposals dilutes its ability to concentrate on higher priority regulations that are mandated by statute or necessary to address current public health issues. Because of the agency's limited resources and changing priorities, FDA has been unable to consider, in a timely manner, the issues raised by the comments on these proposals and either complete the action on them or withdraw the proposals. Additionally, because many of the proposals have become outdated in the time that has elapsed since their publication, the agency would need to obtain further comment on them before proceeding to final action. FDA has determined that the proposals identified in this document are lower in priority than those on the Unified Agenda and the Regulatory Plan. It is unlikely that the agency will have sufficient resources in the foreseeable future to further consider or prioritize these proposed rules. Although not required to do so by the Administrative Procedure Act or by regulations of the Office of the Federal Register, the agency believes the public interest is best served by withdrawing these 84 proposals. In some instances, the agency has already completed action on alternatives, e.g., the issuance of guidance or inclusion of provisions in related regulations, that have obviated the need to complete the proposed action.

If the agency does withdraw these proposals, that action would not preclude the agency from reinstating proceedings to issue rules concerning the issues addressed in the proposals listed in table 1 of this document. Should FDA decide to undertake such a rulemaking sometime in the future, it will re-propose the actions and provide new opportunities for comment. For some proposals, the agency already has plans to institute new proceedings. Further, interested persons may submit a citizen petition requesting that the agency initiate rulemaking on any of the issues covered by the proposed rules that FDA intends to withdraw.

The agency advises that in some cases the preambles of these proposals may still reflect the current position of FDA on the matter addressed. In addition, withdrawal of a proposal is not intended to affect whatever utility the preamble statements may currently have as indications of FDA's position on a matter at the time the proposal was published.

Therefore, for the reasons set forth previously, and under the Federal Food, Drug, and Cosmetic Act, the agency