



Federal Register

**Friday,
December 27, 2002**

Part IV

Department of Transportation

**National Highway Traffic Safety
Administration**

**49 CFR Part 571
Federal Motor Vehicle Safety Standards;
Platform Lift Systems for Accessible
Motor Vehicles, Platform Lift Installation
on Motor Vehicles; Final Rule**

DEPARTMENT OF TRANSPORTATION

National Highway Traffic Safety Administration

49 CFR Part 571

[Docket No. NHTSA-02-13917; Notice 1]

RIN 2127-AD50

Federal Motor Vehicle Safety Standards; Platform Lift Systems for Accessible Motor Vehicles, Platform Lift Installations on Motor Vehicles

AGENCY: National Highway Traffic Safety Administration (NHTSA), Department of Transportation.

ACTION: Final rule.

SUMMARY: This document adopts a new rule establishing two new safety standards: An equipment standard specifying requirements for platform lifts; and a vehicle standard for all vehicles equipped with such lifts. The new equipment standard will require platform lift manufacturers to ensure that their lifts meet minimum platform dimensions and maximum size limits on platform protrusions and gaps between the platform and either the vehicle floor or the ground. The standard also requires handrails, a threshold warning signal, and retaining barriers for lifts. Performance tests are specified for wheelchair retention on the platform, lift strength, and platform slip resistance. A set of interlocks is prescribed to prevent accidental movement of a lift and the vehicle on which the lift is installed. The vehicle standard will require vehicle manufacturers who install lifts to use lifts meeting the equipment standard, to install them in accordance with the lift manufacturer's instructions, and to ensure that specific information is made available to lift users. The purpose of the two standards is to prevent injuries and fatalities during lift operation and to promote the uniformity of Federal standards and guidelines for platform lifts.

DATES: *Effective Date:* This rule is effective December 27, 2004.

The incorporation by reference of the publications listed in the rule is approved by the Director of the Federal Register as of December 27, 2004.

Petitions: Petitions for reconsideration must be received by February 10, 2003.

ADDRESSES: Petitions for reconsideration should refer to the docket and notice number of this document and be submitted to: Administrator, National Highway Traffic Safety Administration, 400 Seventh Street, SW., Washington, DC 20590.

FOR FURTHER INFORMATION CONTACT: For non-legal issues, you may call William Evans, Office of Crash Avoidance Standards, at (202) 366-2272.

For legal issues, you may call Rebecca MacPherson, Office of the Chief Counsel, at (202) 366-2992.

You may send mail to both of these officials at National Highway Traffic Safety Administration, 400 Seventh St., SW., Washington, DC 20590.

SUPPLEMENTARY INFORMATION:**Table of Contents**

- I. Background
- II. Summary of the SNPRM
- III. Summary of the final rule and key differences between it and the SNPRM
 - A. Manufacturer responsibilities under the final rule
 - 1. Platform lift manufacturers
 - 2. Vehicle manufacturers
 - B. Platform lift requirements
- IV. Summary of public comments
- V. Need for safety standards for platform life systems
- VI. Differing safety needs for private and public use platform lifts
- VII. Effective dates
- VIII. Platform lift requirements
 - A. Threshold warning signal
 - B. Platform lift operational requirements
 - 1. Maximum platform velocity
 - 2. Maximum platform acceleration
 - 3. Maximum noise level of public use lifts
 - C. Environmental resistance
 - D. Platform requirements
 - 1. Unobstructed platform operating volume
 - 2. Platform surface protrusions
 - 3. Gaps, transitions, and openings
 - 4. Platform deflection
 - 5. Edge guards
 - 6. Wheelchair retention
 - 7. Inner roll stop
 - 8. Handrails
 - 9. Platform markings on public use lifts
 - 10. Platform lighting on public use lifts
 - 11. Platform slip resistance
 - E. Structural Integrity
 - 1. Fatigue endurance
 - 2. Proof load
 - 3. Ultimate load
 - F. Platform free fall limits
 - G. Control systems
 - H. Jacking prevention
 - I. Backup operation
 - J. Interlocks
 - K. Operations counter
 - L. Owner's manual insert
 - M. Installation instruction insert
 - N. Test conditions and procedures
 - 1. Test devices
 - 2. Static load test I—working load
 - 3. Static load test II—proof load
 - 4. Static load test III—ultimate load
 - 5. Interlock test procedures
- IX. Vehicle requirements
- X. Benefits of the final rule
- XI. Costs of the final rule
- XII. Miscellaneous Issues
 - A. Axle weight limitations
 - B. Definitions in the FMVSS No. 403
 - C. Delayed compliance with the ADA
- XIII. Rulemaking Analyses and Notices Appendix to preamble

I. Background

We initiated this rulemaking proceeding concerning safety standards for platform lifts to provide practicable, performance-based requirements and compliance procedures for the regulations promulgated by the Department of Transportation (DOT) under the Americans with Disabilities Act of 1990¹ (ADA) and to ensure the safety of vehicles equipped with those lift systems. Under our statutory authority,² we establish Federal motor vehicle safety standards (FMVSS) to reduce motor vehicle crashes and the resulting deaths, injuries, and economic losses. Each standard must be practicable, meet the need for motor vehicle safety, and be stated in objective terms.³ The ADA does not relieve us of these requirements. Our authority extends to both motor vehicles and motor vehicle equipment. Further, we are authorized to regulate non-operational vehicle safety *i.e.*, safety while being maintained, serviced or repaired or while being entered or exited) as well as operational vehicle safety (*i.e.*, safety while being operated on public roads).

Today, we are adopting a final rule that establishes two new safety standards. The first, FMVSS No. 403, Platform lifts systems for motor vehicles, establishes minimum performance standards for platform lifts designed for installation on a motor vehicle. The second, FMVSS No. 404, Platform lift installations in motor vehicles, places specific requirements on vehicle manufacturers or alterers who install the lifts on new vehicles. Under this final rule, lift manufacturers will have to certify that their lifts meet the requirements of FMVSS No. 403, and manufacturers or alterers of new vehicles will have to ensure that the lifts are installed according to the lift manufacturer's instructions by certifying compliance with FMVSS No. 404. Affixing a label on the lift will effect the certification of compliance with FMVSS No. 403. Certification of compliance with FMVSS No. 404 will be on the certification label already required of vehicle manufacturers and alterers under 49 CFR part 567.

Title II of the ADA requires newly purchased, leased, or remanufactured vehicles purchased by public entities, like municipalities and regional transit authorities, and used in fixed route bus

¹ Pub. L. 101-336, 42 U.S.C. sections 12101, *et seq.*

² Formerly the National Traffic and Motor Vehicle Safety Act, currently codified as 49 U.S.C. sections 30101 *et seq.*

³ 49 U.S.C. 30111.

systems to be readily accessible to and usable by individuals with disabilities, including individuals who use wheelchairs, canes, and walkers. Title II also requires a public entity operating a demand-responsive transportation system to obtain accessible vehicles unless the system, when viewed in its entirety, provides individuals with disabilities with a level of service equivalent to that provided for individuals without disabilities. Title II further requires public entities operating a fixed route bus system (other than a bus system which provides only commuter service) to provide complementary paratransit and other special transportation services to individuals with disabilities. Title III requires that designated public transportation, provided by private entities, be readily accessible to and usable by individuals with disabilities, including individuals who use wheelchairs, canes, or walkers.

The ADA directed DOT to issue regulations to implement the transportation vehicle provisions in Titles II and III. Additionally, the ADA required the Architectural and Transportation Barriers Compliance Board (ATBCB) to issue guidelines to assist DOT in establishing these regulations.⁴ The regulations issued by DOT must be consistent with those guidelines.⁵ On September 6, 1991, ATBCB published its final guidelines which specify that to be considered accessible, a vehicle must be equipped with a lift or other level change mechanism and have sufficient clearance to permit a wheelchair to reach a wheelchair securement location once it is on the vehicle. (56 FR 45530) ATBCB stated that "NHTSA is the appropriate agency to define safety tests" for platform lifts.⁶ On the same day, DOT implemented the ADA by publishing a final rule establishing accessibility regulations at 49 CFR part 38, *Transportation for Individuals with Disabilities, Subpart B—Buses, Vans and Systems*, and by incorporating and requiring compliance with the September 6, 1991 guidelines issued by the ATBCB. (56 FR 45584) This document collectively refers to the

ATBCB's final accessibility guidelines and DOT's final rule as the "ADAAG".

Issuing motor vehicle safety standards provides the best way to ensure that only lift systems that comply with objective safety requirements are placed in service. The standards adopted today will ensure a level of safety and uniformity that should instill confidence in the user population.

Additionally, our regulatory framework provides specific procedures to address quickly vehicles and motor vehicle equipment that are out of compliance or contain a safety defect, including a procedure that can be followed to remedy the situation if a problem is found.

We believe the standards will be of benefit to lift manufacturers, vehicle manufacturers, alterers, and modifiers, as well as consumers. The platform lift standard was drafted to include or exceed all existing government (Federal Transit Administration (FTA), ADA, Department of Veteran's Affairs (DVA), California Title 13) and voluntary industry (e.g., Society of Automotive Engineers (SAE)) standards.⁷ A chart detailing which voluntary and Federal standards correspond to each of the requirements proposed in this document can be found at the end of the document in Appendix A. A lift manufacturer who certifies its lift to the standard should have confidence that the lift would also meet other major U.S. standards currently in force without additional testing.

We published a notice of proposed rulemaking (NPRM) on February 26, 1993 proposing to create a new safety standard for buses equipped with lift systems (58 FR 11562). On July 27, 2000, we published a supplemental notice of proposed rulemaking (SNPRM) (65 FR 46228), in part because the comments on the 1993 NPRM were over six years old. That notice provided for a 60-day comment period.

II. Summary of the SNPRM

The SNPRM differed from our original proposal in several respects. Most notably, the scope of our proposal was expanded to platform lifts installed on all motor vehicles rather than just buses. Second, we decided to propose two standards, instead of one, and to assign each of them a different Federal motor vehicle safety standard number:

⁷ The one area where the requirements for private use lifts do not meet or exceed voluntary industry standards is the specified minimum load. The SAE recommended practice provides for a standard load of 600 lb. As discussed later in this document, we are only requiring a specified minimum load of 400 lb for lifts certified to the personal use requirements.

Standard No. 141, instead of Standard No. 401, and Standard No. 142 (these designations have been changed to FMVSS No. 403 and FMVSS No. 404, respectively). We believed that two standards, one addressing the platform lift and another addressing the vehicle on which the lift is installed, would best protect lift occupants and bystanders. This two-prong approach is the same one we took in regulating override guards.

Other significant changes from the NPRM were the proposal of additional interlock requirements, improved wheelchair retention and platform slip resistance tests, and, in some instances, lesser compliance standards for lifts installed on vehicles typically used solely for private transport.

The proposed equipment standard, first introduced in the SNPRM, tentatively required platform lift manufacturers to ensure that their lifts meet minimum platform dimensions and maximum size limits on platform protrusions and gaps between the platform and either the vehicle floor or the ground. The proposed standard also contemplated requiring handrails, a threshold warning signal, and retaining barriers for lifts. Performance tests were specified for wheelchair retention on the platform, lift strength, and platform slip resistance. A set of interlocks was proposed to prevent accidental movement of a lift and the vehicle on which the lift is installed.

The proposed vehicle standard contemplated requiring vehicle manufacturers who install lifts to use lifts meeting the equipment standard, to install them in accordance with the lift manufacturer's instructions, and to ensure that specific information is made available to lift users.

Since the purpose of the two standards is to prevent injuries and fatalities during lift operation and to promote the uniformity of Federal standards and guidelines for platform lifts, we drafted the SNPRM both with the intent of protecting lift users aided by canes or walkers as well as lift users seated in wheelchairs, scooters, and other mobility devices.

We stated the costs associated with the proposed rule should be relatively low because we believed that most lift manufacturers are already complying with the existing voluntary and Federal standards. Accordingly, we believed lift manufacturers generally would not need to make substantial changes to their existing lifts, although some work may be needed to fully comply with the lift standard.

⁴ 42 U.S.C. 12204.

⁵ 42 U.S.C. 12186.

⁶ Throughout this document, we refer to lifts covered by the new standards as "platform lifts." The standards do not apply to ramps or devices where the disabled individual is transferred to a built-in mobility device. The lifts must meet the needs of wheelchair users and other individuals who are unable, due to a disability, to negotiate a vehicle's steps, e.g., individuals who use canes or walkers rather than a wheelchair. We have designed the standards with the needs of all mobility-impaired occupants in mind.

III. Summary of the Final Rule and Key Differences Between It and the SNPRM

A. Manufacturer Responsibilities Under the Final Rule

1. Platform Lift Manufacturers

As in the SNPRM, the responsibility for lift design and performance ultimately rests with the lift manufacturer. The lift manufacturer must not only provide a lift that complies with all of the performance requirements set forth in today's rule, but also installation instructions that provide sufficient direction to the lift installer so that the lift, when properly installed, fully complies with all the applicable requirements of FMVSS No. 403. Additionally, the lift manufacturer must determine, at the time of certification, whether the lift is appropriate for use by the general public rather than by a single individual.

2. Vehicle Manufacturers

Vehicle manufacturers also bear responsibility under today's rule. While they are not responsible for the design of a particular lift, they are responsible for installing a lift in a manner consistent with both FMVSS No. 404 and the lift manufacturer's installation instructions. Additionally, they are responsible for making sure that only public use lifts are installed on buses, school buses, and multi-purpose vehicles (MPVs), other than motor homes, with a GVWR greater than or equal to 4,536 kg (10,000 lb). Finally, they are responsible for assuring that the lift, as installed, meets all the operational requirements that are vehicle dependent. That is to say, the installed lift must operate as mandated by today's rule.

B. Platform Lift Requirements

Although we have adopted large portions of the regulation as set forth in the SNPRM, we have made numerous changes in today's final rule. First, we have decided not to adopt three of the ten interlocks proposed in the SNPRM. In addition, we have changed the weight-based distinction for determining whether an MPV must meet the more stringent requirements based on anticipated use by members of the general public and those requirements for lifts likely to only be used by a single individual. The determination of when a lift must meet the public use requirements has been increased to a vehicle GVWR of 4,536 kg (10,000 lb). We have also extended the rule's effective date from one year to two years. Finally, we have specified weight limits necessary to activate the

interlocks and alerts required by today's rule. We have also changed the standard load for private use lifts from 272 kg (600 lb) to the manufacturer's specified load or 181 kg (400 lb), whichever is greater.

IV. Summary of Public Comments

We received 25 comments in response to the SNPRM. Four industry associations submitted comments on behalf of their members. The National Mobility Equipment Dealers Association (NMEDA) represents businesses that modify vehicles for persons with disabilities. The American Bus Association (ABA) represents bus operators, manufacturers, and suppliers of products and services used by the bus industry. The United Motorcoach Association (UMA) represents motorcoach operators and suppliers. The American Public Transportation Association (APTA) represents transit systems, product and service providers, and state associations and departments of transportation. According to APTA, its members serve over 90 percent of all people who use public transportation in the United States and Canada.

The five lift manufacturers who commented, Stewart & Stevenson, Braun Corp, Ricon Corp., Lift-U, and Transport & Trolley, represent both the personal use market and the paratransit market. Seven companies representative of vehicle manufacturers also commented on the SNPRM. Blue Bird and Collins Industries (Collins) manufacture school buses. American Transport Corp. (ATC) and Motor Coach Industries (MCI) manufacture paratransit, or over-the-road buses. Prevost and VanHool are also bus manufacturers, but did not specify in their comments what types of buses they manufacture. Ride-Away Corp. alters and modifies personal vehicles for persons with disabilities.

Four state agencies, the Wisconsin Department of Transportation (Wisconsin DOT), the Oregon Department of Transportation (Oregon DOT), the Michigan Department of Transportation (Michigan DOT), and the New Jersey Transit Authority (NJ Transit), offered comment, as did two private citizens and one paratransit bus operator (DMN Enterprises). Finally, we received limited comments from R.C.A. Rubber, a rubber tread manufacturer, and Bendix Commercial Vehicle Systems, a manufacturer of air brake systems and components.

In general, the comments on most portions of the proposed standards set forth in the SNPRM were supportive. However, some commenters expressed significant, overarching concerns about

the possible impact of two new safety standards in this area. Specifically, several lift manufacturers raised concerns over the cost of meeting the new requirements and whether the agency had demonstrated a safety need sufficient to justify the proposed standards. Further, several over-the-road bus manufacturers and operators raised concerns about whether a new standard would delay full implementation of the ADA.

The state governments that commented were largely supportive of the proposal made in the SNPRM. For example, the Wisconsin DOT stated that all lifts owned or operated by state or local governments within the state already met or exceeded the proposed requirements.

V. Need for Safety Standards for Platform Lift Systems

As discussed in the SNPRM, we recognize that the vast majority of the American public does not need to use platform lifts. We believe, however, that individuals who do need to use them should have assurance that lifts are as safe as possible and should be protected from the risk associated with using unregulated equipment.

We acknowledge that there is a dearth of information regarding injuries associated with malfunctioning lifts. We believe that, from 1991 to 1995, at least 299,734 wheelchair users were injured. That figure, based on data collected by the Consumer Product Safety Commission during that time-frame as part of its National Electronic Injury Surveillance System (NEISS) database, is for all types of circumstances. 7,121 of these users were injured as a result of some interaction with a motor vehicle. In 1990, the Centers for Disease Control determined that 1.411 million people in the United States use wheelchairs. Thus, the NEISS figure of 299,734 represents an overall injury rate among the wheelchair-using population of slightly more than 21 percent. While only 7,121 of these people were injured during the five-year period as a result of interaction with a motor vehicle, 26% (1,366) were the direct result of some unspecified type of lift malfunction. When broken down on an annual basis, the NEISS data projects 248 injuries per year.

We anticipate that more people will use lifts on motor vehicles as the ADA requirements make transportation more accessible to individuals with mobility impairments and as the proportion of older people in the general population increases. As the number of lift-equipped vehicles increases, the number of lift-related injuries is also

likely to go up. Indeed, our analysis has already revealed an upward trend in the number of lift-related injuries.

We believe there may be considerably more injuries due to malfunctioning lifts than the numbers suggest. Any analysis of deaths or injuries based on motor vehicle-incidents will necessarily under-represent the scope of the problem. Since lift-related injuries frequently are not reported as a motor vehicle incident, no police report is filed. Consequently, the event is not entered in the data bases that we search for injury and death information related to motor vehicles (e.g., police reported incidents from states, NASS, and FARS). Additionally, the injury count understates the number of actual injuries because it does not include incidents in which the injured persons were treated at small hospitals, emergency care centers, or doctor's offices.

Recognizing the dearth of available data, we asked commenters to respond to several questions that we posed in the SNPRM. Specifically, we sought comment on the size of the potential lift using population; the number of lifts installed on motor vehicles since 1997, with a breakdown of that number between lifts that were installed by lift manufacturers and lifts that were installed by someone else; the number of MPVs with ramps instead of lifts; and how many lifts were installed on vehicles prior to their first sale for purposes other than resale, with breakdown by entity that installed them. We also sought comment on which of the proposed requirements would most contribute to a reduction of injury and why.

Collins noted that approximately 30% of the buses it builds are equipped with platform lifts. It further noted that while in 1997 approximately 15% of the buses it manufactured were equipped with a lift-accessible service door but were not equipped with a lift, that number has shrunk to about 3%. Collins posited that the new regulation would eliminate that portion of the market. ATC stated that since 1997 it has installed approximately 858 lifts in their own vehicles and had produced approximately 171 buses with lift accessible doors but without a lift.

Ricon estimated that someone other than the vehicle manufacturer installs approximately 40% of lifts. It noted that the percentage of lifts installed by lift manufacturers is negligible. NJ Transit stated that since 1997 all of its transit buses, cruisers, minibuses and vans have had lifts installed by the vehicle manufacturer.

NMEDA noted that local dealers, who may be alterers or modifiers, install the vast majority of personal use lifts. It stated that local dealers are also responsible for installing a smaller majority of commercial lifts.

The ABA and UMA stated that NHTSA had not demonstrated a sufficient safety need for the adoption of new FMVSSs. UMA stated that it had contacted its user and insurance members and had not identified a single instance of a disabled traveler being injured or killed because of a lift design problem. It maintained that the injuries of which it is aware have all been a result of poor maintenance or training practices. ABA stated that it believed the dearth of injury data after the passage of the ADAAG indicates that lifts perform well under the current set of lift requirements and that no further regulation is needed.

The ABA and UMA and MCI also maintained that the proposed standards, if adopted, would delay the implementation of ADA requirements on over-the-road buses as bus operators will delay purchasing lift-equipped buses until bus and lift manufacturers have retooled their designs so as to comply with the new standards. Stewart & Stevenson noted that the lift industry has already expended significant development costs in meeting the ADAAG and California Title 13 requirements. It stated that the proposed requirements would impose additional costs on the lift manufacturer, vehicle manufacturer, and consumer.

Mirroring the argument by UMA that operator error was a larger problem than lift malfunction, DMN Enterprises and MCI argued that the proposed standards do not adequately consider the presence of a trained lift operator on transit vehicles. DMN Enterprises also believed that the costs might be minimal for several of the proposed requirements, but that the additional costs in several areas such as platform deflection, interlocks, and angular orientation during free fall would require major redesign and potentially high costs. It also asked why NHTSA did not consider adopting the California Title 13 test requirements rather than devising new requirements. Finally, it urged NHTSA to commit to developing standards addressing ramps and securement devices since the transit industry is moving towards greater use of ramps and less on platform lifts.

We acknowledge the dearth of data typically relied on by NHTSA in determining whether a particular safety standard meets the need for motor vehicle safety. However, as discussed above, we do not believe that the lack

of concrete data necessarily means that there is no need to regulate the safety of platform lifts. Our determination that today's standards meet the requisite need for safety is based primarily on engineering assessments made by the SAE, FTA, and DVA, and verified by NHTSA, that certain safety features are needed for platform lifts. Today's rule merely establishes measurable performance standards that incorporate the existing recommended practices and guidelines.

VI. Differing Safety Needs for Private and Public Use Platform Lifts

In the SNPRM, we discussed whether it would be appropriate to have fewer requirements for platform lifts installed on MPVs than for those installed on buses. The reason for that difference is that lifts designed for MPVs have different usage patterns than those designed for buses. We proposed that buses and MPVs greater than 3,200 kg (7,100 lbs) meet stricter requirements than other vehicles. At that time, we believed that this was an appropriate cut-off, given that most of these larger vehicles are for public transit and paratransit use, instead of individual use. Since the lifts on these vehicles will generally be subjected to more stress and cyclic load and will be used by a larger and more varied population, more requirements as to platform size, controls, handrails and lighting appeared appropriate. We noted that where the ADA imposes requirements on commercial entities and those entities use a vehicle that weighs less than 3,200 kg, the commercial entity would still have to meet the applicable ADA requirement. We then requested comment on whether it is appropriate to have less stringent requirements for lifts designed for installation on motor homes, trucks, truck tractors, trailers, and MPVs less than 3,200 kg. We also sought comment on whether 3,200 kg was the correct breakpoint, and if not, what was.

Several commenters, including individuals, lift manufacturers, modifiers and vehicle manufacturers stated that the breakdown of lift requirements based on GVWR was unworkable since many individuals purchase vehicles that have a GVWR greater than 3,200 kg to accommodate the needed vehicle modifications or to provide additional cargo capacity. The majority of commenters argued that the division should be based on whether the lift would be used in a commercial setting or solely for personal use. NMEDA suggested the lift manufacturers be required to mark their lifts as suitable for personal or

commercial use. Collins and Ride-away suggested the GVWR break-point be raised above 3,200 kg, with Collins suggesting a division at 4,536 kg (10,000 lb) GVWR.

Additionally, a private citizen and MCI argued that the requirements for private-use lifts should be no less stringent than those used for transporting the general public. MCI noted that operators of public-use lifts are trained in the proper operation of the equipment and, as demonstrated by NHTSA's own data analysis, that fewer injuries occur on lifts installed in buses than on lifts installed in MPVs. Braun supported adopting less stringent requirements for personal-use lifts.

As discussed in the SNPRM, defining a safety standard solely in terms of whether the vehicle or motor vehicle equipment is intended for private or public use fails to meet the statutory meaning of objectivity unless the agency clearly defines private and public use in a manner that is readily applicable to lift manufacturers and vehicle manufacturers. We are, however, persuaded that a break-point of 3,200 kg for MPVs will likely place unreasonable restrictions on many individuals who use their vehicle for purely personal transportation. Accordingly, we have raised the upper limit for MPVs that may use lifts that are not certified to all of the standard's requirements to 4,536 kg GVWR. Not only is this one of the break-points NHTSA has traditionally used to differentiate between private and commercial vehicles, but we also believe this break-point will accommodate almost all MPVs purchased for personal use.

As proposed in the SNPRM, the lesser requirements will also be applicable to those lifts designed for use on motor homes, trailers and tractor-trucks, since these vehicles are generally not used to transport the general public. The lifts that meet the lesser requirements shall be certified as DOT-private use compliant. Private use is defined in the standard as those lifts designed for installation on motor homes, trailers, truck tractors and MPVs with a GVWR less than 4,536 kg, and that are certified as compliant with the lesser requirements. The certification label on these lifts shall bear the statement "DOT-private use lift".

We note that the requirements of the ADA still apply to all lifts installed on vehicles used as public conveyances, either by public entities or by private entities that transport members of the general public, regardless of vehicle size. Thus, in many instances a lift manufacturer may choose to manufacture a lift that meets the stricter

requirements, either because it does not wish to develop a separate lift design, or because the lift will be installed on a smaller MPV that is used for the transportation of the general public. Under today's rule, lifts designed for use on vehicles smaller than 4,536 kg be certified to the stricter requirements. Lifts designed for installation on all buses and on MPVs with a GVWR in excess of 4,536 kg must be certified to the stricter requirements and will be defined in the standard as public-use lifts. Likewise, those lifts that are certified as meeting the stricter requirements are defined as public-use lifts, even if they may be installed on vehicles that are not buses or MPVs with a GVWR less than 4,536 kg. The certification label on these lifts shall bear the statement "DOT-public use lift".

Throughout the rest of this document, the differences in requirements, both in the final rule and as discussed in the SNPRM, will be discussed in terms of private use lifts and public use lifts.

VII. Effective Dates

We received ten comments on the proposed one-year effective date. Three of the commenters (Braun, MCI and Collins) believed a one-year effective date was sufficient, although Braun indicated that many of the proposed requirements—particularly the proposed interlocks—would require costly and complex product redesign which would require additional leadtime. Other commenters maintained that too many changes were required to be achieved in one year. These commenters suggested an effective date ranging from two to five years. The commenters were particularly concerned about the time needed to comply with the proposed interlock requirements.

NMEDA commented that the requirements should only apply to lifts manufactured after the effective date and installed on new vehicles. In a similar vein, APTA was concerned that the proposed regulations did not address lifts installed on vehicles that had been purchased before the effective date.

NJ Transit believed the effective date should exempt existing bus orders placed by mass transit authorities as such orders can carry over multiple years. It argued that changing lift equipment in the middle of a bus order could be confusing to customer, and could increase manufacturing and maintenance costs.

Based on the comments, we have decided to adopt a two-year effective date. We believe this time frame will

provide lift manufacturers sufficient time to meet any new requirements. As discussed in the SNPRM, most of the requirements adopted in today's rule are already part of an existing standard or guideline. Accordingly, lift manufacturers should not need a significant amount of time to ensure their lifts comply with the new FMVSS. As to NMEDA's and APTA's concern that the new standards not apply to lifts or vehicles manufactured before the effective date, we note that both FMVSS No. 403 and FMVSS No. 404 have a two-year effective date. Thus, only lifts manufactured after the effective date need to be certified as compliant with FMVSS No. 403 and only vehicles manufactured after the effective date need to be certified as compliant with FMVSS No. 404. FMVSS No. 404 will not apply to vehicles manufactured before the effective date even though those vehicles may have FMVSS No. 403 compliant lifts. However the use of a compliant lift, even on the older vehicles, should provide an added measure of safety.

We are unable to provide a separate effective date for vehicles that are covered by multi-year purchase orders, as NJ Transit urges. Such a provision would be non-objective and impossible for us to enforce. However, we believe the two-year delay in the effective date will provide transit operators, such as NJ Transit, to make whatever contract modifications are necessary on existing purchase orders and to ensure that all future purchase orders specify the installation of compliant lifts.

VIII. Platform Lift Requirements

Threshold Warning Signal

In the SNPRM we proposed to require a threshold warning alarm to alert vehicle occupants near an operating lift. For private use lifts, the alarm could be either audible or visual. Under the proposal, public use lifts would need to have both a visual and an audible alarm since these larger vehicles are generally used for commercial transport. In all vehicles, the alarm would have needed to warn lift users if the lift platform were more than one inch below the vehicle's floor reference plane and if any portion of the platform threshold area⁸ were occupied by any portion of the lift occupant's body or any piece of equipment. This warning requirement

⁸ The platform threshold area is defined in the regulatory text as the rectangular portion of the vehicle floor defined by moving a line, which lies on the edge of the vehicle floor directly adjacent to the lift platform, through a distance of 18 inches (457 mm) in a direction perpendicular to the line including any portion of a bridging device that lies within this area.

was based on an SAE recommended practice specifying a warning if the lift user is within 18 inches of the platform and the platform is more than one inch below the vehicle's floor reference plane.

We stated in the SNPRM that we considered a warning alarm to be particularly important in transit and paratransit vehicles where more than one individual may use the lift sequentially. It would also be important in any personally licensed vehicle in which the lift is fitted such that the user backs onto the lift from the floor of the vehicle (this typically occurs on lifts fitted to the rear of the vehicle), since we did not believe such systems posed the same type of risk to the lift occupant or bystanders. The proposed requirement would not have applied to rotary lifts where loading takes place entirely over the surface of the vehicle's floor. We sought comment on whether an audible or visual threshold warning should be required and whether the warning would avoid injuries to users caused by an out-of-position platform. We also sought comment on whether a minimum size or weight should be specified to trigger the warning (and, if so, what that size or weight should be).

Additional concerns were raised about the effect a visual or audible alarm could have on individuals with certain medical conditions such as epilepsy. Accordingly, Ricon and Braun suggested that NHTSA allow a mechanical threshold barrier as an alternative to an audible or visual alarm. In response to our question as to whether a minimum weight should be specified to trigger the threshold alarm system, Braun and NMEDA argued that the warnings only be required to activate when the sensors detected a weight greater than 50 lb.

The Oregon DOT supported requiring an audible threshold-warning signal. It maintained such a signal would not only protect lift occupants during sequential loading, but would also warn a driver or attendant when a passenger with impaired cognitive ability approached the lift door when the lift was fully deployed.

Other commenters opposed the adoption of a threshold warning alarm, particularly for lifts used in a commercial environment. Prevost posited that a threshold-warning requirement should only be required in those instances where the lift occupant must operate the lift without assistance. Along with MCI, it maintained that the requirement should not apply to lifts installed on over-the-road buses since the drivers of these buses have been trained to load and offload disabled

individuals from the bus, obviating the need for an alarm.

Stewart & Stevenson stated that most vehicle manufacturers already have a visual or audible warning that is activated when the lift is activated. It stated that these warning systems are effective, even though they are not activated whenever an individual is within 18 inches of the lift. It further averred that imposing such a requirement would increase the cost of lift design and compliance with no associated benefit. RICON, Braun, NMEDA and Prevost all stated that the proposed threshold area should be reduced to twelve inches, at least for non-commercial, non-transit vehicles. Braun noted that an eighteen-inch threshold area could consume as much as 30 percent of the interior width of a standard-size van.

MCI stated that while SAE J2090, *Design Considerations for Wheelchair Lifts for Entry to or Exit from a Personally Licensed Vehicle*, specified a threshold warning system, it is unaware of any manufacturer of personal use lifts who actually incorporates this feature into its lift design. It additionally claimed that it has never heard of an accident that would have been avoided if the lift had been equipped with a threshold-warning signal. Finally, MCI noted that often the wheelchair securement location is within the 18-inch area proposed in the NPRM and that requiring the alarm to go off whenever that area is occupied and the lift is in motion could draw undue attention to wheelchair occupants.

Section 4.4.6 of the State of California Department of Rehabilitation's Specifications for Adaptive Driving Equipment has required threshold warning systems for lifts installed on private vehicles since 1985. It adopted this requirement after six clients of the state's Mobility Evaluation Program were killed after backing their wheelchair off a vehicle when they thought the platform was in place. Since instituting this requirement, no other falls have come to the attention of the Mobility Equipment Program. Currently Braun provides a platform warning alarm system as optional equipment to at least some of its lifts. We believe that the vehicle modifiers are placing the warning devices in vehicles equipped with lifts manufactured by other companies are meeting the California requirements by installing simple weight detection devices on the floor of the vehicle.

Given the risk involved in backing off a vehicle when the lift is not properly positioned, we have decided to adopt the requirement for a threshold warning

system as proposed in the SNPRM. Under today's rule, the threshold warning system must activate whenever the platform is more than 25 mm (1 in) below the vehicle floor reference plane. Several types of detection systems may be used to satisfy this requirement. In order to test for compliance with the requirement we have decided to place one front wheel of the wheelchair test device specified in the standard within the threshold area. This will place approximately 11.3 kg (25 lb) on the threshold. This amount of weight roughly replicates the weight of the lightest portion of an average wheelchair or half the weight of a child who may be using the lift unattended. We have decided against specifying a particular minimum weight because wheelchairs will place slightly differing amounts of weight depending on design. We believe the threshold should reasonably detect the weight of any occupant in a mobility device and any bystander who is likely to be unattended. We note that the rough approximation of weight represented by placing one wheel of a mobility device in the threshold area should allow individuals to place light objects, such as books or handbags, within the area without triggering the alert.

We are unconvinced that there is no need to require a threshold warning alert for over-the-road buses. Prevost and MCI may be correct that in general the lift operators on over-the-road buses have received specialized training in how to use the lift. However, we have no control over the level of training provided. Additionally, the lift operator may actually operate the lift from a position remote from the lift platform, such as the driver's seat. In such an instance, the operator would not be able to ensure that no other vehicle occupants were a safe distance from the lift throughout the range of lift operations.

We believe the 18-inch threshold area requirement is important for safety, particularly for wheelchair users who back onto the lift platform from the vehicle floor. If the threshold is reduced to twelve inches, as suggested by commenters, the wheelchair may be so close to the edge of the vehicle floor that the occupant will be unable to react in time to prevent the wheelchair from continuing the wheelchair's movement off the edge of the vehicle floor. The standard only requires the alert be activated when the lift is deployed, the threshold is occupied, and the lift platform is more than one inch below the level of the vehicle floor. In private vehicles the alert would only be activated when the lift is deployed and

a vehicle occupant is either in the threshold area or simultaneously on the threshold and the platform after the lift had started moving. The same is true for transit and paratransit buses, except the alert could also activate while the lift was being used properly and another occupant was in the threshold area. While the commenters may be correct that the alert will notify all vehicle occupants that the lift is being operated, we do not believe the alert is any more likely to draw attention to a lift user than the operation of the lift itself.

Today's requirement specifies that the audible alert be at least 85 dBA and the visual alert have a frequency of 1 to 2 Hz. We believe these specifications are unlikely to lead to seizures in or cause other medical or physical impairments to vehicle or lift occupants. The 85-dBA level of the audible alarm is a frequently used level for enunciators. An individual can be exposed to this sound level for the length of time the alarm will operate without sustaining hearing loss or other negative repercussions. The low frequency flash of the visual alert (1 to 2 Hz) is in line with the frequency of warning flashers commonly used in automotive and highway applications. The flash frequency is also in line with our existing requirements in FMVSS No. 108, Lamps, reflective devices, and associated equipment, which incorporates by reference SAE recommended practice J590B, Turn Signal Flashers, for the visual flash rate of hazard warnings. SAE J590B stipulates a rate of 60 to 120 flashes per minute, which translates to a frequency of 1 to 2 Hz. We are unaware of any seizures related to the use of hazard devices required under FMVSS No. 108.

We believe lift systems that use a mechanical barrier to prevent a vehicle occupant from falling off the edge of the vehicle are used only rarely, if at all. Certainly such devices are not addressed by existing recommended practices or guidelines. In any case, we have decided against allowing such a barrier as an alternative to the threshold warning alert, as we have some concerns about the safety of such a device. Such a barrier could retain powered wheelchairs, but they would also create a tripping hazard for persons using canes and walkers. Additionally, mechanical barriers could impinge on an occupant's ability to exit the vehicle during an emergency situation. If warning systems other than those related to a threshold warning alert are developed, NHTSA could change the standard to allow such systems.

B. Platform Lift Operational Requirements

1. Maximum Platform Velocity

We proposed maximum platform operating speeds for the safety of lift users, especially standees (*e.g.*, individuals who use a cane or walker). The SNPRM specified a maximum vertical and horizontal velocity of the platform of 152 mm/s (6 in/s) in order to assure the safety of those on or near the lift and to be consistent with the ADAAG (49 CFR 38.23(b)(10)) and FTA guidelines (section 2.5.11), which also allow a maximum velocity of 152mm/s (6 in/s).

Based on our review of the ADA standard, we also decided to propose that during stowing and deploying, the lift platform would have a maximum vertical and horizontal velocity of 305 mm/s (12 in/s). The purpose of this requirement was to reduce the potential injuries to bystanders and lift users. We requested comment on safety need for velocity limits while platform is stowing and deploying and whether any commenters knew of any instances where someone was injured because the lift was stowing or deploying too quickly.

We received comments both supporting and opposing the adoption of a maximum operating velocity during the stowage and deployment portion of lift operation. Collins noted that while it no longer manufacturers platform lifts, it knew of very few accidents that resulted from excessive folding speed when it was manufacturing lifts. Braun also knew of no incidents related to excessive stowage or deployment speed. It stated, however, that 305 mm/sec (12 in/sec) appeared a reasonable speed to prevent injuries. Braun also requested the agency specify where on the lift to measure a maximum radial velocity during the stowage and deployment operations, suggesting a point 610 mm (24 in) from the platform pivot.

We have decided to adopt a requirement limiting the maximum velocity of platform lifts throughout the lift's range of operation. We are not persuaded that specifying a maximum platform velocity, both throughout the range of passenger operations and the stowage and deployment operations, imposes an unreasonable burden on the lift manufacturer. Today's requirement is based on existing requirements, which may explain why commenters are unaware of any accidents related to excessive platform velocity. However, the fundamental risk of injury from a lift that is moving too quickly remains unless there is a requirement that limits the lift's operating velocity.

We agree that it is appropriate to specify where on the lift the agency will measure maximum velocity during the range of operation. The regulatory text has been changed accordingly. Additionally, we recognize that some lifts use a hinged platform lift that pivots down when deployed and up when stowed. On these lifts the highest platform velocity occurs at the outer edge of the platform. In order to clarify that the maximum velocity of these lifts are covered by the standard, we have changed the regulatory text to specify that during the stowage and deployment portions of lift operation no portion of the lift shall exceed 305 mm (12 in/sec). Otherwise the requirements for maximum operating velocity have been adopted as proposed in the SNPRM.

2. Maximum Platform Acceleration

We decided to propose in the SNPRM an acceleration limit of 0.3 g with the platform both loaded and unloaded. The acceleration would be measured along axes horizontal and perpendicular to the lift platform. The no load condition was intended to ensure that even very light occupants would be protected against a sudden increase in lift speed, since very small children may use lifts, especially in school buses. By requiring compliance at any load in between the extremes, we intended to ensure that acceleration remains within the desired limits. While the proposed test procedure was based on the one specified in SAE recommended practice J211, Instrumentation for Impact Test, we proposed to depart from that test procedure by measuring acceleration with a CFC 3 filter rather than a CFC 60 filter. We believed the CFC 3 filter better represents a wheelchair's dampening characteristic. Since no one objected to this portion of the proposal, we have adopted it as proposed.

3. Maximum Noise Level of Public Use Lifts

We proposed a maximum permissible noise level of 80 dBA in the SNPRM. This level represents the maximum permissible volume of ambient noise allowing for normal communication between two people who are three feet away from each other and exceeds the level of ambient noise at a city bus stop.⁹ We sought comment on whether commenters knew of any injuries directly attributable to lift occupant and lift operator being unable to communicate.

⁹ See An Evaluation of the Proposed Wheelchair Lift Safety Test Procedure, (June, 1996) located at docket No. NHTSA-98-4511-4.

Braun, NMEDA, and Ricon all requested the agency provide a specific distance for measuring lift noise levels. They indicated that measurement point of "lift operator's position" was too vague since the use of a pendant control could allow the lift operator to be several feet away from the lift. Ricon suggested we adopt a measuring point located 55 inches above the platform while the lift is in use. Collins indicated that it knew of no instances in which a lift occupant or bystander was injured because the driver could not hear the passengers. It was, however, aware of instances in which the driver had ignored a passenger during lift operations. The Oregon DOT asked whether NHTSA had taken account of the accumulative effect of additional noise on people with impaired hearing when determining the maximum amount of allowable lift noise. VanHool asked whether the noise level was measured while the vehicle engine was running and whether the maximum noise level was inconsistent with the requirement that the audible alarm produce at least 85 dBA.

We are adopting the requirement as proposed in the SNPRM with slight modification. The purpose of today's requirement is to ensure the lift user and lift operator will be able to communicate. Since lift operators for private use lifts are likely to be the lift user, we believe there is no need to specify a maximum level of noise that the lift may produce. Accordingly, today's requirement only applies to those lifts certified as public-use lifts.

The commenters are correct that the proposed measuring point of the "lift operator's position" was insufficiently objective in the SNPRM to measure maximum noise levels. They are also correct that this uncertainty is exacerbated in systems that use a pendant control, since the location of that control varies based on where the lift operator is standing. Accordingly, we have changed the requirement to state that the maximum noise level will be measured for each operator position specified by the lift manufacturer in the installation instructions. Measurements are taken at the vertical centerline of the face of the control panel 30.5 cm (12 in) out from the face of the control panel. If the lift system uses a pendant control, the vertical measurement point will be at the same location discussed above, but with the control panel in its stowed or stored position, since this places the control at the point closest to the noise source. For controls located outside of the vehicle, the horizontal measurement is 157 cm (62 in) above the ground, which is roughly the same distance from

the ground as an adult's ears, while the vertical measurement remains 30.5 cm (12 in) from the face of the control panel.¹⁰

We did not make any adjustments based on the accumulated effect of noise on individuals with impaired hearing since the lift would only be in use for a short period of time. Additionally, we note that the required 85-dBA audible threshold warning alert exceeds the maximum allowable amount of noise for lift operations. This is intentional. As noted earlier, the audible alert will only sound during lift operations if the threshold area is occupied. Thus, it generally would not be constant throughout the range of lift operations. Additionally, the audible alert should be sufficiently greater than the maximum level allowed for normal lift operations to make it distinguishable.

C. Environmental Resistance

In the SNPRM, we tentatively proposed adopting the SAE requirements for externally mounted lifts. Additionally, we proposed all attachment hardware, regardless of location inside or outside the vehicle, meet the hardware requirements of FMVSS No. 209, Seat belt assemblies, which permits compliance either by passing a salt spray test or by electroplating the components. We sought comment on whether the proposed environmental resistance requirements should be incorporated into the standard.

While the majority of those commenting on this issue supported adding an environmental resistance requirement to the standard, Lift-U maintained that the requirement for electroplating with nickel or a nickel copper alloy was too restrictive. Lift-U also suggested that all lifts, regardless of storage location, meet the SAE requirements for environmental resistance.

Given the strong support among most commenters for an environmental resistance requirement, we are adopting the requirement as proposed in the SNPRM. Both the requirement and test procedure for external components are based on the SAE recommended practice. All attachment hardware, regardless of location, must meet the requirement for attachment hardware specified in FMVSS No. 209. That standard provides for two alternative means of compliance: either by passing the salt spray test or by electroplating with a nickel or nickel/copper coating. We are not extending the SAE-based

requirement to hardware located within the occupant compartment of the vehicle because that hardware will not be subjected to environmental conditions any more severe than the hardware regulated by FMVSS No. 209.

D. Platform Requirements

1. Unobstructed Platform Operating Volume

In the SNPRM, we proposed a minimum clear platform width of 724 mm (28.5 in) on the upper surface of the platform, a minimum clear width of 762 mm (30 in) at and between the heights of 51 mm to 762 mm (2 to 30 in) above the platform surface, and a minimum clear length of 122 cm (48 in) above the surface of the platform. No part of the lift or vehicle (except for a required barrier on a platform edge) could intrude into the area above the portion of the platform that would be occupied by a large wheelchair at any point during its operation. No minimum volume was specified for private use lifts, although the vehicle owner's manual insert would have had to specify the unobstructed platform operating volume. We sought comment on whether the suggested approach for private use lifts was appropriate.

The majority of the commenters agreed that it was appropriate to allow lift manufacturers to provide an unobstructed operating volume for private use lifts that was different than that proposed for public use lifts as long as the lift manufacturer disclosed what the unobstructed operating volume was. Collins stated that it could not see any justification for allowing a different size for private use lifts since the lift occupants are the same as those occupants using a commercial lift. APTA and the Michigan DOT averred the width of the upper segment of the unobstructed operating volume for commercial lifts should be increased to 813 mm (32 in) to accommodate scooters.

While Collins is correct that there is no difference in the size of occupants who use personal lifts and occupants who use public lifts, we believe there is a significant difference in lift usage. Personal lifts are generally only used by a single occupant. We expect that occupant will purchase a lift that is suitable for his or her needs. An individual with a large wheelchair or scooter will purchase a lift that accommodates a larger mobility device. An individual with a smaller mobility aid will have no need of a larger lift and may be able to increase his or her vehicle choice by purchasing a lift with a smaller size capacity. In either

¹⁰ See US/DOT/FAA Human Factors Design Guide, January 1996, NHTSA-02-13917.

instance, the individual using the lift has an input as to which lift to purchase. This is why we believe there is no need to specify a minimum operating volume for personal use lifts as long as the lift manufacturer notifies the lift user of the maximum operating volume.

However, public use lifts are designed to accommodate the needs of several individuals. The transit operator has no way of knowing whether a smaller lift would accommodate the users of the lift. Indeed, it must assume that there will be instances where a larger lift is required to accommodate a particular lift occupant. In these vehicles the question of user choice has been removed. If the transit operators do not purchase sufficiently large lifts, some potential users will be deprived of the opportunity to use the lift.

We recognize the concerns of APTA and the Michigan DOT that the minimum operating volume may be too small to accommodate all mobility devices currently on the market. We too have some concerns that lifts designed to only meet the minimum operating volume may preclude some users from using a public use lift. However, today's requirement is based on existing requirements and the existing design of most lifts. If we were to specify a larger minimum operating volume, we believe a significant number of lifts would have to be redesigned before they could be certified as compliant. We note that nothing in today's rule prevents lift purchasers from procuring lifts with a platform operating volume that is greater than what is required in the standard. We would also expect scooter manufacturers to design their devices in a manner that allows the user to have access to public transportation.

2. Platform Surface Protrusions

For public use lifts, the SNPRM proposed the upper surface of the platform be free from protrusions greater than 6.5 mm (0.25 in) high, and proposed a test procedure for measuring the height of such protrusions. Private use lifts would be allowed to have protrusions up to 13 mm (0.5 in). The proposed limit for private use lifts was less than that required under ADAAG regulations; however, we believed the ADAAG regulations were overly stringent for the private use lifts (which are not subject to ADAAG regulations in any case). For these lifts, we continue to believe that slightly higher protrusions can be allowed for smooth rise without either compromising safety or decreasing the vehicle's accessibility as long as the transition between the platform and the protrusion is gradual.

We received no comments regarding surface protrusions. We continue to believe that allowing protrusions to be between 6.5 mm and 13 mm (0.25–0.5 in) for personal use lifts is consistent with safety for vehicles that will be used by one person with one type of mobility aid. This is also consistent with the transition requirements described in the next section. Accordingly, we are adopting the surface protrusion requirements as proposed in the SNPRM of no more than 6.5 mm on public use lifts and no more than 13 mm on private use lifts.

3. Gaps, Transitions, and Openings

As discussed in the SNPRM, we proposed the openings in the upper surface of the platform be no greater than 19 mm (0.75 in). No vertical surface transition could be more than 6.5 mm (0.25 in) at either the ground or vehicle level and horizontal gaps would be limited to 13 mm (0.5 in). The total allowable rise of any sloped surface (typically ramps or bridging devices) would be limited to 76 mm (3 in). The proposed allowable slope on the portion of the rise between 6.5 mm and 13 mm (0.25 and 0.5 in) above the ground, platform surface, or vehicle surface would be limited to a 1:2 ratio and a 1:8 ratio would be allowed for the portion of the ramp above 13 mm (0.5 in). Gaps between the upper surface of the platform and either the outer barriers or the inner roll stops would be limited to no more than 16 mm (0.625 in) when fully deployed. Gaps would be tested with a 16 x 16 x 102 mm (0.625 x 0.625 x 4.0 in) test block that could not pass through any gaps. Gaps between the lift and edge guards permanently affixed to the ramp could not exceed 13 mm (0.5 in) throughout the range of lift operation. Edge guards that are an integral part of the vehicle could not be more than 6.5 mm (0.25 in) from the platform throughout lift operation.

Lift-U suggested that we limit the restrictions on maximum gap size to the usable platform surface, instead of the entire platform surface, as there may be gaps that are greater than the proposed 19 mm (0.75 in) behind linkages. Since the mobility device or lift passenger does not have access to these portions of the lift, Lift-U argued that there was no need for a maximum size limitation. No other comments were submitted regarding the proposed requirement.

We believe Lift-U's point is well taken. We are only concerned with the area of the platform that coincides with the portion of the platform that may be occupied. Accordingly, we have changed the wording regarding gaps, transitions and openings to indicate that

the applicable platform area for this requirement is the area of the platform that coincides with the unobstructed platform operating volume.

4. Platform Deflection

We proposed requiring that the platform angle not deviate from the vehicle floor by more than one degree when the platform is unloaded and by more than three degrees when the platform is loaded. We also proposed platform deflection be tested with a platform load of 272 kg (600 lbs), centrally placed on the lift. The amount of deviation would be measured throughout the lift cycle. This technique is consistent with the one used in the Department of Veterans Administration procurement standard that a specified deflection limit may not be exceeded either before or after loading. The proposed three-degree limit is consistent with both the FTA-sponsored guidelines (sections 2.2.5 and 3.1.3) and the ADAAG (49 CFR 38.23(b)(9)). Testing throughout the lift cycle is also consistent with the FTA requirement that lifts must meet the deflection limit during the entire lift cycle. We requested comment on whether platform deflection should be included in vehicle standard as well as lift standard, limiting the effect of vehicle suspension on lift deflection.

The majority of commenters on this issue indicated that platform deflection relative to the ground is very difficult to measure since the amount of deflection is vehicle-dependent. Collins indicated that heavier lifts will deflect less than those designed for personal use. ATC stated that it had actually measured the level of deflection at ground level on two different buses with the lift loaded with 600 lb of ballast and found the difference in deflection to be minimal. Lift-U noted that some of their lifts are designed to deflect more than one degree to accommodate less-than-ideal road conditions. By design, these lift platforms angle two degrees toward the vehicle centerline when the lift is at the vehicle floor and two degrees away from the vehicle centerline when at ground level.

Lift-U noted that with over 100,000 of these lifts in use, they have an excellent safety record. Accordingly, Lift-U suggested NHTSA adopt a maximum unloaded deflection angle of 1.8 degrees with respect to the vehicle floor with a maximum loaded angle of an additional three degrees with respect to the unloaded position. In both instances, it urged that we not allow a total slope that exceeds a 1:12 ratio. Lift-U maintained that this approach would allow design flexibility and would be

consistent with the ADA requirement for general access to buildings. Prevost noted that the suspension on its vehicles provide a roll angle of one to two degrees when the lift is deployed and loaded.

Because vehicle suspension appears to play only a nominal role in the amount of overall deflection, we have decided to measure platform deflection only as it relates to the vehicle floor. This is what we had proposed in the SNPRM. However, we have made changes to the proposal based on Lift-U's comments. We believe the FTA standard described by Lift-U will adequately protect against excessive deflection. Under the FTA specification, a lift could deflect no more than 4.8 degrees, even when fully loaded. Allowing a maximum deflection of 4.8 degrees, with no more than 1.8 degrees deflection of an unloaded lift (as measured from the vehicle floor reference plane) is consistent with the FTA specification and slightly more stringent than the SAE recommended practice, which specifies a total maximum loaded deflection of 3.6 degrees as compared to its preloaded position. Adopting this slightly more lenient level will obviate the need to make costly changes to existing lift systems.

5. Edge Guards

In the SNPRM we proposed requiring edge guards that were at least 38 mm (1.5 in) high and sought comment on whether any existing passive lifts have edge guards that extend beyond the lowest step riser when the lift is functioning as vehicle steps and whether such a design creates a tripping hazard. We proposed the 38 mm (1.5 in) height because we believed it would be sufficient to deflect the motion of the wheelchair and alert the wheelchair occupant that the wheelchair is at the edge of the platform. Edge guards of this height are required by both the FTA-sponsored guidelines (section 2.2.6.1) and the ADAAG (49 CFR 38.23(b)(5)).

We requested comments on whether any existing lifts have edge guards that extend beyond the lowest step riser when the lift, in a stowed position, converts into vehicle steps, and whether such edge guards create a tripping hazard when the lift is stowed.

Collins stated that it knew of no passive lifts where the edge guard extended below the lowest riser of the steps. Lift-U stated that edge guards on passive lifts should only be required for those portions of the lift that are outside of the vehicle and that any handrails be considered part of the edge guard. It also argued, as did APTA, that the guards

should not be required within three inches of the outer edge of the lift. In the same vein, Braun and NMEDA stated that, for personal use lifts, edge guards should not be required on thirty percent of the platform on one side. The basis for both suggestions was that lifts are commonly designed without a continuous edge guard to facilitate the loading and unloading of the lift passenger when space is limited. Braun and NMEDA also alternatively argued for a reduction in minimum height from the proposed 1.5 inches to 0.75 inches.

The edge guard specifications in today's rule have been amended in response to comments. The practice of ending edge guards short of the outer edge of the platform and reducing the length of the edge guards on one side of the platform allows a lift occupant to turn his or her mobility device when space directly in front of the platform is limited. Accordingly, we have decided to require edge guards be present and continuous along the sides of the platform to within 3 inches from the outer platform edge. In many cases this will be less than the 30% reduction common on many lifts. However, we are concerned that allowing up to a 30% reduction in coverage along the side of the platform could compromise wheelchair retention on the lift platform. This is precisely the type of situation we wish to avoid. Some present lift designs offer lifts where a significant portion of the edge guard stows when the lift is at ground level. Other designs feature stowable edge guards that incorporate at least 30% of the entire edge guard. Such systems are permissible under today's rule as long as the edge guard is fully deployed by the time the lift is more than 3 inches above the ground. We believe this will allow those types of lift designs where additional turning space is desirable without compromising the safety of the lift occupant.

Handrails would also be allowed to operate as an edge guard as long as the handrail provides a continuous surface along and adjacent to the side of the platform parallel to the direction of wheelchair movement during loading and unloading. Likewise, as noted in the SNPRM, the interior structure of the stairwell in an over-the-road bus may serve as an edge guard for those lifts. However, we note that the restriction on gaps, transitions and openings discussed above would apply to these surfaces.

We have decided against reducing the minimum height requirement for edge guards on private use lifts. We do not believe a minimum height of one and one-half inches is excessive. Both the

FTA and SAE guidelines specify a minimum height of 1.5 inches, and we are unaware of any problems associated with meeting these guidelines. Additionally, commenters failed to provide any rationale as to why a shorter edge guard was needed or how it would adequately protect a lift user.

6. Wheelchair Retention

In the SNPRM, we proposed that lifts be equipped with a wheelchair retention device that can keep a wheelchair upright throughout the range of lift operation and can sustain a direct force of 7,117 N (1,600 lb). We proposed testing the device both dynamically (impact tests) and statically (overload test) since the two tests replicate different conditions. The dynamic impact test was designed to ensure that the wheelchair could not climb a barrier, while the static test measures a restraining device's structural integrity. We proposed running the dynamic impact test by impacting an empty wheelchair into the barrier when the platform is level with the ground. We would run the proposed static test by applying a load against the retention device and then examining it for separation, fracture or breakage. We proposed a separate dynamic test for rotary lifts whereby both barriers are impacted at a point in lift operation between the ground and vehicle floor.

Lift-U and APTA stated that the SNPRM did not clearly indicate whether the wheels of the wheelchair had to remain on the lift platform during the entire test sequence for both tests, or whether they only had to be in contact with the platform at the end of the test. Trolley & Transport suggested that the wheelchair retention device be at least as high as the average armrest, approximately 635–762 mm (25–30 in), in order to prevent a wheelchair occupant from being tipped out of the wheelchair and off the platform. It also recommended that the dynamic test be conducted using the 95th percentile adult male test dummy and 5th percentile adult female test dummy to assure that a wheelchair occupant would not be thrown off the lift even though the wheels of the mobility aid remained on the platform.

Lift-U also indicated that allowing the wheelchair retention test to be performed in one direction when a single loading direction is specified in the owner's manual is contrary to the requirements of the ADA. Braun commented that the compliance tests for the wheelchair retention device should be conducted using the ISO/SAE surrogate wheelchair. NMEDA also advocated that, for personal use lifts, the

outer barrier be required to be fully in position before the lift can be raised or lowered. It stated that this requirement is particularly important for personal use lifts because those systems almost never have a wheelchair securement device to keep the wheelchair on the lift in the absence of an outer barrier. Ricon believed we should mandate the use of an occupant restraint system for the lift as is currently specified in the Canadian Standards Association D-409.

APTA doubted whether any existing lifts, particularly those installed on paratransit vehicles, have retention devices that could withstand the application of 7,117 N (1,600 lbf) without significant redesign. Braun also believes, as does NMEDA, that the static 7,117 N (1,600 lbf) overload test is sufficient for personal use lifts and that no dynamic test is needed. It argues that the dynamic test will require systems, such as belts or taller outboard roll stops, which are cumbersome and generally incompatible with the smaller, personal use lifts.

We have decided to adopt the wheelchair retention device requirement as proposed in the SNPRM. We note that in many instances the retention device will simply be the lift's outer barrier, and, if applicable, the inner roll stop discussed after this section. The test device need not maintain full contact with the lift platform throughout the wheelchair retention dynamic test. It must remain upright at the conclusion of the test.

We have decided against testing the retention device with a 5th percentile adult female test dummy or a 95th percentile adult male test dummy. When developing the wheelchair retention test, we ran the test with the wheelchairs empty and loaded with 102 kg (225 lb) of ballast. The empty wheelchairs were the most likely to climb the barrier. Transport & Trolley is correct that a loaded wheelchair is more likely to tip over the outer barrier; however, we believe the requirement that the wheelchair remain upright at the conclusion of the test should require designs that are unlikely to tip an occupant out of the wheelchair. The only way to guarantee that a wheelchair does not tip over the outer barrier is to require the type of high barrier advocated by Trolley & Transport or to require an occupant restraint system. We are not mandating the use of an occupant restraint system, as specified in the Canadian Standards Association D-409, because we believe such a requirement is unduly design restrictive. Likewise, we have decided against adopting the suggestion that the retention device be as high as a

handrail. We are not persuaded that such restrictions on design are warranted. Rather, we believe any device that can meet the applicable static and dynamic tests used to test for compliance will be amply safe. We note that while we are not imposing a requirement that the outer barrier be fully positioned before a lift can be raised or lowered, rather, we are adopting a requirement that the wheelchair retention device must be fully deployed whenever the lift platform is more than 75 mm (3 in) from the ground.

We note that the ADA does not apply to private use lifts. Accordingly, allowing private use lifts without an inner roll stop if the lift manufacturer specifies that rearward loading is required is not inconsistent with the requirements of the ADA.

We have decided against using the ISO surrogate wheelchair because that wheelchair is not powered. Our test procedure requires the technician to maintain power until all wheelchair motion other than the drive wheels has ceased. This requirement is included in the test procedure to determine whether a powered wheelchair is capable of climbing the barrier. Accordingly, it is imperative that we specify a testing device that is power driven.

We do not know why APTA believes none of the lifts currently installed on its' members buses could not meet the 7,117 N (1,600 lbf) static overload test. This test is based on the existing FTA guidelines, which should apply to many of APTA's members. Additionally, no lift manufacturer objected to the force levels proposed in the SNPRM. Absent any evidence that the proposed force level is excessive, we have decided to adopt the static overload test as proposed in the SNPRM.

7. Inner Roll Stop

We proposed in the SNPRM requiring an inner roll stop to prevent a wheelchair from rolling off the platform's inner edge. For arc lifts, *i.e.*, lifts that move in arcing motion from vehicle edge to a distance away from the vehicle edge during operation, this device prevents the lift occupant from falling off the inner edge. For all lifts, it prevents injuries due to pinching and shearing of the occupant's legs or feet between the platform and the vehicle. For elevator lifts, *i.e.*, lifts that move vertically during operation, it is possible for the vehicle wall below the wheelchair lift entry door to perform the function of the inner roll stop. Accordingly, we proposed a two-part requirement for inner roll stops to ensure that the inner roll stop has

adequate strength and will be sufficient to prevent pinching of an occupant's feet throughout the range of operations. Tests would be conducted by preventing the wheels of a wheelchair from passing over the inboard edge of the platform when at ground level and by attempting to move the wheelchair toward the roll stop as the lift is operated. We proposed not requiring an inner roll stop on private use lifts as long as the owner's manual specified that rearward loading was required. We requested information whether pinching was possible in rearward-loading lifts.

Braun commented that the compliance tests for the inner roll stop should be conducted using the ISO/SAE surrogate wheelchair. Braun also noted that it was highly unlikely an occupant on a personal lift would be subjected to a pinching risk when using the lift as instructed and in a lift-compatible wheelchair. Lift-U indicated that allowing the inner roll stop test to be performed in one direction when a single loading direction is specified in the owner's manual is contrary to the requirements of the ADA.

We are adopting the inner roll stop requirements as proposed in the SNPRM. We agree with Braun that there is little risk of pinching on a private use lift when that lift is used as directed. However, we believe such a lift would necessitate rearward or sideways loading in order to eliminate the risk of pinching in the absence of an inner roll stop. As noted in the previous section, the ADA does not apply to private use lifts. Accordingly, we do not believe the requirements we have adopted for those lifts are inconsistent with that law. Finally, we have decided against using the ISO surrogate wheelchair for the same reasons provided in our discussion of the wheelchair retention device.

8. Handrails

In the SNPRM, we proposed that handrail displacement be limited to 25 mm (1 in) when a force of 445 N (100 lbs) is applied and to 102 mm (4 in) when a force of 1,112 N (250 lbs) is applied. We believed that it is more appropriate to test at two force levels than at a single force level of 445 N (100 lbs). The purpose of the 445 N (100 lbs) force application is to assure that the handrail is stable and has adequate clearance around it. The 1,112 N (250 lbs) force application's purpose is to assure that the handrail is sufficiently strong to prevent catastrophic failure.

We received only one comment on the proposed handrail requirement. The Oregon DOT objected to a standard that would allow the handrail to bend as that

condition could inhibit the proper operation of the lift. It also noted that if there were extensive movement or rapid distortion of the handrail, even if the handrail did not break, the effect on the lift user could be the same.

The majority of current handrail designs will bend or deflect to some degree. Requiring handrails that do not bend or deflect at all would be costly and would add additional weight to the lift. Handrail deflection is a by-product of the handrail design and material components. We believe the two handrail tests will ensure that both the design and composition of the handrails will be safe without regulating current designs out of existence.

9. Platform Markings on Public Use Lifts

In the SNPRM we tentatively concluded that it is appropriate to require public use lifts be equipped with platform markings so as to provide greater visibility for the edges of the lift, thus reducing the potential for injuries. Throughout the range of operation, all platform edges, the visible edge of the vehicle floor or bridging device, and any designated standing areas would be outlined with markings at least one inch wide and of a color that contrasts with the color of the rest of the platform by 60 percent. These requirements are based on the FTA-sponsored guidelines (section 2.2.9).

We received no comments on this portion of the proposal. Accordingly, we have adopted the requirement for platform markings as proposed. It only applies to public use lifts. As with the other requirements applicable to lifts suitable for public use, a manufacturer of a lift that is appropriate for installation on an MPV under 4,536 kg (10,000 lb) GVWR may certify compliance with this portion of the standard if it intends to market the lifts as appropriate for use by multiple lift users.

10. Platform Lighting on Public Use Lifts

NHTSA also tentatively concluded in the SNPRM that it is appropriate to require public use lifts be equipped with lighting. We were concerned that without such lighting, a lift user could be injured in poor light conditions. We also believed that the lighting from the vehicle's interior would probably be insufficient to illuminate the lift. Under the proposed standard, based on the FTA guidelines, the vehicle would need lighting sufficient to provide at least 54 lumens per square meter (5 lm/ft²) of luminance on all portions of the lift platform throughout the range of passenger operation. At ground level, all

portions of the lift's unloading ramp would be required to have at least one lumen per square foot of luminance. The agency noted that the current industry standard for lifts in personally-licensed vehicles (SAE J2093) does not require lighting. Moreover, users of personally-licensed vehicles are typically familiar with the use of their lifts and in many cases the user is the operator. Accordingly, we did not propose any lighting requirements for private use lifts. We maintained that these individuals could have lighting installed if they believe it is necessary.

Braun and NMEDA, the only parties to comment on this issue, both supported the proposed lighting requirements, although they stated that the lights need not be mounted directly on the lift and may provide better illumination if installed directly on the vehicle.

We have adopted the lighting requirement as proposed in the SNPRM. Today's rule merely requires the platform of public use lifts be illuminated throughout the range of passenger operation. It does not indicate that the light source must be mounted on the lift. Lighting may be mounted to the vehicle if, along with the lift, the lift manufacturer provides all hardware and detailed installation instructions necessary to install the lighting in a manner that complies with the requirements of the standard. Likewise, the lift manufacturer could specify that the lift was compatible with the lighting package of a particular make/model/year vehicle and provide installation instructions for that vehicle. In either case, compliance with the standard rests with the lift manufacturer, although FMVSS No. 404 will place the burden of compliance with the installation instructions on the vehicle manufacturer.

11. Platform Slip Resistance

A slip resistant platform surface is important to reduce the potential for injuries for both wheelchair and non-wheelchair lift users. The FTA-sponsored guidelines (section 2.2.2) and the ADAAG (49 CFR 38.23(b)(6)) specify that the platform surface should be slip resistant. NHTSA proposed in the SNPRM that the lift platform surfaces have a static coefficient of friction of at least 0.65 when tested, while wet, in any direction.

The proposed test procedure for testing slip resistance was based on the ANSI/RESNA WC-13 test procedure.¹¹

¹¹ *Evaluation of ANSI/RESNA WC/13 to Determine the Coefficient of Friction of wheelchair Lift Platforms*, (July, 1996), Docket No. NHTSA-4511.

The coefficient of friction would be tested by wetting the platform surface in the manner prescribed in the standard. Testing would occur within 30 seconds of wetting the platform surface with distilled water.

Only one commenter, R.C.A. Rubber Co. commented on the proposed platform slip resistance requirement. It stated that the proposed test procedure would not be repeatable. The commenter also acknowledged that all known methods of testing for the wet coefficient of friction for wet surfaces were also non-repeatable and did not offer a better method of testing slip resistance. Rather, it suggested the proposed test method not be adopted as part of the standard.

We disagree that the method of testing for the coefficient of friction is not repeatable and are adopting the requirement as proposed. ANSI/RESNA Standard WC13-1998 accepts the coefficient of friction test proposed in the SNPRM. Based on testing that NHTSA conducted, we made slight modifications to the ANSI/RESNA test procedure to maximize test repeatability. We will consider changing the standard in the future if data indicates that a more repeatable test procedure is available.

E. Structural Integrity

1. Fatigue Endurance

We also proposed two, separate requirements to test for fatigue endurance. The first one was the current SAE recommended practice, which requires the lift to operate through 8,800 cycles; one half of the cycles would be conducted with the lift loaded with 272 kg (600 lb) and one half of the cycles would be conducted with the lift empty (including the stow and deploy operations). The second requirement, which would have applied only to lifts built for public use, would require the lift system to be cycled a total of 31,200 times with one half of the cycles conducted with an empty lift (including the stow and deploy operations) and one half the cycles conducted with a lift loaded to 272 kg (600 lb). We sought comment on whether fatigue endurance should be included as a requirement in the standard.

All commenters offering an opinion on the appropriateness of this requirement supported some type of a fatigue endurance requirement other than Collins, which indicated that the proposed requirement seemed to be a design requirement rather than a performance requirement. However, none of the commenters supported the requirements proposed in the SNPRM.

Stewart & Stevenson supported the adoption of the fatigue endurance requirements set forth in California Title 13. Braun and Ricon suggested the tests be conducted using the lift rated load rather than a 272 kg (600 lb) load. Lift-U noted that there appeared to be a discrepancy between the number of cycles discussed in the preamble and the number of cycles required by the proposed regulatory text. Lift-U also averred that the test be conducted on a test jig rather than on a vehicle because the length of the test is heavily dependent on the cool down period of the lift's intermittent duty power pack.

We are adopting a fatigue endurance requirement for public use lifts that requires a total of 15,600 cycles of operation, with 50% of the cycles in the loaded condition and 50% of the cycles of operation in the unloaded conditions, which includes stow/deploy operations conducted at the same time as the unloaded operations. The requirement for private use lifts is 4,400 operations cycles, with 50% of the cycles in the loaded condition and 50% of the cycles in the unloaded position (including the stow/deploy operations). These are one half the number of cycles set forth in the regulatory text of the SNPRM. While we acknowledge that none of the commenters were particularly happy with the requirement as proposed, we also note that there was no general consensus on a better approach. Given the general support of some type of requirement, as well as the need for lifts to remain fully operable over a long period of time, we determined it was better to proceed with the proposed requirement, as modified, than to drop the requirement altogether.

Various existing standards and procurement guidelines use different combinations of cycles and loads, all of which have both strengths and weaknesses. We have adopted the most meaningful aspects from the various guidelines by adopting the number of fatigue cycles required by both the FTA and California Title 13 and the test methodology recommended by SAE. California Title 13 and the FTA requirements are the same and both apply to public use lifts. They require 600 up/down operations with a load of 272 kg (600 lb) and 15,000 up/down operations with a load of 181 kg (400 lb). Additionally, they require another 10,000 stow/deploy operations. The SAE recommended practice, which applies to private use lifts, requires a total of 4,400 up/down cycles, with one-half of the cycles in a loaded condition and one-half the cycles in an unloaded condition. We believe that the SAE methodology better imitates real world

conditions than the FTA/California Title 13 in that it requires the lift be deployed and lowered to the ground level loading position, loaded, raised to the vehicle floor loading position, unloaded and stowed. The FTA/California 13 requirements do not contemplate any lift operations, other than stowage and deployment, of an unoccupied lift.

While we have adopted the same number of cycles for public use lifts as required by the FTA/California 13 standards, we are requiring that all loaded operations be conducted with a 272 kg (600 lb) load. Because we are reducing the number of occupied lift operations by 50%, we believe requiring all such operations at the higher weight level is justified. For private use lifts, the number of loaded and unloaded cycles mimics the SAE recommended practice.

We do not believe the fatigue endurance requirement amounts to a design requirement. Rather, it tests for the performance of the lift over multiple operations. This approach is consistent with the fatigue requirements of other safety standards like FMVSS No. 106, Brake hoses. Since the fatigue endurance requirement is intended to address the endurance of both the lift and its interface with the vehicle, we believe it is critical to conduct the test with the lift attached to the vehicle. As discussed earlier in this document, lift manufacturers may use whatever means they choose to base their certification that the lift complies with the standard. However, we will run our compliance tests with the lift attached to the vehicle. As discussed later in this document, we will conduct the fatigue endurance test on private-use lifts using a test load of either 181 kg (400 lb) or the lift's rated capacity, whichever is greater. Please refer to that discussion in subpart M, Test conditions and procedures.

As to Lift-U's comment that the test be conducted on a test jig rather than the vehicle to address the possibility of overheating, we note that the potential for the intermittent power pack to overheat is not related to whether the test is conducted on a test jig or attached to a vehicle. We require the fatigue endurance test be conducted with the lift attached to a vehicle because this condition more closely replicates real world operating conditions and tests the integrity of the lift/vehicle attachment interface. We note that lift motors are generally not designed to run continuously for long periods of time. If their duty cycle is exceeded, they will heat up and may temporarily shutdown due to overheating. Accordingly, there must be some rest time between cycles.

Today's rule establishes a procedure whereby the lift is cycles in blocks of 10 operations cycles with a minimum cool down period between cycles of one minute. The rest period can be longer than one minute; NHTSA will not determine that a lift is noncompliant simply because thermal overloading of the power pack may sometimes require more than a minute cool down period between blocks of cycles.

2. Proof Load

We have also decided to adopt the proof load requirement proposed in the SNPRM. This requirement, which is tested using static load test II is designed to ensure that the lift continues to operate even when subjected to heavy loads. It is also designed to ensure that the lift's components are sufficiently robust for long-term use and occasional overloading. Comments regarding proof load were aimed at the static load test II requirements and are discussed in that section later in this document.

3. Ultimate Load

The requirement that lifts meet an ultimate load is adopted to ensure the overall structural integrity of the lift. It is tested using static load test III where a 1,089 kg (2,400 lb) weight is placed on public-use lifts and at least a 726 kg (1,600 lb) weight is placed on private-use lifts. The lift is then inspected for breakage. We received considerable comments objecting to the adoption of static load test III and the corresponding requirement for an ultimate load. These comments are addressed in the section discussing static load test III.

F. Platform Free Fall Limits

We proposed limiting the free fall velocity of a failing lift system to 305 mm/s (12 in/s) as the result of a single-point failure. Additionally, any single-point failure could not change the platform's angular orientation by more than two degrees in any direction. Under the proposal, both conditions would need to be met when the lift is under its own power.

While Lift-U supported the proposed vertical free fall limit, it suggested the regulation allow a maximum of 4.8 degrees of angular orientation with respect to the vehicle in the event of a single point failure. This comment mirrors its earlier comment regarding the maximum allowable deflection under normal operating conditions.

We are adopting the free fall limits proposed in the SNPRM. As discussed earlier, we have adopted Lift-U's suggestion that maximum platform deflection be allowed up to 4.8 degrees

for a loaded lift and 1.8 degrees for an unloaded lift. Today's limitation on angular rotation while the lift is in free fall limits overall angular rotation to 6.8 degrees since the limitation on deflection is additional to the 2 degree limitation on rotation as a result of free fall.

G. Control Systems

Under the SNPRM, each system would need to have a "power" switch, a "deploy" or "unfold" switch, an "up" switch and a "down" switch (rocker switches are considered two switches), and a "stow" or "fold" switch. The letters would need to be at least 2.5 mm (0.01 in) high, and allow for easy viewing. Controls on public use lifts would need to be illuminated whenever the vehicle's headlights are on and located together in an area where the lift operator has an unobstructed view of the lift and its occupants at all times. We proposed that all controls be activated in a sequential fashion so that no two switches could be operated at the same time. Simple instructions on how to operate the lift's back-up system would be provided near the controls and in English. Any single-point failure in the control system could not prevent operation of the vehicle interlocks. We also considered exempting personal-use lifts from the control requirements. We then sought comment on whether there were any industry-accepted icons or pictographs and whether such icons or pictographs would be helpful. We also sought comment on whether requiring control-switch uniformity and/or a power switch would have prevented any inadvertent deployments or other unsafe situations. Finally, we sought comment on whether the costs associated with control switches would be prohibitive.

While Collins believed a main power switch was probably a good idea, it noted that it did not believe such a switch met the need for safety since it knew of no instances in which an injury occurred on a lift that was not in power mode. It noted that perhaps a better alternative to requiring an "on/off" switch would be to prevent the lift from operating until the door is open and the lift is ready to use. Braun also suggested that personal use lifts had no need of a power switch since power switches for these lifts have historically been incorporated by the lift installer as part of the vehicle interlock system. Braun noted that on personal use lifts power is generally introduced to the lift when the access door is opened, obviating the need for a power switch.

Braun commented that it was impossible to operate a lift if the power

switch could not be activated at the same time as the other control switches since the power must be activated for the lift to work.

Lift-U noted that the proposed requirements for controls reflect the operation of some, but not all, lifts currently in production. It noted that 60% of the 360,000 lifts it has sold since 1982 have simple controls that use the terms "power", "raise", "lower", and "stow". In these lifts, the switches may serve multiple operating functions.

Lift-U and Blue Bird both had questions regarding the proposed requirement that the controls on a public use lift be located in a place where a standing lift operator had an unobstructed view of the lift occupant, and the occupant's wheelchair throughout the range of lift operations. Lift-U noted that such a requirement would prohibit designs where a seated operator, such as a bus driver, could operate a lift. Blue Bird queried whether the requirement applied to controls designed to control backup operation of the lift.

No commenters knew of any icons or pictographs that had been adopted by a voluntary standards group or by the lift industry. Lift-U noted that up and down arrows are sometimes used rather than the words "up" or "raise" and "down" or "lower". Both Ricon and MCI argued that the one-inch minimum lettering requirement was unreasonable. Braun stated that the requirement for controls would add some cost to the lifts but that the increase would not be burdensome.

The requirement in the SNPRM that all functions must be activated in a momentary fashion presupposes that once the force to the switch is removed the action controlled by the switch will also cease. This likely would not be the case with a power switch since it would be awkward to exert pressure against both the power switch and some other switch to operate the lift. Rather than debating whether a power switch can perform a momentary function within the context of today's rule, we have decided to specifically exclude the power switch from the prohibition against simultaneous performance of more than one switch. However, we have decided to retain the requirement that all lift systems come with a separate power control. Since the controls for a private use lift need not all be located together, the power control could be incorporated into the vehicle in such a way as to activate the power by opening the lift access door.

The one-inch height specification in the preamble of the SNPRM was an error. The correct height specification was provided in the draft regulatory

text. That specification was a minimum of 2.5 mm (0.1 in). We believe this minimum height specification is sufficiently large to be legible without being unduly design-restrictive, and we have adopted it in today's rule. Since there are no industry accepted icons or pictographs, we have decided to retain the proposed wording for the control functions. We believe that uniformity in the area of control functions is critical for commercial lifts, where there will likely be more than a single lift operator, and will provide the users of personal lifts with some assurance that they will be able to operate a lift other than their own if the circumstances so require. Accordingly, we have decided against adopting Lift-U's suggestion that arrows be allowed in lieu of specific wording. We also note that Lift-U may need to change some of its lift designs in order to bring its lifts into compliance with the standard.

We have also added a requirement that the manufacturer's rated weight capacity of a private-use lift be placed at the controls. We have added this requirement so that the lift user will know immediately whether the lift is sturdy enough to accommodate the weight of the lift user and wheelchair.

Finally, we agree that there is no need to require controls on public use lifts be placed in such a manner that the lift operator has to be standing in order to operate the lift. Under today's rule, a public use lift operator may be seated as long as he has an unobstructed view of the lift occupant and any mobility aid while the lift is being operated.

H. Jacking Prevention

We proposed that the lift's control system or design prevent the raising of any portion of the vehicle by the lift system if continued force were exerted in a downward motion after contact with the ground had been made.

The Oregon DOT stated that the standard should prevent jacking and that resistance should be based on the amount of force needed to keep the lift platform in contact with the ground as the person exits the lift platform. All other commenters addressed the proposed requirement in the context of the proposed "anti-crush" interlock discussed later in this document.

We have decided to retain the requirement that the lift be designed in a manner that prevents it from continuing to exert a downward force when the platform has made contact with the ground. We believe that such a requirement is important to prevent undue strain on the lift's operating components. As many lifts have a gravity-down design, they will

automatically stop once they impact the ground or another hard surface. We do not believe it is necessary to specify a particular force application. Either the lift stops when it meets the ground or it doesn't. While the SAE recommended practice specifies that a lift with a power-down system cannot exert a force greater than the weight of the lift components, this is simply another way of saying that the lift can't move or lift the vehicle up. We have, however, decided against adopting the related proposed anti-jacking, anti-crush interlock. Our rationale for dropping that proposed requirement is discussed more fully later in this document.

I. Backup Operation

We also proposed in the SNPRM that platform lifts have a manually-operated back-up system that allows for full use of the lift in the event of a power failure. The back-up would allow for disembarkment as well as lift stowage. Under the proposal, operating instructions would need to be located near the control panel and in the vehicle owner's manual.

Lift-U posited that a lift need only be operable in a loaded condition when the lift was being lowered. It noted that in the event of a power failure, the need was to get a disabled occupant out of the vehicle and to stow an empty lift so that it would not create a dangerous condition. Accordingly, it believed there was no reason to require that a loaded lift work in an upward direction during backup operations.

The back-up operation is not intended as a substitute for normal operation of the lift. Accordingly, we agree with Lift-U that there is no need for the lift to be operable in the upward direction when loaded. The wording in the regulatory text has been changed to state that only an unloaded lift need be operable when lifting the platform from the ground.

J. Interlocks

In the SNPRM, we proposed ten, separate interlocks. Since the comments focused on discrete groups of interlocks, they are identified and discussed below. We sought comment on whether we should specify a means of determining when a lift surface is occupied, and if so, how; and whether there are means, other than force or weight detection, already being used or that manufacturers intend to use to determine resistance and occupancy.

Some comments applied generally to most or all of the proposed interlocks. For example, Lift-U requested that we make it clear that an interlock may be a design feature that prevents a particular action. The Michigan DOT,

while supportive of the use of interlocks, stated that we should provide an option to allow a person to override all interlock systems in an emergency situation. All of the commenters supported the specification of a specific force necessary to actuate the interlocks designed to detect a lift occupant or bystander. NJ Transit asked that NHTSA take into account the increased resistance necessary for normal operation of the wheelchair retention device as the lift ages. It was concerned that if the resistance were set too low, the interlocks would trigger increasingly easily as the lift ages. Some commenters also suggested we specify those portions of the platform, bridging device, and vehicle floor that are affected by an interlock.

The first proposed interlock would prevent forward and rearward movement of the vehicle when the lift is not stowed. The second interlock would prevent deployment of the lift unless the lift access door is open and some affirmative action has been taken to prevent the vehicle from moving, such as setting the parking brake.

The Wisconsin DOT appeared to believe the interlocks designed to prevent vehicle movement when the lift is in use or lift usage when the vehicle is in motion were required to be tied to the vehicle parking brake. Accordingly, it asked how to prevent the vehicle from being driven once the parking brake was released, even though the lift was not stowed. Bendix, NMEDA, and an individual commenter indicated that it should be allowable to link the interlocks to the service brakes. Bendix noted that actuation of the parking brake has an effect on the wear of the vehicle air brakes. In order to overcome the problem, air brake manufacturers have developed auxiliary service brake interlock systems that allow the service brake to act in a manner similar to a parking brake. This redundant system allows the vehicle driver to leave the driver's seat without setting the parking brake. NMEDA suggested it might be more appropriate to specify the interlock must function by a means "other than manually applying the vehicles service brakes." ATC suggested the regulatory text require that the interlock prevent accidental or malicious release of the interlock. Collins noted that it knew of no instance in which anyone had been injured by a lift that was operated when the access door was closed, although it had manufactured an externally-mounted lift that could be damaged if it were operated before the access door was opened. Finally, Braun and Ricon suggested that the certification

responsibility for these interlock requirements be assigned to the vehicle manufacturer instead of the lift manufacturer since the interlocks will be vehicle specific.

These two interlocks are already required for public use lifts under ADAAG and are adopted today as part of the final rule. Lift manufacturers need not link the first interlock to the vehicle's parking brake. The SNPRM merely noted that linking the interlock to the parking brake was one means of meeting the proposed requirement. Other designs may be equally effective. Our primary concern is that the interlock not be linked to a service brake that requires the brake pedal be depressed in order to work the brake. The type of system discussed by Bendix, which is based on an auxiliary system that has been built into the service brake, appears to achieve the same goal as engaging the parking brake. Accordingly, the regulatory text has been changed to specify that the transmission be in "park" or "neutral" and the parking or service brakes be applied in a manner other than by the vehicle operator depressing the service brake pedal.

We have decided against shifting the burden of compliance with the requirement for the first interlock to the vehicle manufacturer. We believe it is appropriate that both the lift manufacturer and the vehicle manufacturer bear compliance responsibility. While it is true that the interlocks adopted today may require vehicle specific interfacing, we continue to believe the ultimate burden of compliance best rests upon the lift manufacturer. Under today's rule, the lift manufacturer must provide information identifying the appropriate vehicle make/model/year for a particular lift design. It must also ensure that the installation hardware is fully compatible with those vehicles and that the installation instructions provide detailed guidance. These instructions should include a series of tests designed to confirm that the lift has been properly installed. The vehicle manufacturer is then required to meet all of the lift manufacturer's conditions before certifying that the vehicle meets the requirements of FMVSS No. 404.

While we take note of ATC's comment that the first interlock should be designed so as to prevent accidental or malicious release, we have decided against adopting such a requirement. Certainly, the interlock should be designed in a manner that prevents, at a minimum, accidental release. However, the standard already requires the interlock to meet certain conditions,

such as placing the vehicle in park or neutral and setting the parking or auxiliary service brake, that minimize the risk of an accidental release. We are not persuaded that the risk of a malicious release is sufficiently high to merit adding another restriction on the interlock design.

We also appreciate Collins' comment that it is unlikely an occupied lift would be operated while the access door was closed. The second interlock is not intended to prevent an occupied lift from operating while the access door is closed. Rather, our concern is that the operation of a non-occupied lift could damage the lift, creating a safety risk to future occupants. It is irrelevant whether the access door is open or closed. Both conditions could lead to lift damage. As Collins has noted that it is aware of instances in which such damage occurred, we believe it is appropriate to adopt the second interlock as proposed, except we have dropped the provision addressing the status of the access door.

The third interlock prevents stowage of the lift platform when occupied. Braun noted that it believed an interlock that detects platform occupancy was a good idea, but it should only need to detect a weight greater than 23 kg (50 lb). It also claimed that the interlock should only be required for commercial lifts since a personal lift user would be unlikely to stow the lift while on it.

We have decided to specify a minimum weight of 23 kg (50 lb), as we believe it is unlikely that an occupant less than that weight is likely to be unattended on a lift. Additionally, we have decided to specify a test device that has both the weight and structure to accommodate various interlock technologies.

We believe this interlock is important for both public and private use lifts. We acknowledge that, in many private use applications, the lift operator will be aware that the stow function has been inadvertently actuated because the operator will be the lift occupant. However, depending on the nature and severity of the occupant's disability, the individual may not be able to react in time to prevent a mishap. It is also possible that someone other than the lift occupant may operate a private use lift. In these instances, the risk of improper stowage is akin to the risk faced by public lift users.

The fourth and fifth interlocks prevent movement of the lift, either up or down, if the lift's inner roll stop is not deployed and if the wheelchair retention device is not deployed. Braun and NMEDA opposed the adoption of the interlock designed to prevent

improper stowage of the inner roll stop, noting that it was unaware of any injuries related to such a condition. NMEDA also suggested that the lift be operable in a downward position if the wheelchair retention device fails so that the lift occupant can be unloaded from the vehicle.

We have decided to adopt these two interlocks as proposed in the SNPRM. We note that the fourth interlock is not related to the improper stowage of the inner roll stop, but rather a condition where the inner roll stop is not deployed. On many private use lifts, there may not be an inner roll stop, and no interlock would be required. However, for those lifts that are equipped with an inner roll stop, we believe it is critical that the lift not move up or down unless that inner roll stop is in place. An inner roll stop that is not deployed while the lift is moving creates the same risk of injury as a lift with no inner roll stop. We believe this interlock will prevent injuries resulting from an occupant being crushed or pinched between the lift and the vehicle. We believe NMEDA and Braun's comments were related to the sixth proposed interlock, which prevented stowage of the outer barrier. That interlock is discussed below.

As to NMEDA's suggestion that the lift be operable in a downward position if the fifth interlock is activated, we would expect the lift operator to use the manual back-up operation to unload the lift occupant from either the lift or the vehicle.

A sixth interlock would prevent stowage of the wheelchair retention device unless the platform is within 75 mm (3 in) of the ground. APTA stated that precluding the stowage of the retention device unless the lift were within 75 mm (3 in) of the ground would prevent certain lift designs that stow the lift when they reach the first vehicle step. We recognize that there are over-the-road lift designs in which the front step is less than 75 mm (3 in) from the ground when the lift starts to stow. The proposed interlock could have precluded the use of such a design. However, we have decided not to adopt this interlock because we believe it is redundant of the performance requirement that the outer barrier be fully deployed once the lift is more than three inches from ground level. Accordingly, these types of lift systems may still be used.

The seventh interlock would require the lift to cease movement if it encounters resistance while moving downward. We sought comment on whether we should specify a

quantifiable amount of resistance to trigger the proposed interlock.

While two commenters implicitly supported an interlock to prevent jacking and crushing by asking us to specify a quantifiable amount of resistance to trigger the interlock, the majority of commenters opposed a requirement that would prevent jacking and crushing, arguing that such an interlock would be too costly and unreliable since the sensor would have to detect any obstructions under the platform. Stewart & Stevenson noted that in its experience these types of interlocks were extremely unreliable as they were constantly exposed to adverse environmental conditions. The commenters also noted that an anti-jacking device was not needed since the majority of lifts are gravity-down designs that cease movement once they contact a firm surface. Braun claimed that the relatively slow operating velocity of six inches per second was sufficient to allow bystanders to move out of the way of the lift, obviating the need for an interlock designed to prevent crush injuries.

Recognizing the significant design problems associated with such an interlock, we have decided against adopting it as part of the final rule. We are not confident that it would be possible to design an anti-crushing interlock that would be sufficiently robust to operate for any reasonable period of time. Additionally, we believe the performance requirements preventing anti-jacking and maximum operating velocity sufficiently protect against the risk of injury the interlock was intended to address. We note that we do not believe a system designed merely to prevent further downward movement of the lift once it has reached the ground poses the same problems. Such a system could use a simple force sensor that indicates a significant amount of resistance against the platform. It is for this reason that we have retained the requirement that the lifts come equipped with an anti-jacking mechanism as discussed earlier in this document.

The eighth and ninth interlocks would prevent deployment of an occupied outer barrier or inner roll stop when occupied. The last interlock would preclude downward movement of the lift when both the lift platform and the vehicle floor or the lift's bridging device are occupied. We sought comment on whether anyone knew of injuries attributable to improperly stowing inner roll stops.

Stewart & Stevenson noted that an interlock that would prevent the lift from moving down when both the lift

and the bridging device is occupied would require the development of new technologies. Braun commented that no interlocks were needed to detect occupancy on the inner roll stops, the vehicle floor or a bridging device because the activation of the threshold warning alarm would notify both the lift user and operator that loading was not complete. In a similar vein, the Michigan DOT stated that it believed these interlocks could be handled with a LED lighting system. Braun also noted that it knew of no manufacturer that had incorporated an interlock design that detected weight on the lift's outer barrier. While it did not object to the requirement of such an interlock, it did state that the absence of such interlocks pointed to the difficulty of designing a system that can detect the presence of any portion of the wheelchair or lift occupant. Braun also suggested the interlock be limited to public use lifts, as an individual would have a good idea of whether he was completely on or off of a lift that the individual used on a regular basis.

We have decided to adopt the eighth and ninth interlocks as proposed in the SNPRM. These interlocks were developed as a direct result of comments on the NPRM. In the comments on that notice, a commenter representing Contra Costa county in California pointed out that it knew of cases where the wheels of the wheelchair were on the outer barrier while the lift was operated and the lift occupant was pitched off the lift.

We have decided against adopting the tenth proposed interlock, which would have prevented the downward motion of the platform if the bridging device or threshold area and the lift were occupied. We agree that such an interlock could be both complex and costly to implement. Additionally, we agree that the threshold-warning alert largely obviates the need for this interlock.

K. Operations Counter

In the SNPRM, we tentatively proposed requiring an operations counter so that scheduled maintenance could be tied to lift use. We sought comment on the need for an operations counter as part of a standard.

We received comments both supporting a requirement for an operations counter and opposed to such a requirement. Collins equated an operations counter with an odometer, noting that it believed basing maintenance on an operations counter was the only effective way to ensure adequate maintenance. Those opposed to such a requirement, including

Stewart & Stevenson, stated that maintenance schedules should be based on the scheduled maintenance for the vehicle to which the lift is attached.

With slight modification, we have adopted the requirement for an operations counter as proposed in the SNPRM. Lift maintenance schedules may be based on vehicle maintenance schedules and/or the number of lift cycles. A lift that is seldom used will require periodic maintenance even though it has relatively few accumulated cycles. In those instances, it may be more appropriate to have the lift maintained at the same time the vehicle is serviced. For other vehicles, more regular maintenance may be required because the lift is subjected to heavier usage patterns. The lift manufacturer will have no way of knowing whether a particular lift is likely to be used rarely or often. Accordingly, we believe it is important that maintenance have some relation to the number of lift cycles. However, we also believe that the lift operator may, at its option, also specify an additional maintenance schedule that is not dependent on the number of lift cycles. The regulatory text governing the information required in the owner's manual insert has been changed to clarify that maintenance schedules must have some relationship to the number of lift cycles indicated by the operations counter.

L. Vehicle Owner's Manual Insert

In the SNPRM we proposed the lift manufacturer would have to provide a vehicle owner's manual insert that specifies the recommended maintenance schedule, lift usage instructions, and, for personal-use lifts, the lift's operating volume and whether rearward loading is required. ATC suggested the requirement specify that all lift materials intended for the ultimate user of the lift be placed together in a pouch that is sent with the lift or attached to the lift in a weatherproof container. We believe that the vehicle owner's manual insert, as well as the installation instructions and any additional documentation would be packaged together and somehow shipped with the lift in a way that the package would not be separated from the lift or damaged. While this could be achieved in that manner suggested by ATC, a lift manufacturer could use another method that works equally well. In any case, we do not believe there is a need to specify exactly how this specification is met.

We have imposed specific requirements for the owner's manual insert so that lift operators know

whether the lift is certified as appropriate for public or private use, and so users of private-use lifts are aware of those aspects of lift design that may affect whether a particular individual should use the lift and how. Accordingly, each insert must state whether the lift is for public or private use. Additionally, inserts for private use lifts must give the platform dimensions, the lift's rated weight capacity, and, in the absence of an inner roll stop, the instruction that the lift be loaded in a rearward direction.

M. Installation Instruction Insert

We also proposed in the SNPRM that lift manufacturers include with each set of installation instructions a page specifying a list of vehicle make/models for which the lift was designed, or a list of vehicle characteristics necessary for lift installation consistent with the lift manufacturer's compliance certification (e.g., appropriate vehicle weight, dimensions, structural integrity), and any instructions that must be placed in the vehicle owner's manual, or elsewhere in the vehicle, in order to comply with the requirements of the lift standard once the lift is installed. We requested comment on how common it is not to provide written installation instructions with lifts and whether such a requirement is needed.

The majority of those commenting supported requiring lift manufacturers to provide installation instructions with each lift. Collins noted that all lifts it installed came with installation instructions and that such instructions were necessary. It did not discuss whether every lift came with its own set of instructions or whether instruction manuals, similar to body builder's guides, were available for each lift style. Braun stated that installation instructions are provided with lifts as a matter of course. However, ATC stated that individual lift instructions were unnecessary since the major vehicle manufacturers who regularly install lifts install the lifts in accordance with a protocol that has been approved by the lift manufacturer; additional instructions are only provided when there are changes in the lift equipment or the existing protocol needs to be changed.

We have decided to require installation instructions for each lift. The process of providing instructions with each lift is fundamentally the same as the requirement that incomplete vehicle manufacturers provide subsequent manufacturers with an incomplete vehicle document (IVD). In such cases, each incomplete vehicle must come equipped with an IVD;

however, the incomplete vehicle manufacturers also provide body builder guides that go into considerably more detail than the IVD. Likewise, in this instance we expect lift manufacturer to continue training its installers and to provide ancillary documentation such as a body builder guide that need not accompany every lift. However, installation instructions need to be complete and must identify the vehicle make/model/year appropriate for the particular lift. The instructions must also state, on the cover or first page, whether the lift has been certified for public or private use, and, in the case of those certified for private use, the lift's rated capacity. Lift manufacturers may reference more detailed instructions in the installation instructions if including the highly detailed instructions for each lift is unwieldy. However, those more detailed instructions must be made available to each lift installer using the manufacturer's lift.

N. Test Conditions and Procedures

As discussed in the SNPRM, we believe that tests that may have an effect on the vehicle/lift interface (*i.e.*, inner roll stop, static load test I, fatigue endurance, and static load test II) would likely need to be performed with the lift attached to the vehicle, while other tests could likely be performed on a test jig. We sought comment on the estimated costs of the proposed compliance tests, including the three static load tests. We also sought comment on how lift manufacturers currently test for compliance with the ADAAG requirements and whether the proposed static load tests would be sufficient to allow a manufacturer to verify compliance with the ADAAG requirements.

Several commenters, including Stewart & Stevenson, Provost, and Lift-U stated that the testing costs associated with compliance will be significantly greater than contemplated by NHTSA in the SNPRM and preliminary regulatory evaluation. Braun and Ricon indicated that the additional cost would be nominal. MCI asked if finite element analysis was an acceptable alternative to the dynamic tests.

Braun averred that all performance criteria should be based on the lift's rated capacity rather than requiring that all lifts accommodate a 272 kg (600 lb) load (or a multiplier thereof in the case of static load tests II and III). Braun noted that lifts designed for minivans are generally rated at no more than 181 kg (400 lb). Because an individual with a combined wheelchair/body weight in excess of 181 kg (400 lb) is generally

required to purchase a larger vehicle to accommodate the user's size.

While lift manufacturers are free to use whatever methods they wish to determine whether the lift complies with FMVSS No. 403, we will conduct all dynamic tests in the manner specified in the regulatory text. For some of the tests, a finite element analysis may sufficiently assure manufacturers that their lifts can meet the test conditions specified in this rule. For other tests, such as static load tests I and II, we believe it is unlikely that such an analysis would provide adequate assurances since those tests are designed to assure that the lift is fully functional. In any case the determination of how much and what type of testing is required to meet the manufacturer's good faith determination of compliance ultimately rests with the manufacturer.

The proposed requirement that all lifts be tested with a 272 kg (600 lb) mass, or multiplier thereof, was based on our belief that many lift users are likely to approach a 272 kg (600 lb) weight. As an example, this mass requirement is approached by two separate potential weight combinations: that of a 99th percentile male, weighing 109 kg (241 lb), with a powered wheelchair, weighing 113 kg (250 lb), for a total weight of 222 kg (491 lb); and that of a 99th percentile male in a manual wheelchair and an attendant (245 kg (540 lb)). While these examples are below the 272 kg (600 lb) limit, in some cases people and wheelchairs will weigh more. Additionally, industry standards and the ADA require a 272 kg (600 lb) lifting capacity. However, we recognize that in many instances the combined wheelchair/occupant weight will be considerably smaller than 272 kg (600 lb). A child in a manual wheelchair, even if attended on the lift by a full-sized adult, would likely weigh less than 135 kg (300 lb). Likewise, a full-size adult with a manual wheelchair and no attendant would easily weight less than the 181 kg (400 lb) to which many personal use lifts are currently rated. We believe these smaller lifts serve an important function in providing individuals with lifts that meet their particular needs both in terms of load-bearing capacity and increased vehicle choice.

Accordingly, we are adopting a definition of a standard load in today's rule. For public-use lifts, the standard load will remain 272 kg (600 lb). We believe this degree of load bearing capacity is critical for lifts that are not custom ordered to meet a particular person's individual needs. However, for private-use lifts, the standard load will

be the lift's rated capacity or 181 kg (400 lb), whichever is greater. We are specifying a minimum load bearing capacity because we believe any lift should be able to accommodate 181 kg (400 lb). We are unaware of any lift designs that are not rated to at least 181 kg (400 lb). We are not simply setting the standard load at 181 kg (400 lb) because we are also aware that many personal use lifts are rated at a higher weight and that many individuals require a sturdier lift. Since the standard load is used to mimic weights likely to be placed on a lift during actual operations, or as a basis for determining whether sufficient safety factors have been incorporated into a lift's design, we believe the sturdier lifts should be tested in a manner consistent with their rated capacity.

A detailed discussion of the costs associated with conducting compliance tests is provided later in this document. The other concerns are addressed below in the discussion of each test.

1. Test Devices

In the SNPRM we proposed using a test pallet designed to mimic the size of a standard powered wheelchair. Its base would be 66 mm × 686 mm (26 in × 27 in). For the static load tests, the pallet would be loaded with rectangular steel plates of uniform thickness with dimensions between 533 mm and 686 mm (21 and 27 in). We received no comments objecting to the suitability of the proposed test pallet and have adopted it as proposed in the SNPRM.

We also proposed using a mobility device for testing that approximates the size and weight of popular powered wheelchairs currently on the market. As discussed earlier in the section addressing outer barriers and retention devices, we have decided against adopting the ISO device, as suggested by Braun, because that device is not powered and thus does not place sufficient force against the retaining devices (outer barriers, inner roll stops, or other retention device) to adequately test those systems. Accordingly, we have adopted the device proposed in the SNPRM.

We have also adopted a test device for testing compliance with the restrictions on gaps, transitions, and openings. This test device consists of a solid, rigid box with a height and width of 17 mm (0.67 in) and a depth of 100 mm (4 in). In order to test for platform occupancy for the interlock tests where such occupancy must be detected, we are specifying a rigid test box (150 × 150 × 300 mm (6 × 6 × 12 in)) with a total weight of 23 kg (50 lb).

2. Static Load Test I—Working Load

Proposed static load test I was an operational test in which the lift would be exercised through its full cycle of movement. The lift would be required to function in both the loaded and unloaded conditions. The loaded condition would be met by placing a 272 kg (600 lb) load on the lift. Testing with an empty platform was specified to ensure that the lift operates properly during that portion of the usage cycle when the lift is not occupied.

The only comments we received regarding this test procedure was the comment by Braun and NMEDA that the test should be conducted using ballast equivalent to the lift's rated capacity rather than the specified 272 kg (600 lb). This comment has already been addressed above. Accordingly, we are adopting the procedure largely as proposed. The only changes are that private use lifts will be tested with a 181 kg (400 lb) load or a load equivalent to the lift's rated capacity, whichever is greater, and the requirement that the lift be stopped mid-way through the lift cycle has been removed. The lift will still be stopped once through the lift cycle, but we do not believe it is necessary to specify where exactly that should occur.

Using the control panel, the test operator will deploy the stowed platform, center the pallet on the lift and center the standard load on the pallet. The lift will then be lowered to the ground level, stopping once during the process. The pallet will be removed from the platform and the lift cycled up, stowed, and cycled back down, stopping once during each up or down cycle. The test pallet will then be reloaded onto the platform that would then be cycled up to the vehicle floor level loading position, stopping once during the cycle. The pallet will be removed and the lift stowed. The power will be turned off and the portions of the test that apply to backup operations will be repeated manually, using the lift's manual backup mode.

3. Static Load Test II—Proof Load

The static load test II requires a test load of three times the standard load appropriate for a lift to be centered on the platform while the lift is at the vehicle floor level loading position. For public use lifts, this load will be 816 kg (1,800 lb). For private use lifts, the load will be at least 544 kg (1,200 lb), but could be more if the lift's rated load is greater than 181 kg (400 lb). This constitutes a change from the test proposed in the SNPRM, which would have required a test load of 816 kg

(1,800 lb) for all lifts. As was proposed earlier, the load would remain on the platform for two minutes, after which it will be removed. The lift and vehicle will be inspected for separation, fractures or breakage, and static load test I will be repeated to ensure that all lift components still function.

Braun and NMEDA stated that the test should be tested on a test jig rather than on a vehicle. NMEDA maintained that the test was impractical if conducted with the lift attached to the vehicle since most vehicle floor structures are not developed to withstand the proposed level of concentrated loading. It stated that the current industry practice is to test lift installation to 125% of the lift manufacturer's rated capacity of the lift. Under current industry practice, the installation is acceptable if there is no permanent deformation of the vehicle floor or other mounting structure. Stewart & Stevenson asked whether it would be allowed to certify compliance using a test jig and have the responsibility of adequate lift-to-vehicle interface borne by the vehicle manufacturer.

We continue to believe static load test II should be conducted with the lift installed on the vehicle. After this test the lift must remain fully operational. Thus, the integrity of the connection of the lift to the vehicle cannot be compromised. As discussed earlier, manufacturers may use whatever means they believe is appropriate to ensure compliance with the standard. Accordingly, it is not necessary for this test to be conducted on every possible vehicle make/model/year for which the lift is appropriate as long as the lift manufacturer is confident that the lift will comply on those vehicles based on its own testing and analysis. However, we will conduct this test with the lift installed on a vehicle that the lift manufacturer has identified as appropriate for the lift. As to NMEDA's request that the load be limited to 125% of the lift's rated capacity, we note that such a requirement would be only nominally more stringent than static load test I. Since the point of this test is to assure that the lift remains fully functional even after it has been exposed to a severe condition, we believe that a test load that is three times the lift's rated capacity better ensures that catastrophic failures will not occur in the real world.

4. Static Load Test III—Ultimate Load

The proposed static load test III was designed to ensure that the lift could support the heaviest wheelchair/user combination without the lift collapsing. Under the proposal, the lift would not

be required to operate, and we anticipated that the size of the load would cause permanent deformation to the lift/vehicle system. The test, as proposed, requires a test pallet and load with a mass of 1,088 kg (2,400 lb) be placed on the lift platform. This weight was the equivalent of four times the minimum lift capacity proposed in the NPRM. The loaded pallet would have been left on the platform for two minutes and then removed. The lift would then have been inspected for separation, fracture, or breakage. The lift was to be tested on a vehicle or a test jig and was not expected to remain operable after the load had been removed. We sought comment on whether the static load test III added safety benefits above and beyond those achieved in static load test II.

Collins, Braun, NMEDA, and Steward & Stevenson all opposed the adoption of the Static load III test, arguing that it was too onerous. Collins noted that the static load test III was effectively a design standard, and that since NHTSA does not require an ultimate load analysis for vehicle structures there appeared to be no need for such a requirement for lifts. Stewart & Stevenson argued that static load test III has no safety benefit above that realized with a combination of static load test II and the finite element analysis already required by the ADAAG regulations and California Title 13. Braun and NMEDA argued that if the requirement were adopted, the test should be based on the rated capacity of the lift. Braun maintained that the fatigue endurance test, when coupled with the other static load tests adequately ensured the lifts were designed with sufficient safety factors.

We do not believe static load test III poses an onerous burden for lift manufacturers. By the same token, we are satisfied that the test is fully consistent with the design strictures of the ADA's implementation regulations. Ultimate strength tests for mechanical systems have long been standard practice.¹² Safety factors between 4 and 12 have traditionally been used for elevators, hoisting equipment, lifting

¹² The ultimate strength is the maximum unit stress that the material or system is capable of withstanding and is based on the product of the working load and a factor of safety. Minimum safety factors do not directly influence how a device performs its intended function. Rather, they serve to control the robustness of a complete device or its components parts, to assure that the device, as manufactured, will meet minimum requirements for safe operation in the intended environment for an assumed minimum service life, and to compensate for the variability of material strength and wear characteristics when average design values are used during the design process.

devices, as well as for the chains, cables, and pulleys incorporated into such devices.

The first formal requirements regarding wheelchair lifts for vehicles were published by the Veterans Administration in the mid-1970s as a set of procurement guidelines. These guidelines, which have served as the basis for many subsequent guidelines for both public and private use vehicles, required a safety factor of six and a working load of 181 kg (400 lb). The ultimate strength test under the DVA guidelines was 1,089 kg (2,400 lb). When the SAE developed its recommended practice for platform lifts, it took into consideration the trend towards heavier, powered wheelchairs and raised the recommended standard load to 272 kg (600 lb). However, it dropped the safety factor to four, maintaining an ultimate test strength of 1,089 kg (2,400 lb). Today's requirement adopting static load test III merely retains these long-standing requirements and assesses the strength of the lift's components in a way that is not already addressed by static load test II or the fatigue endurance test.

ADAAG regulations require a design load for public use lifts of at least 272 kg (600 lb) (49 CFR 38.23). The regulations also specify that working parts that can be expected to wear, such as cables, pulleys, and shafts, upon which the lift depends for support of the load, have a safety factor of at least six. Nonworking parts that are not expected to wear, such as the lift platform, frame and attachment hardware, must have a safety factor of three. Both safety factors are based on the ultimate strength of the particular component's material. A lift designed to meet these requirements should be able to withstand a load of 816 kg (1,800 lb) without separation, fracture or breakage of any portion of the lift. Additionally, those working parts that are expected to wear should be able to withstand a load of 1,632 kg (3,600 lb) without separation, fracture, or breakage. The California Title 13 requirements mirror these requirements.

Safety factors can be specified both as an element of design (design safety factor) and as a functional requirement subject to performance testing (testable safety factor). A design safety factor need not be tested at the level specified in order to provide the requisite level of safety, particularly when multiple design safety factors apply to a single system. In the case of the ADAAG regulations, we do not believe the lift, as a whole, can reasonably be tested at the higher minimum safety factor of 1,632 kg (3,600 lb) (6 times the design load). By the same token, we are

unconvinced that static load test II, which tests the entire lift system at the minimum safety factor of three times the lift's design load, sufficiently guarantees that a lift's movable components are sufficiently robust. The question then becomes how to test for both those components that must have a design safety factor of 6 without unreasonably testing those components that only require a design factor of one-half that amount?

We believe that static load test III, when coupled with the fatigue endurance test, establishes performance requirements that adequately test for the design factors of the ADAAG regulations without imposing an undue burden on lift manufacturers. Non-working parts are actually required to meet a higher testable safety factor than the design factor specified in the ADAAG regulations. Working parts are required to meet a testable safety factor that in static load test III constitutes 67% of the amount specified as a design factor in the ADAAG regulations and must, under static load test II, remain fully operational after being subjected to a load that is 50% of the level specified in the ADAAG regulations. Finally, the fatigue endurance test amply evaluates whether those components likely to wear are suitable for safe operation of the lift in its intended environment, over a long period of time.

As discussed more fully above, we have decided to grant Braun and NMEDA's request that this test be based on a multiplier of the rated capacity of the lift, with a minimum rated load of 181 kg (400 lb). This will make the ultimate strength test load for private use lifts at least 724 kg (1,600 lb) and at least four times the lift's rated load.

5. Interlock Test Procedures

As discussed in the SNPRM, the proposed interlocks needed test procedures if they were to be incorporated into the standard. We have developed test procedures for those interlocks that remain. Testing for the first and second interlocks is as simple as attempting to drive the vehicle when the lift is deployed and attempting to deploy the lift when the vehicle is moving. The third interlock will be tested by placing a 23 kg (50 lb) test load on the lift platform when the lift is in a position in which it can be stowed and then attempting to stow the lift. The fourth interlock will be tested by placing a front wheel of the wheelchair test device on the inner roll stop so as to prevent its deployment and then verifying that the lift cannot move up or down. The interlock testing the wheelchair retention device will be

conducted in the same way, although the device need not be deployed when the lift is within three inches of the ground. The last two interlocks will be tested by placing the front wheel of the wheelchair test device on the inner roll stop or outer barrier and attempting to operate the lift. If the platform is too small to allow only one front wheel to be placed on the inner roll stop or outer barrier, both front wheels may be placed on those devices.

IX. Vehicle Requirements

As discussed in the SNPRM, the proposed vehicle requirements would apply to all motor vehicles equipped with a platform lift. Certification of compliance with the lift standard would rest with the lift manufacturer, and each lift would be marked either "DOT-private use lift" or "DOT-public use lift". However, the vehicle manufacturer would have to certify that it followed all lift installation instructions (including installing the lift only on a vehicle that the lift manufacturer has identified as compatible), placed the required owner's manual insert in the vehicle owner's manual, and installed the control panel in a location specified by the vehicle standard and the installation instructions. The vehicle manufacturer or alterer would also need to assure that it has met the certification requirements in 49 CFR part 567. While the vehicle standard would not impose any new compliance costs, the costs of conducting a recall campaign for non-compliant vehicles would be borne by the vehicle manufacturer or alterer.

In the SNPRM we proposed requiring the platform lift be installed in accordance with the lift manufacturer's instructions, including the lift manufacturer's directions as to the appropriate vehicle type for the lift. Lift manufacturer's instructions could include operational tests to ensure that the lift has been properly installed. The majority of commenters agreed that requiring vehicle manufacturers or alterers to install lifts in the manner set forth in the lift manufacturer's installation instructions would adequately ensure that platform lifts are installed safely. NMEDA noted that lift manufacturers generally provide both instructions and formal training to their franchised dealers and there is a growing tendency to only sell lifts to those dealers who have received formal training. Ricon stated that while generic installation instructions are provided with each lift, variations in vehicle body styles made it impractical to provide specific instructions for every application. Accordingly, it maintained that the lift installer must bear some

responsibility for ensuring the integrity of the lift as installed on the vehicle.

We would agree that the vehicle manufacturer bears some responsibility for ensuring that the lift is installed in a manner that does not negate the lift manufacturer's certification of compliance. Several aspects of FMVSS No. 403 are dependent on the lift/vehicle interface. However, we do not expect a vehicle manufacturer to divine the lift manufacturer's intent on how these interfaces work. Instead, it is imperative that the lift manufacturer provides the vehicle manufacturer with all information and equipment needed to install the lift in a manner that will result in a fully functioning lift. These instructions should include any check tests that are required to verify that the interfacing is proper. We note that the lift manufacturer's greatest security is in highly detailed installation instructions. This is because the vehicle manufacturer must certify that it has followed those instructions when installing the lift. As for the comment that highly detailed instructions that apply to a series of vehicles are more useful than instructions provided with each lift, this issue has already been addressed earlier in this document.

We received no comments on the proposed requirements that the vehicle manufacturer place the owner's manual insert in the owner's manual or that the control panel be installed in a position where the lift operator would have an unobstructed view of the lift and its occupants. Those requirements are adopted as proposed in SNPRM.

Under today's rule, the vehicle manufacturer or alterer will need to ensure that the owner's manual insert, required by the lift standard, is placed in the vehicle owner's manual. If the vehicle does not come with an owner's manual, the vehicle manufacturer should take steps to ensure that the vehicle purchaser receives the insert. This could be achieved by placing the insert in a glove box or by attaching it to the vehicle steering wheel.

For vehicles equipped with a commercial lift, the vehicle manufacturer will need to ensure that the lift controls are installed in accordance with the lift manufacturer's instructions and in a location where the lift operator has an unobstructed view of the lift and its occupants throughout the range of lift operation. The vehicle manufacturer will also need to place the lift operating instructions near the lift control for ready access by the lift operator.

X. Benefits of the Final Rule

NHTSA has not been able to quantify the benefits associated with this rule because the NEISS database lacks adequate descriptive information that would allow us to pinpoint the probable cause of injury. However, there are a number of qualitative benefits associated with today's rule. As an initial matter, today's rule incorporates the most relevant requirements of existing standards and guidelines. Accordingly, manufacturers need only comply with standard to be assured that all applicable requirements are met. This one-stop approach provides a consistent level of safety for all lift users. Today's rule also establishes objective means for determining compliance with the new standards. In many cases the existing standards do not provide an objective means of measurement. Accordingly, lift manufacturers may be in a position where they are unsure whether their lift designs actually meet all the requirements referenced in a particular set of contract specifications. Today's rule removes that doubt. Additionally, based on the ATBCB's performance and design guidelines, NHTSA has developed objective test specifications for platform deflection, static loads, inner roll stops, outer barriers, and slip resistance. These specifications provide an additional level of safety not addressed by existing guidelines. Finally, by adopting the existing guidelines and recommended practices as a safety standard, NHTSA can order the recall of non-compliant lifts, thereby establishing a mechanism for removing unsafe platform lifts from the market.

XI. Costs of the Final Rule

In the SNPRM, we estimated the costs of compliance with the proposed standard at less than \$300 per lift. We believed the amount was so low because the lift requirements are all based on existing industry or governmental standards. However, Transport & Trolley estimated that the average cost of a lift today (not including installation) is about \$3,000 for an active lift, and \$7,000 for a passive lift. It then estimated that the cost to upgrade to the proposed standard would be approximately \$1,000 per lift. It further estimated that the number of lifts affected by a new requirement would be between 15,000 and 20,000 lifts per year.

We believe the total consumer cost of today's rule is between \$3.1 million and \$4.7 million per year. This estimate is based on a cost of \$213 per public-use vehicle and a cost of \$147 per private

use vehicle. A more thorough breakdown of the costs associated with compliance with the new standards may be found in the final regulatory evaluation supporting today's rule.

XII. Miscellaneous Issues

A. Axle Weight Limitations

VanHool stated that the technical requirements would increase the weight of the lift and, consequently, the weight of the vehicle on which the lift is installed. It asked whether Federal axle weight limitations would be adjusted to take into account the increased weight of the lift. NHTSA does not regulate limitations on axle weight. These limitations are imposed by other state and Federal agencies, and we cannot relax those standards for them. We do note that the weight of any lift system, regardless of whether it meets the requirements set forth in today's rule, could have an effect on the vehicle's axle weight. To the extent vehicle operators are concerned that the lifts may require a relaxation of existing axle weight limitations, the operators should raise their concerns with the appropriate regulatory authority.

B. Definitions in the FMVSS No. 403

As with the proposed regulatory text in the SNPRM, the regulatory text adopted today provides for a generic definition of "motor home" that applies to all FMVSS. Previously the term "motor home" was defined in each standard where such vehicles were specifically regulated. As a consequence, we developed two slightly different definitions. We have decided that this approach was potentially confusing. Additionally, we have no basis for using the term differently in different standards. Accordingly, we have added a definition of "motor home" to 49 CFR 571.3, which governs the definition of terms applicable to all safety standards. All standard specific definitions of motor homes have been removed from those standards.

C. Delayed Compliance With the ADA

As noted earlier in this document, several over-the-road bus manufacturers and operators, represented by the ABA and the UMA, raised concerns about whether a new standard would delay full implementation of the ADA to over-the-road vehicle operators. The commenters were concerned that they would be unable to comply with the requirements because lift manufacturers would focus their attention on the development of NHTSA-compliant lifts and would be unable to provide bus operators or manufacturers with lifts

that meet the accessibility requirements issued by the Department of Transportation. They also voiced concerns that vehicle operators would simply not purchase lift-equipped vehicles until the lifts on those vehicles were NHTSA-compliant.

Certainly, NHTSA has no desire to delay the implementation of the ADA accessibility requirements for over-the-road bus operators. However, we believe that such a delay is unwarranted. Nothing in today's rule is inconsistent with the Department's accessibility requirements.¹³ Accordingly, we have no reason to believe lift manufacturers will cease production of lifts that meet the accessibility requirements simply because some minor changes may be required to bring their lifts into full compliance with FMVSS No. 403. Additionally, the NHTSA requirements in FMVSS No. 403 only apply to lifts manufactured after the rule's effective date, and the requirements of FMVSS No. 404 only apply to lift equipped vehicles manufactured after that same date. While NHTSA has the authority to promulgate safety standards for commercial motor vehicles and equipment that are already in use,¹⁴ we are not exercising that authority for these standards. Thus, any lift-equipped over-the-road vehicle manufactured before the effective date of today's rule will not need to be certified as NHTSA compliant. If vehicle operators are concerned they may not take delivery of their vehicles until after the effective date of today's rule, they should specify in their purchase orders that the lifts should comply with NHTSA's requirements. In any case, the burden of compliance with NHTSA's standards rests on the lift and vehicle manufacturers and not on the operators.

XIII. Rulemaking Analyses and Notices

A. Executive Order 12866 and DOT Regulatory Policies and Procedures

NHTSA has considered the impact of this rulemaking action under Executive Order 12866 and the Department of Transportation's regulatory policies and procedures. This rulemaking is not economically significant. It is, however, classified as significant because of the public policy considerations entailed. Accordingly, the Office of Management

and Budget has reviewed this rulemaking document under E.O. 12866, "Regulatory Planning and Review." The rulemaking action has also been determined to be significant under the Department's regulatory policies and procedures. The costs and benefits associated with today's rule have been briefly discussed earlier in this document. For a more detailed analysis, please refer to the final regulatory evaluation supporting today's rule.

B. Regulatory Flexibility Act

We have considered the effects of this rulemaking action under the Regulatory Flexibility Act (5 U.S.C. 601 *et seq.*) This action will not have a significant economic impact on a substantial number of small businesses because it does not significantly exceed existing guidelines, contract specifications and industry recommended practices. As discussed in the final regulatory evaluation, the additional costs imposed by this rule will likely have a disproportionate impact on small businesses. However, small organizations and small governmental units will not be significantly affected by today's rule since the potential cost impacts associated with this rule should only slightly increase the price of new motor vehicles and of platform lifts. A fuller analysis of the impact of today's rule on small businesses, organizations, and governmental units may be found in the final regulatory evaluation.

C. National Environmental Policy Act

NHTSA has analyzed this proposed amendment for the purposes of the National Environmental Policy Act and determined that it will not have any significant impact on the quality of the human environment.

D. Executive Order 13132 (Federalism)

The agency has analyzed this rulemaking in accordance with the principles and criteria contained in Executive Order 13132 and has determined that it does not have sufficient federalism implications to warrant consultation with State and local officials or the preparation of a federalism summary impact statement. The final rule has no substantial effects on the States, or on the current Federal-State relationship, or on the current distribution of power and responsibilities among the various local officials. The final rule is not intended to preempt state tort civil actions.

E. Unfunded Mandate Reform Act

The Unfunded Mandates Reform Act of 1995 requires agencies to prepare a written assessment of the costs, benefits

and other effects of proposed or final rules that include a Federal mandate likely to result in the expenditure by State, local or tribal governments, in the aggregate, or by the private sector, of more than \$100 million annually (adjusted for inflation with base year of 1995). Today's rule will not require the expenditure of resources. This is because the additional incremental costs imposed by the new standards are estimated at \$3.1 million to \$4.7 million per year.

F. Executive Order 12778 (Civil Justice Reform)

This final rule does not have any retroactive effect. Under section 49 U.S.C. 30103, whenever a Federal motor vehicle safety standard is in effect, a state may not adopt or maintain a safety standard applicable to the same aspect of performance which is not identical to the Federal standard, except to the extent that the state requirement imposes a higher level of performance and applies only to vehicles procured for the State's use. 49 U.S.C. 30161 sets forth a procedure for judicial review of final rules establishing, amending or revoking Federal motor vehicle safety standards. That section does not require submission of a petition for reconsideration or other administrative proceedings before parties may file suit in court.

G. Paperwork Reduction Act

Under the Paperwork Reduction Act of 1995, a person is not required to respond to a collection of information by a Federal agency unless the collection displays a valid OMB control number. In the SNPRM, we sought comment on the estimated burden, in terms of labor and cost, to lift manufacturers. We received no comments on the estimated burden. This rule imposes new information collection requirements in that both new regulations would require certain disclosures to third parties.

We are submitting a request for OMB clearance of the collection of information required under today's rules. These requirements and our estimates of the burden to lift and vehicle manufacturers are as follows:

- Estimated burden to lift manufacturers to produce an insert for the vehicle owner's manual stating the lift's platform operating volume, maintenance schedule, and instructions regarding the lift operating procedures: 10 manufacturers × 24 hrs amortized over 5 yrs = 48 hrs per year.
- Estimated burden to lift manufacturers to produce an insert for

¹³ Static load test III measures the strength of the lifts design features differently than is contemplated in the accessibility requirements. This is because the accessibility requirements do not provide any performance criteria. We believe that a lift that can sustain the weight specified in static load test III will be able to meet the design requirements of the accessibility requirements.

¹⁴ For further information on this authority, see 65 FR 41014 (July 3, 2000).

the lift installation instructions identifying the vehicles on which the lift is designed to be installed: 10 manufacturers × 24 hrs amortized over 5 yrs = 48 hrs per year.

• Estimated burden to lift manufacturers to produce two labels for operating and backup lift operation: 10 manufacturers × 24 hrs amortized over 5 yrs = 48 hrs per year.

Total estimated burden = 144 hrs per year.
• Cost to lift manufacturers to produce:

Label for operating instructions	27,398 lifts × \$0.13 per label	=	\$3,561.74.
Label for backup operations	27,398 lifts × \$0.13 per label	=	\$3,561.74.
Owner's manual insert	27,398 lifts × \$0.04 per page × 1 page	=	\$1,095.92.
Installation instruction insert	27,398 lifts × \$0.04 per page × 1 page	=	\$1,095.92.
Total annual cost		=	\$9,315.32.

H. Regulation Identifier Number (RIN)

The Department of Transportation assigns a regulation identifier number (RIN) to each regulatory action listed in the Unified Agenda of Federal Regulations. The Regulatory Information Service Center publishes the Unified Agenda in April and October of each year. You may use the RIN contained in the heading at the beginning of this document to find this action in the Unified Agenda.

I. Plain Language

Executive Order 12866 and the President's memorandum of June 1, 1998, require each agency to write all rules in plain language. Today's rule has been written with that directive in mind. We note that many of the requirements of today's rule are technical in nature. As such, they may require some understanding of technical terminology. We expect those parties directly affected by today's rule, i.e. platform lift manufacturers and vehicle manufacturers to be familiar with such terminology.

J. Executive Order 13045

Executive Order 13045 applies to any rule that: (1) Is determined to be "economically significant" as defined under E.O. 12866, and (2) concerns an environmental, health or safety risk that NHTSA has reason to believe may have a disproportionate effect on children. If the regulatory action meets both criteria, we must evaluate the environmental health or safety effects of the planned rule on children, and explain why the planned regulation is preferable to other potentially effective and reasonably feasible alternatives considered by us.

As noted earlier, this rule is not economically significant. Additionally, this rule will not have a disproportionate effect on children. This rulemaking directly involves decisions based on health risks that affect children only to the extent that a child is the intended user of a platform lift.

K. National Technology Transfer and Advancement Act

Section 12(d) of the National Technology Transfer and Advancement Act (NTTAA) requires NHTSA to evaluate and use existing voluntary consensus standards¹⁵ in its regulatory

activities unless doing so would be inconsistent with applicable law (e.g., the statutory provisions regarding NHTSA's vehicle safety authority) or otherwise impractical. In meeting that requirement, we are required to consult with voluntary, private sector, consensus standards bodies. Examples of organizations generally regarded as voluntary consensus standards bodies include the American Society for Testing and Materials (ASTM), the SAE, and the American National Standards Institute (ANSI). If NHTSA does not use available and potentially applicable voluntary consensus standards, we are required by the Act to provide Congress, through OMB, an explanation of the reasons for not using such standards.

The equipment standard was drafted to include or exceed all existing government (FTA, ADA) and voluntary industry (e.g., SAE) standards. The table in Appendix A shows the source of each requirement in FMVSS No. 403. The reader should note that only three requirements were added by NHTSA that do not already exist in other standards. Of these three, two are based on a comment on the NPRM by a service transportation provider.

Appendix to Preamble

SUMMARY OF REQUIREMENTS IN PROPOSED FMVSS 141, "PLATFORM LIFTS FOR ACCESSIBLE MOTOR VEHICLES" AND THEIR ANTECEDENTS

Requirement	Based on ¹⁶
Threshold warning signal	SAE.
Max. platform velocity	ADA, FTA.
Max. platform acceleration	FTA, ADA, SAE.
Max. noise level	FTA.
Unobstructed platform operating volume	ADA.
Platform surface protrusions	FTA, ADA.
Gaps, transitions and openings	FTA, ADA, SAE.
Platform deflection	FTA, ADA, SAE.
Edge guards	FTA, ADA, SAE.
Wheelchair retention dynamic static	ADA, FTA, SAE.
Inner roll stop	FTA, ADA.
Handrails	ADA, SAE.
Platform markings	FTA.

¹⁵ Voluntary consensus standards are technical standards developed or adopted by voluntary consensus standards bodies. Technical standards

are defined by the NTTAA as "performance-based or design-specific technical specifications and related management systems practices." They

pertain to "products and processes, such as size, strength, or technical performance of a product, process or material."

SUMMARY OF REQUIREMENTS IN PROPOSED FMVSS 141, "PLATFORM LIFTS FOR ACCESSIBLE MOTOR VEHICLES" AND THEIR ANTECEDENTS—Continued

Requirement	Based on ¹⁶
Platform lighting	FTA, ADA.
Platform slip resistance	FTA, ADA.
Platform free fall limits	ADA.
Control systems	FTA, ADA.
Jacking prevention	FTA, SAE.
Backup operation	FTA, ADA, SAE.
Interlocks: original NPRM 5	FTA, ADA.
2 new to the SNPRM	No comparable existing provision.
Owner's manual insert	No comparable existing provision.
Installation instruction insert	SAE.
Static Load Test I, Working Load, lift must operate normally with 600 pound load	FTA, ADA, SAE.
Static Load Test II, Proof Load, lift must sustain a load of 1800 lbs and operate normally after the load is removed. Safety Factor = 3.	FTA.
Static Load Test III, Ultimate Load, lift must sustain a load of 2400 lbs without failure, but does not need to operate after removal. SF=4.	SAE.
Environmental resistance for externally mounted lifts	SAE (based on FMVSS 209).
Fatigue Endurance	FTA, SAE
Operations Counter	FTA (optional).

List of Subjects in 49 CFR Part 571

Imports, Incorporation by reference, Motor vehicle safety, Motor vehicles, Rubber and rubber products, Tires.

In consideration of the foregoing, 49 CFR part 571 is amended as follows:

PART 571—FEDERAL MOTOR VEHICLE SAFETY STANDARDS

1. The authority citation for part 571 of title 49 continues to read as follows:

Authority: 149 U.S.C. 322, 30111, 30115, 30117, 30166 delegation of authority at 49 CFR 1.50.

2. Section 571.3 is amended by adding a definition of "motor home" to section 571.3(b), in alphabetical order, as follows:

§ 571.3 Definitions

* * * * *

¹⁶ "Based on" means that the standard or regulation shown in this column incorporated a requirement for the named area of lift operation. The proposed NHTSA requirement may, or may not be, identical to the requirement in the antecedent standard.

ADA = 49 CFR part 38, Regulations promulgated by DOT to implement the transportation accessibility requirements of the Americans with Disabilities Act, pursuant to guidelines issued by the Architectural and Transportation Barriers Compliance Board.

FTA = Federal Transit Administration Guideline Specifications for Passive and Active Lifts, procurement guidelines.

SAE = Society of Automotive Engineers J2309, "Design Considerations for Wheelchair Lifts for Entry to or Exit from a Personally Licensed Vehicle," an industry consensus voluntary standard, which itself is based primarily on the Department of Veterans' Affairs procurement requirements. The DVA now uses the SAE standard as an alternative to its procurement standard.

(b) Other definitions. As used in this chapter —

* * * * *

Motor home means a multi-purpose vehicle with motive power that is designed to provide temporary residential accommodations, as evidenced by the presence of at least four of the following facilities: Cooking; refrigeration or ice box; self-contained toilet; heating and/or air conditioning; a potable water supply system including a faucet and a sink; and a separate 110–125 volt electrical power supply and/or an LP gas supply.

* * * * *

3. Section 571.105 is amended by removing the definition of *motor home* contained in § 571.105 S4, Definitions.

4. Section 571.201 is amended by removing the definition of *motor home* contained in § 571.201 S3, Definitions.

5. Section 571.205 is amended by removing the definition of *motor home* contained in § 571.205 S4, Definitions.

6. Section 571.208 is amended by removing and reserving § 571.208 S4.2.4.1(a).

7. Section 571.403 is added to read as follows:

§ 571.403 Standard No. 403; Platform lift systems for motor vehicles.

S1. *Scope*. This standard specifies requirements for platform lifts used to assist persons with limited mobility in entering or leaving a vehicle.

S2. *Purpose*. The purpose of this standard is to prevent injuries and fatalities to passengers and bystanders during the operation of platform lifts installed in motor vehicles.

S3. *Application*. This standard applies to platform lifts designed to

carry passengers into and out of motor vehicles.

S4. Definitions.

Bridging device means that portion of a platform lift that provides a transitional surface between the platform surface and the surface of the vehicle floor within the platform threshold area.

Cycle means deploying a platform lift from a stowed position, lowering the lift to the ground level loading position, raising the lift to the vehicle floor loading position, and stowing the lift. The term includes operation of any wheelchair retention device, bridging device, and inner roll stop.

Deploy means with respect to a platform lift, its movement from a stowed position to one of the two loading positions. With respect to a wheelchair retention device or inner roll stop, the term means the movement of the device or stop to a fully functional position intended to prevent a passenger from disembarking the platform or being pinched between the platform and vehicle.

Floor reference plane means the plane perpendicular to the longitudinal vehicle reference plane for platform lifts that deploy from the side of the vehicle or perpendicular to the transverse vehicle reference plane for platform lifts that deploy from the rear of the vehicle, and tangent to the outermost edge of the vehicle floor surface adjacent to the lift platform. (See figure 1.)

Gap means a discontinuity in a plane surface, or between two adjacent surfaces.

Inner roll-stop means a device that is located at the edge of the platform that a passenger or mobility aid must traverse when entering and exiting the

platform from the vehicle floor loading position and that is designed to retain mobility aids on the platform surface during the range of passenger operation.

Lift reference plane means the plane that is defined by two orthogonal axes passing through the geometric center of the platform surface of a platform lift.

One axis is perpendicular to the platform reference plane and the other is parallel to the direction of wheelchair travel during loading of the lift. (See figure 1.)

Loading position means, with respect to a platform lift, a position at which a passenger can either embark or disembark the lift. The two loading positions are at vehicle floor and ground level.

Longitudinal vehicle reference plane means the plane that is perpendicular to the floor reference plane and contains the longitudinal axis of the vehicle when the vehicle body is level and moves along with the vehicle body in response to the loading of the vehicle suspension. (See figure 1.)

Outer barrier is a particular wheelchair retention device that is located on the edge of the platform, is traversed during ground level loading and unloading, and is designed to retain wheelchairs on the platform surface during the range of passenger operation.

Platform means that portion of a platform lift on which the mobility aid or passenger rests while being raised or lowered.

Platform lift means a level change device, including any integration of existing vehicle components, and excluding a ramp, used to assist persons with limited mobility in entering or leaving a vehicle.

Platform reference plane means a plane tangent to the platform surface at its geometric center. (See figure 1.)

Platform surface means the passenger-carrying surface of the lift platform.

Platform threshold area means the rectangular area of the vehicle floor defined by moving a line that lies on the portion of the edge of the vehicle floor directly adjacent to the platform, through a distance of 457 mm (18 inches) across the vehicle floor in a direction perpendicular to the edge. Any portion of a bridging device that lies on this area must be considered part of that area.

Private use lift means a platform lift certified to the requirements for private use lifts and requirements in this standard for all lifts.

Public use lift means a platform lift certified to the requirements for public use lifts and requirements in this standard for all lifts.

Range of passenger operation means the portion of the lift cycle during which the platform is at or between the vehicle floor and ground level loading positions excluding any stow and deploy operations.

Standard test load means a static load or mass centered on the test pallet such that the total combined mass for public-use lifts shall be 272 kg (600 lb), and the total combined mass for private-use lifts shall be the lift manufacturer's stated rated load or 181 kg (400 lb), whichever is greater.

Stow means with respect to a platform, its movement from a position within the range of passenger operation to the position maintained during normal vehicle travel; and, with respect to a wheelchair retention device, bridging device, or inner-roll stop, its movement from a fully functional position to a position intended to allow a passenger to embark or disembark the platform.

Test pallet means a platform on which required test loads are placed for handling and moving.

Transverse vehicle reference plane means the plane that is perpendicular to the floor reference plane and contains the transverse axis of the vehicle when the vehicle body is level and that moves along with the vehicle body in response to the loading of the vehicle suspension. (See figure 1.)

Wheelchair retention device means a device designed to prevent wheelchairs from leaving the edge of the platform used for ground level loading and unloading during the range of passenger operation.

S5. Incorporation by reference.

S5.1 The Society of Automotive Engineers (SAE) Recommended Practice J578, revised June 1995, "Color Specification" (SAE J578, rev. June 95) is hereby incorporated into S6.1.4 by reference.

S5.2 The Society of Automotive Engineers (SAE) Recommended Practice J211/1, revised March 1995 "Instrumentation for Impact Test—Part 1—Electronic Instrumentation" (SAE J211/1, rev. Mar 95) is hereby incorporated into S6.2.3 by reference.

S5.3 The American Society for Testing and Materials (ASTM) Recommended Practice B456–95 "Standard Specification for Electrodeposited Coatings of Copper Plus Nickel Plus Chromium and Nickel Plus Chromium" (ASTM B456–95) is hereby incorporated into S6.3.1 by reference.

S5.4 The Rehabilitation Engineering and Assistive Technology Society of North America (ANSI/RESNA) Standard WC/Vol.1–1998 Section 13,

"Determination of Coefficient of Friction of Test Surfaces" (ANSI/RESNA WC/Vol.1–1998, sec. 13) is hereby incorporated into S7.2.2 by reference.

S5.5 The American Society for Testing and Materials (ASTM) Recommended Practice B117–97 "Standard Practice for Operating Salt Spray (Fog) Apparatus" (ASTM B117–97) is hereby incorporated into S7.3.2 by reference.

S5.6 The Director of the Federal Register approved the materials incorporated by reference in accordance with 5 U.S.C. 552(a) and 1 CFR part 51 (See § 571.5 of this part). Copies of the materials may be inspected at NHTSA's Technical Reference Library, 400 Seventh Street SW., Room 5109, Washington, DC or at the Office of the Federal Register, 800 North Capitol Street, NW., Suite 700, Washington, DC.

S5.6.1 The SAE materials referred to in S5.1 and S5.2 are available from the Society of Automotive Engineers, Inc., 400 Commonwealth Drive, Warrendale, PA. 15096.

S5.6.2 The ASTM materials referred to in S5.3 and S5.5 are available from ASTM International, 100 Barr Harbor Drive, PO Box C700, West Conshohocken, PA 19428–2959.

S5.6.3 The ANSI/RESNA materials referred to in S5.4 are available from RESNA, 1700 North Moore St., Suite 1540, Arlington, VA 22209–1903.

S6. Requirements.

(a) Each platform lift must comply with the requirements for private use lifts or public use lifts and with the requirements for all lifts.

(b) Each public use lift must

(1) Comply with the requirements for public use lifts and with the requirements for all lifts.

(2) Bear a label with the words "DOT—Public Use Lift" as certification of compliance with the requirements specified in paragraph S6(b)(1).

(c) Each private use lift must

(1) Comply with the requirements for private use lifts and with the requirements for all lifts.

(2) Bear a label with the words "DOT—Private Use Lift" as certification of compliance with the requirements specified in S6(c)(1).

(d) Platform lifts suitable for installation on buses, school buses, and MPVs other than motor homes with a GVWR greater than 4,536 kg (10,000 lb.), except motor homes, must be certified by the manufacturer as meeting the requirements for public use lifts. For platform lifts suitable for installation on all other vehicles, the manufacturer may select the option of certifying compliance with either the public use

lift requirements or the private use lift requirements of this standard at the time it certifies the vehicle and may not thereafter select a different option for the vehicle.

(e) For all lifts, where a range of values is specified, the equipment must meet the requirements at all points within the range.

(f) The test procedures in S7 are used to determine compliance with all requirements, except S6.6, S6.7.5, S6.12 and S6.13.

S6.1 *Threshold warning signal.*

S6.1.1 Except when the platform lift is operated manually in backup mode as required by S6.9, the lift must meet the requirements of S6.1.2 and S6.1.3. The lift is tested in accordance with S7.4 to determine compliance with this section.

S6.1.2. Private-use lifts: Except for platform lifts where platform loading takes place wholly over the vehicle floor, a visual or audible warning must activate if the platform is more than 25 mm (1 inch) below the platform threshold area and portions of a passenger's body or mobility aid is on the platform threshold area defined in S4 when tested in accordance with S7.4.

S6.1.3 Public-use lifts: A visual and audible warning must activate if the platform is more than 25 mm (1 inch) below the platform threshold area and portions of a passenger's body or mobility aid is on the platform threshold area defined in S4 when tested in accordance with S7.4.

S6.1.4 The visual warning required by S6.1.2 and S6.1.3 must be a flashing red beacon as defined in SAE J578, June 95, must have a minimum intensity of 20 candela, a frequency from 1 to 2 Hz, and must be installed such that it does not require more than ± 15 degrees side-to-side head rotation as viewed by a passenger backing onto the platform from the interior of the vehicle. If a lift has only a visual alarm and the lift manufacturer specifies that the passenger must load onto the platform in a forward direction from the vehicle floor, the visual alarm must be located such that it does not require more than ± 15 degrees side-to-side head rotation as viewed by a passenger traversing forward onto the platform.

S6.1.5 The audible warning required by S6.1.2 and S6.1.3 must be a minimum of 85 dBA between 500 and 3000 Hz.

S6.1.6 The intensity of the visual or audible warnings required by S6.1.2 and S6.1.3 is measured at the location 914 mm (3 ft) above the center of the platform threshold area. (See figure 2.)

S6.2 *Platform lift operational requirements.*

S6.2.1 *General.* Throughout the range of passenger operation and during the lift operations specified in S7.6, the platform lift must meet the requirements of S6.2.2 through S6.2.4. These requirements must be satisfied both with and without a standard load on the lift platform, except for S6.2.2.2, which must be satisfied without any load.

S6.2.2 *Maximum platform velocity.*

S6.2.2.1 Throughout the range of passenger operation specified in S7.9.4 through S7.9.7, both the vertical and horizontal velocity of the platform must be less than or equal to 152 mm (6 inches) per second when measured at the geometric center of the platform when the platform is unloaded and at the geometric center of the top, horizontal surface of the standard load specified in S7.1.1 when the platform is loaded.

S6.2.2.2 During the stow and deploy operations specified in S7.9.3 and S7.9.8, both the vertical and horizontal velocity of any portion of the platform must be less than or equal to 305 mm (12 inches) per second.

S6.2.3 *Maximum platform acceleration.* Throughout the range of passenger operation specified in S7.9.4 through S7.9.7, both the horizontal and vertical acceleration of the platform must be less than or equal to 0.3 g after the accelerometer output is filtered with a channel frequency class (CFC) 3 filter. The filter must meet the requirements of SAE Recommended Practice J211/1, rev. Mar 95, with $F_H = 3$ Hz and $F_N = 5$ Hz. The accelerometer is located at the geometric center of the platform and is mounted directly on the platform when it is unloaded and on the geometric center of the top, horizontal surface of the standard load specified in S7.1.1 when the platform is loaded.

S6.2.4 *Maximum noise level of public use lifts.* Except as provided in S6.1.5, throughout the range of passenger operation specified in S7.9.4 through S7.9.7, the noise level of a public use lift may not exceed 80 dBA as measured at any lift operator's position designated by the platform lift manufacturer for the intended vehicle and in the area on the lift defined in S6.4.2.1 and S6.4.2.2. Lift operator position measurements are taken at the vertical centerline of the control panel 30.5 cm (12 in) out from the face of the control panel. In the case of a lift with a pendant control, measurement is taken at the vertical centerline of the control panel 30.5 cm (12 in) out from the face of the control panel while the control panel is in its stowed or stored position. For the lift operator positions outside of the vehicle, measurements are taken at the intersection of a horizontal plane

157 cm (62 in) above the ground and the vertical centerline of the face of the control panel after it has been extended 30.5 cm (12 in) out from the face of the control panel.

S6.3 *Environmental resistance.*

S6.3.1 *Internally mounted platform lifts.* On platform lifts and their components internal to the occupant compartment of the vehicle when stowed, attachment hardware must be free of ferrous corrosion on significant surfaces except for permissible ferrous corrosion, as defined in FMVSS No. 209, at peripheral surface edges or edges of holes on under-floor reinforcing plates and washers after being subjected to the conditions specified in S7.3. Alternatively, such hardware must be protected against corrosion by an electrodeposited coating of nickel, or copper and nickel with at least a service condition number of SC2, and other attachment hardware must be protected by an electrodeposited coating of nickel, or copper and nickel with a service condition number of SC1, in accordance with ASTM B456-95, but such hardware may not be racked for electroplating in locations subjected to maximum stress. The lift must be accompanied by all attachment hardware necessary for its installation on a vehicle.

S6.3.2 *Externally mounted platform lifts.* On platform lifts and their components external to the occupant compartment of the vehicle when stowed, the lift and its components must be free of ferrous corrosion on significant surfaces except for permissible ferrous corrosion, as defined in FMVSS No. 209, at peripheral surface edges and edges of holes and continue to function properly after being subjected to the conditions specified in S7.3. The lift must be accompanied by all attachment hardware necessary for its installation on a vehicle.

S6.4 *Platform requirements.*

S6.4.1 *General.* Throughout the range of passenger operations and during the platform lift operations specified in S7.9.4 through S7.9.7, the platform lift must meet the requirements of S6.4.2 through S6.4.12. The requirements of S6.4.2 through S6.4.6, S6.4.7.4, S6.4.9.4, S6.4.9.5, S6.4.9.6, and S6.4.9.8 must be satisfied both with and without a standard load on the lift platform

S6.4.2 *Unobstructed platform operating volume.*

S6.4.2.1 *Public use lifts.* For public use lifts, the minimum platform operating volume is the sum of an upper part and a lower part (see Figure 3). The lower part is a rectangular solid whose

base is 725 mm (28.5 in) wide by the length of the platform surface, whose height is 50 mm (2 in), and which is resting on the platform surface with each side of the base parallel with the nearest side of the platform surface. The width is perpendicular to the lift reference plane and the length is parallel to the lift reference plane (See Figure 1). The upper part is a rectangular solid whose base is 760 mm (30 in) by 1,220 mm (48 in) long, whose height is 711 mm (28 in), and whose base is tangent to the top surface of the lower rectangular solid (see Figure 3). The centroids of both the upper and lower parts coincide with the vertical centroidal axis of the platform reference plane (see Figure 1).

S6.4.2.2 Private use lifts. For private use lifts, the platform operating volume is as specified by the lift manufacturer and identified in the lift insert to the vehicle owner's manual.

S6.4.3 Platform surface protrusions.

S6.4.3.1 Public use lifts. For public use lifts, except as required for deployment of the wheelchair retention device and inner roll stop, throughout the range of passenger operation, the platform surface may not have protrusions which rise more than 6.5 mm (0.25 in) above the platform surface, measured perpendicular to the platform surface by a device with its base centered between 50–100 mm (2–4 in) from the protrusion. Any cross-sectional dimension of the base of the protrusion measurement device must be greater than or equal to 25 mm (1 in) and less than or equal to 50 mm (2 in).

S6.4.3.2 Private use lifts. For private use lifts, except as required for deployment of the wheelchair retention device and inner roll stop, the platform surface may not have protrusions which rise more than 13 mm (0.5 in) above the platform surface, measured perpendicular to the platform surface by a device with its base centered between 50–100 mm (2–4 in) from the protrusion. All portions of the sides of a protrusion that are between 6.5 mm (0.25 in) and 13 mm (0.5 in) above the platform must have a slope not greater than 1:2, measured with respect to the platform surface at the location of the protrusion. Any cross-sectional dimension of the base of the protrusion measurement device must be greater than or equal to 25 mm (1 in) and less than or equal to 50 mm (2 in).

S6.4.4 Gaps, transitions and openings.

S6.4.4.1 When the platform lift is at the ground level loading position, any vertical surface transition measured perpendicular to the ground over which a passenger may traverse to enter or exit

the platform, may not be greater than 6.5 mm (0.25 in). When the lift is at the vehicle level loading position, any vertical surface transition measured perpendicular to the platform threshold area over which a passenger may traverse to enter or exit the platform, may not be greater than 6.5 mm (0.25 in).

S6.4.4.2 When the platform lift is at the ground or vehicle level loading position, the slope of any surface over which a passenger may traverse to enter or exit the platform must have a rise to run not greater than 1:2 on the portion of the rise between 6.5 mm (0.25 in) and 13 mm (0.5 in), and 1:8 on the portion of the rise between 13 mm (0.5 in) and 75 mm (3 in). The rise of any sloped surface may not be greater than 75 mm (3 inches). When the lift is at the ground level loading position, measurements are made perpendicular to the ground. When the lift is at the vehicle level loading position, measurements are made perpendicular to the platform threshold area.

S6.4.4.3 When the inner roll stop or any outer barrier is deployed, any gap between the inner roll stop and lift platform and any gap between the outer barrier and lift platform must prevent passage of the clearance test block specified in S7.1.3 when its long axis is held perpendicular to the platform reference plane.

S6.4.4.4 When the platform is at the vehicle floor or ground level loading position, any horizontal gap over which a passenger may traverse to enter or exit the platform must prevent passage of a 13 mm (0.5 inch) diameter sphere.

S6.4.4.5 Any opening in that portion of the platform surface that coincides with the unobstructed platform operating volume described in S6.4.2 must prevent passage of a 19 mm (0.75 inch) diameter sphere.

S6.4.4.6 Any gap between the platform sides and edge guards which move with the platform must prevent passage of a 13 mm (0.5 inch) diameter sphere. Where structures fixed to the vehicle are used as edge guards, the horizontal gap between the platform side and vehicle structure must prevent passage of a 6.5 mm (0.25 inch) diameter sphere.

S6.4.5 Platform deflection. The angle of the platform, when stationary, relative to the vehicle floor reference plane may not be more than 1.8 degrees with no load on the platform. The angle of the platform loaded with a standard load, when stationary, may not deflect more than 3 degrees from its unloaded position. The angles are measured between axes perpendicular to the

vehicle floor and platform reference planes.

S6.4.6 Edge guards.

S6.4.6.1 The platform lift must have edge guards that extend continuously along each side of the lift platform to within 75 mm (3 inches) of the edge of the platform that is traversed while entering and exiting the platform from the ground level loading position. The edge guards must be parallel to the direction of wheelchair movement during loading and unloading.

S6.4.6.2 Edge guards that move with the platform must have vertical sides facing the platform surface and a minimum height of 38 mm (1.5 inches), measured vertically from the platform surface.

S6.4.6.3 Except whenever any part of the platform surface is below a horizontal plane 75 mm (3 inches) above the ground, edge guards must be deployed throughout the range of passenger operation.

S6.4.7 Wheelchair retention.

S6.4.7.1 Impact I. Except for platform lifts designed so that platform loading takes place wholly over the vehicle floor, the lift must have a means of retaining the test device specified in S7.1.2. After impact, the test device must remain upright with all of its wheels on the platform surface throughout its range of passenger operation, except as provided in S6.4.7.4. The lift is tested in accordance with S7.7 to determine compliance with this section.

S6.4.7.2 Impact II. For platform lifts designed so that platform loading takes place wholly over the vehicle floor, the lift must have a means of retaining the test device specified in S7.1.2. After impact, the test device must remain upright with all of its wheels on the platform surface, throughout the range of passenger operation, except as provided in S6.4.7.4. The lift is tested in accordance with S7.7 to determine compliance with this section.

S6.4.7.3 Overload. The deployed wheelchair retention device(s) must be capable of sustaining 7,117 N (1,600 lb force) when tested in accordance with S7.13. No separation, fracture, or breakage of the wheelchair retention device may occur as a result of conducting the test in S7.13.

S6.4.7.4 Deployment. Except whenever any part of the platform surface is below a horizontal plane 75 mm (3 in) above the ground, the wheelchair retention device(s) must be deployed throughout the range of passenger operation.

S6.4.8 Inner roll stop.

S6.4.8.1 *Public use lifts.* Public use lifts must have an inner roll stop that meets the requirements of S6.4.8.3.

S6.4.8.2 *Private use lifts.* Private use lifts must:

(a) Have an inner roll stop that meets the requirements of S6.4.8.3; or

(b) Have operating instructions near the lift controls and in the vehicle owner's manual, as specified in S6.7.8 and S6.12.4.3, that contain a warning that wheelchairs should back onto the platform when entering from the ground.

S6.4.8.3 *Requirements.* When tested in accordance with S7.8, platform lifts must have an inner roll stop that provides a means that prevents:

(a) The front wheels of the test device specified in S7.1.2 from passing over the edge of the platform where the roll stop is located, when the lift is at the ground level loading position; and

(b) Any portion of the test device specified in S7.1.2 from being contacted simultaneously with a portion of the lift platform and any other structure, throughout the lift's range of passenger operation.

S6.4.9 *Handrails.*

S6.4.9.1 *Public use lifts:* Public use lifts must have a handrail located on each side of the lift that meets the requirements of S6.4.9.3 through S6.4.9.9.

S6.4.9.2 *Private use lifts:* Private use lifts are not required to be equipped with handrails. Private use lifts that are equipped with handrails must meet the requirement of S6.4.9.3 through S6.4.9.9.

S6.4.9.3 The graspable portion of each handrail may not be less than 762 mm (30 inches) and more than 965 mm (38 inches) above the platform surface, measured vertically.

S6.4.9.4 The cross section of the graspable portion of each handrail may not be less than 31.5 mm (1.25 inches) and more than 38 mm (1.5 inches) in diameter or width, and may not have less than a 3.2 mm (0.125 inch) radii on any corner.

S6.4.9.5 The vertical projection of the graspable portion of each handrail must intersect two planes that are perpendicular to the platform reference plane and to the direction of travel of a wheelchair on the lift when entering or exiting the platform, and are 203 mm (8 inches) apart.

S6.4.9.6 The handrails must move such that the position of the handrails relative to the platform surface does not change.

S6.4.9.7 When tested in accordance with S7.12.1, each handrail must withstand 445 N (100 pounds force) applied at any point and in any

direction on the handrail without more than 25 mm (1 inch) of displacement relative to the platform surface. After removal of the load, the handrail must exhibit no permanent deformation.

S6.4.9.8 When tested in accordance with S7.12.1, there must be at least 38 mm (1.5 inches) of clearance between each handrail and any portion of the vehicle, throughout the range of passenger operation.

S6.4.9.9 When tested in accordance with S7.12.2, each handrail must withstand 1,112 N (250 lb/f) applied at any point and in any direction on the handrail without sustaining any failure, such as cracking, separation, fracture, or more than 102 mm (4 inches) of displacement of any point on the handrails relative to the platform surface.

S6.4.10 *Platform markings on public use lifts.* Throughout the range of passenger operation, all edges of the platform surface, the visible edge of the vehicle floor or bridging device adjacent to the platform lift, and any designated standing area on a public use lift must be outlined. The outlines must be at least 25 mm (1 in) wide and of a color that contrasts with its background by 60 percent, determined according to the following equation:

$$\text{Contrast} = 100 \times [(L1 - L2)/L1]$$

Where:

L1 = luminance of the lighter color or shade, and

L2 = luminance of the darker color or shade. L1 and L2 are measured perpendicular to the platform surface with illumination provided by a diffuse light and a resulting luminance of the platform surface of 323 lm/m² (30 lumen/sqft).

S6.4.11 *Platform lighting on public use lifts.* Public use lifts must have a light or a set of lights that provide at least 54 lm/m² (5 lm/sqft) of luminance on all portions of the surface of the platform, throughout the range of passenger operation. The luminance measured on all portions of the surface of the passenger unloading ramp at ground level must be at least 11 lm/m² (1 lm/sqft).

S6.4.12 *Platform slip resistance.* When tested in accordance with S7.2, the coefficient of friction, in any direction, of any part of a wet platform surface may not be less than 0.65.

S6.5 *Structural integrity.*

S6.5.1 *Fatigue endurance.*

S6.5.1.1 *Public use lifts.* Public use lifts must remain operable when operated through a total of 15,600 cycles: 7,800 unloaded Raise/Lower and Stow/Deploy operations and 7,800 loaded Raise/Lower operations as specified in S7.10. No separation, fracture, or breakage of any vehicle or

lift component may occur as a result of conducting the fatigue test in S7.10.

S6.5.1.2 *Private use lifts.* Private use lifts must remain operable when operated through a total of 4,400 cycles: 2,200 unloaded Raise/Lower and Stow/Deploy operations and 2,200 loaded Raise/Lower operations as specified in S7.10. No separation, fracture, or breakage of any vehicle or lift component may occur as a result of conducting the fatigue test in S7.10.

S6.5.2 *Proof load.* The platform lift must be capable of holding three times the standard load, as specified in S7.11, without separation, fracture, or breakage of any vehicle or lift component. After the test, the lift must pass Static Load Test I as specified in S7.9.

S6.5.3 *Ultimate load.* The platform lift must be capable of holding four times the standard load, as specified in S7.14, without separation, fracture, or breakage of the platform, supporting structure, or lifting mechanism.

S6.6 *Platform free fall limits.* In the event of any single-point failure of systems for raising, lowering or supporting the platform, any portion of the platform, loaded as specified in S7.1.1, may not fall vertically faster than 305 mm (12 in) per second or change angular orientation more than 2 degrees from the orientation prior to the failure. This requirement applies whenever the lift is under primary power source operation or manual backup operation.

S6.7 *Control systems.*

S6.7.1 The platform lift must meet the requirements of S6.7.2 through S6.7.8 and, when operated by means of the control system specified in S6.7.2, must perform the lift operations specified in S7.9.

S6.7.2 The platform lift system must have a control system that performs not less than the following functions:

S6.7.2.1 Enables and disables the lift control system. This function must be identified as "Power" if located on the control. The Power function must have two states: "On" and "Off". The "On" state must allow platform lift operation. When the Power function is in the "On" state, an indicator light on the controls must illuminate. The "Off" state must prevent lift operation and must turn off the indicator light. Verification with this requirement is made throughout the lift operations specified in S7.9.3 through S7.9.8.

S6.7.2.2 Moves the lift from a stowed position to one of the two loading positions. This function must be identified as "Deploy" or "Unfold" on the control.

S6.7.2.3 Lowers the lift platform. This function must be identified as "Down" or "Lower" on the control.

S6.7.2.4 Raises the lift platform. This function must be identified as “Up” or “Raise” on the control.

S6.7.2.5 Moves the lift from a position within the range of passenger operation to a stowed position. This function must be identified as “Stow” or “Fold” on the control.

S6.7.3 Except for the Power function described in S6.7.2.1, the functions specified in S6.7.2 must activate in a momentary fashion, by one switch or by a combination of switches. Verification with this requirement is made throughout the lift operations specified in S7.9.3 through S7.9.8.

S6.7.4 Except for the Power function described in S6.7.2.1, the control system specified in S6.7.2 must prevent the simultaneous performance of more than one function. Verification with this requirement is made throughout the lift operations specified in S7.9.3 through S7.9.8.

S6.7.5 Any single-point failure in the control system may not prevent the operation of any of the interlocks as specified in S6.10.

S6.7.6 *Identification of operating functions.*

S6.7.6.1 Each operating function of each platform lift control must be identified with characters that are at least 2.5 mm (0.1 in) in height.

S6.7.6.2 *Public use lifts:* Public use lifts must have characters that are illuminated in accordance with S5.3 of Standard No. 101, when the vehicle’s headlights are illuminated.

S6.7.7 *Control location for public use lifts:* In public use lifts, except for the backup operation specified in S6.9, all controls must be positioned together and in a location such that a person facing the controls has a direct, unobstructed view of the platform lift passenger and the passenger’s mobility aid, if applicable. Verification with this requirement is made throughout the lift operations specified in S7.9.3 through S7.9.8. Additional controls may be positioned in other locations.

S6.7.8 *Operating instructions:* Simple instructions regarding the platform lift operating procedures, including backup operations as specified by S6.9, must:

S6.7.8.1 Be located near the controls.

S6.7.8.2 Have characters with a minimum height of 2.5 mm (0.1 in) and written in English.

S6.7.8.3 *Public use lifts:* Include the statement “DOT—Public Use Lift”.

S6.7.8.4 *Private use lifts:* Include the statement “DOT—Private Use Lift”, the manufacturer’s rated load for the lift, and, if applicable, instructions indicating that the wheelchair occupant

must back onto the lift when loading from the ground.

S6.8 *Jacking prevention.*

S6.8.1 Except when the platform lift is operated in backup mode as required by S6.9, throughout the lift operations specified in S7.9.4 and S7.9.7, the lift system must meet the requirements of S6.8.2, both with and without a standard load on the lift.

S6.8.2 The control system or platform lift design must prevent the raising of any portion of the vehicle by the lift system when lowering the lift is attempted while the lift is at the ground level loading position.

S6.9 *Backup operation.*

S6.9.1 The platform lift must be equipped with a manual backup operating mode that can, in the event there is a loss of the primary power source for lift operation or a lift malfunction, deploy the lift, lower the loaded platform to the ground level loading position, raise the unloaded platform to the vehicle floor loading position, and stow the lift. During backup operation of the lift, the wheelchair retention device and inner roll stop must be manually deployable and stowable. The operating instructions near the lift controls and in the vehicle owner’s manual insert, as specified in S6.7.8 and S6.12.2, must contain information on manual backup operation which must include manual operation of the wheelchair retention device and inner roll stop during backup operation of the lift.

S6.10 *Interlocks.*

S6.10.1 Except when the platform lift is operated in backup mode as required by S6.9, the requirements of S6.10.2 must be met, both with and without a standard load on the lift.

S6.10.2 The platform lift system must have interlocks or operate in such a way as to prevent:

S6.10.2.1 Forward or rearward mobility of the vehicle unless the platform lift is stowed. The design of this system must be such that it discourages accidental release and does not affect vehicle movement until the lift is stowed until the vehicle is stopped and the lift deployed. Verification with this requirement is made throughout the lift operations specified in S7.9.2 and S7.9.3.

S6.10.2.2 Operation of the platform lift from the stowed position until forward and rearward mobility of the vehicle is inhibited, by means of placing the transmission in park or placing the transmission in neutral and actuating the parking brake or the vehicle service brakes by means other than the operator depressing the vehicle’s service brake pedal. Verification with this

requirement is made throughout the lift operations specified in S7.9.2 and S7.9.3.

S6.10.2.3 Except for platform lifts designed to be occupied while stowed, stowing of the platform lift when occupied by portions of a passenger’s body, and/or a mobility aid. Verification with this requirement is made throughout the lift operations specified in S7.9.7 and S7.9.8, and using the test device specified in S7.1.4 when the device is placed on its narrowest side on any portion of and within the boundaries of the area of the platform that coincides with the unobstructed platform operating volume described in S6.4.2.

S6.10.2.4 Movement of the platform up or down unless the inner roll stop required to comply with S6.4.8 is deployed. When the platform reaches a level where the inner roll stop is designed to deploy, the platform must stop unless the inner roll stop has deployed. Verification with this requirement is made by performing the test procedure specified in S7.6.

S6.10.2.5 Movement of the platform up or down, throughout the range of passenger operation, when the platform surface is above a horizontal plane 75 mm (3 in) above the ground level loading position, unless the wheelchair retention device required to comply with S6.4.7 is deployed throughout the range of passenger operations. Verification of compliance is made using the test procedure specified in S7.5.

S6.10.2.6 In the case of a platform lift that is equipped with an outer barrier, deployment of the outer barrier, when it is occupied by portions of a passenger’s body or mobility aid throughout the lift operations. Verification of compliance is made using the test procedure specified in S7.5.

S6.10.2.7 Deployment of any inner roll stop required to comply with S6.4.8, when the inner roll stop is occupied by portions of a passenger’s body or mobility aid throughout the lift operations. Verification of compliance with this requirement uses the test procedure specified in S7.6.

S6.11 *Operations counter.* The platform lift must have an operation or cycle counter that records each complete Up/Down (Raise/Lower) operation throughout the range of passenger operation. Determination of compliance with this requirement is made during the lift operations specified in S7.9.4 and S7.9.5.

S6.12 *Vehicle owner’s manual insert.* The lift manufacturer must provide with the lift, inserts for the

vehicle owner's manual that provide specific information about the platform lift. The vehicle owner's manual insert must be written in English and must include:

S6.12.1 A maintenance schedule that includes maintenance requirements that have, at a minimum, some dependency on the number of cycles on the operations counter specified in S6.11.

S6.12.2 Instructions regarding the platform lift operating procedures, including backup operations, as specified by S6.9.

S6.12.3 *Public use lifts:* In addition to meeting the requirements of S6.12.1 and S6.12.2, the owner's manual insert for public use lifts must also include:

S6.12.3.1 The statement "DOT—Public Use Lift" on the front cover of the vehicle owner's manual insert; and

S6.12.3.2 The statement "DOT—Public Use Lift" verifies that this platform lift meets the "public use lift" requirements of FMVSS No. 403. This lift may be installed on all vehicles appropriate for the size and weight of the lift, but must be installed on buses, school buses, and multi-purpose passenger vehicles other than motor homes with a gross vehicle weight rating (GVWR) that exceeds 4,536 kg (10,000 lb)."

S6.12.4 *Private use lifts:* In addition to meeting the requirements of S6.12.1 and S6.12.2, the owner's manual insert for private use lifts must also include:

S6.12.4.1 The dimensions that constitute the unobstructed platform operating volume;

S6.12.4.2 The manufacturer's rated load for the lift;

S6.12.4.3 Information on whether a wheelchair user must back onto the platform from the ground level loading position due to the absence of an inner roll stop;

S6.12.4.4 The statement "DOT—Private Use Lift" on the front cover of the vehicle owner's manual insert; and

S6.12.4.5 The statement "DOT—Private Use Lift" verifies that this platform lift meets only the "private use lift" requirements of FMVSS No. 403. This lift may be installed on all vehicles appropriate for the size and weight of the lift, except for buses, school buses, and multi-purpose passenger vehicles other than motor homes with a gross vehicle weight rating (GVWR) that exceeds (4,536 kg) 10,000 lb."

S6.13 *Installation instructions.* The manufacturer of a platform lift must include installation instructions with each lift. Information must be included in the installation instructions that identifies:

S6.13.1 The vehicles on which the lift is designed to be installed. Vehicles may be identified by listing the make, model, and year of the vehicles for which the lift is suitable, or by specifying the design elements that would make a vehicle an appropriate host for the particular lift, and for which the platform lift manufacturer has certified compliance.

S6.13.2 Procedures for operational checks that the vehicle manufacturer must perform to verify that the lift is fully operational. Such checks include, but are not limited to, platform lighting, the threshold-warning signal, and interlocks, including those that interface with vehicle systems.

S6.13.3 Any informational material or labels that must be placed on or in the vehicle in order to comply with the requirements of this standard. Labels must be of a permanent nature that can withstand the elements of the outside environment.

S6.13.4 *Public use lifts:* In addition to meeting the requirements of S6.13.1 through S6.13.3, the installation instructions for public use lifts must also include, on the front cover of the instructions, the statement "DOT—Public Use Lift".

S6.13.5 *Private use lifts:* In addition to meeting the requirements of S6.13.1 through S6.13.3, the installation instructions for private use lifts must also include, on the front cover of the instructions, the manufacturer's rated load for the lift and the statement "DOT—Private Use Lift".

S7. *Test conditions and procedures.* Each platform lift must be capable of meeting all of the tests specified in this standard, both separately, and in the sequence specified in this section. The tests specified in S7.8 through S7.11 are performed on a single lift and vehicle combination. The tests specified in S7.2 through S7.7, and S7.12 through S7.14 may be performed with the same lift installed on a test jig rather than on a vehicle. Certification tests of requirements in S6.1 through S6.11 may be performed on a single lift and vehicle combination, except for the requirements of S6.5.3. Attachment hardware may be replaced if damaged by removal and reinstallation of the lift between a test jig and vehicle.

S7.1 *Test devices.*

S7.1.1 *Test pallet and load.* The surface of the test pallet that rests on the platform used for the tests specified in S7.6 through S7.8 and S7.11 has sides that measure between 660 mm (26 in) and 686 mm (27 in). For the tests specified in S7.6 and S7.7, the test pallet is made of a rectangular steel plate of uniform thickness and the load

that rests on the test pallet is made of rectangular steel plate(s) of uniform thickness and sides that measure between 533 mm (21 in) and 686 mm (27 in). The standard test load that rests on the pallet is defined in S4.

S7.1.2 *Wheelchair test device.* The test device is an unloaded power wheelchair whose size is appropriate for a 95th percentile male and that has the dimensions, configuration and components described in S7.1.2.1 through S7.1.2.10. If the dimension in S7.1.2.9 is measured for a particular wheelchair by determining its tipping angle, the batteries are prevented from moving from their original position.

S7.1.2.1 a cross-braced steel frame;

S7.1.2.2 a sling seat integrated in the frame;

S7.1.2.3 a belt drive;

S7.1.2.4 detachable footrests, with the lowest point of the footrest adjustable in a range not less than 25 mm (1 in) to 123 mm (5 in) from the ground;

S7.1.2.5 two pneumatic rear wheels with a diameter not less than 495 mm (19.5 in) and not more than 521 mm (20.5 in);

S7.1.2.6 two pneumatic front wheels with a diameter not less than 190 mm (7.5 in) and not more than 216 mm (8.5 in);

S7.1.2.7 a distance between front and rear axles not less than 457 mm (18 in) and not more than 533 mm (21 in);

S7.1.2.8 a horizontal distance between rear axle and center of gravity not less than 114 mm (4.5 in) and not more than 152 mm (6.0 in);

S7.1.2.9 a vertical distance between ground and center of gravity not less than 260 mm (10.25 in) and not more than 298 mm (11.75 in);

S7.1.2.10 a mass of not less than 72.5 kg (160 lb) and not more than 86.0 kg (190 lb).

S7.1.3 *Clearance test block for gaps, transitions, and openings.* The clearance test block is made of a rigid material and is 16 x 16 x 100 mm (0.625 x 0.625 x 4.0 in) with all corners having a 1.6 mm (0.0625 inch) radius.

S7.1.4 *Test Device for detecting platform occupancy.* Occupancy of the platform is detected using a 152 x 152 x 305 mm (6 x 6 x 12 inches) rigid box having a total weight of 22.7 kg (50 lb).

S7.2 *Slip resistance test.*

S7.2.1 To determine compliance with S6.4.12, clean any 450mm x 100mm (17.5 in x 3.94 in) section of the platform with household glass cleaner (ammonia hydroxide solution). Wet the cleaned section of the platform by evenly spraying 3 ml (0.10 oz) of distilled water per 100 cm² (15.5 in²) of surface area. Begin the test

specified in S7.2.2 within 30 seconds of completion of the wetting process.

S7.2.2 Use the test procedure defined in ANSI/RESNA WC/Vol. 1–1998, sec.13, except for clauses 5.3, Force Gage and 6, Test Procedure, on the wet section of platform. In lieu of clauses 5.3 and 6, implement the requirements of S7.2.2.1 and S7.2.2.2.

S7.2.2.1 *Force gage.* The pulling force is measured, at a frequency of at least 10 Hz, by a force gauge that has been calibrated to an accuracy of ± 2 percent of the reading in the range of 25N to 100N.

S7.2.2.2 *Test procedure.* Before the test, prepare the surface of the test rubber by lightly abrading with waterproof silicon carbide paper, grade P120, weight D (120 wet and dry). Then wipe the surface clean with a dry cloth or brush. No solvents or other cleaning materials are used. To determine the coefficient of friction for the wet platform section pull the test block, with the test rubber attached, by machine at a rate of 20 ± 2 mm/s. The machine and test block are rigidly linked by a device that exhibits a stiffness greater than or equal to 1×10^5 N/m. Pull the test block for a minimum of 13 seconds. Record the pulling force over the final 10 seconds of the test at a minimum frequency of 10 Hz. Repeat the test at least 5 times on any one area of the platform surface, in a single direction. Calculate the average pulling force for each trial, F_1 through F_n , where n is the number of trials. Measure the weight of the test block with the force gauge and call it F_b . Calculate the coefficient of friction, μ_p , from the following equation:

$$\mu_p = \frac{F_1 + F_2 + F_3 + \dots + F_n}{n \times F_b}$$

S7.3 *Environmental resistance test.*

S7.3.1 Perform the procedures specified in S7.3.2 through S7.3.5 to determine compliance with S6.3.

S7.3.2 Attachment hardware, as specified in S6.3.1, and externally mounted platform lifts or components, as specified in S6.3.2, are tested in accordance with ASTM B117–97. Any surface coating or material not intended for permanent retention on the metal parts during service life are removed prior to testing. Except as specified in S7.3.3, the period of the test is 50 hours, consisting of two periods of 24 hours exposure to salt spray followed by one hour drying.

S7.3.3 For attachment hardware located within the occupant compartment of the motor vehicle and not at or near the floor, the period of the test is 25 hours, consisting of one period

of 24 hours exposure to salt spray followed by one hour drying.

S7.3.4 For performance of this test, externally mounted platform lifts or components may be installed on test jigs rather than on the vehicle. The lift is in a stowed position. The configuration of the test setup is such that areas of the lift that would be exposed to the outside environment during actual use are not protected from the salt spray by the test jig.

S7.3.5 At the end of the test, any surface exposed to the salt spray is washed thoroughly with water to remove the salt. After drying for at least 24 hours under laboratory conditions, the platform lift and components are examined for ferrous corrosion on significant surfaces, *i.e.*, all surfaces that can be contacted by a sphere 2 cm (0.79 in) in diameter.

S7.4 *Threshold warning signal test.*

S7.4.1 Determine compliance with S6.1.2 and S6.1.3 using the test procedure specified in S7.4.2.

S7.4.2 Maneuver the lift platform to the vehicle floor level loading position. Using the wheelchair test device specified in S7.1.2, place one front wheel of the unloaded wheelchair test device on any portion of the threshold area defined in S4. Move the platform down until the alarm is actuated. Remove the test wheelchair wheel from the threshold area to deactivate the alarm. Measure the vertical distance between the platform and the threshold area and determine whether that distance is greater than 25 mm (1 in).

S7.5 *Test to determine occupancy of outer barrier and interlock function.*

S7.5.1 Determine compliance with S6.10.2.5 and S6.10.2.6 using the test procedure in S7.5.2 and S7.5.3.

S7.5.2 Maneuver the platform to the ground level loading position. Locate the wheelchair test device specified in S7.1.2 on the platform. Using the lift control, move the lift up until the outer barrier starts to deploy. Stop the platform and measure the distance between the ground and the upper platform surface and determine whether the distance is greater than 75 mm (3 in).

S7.5.3 Place one front wheel of the wheelchair test device on any portion of the outer barrier. If the platform is too small to maneuver one front wheel on the outer barrier, two front wheels may be placed on the barrier. Using the lift control, attempt to move the platform up. If further upward movement occurs, move the platform up until it stops and determine whether the outer barrier has deployed and caused upward movement of the wheelchair wheel(s) of more than 13 mm (0.5 in).

S7.6 *Test to determine occupancy of inner roll stop and interlock function.*

S7.6.1 Determine compliance with S6.10.2.4 and S6.10.2.7 using the test procedure in S7.6.2 and S7.6.3.

S7.6.2 Maneuver the platform to the vehicle floor level loading position, and position the wheelchair test device specified in S7.1.2 on the platform with the rear wheels facing away from the vehicle. Using the lift control, move the platform down until the inner roll stop starts to deploy. Stop the lift and note that location.

S7.6.3 Reposition the platform at the vehicle floor level loading position. Place one front wheel of the wheelchair test device on the inner roll stop, or along the innermost edge of the platform if the inner roll stop is not accessible. If the platform is too small to maneuver one front wheel on the inner roll stop, two front wheels may be placed on the inner roll stop. Using the lift control, move the platform down until the inner roll stop starts to deploy. Determine whether the platform has stopped and whether the inner roll stop has deployed, causing upward movement of the wheelchair wheel(s) of more than 13 mm (0.5 in).

S7.7 *Wheelchair retention device impact test.*

S7.7.1 Determine compliance with S6.4.7.1 and S6.4.7.2 using the test device specified in S7.1.2, under the procedures specified in S7.7.2 and S7.7.3.

S7.7.2 Conduct the test in accordance with the procedures in S7.7.2.1 through S7.7.2.5 to determine compliance with S6.4.7.1. In the case of private use lifts, perform both S7.7.2.5(a) and (b), unless the operating directions specify a required direction of wheelchair movement onto the platform. When a direction is indicated in the operating instructions, perform the procedure specified in S7.7.2.5(a) or (b) with the test device oriented as required by the operating instructions.

S7.7.2.1 Place the lift platform at the vehicle floor loading position.

S7.7.2.2 If the wheelchair retention device is an outer barrier, the footrests are adjusted such that at their lowest point they have a height $25 \text{ mm} \pm 2 \text{ mm}$ ($1 \text{ in} \pm 0.08 \text{ in}$) less than the outer barrier. If the wheelchair retention device is not an outer barrier, the footrests are adjusted such that at their lowest point they have a height $501 \text{ mm} \pm 2 \text{ mm}$ ($2 \text{ in} \pm 0.08 \text{ in}$) above the platform.

S7.7.2.3 Position the test device with its plane of symmetry coincident with the lift reference plane and at a distance from the platform sufficient to

achieve the impact velocities required by S7.7.2.5.

S7.7.2.4 Accelerate the test device onto the platform under its own power such that the test device impacts the wheelchair retention device at each speed, direction, and load condition combination specified in S7.7.2.5. Maintain power to the drive motors until all wheelchair motion has ceased except rotation of the drive wheels. Cut power to the drive motors. Note the position of the wheelchair after its motion has ceased following each impact to determine compliance with S6.4.7. If necessary, after each impact, adjust or replace the footrests to restore them to their original condition.

S7.7.2.5 The test device is operated at the following speeds, in the following directions—

(a) At a speed of not less than 2.0 m/s (4.4 mph) and not more than 2.1 m/s (4.7 mph), forward, with a load of 0 kg (0 lbs).

(b) At a speed of not less than 1.75 m/s (3.9 mph) and not more than 1.85 m/s (4.1 mph), rearward, with a load of 0 kg (0 lbs).

S7.7.3 *Rotary platform lifts:* For rotary platform lifts, conduct the test under the procedures in S7.7.3.3 through S7.7.3.7 to determine compliance with S6.4.7.2.

S7.7.3.1 *Public use lifts:* For public use lifts, perform the test in both possible test device orientations.

S7.7.3.2 *Private use lifts:* For private use lifts, perform the test in both possible test device orientations unless a required direction of wheelchair movement onto the platform is indicated in the operating instructions. If a required direction is indicated in the operating instructions, perform the test with the test device oriented as required by the operating instructions.

S7.7.3.3 Adjust the footrests of the test device to the shortest length. Place the test device on the platform with its plane of symmetry coincident with the lift reference plane.

S7.7.3.4 Position the platform surface 90 mm \pm 10 mm (3.5 inches \pm 0.4 inches) above the ground level position.

S7.7.3.5 Slowly move the test device in the forward direction until it contacts a wheelchair retention device. Activate the controller of the test device such that, if the test device were unloaded and unrestrained on a flat, level surface, it would achieve a maximum forward velocity of not less than 2.0 m/s (4.4 mph) and not more than 2.1 m/s (4.7 mph).

S7.7.3.6 Realign the test device on the platform so that its plane of symmetry is coincident with the lift

reference plane. Slowly move the test device in the rearward direction until it contacts a wheelchair retention device. Activate the controller of the test device such that, if the test device were unloaded and unrestrained on a flat, level surface, it would achieve a maximum rearward velocity of not less than 1.75 m/s (3.9 mph) and not more than 1.85 m/s (4.1 mph).

S7.7.3.7 During the impacts specified in S7.7.3.5 and S7.7.3.6, maintain power to the drive motors until all test device motion has ceased except rotation of the drive wheels. Note the position of the test device after its motion has ceased following each impact to determine compliance with S6.4.7.2.

S7.8 *Inner roll stop test.* Determine compliance with S6.4.8 using the test device specified in S7.1.2 in accordance with the procedures specified in S7.8.1 through S7.8.6.

S7.8.1 Place the platform at the ground level loading position, such that the platform is level.

S7.8.2 Adjust the footrests of the test device to the shortest length. Position the test device on the ground at a distance from the platform sufficient to achieve the impact velocity required by S7.8.3. The plane of symmetry of the test device is coincident with the lift reference plane and the forward direction of travel is onto the platform.

S7.8.3 Accelerate the test device onto the platform such that it impacts the inner roll stop at a speed of not less than 1.5 m/s (3.4 mph) and not more than 1.6 m/s (3.6 mph). Determine compliance with S6.4.8.3(a).

S7.8.4 If necessary, adjust or replace the footrests to restore them to the condition they were in prior to the impact. Reposition the test device on the platform with its plane of symmetry coincident with the lift reference plane. Slowly move the test device in the forward direction until it contacts the inner roll stop.

S7.8.5 Apply a static load to the inner roll stop by activating the controller of the test device such that, with the test device unrestrained on a flat and level surface, it achieves a maximum forward velocity of not less than 2.0 m/s and not more than 2.1 m/s.

S7.8.6 Maintain control activation and raise the platform to the vehicle loading position. Determine compliance with S6.4.8.3(b).

S7.9 *Static load test I—working load.*

S7.9.1 By use of the lift controls specified in S6.7.2, perform the operations specified in S7.9.2 through S7.9.8 in the order they are specified.

S7.9.2 Place the platform in the stowed position.

S7.9.3 Deploy the platform to the vehicle floor loading position. Center a standard load, including the test pallet, on the platform surface.

S7.9.4 Lower the lift platform from the vehicle floor loading position to the ground level loading position, stopping once between the two positions. Remove the test pallet from the lift platform.

S7.9.5 Raise the lift platform from the ground level loading position to the vehicle floor level loading position, stopping once between the two positions.

S7.9.6 Lower the lift platform from the vehicle floor level loading position to the ground level loading position, stopping once between the two positions.

S7.9.7 Center the loaded test pallet on the platform surface. Raise the lift platform from the ground level loading position to the vehicle floor loading position, stopping once between the two positions.

S7.9.8 Remove the pallet from the lift platform. Stow the lift.

S7.9.9 Turn power off to the lift and repeat S7.9.3 through S7.9.5 and stow the lift using the backup operating mode as specified by S6.9 in accordance with the manufacturer's backup operating instructions.

S7.10 *Fatigue endurance test.*

S7.10.1 Perform the test procedure specified in S7.10.2 through S7.10.6 and determine compliance with S6.5.1.

S7.10.2 Put the unloaded lift platform at the ground level loading position. Center a standard load, including the test pallet, on the platform surface.

S7.10.3 Each sequence of lift operations specified in S7.10.5.1, S7.10.5.2, S7.10.6.1 and S7.10.6.2 are done in blocks of 10 cycles with a 1 minute maximum rest period between each cycle in any block. The minimum rest period between each block of 10 cycles is such that the temperature of the lift components is maintained below the values specified by the manufacturer or that degrade the lift function.

S7.10.4 During the test sequence specified in S7.10.2 through S7.10.6, perform any lift maintenance as specified in the vehicle owner's manual.

S7.10.5 *Public use lifts:* Using the lift controls specified in S6.7.2, perform the operations specified in S7.10.5.1 through S7.10.5.3 in the order they are given.

S7.10.5.1 Raise and lower the platform through the range of passenger operation 3,900 times.

S7.10.5.2 Remove the test pallet from the platform. Raise the platform to the vehicle floor loading position, stow the lift, deploy the lift and lower the platform to the ground level loading position 3,900 times.

S7.10.5.3 Perform the test sequence specified in S7.10.5.1 and S7.10.5.2 two times.

S7.10.6 *Private use lifts:* Using the lift controls specified in S6.7.2, perform the operation specified in S7.10.6.1 through S7.10.6.3 in the order they are given.

S7.10.6.1 Raise and lower the platform through the range of passenger operation 1,100 times.

S7.10.6.2 Remove the test pallet from the platform. Raise the platform to the vehicle floor loading position, stow the lift, deploy the lift and lower the platform to the ground level loading position 1,100 times.

S7.10.6.3 Perform the test sequence specified in S7.10.6.1 and S7.10.6.2 two times.

S7.11 *Static load test II—proof load.*

S7.11.1 Perform the test procedures specified in S7.11.2 through S7.11.5 and determine compliance with S6.5.2.

S7.11.2 Place the platform at the vehicle floor level loading position, center three times the standard load, including the test pallet, on the platform surface. Fully place the pallet on the platform within 1 minute of beginning to place it.

S7.11.3 Two minutes after fully placing the loaded test pallet on the platform surface, remove the loaded test pallet and examine the platform lift and vehicle for separation, fracture or breakage.

S7.11.4 After completing the static load test specified in S7.11.2 through S7.11.4, repeat Static Load Test I specified in S7.9.

S7.12 *Handrail test.*

S7.12.1 To determine compliance with S6.4.9.7, apply 4.4 N (1 lbf) through an area of 1290 mm² (2 in²) in any direction at any point on the handrail in order to remove any looseness or slack from the handrail structure. Use this position of the handrail relative to the platform as the reference point for the measurement of handrail displacement. Apply 445 N

(100 lbf) through an area of 1290 mm² (2 in²) in a direction and location opposite to that of the 4.4 N (1 lbf). Attain the force within 1 minute after beginning to apply it. Five seconds after attaining the force, measure the amount of displacement of the handrail relative to the reference point, and measure the distance between the outside of the handrail and the nearest portion of the vehicle. Release the 445 N (100 lbf) and reapply the 4.4 N (1 lbf) in the direction and location that it was first applied. Five seconds after attaining the force, measure the position of the handrail with respect to the reference point to determine if there is any permanent deformation of the handrail relative to the platform.

S7.12.2 To determine compliance with S6.4.9.8, apply 4.4 N (1 lbf) through an area of 1,290 mm² (2 in²) in any direction at any point on the handrail in order to remove any looseness or slack from the handrail structure. Use this position of the handrail relative to the platform as the reference point for the measurement of handrail displacement. Apply 1,112 N (250 lbf) through an area of 1,290 mm² (2 in²) in a direction and location opposite to that of the 1 4.4 N (1 lbf). Attain the force within 1 minute after beginning to apply it. Five seconds after attaining the force, measure the amount of displacement of the handrail relative to the reference point. Maintain the force for two minutes. Release the force and inspect the handrail for cracking, separations or fractures.

S7.13 *Wheelchair retention device overload test.*

S7.13.1 Perform the test procedures as specified in S7.13.2 through S7.13.5 to determine compliance with S6.4.7.3.

S7.13.2 Position the platform surface 89 mm (3.5 in) above the ground level loading position. Apply 7,117 N (1,600 lbf) to the wheelchair retention device in a direction parallel to both the platform lift and platform reference planes. Attain the force within 1 minute after beginning to apply it.

S7.13.3 For a wheelchair retention device that is in the form of an outer barrier, apply the force through a rectangular area with a height of 25 mm (1 in) and a width spanning the entire

barrier. Distribute the force evenly about an axis 64 mm (2.5 in) above the platform reference plane. If the bottom edge of the outer barrier falls 50 mm (2 in) or more above the platform reference plane, distribute the force about an axis 13 mm (0.5 in) above the bottom edge of the barrier.

S7.13.4 For a wheelchair retention device other than an outer barrier, place the test device specified in S7.1.2 on the lift platform with its plane of symmetry coincident with the lift reference plane and directed such that forward motion is impeded by the wheelchair retention device. Move the test device forward until it contacts the wheelchair retention device. Remove the test device from the platform. Apply the force specified in S7.13.2 distributed evenly at all areas of the wheelchair retention device that made contact with the test device when it was moved forward. Attain the force within 1 minute after beginning to apply it.

S7.13.5 After maintaining the force for two minutes, remove it and examine the wheelchair retention device for separation, fracture or breakage.

S7.14 *Static load test III—ultimate load.*

S7.14.1 Perform the test procedures as specified in S7.14.2 through S7.14.5 to determine compliance with S6.5.3.

S7.14.2 Reinforce the vehicle structure where the lift is attached such that it is rigid and will not deform, break or separate during application of the load specified in S7.14.3 or remove the platform lift from the vehicle and install it on a test jig that is rigid and will not deform, break or separate during application of the load specified in S7.14.3.

S7.14.3 When the platform is at the vehicle floor loading position, center four times the standard load, including the test pallet, on the platform surface. Fully place the pallet on the platform within 1 minute of beginning to place it.

S7.14.4 Two minutes after fully placing the loaded test pallet on the platform surface, remove the loaded test pallet and examine the platform lift for separation, fracture or breakage.

[BILLING CODE]4910-59-P

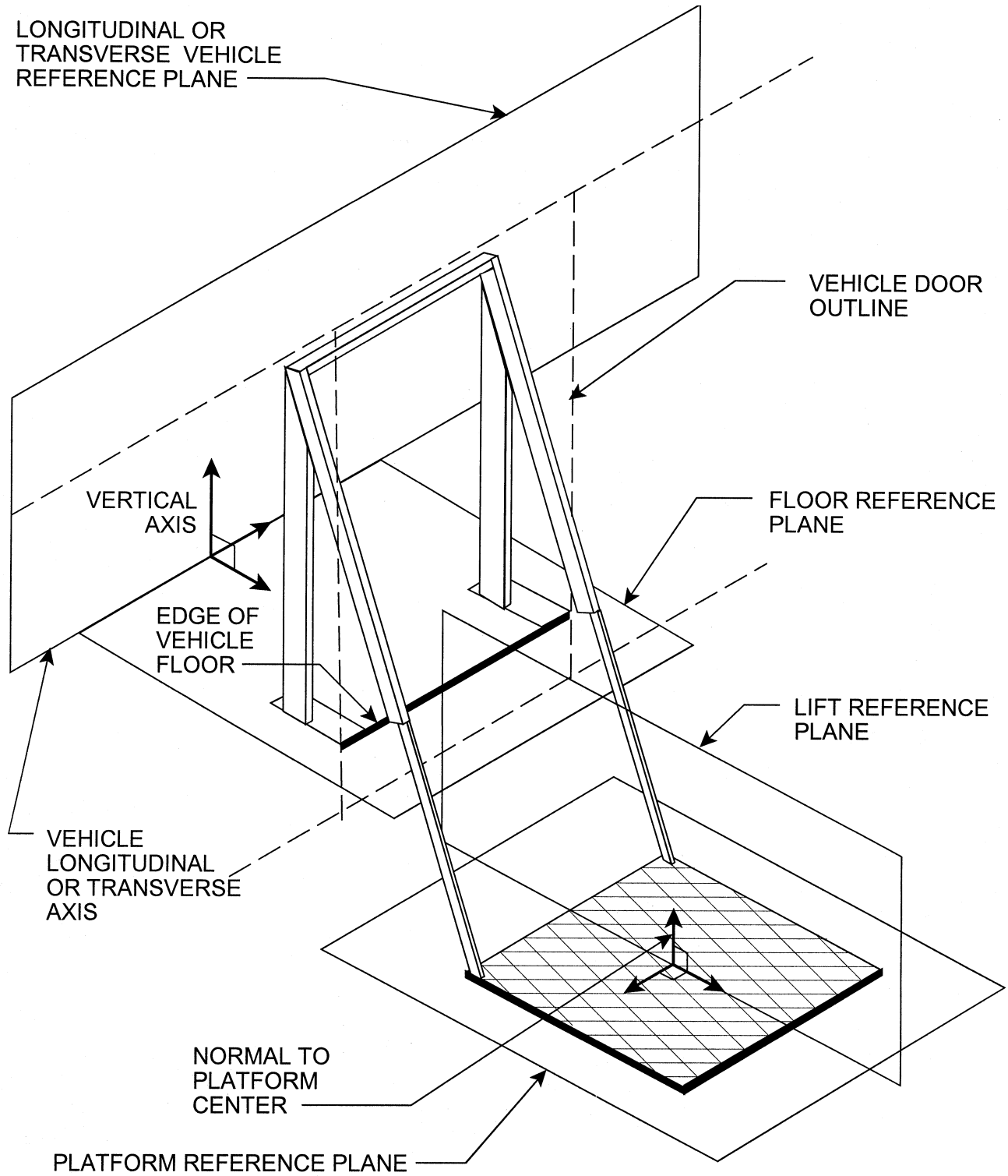

PLANES OF REFERENCE

FIGURE 1

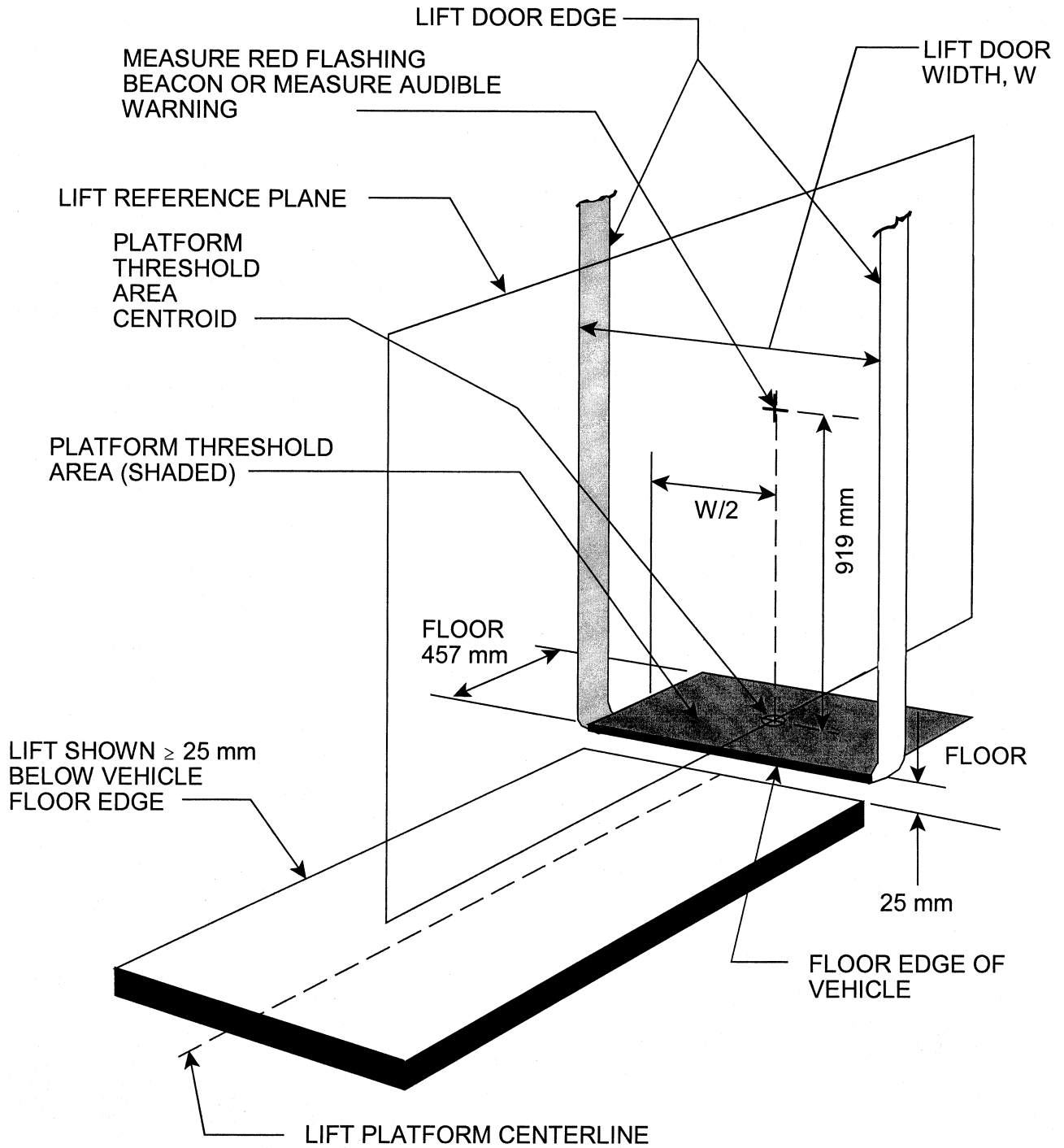

PLATFORM THRESHOLD AREA AUDIBLE WARNING MEASUREMENT POINT

FIGURE 2

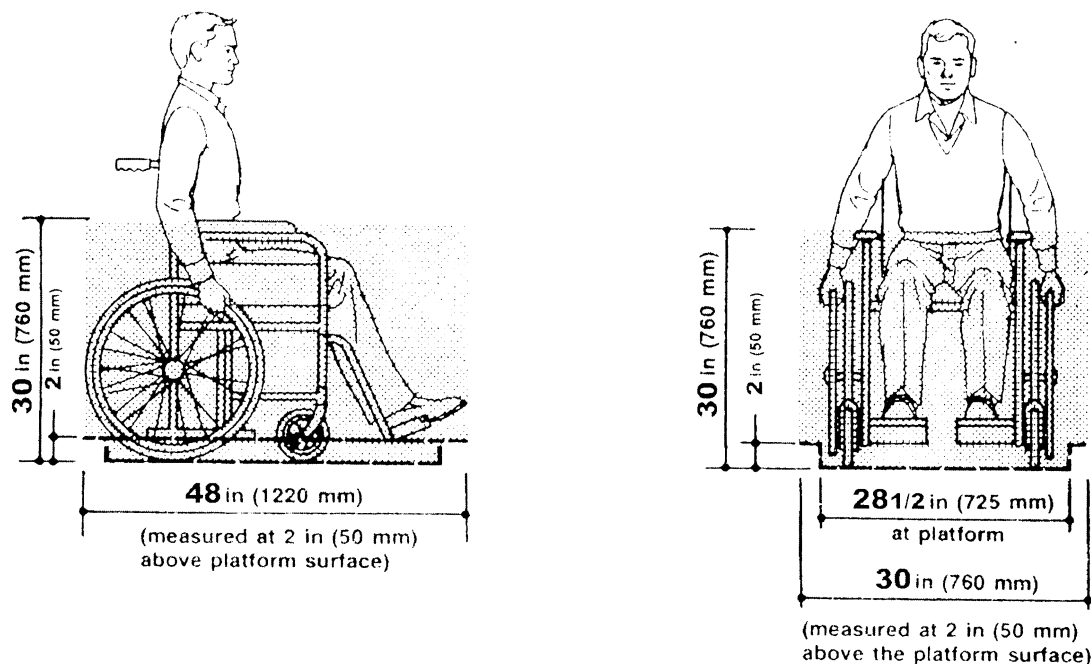

Minimum Unobstructed Platform Operating Volume for Public Use Lifts

Figure 3

BILLING CODE 4910-59-C

8. Section 571.404 is added to read as follows:

§ 571.404 Standard No. 404; Platform lift installations in motor vehicles.

S1. Scope. This standard specifies requirements for vehicles equipped with platform lifts used to assist persons with limited mobility in entering or leaving a vehicle.

S2. Purpose. The purpose of this standard is to prevent injuries and fatalities to passengers and bystanders during the operation of platform lifts installed in motor vehicles.

S3. Application. This standard applies to motor vehicles equipped with a platform lift to carry passengers into and out of the vehicle.

S4. Requirements.

S4.1 Installation requirements.

S4.1.1 Lift-equipped buses, school buses, and MPVs other than motor homes with a GVWR greater than 4,536 kg (10,000 lb) must be equipped with a public use lift certified as meeting Federal Motor Vehicle Safety Standard No. 403, Lift Systems for Motor Vehicles (49 CFR 571.403).

S4.1.2 Lift-equipped motor vehicles, other than ones subject to paragraph S4.1.1, must be equipped with a platform lift certified as meeting either the public use lift or private use lift requirements of Federal Motor Vehicle Safety Standard No. 403, Lift Systems for Motor Vehicles (49 CFR 571.403).

S4.1.3 Platform lifts must be installed in the vehicle in accordance with the installation instructions or procedures provided pursuant to S6.13 of Standard 403. The vehicle must be of a type identified in the installation instructions as appropriate for the platform lift as certified by the platform lift manufacturer.

S4.1.4 The platform lift, as installed, must continue to comply with all the applicable requirements of Federal Motor Vehicle Safety Standard No. 403, Lift Systems for Motor Vehicles (49 CFR 571.403).

S4.2 Vehicle owner's manual insert requirements. If the vehicle is equipped with an owner's manual, the owner's manual must contain the inserts provided by the lift manufacturer pursuant to S6.12 of 49 CFR 571.403.

S4.3 Control system.

S4.3.1 Instructions regarding the platform lift operating procedures, including backup operations, as specified by S6.7.8 of 49 CFR 571.403, must be permanently affixed to a location adjacent to the controls.

S4.3.2 Public use lift: In addition to meeting the requirements of S4.3.1, for vehicles equipped with public use lifts, as defined in 49 CFR 571.403, any and all controls provided for the lift by the platform lift manufacturer other than those provided for back-up operation of the platform lift specified in S5.9 of 49 CFR 571.403, must be located together and in a position such that the control operator has a direct, unobstructed view of the platform lift passenger and/or their mobility aid throughout the lift's range of passenger operation. Additional power controls and controls for back-up operation of the lift may be located in other positions.

Issued on: December 13, 2002.

Jeffrey W. Runge,
Administrator.

[FR Doc. 02-31891 Filed 12-26-02; 8:45 am]

BILLING CODE 4910-59-P