

compliance with this AD, if any, may be obtained from the Regulations Group.

(f) Special flight permits will not be issued.

(g) Installing the placard and inspecting for cracks shall be done in accordance with the Compliance Instructions, Part I and Part III, paragraphs 1 through 6, of Agusta Alert Bollettino Tecnico No. 109EP-30, Revision A, dated July 25, 2002. This incorporation by reference was approved by the Director of the Federal Register in accordance with 5 U.S.C. 552(a) and 1 CFR part 51. Copies may be obtained from Agusta, 21017 Cascina Costa di Samarate (VA) Italy, Via Giovanni Agusta 520, telephone 39 (0331) 229111, fax 39 (0331) 229605-222595. Copies may be inspected at the FAA, Office of the Regional Counsel, Southwest Region, 2601 Meacham Blvd., Room 663, Fort Worth, Texas 76137; or at the Office of the Federal Register, 800 North Capitol Street, NW., suite 700, Washington, DC.

(h) This amendment becomes effective on November 21, 2002, to all persons except those persons to whom it was made immediately effective by Emergency AD 2002-17-51, issued August 19, 2002, which contained the requirements of this amendment.

Note 4: The subject of this AD is addressed in Ente Nazionale per l'Aviazione Civile (Italy) AD No. 2002-384, dated July 29, 2002.

Issued in Fort Worth, Texas, on October 17, 2002.

David A. Downey,

Manager, Rotorcraft Directorate, Aircraft Certification Service.

[FR Doc. 02-27792 Filed 11-5-02; 8:45 am]

BILLING CODE 4910-13-M

DEPARTMENT OF TRANSPORTATION

Federal Aviation Administration

14 CFR Part 39

[Docket No. 2002-SW-38-AD; Amendment 39-12935; AD 2002-22-10]

RIN 2120-AA64

Airworthiness Directives; Bell Helicopter Textron Canada Limited Model 407 Helicopters

AGENCY: Federal Aviation Administration, DOT.

ACTION: Final rule; request for comments.

SUMMARY: This amendment supersedes an existing airworthiness directive (AD) for Bell Helicopter Textron Canada Limited (BHTCL) Model 407 helicopters that requires visually inspecting the brackets that attach the horizontal stabilizer slat (slat) to the stabilizer for a crack. If a crack is found, that AD also requires replacing the slat assembly before further flight. Also, that AD requires installing airworthy, segmented slat assemblies by a specified date.

Installing segmented slat assemblies was considered terminating action for the requirements of that AD. This amendment requires, initially and at certain time intervals, checking each slat assembly for a cracked bracket and, if a crack is found, replacing any unairworthy slat assembly with an improved, airworthy slat assembly. This amendment also requires replacing, modifying, and installing identification plates on slats on certain helicopters at specified time intervals. This amendment is prompted by two additional reports of cracked brackets. The actions specified by this AD are intended to prevent a slat from separating, contacting a rotor blade, and resulting in subsequent loss of control of the helicopter.

DATES: Effective November 21, 2002.

The incorporation by reference of certain publications listed in the regulations is approved by the Director of the Federal Register as of November 21, 2002.

Comments for inclusion in the Rules Docket must be received on or before January 6, 2003.

ADDRESSES: Submit comments in triplicate to the Federal Aviation Administration (FAA), Office of the Regional Counsel, Southwest Region, Attention: Rules Docket No. 2002-SW-38-AD, 2601 Meacham Blvd., Room 663, Fort Worth, Texas 76137. You may also send comments electronically to the Rules Docket at the following address: 9-asw-adcomments@faa.gov.

The service information referenced in this AD may be obtained from Bell Helicopter Textron Canada Limited, 12,800 Rue de l'Avenir, Mirabel, Quebec J7J1R4, telephone (450) 437-2862 or (800) 363-8023, fax (450) 433-0272. This information may be examined at the FAA, Office of the Regional Counsel, Southwest Region, 2601 Meacham Blvd., Room 663, Fort Worth, Texas 76137; or at the Office of the Federal Register, 800 North Capitol Street, NW., suite 700, Washington, DC.

FOR FURTHER INFORMATION CONTACT:

Sharon Miles, Aviation Safety Engineer, FAA, Rotorcraft Directorate, Regulations Group, Fort Worth, Texas 76193-0111, telephone (817) 222-5122, fax (817) 222-5961.

SUPPLEMENTARY INFORMATION: On September 29, 2000, the FAA issued AD 2000-20-18, Amendment 39-11930 (65 FR 62275, October 18, 2000), to require visually inspecting certain slat brackets for a crack and replacing any slat assembly that has a cracked bracket. Also, AD 2000-20-18 required installing a newly designed slat assembly on each affected model before

flight after December 31, 2000. That action was prompted by an incident in which a slat separated from a helicopter. That condition, if not corrected, could result in a slat separating, contacting a rotor blade, and subsequent loss of control of the helicopter.

Since issuing that AD and since installing the newly designed slat assembly, part number (P/N) 407-023-001-101 on affected helicopters, two additional cracked slat brackets have been reported. These occurrences are attributed to a design flaw and improper installation of the slat assembly.

Bell Helicopter Textron has issued Alert Service Bulletin No. 407-02-52, dated March 20, 2002 (ASB). The ASB specifies checking the slats for a crack in the bracket on certain serial-numbered helicopters and replacing the existing slat assembly with a further improved, airworthy, slat assembly on another serial-numbered group of helicopters. The ASB also specifies modifying certain existing slat assemblies for another group of serial-numbered helicopters and installing and marking identification plates after the segmented slat assemblies are installed on certain other helicopters. Transport Canada classified this ASB as mandatory and issued AD CF-2000-09R1, dated June 6, 2002, to ensure the continued airworthiness of these helicopters in Canada.

This helicopter model is manufactured in Canada and is type certificated for operation in the United States under the provisions of 14 CFR 21.29 and the applicable bilateral agreement. Pursuant to the applicable bilateral agreement, Transport Canada has kept the FAA informed of the situation described above. The FAA has examined the findings of Transport Canada, reviewed all available information, and determined that AD action is necessary for products of this type design that are certificated for operation in the United States.

This unsafe condition is likely to exist or develop on other BHTCL Model 407 helicopters of the same type design. Therefore, this AD supersedes AD 2000-20-18 and requires the following:

- Within 10 hours time-in-service (TIS) and thereafter before the first flight of each day:
- For helicopters serial number (S/N) 53000 through 53498 and 53500 through 53503, check each slat for a crack at the radius of each bracket, P/N 206-023-119-109, -110, or 407-023-801-127, -128, or 407-023-011-119, -120, or -121. An owner/pilot (pilot) holding at least a private pilot certificate may perform this check. The pilot must enter compliance with this provision in

accordance with 14 CFR 43.11 and 91.417(a)(2)(v). A pilot may perform this check because it involves only a visual check for a crack in the bracket for the slat and can be performed equally well by a pilot or a mechanic.

- If a crack is found, before further flight, replace slat assembly, P/N 407-023-002-117 or 407-023-001-101 with an airworthy, segmented slat assembly, P/N 407-023-001-103.

- Replacing slat assembly, P/N 407-023-002-117 or 407-023-001-101, with an airworthy, segmented slat assembly, P/N 407-023-001-103, is terminating action for the pilot check.

- Within 300 hours TIS, but not later than December 31, 2002, for helicopters:

- S/N 53000 through 53498, replace slat assembly, P/N 407-023-002-117 and 407-023-001-101, with an airworthy, segmented slat assembly, P/N 407-023-001-103.

- S/N 53500 through 53503, modify each segmented slat assembly, P/N 407-023-001-103.

- S/N 53504 through 53512, install and mark identification plates for each segmented slat assembly, P/N 407-023-001-103.

The actions must be accomplished in accordance with the ASB described previously. The short compliance time involved is required because the previously described critical unsafe condition can adversely affect the structural integrity and controllability of the helicopter. Therefore, checking a certain group of slats for a crack at the radius of each bracket is required before the first flight of each day and must be replaced before December 31, 2002. Thus, this AD must be issued immediately.

Since a situation exists that requires the immediate adoption of this regulation, it is found that notice and opportunity for prior public comment hereon are impracticable, and that good cause exists for making this amendment effective in less than 30 days.

The FAA estimates that this AD will affect 289 helicopters and will require approximately:

- 3.5 work hours to replace the slat assembly for 280 helicopters;
- 3.5 work hours to reinstall the slat assembly for 4 helicopters;
- $\frac{3}{4}$ work hour to install and mark the ID plates for 9 helicopters;
- An average labor rate of \$60 per work hour; and

- \$5,657 for parts per helicopter. The manufacturer states that a 100 percent warranty credit is available for replacing the slat assembly if various conditions are met. Based on these figures, the total cost impact of the AD on U.S. operators is estimated to be \$1,644,005.

Comments Invited

Although this action is in the form of a final rule that involves requirements affecting flight safety and, thus, was not preceded by notice and an opportunity for public comment, comments are invited on this rule. Interested persons are invited to comment on this rule by submitting such written data, views, or arguments as they may desire. Communications should identify the Rules Docket number and be submitted in triplicate to the address specified under the caption **ADDRESSES**. All communications received on or before the closing date for comments will be considered, and this rule may be amended in light of the comments received. Factual information that supports the commenter's ideas and suggestions is extremely helpful in evaluating the effectiveness of the AD action and determining whether additional rulemaking action would be needed.

Comments are specifically invited on the overall regulatory, economic, environmental, and energy aspects of the rule that might suggest a need to modify the rule. All comments submitted will be available in the Rules Docket for examination by interested persons. A report that summarizes each FAA-public contact concerned with the substance of this AD will be filed in the Rules Docket.

Commenters wishing the FAA to acknowledge receipt of their comments submitted in response to this rule must submit a self-addressed, stamped postcard on which the following statement is made: "Comments to Docket No. 2002-SW-38-AD." The postcard will be date stamped and returned to the commenter.

The regulations adopted herein will not have a substantial direct effect on the States, on the relationship between the national Government and the States, or on the distribution of power and responsibilities among the various levels of government. Therefore, it is determined that this final rule does not have federalism implications under Executive Order 13132.

The FAA has determined that this regulation is an emergency regulation that must be issued immediately to correct an unsafe condition in aircraft, and that it is not a "significant regulatory action" under Executive Order 12866. It has been determined further that this action involves an emergency regulation under DOT Regulatory Policies and Procedures (44 FR 11034, February 26, 1979). If it is determined that this emergency regulation otherwise would be

significant under DOT Regulatory Policies and Procedures, a final regulatory evaluation will be prepared and placed in the Rules Docket. A copy of it, if filed, may be obtained from the Rules Docket at the location provided under the caption **ADDRESSES**.

List of Subjects in 14 CFR Part 39

Air transportation, Aircraft, Aviation safety, Incorporation by reference, Safety.

Adoption of the Amendment

Accordingly, pursuant to the authority delegated to me by the Administrator, the Federal Aviation Administration amends part 39 of the Federal Aviation Regulations (14 CFR part 39) as follows:

PART 39—AIRWORTHINESS DIRECTIVES

1. The authority citation for part 39 continues to read as follows:

Authority: 49 U.S.C. 106(g), 40113, 44701.

§ 39.13 [Amended]

2. Section 39.13 is amended by removing Amendment 39-11930 (65 FR 62275, October 18, 2000), and by adding a new airworthiness directive (AD), Amendment 39-12935, to read as follows:

2002-22-10 Bell Helicopter Textron

Canada Limited: Amendment 39-12935. Docket No. 2002-SW-38-AD. Supersedes AD 2000-20-18, Amendment 39-11930, Docket No. 2000-SW-24-AD.

Applicability: Model 407 helicopters, serial number (S/N) 53000 through 53498 and 53500 through 53512, certificated in any category.

Note 1: This AD applies to each helicopter identified in the preceding applicability provision, regardless of whether it has been otherwise modified, altered, or repaired in the area subject to the requirements of this AD. For helicopters that have been modified, altered, or repaired so that the performance of the requirements of this AD is affected, the owner/operator must request approval for an alternative method of compliance in accordance with paragraph (c) of this AD. The request should include an assessment of the effect of the modification, alteration, or repair on the unsafe condition addressed by this AD; and if the unsafe condition has not been eliminated, the request should include specific proposed actions to address it.

Compliance: Required as indicated, unless accomplished previously.

To prevent the horizontal stabilizer slat (slat) from separating, contacting a rotor blade, and resulting in subsequent loss of control of the helicopter, accomplish the following:

(a) For helicopters, S/N 53000 through 53498 and 53500 through 53503:

(1) Within 10 hours time-in-service (TIS) and thereafter before the first flight of each day, check each slat for a crack at the radius

of each bracket, part numbers (P/N) 206-023-119-109, -110 or 407-023-801-127, -128, or

407-023-001-119, -120, or -121, as shown in Figure 1 of this AD:

BILLING CODE 4910-13-P

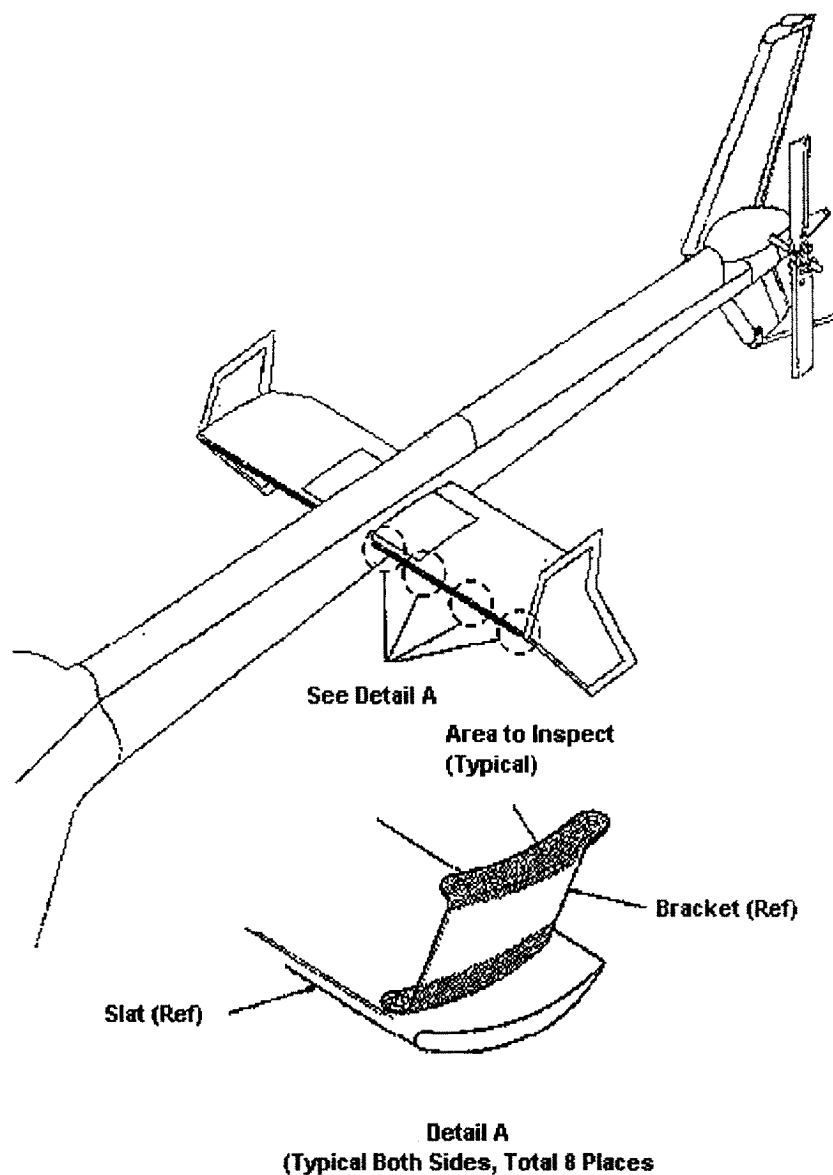

Figure 1. Pre-Flight check of brackets, horizontal stabilizer slats.

BILLING CODE 4910-13-C

(2) An owner/operator (pilot) holding at least a private pilot certificate may perform the check required by paragraph (a)(1) of this AD. The pilot must enter compliance with this provision in accordance with 14 CFR 43.11 and 91.417(a)(2)(v).

(3) If a crack is found, before further flight, replace slat assembly, P/N 407-023-002-117 or 407-023-001-101, with an airworthy, segmented slat assembly, P/N 407-023-001-103.

(4) Replacing slat assembly, P/N 407-023-002-117 and 407-023-001-101, with an

airworthy, segmented slat assembly, P/N 407-023-001-103, is terminating action for the check required by paragraph (a)(1) of this AD.

(b) Within 300 hours TIS but no later than December 31, 2002:

(1) For helicopters, S/N 53000 through 53498, replace slat assembly, P/N 407-023-002-117 and 407-023-001-101, with an airworthy, segmented slat assembly, P/N 407-023-001-103, in accordance with the Accomplishment Instructions, Part II, Bell Helicopter Textron Alert Service Bulletin 407-02-52, dated March 20, 2002 (ASB).

(2) For helicopters, S/N 53500 through 53503, modify each segmented slat assembly in accordance with the Accomplishment Instructions, Part III, of the ASB.

(3) For helicopters, S/N 53504 through 53512, install and mark identification plates for each slat assembly in accordance with the Accomplishment Instructions, Part IV, of the ASB.

(c) An alternative method of compliance or adjustment of the compliance time that provides an acceptable level of safety may be used if approved by the Manager, Regulations Group, Rotorcraft Directorate, FAA.

Operators shall submit their requests through an FAA Principal Maintenance Inspector, who may concur or comment and then send it to the Manager, Regulations Group.

Note 2: Information concerning the existence of approved alternative methods of compliance with this AD, if any, may be obtained from the Regulations Group.

(d) Special flight permits may be issued in accordance with 14 CFR 21.197 and 21.199 to operate the helicopter to a location where the requirements of this AD can be accomplished.

(e) Replacing and modifying the slats and installing and marking the identification plates shall be done in accordance with the Accomplishment Instructions, Part II, Part III, and Part IV, respectively, of Bell Helicopter Textron Alert Service Bulletin 407-02-52, dated March 20, 2002. This incorporation by reference was approved by the Director of the Federal Register in accordance with 5 U.S.C. 552(a) and 1 CFR part 51. Copies may be obtained from Bell Helicopter Textron Canada Limited, 12,800 Rue de l'Avenir, Mirabel, Quebec J7J1R4, telephone (450) 437-2862 or (800) 363-8023, fax (450) 433-0272. Copies may be inspected at the FAA, Office of the Regional Counsel, Southwest Region, 2601 Meacham Blvd., Room 663, Fort Worth, Texas; or at the Office of the Federal Register, 800 North Capitol Street, NW., suite 700, Washington, DC.

(f) This amendment becomes effective on November 21, 2002.

Note 3: The subject of this AD is addressed in Transport Canada (Canada) AD CF-2000-09R1, dated June 6, 2002.

Issued in Fort Worth, Texas, on October 21, 2002.

Eric D. Bries,

*Acting Manager, Rotorcraft Directorate,
Aircraft Certification Service.*

[FR Doc. 02-27791 Filed 11-5-02; 8:45 am]

BILLING CODE 4910-13-P

DEPARTMENT OF TRANSPORTATION

Federal Aviation Administration

14 CFR Part 39

[Docket No. 2002-SW-36-AD; Amendment 39-12934; AD 2002-22-09]

RIN 2120-AA64

Airworthiness Directives; Eurocopter France Model AS332C, L, and L1 Helicopters

AGENCY: Federal Aviation Administration, DOT.

ACTION: Final rule; request for comments.

SUMMARY: This amendment adopts a new airworthiness directive (AD) for the specified Eurocopter France (ECF) model helicopters. This action requires, before further flight, inserting statements into the Limitations section

of the Rotorcraft Flight Manual (RFM) prohibiting flight under certain atmospheric conditions. Also, this AD requires inspecting the bullet seal on the multi-purpose air intake (MPAI) to determine the pressure and, if the pressure is less than 3 bars on one or both of the sides, replacing the P2 pipe with an airworthy P2 pipe within a specified time interval. This amendment is prompted by the discovery of unairworthy P2 pipes, which might cause insufficient inflation of the bullet seal on the MPAI. This condition, if not detected, could restrict airflow into the engine inlet during flight in icing conditions, resulting in loss of engine power and subsequent loss of control of the helicopter.

DATES: Effective November 21, 2002.

The incorporation by reference of certain publications listed in the regulations is approved by the Director of the Federal Register as of November 21, 2002.

Comments for inclusion in the Rules Docket must be received on or before January 6, 2003.

ADDRESSES: Submit comments in triplicate to the Federal Aviation Administration (FAA), Office of the Regional Counsel, Southwest Region, Attention: Rules Docket No. 2002-SW-36-AD, 2601 Meacham Blvd., Room 663, Fort Worth, Texas 76137. You may also send comments electronically to the Rules Docket at the following address: 9-asw-adcomments@faa.gov.

The service information referenced in this AD may be obtained from American Eurocopter Corporation, 2701 Forum Drive, Grand Prairie, Texas 75053-4005, telephone (972) 641-3460, fax (972) 641-3527. This information may be examined at the FAA, Office of the Regional Counsel, Southwest Region, 2601 Meacham Blvd., Room 663, Fort Worth, Texas; or at the Office of the Federal Register, 800 North Capitol Street, NW., suite 700, Washington, DC.

FOR FURTHER INFORMATION CONTACT: Ed Cuevas, Aviation Safety Engineer, FAA, Rotorcraft Directorate, Regulations Group, Fort Worth, Texas 76193-0111, telephone (817) 222-5355, fax (817) 222-5961.

SUPPLEMENTARY INFORMATION: The Direction Generale De L'Aviation Civile (DGAC), the airworthiness authority for France, notified the FAA that an unsafe condition may exist on the specified helicopter models. The DGAC advises of the discovery of noncompliant P2 pipes, which might cause insufficient inflation of the bullet seal and lead to engine flame-out during flight in icing condition.

Eurocopter has issued Alert Telex No. 30.00.52 R1, dated April 10, 2002 (Telex), which adds limitations for flight into icing conditions, provides procedures for checking the bullet seal, and specifies replacing any P2 pipe if the pressure on the pressure gage is below 3 bars on one or on both sides. The DGAC classified this Telex as mandatory and issued AD No. 2002-257-080(A), dated May 15, 2002, to ensure the continued airworthiness of these helicopters in France.

These helicopter models are manufactured in France and are type certificated for operation in the United States under the provisions of 14 CFR 21.29 and the applicable bilateral agreement. Pursuant to the applicable bilateral agreement, the DGAC has kept the FAA informed of the situation described above. The FAA has examined the findings of the DGAC, reviewed all available information, and determined that AD action is necessary for products of these type designs that are certificated for operation in the United States.

This unsafe condition is likely to exist or develop on other helicopters of these same type designs registered in the United States. Therefore, this AD is being issued to prevent restricted airflow into the engine inlet during flight in certain atmospheric conditions conducive to icing that could result in loss of complete engine power and subsequent loss of control of the helicopter. This AD requires, before further flight, inserting statements into the Limitations section of the RFM prohibiting flight under certain atmospheric conditions. Also, this AD requires within 10 hours time-in-service (TIS), inspecting the bullet seal on the MPAI to determine the pressure. If the pressure is less than 3 bars on either side, this AD requires, within 100 hours TIS, replacing each unairworthy P2 pipe with an airworthy P2 pipe, which is terminating action for the requirements of this AD. The actions must be done in accordance with the Telex described previously.

None of the Model AS332C, L, or L1 helicopters currently on the U.S. Register have the MPAI installed. All helicopters that have the MPAI installed, included in the applicability of this rule, are currently operated by non-U.S. operators under foreign registry; therefore, they are not directly affected by this AD action. However, the FAA considers that this rule is necessary to ensure that the unsafe condition is addressed in the event that any of these subject helicopters have the MPAI installed in the future.