

# Proposed Rules

Federal Register

Vol. 67, No. 185

Tuesday, September 24, 2002

This section of the FEDERAL REGISTER contains notices to the public of the proposed issuance of rules and regulations. The purpose of these notices is to give interested persons an opportunity to participate in the rule making prior to the adoption of the final rules.

## NUCLEAR REGULATORY COMMISSION

### 10 CFR Part 35

[Docket No. PRM-35-13]

#### National Registry of Radiation Protection Technologists; Withdrawal of Petition for Rulemaking

**AGENCY:** Nuclear Regulatory Commission.

**ACTION:** Withdrawal of petition for rulemaking.

**SUMMARY:** The Nuclear Regulatory Commission (NRC) is notifying the public of the withdrawal of a petition for rulemaking (PRM-35-13) submitted by the National Registry of Radiation Protection Technologists (NRRPT). The petitioner requested that the NRC amend its regulations to accept NRRPT registration in lieu of the requirement for 200 hours of classroom training specified in 10 CFR 35.900(b)(1), and to accept the NRRPT registration as a substitute for 9 of the 12 months experience required in 10 CFR 35.900(b)(2) as a radiation safety technologist at a medical institution under the supervision of the Radiation Safety Officer (RSO). Since the receipt of the petition, the NRC has revised 10 CFR part 35, essentially in its entirety. The final rule was published in the **Federal Register** on April 24, 2002 (67 FR 20251-20397). On August 7, 2002, the petitioner formally withdrew its petition.

**ADDRESSES:** Copies of the petition for rulemaking, the public comments received, and NRC's e-mail acknowledging the petitioner's request to withdraw the petition may be examined at the NRC Public Document Room, Room O1F23, 11555 Rockville Pike, Rockville, MD. These documents also may be viewed and downloaded electronically via the rulemaking Web site.

The NRC maintains an Agencywide Document Access and Management System (ADAMS), which provides text

and image files of NRC's public documents. These documents may be accessed through the NRC's Public Electronic Reading Room on the Internet at <http://www.nrc.gov/reading-rm/adams.html>. If you do not have access to ADAMS or if there are problems in accessing the documents located in ADAMS, contact the NRC Public Document Room (PDR) Reference staff at 1-800-397-4209, 301-415-4737, or by e-mail to [pdr@nrc.gov](mailto:pdr@nrc.gov).

#### FOR FURTHER INFORMATION CONTACT:

Patricia L. Eng, Office of Nuclear Material Safety and Safeguards, U.S. Nuclear Regulatory Commission, Washington, DC 20555-0001, telephone (301) 415-7206, e-mail [ple@nrc.gov](mailto:ple@nrc.gov).

**SUPPLEMENTARY INFORMATION:** On February 8, 1996, (61 FR 4754), the NRC published a notice of receipt of a petition for rulemaking PRM 35-13 in the **Federal Register**. The petition was submitted by the National Registry of Radiation Protection Technologists. The petition requested that the NRC amend its regulations to accept NRRPT registration in lieu of the requirement for 200 hours of classroom training specified in 10 CFR 35.900(b)(1), and to accept the NRRPT registration as a substitute for 9 of the 12 months experience required in 10 CFR 35.900(b)(2) as a radiation safety technologist at a medical institution under the supervision of the Radiation Safety Officer. Since the receipt of the petition, the NRC has revised 10 CFR part 35, essentially in its entirety. The final rule was published in the **Federal Register** on April 24, 2002 (67 FR 20251-20397). On August 7, 2002, the petitioner informed the NRC that it wished to withdraw its petition. Based on the petitioner's request, the NRC is withdrawing this petition for rulemaking.

Dated at Rockville, Maryland, this 18th day of September 2002.

For the Nuclear Regulatory Commission.

**Annette Vietti-Cook,**

*Secretary of the Commission.*

[FR Doc. 02-24221 Filed 9-23-02; 8:45 am]

**BILLING CODE 7590-01-P**

## DEPARTMENT OF TRANSPORTATION

### Federal Aviation Administration

#### 14 CFR Part 39

[Docket No. 2001-SW-40-AD]

RIN 2120-AA64

#### Airworthiness Directives; MD Helicopters, Inc. Model 369D, 369E, 369F, and 369FF Helicopters

**AGENCY:** Federal Aviation Administration, DOT.

**ACTION:** Notice of proposed rulemaking (NPRM).

**SUMMARY:** This document proposes to revise an existing airworthiness directive (AD) for the specified MD Helicopters, Inc. (MDHI) helicopters. That AD currently requires identifying the part number (P/N) of the bolts that attach the tail rotor gearbox to the tailboom and replacing any bolt of inadequate grip length with an airworthy bolt. That AD also requires adding an additional washer if more than four threads protrude from the nutplate. This action would contain the same requirements as the existing AD but would reduce the applicability to only certain tailboom serial numbers and parts modified in accordance with either Supplemental Type Certificate (STC) SH5055NM or SH4801NM. The action would also correct a typographical error and clarify that a slippage mark needs to be reapplied to each bolt regardless of the outcome of the required torque test. This proposal is prompted by the need to reduce the applicability and to correct and clarify other portions of the existing AD. The actions specified by the proposed AD are intended to prevent loss of a tail rotor gearbox due to bolts of inadequate grip length and subsequent loss of control of the helicopter.

**DATES:** Comments must be received by November 25, 2002.

**ADDRESSES:** Submit comments in triplicate to the Federal Aviation Administration (FAA), Office of the Regional Counsel, Southwest Region, Attention: Rules Docket No. 2001-SW-40-AD, 2601 Meacham Blvd., Room 663, Fort Worth, Texas 76137. You may also send comments electronically to the Rules Docket at the following address: [9-asw-adcomments@faa.gov](mailto:9-asw-adcomments@faa.gov). Comments may be inspected at the

Office of the Regional Counsel between 9 a.m. and 3 p.m., Monday through Friday, except Federal holidays.

**FOR FURTHER INFORMATION CONTACT:** John Cecil, Aviation Safety Engineer, FAA, Los Angeles Aircraft Certification Office, Airframe Branch, 3960 Paramount Blvd., Lakewood, California 90712-4137, telephone (562) 627-5228, fax (562) 627-5210.

**SUPPLEMENTARY INFORMATION:**

**Comments Invited**

Interested persons are invited to participate in the making of the proposed rule by submitting such written data, views, or arguments as they may desire. Communications should identify the Rules Docket number and be submitted in triplicate to the address specified above. All communications received on or before the closing date for comments, specified above, will be considered before taking action on the proposed rule. The proposals contained in this document may be changed in light of the comments received.

Comments are specifically invited on the overall regulatory, economic, environmental, and energy aspects of the proposed rule. All comments submitted will be available, both before and after the closing date for comments, in the Rules Docket for examination by interested persons. A report summarizing each FAA-public contact concerned with the substance of this proposal will be filed in the Rules Docket.

Commenters wishing the FAA to acknowledge receipt of their mailed comments submitted in response to this proposal must submit a self-addressed, stamped postcard on which the following statement is made: "Comments to Docket No. 2001-SW-40-AD." The postcard will be date stamped and returned to the commenter.

**Discussion**

On June 18, 2002, the FAA issued AD 2002-13-05, Amendment 39-12793 (67 FR 43227, June 27, 2002), for specified MDHI model helicopters with a tailboom modified according to either Aerometals STC SH5055NM or SH4801NM. These STC's were formerly owned by Yehmert Helicopters, Inc. That action was prompted by the discovery that the maintenance instructions

supplied to installers of STC SH5055NM and SH4801NM incorrectly specified the tail rotor gearbox attaching bolt as S/B NAS 1304-25, which has an inadequate grip length. That condition, if not corrected, could result in loss of a tail rotor gearbox and subsequent loss of control of the helicopter.

Before its issuance, the FAA solicited comments to the proposed AD by a Notice of Proposed Rulemaking that was published in the **Federal Register** on December 27, 2001 (66 FR 66821). One commenter stated that the applicability of the AD should be limited to certain part-numbered tailbooms with serial number (S/N) 5001-5032 specified in the FAA-approved Aerometals Service Bulletin. We did not agree with the commenter and, except for minor editorial changes, issued the AD as it had been proposed.

Since the issuance of AD 2002-13-05, the FAA has determined that we inappropriately responded to the comment and that the commenter's concern was valid. We are now proposing to reduce the applicability of AD 2002-13-05 to include only certain tailboom serial numbers and parts that are modified in accordance with either STC SH5055NM or SH4801NM. We have also found that the P/N for washer, P/N AN960D416, was incorrect where referenced in Figure 1 and that clarification that a slippage mark needs to be reapplied to each bolt regardless of the outcome of the required torque test is necessary.

The unsafe condition described previously is likely to exist or develop on other helicopters of these same type designs. Therefore, the actions required by AD 2002-13-05 will remain the same, but this proposed AD would reduce the applicability of AD 2002-13-05, correct the P/N for the washer, and clarify that a slippage mark must be reapplied to each bolt regardless of the outcome of the required torque test.

The FAA estimates that this proposed AD would affect 500 helicopters of U.S. registry. It would take approximately 1/2 work hour per helicopter to determine whether a helicopter has been modified by either STC and 1 work hour to inspect and replace the bolts for each of approximately 40 helicopters modified by the STC's. The average labor rate is \$60 per work hour. Required parts would cost approximately \$40 per helicopter. Based on these figures, the total cost impact of the proposed AD on

U.S. operators is estimated to be \$19,000.

The regulations proposed herein would not have a substantial direct effect on the States, on the relationship between the national Government and the States, or on the distribution of power and responsibilities among the various levels of government. Therefore, it is determined that this proposal would not have federalism implications under Executive Order 13132.

For the reasons discussed above, I certify that this proposed regulation (1) is not a "significant regulatory action" under Executive Order 12866; (2) is not a "significant rule" under the DOT Regulatory Policies and Procedures (44 FR 11034, February 26, 1979); and (3) if promulgated, will not have a significant economic impact, positive or negative, on a substantial number of small entities under the criteria of the Regulatory Flexibility Act. A copy of the draft regulatory evaluation prepared for this action is contained in the Rules Docket. A copy of it may be obtained by contacting the Rules Docket at the location provided under the caption

**ADDRESSES.**

**List of Subjects in 14 CFR Part 39**

Air transportation, Aircraft, Aviation safety, Safety.

**The Proposed Amendment**

Accordingly, pursuant to the authority delegated to me by the Administrator, the Federal Aviation Administration proposes to amend part 39 of the Federal Aviation Regulations (14 CFR part 39) as follows:

**PART 39—AIRWORTHINESS DIRECTIVES**

1. The authority citation for part 39 continues to read as follows:

**Authority:** 49 U.S.C. 106(g), 40113, 44701.

**§ 39.13 [Amended]**

2. Section 39.13 is amended by removing Amendment 39-12793 (67 FR 43227, June 27, 2002), and by adding a new airworthiness directive (AD), to read as follows:

**MD Helicopters, Inc.:** Docket No. 2001-SW-40-AD. Revises AD 2002-13-05, Amendment 39-12793.

*Applicability:* The following MD Helicopters, Inc. helicopter models, certificated in any category:

| Helicopter model                  | With  | Modified in accordance with                              |
|-----------------------------------|---|--|
| (1) 369D, 369E, 369F, 369FF ..... | Tailboom, serial number (S/N) 5001-5032 ..... | Aerometals Supplemental Type Certificate (STC) SH5055NM. |
| (2) 369D and 369E .....           | Tail Rotor Gearbox Attach Bolts .....         | Aerometals STC SH4801NM.                                 |

**Note 1:** This AD applies to each helicopter identified in the preceding applicability provision, regardless of whether it has been otherwise modified, altered, or repaired in the area subject to the requirements of this AD. For helicopters that have been modified, altered, or repaired so that the performance of the requirements of this AD is affected, the owner/operator must request approval for an alternative method of compliance in accordance with paragraph (c) of this AD. The request should include an assessment of the effect of the modification, alteration, or repair on the unsafe condition addressed by this AD; and if the unsafe condition has not

been eliminated, the request should include specific proposed actions to address it.

**Compliance:** Required as indicated, unless accomplished previously.

To prevent loss of the tail rotor gearbox due to attaching bolts of inadequate grip length and subsequent loss of control of the helicopter, accomplish the following:

- (a) Within 25 hours time-in-service (TIS):
- (1) For each tail rotor gearbox attaching bolt (bolt):
    - (i) Determine the part number (P/N).
    - (ii) If the P/N cannot be determined or if the bolt is not P/N NAS1304-26, before further flight, replace the bolt with bolt, P/N NAS1304-26.

(iii) Torque the bolt to 100-110 in-lbs and apply a slippage mark.

(2) Remove the tailboom control rod and determine the number of bolt threads protruding from each nutplate on the internal surface of the aft tailboom frame casting, P/N 369D23503, as shown in Figure 1 of this AD. At least one thread must protrude. If more than four threads protrude, add an additional washer, P/N AN960D416, under the bolt head. Torque the bolt to 100-110 in-lbs, and reapply a slippage mark. See Figure 1:

**BILLING CODE 4910-13-P**

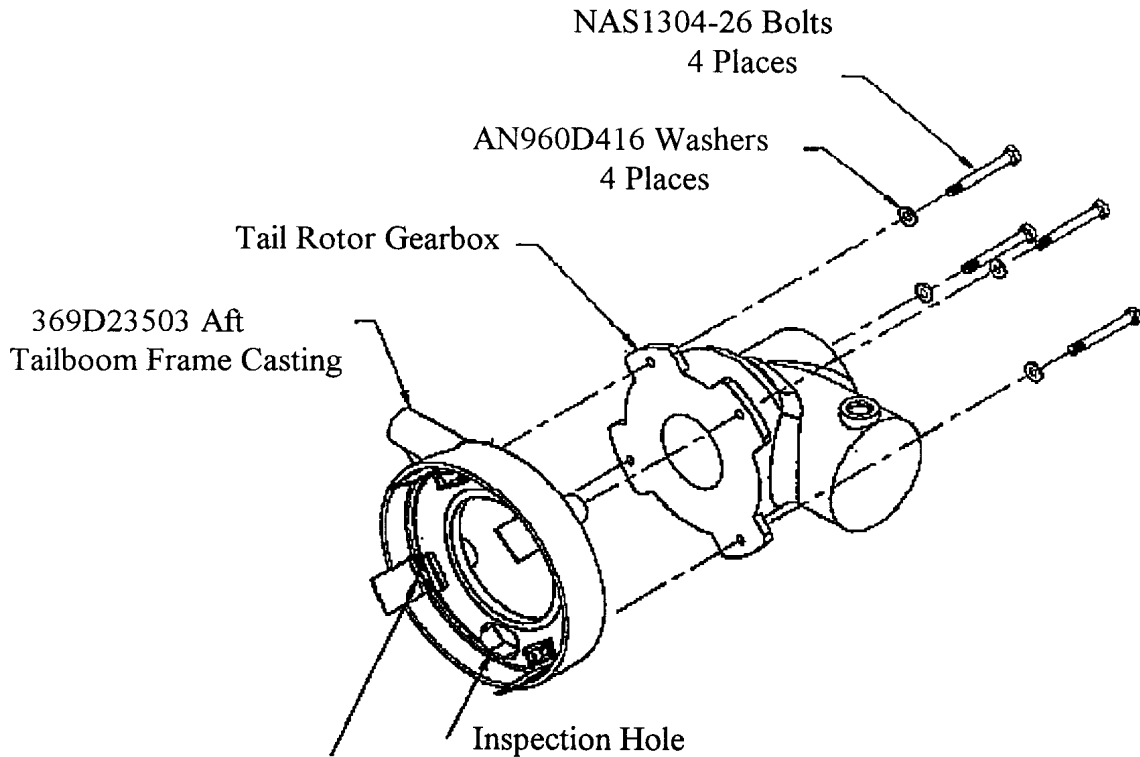

Inspect this area of each bolt.  
Bolt must protrude at least one thread past end of nutplate 4 places.

**Figure 1 - Inspection Location**

(b) Between 2 and 10 hours TIS after accomplishing the requirements of paragraph (a) of this AD, inspect the torque on each bolt by applying 100 in-lbs. If any bolt movement occurs, retorque the bolt to 100–110 in-lbs. Reapply a slippage mark to the bolt regardless of the outcome of the torque test. Reinspect the torque between 2 and 10 hours TIS thereafter until no bolt movement occurs.

**Note 2:** Aerometals Service Bulletin SB-001, dated August 3, 2000, pertains to the subject of this AD.

(c) An alternative method of compliance or adjustment of the compliance time that provides an acceptable level of safety may be used if approved by the Manager, Los Angeles Aircraft Certification Office (LAACO), FAA. Operators shall submit their requests through an FAA Principal Maintenance Inspector, who may concur or comment and then send it to the Manager, LAACO.

**Note 3:** Information concerning the existence of approved alternative methods of compliance with this AD, if any, may be obtained from the LAACO.

(d) Special flight permits will not be issued.

Issued in Fort Worth, Texas, on September 13, 2002.

**Eric D. Bries,**

*Acting Manager, Rotorcraft Directorate,  
Aircraft Certification Service.*

[FR Doc. 02-24182 Filed 9-23-02; 8:45 am]

**BILLING CODE 4910-13-P**

## DEPARTMENT OF LABOR

### Employment and Training Administration

#### 20 CFR Part 655

RIN 1205-AB24

#### Labor Certification and Petition Process for the Temporary Employment of Nonimmigrant Aliens in Agriculture in the United States; Modification of Fee Structure; Withdrawal of Proposed Rule

**AGENCY:** Employment and Training Administration, Labor.

**ACTION:** Withdrawal of proposed rule.

**SUMMARY:** The Department of Labor is withdrawing its proposed rule published in the **Federal Register** on July 13, 2001 (65 FR 43545), which would have required employers seeking to temporarily employ nonimmigrant farmworkers to submit, at the time of filing, a new consolidated application form, fees for the labor certification, and the associated H-2A petition. For the reasons discussed below, the Department has decided to withdraw

the proposed rule and to terminate the rulemaking.

**DATES:** This withdrawal is made on September 24, 2002.

**FOR FURTHER INFORMATION CONTACT:** Charlene G. Giles, Team Leader, Division of Foreign Labor Certification, Employment and Training Administration, U.S. Department of Labor, Room C-4318, 200 Constitution Avenue, NW., Washington, DC 20210. Telephone (202) 693-2950 (this is not toll-free number).

**SUPPLEMENTARY INFORMATION:** The Department is withdrawing a proposed rule related to the temporary employment of nonimmigrant agriculture (H-2A) workers in the United States. The proposed amendment would have required an employer seeking a temporary alien agricultural labor certification to submit with a consolidated application form the fees for labor certification and the associated H-2A petition. The proposal also would have modified the fee structure for issuing H-2A labor certifications. Agricultural employers and workers and their representatives strongly opposed DOL's proposal to consolidate into a proposed new Form 9079 the existing two forms (Form ETA 750 and Form I-129) used by DOL for the certification process and by the Immigration and Naturalization Service (INS) for the H-2A visa petition process. Both groups of commenters cited increased difficulties with the new form, such as the requirement that the employer obtain the foreign agricultural worker's signature and the requirement to accurately state the terms and conditions of employment of complex agricultural occupations.

The proposed rule also would have established a three-tiered labor certification fee based upon the number of temporary workers for which each agricultural employer was applying. Agricultural employers commented that the proposed three-tiered fee structure would be unfavorable to small farmers, and they recommended that no such change be made.

Based upon the Department's review of the rulemaking record as a whole, the Department has decided to withdraw the proposed rule and terminate the rulemaking action.

Signed at Washington DC, this 18th day of September, 2002.

**Emily Stover DeRocco,**

*Assistant Secretary of Labor for Employment and Training.*

[FR Doc. 02-24190 Filed 9-23-02; 8:45 am]

**BILLING CODE 4510-30-P**

## DEPARTMENT OF THE TREASURY

### Internal Revenue Service

#### 26 CFR Part 1

[REG-126024-01]

RIN 1545-AW72

#### Reporting of Gross Proceeds Payments to Attorneys; Hearing Cancellation

**AGENCY:** Internal Revenue Service (IRS), Treasury.

**ACTION:** Cancellation of notice of public hearing on proposed rulemaking.

**SUMMARY:** This document provides notice of cancellation of a public hearing on proposed regulations under sections 6041 and 6045 of the Internal Revenue Code.

**DATES:** The public hearing originally scheduled for September 30, 2002, at 10 a.m., is cancelled.

**FOR FURTHER INFORMATION CONTACT:** Treena Garrett of the Regulations Unit, Associate Chief Counsel (Income Tax and Accounting), (202) 622-7180 (not a toll-free number).

**SUPPLEMENTARY INFORMATION:** A notice of proposed rulemaking and notice of public hearing that appeared in the **Federal Register** on May 17, 2002, (67 FR 35064), announced that a public hearing was scheduled for September 30, 2002, at 10 a.m., Internal Revenue Service Building, 1111 Constitution Avenue, NW, Washington, DC. The subject of the public hearing is proposed regulations under sections 6041 and 6045 of the Internal Revenue Code. The public comment period for these proposed regulations expired on August 15, 2002.

The notice of proposed rulemaking and notice of public hearing, instructed those interested in testifying at the public hearing to submit a request to speak and an outline of the topics to be addressed. As of September 18, 2002, no one has requested to speak. Therefore, the public hearing scheduled for September 30, 2002, is cancelled.

**Cynthia E. Grigsby,**

*Chief, Regulations Unit, Associate Chief Counsel (Income Tax and Accounting).*

[FR Doc. 02-24249 Filed 9-23-02; 8:45 am]

**BILLING CODE 4830-01-P**