

states that a Part 543 exemption applies only to vehicles that belong to a line exempted under this part and equipped with the antitheft device on which the line's exemption is based. Further, § 543.9(c)(2) provides for the submission of petitions to modify an exemption to permit the use of an antitheft device similar to but differing from the one specified in that exemption."

The agency wishes to minimize the administrative burden that § 543.9(c)(2) could place on exempted vehicle manufacturers and itself. The agency did not intend in drafting Part 543 to require the submission of a modification petition for every change to the components or design of an antitheft device. The significance of many such changes could be *de minimis*. Therefore, NHTSA suggests that if the manufacturer contemplates making any changes the effects of which might be characterized as *de minimis*, it should consult the agency before preparing and submitting a petition to modify.

Authority: 49 U.S.C. 33106; delegation of authority at 49 CFR 1.50.

Issued on: June 26, 2002.

Stephen R. Kratzke,

Associate Administrator for Safety Performance Standards.

[FR Doc. 02-16471 Filed 6-28-02; 8:45 am]

BILLING CODE 4910-59-P

DEPARTMENT OF TRANSPORTATION

Surface Transportation Board

[STB Docket No. AB-6 (Sub-No. 394X)]

The Burlington Northern and Santa Fe Railway Company—Abandonment Exemption—in Burke and Williams Counties, ND

The Burlington Northern and Santa Fe Railway Company (BNSF) has filed a notice of exemption under 49 CFR 1152 subpart F—*Exempt Abandonments* to abandon and discontinue service over a 60.51-mile line of railroad between milepost 26.59 in Powers Lake, and milepost 87.10 in Grenora, in Burke and Williams Counties, ND. The line traverses United States Postal Service Zip Codes 58845, 58856, 58830, 58795, 58755, and 58773.

BNSF has certified that: (1) No local traffic has moved over the line for at least 2 years; (2) there is no overhead traffic to be rerouted; (3) no formal complaint filed by a user of rail service on the line (or by a state or local government entity acting on behalf of such user) regarding cessation of service over the line either is pending with the Surface Transportation Board (Board) or

with any U.S. District Court or has been decided in favor of complainant within the 2-year period; and (4) the requirements at 49 CFR 1105.7 (environmental reports), 49 CFR 1105.8 (historic reports), 49 CFR 1105.11 (transmittal letter), 49 CFR 1105.12 (newspaper publication), and 49 CFR 1152.50(d)(1) (notice to governmental agencies) have been met.

As a condition to this exemption, any employee adversely affected by the abandonment and discontinuance shall be protected under *Oregon Short Line R. Co.—Abandonment—Goshen*, 360 I.C.C. 91 (1979). To address whether this condition adequately protects affected employees, a petition for partial revocation under 49 U.S.C. 10502(d) must be filed. Provided no formal expression of intent to file an offer of financial assistance (OFA) has been received, this exemption will be effective on July 31, 2002, unless stayed pending reconsideration. Petitions to stay that do not involve environmental issues,¹ formal expressions of intent to file an OFA under 49 CFR 1152.27(c)(2),² and trail use/rail banking requests under 49 CFR 1152.29 must be filed by July 11, 2002. Petitions to reopen or requests for public use conditions under 49 CFR 1152.28 must be filed by July 22, 2002, with: Surface Transportation Board, 1925 K Street, NW., Washington, DC 20423.

A copy of any petition filed with the Board should be sent to applicant's representative: Michael Smith, Freeborn & Peters, 311 S. Wacker Dr., Suite 3000, Chicago, IL 60606-6677.

If the verified notice contains false or misleading information, the exemption is void *ab initio*.

BNSF has filed an environmental report which addresses the abandonment's effects, if any, on the environment and historic resources. SEA will issue an environmental assessment (EA) by July 5, 2002. Interested persons may obtain a copy of the EA by writing to SEA (Room 500, Surface Transportation Board, Washington, DC 20423) or by calling SEA, at (202) 565-1552. [TDD for the hearing impaired is available at 1-800-877-8339.] Comments on environmental

¹ The Board will grant a stay if an informed decision on environmental issues (whether raised by a party or by the Board's Section of Environmental Analysis (SEA) in its independent investigation) cannot be made before the exemption's effective date. See *Exemption of Out-of-Service Rail Lines*, 5 I.C.C.2d 377 (1989). Any request for a stay should be filed as soon as possible so that the Board may take appropriate action before the exemption's effective date.

² Each offer of financial assistance must be accompanied by the filing fee, which as of April 8, 2002, is set at \$1,100. See 49 CFR 1002.2(f)(25).

and historic preservation matters must be filed within 15 days after the EA becomes available to the public.

Environmental, historic preservation, public use, or trail use/rail banking conditions will be imposed, where appropriate, in a subsequent decision.

Pursuant to the provisions of 49 CFR 1152.29(e)(2), BNSF shall file a notice of consummation with the Board to signify that it has exercised the authority granted and fully abandoned the line. If consummation has not been effected by BNSF's filing of a notice of consummation by July 1, 2003, and there are no legal or regulatory barriers to consummation, the authority to abandon will automatically expire.

Board decisions and notices are available on our website at WWW.STB.DOT.GOV.

Decided: June 25, 2002.

By the Board, David M. Konschnik,
Director, Office of Proceedings.

Vernon A. Williams,

Secretary.

[FR Doc. 02-16456 Filed 6-28-02; 8:45 am]

BILLING CODE 4915-00-P

DEPARTMENT OF THE TREASURY

[Treasury Order Number 101-05]

Reporting Relationships and Supervision of Officials, Offices and Bureaus, and Delegation of Certain Authority in the Department of the Treasury

By virtue of the authority vested in the Secretary of the Treasury, *it is ordered that:*

1. The Deputy Secretary shall report directly to the Secretary.

2. The Chief of Staff shall report directly to the Secretary and shall exercise supervision over the Director, Secretary's Scheduling Office, and the Executive Secretary.

3. The Executive Secretary shall report directly to the Chief of Staff and shall exercise supervision over the functions of the Executive Secretariat Correspondence Unit; the Office of Public Correspondence; and, for purposes of administrative and managerial control, over the Special Assistant to the Secretary (National Security). The Special Assistant to the Secretary (National Security) shall report to the Secretary and the Deputy Secretary.

4. The following officials shall report through the Deputy Secretary to the Secretary and shall exercise supervision over those officers and organizational entities set forth on the attached organizational chart:

Under Secretary (International Affairs)
 Under Secretary (Domestic Finance)
 Under Secretary (Enforcement)
 General Counsel
 Treasurer of the United States
 Assistant Secretary (Legislative Affairs)
 Assistant Secretary (Public Affairs)
 Assistant Secretary (Economic Policy)
 Assistant Secretary (Tax Policy)
 Assistant Secretary (Management) and
 Chief Financial Officer
 Commissioner of Internal Revenue
 Comptroller of the Currency
 Director, Office of Thrift Supervision
 Director, Bureau of Engraving and
 Printing
 Director, United States Mint

5. The Inspector General and the Treasury Inspector General for Tax Administration shall report to and be under the general supervision of the Secretary and the Deputy Secretary.

6. The Assistant Secretary (Management) also holds the office of the Department's Chief Financial Officer established pursuant to Chapter 9, Title 31, U.S.C., and serves as the Department's Chief Operating Officer for purposes of the Presidential Memorandum, "Implementing Government Reform", dated July 11, 2001.

7. The Deputy Assistant Secretary (Information Systems), reporting to the Assistant Secretary for Management and Chief Financial Officer, is designated as the Department's Chief Information Officer pursuant to Division E of the Clinger-Cohen Act of 1996, and E.O.

13011, dated July 16, 1996, and shall have direct access to the Secretary to the extent required by that Act and related statutes.

8. The Deputy Secretary is authorized, in that official's own capacity and that official's own title, to perform any functions the Secretary is authorized to perform and shall be responsible for referring to the Secretary any matter on which action would appropriately be taken by the Secretary. Any action heretofore taken by the Deputy Secretary in that official's own title is hereby affirmed and ratified as the action of the Secretary.

9. The Under Secretaries, the General Counsel, the Assistant Secretaries, and the Treasurer of the United States are authorized to perform any functions the Secretary is authorized to perform. Each of these officials will ordinarily perform under this authority only those functions that arise out of, relate to, or concern the activities or functions of, or the laws administered by or relating to, the bureaus, offices, or other organizational units over which the incumbent has supervision. Each of these officials shall perform under this authority in the official's own capacity and the official's own title and shall be responsible for referring to the Secretary any matter on which action would appropriately be taken by the Secretary. Any action heretofore taken by any of these officials in that official's own title is hereby affirmed and ratified as the action of the Secretary.

10. The Deputy Secretary shall carry out the duties and powers of the Secretary when the Secretary is absent or unable to serve, or when the office of the Secretary is vacant.

11. During any period when both the Secretary and the Deputy Secretary have died, resigned, or are otherwise unable to perform the functions and duties of the office of the Secretary of the Treasury, those officials designated by the President pursuant to Executive Order 13246, dated December 18, 2001, as amended by Executive Order 13261, dated March 19, 2002, or otherwise designated pursuant to law, shall act as and perform the functions and duties of the office of the Secretary.

12. *Authorities.*

- a. 31 U.S.C. 301 and 321(b); and
- b. Executive Order 13246, dated December 18, 2001, as amended by Executive Order 13261, dated March 19, 2002.

13. *Cancellation.* Treasury Order 101-05, "Reporting Relationships and Supervision of Officials, Offices and Bureaus, Delegation of Certain Authority, and Order of Succession in the Department of the Treasury," dated January 7, 1999, is superseded.

14. *Office of Primary Interest.* Deputy Assistant Secretary (Human Resources).

Paul H. O'Neill,
Secretary of the Treasury.

BILLING CODE 4810-25-P

THE DEPARTMENT OF THE TREASURY

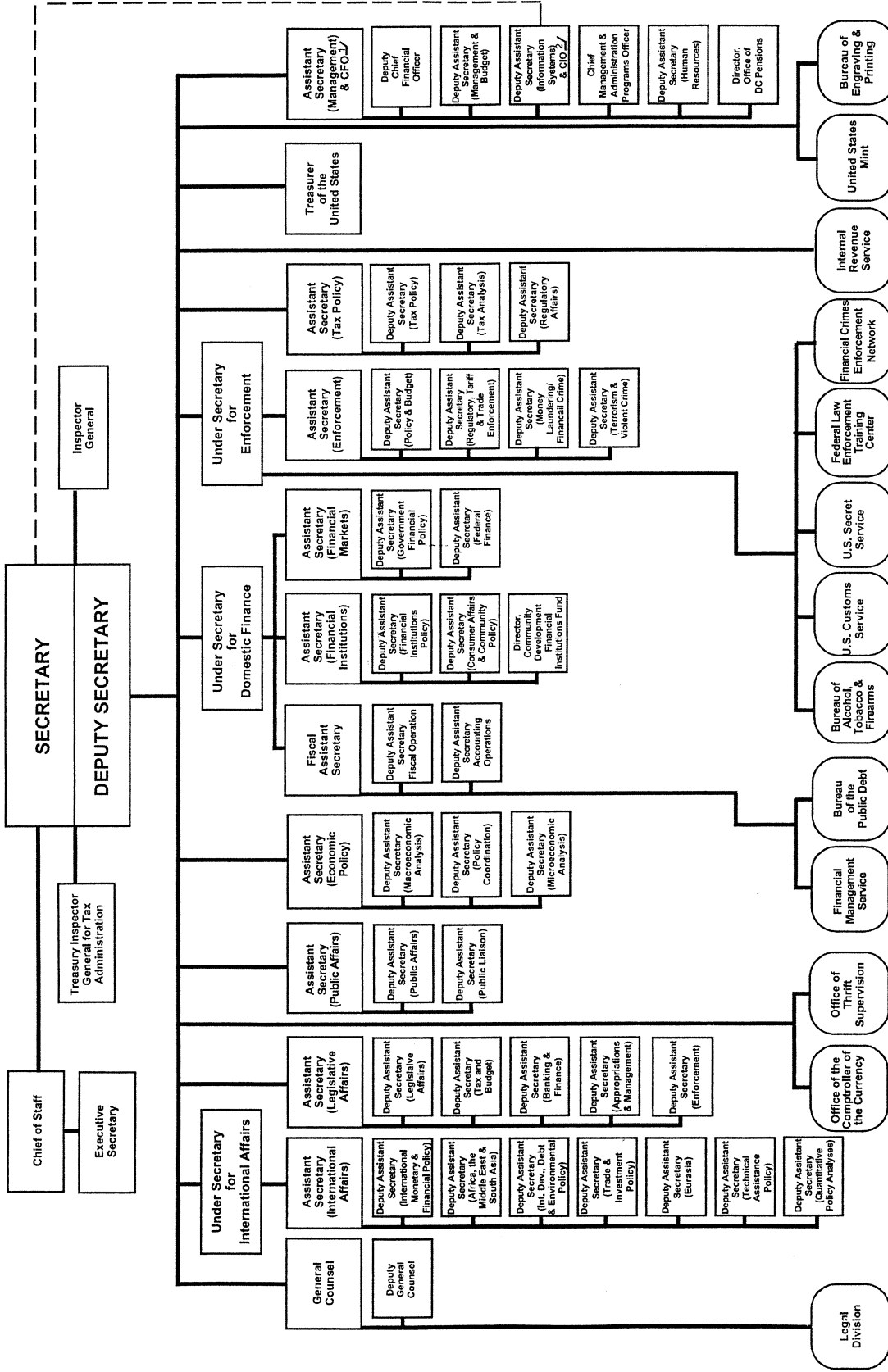

Paul & Service

Approval Signature

TREASURY BUREAUS

1/ Assistant Secretary (Management) and Chief Financial Officer
 is Treasury's Chief Operating Officer.
 2/ Deputy Assistant Secretary (Information Systems) is the Chief Information Officer (CIO)



[FR Doc. 02-16405 Filed 6-28-02; 8:45 am]

BILLING CODE 4810-25-C

DEPARTMENT OF THE TREASURY

Bureau of Engraving and Printing

Proposed Collection; Comment Request

ACTION: Notice and request for comments.

SUMMARY: The Department of the Treasury, as part of its continuing effort to reduce paperwork and respondent burden, invites the general public and other Federal agencies to take this opportunity to comment on proposed and/or continuing information collections, as required by the Paperwork Reduction Act of 1995, Public Law 104-13 (44 U.S.C. 3506(c)(2)(A)). Currently, the Bureau of Engraving and Printing within the Department of the Treasury is soliciting comments concerning the Owner's Affidavit of Partial Destruction of Mutilated Currency.

SUPPLEMENTARY INFORMATION:

Title: Owner's Affidavit of Partial Destruction of Mutilated Currency.

OMB Number: 1520-0001.

Form Number: BEP 5283.

Abstract: This is a request for an extension.

Current Action: The Office of Currency Standards, Mutilated Currency Division, Bureau of Engraving and Printing request owners of partially destroyed U.S. currency to complete a notarized affidavit (BEP 5283) for each claim submitted when substantial portions of notes are missing.

Type of Review: Extension.

Affected Public: Individuals or households.

Estimated Number of Respondents: The estimated number of respondents for the next three years is 180, with a total estimated number of burden hours of 90.

Estimated Total Annual Burden Hours: The estimated number of annual burden hours is 270.

Request for Comments

Comments submitted in response to this notice will be summarized and/or included in the request for OMB approval. All comments will become a matter of public record. Comments are invited on: (a) Whether the collection of information is necessary for the proper performance of the functions of the agency, including whether the information shall have practical utility; (b) the accuracy of the agency's estimate of the burden of the collection of information; (c) ways to enhance the quality, utility, and clarity of the information to be collected; (d) ways to minimize the burden of the collection of information on respondents, including through the use of automated collection techniques or other forms of information technology; and (e) estimates of capital or start-up costs and costs of operation, maintenance, and purchase of services to provide information.

Dated: May 3, 2002.

Pamela Grayson,

Management Analyst, Office of Budget and Strategic Planning, Bureau of Engraving and Printing.

[FR Doc. 02-16414 Filed 6-28-02; 8:45 am]

BILLING CODE 4840-01-M

DEPARTMENT OF THE TREASURY

Fiscal Service

Renegotiation Board Interest Rate; Prompt Payment Interest Rate; Contract Disputes Act

AGENCY: Bureau of the Public Debt, Fiscal Service, Treasury.

ACTION: Notice.

SUMMARY: For the period beginning July 1, 2002 and ending on December 31, 2002 the prompt payment interest rate and the contract dispute interest rate are each 5.250 per centum per annum.

DATES: Comments or inquiries may be mailed to Eleanor Farrar, Team Leader, Debt Accounting Branch, Office of Public Debt Accounting, Bureau of the Public Debt, Parkersburg, West Virginia,

26106-1328. A copy of this Notice will be available to download from <http://www.publicdebt.treas.gov>.

DATES: This notice announces the applicable interest rate for the July 1, 2002 to December 31, 2002 period.

FOR FURTHER INFORMATION CONTACT:

Rank Dunn, Manager, Debt Accounting Branch, Office of Public Debt Accounting, Bureau of the Public Debt, Parkersburg, West Virginia, 26106-1328, (304) 480-5170; Eleanor Farrar, Team Leader, Borrowings Accounting Team, Office of Public Debt Accounting, Bureau of the Public Debt, (304) 480-5166; Edward C. Gronseth, Deputy Chief Counsel, Office of the Chief Counsel, Bureau of the Public Debt, (304) 480-8692; or Mary C. Schaffer, Attorney-Adviser, Office of the Chief Counsel, Bureau of the Public Debt, (304) 480-8692.

SUPPLEMENTARY INFORMATION: Although the Renegotiation Board is no longer in existence, other Federal Agencies are required to use interest rates computed under the criteria established by the Renegotiation Act of 1971 Sec. 2, Pub. L. 92-41, 85 Stat. 97. For example, the Contract Disputes Act of 1978 Sec. 12, Pub. L. 95-563, 92 Stat. 2389 and indirectly, the Prompt Payment Act of 1982, 31 U.S.C. 3902(a), provide for the calculation of interest due on claims at a rate established by the Secretary of the Treasury for the Renegotiation Board under Pub. L. 92-41.

Therefore, notice is given that the Secretary of the Treasury has determined that the rate of interest applicable, for the period beginning July 1, 2002 and ending on December 31, 2002, is 5.250 per centum per annum. This rate is determined pursuant to the above-mentioned sections for the purpose of said sections.

Dated: June 26, 2002.

Donald V. Hammond,

Fiscal Assistant Secretary.

[FR Doc. 02-16602 Filed 6-28-02; 8:45 am]

BILLING CODE 4810-39-M