

AS355E, AS355F, AS355F1, AS355F2, AS355N, AS-365N2, AS-365N3, SA-365N, and SA-365N1 helicopters, with a SIREN load release unit (cargo hook), part number (P/N) AS21-5-1 through -7, and a cargo hook serial number less than 415, installed, certificated in any category.

**Note 1:** This AD applies to each helicopter identified in the preceding applicability provision, regardless of whether it has been otherwise modified, altered, or repaired in the area subject to the requirements of this AD. For helicopters that have been modified, altered, or repaired so that the performance

of the requirements of this AD is affected, the owner/operator must request approval for an alternative method of compliance in accordance with paragraph (b) of this AD. The request should include an assessment of the effect of the modification, alteration, or repair on the unsafe condition addressed by this AD; and if the unsafe condition has not been eliminated, the request should include specific proposed actions to address it.

**Compliance:** Required before the next flight utilizing the cargo hook, unless accomplished previously.

To prevent failure of a cargo hook, inability to release a load creating an additional hazard in an emergency situation, and subsequent loss of control of a helicopter, accomplish the following:

(a) With the cargo hook in the no-load position, measure the clearance "J" in accordance with Figure 1 of this AD. Remove any cargo hook if clearance "J" (see Figure 1) is equal to or greater than 14 millimeters (0.55 inches).

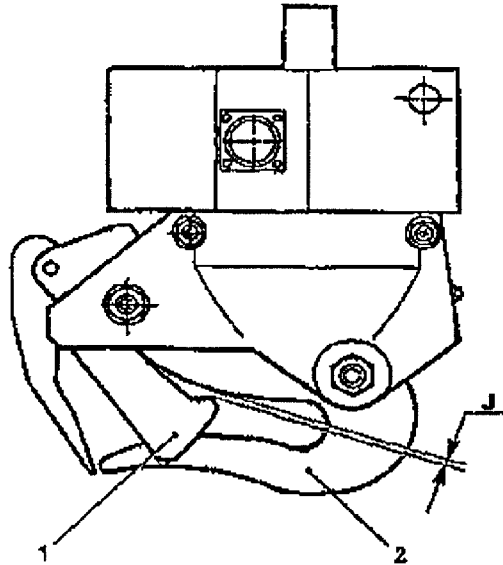

Figure 1

Siren Load Release Unit  
P/N AS21-5-(1 through 7)

1. Locking Catch
2. Cargo Hook

Clearance "J" must be less than 14 mm (0.55 inches)

(b) An alternative method of compliance or adjustment of the compliance time that provides an acceptable level of safety may be used if approved by the Manager, Regulations Group, Rotorcraft Directorate, FAA. Operators shall submit their requests through an FAA Principal Maintenance Inspector, who may concur or comment and then send it to the Manager, Regulations Group.

**Note 2:** Information concerning the existence of approved alternative methods of compliance with this AD, if any, may be obtained from the Regulations Group.

(c) Special flight permits will not be issued allowing use of the affected cargo hook.

**Note 3:** The subject of this AD is addressed in Direction Generale De L'Aviation Civile,

(France) AD 2001-318(A), dated July 25, 2001.

Issued in Fort Worth, Texas, on April 2, 2002.

**Eric Bries,**

*Acting Manager, Rotorcraft Directorate,  
Aircraft Certification Service.*

[FR Doc. 02-8596 Filed 4-9-02; 8:45 am]

**BILLING CODE 4910-13-U**

**DEPARTMENT OF TRANSPORTATION**

**Office of the Secretary**

**14 CFR Part 382**

[OST Docket No. 2002-11473]

**RIN 2105-AD04**

**Reporting Requirements for Disability-Related Complaints**

**AGENCY:** Office of the Secretary, Department of Transportation (DOT).

**ACTION:** Proposed rule; extension of comment period.

**SUMMARY:** The Department of Transportation (DOT or Department) hereby extends the comment period on the proposed rule requiring certain foreign and domestic air carriers to report complaints that they receive alleging inadequate accessibility or discrimination on the basis of disability.

**DATES:** The comment period is extended from April 15, 2002, to June 1, 2002.

**ADDRESSES:** Comments on this action must refer to the docket and notice numbers cited at the beginning of this document and must be submitted to the Docket Management Facility of the Office of the Secretary (OST), located on the Plaza Level of the Nassif Building at the U.S. Department of Transportation, Room PL-401, 400 Seventh Street, SW., Washington, DC 20590-0001. The DOT Docket Facility is open to the public from 9 a.m. to 5 p.m., Monday through Friday. Comments will be available for inspection at this address and will also be viewable via the dockets link on the Department's web site ([www.dot.gov](http://www.dot.gov)). Commenters who wish the receipt of their comments to be acknowledged should include a stamped, self-addressed postcard with their comments. The Docket Clerk will date-stamp the postcard and mail it back to the commenter.

**FOR FURTHER INFORMATION CONTACT:** Jonathan Dols, Office of the General Counsel, Department of Transportation, 400 7th Street, SW., Room 4116, Washington, DC 20590, 202-366-6828 (voice), (202) 366-0511 (TTY), 202-366-7152 (fax), or [jonathan.dols@ost.dot.gov](mailto:jonathan.dols@ost.dot.gov) (email). Arrangements to receive this document in an alternative format may be made by contacting the above named individual.

**SUPPLEMENTARY INFORMATION:** On March 8, 2002, the Air Transport Association of America (ATA) and the Regional Airline Association (RAA) filed a request to extend to June 1, 2002, the comment period on the Department's proposed rule requiring certain foreign and domestic air carriers to report disability-related complaints (see 67 FR 6892, February 14, 2002). In their request, ATA and RAA stated that they and their members need additional time to analyze the proposed rule, to assess its impact, to devise an appropriate survey, and to develop substantive recommendations. They maintain that additional time will yield more insightful comments that will, in turn, improve the final rule. The Department concurs that an extension of the comment period is necessary to allow members of industry sufficient time to analyze the impact of the proposed rule and determines that this extension

would not unduly affect the public's or the government's interest. Moreover, the Department has not received any objection to the extension of time requested by ATA and RAA.

Accordingly, the Department finds that this constitutes good cause to extend the comment period on the proposed rule from April 15, 2002, to June 1, 2002.

Issued in Washington, DC this 3rd day of April, 2002, under authority delegated to me by 14 CFR 385.17(c).

**Robert C. Ashby,**

*Deputy Assistant General Counsel for Regulation and Enforcement, U.S. Department of Transportation.*

[FR Doc. 02-8552 Filed 4-9-02; 8:45 am]

**BILLING CODE 4910-62-P**

## DEPARTMENT OF THE TREASURY

### Internal Revenue Service

#### 26 CFR Part 1

[REG-165706-01]

RIN 1545-BA46

#### Obligations of States and Political Subdivisions

**AGENCY:** Internal Revenue Service (IRS), Treasury.

**ACTION:** Notice of proposed rulemaking and notice of public hearing.

**SUMMARY:** This document contains proposed regulations on the definition of refunding issue applicable to tax-exempt bonds issued by States and local governments. This document provides a notice of public hearing on these proposed regulations.

**DATES:** Written or electronic comments must be received by July 9, 2002. Outlines of topics to be discussed at the public hearing scheduled for July 30, 2002, at 10 a.m., must be received by July 9, 2002.

**ADDRESSES:** Send submissions to: CC:ITA:RU (REG-165706-01), room 5226, Internal Revenue Service, POB 7604, Ben Franklin Station, Washington, DC 20044. Submissions may be hand delivered between the hours of 8 a.m. and 5 p.m. to: CC:ITA:RU (REG-165706-01), courier's desk, Internal Revenue Service, 1111 Constitution Avenue NW., Washington, DC. Alternatively, submissions may be made electronically to the IRS Internet site at [www.irs.gov/regs](http://www.irs.gov/regs). The public hearing will be held in the Auditorium, Internal Revenue Building, 1111 Constitution Avenue NW., Washington, DC.

**FOR FURTHER INFORMATION CONTACT:** Concerning the regulations, Michael P.

Brewer, (202) 622-3980; concerning submissions and the hearing, Treena Garrett, (202) 622-7190 (not toll-free numbers).

#### SUPPLEMENTARY INFORMATION:

##### Background

Section 150 of the Internal Revenue Code (Code) provides certain definitions and special rules for purposes of applying the tax-exempt bond limitations contained in sections 103 and 141 through 150. On June 18, 1993, final regulations (TD 8476) under section 150 were published in the **Federal Register** (58 FR 33510). On May 9, 1997, additional final regulations (TD 8718) under section 150 were published in the **Federal Register** (62 FR 25502). This document proposes to modify the definition of refunding issue under § 1.150-1(d).

##### Explanation of Provisions

Section 1.150-1(d) of the current regulations provides a definition of *refunding issue*. In general, a refunding issue is an issue of obligations the proceeds of which are used to pay principal, interest, or redemption price on another issue. The current regulations contain certain exceptions to this general rule. One exception (the *change in obligor exception*) provides that an issue is not a refunding issue to the extent that the obligor of one issue is neither the obligor of the other issue nor a related party with respect to the obligor of the other issue. Another exception (the *six-month exception*) provides that if a person assumes (including taking subject to) obligations of an unrelated party in connection with an asset acquisition (other than a transaction to which section 381(a) applies if the person assuming the obligation is the acquiring corporation within the meaning of section 381(a)), and the assumed issue is refinanced within six months before or after the date of the debt assumption, the refinancing issue is not treated as a refunding issue.

Section 1.150-1(b) of the current regulations provides that the term *related party* means, in reference to a governmental unit or a 501(c)(3) organization, any member of the same controlled group. Section 1.150-1(e) of the current regulations provides that the term *controlled group* means a group of entities controlled directly or indirectly by the same entity or group of entities. The determination of control is made on the basis of all the relevant facts and circumstances. One entity or group of entities (the *controlling entity*) generally controls another entity or group of