

AD. For helicopters that have been modified, altered, or repaired so that the performance of the requirements of this AD is affected, the owner/operator must request approval for an alternative method of compliance in accordance with paragraph (c) of this AD. The request should include an assessment of the effect of the modification, alteration, or repair on the unsafe condition addressed by this AD; and if the unsafe condition has not been eliminated, the request should include specific proposed actions to address it.

Compliance: Required as indicated, unless accomplished previously.

To prevent loss of the tail rotor gearbox due to attaching bolts of inadequate grip

length and subsequent loss of control of the helicopter, accomplish the following:

(a) Within 25 hours time-in-service (TIS), conduct the following inspections:

(1) For each tail rotor gearbox attaching bolt (bolt):

(i) Determine the part number (P/N).

(ii) If the P/N cannot be determined or if the bolt is not P/N NAS1304-26, before further flight, replace the bolt with bolt, P/N NAS1304-26.

(iii) Torque the bolt to 100-110 in-lbs and apply a slippage mark.

(2) Remove the tailboom control rod and determine the number of bolt threads protruding from each nutplate on the internal surface of the aft tailboom frame casting, P/

N 369D23503, as shown in Figure 1. At least one thread must protrude. If more than four threads protrude, add an additional washer, P/N AN960D416, under the bolt head. Torque the bolt to 100-110 in-lbs., and reapply a slippage mark.

(b) Between 2 and 10 hours TIS after accomplishing the requirements of paragraph (a) of this AD, inspect the torque on each bolt by applying 100 in-lbs. If any bolt movement occurs, retorquer the bolt to 100-110 in-lbs. and reapply a slippage mark. Reinspect the torque between 2 and 10 hours TIS thereafter until no bolt movement occurs.

Note 2: Aerometals Service Bulletin SB-001, dated August 3, 2000, pertains to the subject of this AD.

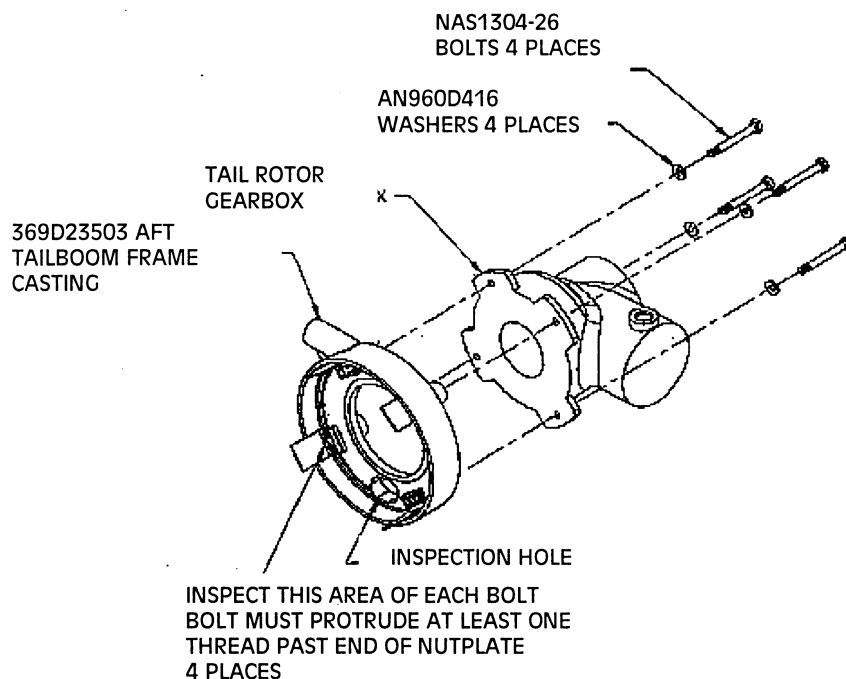

Figure 1 – Inspection Location

(c) An alternative method of compliance or adjustment of the compliance time that provides an acceptable level of safety may be used if approved by the Manager, Los Angeles Aircraft Certification Office (LAACO), FAA. Operators shall submit their requests through an FAA Principal Maintenance Inspector, who may concur or comment and then send it to the Manager, LAACO.

Note 3: Information concerning the existence of approved alternative methods of compliance with this AD, if any, may be obtained from the LAACO.

(d) Special flight permits will not be issued.

Issued in Fort Worth, Texas, on December 14, 2001.

David A. Downey,

Manager, Rotorcraft Directorate, Aircraft Certification Service.

[FR Doc. 01-31556 Filed 12-26-01; 8:45 am]

BILLING CODE 4910-13-U

DEPARTMENT OF TRANSPORTATION

Federal Aviation Administration

14 CFR Part 39

[Docket No. 2001-CE-36-AD]

RIN 2120-AA64

Airworthiness Directives; Air Tractor, Inc. AT-400, AT-500, and AT-800 Series Airplanes

AGENCY: Federal Aviation Administration, DOT.

ACTION: Notice of proposed rulemaking (NPRM).

SUMMARY: This document proposes to supersede Airworthiness Directive (AD) 2001-10-04 R1, which lowered the safe life for the wing lower spar cap on

certain Air Tractor, Inc. (Air Tractor) AT-400, AT-500, and AT-800 series airplanes. AD 2001-10-04 R1 resulted from numerous reports of cracks in the 3/8-inch bolthole of the wing lower spar cap on the affected airplanes. This proposed AD would maintain the safe life and add a requirement for you to eddy—current inspect the wing lower spar cap immediately prior to the replacement/modification in order to detect and correct any crack in a bolthole before it extends to the modified center section of the wing and repair that crack or replace the wing section. This proposed AD would also further reduce the safe life for certain AT-400 and AT-500 series airplanes that incorporate or have incorporated Marburger Enterprises, Inc. winglets. These winglets are installed in accordance with Supplemental Type Certificate (STC) SA00490LA. The actions specified by this proposed AD are intended to prevent fatigue cracks from occurring in the wing lower spar cap before the originally-established safe life is reached. Fatigue cracks in the wing lower spar cap, if not detected and corrected, could result in the wing separating from the airplane during flight.

DATES: The Federal Aviation Administration (FAA) must receive any comments on this proposed rule on or before February 15, 2002.

ADDRESSES: Submit comments to FAA, Central Region, Office of the Regional Counsel, Attention: Rules Docket No. 2001-CE-36-AD, 901 Locust, Room 506, Kansas City, Missouri 64106. You may view any comments at this location between 8 a.m. and 4 p.m., Monday through Friday, except Federal holidays.

You may get service information that applies to this proposed AD from Air Tractor, Incorporated, P.O. Box 485, Olney, Texas 76374; or Marburger Enterprises, Inc., 1227 Hillcourt, Williston, North Dakota 58801; telephone: (800) 893-1420 or (701) 774-0230; facsimile: (701) 572-2602. You may also view this information at the Rules Docket at the address above.

FOR FURTHER INFORMATION CONTACT: Direct all questions to:

- For the airplanes that do not incorporate and never have incorporated Marburger Enterprises, Inc. winglets: Rob Romero, Aerospace Engineer, FAA, Fort Worth Airplane Certification Office, 2601 Meacham Boulevard, Fort Worth, Texas 76193-0150; telephone: (817) 222-5102; facsimile: (817) 222-5960; and
- For certain AT-400 and AT-500 series airplanes that incorporate or have incorporated Marburger

Enterprises, Inc. winglets: John Cecil, Aerospace Engineer, Los Angeles Aircraft Certification Office, FAA, 3960 Paramount Boulevard, Lakewood, California, 90712; telephone: (562) 627-5228; facsimile: (562) 627-5210.

SUPPLEMENTARY INFORMATION:

Comments Invited

How do I comment on this proposed AD? The FAA invites comments on this proposed rule. You may submit whatever written data, views, or arguments you choose. You need to include the rule's docket number and submit your comments to the address specified under the caption **ADDRESSES**. We will consider all comments received on or before the closing date. We may amend this proposed rule in light of comments received. Factual information that supports your ideas and suggestions is extremely helpful in evaluating the effectiveness of this proposed AD action and determining whether we need to take additional rulemaking action.

Are there any specific portions of this proposed AD I should pay attention to? The FAA specifically invites comments on the overall regulatory, economic, environmental, and energy aspects of this proposed rule that might suggest a need to modify the rule. You may view all comments we receive before and after the closing date of the rule in the Rules Docket. We will file a report in the Rules Docket that summarizes each contact we have with the public that concerns the substantive parts of this proposed AD.

How can I be sure FAA receives my comment? If you want FAA to acknowledge the receipt of your comments, you must include a self-addressed, stamped postcard. On the postcard, write "Comments to Docket No. 2001-CE-36-AD." We will date stamp and mail the postcard back to you.

Discussion

Has FAA taken any action to this point? Several reports of cracked wing lower spar caps on Air Tractor AT-400, AT-500, and AT-800 series airplanes have caused the manufacturer (Air Tractor) to recalculate the fatigue life of the wing lower spar cap on these airplanes. One report was of an accident where the wing separated from the airplane during flight. The cracks are originating in the outboard 3/8-inch bolthole of the wing lower spar cap.

To address this condition, FAA issued AD 2001-10-04, Amendment 39-12230 (66 FR 27014, May 16, 2001). This AD lowers the safe life for the wing lower spar cap on Air Tractor AT-400, AT-

500, and AT-800 series airplanes. This AD also allows for inspection, using eddy current methods, of the wing lower spar cap for airplanes that are at or over the lower safe life and parts are not available. Operation of the airplane is not allowed if cracks are found and inspections must be terminated when parts become available or after performing three repetitive inspections.

AD 2001-10-04 superseded AD 2000-14-51, Amendment 39-11837 (65 FR 46567, July 31, 2000). AD 2000-14-51 required inspection of the wing lower spar cap for cracks on Air Tractor Models AT-501, AT-502, and AT-502A airplanes, and modification or replacement of any cracked wing lower spar cap.

We inadvertently included certain AT-800 series airplanes in the Applicability of AD 2001-10-04. Those AT-800 series airplanes that are equipped with the factory-supplied part number 80540 computerized fire gate should not be affected by AD 2001-10-04. Therefore, we revised this AD to incorporate this change. AD 2001-10-04 R1, Amendment 39-12247, was published in the **Federal Register** on June 4, 2001 (66 FR 29900).

What has happened since AD 2001-10-04 R1 to initiate this action? In response to AD 2001-10-04 R1, FAA received a comment from the National Transportation Safety Board that recommended an eddy-current inspection requirement immediately prior to the accomplishment of the two-part modification described in Snow Engineering Service Letters #197, #202, #203, or #205, all Revised March 26, 2001, as applicable. This is to eliminate the possibility that a crack that exists in a bolt hole prior to the modification is still present after accomplishing the modification. Prior to the modification, any crack present will be larger than it would appear after the outermost bolt holes are enlarged. This makes the crack easier to detect and gives the mechanic an area to concentrate on any post-modification inspections.

Additional analysis also indicates a higher wing root bending moment that could lead to reduction of the safe life for certain AT-400 and AT-500 series airplanes with a certain configuration. Airplanes with this configuration either incorporate or have incorporated Marburger Enterprises, Inc. winglets on the wing lower spar cap. These winglets are installed in accordance with Supplemental Type Certificate (STC) SA00490LA. We have developed criteria for determining what the new safe life should be for airplanes that either incorporate or have incorporated these winglets.

The FAA's Determination and an Explanation of the Provisions of this Proposed AD

What has FAA decided?

After examining the circumstances and reviewing all available information related to the incidents described above, we have determined that:

- The unsafe condition referenced in this document exists or could develop on other AT-400, AT-500, and AT-800 series airplanes (specific models as referenced in the AD) of the same type design;
- All airplanes should have the eddy-current inspection accomplished on the wing lower spar cap immediately prior to the replacement/modification

in order to detect and correct any crack in a bolthole before it extends to the modified center section of the wing;

- Certain AT-400 and AT-500 series airplanes that incorporate or have incorporated Marburger Enterprises, Inc. winglets should have the safe life further reduced; and
- AD action should be taken in order to correct this unsafe condition.

What would this proposed AD require? This proposed AD would supersede AD 2001-10-04 R1 with a new AD that would maintain the safe life and would add a requirement for you to eddy-current inspect the wing lower spar cap immediately prior to the replacement/modification in order to detect and correct any crack in a

bolthole before it extends to the modified center section of the wing and repair that crack or replace the wing section. The proposed AD would also further reduce the safe life for those AT-400 and AT-500 series airplanes that incorporate or have incorporated Marburger Enterprises, Inc. winglets.

Cost Impact

How many airplanes would this proposed AD impact? We estimate that this proposed AD affects 1,179 airplanes in the U.S. registry.

What would be the cost impact of this proposed AD on owners/operators of the affected airplanes? We estimate the following costs to accomplish the proposed inspection:

Labor cost	Parts cost	Total cost per airplane	Total cost on U.S. operators
2 workhours at \$60 per hour = \$120	No parts required for inspection.	\$120	\$141,480

We estimate the following costs to accomplish the proposed replacement/modification:

Labor cost	Parts cost	Total cost Per Airplane	Total cost on U.S. operators
210 workhours at \$60 per hour = \$7,200	\$11,500	\$18,700	\$22,047,300

What is the difference between the cost impact of this proposed AD and the cost impact of AD 2001-10-04 R1? AD 2001-10-04 R1 already established the safe life for the lower wing spar cap on the affected airplanes. Therefore, the replacement/modification is already required through that AD. The only difference in the cost impact upon the public of this proposed AD and AD 2001-10-04 R1 is the cost for the eddy-current inspection upon replacement and the further safe life reduction for those AT-400 and AT-500 series airplanes that incorporate or have incorporated Marburger Enterprises, Inc. winglets.

Regulatory Impact

Would this proposed AD impact various entities? The regulations proposed herein would not have a substantial direct effect on the States, on the relationship between the national government and the States, or on the distribution of power and responsibilities among the various levels of government. Therefore, it is determined that this proposed rule would not have federalism implications under Executive Order 13132.

Would this proposed AD involve a significant rule or regulatory action? For the reasons discussed above, I certify that this proposed action (1) is not a "significant regulatory action" under Executive Order 12866; (2) is not a "significant rule" under DOT Regulatory Policies and Procedures (44 FR 11034, February 26, 1979); and (3) if promulgated, will not have a significant economic impact, positive or negative, on a substantial number of small entities under the criteria of the Regulatory Flexibility Act. A copy of the draft regulatory evaluation prepared for this action has been placed in the Rules Docket. A copy of it may be obtained by contacting the Rules Docket at the location provided under the caption **ADDRESSES**.

List of Subjects in 14 CFR Part 39

Air transportation, Aircraft, Aviation safety, Safety.

The Proposed Amendment

Accordingly, under the authority delegated to me by the Administrator, the Federal Aviation Administration proposes to amend part 39 of the

Federal Aviation Regulations(14 CFR part 39) as follows:

PART 39—AIRWORTHINESS DIRECTIVES

1. The authority citation for part 39 continues to read as follows:

Authority: 49 U.S.C. 106(g), 40113, 44701.

§ 39.13 [Amended]

2. FAA amends § 39.13 by removing Airworthiness Directive (AD) 2001-10-04 R1, Amendment 39-12247 (66 FR 29900, June 4, 2001), and by adding a new AD to read as follows:

Air Tractor, Inc.: Docket No. 2001-CE-36-AD; Supersedes AD 2001-10-04 R1, Amendment 39-12247.

(a) *What airplanes are affected by this AD?* Use paragraph (a)(1) of this AD for airplanes that do not incorporate and never have incorporated winglets and use paragraph (a)(2) of this AD for certain AT-400 and AT-500 series airplanes that incorporate or have incorporated Marburger Enterprises, Inc. winglets.

(1) The following presents airplanes (certificated in any category) that are affected by this AD, along with the new safe life (presented in hours time-in-service (TIS)) of the wing lower spar cap for all airplane models and serial numbers:

Model	Serial Nos.	Safe life
AT-400	all serial numbers beginning with 0416	13,300 hours TIS.
AT-401	0662 through 0951	10,757 hours TIS.
AT-401B	0952 through 1014 and 1016 through 1020	6,948 hours TIS.
AT-401B	1015 and 1021 through 1124	7,777 hours TIS.
AT-402	0694 through 0951	7,440 hours TIS.
AT-402A	0738 through 0951	7,440 hours TIS.
AT-402A	0952 through 1020	4,589 hours TIS.
AT-402A	1021 through 1124	5,268 hours TIS.
AT-402B	0966 through 1020	4,589 hours TIS.
AT-402B	1021 through 1124	5,268 hours TIS.
AT-501	0002 through 0061	4,531 hours TIS.
AT-501	all serial numbers beginning with 0062	7,693 hours TIS.
AT-502	0003 through 0236	4,000 hours TIS.
AT-502A	0158 through 0618	3,000 hours TIS.
AT-502B	0187 through 0618	4,000 hours TIS.
AT-503A	all serial numbers beginning with 0067	4,000 hours TIS.
AT-802	0001 through 0059 except those equipped with the factory-supplied part number 80540 computerized fire gate.	4,132 hours TIS.
AT-802	0060 through 0091 except those equipped with the factory-supplied part number 80540 computerized fire gate.	4,188 hours TIS.
AT-802	0092 through 0101 except those equipped with the factory-supplied part number 80540 computerized fire gate.	8,163 hours TIS.
AT-802A	0003 through 0059 except those equipped with the factory-supplied part number 80540 computerized fire gate.	4,969 hours TIS.
AT-802A	0060 through 0091 except those equipped with the factory-supplied part number 80540 computerized fire gate.	4,531 hours TIS.
AT-802A	0092 through 0101 except those equipped with the factory-supplied part number 80540 computerized fire gate.	8,648 hours TIS.

Note 1: Piston powered aircraft that have been converted to turbine power should use the limits for corresponding serial number turbine-powered aircraft.

(2) The following presents airplanes (certificated in any category) that could incorporate or could have incorporated Marburger Enterprises, Inc. winglets. These winglets are installed in accordance with Supplemental Type Certificate (STC)

SA00490LA. Use the winglet usage factor in the table below, the safe life specified in paragraph (a)(1) of this AD, and the instructions included in the Appendix to this AD to determine the new safe life of these airplanes:

Model	Serial Nos.	Winglet usage factor
AT-401	0662 through 0951	1.6
AT-401B	0952 through 1014 and 1016 through 1020	1.1
AT-401B	1015 and 1021 through 1124	1.1
AT-402	0694 through 0951	1.6
AT-402A	0738 through 0951	1.6
AT-402A	0952 through 1020	1.1
AT-402A	1021 through 1124	1.1
AT-402B	0966 through 1020	1.1
AT-402B	1021 through 1124	1.1
AT-501	0002 through 0061	1.6
AT-501	All serial numbers beginning with 0062	1.6
AT-502	0003 through 0236	1.6
AT-502A	0158 through 0618	1.6
AT-502B	0187 through 0618	1.2

(b) *Who must comply with this AD?*
Anyone who wishes to operate any of the above airplanes must comply with this AD.

(c) *What problem does this AD address?*
The actions specified by this AD are intended to prevent fatigue cracks from occurring in

the wing lower spar cap before the originally-established safe life is reached. Fatigue cracks in the wing lower spar cap, if not detected and corrected, could result in the wing separating from the airplane during flight.

(d) *What must I do to address this problem?* To address this problem, you must accomplish the following actions:

Note 2: The 10-hour time-in-service (TIS) compliance time is maintained from AD 2001-10-04 R1.

Action	Compliance time	Procedures
<p>(1) Modify the applicable aircraft records as follows to show the reduced safe life for the wing lower spar cap (use the information from the table in paragraph (a)(1) of this AD and utilize the information in paragraph (a)(2) of and the Appendix to this AD, as applicable):</p> <p>(i) For the affected Models AT-802 and AT-802A airplanes: update the Owners Manual, Section 6—Airworthiness Limitations, Life Limited Parts.</p> <p>(ii) For all affected airplanes other than the Models AT-802 and AT-802A airplanes: incorporate the following into the Aircraft Logbook “In accordance with this AD, the wing lower spar cap is life limited to _____ (insert the applicable safe life number from the applicable tables in paragraphs (a)(1) and (a)(2) of this AD).</p> <p>(iii) If, as of the time of the logbook all entry requirement of paragraph (d)(1) of this AD, your airplane is over or within 10 hours of the safe life, an additional 10 hours TIS is allowed to accomplish the replacement/modification</p>	<p>Accomplish the logbook entry within the next 10 hours TIS after the effective date of this AD.</p>	<p>The owner/operator holding at least a private pilot certificate as authorized by section 43.7 of the Federal Aviation Regulations (14 CFR 43.7) may modify the aircraft records as specified in paragraphs (d)(1)(i) and (d)(1)(ii) of this AD. Make an entry into the aircraft records showing compliance with this portion of the AD in accordance with section 43.9 of Federal the Aviation Regulations (14 CFR 43.9). Accomplish the actual replacement/modification in accordance with Snow Engineering Service Letter #197, #202, #203, or #205, Revised March 26, 2001, as applicable. The owner/operator may not accomplish the replacement/modification.</p>
<p>(2) If you have ordered parts from the factory when it is time to replace the wing lower spar cap (as required per the logbook safe life reduction in paragraph (d)(1) of this AD), but the parts are not available, you may eddy-current inspect the wing lower spar cap. These inspections are allowed until one of the following occurs, at which time the replacement/modification (required when the lower spar cap has reached its safe life) must be accomplished:</p> <p>(i) Crack(s) is/are found;</p> <p>(ii) Parts become available from the manufacturer; or</p> <p>(iii) Not more than three inspections or 1,200 hours TIS go by: the first inspection would have to be accomplished upon accumulating the safe life; the second inspection would have to be accomplished within 400 hours TIS after accumulating the safe life; the third inspection would have to be accomplished 400 hours TIS after the second inspection; and the replacement/modification would have to be accomplished within 400 hours TIS after the third inspection (maximum elapsed time would be 1,200 hours TIS)</p>	<p>Prior to further flight after ordering the parts and thereafter at intervals not to exceed 400 hours TIS until one of the criteria paragraphs (d)(2)(i), (d)(2)(ii), and (d)(2)(iii) of this AD is met.</p>	<p>In accordance with the procedures in Snow Engineering Service Letter #197, #202, #203, or #205, all Revised March 26, 2001, as applicable.</p>
<p>(3) Eddy-current inspect the wing lower spar cap in order to detect and correct any crack before it extends to the modified center section of the wing and repair that crack or replace the wing section</p>	<p>Immediately prior to the replacement/modification required when you reach the new safe life. For airplanes that had this replacement/modification accomplished in accordance with either AD 2001-10-04 or AD 2001-10-04 R1, accomplish this inspection and any necessary corrective action within the next 400 hours TIS after the effective date of this AD, unless already accomplished (have the mechanic who accomplished the work mark the logbooks accordingly).</p>	<p>In accordance with the procedures in Snow Engineering Service Letter #197, #202, #203, or #205, all Revised March 26, 2001, as applicable.</p>

(e) *Can I comply with this AD in any other way?* (1) You may use an alternative method of compliance or adjust the compliance time if:

(i) Your alternative method of compliance provides an equivalent level of safety; and

(ii) The Manager, Fort Worth or Los Angeles Airplane Certification Office (ACO), as applicable, approves your alternative. Submit your request through an FAA Principal Maintenance Inspector. The inspector may add comments before sending

it to the Manager, Fort Worth or Los Angeles ACO.

(2) Alternative methods of compliance approved for AD 2001-10-04 and/or AD 2000-14-51 are not considered approved for this AD.

(3) Alternative methods of compliance approved for AD 2001-10-04 R1 are considered approved for this AD.

Note 3: This AD applies to each airplane identified in paragraphs (a)(1) and (a)(2) of this AD, regardless of whether it has been modified, altered, or repaired in the area subject to the requirements of this AD. For airplanes that have been modified, altered, or repaired so that the performance of the requirements of this AD is affected, the owner/operator must request approval for an alternative method of compliance in accordance with paragraph (e) of this AD. The request should include an assessment of the effect of the modification, alteration, or repair on the unsafe condition addressed by this AD; and, if you have not eliminated the unsafe condition, specific actions you propose to address it.

(f) *Are there any alternative methods of compliance already approved or being considered for this AD?* The FAA may approve, as an alternative method of compliance, inspection of the wing lower spar cap. You must submit the request in accordance with the procedures in paragraph (e) of this AD and adhere to the following:

(1) If you are over or within 10 hours TIS of the safe life for the wing lower spar cap and you have ordered parts and scheduled a date for the replacement/modification, but having the replacement/modification done on this date grounds the airplane, accomplish the following:

(i) Inspect the wing lower spar cap within 10 hours TIS after approval of the alternative method of compliance;

(ii) Reinspect thereafter at intervals not to exceed 400 hours TIS until either cracks are found, the date of the scheduled replacement/modification occurs, or 1,200 hours TIS after the initial inspection are accumulated, whichever occurs first; and

(iii) Accomplish the inspections in accordance with the procedures in Snow Engineering Service Letter #197, #202, #203, or #205, all Revised March 26, 2001, as applicable.

(2) Submit the following to the Fort Worth or Los Angeles ACO, as applicable, using the procedures described in paragraph (e) of this AD:

(i) The airplane model serial number designation, and airplane registration number (N-number);

(ii) The number of hours TIS on the airplane;

(iii) The scheduled date for the replacement/modification; and

(iv) The name and location of the authorized repair shop.

(3) For more information about this issue, contact:

(i) For the airplanes that do not incorporate and never have incorporated Marburger Enterprises, Inc. winglets: Rob Romero, Aerospace Engineer, FAA, Fort Worth Airplane Certification Office, 2601 Meacham Boulevard, Fort Worth, Texas 76193-0150; telephone: (817) 222-5102; facsimile: (817) 222-5960; and

(ii) For the airplanes that incorporate or have incorporated winglets: John Cecil, Aerospace Engineer, Los Angeles Aircraft Certification Office, FAA, 3960 Paramount

Boulevard, Lakewood, California, 90712; telephone: (562) 627-5228; facsimile: (562) 627-5210.

(g) *What if I need to fly the airplane to another location to comply with this AD?* The FAA can issue a special flight permit under sections 21.197 and 21.199 of the Federal Aviation Regulations (14 CFR 21.197 and 21.199) to operate your airplane to a location where you can accomplish the requirements of this AD provided that the following is adhered to:

(1) Only operate in day visual flight rules (VFR) only.

(2) Ensure that the hopper is empty.

(3) Limit airspeed to 135 miles per hour (mph) indicated airspeed (IAS).

(4) Avoid any unnecessary g-forces.

(5) Avoid areas of turbulence.

(6) Plan the flight to follow the most direct route.

(h) *How do I get copies of the documents referenced in this AD?* You may get copies of the documents referenced in this AD from Air Tractor, Incorporated, P.O. Box 485, Olney, Texas 76374; or Marburger Enterprises, Inc., 1227 Hillcourt, Williston, North Dakota 58801; telephone: (800) 893-1420 or (701) 774-0230; facsimile: (701) 572-2602. You may view these documents at FAA, Central Region, Office of the Regional Counsel, 901 Locust, Room 506, Kansas City, Missouri 64106.

Appendix to Docket No. 2001-CE-36-AD

The following provides procedures for determining the safe life for those AT-400 and AT-500 series airplanes that incorporate or have incorporated Marburger Enterprises, Inc. winglets. These winglets are installed in accordance with Supplemental Type Certificate (STC) SA00490LA.

1. Review your airplane's logbook to determine your airplane's time in service (TIS) with winglets installed per Marburger Enterprises STC SA00490LA. This includes all time spent with the winglets currently installed and any previous installations where the winglet was installed and later removed.

Example: A review of your airplane's logbook shows that you have accumulated 350 hours TIS since incorporating the Marburger STC. Further review of the airplane's logbook shows that a previous owner had installed the STC and later removed the winglets after accumulating 150 hours TIS. Therefore, your airplane's TIS with the winglets installed is 500 hours.

If you determine that the winglet STC has never been incorporated on your airplane, then your safe life is presented in paragraph (a)(1) of this AD. Any future winglet installation would be subject to a reduced safe life per these instructions.

2. Determine your airplane's unmodified safe life from paragraph (a)(1) of this AD.

Example: Your airplane is a Model AT-502B, serial number 0292. From paragraph (a)(1) of this AD, the safe-life of your airplane is 4,000 hours TIS. All examples from hereon will be based on the Model AT-502B, serial number 0292 airplane.

3. Determine the winglet usage factor from paragraph (a)(2) of this AD.

Example: Again, your airplane is a Model AT-502B, serial number 0292. From paragraph (a)(2) of this AD, your winglet usage factor is 1.2.

4. Adjust the winglet TIS to account for the winglet usage factor. Multiply the winglet TIS (result of 1.) by the winglet usage factor (result of 3.).

Example: Winglet TIS is 500 hours X a winglet usage factor of 1.2. The adjusted winglet TIS is 600 hours.

5. Calculate the winglet usage penalty. Subtract the winglet TIS (result of 1.) from the adjusted winglet TIS (result of 4.).

Example: Adjusted winglet TIS is 600 hours—the winglet TIS of 500 hours. The winglet usage penalty is 100 hours TIS.

6. Adjust the safe life of your airplane to account for winglet usage. Subtract the winglet usage penalty (result of 5.) result from the unmodified safe life from paragraph (a)(1) of this AD (the result of 2.).

Example: The unmodified safe life is 4,000 hours TIS – the 100 hours TIS usage penalty = 3,900 hours TIS adjusted safe life.

7. If you remove the winglets from your airplane prior to further flight or no longer have the winglets installed on your airplane, the safe life of your airplane is the adjusted safe life (result of 6.). Enter this number in paragraph (d)(1) of this AD and the airplane logbook.

8. If you keep the current winglet installation on your airplane, you must further reduce the safe life by dividing the adjusted safe life (result of 6.) by the winglet usage factor (result of 3.). Record this result in your airplane's logbook.

Example: Adjusted safe life is 3,900 hours ÷ winglet usage factor of 1.2 = 3,250 hours TIS.

9. If, at anytime in the future, you install or remove the Marburger winglet STC from your airplane, you must repeat the procedures in this Appendix.

Issued in Kansas City, Missouri, on December 17, 2001.

Michael Gallagher,
Manager, Small Airplane Directorate, Aircraft Certification Service.

[FR Doc. 01-31555 Filed 12-26-01; 8:45 am]

BILLING CODE 4910-13-P

DEPARTMENT OF TRANSPORTATION

Federal Aviation Administration

14 CFR Part 39

[Docket No. 2001-CE-47-AD]

RIN 2120-AA64

Airworthiness Directives; Fairchild Aircraft, Inc. Models SA226 and SA227 Series Airplanes

AGENCY: Federal Aviation Administration, DOT.

ACTION: Notice of proposed rulemaking (NPRM).

SUMMARY: This document proposes to supersede Airworthiness Directive (AD)