

structure have been accomplished in accordance either of the following AD's:

- AD 95-13-05, amendment 39-9285 (60 FR 33333, June 28, 1995), or
- AD 95-13-06, amendment 39-9286 (60 FR 33338, June 28, 1995).

Note 1: This AD applies to each airplane identified in the preceding applicability provision, regardless of whether it has been otherwise modified, altered, or repaired in the area subject to the requirements of this AD. For airplanes that have been modified, altered, or repaired so that the performance of the requirements of this AD is affected, the owner/operator must request approval for an alternative method of compliance in accordance with paragraph (c) of this AD. The request should include an assessment of the effect of the modification, alteration, or repair on the unsafe condition addressed by this AD; and, if the unsafe condition has not been eliminated, the request should include specific proposed actions to address it.

Compliance: Required as indicated, unless accomplished previously.

To prevent cracking or corrosion of the fuse pins of the nacelle strut, which could result in failure of the fuse pin and strut-to-wing attachment, and consequent loss of the strut and separation of the engine from the airplane, accomplish the following:

(a) Within 10 months after the effective date of this AD, replace the fuse pins in the upper link, midspar fittings, and diagonal brace of the nacelle strut with new corrosion-resistant pins, in accordance with the Accomplishment Instructions of Boeing Service Bulletin 747-54-2155, Revision 2, dated June 6, 1996.

Note 2: Replacement of the fuse pins accomplished prior to the effective date of this AD in accordance with the Accomplishment Instructions of Boeing Service Bulletin 747-54-2155, dated September 23, 1993, or Revision 1, dated December 8, 1994, is considered acceptable for compliance with the applicable action specified in this amendment.

Note 3: All fuse pins in the strut do not have to be replaced at the same time; however, the fuse pins do have to be replaced in sets, as specified in Boeing Service Bulletin 747-54-2155, Revision 2, dated June 6, 1996.

(b) Accomplishment of the replacement of the fuse pins specified in paragraph (a) of this AD constitutes terminating action for the repetitive inspections of the fuse pins of the upper link, required by AD 97-14-06, amendment 39-10064; of the fuse pins of the midspar fitting, required by AD 92-24-51, amendment 39-8439; and of the fuse pins of the diagonal brace, required by AD 93-03-14, amendment 39-8518.

Alternative Methods of Compliance

(c) An alternative method of compliance or adjustment of the compliance time that provides an acceptable level of safety may be used if approved by the Manager, Seattle Aircraft Certification Office (ACO), FAA, Transport Airplane Directorate. Operators shall submit their requests through an appropriate FAA Principal Maintenance Inspector, who may add comments and then send it to the Manager, Seattle ACO.

Note 4: Information concerning the existence of approved alternative methods of compliance with this AD, if any, may be obtained from the Seattle ACO.

Special Flight Permits

(d) Special flight permits may be issued in accordance with sections 21.197 and 21.199 of the Federal Aviation Regulations (14 CFR 21.197 and 21.199) to operate the airplane to a location where the requirements of this AD can be accomplished.

Incorporation by Reference

(e) The replacement shall be done in accordance with Boeing Service Bulletin 747-54-2155, Revision 2, dated June 6, 1996. This incorporation by reference was approved by the Director of the Federal Register in accordance with 5 U.S.C. 552(a) and 1 CFR part 51. Copies may be obtained from Boeing Commercial Airplane Group, P.O. Box 3707, Seattle, Washington 98124-2207. Copies may be inspected at the FAA, Transport Airplane Directorate, 1601 Lind Avenue, SW., Renton, Washington; or at the Office of the Federal Register, 800 North Capitol Street, NW., suite 700, Washington, DC.

(f) This amendment becomes effective on June 15, 1999.

Issued in Renton, Washington, on May 3, 1999.

Darrell M. Pederson,

Acting Manager, Transport Airplane Directorate, Aircraft Certification Service.

[FR Doc. 99-11616 Filed 5-10-99; 8:45 am]

BILLING CODE 4910-13-P

DEPARTMENT OF TRANSPORTATION

Federal Aviation Administration

14 CFR Part 39

[Docket No. 99-SW-09-AD; Amendment 39-11168; AD 99-10-15]

RIN 2120-AA64

Airworthiness Directives; Eurocopter France Model AS332L2

AGENCY: Federal Aviation Administration, DOT.

ACTION: Final rule; request for comments.

SUMMARY: This amendment adopts a new airworthiness directive (AD) that is applicable to AS332L2 helicopters. This action requires inspecting each main rotor head drag damper (damper) for a tear, crack, or bonding separation in the elastomer and, if necessary, replacing the damper with an airworthy damper. This amendment is prompted by a report of increased helicopter vibration in flight that was traced to the delamination of the elastomer on a damper. This condition, if not corrected, could result in failure of a damper and

subsequent loss of control of the helicopter.

DATES: Effective May 26, 1999.

Comments for inclusion in the Rules Docket must be received on or before July 12, 1999.

ADDRESSES: Submit comments in triplicate to the Federal Aviation Administration (FAA), Office of the Regional Counsel, Southwest Region, Attention: Rules Docket No. 99-SW-09-AD, 2601 Meacham Blvd, Room 663, Fort Worth, Texas. Comments may be inspected at this location between 9 a.m. and 3 p.m., Monday through Friday, except Federal holidays.

FOR FURTHER INFORMATION CONTACT: Mike Mathias, Aerospace Engineer, FAA, Rotorcraft Directorate, Rotorcraft Standards Staff, Fort Worth, Texas 76193-0111, telephone (817) 222-5123, fax (817) 222-5961.

SUPPLEMENTARY INFORMATION: The Direction Generale De L'Aviation Civile (DGAC), the airworthiness authority for France, has notified the FAA that an unsafe condition may exist on Eurocopter France Model AS332L2 helicopters. The DGAC advises that it has received a report of damper elastomer impending separation on this model helicopter.

This helicopter model is manufactured in France and is type certificated for operation in the United States under the provisions of § 21.29 of the Federal Aviation Regulations (14 CFR 21.29) and the applicable bilateral airworthiness agreement. Pursuant to this bilateral airworthiness agreement, the DGAC has kept the FAA informed of the situation described above. The FAA has examined the findings of the DGAC, reviewed all available information, and determined that AD action is necessary for products of this type design that are certificated for operation in the United States.

Since an unsafe condition has been identified that is likely to exist or develop on other Eurocopter France Model AS332L2 helicopters of the same type design registered in the United States, this AD is being issued to prevent failure of a damper. This AD requires inspecting each damper for a tear, crack, or bonding separation in the elastomer and, if necessary, replacing the damper with an airworthy damper.

None of the Model AS332L2 helicopters affected by this action are on the U.S. Register. All helicopters included in the applicability of this rule are operated by non-U.S. operators under foreign registry; therefore, they are not directly affected by this AD action. However, the FAA considers that this rule is necessary to ensure that the

unsafe condition is addressed in the event that any of these subject helicopters are imported and placed on the U.S. Register in the future.

Should an affected helicopter be imported and placed on the U.S. Register in the future, it would require approximately $\frac{2}{3}$ of a work hour to accomplish each of the inspections initially and to replace unairworthy parts at an average labor rate of \$60 per work hour. Required parts would be approximately \$4,000 per helicopter. Based on these figures, the total cost impact of the AD is estimated to be \$4,040 per helicopter.

Since this AD action does not affect any helicopter that is currently on the U.S. Register, it has no adverse economic impact and imposes no additional burden on any person. Therefore, notice and public procedures hereon are unnecessary and the amendment may be made effective in less than 30 days after publication in the **Federal Register**.

Comments Invited

Although this action is in the form of a final rule that involves requirements affecting flight safety and, thus, was not preceded by notice and an opportunity for public comment, comments are invited on this rule. Interested persons are invited to comment on this rule by submitting such written data, views, or arguments as they may desire. Communications should identify the Rules Docket number and be submitted in triplicate to the address specified under the caption "ADDRESSES." All communications received on or before the closing date for comments will be considered, and this rule may be amended in light of the comments received. Factual information that supports the commenter's ideas and suggestions is extremely helpful in evaluating the effectiveness of the AD action and determining whether additional rulemaking action would be needed.

Comments are specifically invited on the overall regulatory, economic, environmental, and energy aspects of the rule that might suggest a need to modify the rule. All comments submitted will be available, both before and after the closing date for comments, in the Rules Docket for examination by interested persons. A report that summarizes each FAA-public contact

concerned with the substance of this AD will be filed in the Rules Docket.

Commenters wishing the FAA to acknowledge receipt of their comments submitted in response to this rule must submit a self-addressed, stamped postcard on which the following statement is made: "Comments to Docket No. 99-SW-09-AD." The postcard will be date stamped and returned to the commenter.

The regulations adopted herein will not have substantial direct effects on the States, on the relationship between the national government and the States, or on the distribution of power and responsibilities among the various levels of government. Therefore, in accordance with Executive Order 12612, it is determined that this final rule does not have sufficient federalism implications to warrant the preparation of a Federalism Assessment.

The FAA has determined that notice and prior public comment are unnecessary in promulgating this regulation; and, therefore, it can be issued immediately to correct an unsafe condition in aircraft since none of these model helicopters are registered in the United States. It is not a "significant regulatory action" under Executive Order 12866. It has been determined further that this action involves an emergency regulation under DOT Regulatory Policies and Procedures (44 FR 11034, February 26, 1979). If it is determined that this emergency regulation otherwise would be significant under DOT Regulatory Policies and Procedures, a final regulatory evaluation will be prepared and placed in the Rules Docket. A copy of it, if filed, may be obtained from the Rules Docket at the location provided under the caption **ADDRESSES**.

List of Subjects in 14 CFR Part 39

Air transportation, Aircraft, Aviation safety, Safety.

Adoption of the Amendment

Accordingly, pursuant to the authority delegated to me by the Administrator, the Federal Aviation Administration amends part 39 of the Federal Aviation Regulations (14 CFR part 39) as follows:

PART 39—AIRWORTHINESS DIRECTIVES

1. The authority citation for part 39 continues to read as follows:

Authority: 49 U.S.C. 106(g), 40113, 44701.

§ 39.13 [Amended]

2. Section 39.13 is amended by adding a new airworthiness directive (AD) to read as follows:

AD 99-10-15 **Eurocopter France:**

Amendment 39-11168. Docket No. 99-SW-09-AD.

Applicability: AS332L2 helicopters, with main rotor head drag damper, part number (P/N) 332A311980-02, having elastomeric bearings P/N J19084-4, installed, certificated in any category.

Note 1: This AD applies to each helicopter identified in the preceding applicability provision, regardless of whether it has been otherwise modified, altered, or repaired in the area subject to the requirements of this AD. For helicopters that have been modified, altered, or repaired so that the performance of the requirements of this AD is affected, the owner/operator must request approval for an alternative method of compliance in accordance with paragraph (c) of this AD. The request should include an assessment of the effect of the modification, alteration, or repair on the unsafe condition addressed by this AD; and, if the unsafe condition has not been eliminated, the request should include specific proposed actions to address it.

Compliance: Required as indicated, unless accomplished previously.

To detect delamination of an elastomeric bearing that could result in failure of a main rotor head drag damper (damper) and subsequent loss of control of the helicopter, accomplish the following:

(a) Within 10 hours time-in-service (TIS), inspect each damper, P/N 332A311980-02, for a tear, crack, or bonding separation in the elastomer as follows: (See Figure 1.)

(1) Separate the elastomer in Area A (outside reinforcement) and in area B (inside reinforcement).

(2) If a tear, crack, or bonding separation is found, replace the damper with an airworthy damper.

Note 2: American Eurocopter Master Servicing Recommendation (PRE) 05.99.00, rush revision date-code 97-46, and the Aircraft Maintenance Manual Nos. 05.21.00.213 and 05.21.00.213.001 pertain to the subject of this AD.

(b) Thereafter, prior to the first flight of each day or at intervals not to exceed 20 hours TIS, whichever occurs first, perform the inspection in paragraph (a). If a tear, crack, or bonding separation is found in the elastomer, replace the damper with an airworthy damper.

BILLING CODE 4910-13-U

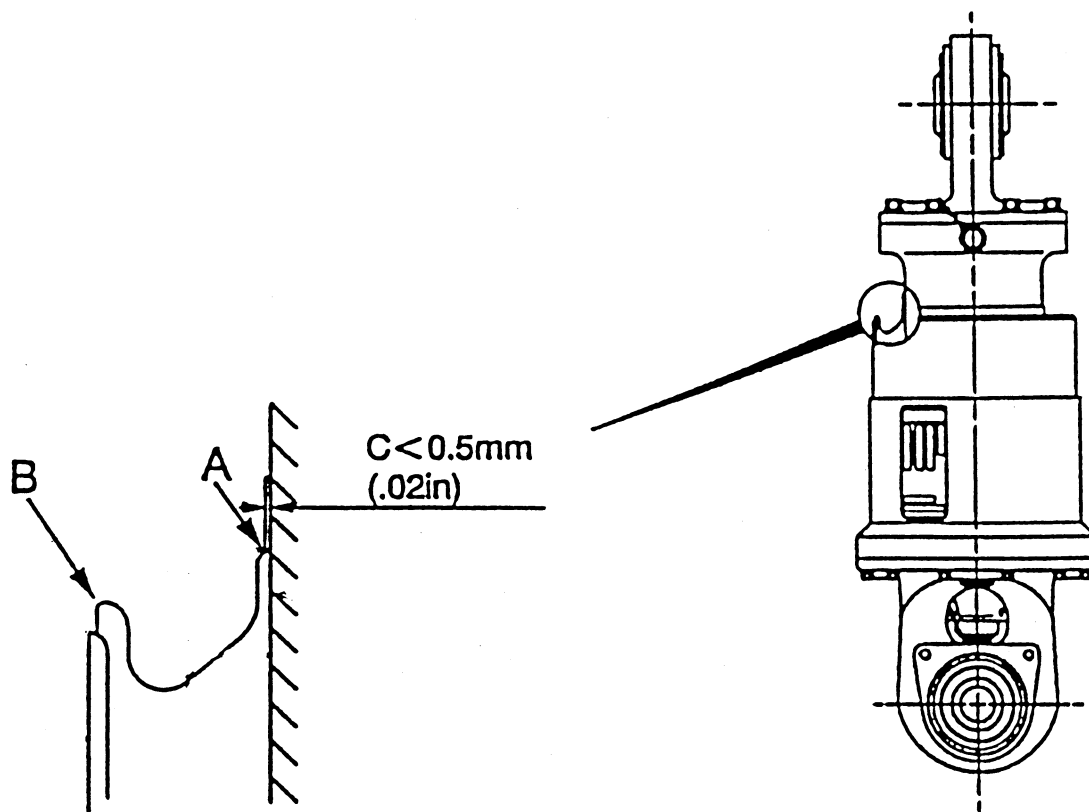

Figure 1

BILLING CODE 4910-13-C

(c) An alternative method of compliance or adjustment of the compliance time that provides an acceptable level of safety may be used if approved by the Manager, Rotorcraft Standards Staff. Operators shall submit their requests through an FAA Principal Maintenance Inspector who may concur or comment and then send it to the Manager, Rotorcraft Standards Staff.

Note 3: Information concerning the existence of approved alternative methods of compliance with this AD, if any, may be obtained from the Rotorcraft Standards Staff.

(d) Special flight permits may be issued in accordance with §§ 21.197 and 21.199 of the Federal Aviation Regulations (14 CFR 21.197 and 21.199) to operate the helicopter to a location where the requirements of this AD can be accomplished.

(e) This amendment becomes effective on May 26, 1999.

Note 4: The subject of this AD is addressed in Direction Generale De L'Aviation Civile (France) AD 97-378-009(AB), dated December 17, 1997.

Issued in Fort Worth, Texas, on May 4, 1999.

Henry A. Armstrong,

Manager, Rotorcraft Directorate, Aircraft Certification Service.

[FR Doc. 99-11781 Filed 5-10-99; 8:45 am]

BILLING CODE 4910-13-U

DEPARTMENT OF TRANSPORTATION

Federal Aviation Administration

14 CFR Part 39

[Docket No. 99-CE-03-AD; Amendment 39-11081; AD 99-06-17]

RIN 2120-AA64

Airworthiness Directives; Pilatus Aircraft Ltd. Models PC-12 and PC-12/45 Airplanes

AGENCY: Federal Aviation Administration, DOT.

ACTION: Direct final rule; confirmation of effective date.

SUMMARY: This action confirms the effective date of Airworthiness Directive

(AD) 99-06-17, which applies to certain Pilatus Aircraft Ltd. (Pilatus) Models PC-12 and PC-12/45 airplanes. AD 99-06-17 requires installing a support bracket and a cut-out relay for the second generator control unit. AD 99-06-17 also requires making all the wiring additions and adjustments necessary for the above-referenced installations. This AD was the result of mandatory continuing airworthiness information (MCAI) issued by the airworthiness authority for Switzerland. The actions specified in this AD are intended to prevent damage to electrical components because incorrectly connected cables or broken or damaged wires cause excessive voltages to the second generator, which could result in loss of electrical power during any phase of flight.

EFFECTIVE DATE: June 16, 1999.

FOR FURTHER INFORMATION CONTACT: Mr. Roman T. Gabrys, Aerospace Engineer, FAA, Small Airplane Directorate, 1201 Walnut, suite 900, Kansas City, Missouri 64106; telephone: (816) 426-6932; facsimile: (816) 426-2169.