

DEPARTMENT OF TRANSPORTATION**National Highway Traffic Safety Administration****49 CFR Part 572**

[Docket No. NHTSA-99-5156]

RIN 2127-AG78

Anthropomorphic Test Dummy; Occupant Crash Protection

AGENCY: National Highway Traffic Safety Administration (NHTSA), Department of Transportation.

ACTION: Notice of proposed rulemaking.

SUMMARY: This document proposes to adopt design and performance specifications for a new 12-month-old infant dummy. The new dummy is especially needed to evaluate the effects of air bag deployment on children who are not properly positioned at the time of a crash, i.e., out-of-position. It would also provide greater and more useful information in a variety of crash environments to better evaluate child safety. Adopting the dummy would be the first step toward using it to evaluate the safety of air bags for infants and very young children. The separate issue of specifying use of the dummy in determining compliance with performance tests, e.g., as part of the occupant protection standard and/or child restraint standard, will be addressed in other rulemakings, most notably the proposed advanced air bag rulemaking.

DATES: You should submit your comments early enough to ensure that Docket Management receives them not later than April 22, 1999.

ADDRESSES: You should mention the docket number of this document in your comments and submit your comments in writing to: Docket Management, Room PL-401, 400 Seventh Street, S.W., Washington, D.C., 20590.

You may call the Docket at 202-366-9324. You may visit the Docket from 10:00 a.m. to 5:00 p.m., Monday through Friday.

FOR FURTHER INFORMATION CONTACT: For non-legal issues, you may call Stan Backaitis, Office of Crashworthiness Standards, at 202-366-4912.

For legal issues, you may call Rebecca MacPherson, Office of the Chief Counsel, at 202-366-2992.

You may send mail to both of these officials at National Highway Traffic Safety Administration, 400 Seventh St., S.W., Washington, D.C., 20590.

SUPPLEMENTARY INFORMATION: Air bag fatalities of children have raised serious concerns about how best to evaluate

their safety in a variety of crash environments. We are working with the automotive industry to assure greater safety in motor vehicles through the development, evaluation and application of significantly improved occupant protection technologies. As part of our overall program to achieve greater safety, we are developing new and improved test devices to evaluate the relationship between observed injuries and the forces causing them. One of the new test devices is a 12-month-old infant dummy.

In 1990 the Society of Automotive Engineers (SAE) began the development of a 12-month-old infant dummy designed to evaluate a very young child's interaction with an air bag. At that time, the SAE Child Restraint Air Bag Interaction (CRABI) Task Force requested the SAE Mechanical Human Simulation Subcommittee to address the need for a new infant dummy that could be used in testing and evaluating the effects of child restraints and air bags, as well as their interaction, on infants. The CRABI Task Force had determined that the biofidelity and impact response of the existing infant dummies were inadequate and that those dummies were not suitable for modification or retrofit. In view of the deficiencies in those dummies, the task force concluded that an entirely new dummy was needed. The new dummy was to be capable of evaluating both rear facing and forward facing child restraints, as well as the injury potential of air bags for out-of-position children.

The SAE subsequently developed the CRABI 12-month-old infant dummy. Our initial review of the results of tests with the dummy in 1996 indicated serious structural and performance deficiencies that prevented it from being a stable and objective test device. We addressed these problems cooperatively with SAE Hybrid III Dummy Family Task Group. These efforts produced a substantially modified dummy. Some changes were made as late as September 1998.

The dummy's initial configuration and biomechanical response corridors were based on anthropometry and mass distribution of 3-year-old children and on scaling techniques from the 50th percentile male Hybrid III dummy. The scaling reflects differences in geometry and dimensional characteristics of particular body segments and their elastic properties. The dummy's biofidelity response corridors cover head impact response in drop tests and neck flexion in pendulum tests.

Since we could not determine the stiffness of the ribcage and abdomen based on existing biofidelity data, we

asked a medical advisory group at the Children's National Medical Center in Washington, D.C. to evaluate the dummy based on its expertise with children of that age group. Changes were made to the stiffness of the dummy's ribcage as a result of the physicians' evaluation and recommendation. The stiffness of the dummy's abdomen was deemed to appropriately mimic that of an actual child.

While the CRABI Task Force had recommended that the dummy be tested while dressed in a diaper and standard clothing during tests, we have not conducted any tests with a diapered dummy. We have decided against using diapers because we believe diapers would prevent the dummy from producing repeatable results.

Based on our evaluation of the latest version of the CRABI 12-month-old infant crash test dummy through a new, rigorous test program, we have tentatively concluded that the dummy is ready for incorporation into Part 572. As a result of our evaluation and the dummy's intended use in forward and rear facing child restraints, we are proposing calibration specifications for the head and neck both in frontal and rear impacts. We are also proposing calibration specifications for a frontal impact test that measures thorax responses and a torso flexion stiffness test. We are placing in the docket a technical report entitled "Development and Evaluation of the CRABI 12-Month-Old Infant Crash Test Dummy (January, 1999 version)." That report provides the technical information supporting this rulemaking.

The proposed specifications and performance criteria for the CRABI 12-month-old infant crash test dummy would consist of two items:

- (1) A drawings and specifications package entitled "Parts List and Drawings and for the 12-Month-Old Infant (CRABI) Dummy (January 1999)"; and
- (2) A user's manual entitled "User's Manual for the CRABI 12-Month-Old Infant Dummy [a date would be inserted in the final rule]."

In order to facilitate comment on the general content and format of the user's manual, we have placed in the docket a copy of a manual entitled "User's Guide for the Twelve and Eighteen Month Old Infant Dummies (CRABI)", SAE Engineering Aid 27 (June 1995).

The specifications are intended to ensure that the dummies are uniform in their construction and capable of repeatable and reproducible response in the impact environment. We note that the first item listed above, the parts list

and drawings, is available for inspection in our technical reference library. (Since this item is non-scannable, we cannot place it in the DOT Dockets Management System (DMS). Instead, we have placed in the docket a statement indicating where this item may be viewed, i.e., in NHTSA's technical reference library. You may also obtain copies from Reprographic Technologies, 9000 Virginia Manor Road, Beltsville, MD 20705; Telephone: (301) 419-5070.

As we have done for other dummies, we are proposing impact performance criteria to serve as calibration checks, and to further assure the kinematic uniformity of the dummy and the absence of structural damage and functional deficiency from previous use. The tests address head, neck, and thorax impact responses and resistance to flexion motion assessments of the lumbar spine-abdomen area when the upper torso half is flexed relative to the lower half.

We are proposing generic specifications for all of the dummy-based sensors. For most earlier dummies, we specified sensors by make and model. However, we believe that approach is unnecessarily restrictive and limits innovation and competition.

The proposed sensor specifications are essentially generic and reflect performance characteristics of the sensors used in our dummy evaluation series that are identified by make and model in the above referenced technical report "Development and Evaluation of the CRABI 12-month-old Infant Dummy." Specifications for the proposed sensors are included in the drawing package. You are encouraged to comment on the adequacy of the proposed specifications; the potential impact on the quality of measurements to be acquired, including the comparability of data using sensors manufactured by different companies; and issues related to calibration assurance tests.

We note that the CRABI 12-month-old infant dummy is the fourth of several new dummies we are proposing to add to Part 572. We have already proposed adding a new, advanced 6-year-old dummy (H-III6C) (63 FR 35170), a fifth percentile small adult female dummy (H-III5F) (63 FR 46981), and an advanced 3-year-old dummy (H-III3C) (64 FR 4385). We intend to use these dummies in connection with our rulemaking for advanced air bags (NRPM at 63 FR 49958). As part of that rulemaking, we could specify all of these dummies for use in a variety of potential Standard No. 208 tests, including static out-of-position tests and/or various dynamic tests. In a

separate rulemaking, we could consider specifying these child dummies for use in Standard No. 213 tests.

We emphasize, however, that this notice only concerns the CRABI 12-month-old dummy, and that we are only proposing to add the dummy to Part 572. However, since one of the primary purposes of adding the dummy to Part 572 is to enable it to be specified for use in the Federal motor vehicle safety standards, we encourage you to address its suitability for tests related to occupant crash protection, e.g., those discussed or proposed in the NPRM on advanced air bags. We also encourage you to address the dummy's suitability with respect to measuring proposed and other injury criteria,¹ as well as the choice of and potential impact of traditional clothing on the dummy and its calibration measurements.

Regulatory Analyses and Notices

Executive Order 12866 and DOT Regulatory Policies and Procedures

Executive Order 12866, "Regulatory Planning and Review" (58 FR 51735, October 4, 1993), provides for making determinations whether a regulatory action is "significant" and therefore subject to Office of Management and Budget (OMB) review and to the requirements of the Executive Order. The Order defines a "significant regulatory action" as one that is likely to result in a rule that may:

- (1) Have an annual effect on the economy of \$100 million or more or adversely affect in a material way the economy, a sector of the economy, productivity, competition, jobs, the environment, public health or safety, or State, local, or Tribal governments or communities;
- (2) Create a serious inconsistency or otherwise interfere with an action taken or planned by another agency;
- (3) Materially alter the budgetary impact of entitlements, grants, user fees, or loan programs or the rights and obligations of recipients thereof; or
- (4) Raise novel legal or policy issues arising out of legal mandates, the President's priorities, or the principles set forth in the Executive Order.

We have considered the impact of this rulemaking action under Executive Order 12866 and the Department of Transportation's regulatory policies and procedures. This rule is not considered a significant regulatory action under

¹ For information concerning potential injury criteria, see *Development of Improved Injury Criteria for the Assessment of Advanced Automotive Restraint Systems*, June, 1998, Docket No. NHTSA98-4405-9. (Available on the NHTSA website at <http://www.nhtsa.dot.gov>.)

section 3(f) of the Executive Order 12866. Consequently, it was not reviewed by the Office of Management and Budget. This rulemaking document was not reviewed by the Office of Management and Budget under E.O. 12866, "Regulatory Planning and Review." The rulemaking action is also not considered to be significant under the Department's Regulatory Policies and Procedures (44 FR 11034; February 26, 1979).

This document proposes to amend 49 CFR Part 572 by adding design and performance specifications for a new 12-month-old child dummy which the agency may later separately propose for use in the Federal motor vehicle safety standards. If this proposed rule becomes final, it would impose requirement on only those businesses which choose to manufacture or test with the dummy. It may indirectly affect vehicle and child seat manufacturers if it is incorporated by reference into the advanced air bag rulemaking or a future Child Seating Systems (FMVSS No. 213) rulemaking.

The cost of an uninstrumented CRABI dummy is approximately \$17,000. Instrumentation would add approximately \$14,000 to the cost, depending on the amount of data channels the user chooses to collect.

Because the economic impacts of this proposal are so minimal, no further regulatory evaluation is necessary.

Executive Order 12612

We have analyzed this proposal in accordance with Executive Order 12612 ("Federalism"). We have determined that this proposal does not have sufficient Federalism impacts to warrant the preparation of a federalism assessment.

Executive Order 13045

Executive Order 13045 (62 FR 19885, April 23, 1997) applies to any rule that: (1) is determined to be "economically significant" as defined under E.O. 12866, and (2) concerns an environmental, health or safety risk that NHTSA has reason to believe may have a disproportionate effect on children. If the regulatory action meets both criteria, we must evaluate the environmental health or safety effects of the planned rule on children, and explain why the planned regulation is preferable to other potentially effective and reasonably feasible alternatives considered by us.

This rule is not subject to the Executive Order because it is not economically significant as defined in E.O. 12866. It does indirectly involve decisions based on health risks that disproportionately affect children, namely, the risk of deploying air bags to

infants. However, this rulemaking serves to reduce, rather than increase, that risk.

Executive Order 12778

Pursuant to Executive Order 12778, "Civil Justice Reform," we have considered whether this proposed rule would have any retroactive effect. We conclude that it would not have such effect. Under 49 U.S.C. 30103, whenever a Federal motor vehicle safety standard is in effect, a State may not adopt or maintain a safety standard applicable to the same aspect of performance which is not identical to the Federal standard, except to the extent that the state requirement imposes a higher level of performance and applies only to vehicles procured for the State's use. 49 U.S.C. 30161 sets forth a procedure for judicial review of final rules establishing, amending or revoking Federal motor vehicle safety standards. That section does not require submission of a petition for reconsideration or other administrative proceedings before parties may file suit in court.

Regulatory Flexibility Act

Pursuant to the Regulatory Flexibility Act (5 U.S.C. 601 *et seq.*, as amended by the Small Business Regulatory Enforcement Fairness Act (SBREFA) of 1996) whenever an agency is required to publish a notice of rulemaking for any proposed or final rule, it must prepare and make available for public comment a regulatory flexibility analysis that describes the effect of the rule on small entities (i.e., small businesses, small organizations, and small governmental jurisdictions). However, no regulatory flexibility analysis is required if the head of an agency certifies the rule will not have a significant economic impact on a substantial number of small entities. SBREFA amended the Regulatory Flexibility Act to require Federal agencies to provide a statement of the factual basis for certifying that a rule will not have a significant economic impact on a substantial number of small entities.

The Administrator has considered the effects of this rulemaking action under the Regulatory Flexibility Act (5 U.S.C. 601 *et seq.*) and certifies that this proposal would not have a significant economic impact on a substantial number of small entities. The proposal would not impose or rescind any requirements for anyone. The Regulatory Flexibility Act does not, therefore, require a regulatory flexibility analysis.

National Environmental Policy Act

We have analyzed this proposed amendment for the purposes of the National Environmental Policy Act and determined that it would not have any significant impact on the quality of the human environment.

Paperwork Reduction Act

Under the Paperwork Reduction Act of 1995, a person is not required to respond to a collection of information by a Federal agency unless the collection displays a valid OMB control number. This proposal does not propose any new information collection requirements.

National Technology Transfer and Advancement Act

Section 12(d) of the National Technology Transfer and Advancement Act of 1995 (NTTAA), Public Law 104-113, section 12(d) (15 U.S.C. 272) directs us to use voluntary consensus standards in its regulatory activities unless doing so would be inconsistent with applicable law or otherwise impractical. Voluntary consensus standards are technical standards (e.g., materials specifications, test methods, sampling procedures, and business practices) that are developed or adopted by voluntary consensus standards bodies, such as the Society of Automotive Engineers (SAE). The NTTAA directs us to provide Congress, through OMB, explanations when we decide not to use available and applicable voluntary consensus standards.

The CRABI twelve-month-old dummy that is the subject of this document was developed under the auspices of the SAE. All relevant SAE standards were reviewed as part of the development process. The following voluntary consensus standards have been used in developing the dummy:

- SAE Recommended Practice J211, Rev. Mar95 "Instrumentation for Impact Tests";
- SAE J1733 of 1994-12 "Sign Convention for Vehicle Crash Testing".

Unfunded Mandates Reform Act

Section 202 of the Unfunded Mandates Reform Act of 1995 (UMRA) requires Federal agencies to prepare a written assessment of the costs, benefits and other effects of proposed or final rules that include a Federal mandate likely to result in the expenditure by State, local or tribal governments, in the aggregate, or by the private sector, of more than \$100 million in any one year (adjusted for inflation with base year of 1995). Before promulgating a NHTSA rule for which a written statement is

needed, section 205 of the UMRA generally requires us to identify and consider a reasonable number of regulatory alternatives and adopt the least costly, most cost-effective or least burdensome alternative that achieves the objectives of the rule. The provisions of section 205 do not apply when they are inconsistent with applicable law. Moreover, section 205 allows us to adopt an alternative other than the least costly, most cost-effective or least burdensome alternative if we publish with the final rule an explanation why that alternative was not adopted.

This proposal does not propose to impose any unfunded mandates under the Unfunded Mandates Reform Act of 1995. This proposal does not meet the definition of a Federal mandate because it does not impose requirements on anyone. Further, it would not result in costs of \$100 million or more to either State, local, or tribal governments, in the aggregate, or to the private sector. Thus, this proposal is not subject to the requirements of sections 202 and 205 of the UMRA.

Regulation Identifier Number (RIN)

The Department of Transportation assigns a regulation identifier number (RIN) to each regulatory action listed in the Unified Agenda of Federal Regulations. The Regulatory Information Service Center publishes the Unified Agenda in April and October of each year. You may use the RIN contained in the heading at the beginning of this document to find this action in the Unified Agenda.

Comments

How do I prepare and submit comments?

Your comments must be written and in English. To ensure that your comments are correctly filed in the Docket, please include the docket number of this document in your comments.

Your comments must not be more than 15 pages long. (49 CFR 553.21). We established this limit to encourage you to write your primary comments in a concise fashion. However, you may attach necessary additional documents to your comments. There is no limit on the length of the attachments.

Please submit two copies of your comments, including the attachments, to Docket Management at the address given above under **ADDRESSES**.

How can I be sure that my comments were received?

If you wish Docket Management to notify you upon its receipt of your comments, enclose a self-addressed,

stamped postcard in the envelope containing your comments. Upon receiving your comments, Docket Management will return the postcard by mail.

How do I submit confidential business information?

If you wish to submit any information under a claim of confidentiality, you should submit three copies of your complete submission, including the information you claim to be confidential business information, to the Chief Counsel, NHTSA, at the address given above under **FOR FURTHER INFORMATION CONTACT**. In addition, you should submit two copies, from which you have deleted the claimed confidential business information, to Docket Management at the address given above under **ADDRESSES**. When you send a comment containing information claimed to be confidential business information, you should include a cover letter setting forth the information specified in our confidential business information regulation. (49 CFR Part 512.)

Will the agency consider late comments?

We will consider all comments that Docket Management receives before the close of business on the comment closing date indicated above under **DATES**. To the extent possible, we will also consider comments that Docket Management receives after that date. If Docket Management receives a comment too late for us to consider it in developing a final rule (assuming that one is issued), we will consider that comment as an informal suggestion for future rulemaking action.

How can I read the comments submitted by other people?

You may read the comments received by Docket Management at the address given above under **ADDRESSES**. The hours of the Docket are indicated above in the same location.

You may also see the comments on the Internet. To read the comments on the Internet, take the following steps:

1. Go to the Docket Management System (DMS) Web page of the Department of Transportation (<http://dms.dot.gov/>).
2. On that page, click on "search."
3. On the next page (<http://dms.dot.gov/search/>), type in the four-digit docket number shown at the beginning of this document. Example: If the docket number were "NHTSA-1998-1234," you would type "1234." After typing the docket number, click on "search."
4. On the next page, which contains docket summary information for the docket you selected, click on the desired

comments. You may download the comments. However, since the comments are imaged documents, instead of word processing documents, the downloaded comments are not word searchable.

Please note that even after the comment closing date, we will continue to file relevant information in the Docket as it becomes available. Further, some people may submit late comments. Accordingly, we recommend that you periodically check the Docket for new material.

List of Subjects in 49 CFR Part 572

Motor vehicle safety.

In consideration of the foregoing, NHTSA proposes to amend 49 CFR Part 572 as follows:

PART 572—ANTHROPOMORPHIC TEST DUMMIES

1. The authority citation for Part 572 would continue to read as follows:

Authority: 49 U.S.C. 332, 30111, 30115, 30117; and 30166 delegation of authority at 49 CFR 1.50.

2. 49 CFR Part 572 would be amended by adding a new Subpart R consisting of 572.150–572.156 to read as follows:

Subpart R—CRABI 12-Month-Old-Infant Crash Test Dummy

- Sec.
- 572.150 Incorporation by reference.
 - 572.151 General description.
 - 572.152 Head assembly and test procedure.
 - 572.153 Neck-headform assembly and test procedure.
 - 572.154 Thorax assembly and test procedure.
 - 572.155 Torso assembly and torso flexion test procedure.
 - 572.156 Test condition and instrumentation.

Subpart R—CRABI 12-Month-Old-Infant Crash Test Dummy

§ 572.150 Incorporation by reference.

(a) The following materials are hereby incorporated in this subpart R by reference.

- (1) A drawings and specifications package entitled "Parts List and Drawings for the CRABI 12-Month-Old-Infant Crash Test Dummy (January 1999)";
 - (2) A user's manual entitled "User's Manual for the CRABI 12-Month-Old-Infant Crash Test Dummy [a date will be inserted in the final rule]";
 - (3) SAE Recommended Practice J211, Rev. Mar95 "Instrumentation for Impact Tests";
 - (4) SAE J1733 of 1994-12 "Sign Convention for Vehicle Crash Testing".
- (b) The Director of the Federal Register approved those materials

incorporated by reference in accordance with 5 U.S.C. 552(a) and 1 CFR part 51. Copies of the materials may be inspected at NHTSA's Docket Section, 400 Seventh Street S.W., room 5109, Washington, DC, or at the Office of the Federal Register, 800 North Capitol Street, NW, Suite 700, Washington, DC.

(c) The incorporated materials are available as follows:

- (1) The drawings and specifications package referred to in paragraph (a)(1) of this section and the user's manual referred to in paragraph (a)(2) of this section are available from Reprographic Technologies, 9000 Virginia Manor Road, Beltsville, MD 20705 (301) 419-5070.
- (2) The SAE materials referred to paragraphs (a)(3) and (a)(4) of this section are available from the Society of Automotive Engineers, Inc., 400 Commonwealth Drive, Warrendale, PA 15096.

§ 572.151 General description.

(a) The representative 12 Month-Old-Infant crash test dummy is described by the following materials:

- (1) Technical drawings and specifications package 921022-000, the titles of which are listed in Table A;
- (2) Operation and Maintenance Manual (to be incorporated at issuance of final rule);
- (b) The dummy is made up of the component assemblies set out in the following Table A:

TABLE A

Component assembly	Drawing number
Head Assembly	921022-001
Neck Assembly (complete)	921022-041
Upper/Lower Torso Assembly.	921022-060
Leg Assembly	921022-055 R&L
Arm Assembly	921022-054 R&L

(c) Adjacent segments of the dummy are joined in a manner such that, except for contacts existing under static conditions, there is no contact between metallic elements throughout the range of motion or under simulated crash impact conditions.

(d) The structural properties of the dummy are such that the dummy conforms to this part in every respect before its use in any test similar to those specified in Standard Nos. 208, Occupant Crash Protection, and 213, Child Restraint Systems.

§ 572.152 Head assembly and test procedure.

(a) The head assembly for this test consists of the assembly (drawing

921022-001), triaxial mount block (SA572-80), and 3 accelerometers (drawing SA572-S4).

(b) Frontal and rear impact.

(1) Frontal impact. When the head assembly in paragraph (a) of this section is dropped from a height of 376.0+/- 1.0 mm (14.8+/- 0.04 in) in accordance with paragraph (c)(3)(i) of this section, the peak resultant acceleration at the location of the accelerometers at the head CG shall not be less than 100 g or more than 120 g. The resultant acceleration vs. time history curve shall be unimodal, and the oscillations occurring after the main pulse shall be less than 10 percent of the peak resultant acceleration. The lateral acceleration shall not exceed +/- 15 g's.

(2) Rear impact. When the head assembly in paragraph (a) of this section is dropped from a height of 376.0+/- 1.0 mm (14.8+/- 0.04 in) in accordance with paragraph (c)(3)(ii) of this section, the peak resultant acceleration at the location of the accelerometers at the head CG shall not be less than 55 g and more than 71 g. The resultant acceleration vs. time history curve shall be unimodal, and the oscillations occurring after the main pulse shall be less than 10 percent of the peak resultant acceleration. The lateral acceleration shall not exceed +/- 15 g's.

(c) Head test procedure. The test procedure for the head is as follows:

(1) Soak the head assembly in a controlled environment at any temperature between 18.9 and 25.6 °C (66 and 78 °F) and at any relative humidity between 10 and 70 percent for at least four hours prior to a test. These temperature and humidity levels shall be maintained throughout the entire testing period specified in this section.

(2) Prior to the test, clean the impact surface of the head skin and the steel impact plate surface with isopropyl alcohol, trichlorethane, or an equivalent. Both impact surfaces must be clean and dry for testing.

(3)(i) Suspend the head assembly with its midsagittal plane in vertical orientation as shown in Figure R1. The lowest point on the forehead is 376.0+/- 1.0 mm (14.8+/- 0.04 in) from the steel impact surface. The 1.57 mm (0.062 in) diameter holes located on either side of the dummy's head in transverse alignment with the CG, are used to ensure that the head transverse plane is level with respect to the impact surface. The angle between the lower surface plane of the neck transducer mass simulator (drawing 910420-003) and the plane of the impact surface is 45+/- 1 degrees.

(ii) Suspend the head assembly with its midsagittal plane in vertical orientation as shown in Figure R2. The lowest point on the back of the head is 376.0+/- 1.0 mm (14.8+/- 0.04 in) from the steel impact surface. The 1.57 mm (0.062 in) diameter holes located on either side of the dummy's head in transverse alignment with the CG are used to ensure that the head transverse plane is level with respect to the impact surface. The angle between the lower surface plane of the neck transducer mass simulator (drawing 910420-003) and the impact surface is 90+/- 1 degrees.

(4) Drop the head assembly from the specified height by a means that ensures a smooth, instant release onto a rigidly supported flat horizontal steel plate which is 51 mm (2 in) thick and 610 mm (24 in) square. The impact surface shall have a finish of not less than 0.2 microns (8 micro inches) (RMS) and not more than 2 microns (80 micro inches) (RMS).

(5) Allow at least 2 hours between successive tests on the same head.

§ 572.153 Neck-headform assembly and test procedure.

(a) The neck and headform assembly for the purposes of this test consists of the neck assembly (drawing 921022-041), adapter assembly (drawing TE3200-160), force-moment transducer (drawing SA572-S23), and headform assembly (drawing TE3200-140).

(b) When the neck and headform assembly, as defined in § 572.153(a), is tested according to the test procedure in § 572.153(c), it shall have the following characteristics:

(1) Flexion.

(i) Plane D referenced in Figure R3 shall rotate in the direction of pre-impact flight with respect to the pendulum's longitudinal centerline not less than 75 degrees and not more than 89 degrees between 42 milliseconds (ms) and 56 ms after time zero.

(ii) The peak moment measured by the neck transducer (drawing SA572-S23) about the occipital condyles shall have a value not less than 37 Nm (27.3 ft-lb) and not more than 45 Nm (33.2 ft-lb) within the minimum and maximum rotation interval. The positive moment shall decay for the first time to 5 Nm (3.7 ft-lb) between 60 ms and 80 ms.

(2) Extension.

(i) Plane D referenced in Figure R4 shall rotate in the direction of preimpact flight with respect to the pendulum's longitudinal centerline not less than 78 degrees and not more than 90 degrees between 58 ms and 66 ms after time zero.

(ii) The peak negative moment measured by the neck transducer (drawing SA572-S23) about the occipital condyles shall have a value not more than -11 Nm (-8.1 ft-lb) and not less than -23 Nm (-17.0 ft-lb) within the minimum and maximum rotation interval. The negative moment shall decay for the first time to -5 Nm (-3.7 ft-lb) between 78 ms and 90 ms after time zero.

(3) Time-zero is defined as the time of initial contact between the pendulum striker plate and the honeycomb material.

(c) Test Procedure.

(1) Soak the neck assembly in a controlled environment at any temperature between 20.6 and 22.2 °C (69 and 72 °F) and at any relative humidity between 10 and 70 percent for at least four hours prior to a test. These temperature and humidity levels shall be maintained throughout the entire testing period specified in this section.

(2) Torque the jam nut (drawing 9001336) on the neck cable (drawing ATD-6206) to 0.2 to 0.3 Nm (1.9-2.4 in-lb).

(3) Mount the neck-headform assembly, defined in paragraph (b) of this section, on the pendulum so the midsagittal plane of the headform is vertical and coincides with the plane of motion of the pendulum as shown in Figure R3 for flexion and Figure R4 for extension tests.

(i) The moment and rotation data channels are defined to be zero when the longitudinal centerline of the neck and pendulum are parallel.

(ii) The test shall be conducted without inducing any torsion type twisting of the neck.

(4) Release the pendulum and allow it to fall freely to achieve an impact velocity of 5.2+/- 0.1 m/s (17.1+/- 0.4 ft/s) for flexion and 2.5+/- 0.1 m/s (8.2+/- 0.4 ft/s) for extension measured at the center of the pendulum accelerometer at the instant of contact with the honeycomb.

(i) Time-zero is defined as the time of initial contact between the pendulum striker plate and the honeycomb material. The pendulum data channel should be at the zero level at this time.

(ii) Stop the pendulum from the initial velocity with an acceleration vs. time pulse which meets the velocity change as specified below. Integrate the pendulum acceleration data channel to obtain the velocity vs. time curve as indicated in Table B:

TABLE B.—PENDULUM PULSE

Time ms	Flexion		Time ms	Extension	
	m/s	ft/s		m/s	ft/s
10	1.6–2.3	5.2–7.5	6	0.8–1.2	2.6–3.9
20	3.4–4.2	11.2–13.8	10	1.5–2.1	4.9–6.9
25	4.3–5.2	14.1–17.1	14	2.2–2.9	7.2–9.5

§ 572.154 Thorax assembly and test procedure.

(a) Thorax Assembly. The thorax consists of the part of the torso assembly shown in drawing 921022–060.

(b) When the thorax of a completely assembled dummy (drawing 921022–000) is impacted by a test probe conforming to § 572.156(a) at 5.0+/-0.1m/s (16.5+/-0.3 ft/s) according to the test procedure in paragraph (c) of this section, the peak force, measured by the impact probe in accordance with paragraph § 572.156(a), shall be not less than 1600 N (360 lb) and not more than 1700 N (382 lb).

(c) Test procedure.

(1) Soak the dummy in a controlled environment at any temperature between 20.6 and 22.2°C (69 and 72 F) and at any relative humidity between 10 and 70 percent for at least four hours prior to a test. These temperature and humidity levels shall be maintained throughout the entire testing period specified in this section.

(2) Dress the dummy in light-weight cotton stretch short-sleeve shirt and above-the-knee pants.

(3) Seat and orient the dummy on a level seating surface without back support as shown in Figure R5, with the lower limbs extended forward, parallel to the midsagittal, plane and the arms slightly forward of vertical with fingers barely touching the seating surface plane. The dummy's midsagittal plane is vertical within +/- 1 degree and the posterior surface of the upper spine box is aligned at 90+/- 1 degrees from the horizontal. (Shim material may be used under the upper legs to maintain the dummy's specified spine box surface alignment).

(4) Establish the impact point at the chest midsagittal plane so that the impact point of the longitudinal centerline of the probe coincides with the dummy's mid-sagittal plane and is centered on the torso 196+/- 2.5 mm (7.7+/- 0.1 in) vertically from the plane of the seating surface and is within 0.5 degrees of a horizontal plane.

(5) Impact the thorax with the test probe so that at the moment of contact the probe's longitudinal center line falls within 2 degrees of a horizontal line in the dummy's midsagittal plane.

(6) Guide the test probe during impact so that there is no significant lateral, vertical or rotational movement.

(7) Allow at least 30 minutes between successive tests.

§ 572.155 Torso assembly and torso flexion test procedure.

(a) Torso assembly. The torso assembly consists of the upper and lower halves as shown in drawing 921022–060. The test objective is to determine the flexion stiffness of lumbar spine and abdomen of a fully assembled dummy to flexion articulation between upper and lower halves of the torso assembly.

(b) When the upper half of the torso assembly of a seated dummy is subjected to a force continuously applied at the occipital condyle level through a rigidly attached adaptor bracket as shown in Figure R6 according to the test procedure set out in paragraph (c) of this section, the lumbar spine-abdomen assembly shall:

(1) Flex by an amount that permits the thorax spine box (drawing 921022–031) to rotate in midsagittal plane with respect to the rigidly affixed pelvic structure weldment (drawing 921022–035) from the initial spine box position to 45 degrees from the vertical, at which time the force level is not less than 90 N (20 lb) and not more than 120 N (27 lb), and

(2) Upon removal of the force, the upper torso assembly returns to within 10 degrees of its initial position.

(c) Test procedure. The procedure for the upper/lower torso flexion stiffness test is as follows:

(1) Soak the dummy in a controlled environment at any temperature between 20.6° and 22.2°C (69 and 72 F) and at any relative humidity between 10 and 70 percent for at least 4 hours prior to a test. These temperature and humidity levels shall be maintained throughout the entire testing period specified in this section.

(2) Assemble the complete dummy and attach to the fixture in a seated posture as shown in Figure R6.

(i) Secure the pelvis to the fixture at the lumbar load transducer or its structural replacement with a rigid bracket as shown in Figure R6.

(ii) Tighten the mountings so that the pelvis-lumbar joining surface is horizontal within ±1 deg.

(3) Install a low weight rigid loading adapter bracket (not to exceed 0.50 kg (1.1 lb)) to the posterior of the thoracic spine at the rear surface of the upper instrumentation cavity box as shown in Figure R6. The loading bracket is designed such that the point of load application coincides with the longitudinal axis of the occipital condyle and also provides means for measuring the rotation of the upper torso.

(4) Flex the elbow joints to 90 degrees and point the lower arms forward.

(5) Inspect and adjust, if necessary, the positioning of the abdominal insert within the pelvis cavity and with respect to the torso flesh to assure uniform fit and clearances.

(6) Attach means of loading the dummy through the point of load application as shown in Figure R6.

(7) The initial orientation of the angle reference plane of the seated, unsupported dummy shall not exceed 20 degrees of flexion as shown in Figure R6. The angle reference plane is defined by the transverse plane the rear surface of the upper thoracic instrumentation cavity box makes with respect to the vertical as shown in Figure R6.

(8) Apply a forward force in the midsagittal plane through the adaptor bracket as shown in Figure R6 at any upper torso deflection rate between 0.5 and 1.5 degrees per second, until the angle reference plane reaches 45 degrees of flexion with the applied force at 58.0 to 62.0 degrees from horizontal.

(9) Continue to apply a force sufficient to maintain 45 degrees of flexion for 10 seconds, and record the highest applied force during the 10 second period.

(10) Release all force as rapidly as possible, and measure the return angle with respect to the initial angle reference plane as defined in paragraph (c)(7) of this section 3 minutes after the release.

§ 572.156 Test conditions and instrumentation.

(a) The test probe used for thoracic impact tests is a 100.6 mm (4 in) diameter cylinder that weighs 2.86+/-

–0.02 kg (6.3+/-0.04 lb), including instrumentation. Its impacting end has a flat right angle face that is rigid and has an edge radius of 12.7 mm (0.5 in). The test probe has an accelerometer mounted on the end opposite from impact with its sensitive axis co-linear to the longitudinal centerline of the cylinder.

(b) Head accelerometers have the dimensions, response characteristics, and sensitive mass locations specified in drawing SA572-S4 and are mounted in the head as shown in drawing 921022-000.

(c) The neck force-moment transducer has the dimensions, response characteristics, and sensitive axis locations specified in drawing SA 572-S23 and is mounted for testing as shown in figures R3 and R4.

(d) The shoulder force transducers have the dimensions and response characteristics specified in drawing SA572-S25 and are allowed to be mounted as an option in the torso assembly as shown in drawing 921022-000.

(e) The thorax accelerometers have the dimensions, response characteristics, and sensitive mass locations specified in drawing SA572-S4 and are mounted in the torso assembly in triaxial configuration as shown in drawing 921022-000.

(f) The lumbar spine force/moment transducer has the dimensions and

response characteristics specified in drawing SA572-S23 and is mounted in the torso assembly as shown in drawing 921022-000.

(g) The pelvis accelerometers have the dimensions, response characteristics, and sensitive mass locations specified in drawing SA572-S4 and are mounted within the pelvis in triaxial configuration as shown in drawing 921022-000.

(h) The pubic force transducers have the dimensions and response characteristics specified in drawing SA572-S24 and are mounted in the torso assembly as shown in drawing 921022-000.

(i) The outputs of acceleration and force-sensing devices installed in the dummy and in the test apparatus specified by this part are recorded in individual data channels that conform to the requirements of SAE Recommended Practice J211, Rev. Mar95 "Instrumentation for Impact Test," with channel classes as follows:

(1) Head and headform acceleration—Class 1000

(2) Neck :

(i) Forces—Class 1000

(ii) Moments—Class 600

(iii) Pendulum acceleration—Class 180

(3) Thorax:

(i) Spine and pendulum accelerations—Class 180

(ii) Shoulder forces—Class 600

(4) Lumbar:

(i) Forces—Class 1000

(ii) Moments—Class 600

(iii) Pendulum acceleration—Class 180

(5) Pelvis:

(i) Accelerations and forces—Class 1000

(ii) Moments—Class 600.

(j) Coordinate signs for instrumentation polarity conform to the Sign Convention For Vehicle Crash Testing, Surface Vehicle Information Report, SAE J1733, 1994-12.

(k) The mountings for sensing devices shall have no resonance frequency within range of 3 times the frequency range of the applicable channel class.

(l) Limb joints shall be set at 1 g, barely restraining the weight of the limb when it is extended horizontally. The force required to move a limb segment shall not exceed 2 g throughout the range of limb motion.

(m) Performance tests of the same component, segment, assembly, or fully assembled dummy shall be separated in time by period of not less than 30 minutes unless otherwise noted.

(n) Surfaces of dummy components are not painted except as specified in this part or in drawings subtended by this part.

BILLING CODE

Figure R 1
FRONTAL HEAD DROP TEST SET-UP SPECIFICATIONS

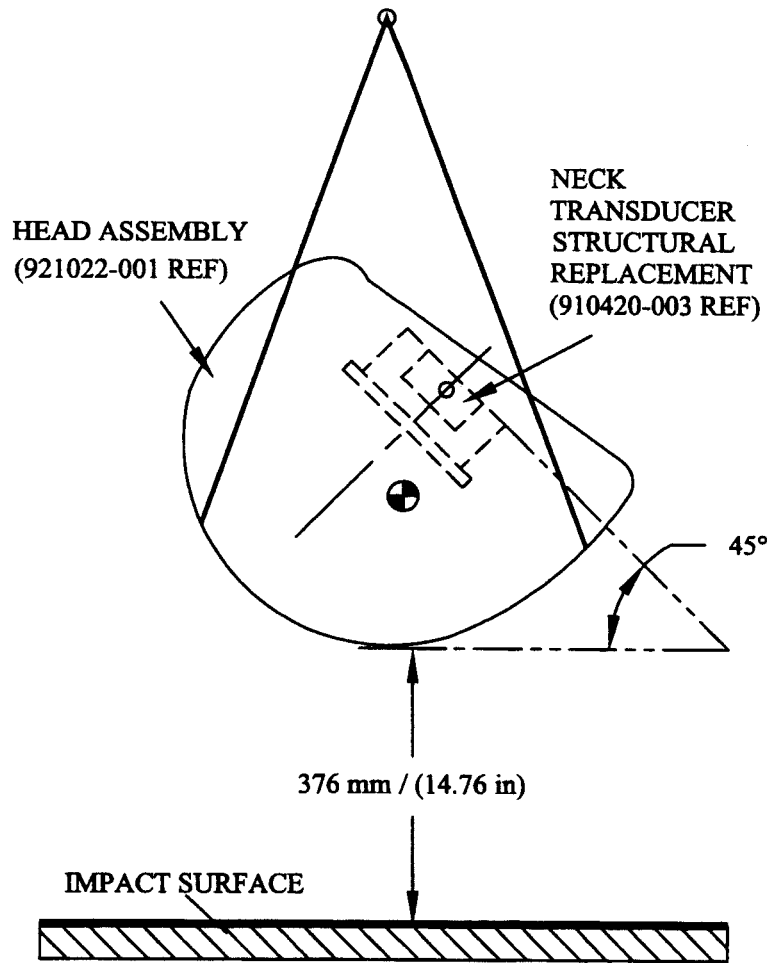

Figure R 2
REAR HEAD DROP TEST SET-UP SPECIFICATIONS

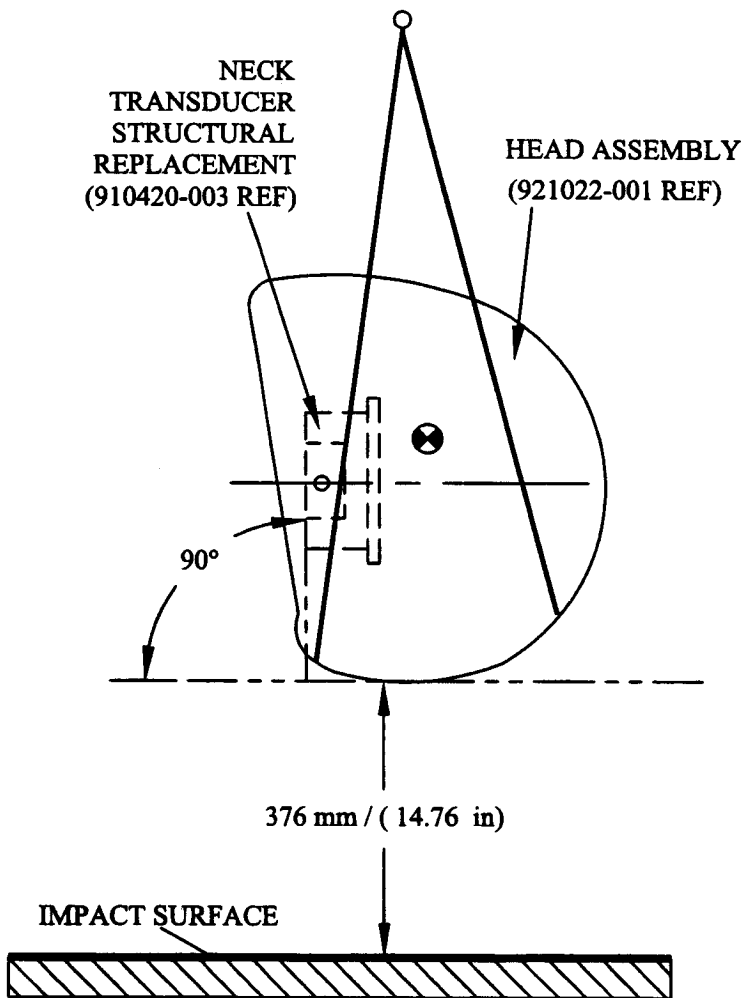
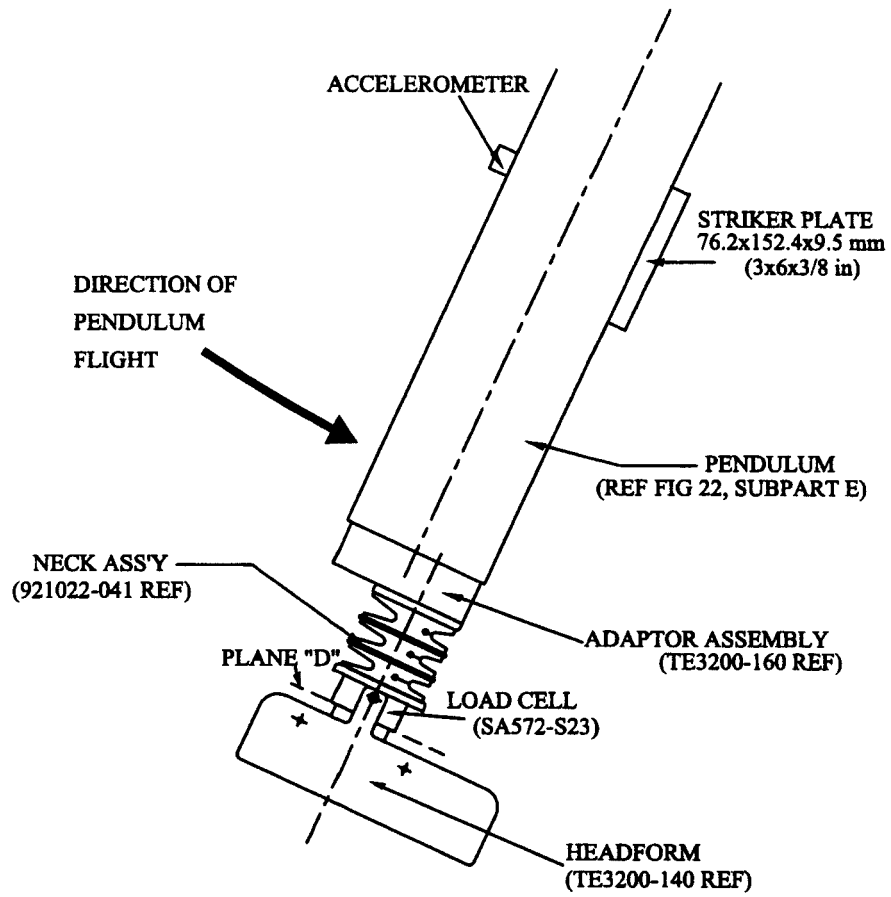
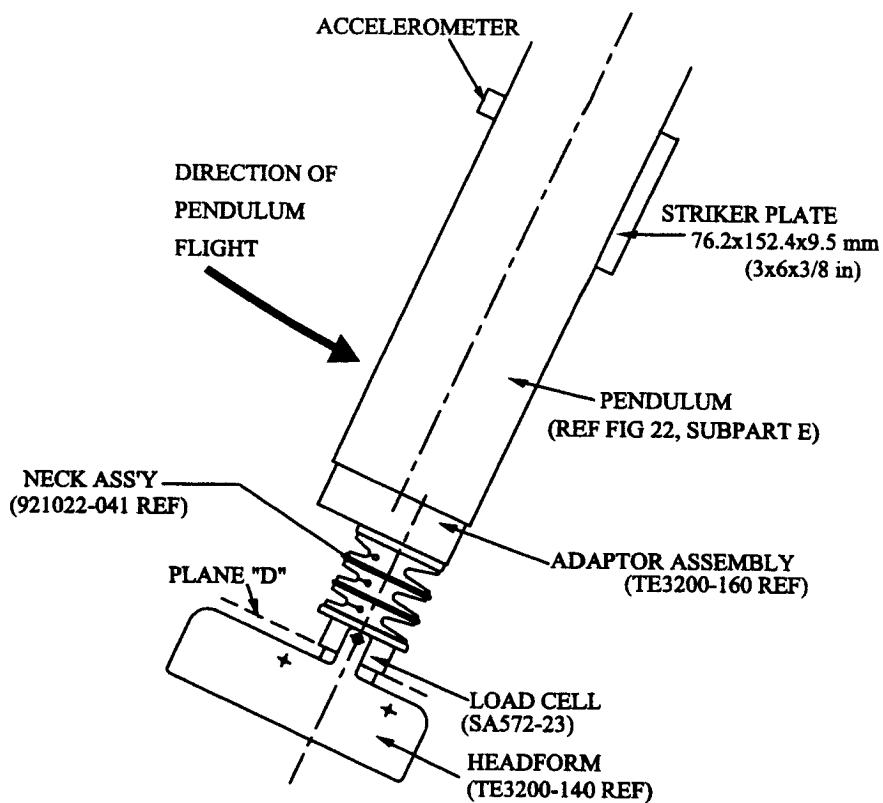

Figure R3
NECK FLEXION TEST SET-UP SPECIFICATIONS



NOTE: MOUNT NECK AT LEADING EDGE OF PENDULUM TO AVOID INTERFERENCE.

Figure R4
NECK EXTENSION TEST SET-UP SPECIFICATIONS



NOTE: MOUNT NECK AT LEADING EDGE OF PENDULUM TO AVOID INTERFERENCE.

Figure R 5
 THORAX IMPACT TEST SET-UP SPECIFICATIONS

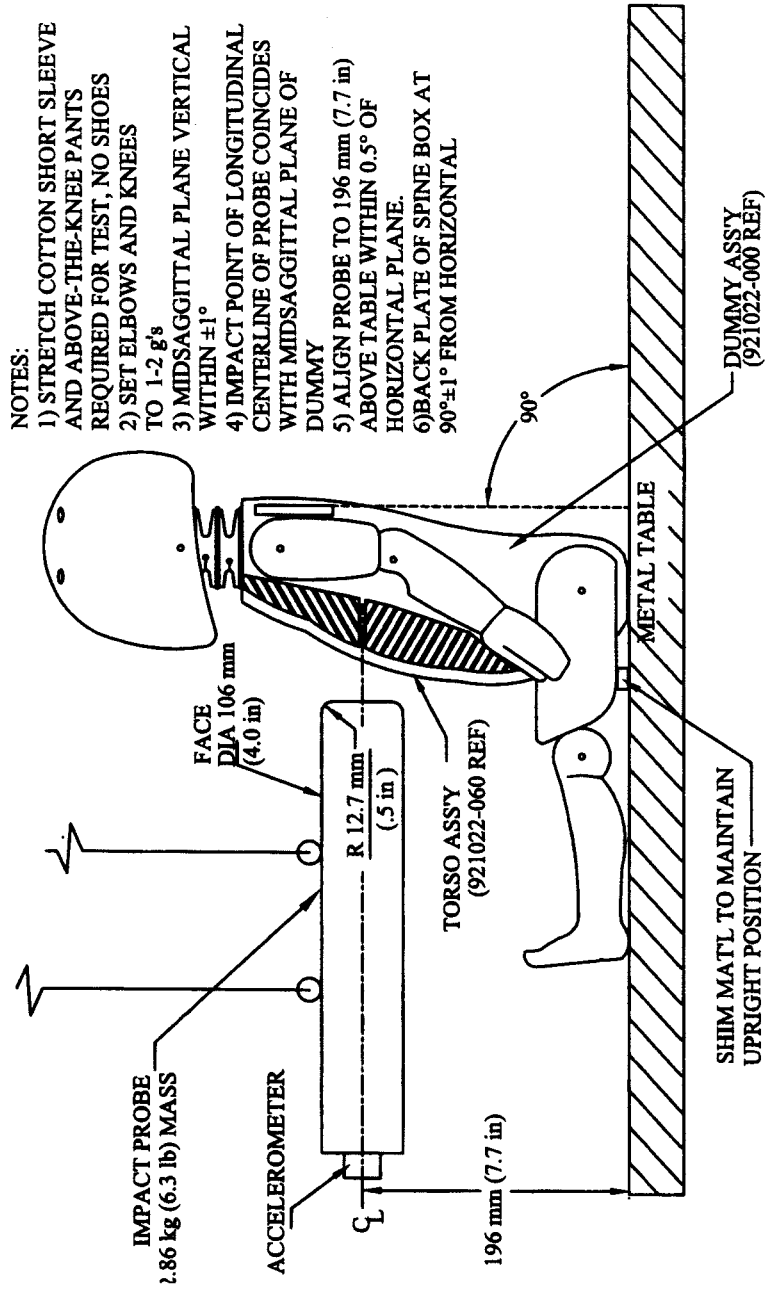

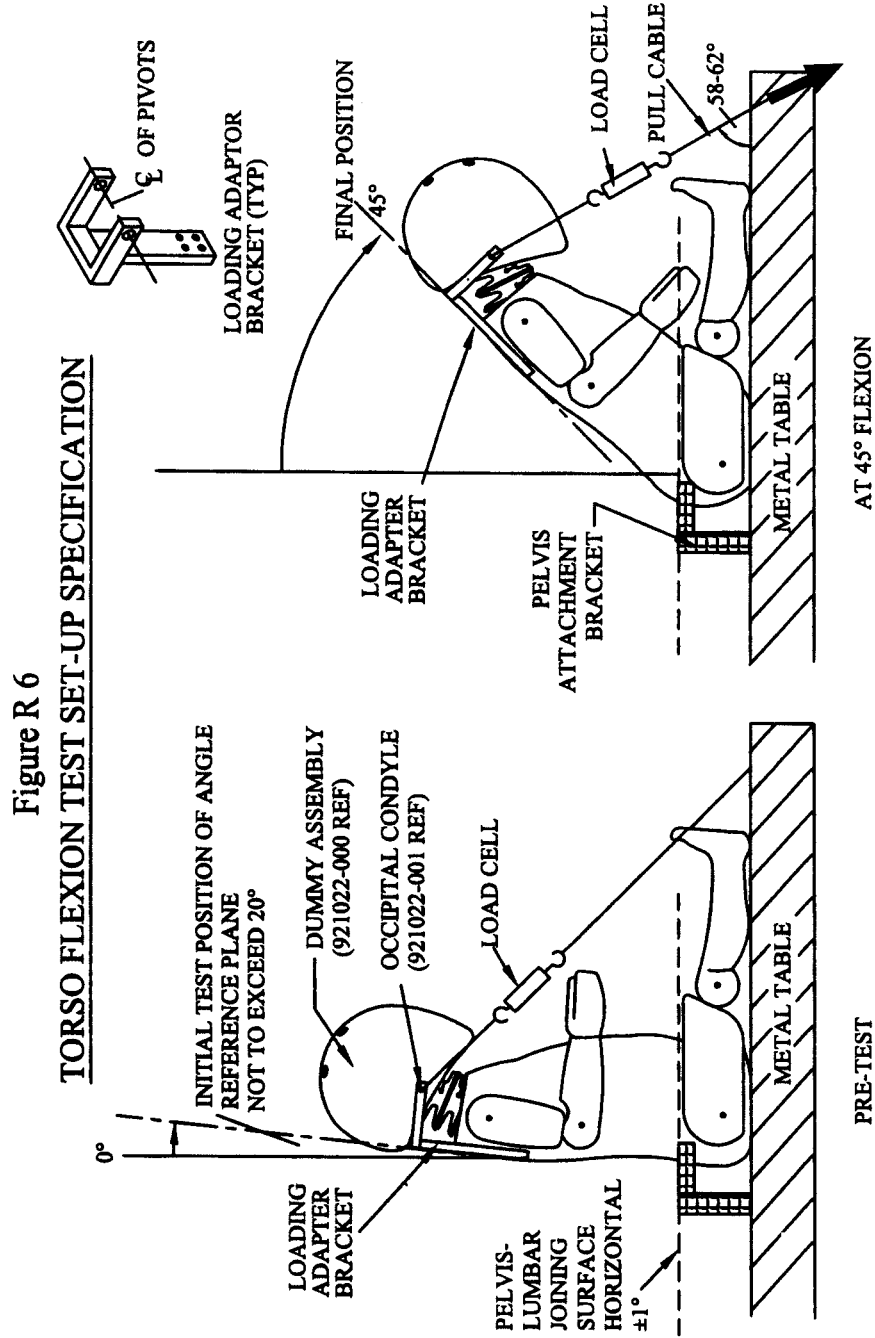

Issued March 2, 1999.

L. Robert Shelton,

Associate Administrator for Safety Performance Standards.

[FR Doc. 99-5509 Filed 3-5-99; 8:45 am]

BILLING CODE 4910-59-C