

resolved by the bureaus in consultation with the Commissioner, IRS.

c. With respect to matters discovered within the investigatory jurisdiction of a Department of Justice bureau or the Postal Service, IRS shall adhere to the provisions on notice and coordination in the "Memorandum of Understanding Among the Secretary of the Treasury, the Attorney General and the Postmaster General Regarding Money Laundering Investigations," dated August 16, 1990, or any such subsequent memorandum of understanding entered pursuant to 18 U.S.C. 1956(e) or 1957(e).

d. With respect to seizure and forfeiture operations and activities within its investigative jurisdiction, IRS shall comply with the policy, procedures, and directives developed and maintained by the Treasury Executive Office for Asset Forfeiture. Compliance will include adhering to the oversight, reporting, and administrative requirements relating to seizure and forfeiture contained in such policy, procedures, and directives.

6. *Ratification.* To the extent that any action heretofore taken consistent with this Directive may require ratification, it is hereby approved and ratified.

7. *Authorities.*

a. 18 U.S.C. 981, 1956 and 1957.

b. 31 U.S.C. 5311-5328 (other than violations of 31 U.S.C. 5316).

c. TO 101-05, "Reporting Relationships and Supervision of Officials, Offices and Bureaus, Delegation of Certain Authority, and Order of Succession in the Department of the Treasury," dated October 29, 1998, or successor documents.

d. TO 102-14, "Delegation of Authority with Respect to the Treasury Forfeiture Fund Act of 1992," dated January 10, 1995, or successor documents.

8. *Cancellation.* Treasury Directive 15-42, "Delegation of Authority to the Commissioner, Internal Revenue Service to Perform Functions Under the Money Laundering Control Act of 1986, as amended," dated September 11, 1995, is superseded.

9. *Expiration Date.* This Directive shall expire three years from the date of issuance unless superseded or canceled prior to that date.

10. *Office of Primary Interest.* Office of the Under Secretary (Enforcement).

**James E. Johnson,**

*Under Secretary (Enforcement).*

[FR Doc. 99-2869 Filed 2-5-99; 8:45 am]

BILLING CODE 4810-25-P

## DEPARTMENT OF THE TREASURY

[Treasury Order Number 101-05]

### Reporting Relationships and Supervision of Officials, Offices and Bureaus, Delegation of Certain Authority, and Order of Succession in the Department of the Treasury

January 7, 1999.

By virtue of the authority vested in the Secretary of the Treasury, including the authority vested by 31 U.S.C. 321(b), and Executive Order (E.O.) 11822, dated December 10, 1974, it is ordered that:

1. The Deputy Secretary shall report directly to the Secretary.

2. The Chief of Staff shall report directly to the Secretary and shall exercise supervision over the Director, Secretary's Scheduling Office, and the Executive Secretary.

3. The Executive Secretary shall report directly to the Chief of Staff and shall exercise supervision over the functions of the Executive Secretariat Correspondence Unit; the Office of Public Correspondence; and, for purposes of administrative and managerial control, over the Special Assistant to the Secretary (National Security). The Special Assistant to the Secretary (National Security) shall report to the Secretary and the Deputy Secretary.

4. The following officials shall report through the Deputy Secretary to the Secretary and shall exercise supervision over those officers and organizational entities set forth on the attached organizational chart:

Under Secretary (International Affairs)  
Under Secretary (Domestic Finance)  
Under Secretary (Enforcement)  
General Counsel  
Assistant Secretary (Legislative Affairs and Public Liaison)  
Assistant Secretary (Public Affairs)  
Assistant Secretary (Economic Policy)  
Assistant Secretary (Tax Policy)  
Assistant Secretary (Management) and Chief Financial Officer  
Commissioner of Internal Revenue  
Comptroller of the Currency  
Director, Office of Thrift Supervision

5. The Inspector General and the Treasury Inspector General for Tax Administration shall report to and be under the general supervision of the Secretary and the Deputy Secretary.

6. The Assistant Secretary (Management) serves as the Department's Chief Financial Officer pursuant to Chapter 9 of Title 31, U.S.C., and serves as the Department's Chief Operating Officer for purposes of the Presidential Memorandum, "Implementing Management Reform in

the Executive Branch," dated October 1, 1993.

7. The Deputy Assistant Secretary (Information Systems) reporting to the Assistant Secretary (Management) and Chief Financial Officer is designated as the Department's Chief Information Officer pursuant to Division E of the Clinger-Cohen Act of 1996, and E.O. 13011, dated July 16, 1996, and shall have direct access to the Secretary to the extent required by that Act and related statutes.

8. The Deputy Secretary is authorized, in that official's own capacity and that official's own title, to perform any functions the Secretary is authorized to perform and shall be responsible for referring to the Secretary any matter on which action would appropriately be taken by the Secretary. Any action heretofore taken by the Deputy Secretary in that official's own title is hereby affirmed and ratified as the action of the Secretary.

9. The Under Secretaries, the General Counsel, and the Assistant Secretaries are authorized to perform any functions the Secretary is authorized to perform. Each of these officials will ordinarily perform under this authority only functions which arise out of, relate to, or concern the activities or functions of, or the laws administered by or relating to, the bureaus, offices, or other organizational units over which the incumbent has supervision. Each of these officials shall perform under this authority in the official's own capacity and the official's own title and shall be responsible for referring to the Secretary any matter on which action would appropriately be taken by the Secretary. Any action heretofore taken by any of these officials in that official's own title is hereby affirmed and ratified as the action of the Secretary.

10. The following officials shall, in the order of succession indicated, act as Secretary of the Treasury in case of the death, resignation, absence or sickness of the Secretary and other officers succeeding the incumbent, until a successor is appointed, or until the absence or sickness shall cease:

a. Deputy Secretary;

b. The following individuals, in the order of the date on which they were first appointed to a position within the Department requiring appointment by the President by and with the advice and consent of the Senate:

- Under Secretary (International Affairs);
  - Under Secretary (Domestic Finance); and
  - Under Secretary (Enforcement);
- c. General Counsel; and

d. Assistant Secretaries, appointed by the President with Senate confirmation, in the order designated by the Secretary.

11. *Cancellation.* Treasury Order 101-05, "Reporting Relationships and Supervision of Officials, Offices and Bureaus, Delegation of Certain Authority, and Order of Succession in the Department of the Treasury," dated October 29, 1998, is superseded as of this date.

12. *Office of Primary Interest.* Office of Organizational Improvement.

**Robert E. Rubin,**

*Secretary of the Treasury.*

Attachment

BILLING CODE 4810-25-P

THE DEPARTMENT OF THE TREASURY

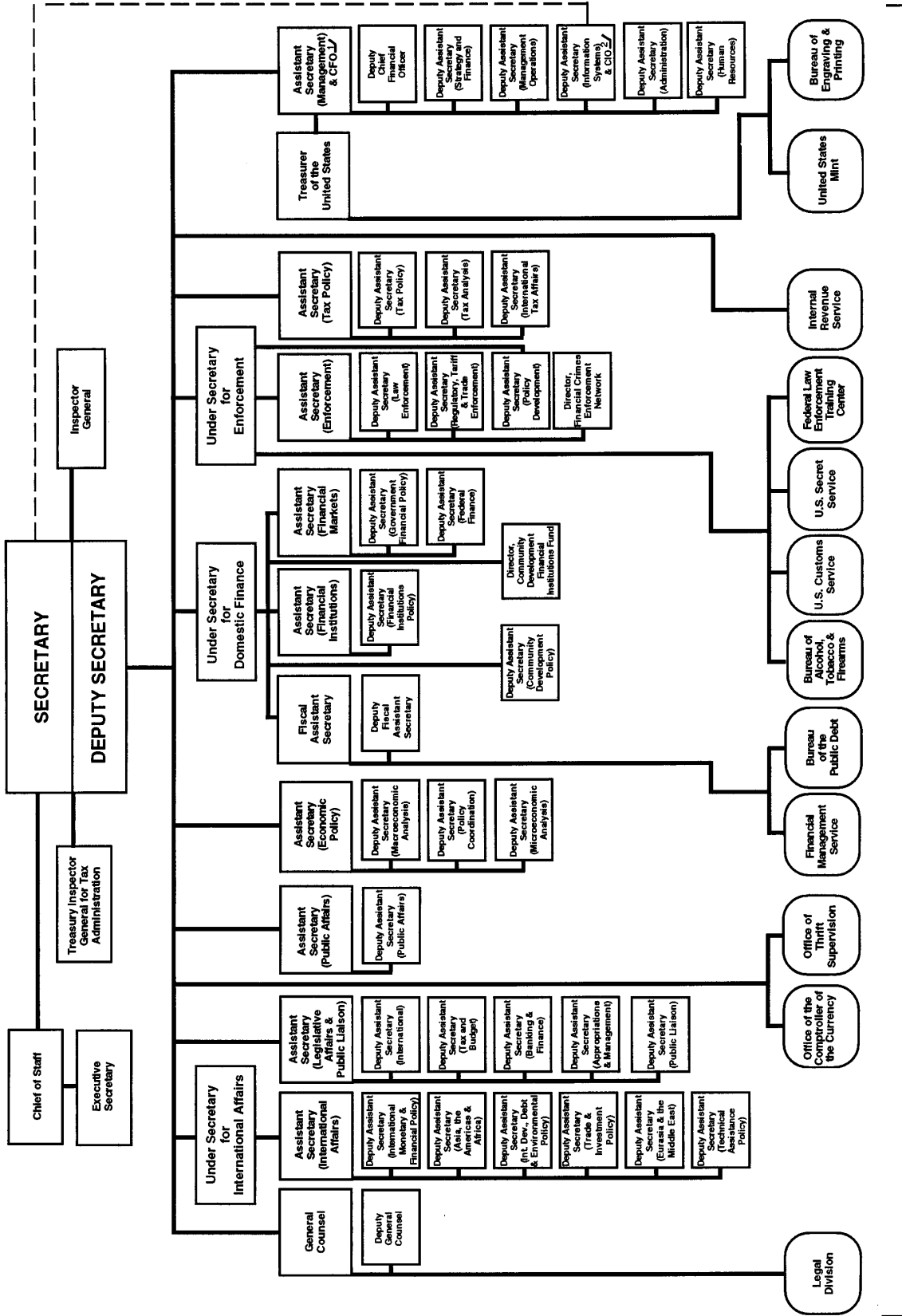

✓ Assistant Secretary (Management) and Chief Financial Officer is Treasury's Chief Operating Officer.  
 ✎ Deputy Assistant Secretary (Information Systems) is the Chief Information Officer (CIO)