

would this have on preference cargo transportation?

5. Definition of Commercial Terms

The use of special government-defined terms of sale and transportation for preference cargoes sometimes creates confusion in the marketplace and increases costs. Commercial suppliers and carriers use commercial terms for the majority of their business but must use non-standard government terms when dealing with the U.S. Government. For example, the U.S. Department of Agriculture (USDA) and the Agency for International Development (AID) have defined the term "FAS" (free along side) to mean delivery to a point of rest in a terminal rather than the International Commercial Terms (Incoterms) definition of "FAS (* * * named port)" as "alongside the vessel on the quay or in the lighters at the named port of shipment." As a result, MARAD interprets the government definition to not require that a vessel physically call at the port whereas the commercial Incoterm definition requires a physical vessel call. Similarly, USDA and AID use other non-standard terms, such as "Intermodal-Plant" and "Intermodal-Point" with different buyer/seller/carrier responsibilities than the commercial Incoterm "EXWorks (. . . named place)."

We welcome your comments on whether MARAD should require the use of commercial terms for cargo preference transactions. Would this clarify the sales and transportation requirements? Would it simplify the process and reduce overall government costs?

6. Commercial Practices

The use of non-commercial practices in government cargo preference transportation contracts may be reducing competition and increasing costs. For example, USDA and AID transportation contracts do not follow the general commercial practices of "freight earned upon loading" and "freight payable on loading," or "free-in and out" for dry bulk charters. As a result, the ocean carrier has to finance the costs of moving these government agricultural cargoes. Those added financial costs to the carrier are reflected in higher freight rates borne by the Government.

Should MARAD require the use of commercial practices in the transportation of preference cargoes? If so, what commercial practices should be implemented? Would such commercial practices simplify the transportation

contracts and reduce costs to the Government?

7. Other Issues

This request for comments concerning the desirability of rulemaking is not limited to the foregoing. MARAD also seeks comments and/or suggestions concerning other issues that may affect the implementation of the cargo preference statutes and whether MARAD's regulations should be amended or modified in light of such issues.

Rulemaking Analysis and Notices

Executive Order 12866 (Regulatory Planning and Review)

If a rule is actually promulgated, we may consider it an economically significant regulatory action under section 3(f) of E.O. 12866. In the event that MARAD decides to proceed with a rulemaking, we will prepare a preliminary regulatory evaluation that reflects the comments to this advance notice of proposed rulemaking.

Federalism

MARAD has analyzed this advance notice of proposed rulemaking in accordance with the principles and criteria contained in Executive Order 12612 and has determined that any rule that might be subsequently promulgated would not have sufficient federalism implications to warrant the preparation of a Federalism Assessment.

Regulatory Flexibility Act

The Maritime Administration will evaluate any future proposed rule under the Regulatory Flexibility Act of 1980, 5 U.S.C. 601-612, to certify whether any rule that might be promulgated subsequent to this advance notice of proposed rulemaking would have a significant economic impact on a substantial number of small entities. Companies providing the carriage of preference cargoes generally are not small entities.

EIS

Any rule that might be subsequently promulgated would not be expected to significantly affect the environment. Accordingly, an Environmental Impact Statement may not be required under the National Environmental Policy Act of 1969.

Paperwork Reduction Act

We would evaluate any rule that might be promulgated to determine whether it would be expected to significantly change the current requirement for the collection of information.

By order of the Maritime Administrator.

Dated: January 25, 1999.

Joel C. Richard,

Secretary.

[FR Doc. 99-2046 Filed 1-27-99; 8:45 am]

BILLING CODE 4910-81-P

DEPARTMENT OF TRANSPORTATION

National Highway Traffic Safety Administration

49 CFR Part 572

[Docket No. NHTSA-99-5032]

RIN 2127-AG 77

Anthropomorphic Test Dummy; Occupant Crash Protection

AGENCY: National Highway Traffic Safety Administration (NHTSA), Department of Transportation.

ACTION: Notice of proposed rulemaking.

SUMMARY: This document proposes to adopt design and performance specifications for a new 3-year-old child dummy. The agency believes that the new dummy, part of the family of Hybrid III test dummies, is more representative of humans than the existing 3-year old child dummy specified by agency regulations. Further, it allows the assessment of the potential for more types of injuries. The new dummy is especially needed to evaluate the effects of air bag deployment on out-of-position children. It would also provide greater and more useful information in a variety of environments to better evaluate child safety. Adopting the dummy would be the first step toward using the dummy to evaluate the safety of air bags for children. The issue of specifying use of the dummy in determining compliance with performance tests, e.g., as part of the agency's occupant protection standard and/or child restraint standard, is being addressed in other rulemakings, most notably the proposed advanced air bag rulemaking currently pending before the agency.

DATES: Comments must be received by March 29, 1999.

ADDRESSES: Comments should refer to the docket number, and be submitted to: Docket Management, Room PL-401, 400 Seventh Street, SW, Washington, DC 20590 (Docket hours are from 10 a.m. to 5 p.m.)

FOR FURTHER INFORMATION CONTACT: For nonlegal issues: Stan Backaitis, Office of Crashworthiness Standards (telephone: 202-366-4912).

For legal issues: Rebecca MacPherson, Office of the Chief Counsel (202-366-2992).

Both can be reached at the National Highway Traffic Safety Administration, 400 Seventh St., SW, Washington, DC 20590.

SUPPLEMENTARY INFORMATION: The need for a new 3-year-old dummy has become urgent with the emergence of the safety problems that current air bags pose for out-of-position children. Experience in using the existing 3-year-old dummy in subpart C of part 572 has shown it to be adequate for the purpose of evaluating child restraints for the injury criteria and test conditions specified by Standard No. 213, Child restraint systems. However, that dummy is limited with respect to the types of injury risks it can measure, particularly in an air bag environment.

For example, since neck injury is one of the primary causes of air bag-related fatalities to out-of-position children, a dummy must have a high degree of biofidelity in areas such as impact responses in neck flexion and extension motion to evaluate the effects of air bag deployment. However, the neck of the existing subpart C dummy does not have a multi-segment design. Accordingly, it has limited biofidelity in these areas.

By contrast, the more advanced Hybrid III 3-year-old child dummy (hereafter referred to as the H-III3C dummy) provides a more human-like impact response than the subpart C dummy as well as a broader selection of instrumented measurements to assess the injury potential to child occupants. Of particular significance is the multi-segmented neck, multi-rib thorax, and the ability to monitor submarining tendencies related to abdominal loading. Because of the greater biofidelity and extended measurement capability of the H-III3C dummy, it can be used to evaluate the safety of children in a much wider array of environments than the existing dummy, including assessing the effects of air bag deployment on out-of-position children. The agency notes that the H-III3C dummy is the only advanced 3-year-old child dummy that has been developed and evaluated to date.

The H-III3C dummy is part of a family of Hybrid III-type dummies. The first Hybrid III dummy was a 50th percentile male dummy. NHTSA has specified use of this dummy for compliance testing under Standard No. 208, *Occupant Crash Protection*, since 1986, initially on an optional basis, and more recently on a mandatory basis.

The need for a family of Hybrid III-type dummies having considerably

improved biofidelity and anthropometry was recognized by the Centers for Disease Control and Prevention (CDC) in 1987 when it awarded a contract to Ohio State University under the title "Development for Multi-sized Hybrid III Based Dummy Family." At that time, the funding covered only the development of a small female and a large male dummy.

Development of a Hybrid III 3-year-old dummy began in 1992 when the SAE Small Female, Large Male and Six Year Old Child Dummies Task Group¹ identified a need for a new dummy equipped with sufficient instrumentation capable of assessing a child's interaction with both air bags and child restraints. The task group noted that the dummy should be suitable for use in sitting, kneeling and standing postures. After a preliminary design was conceived and reviewed, a prototype dummy was developed and made available to the task group in July 1994. Initial evaluation of the dummy revealed numerous structural and functional problems. Prior to testing by NHTSA, the dummy designer, under the guidance of the SAE Hybrid III Dummy Family Task Group, addressed additional structural and impact response problems revealed through testing of the revised prototype throughout 1995, 1996, and early 1997. In May 1997, NHTSA initiated a thorough test and evaluation program in anticipation of formal rulemaking.

The agency has now completed its evaluation of the H-III3C dummy and has tentatively concluded that it is ready for incorporation into part 572. NHTSA is placing in the docket a technical report entitled "Development and Evaluation of the Hybrid III 3-Year-Old Child Dummy." That report provides the technical information supporting this rulemaking.

Accordingly, the agency is proposing specifications and performance criteria for the H-III3C dummy. The specifications would consist of the following two items:

- (1) A drawings and specifications package entitled "Parts List and Drawings for the Hybrid III 3-Year-Old Dummy (October 1998)"; and
- (2) A user's manual entitled "User's Manual for the Hybrid III 3-Year-Old Test Dummy [a date would be inserted in the final rule]".

In order to allow comment on the general content and format of the user's manual, NHTSA has placed in the

¹The task group has been renamed the "Hybrid III Dummy Family Task Group". Minutes of the task groups meetings are available for review in the NHTSA docket (Docket no. NHTSA98-4283).

docket a copy of a manual entitled "Hybrid III 3-Year-Old Child Dummy User's Manual", SAE Engineering Aid 31 (rev. June 25, 1998).

The specifications are intended to ensure that the dummies are uniform in their construction and capable of uniform and repeatable response in the impact environment. The agency notes that the first item listed above, the parts list and drawings, will be available for inspection in NHTSA's docket. (Since this item is non-scannable, it cannot be placed in the DOT Dockets Management System (DMS). Instead a statement indicating where it may be viewed, i.e., in NHTSA's docket, will be placed in the DMS.) Copies may also be obtained from Reprographic Technologies, 9000 Virginia Manor Road, Beltsville, MD 20705; Telephone: (301) 210-5600.

As with other dummies, NHTSA is proposing impact performance criteria to serve as calibration checks, and to further assure the kinematic uniformity of the dummy and the absence of structural damage and functional deficiency from previous use. The tests address head, neck, and thorax impact responses and resistance assessments of the lumbar spine-abdomen area to torso flexion motion.

The agency is proposing generic specifications for all of the dummy-based sensors. For most earlier dummies, the agency specified sensors by make and model. However, NHTSA believes that approach is unnecessarily restrictive and limits innovation and competition.

The proposed specifications are essentially generic and reflect performance characteristics of the sensors used in NHTSA's dummy evaluation series that are identified by make and model in the above-referenced technical report "Development and Evaluation of the Hybrid III 3-year-old Child Dummy." Specifications for the proposed sensors are included in the drawing package. Interested persons are encouraged to comment on the adequacy of the proposed specifications; the potential impact on the quality of measurements to be acquired, including the comparability of data using sensors manufactured by different companies; and issues related to calibration assurance tests.

NHTSA notes that the H-III3C dummy is the third of several new dummies it is proposing to add to part 572. The agency has already proposed adding a new, advanced 6-year-old dummy (H-III6C) (63 FR 35170) and a fifth percentile small adult female dummy (H-III5F) (63 FR 46981). Within the next six weeks, it plans to propose adding the CRABI 12-month-old child

dummy. The agency intends to use these dummies in connection with its rulemaking for advanced air bags which is currently in the notice and comment stage (63 FR 49958). All of these dummies could be specified for use in a variety of potential Standard No. 208 tests, including static out-of-position tests and/or various dynamic tests. The child dummies could also be specified for use in Standard No. 213 tests.

This notice only concerns the H-III3C dummy, and is only proposing to add the dummy to part 572. The issue of specifying the use of the H-III3C dummy as part of Standard No. 208 is addressed in the advanced air bag rulemaking and may be addressed in a future rulemaking regarding Standard No. 213. However, since one of the primary purposes of adding the dummy to part 572 is to enable it to be specified for use in the Federal motor vehicle safety standards, NHTSA encourages commenters to address its suitability for tests related to occupant crash protection, e.g., those discussed or proposed in the NPRM on advanced air bags. The agency also encourages commenters to address the dummy's suitability with respect to measuring proposed and other injury criteria.²

Rulemaking Analyses and Notices

A. Executive Order 12866 and DOT Regulatory Policies and Procedures

NHTSA has considered the impact of this rulemaking action under Executive Order 12866 and the Department of Transportation's regulatory policies and procedures. This rulemaking document was not reviewed by the Office of Management and Budget under E.O. 12866, "Regulatory Planning and Review." The rulemaking action has been determined not to be significant under the Department's regulatory policies and procedures.

This document proposes to amend 49 CFR part 572 by adding design and performance specifications for a new, more advanced 3-year old child dummy which the agency may later separately propose for use in the Federal motor vehicle safety standards. If this proposed rule becomes final, it would directly affect only those businesses which choose to manufacture or test with the dummy. Vehicle manufacturers could be indirectly affected under the advanced air bag rulemaking currently

pending before the agency. It does not impose any requirements on anyone.

The cost of an instrumented H-III3C dummy would be between \$44,000 and \$80,000, with an uninstrumented H-III3C dummy costing approximately \$30,000 and instrumentation costing approximately \$14,000 to \$50,000 (depending on the amount of data channels the user chooses to collect).

Because the economic impacts of this proposal are so minimal, no further regulatory evaluation is necessary.

B. Regulatory Flexibility Act

NHTSA has considered the effects of this rulemaking action under the Regulatory Flexibility Act (5 U.S.C. 601 *et seq.*) I hereby certify that the proposed amendment would not have a significant economic impact on a substantial number of small entities. The proposed amendment would not impose or rescind any requirements for anyone. Therefore, it would not have a significant economic impact on a substantial number of small entities.

C. National Environmental Policy Act

NHTSA has analyzed this proposed amendment for the purposes of the National Environmental Policy Act and determined that it would not have any significant impact on the quality of the human environment.

D. Executive Order 12612 (Federalism)

The agency has analyzed this proposed amendment in accordance with the principles and criteria set forth in Executive Order 12612. NHTSA has determined that the proposed amendment does not have sufficient federalism implications to warrant the preparation of a Federalism Assessment.

E. Unfunded Mandates Act

The Unfunded Mandates Reform Act of 1995 requires agencies to prepare a written assessment of the costs, benefits and other effects of proposed or final rules that include a Federal mandate likely to result in the expenditure by State, local or tribal governments, in the aggregate, or by the private sector, of more than \$100 million annually (adjusted for inflation with base year of 1995). This proposal does not meet the definition of a Federal mandate because it does not impose requirements on anyone. In addition, annual expenditures would not exceed the \$100 million threshold.

F. Executive Order 12778 (Civil Justice Reform)

This proposed rule would not have any retroactive effect. Under 49 U.S.C. 30103, whenever a Federal motor

vehicle safety standard is in effect, a State may not adopt or maintain a safety standard applicable to the same aspect of performance which is not identical to the Federal standard, except to the extent that the state requirement imposes a higher level of performance and applies only to vehicles procured for the State's use. 49 U.S.C. 30161 sets forth a procedure for judicial review of final rules establishing, amending or revoking Federal motor vehicle safety standards. That section does not require submission of a petition for reconsideration or other administrative proceedings before parties may file suit in court.

G. Paperwork Reduction Act

In accordance with the Paperwork Reduction Act of 1980 (P.L. 96-511), there are no requirements for information collection associated with this proposed rule.

Request for Comments

Interested persons are invited to submit comments on this proposal. Two copies should be submitted.

All comments must not exceed 15 pages in length (49 CFR 553.21). Necessary attachments may be appended to these submissions without regard to the 15-page limit. This limitation is intended to encourage commenters to detail their primary arguments in a concise fashion.

If a commenter wishes to submit certain information under a claim of confidentiality, three copies of the complete submission, including purportedly confidential business information, should be submitted to the Chief Counsel, NHTSA, at the street address given above, and two copies from which the purportedly confidential information has been deleted should be submitted to the Docket Section. A request for confidentiality should be accompanied by a cover letter setting forth the information specified in the agency's confidential business information regulation. 49 CFR part 512.

All comments received by NHTSA before the close of business on the comment closing date indicated above will be considered, and will be available for examination in the docket at the above address both before and after that date. To the extent possible, comments filed after the closing date will also be considered. Comments received too late for consideration in regard to this action will be considered as suggestions for further rulemaking action. Comments will be available for inspection in the docket. NHTSA will continue to file relevant information as it becomes available in the docket after the closing

² For information concerning potential injury criteria, see *Development of Improved Injury Criteria for the Assessment of Advanced Automotive Restraint Systems*, June, 1998, Docket No. NHTSA98-4405-9. (Available on the NHTSA website at <http://www.nhtsa.dot.gov>.)

date, and recommends that interested persons continue to examine the docket for new material.

Those persons desiring to be notified upon receipt of their comments in the rules docket should enclose a self-addressed, stamped postcard in the envelope with their comments. Upon receiving the comments, the docket supervisor will return the postcard by mail.

List of Subjects in 49 CFR Part 572

Motor vehicle safety.

In consideration of the foregoing, NHTSA proposes to amend 49 CFR part 572 as follows:

Part 572—Anthropomorphic Test Dummies

1. The authority citation for part 572 would continue to read as follows:

Authority: 49 USC 332, 30111, 30115, 30117; and 30166 delegation of authority at 49 CFR 1.50.

2. 49 CFR Part 572 would be amended by adding a new Subpart P consisting of 572.140–572.146 to read as follows:

Subpart P—3-year-Old Child

Sec.

572.140 Incorporation by reference.

572.141 General description.

- 572.142 Head assembly and test procedure.
- 572.143 Neck-headform assembly and test procedure.
- 572.144 Thorax assembly and test procedure.
- 572.145 Upper and lower torso assemblies and torso flexion test procedure.
- 572.146 Test Condition and Instrumentation.

Subpart P—3-year-Old Child

§ 572.140 Incorporation by reference.

(a) The following materials are hereby incorporated in this subpart P by reference:

- (1) A drawings and specifications package entitled “Parts List and Drawings for the Hybrid III 3-year-old dummy (October 1998)”;
- (2) A user’s manual entitled “Operations and Maintenance Manual for the Hybrid III 3-year-old test dummy [a date will be inserted in the final rule]”;
- (3) SAE Recommended Practice J211, Rev. Mar95 “Instrumentation for Impact Tests”;
- (4) SAE J1733 of 1994–12 “Sign Convention for Vehicle Crash Testing”.
- (5) The Director of the **Federal Register** approved those materials incorporated by reference in accordance with 5 U.S.C. 552(a) and 1 CFR part 51. Copies of the materials may be

inspected at NHTSA’s Docket Section, 400 Seventh Street SW, room 5109, Washington, DC, or at the Office of the Federal Register, 800 North Capitol Street, NW, Suite 700, Washington, DC.

(b) The incorporated materials are available as follows:

- (1) The drawings and specifications package referred to in paragraph (a)(1) of this section and the user’s manual referred to in paragraph (a)(2) of this section are available from Reprographic Technologies, 9000 Virginia Manor Road, Beltsville, MD 20705, (301) 419–5070.
- (2) The SAE materials referred to paragraphs (a)(3) and (a)(4) of this section are available from the Society of Automotive Engineers, Inc., 400 Commonwealth Drive, Warrendale, PA 15096.

§ 572.141 General description.

(a) The representative 3-year-old is described by the following materials:

- (1) Technical drawings and specifications package 210–0000, the titles of which are listed in Table A;
- (2) Operation and Maintenance Manual (to be incorporated at issuance of final rule);
- (b) The dummy is made up of the component assemblies set out in the following Table A:

TABLE A

Component assembly	Drawing No.
Head Assembly	210–1000.
Neck Assembly (complete)	210–2001.
Upper/Lower Torso Assembly	210–3000.
Leg Assembly	210–5000–1(L),–2(R).
Arm Assembly	210–6000–1(L),–2(R).

(c) Adjacent segments are joined in a manner such that except for contacts existing under static conditions, there is no contact between metallic elements throughout the range of motion or under simulated crash impact conditions.

(d) The structural properties of the dummy are such that the dummy conforms to this part in every respect before its use in any test similar to those specified in Standard Nos. 208, Occupant Crash Protection, and 213, Child Restraint Systems.

§ 572.142 Head assembly and test procedure.

(a) The head assembly for this test consists of the assembly (drawing 210–1000), the adapter plate (drawing ATD 6259), accelerometer mounting block (drawing SA–572–S80), mass simulation of 1/2 neck load transducer (drawing

TE–107–001), and 3 accelerometers (drawing SA–572–S4).

(b) When the head assembly in paragraph (a) of this section is dropped from a height of 376.0+/- 1.0 mm (14.8+/- 0.04 in) in accordance with paragraph (c) of this section, the peak resultant acceleration at the location of the accelerometers at the head CG shall not be less than 250 g or more than 280 g. The resultant acceleration versus time history curve shall be unimodal, and the oscillations occurring after the main pulse shall be less than 10 percent of the peak resultant acceleration. The lateral acceleration shall not exceed +/- 15 g’s.

(c) Head test procedure. The test procedure for the head is as follows:

- (1) Soak the head assembly in a controlled environment at any temperature between 18.9 and 25.6 °C (66 and 78 °F) and at any relative

humidity between 10 and 70 percent for at least four hours prior to a test.

(2) Prior to the test, clean the impact surface of the head skin and the steel impact plate surface with isopropyl alcohol, trichlorethane, or an equivalent. Both impact surfaces must be clean and dry for testing.

(3) Suspend the head assembly with its midsagittal plane in vertical orientation as shown in Figure P1. The lowest point on the forehead is 376.0+/- 1.0 mm (14.8 +/- 0.04 in) from the steel impact surface. The 1.57 mm (0.062 in.) diameter holes located on either side of the dummy’s head in transverse alignment with the CG, are used to ensure that the head transverse plane is level with respect to the impact surface. The angle between the lower surface plane of the neck transducer mass simulator (TE–107–001) and the

plane of the impact surface is 62 +/- 1 degrees.

(4) Drop the head assembly from the specified height by a means that ensures a smooth, instant release onto a rigidly supported flat horizontal steel plate which is 51 mm (2 in) thick and 610 mm (24 in) square. The impact surface shall have a finish of not less than 0.2 microns (8 micro inches) (RMS) and not more than 2 microns (80 micro inches) (RMS).

(5) Allow at least 2 hours between successive tests on the same head.

§ 572.143 Neck-headform assembly and test procedure.

(a) The neck and headform assembly for the purposes of this test consist of the neck (drawing 210-2015), neck cable (drawing 210-2040), lower mount plate insert (drawing 9001373), upper mount plate insert (drawing 910420-048), bib simulator (drawing TE208-050), urethane washer (drawing 210-2050), neck mounting plate (drawing TE250-021), two jam nuts (drawing 9001336), load-moment transducer (drawing SA-572-S19), and head form (drawing TE208-000).

(b) When the neck and headform assembly, as defined in paragraph (a) of this section, is tested according to the test procedure in paragraph (c) of this section, it shall have the following characteristics:

(1) Flexion.

(i) Plane D referenced in Figure P2 shall rotate in the direction of preimpact flight with respect to the pendulum's longitudinal centerline not less than 70 degrees and not more than 82 degrees

occurring between 45 milliseconds (ms) and 60 ms after time zero.

(ii) The peak moment measured by the neck transducer (drawing SA-572-S19) about the occipital condyles shall have a value not less than 44 Nm (32.4 ft-lb) and not more than 56 Nm (41.3 ft-lbs) occurring within the minimum and maximum rotation interval and the positive moment shall decay for the first time to 10 Nm (7.4 ft-lb) between 60 ms and 80 ms.

(2) Extension.

(i) Plane D referenced in Figure P3 shall rotate in the direction of preimpact flight with respect to the pendulum's longitudinal centerline not less than 80 degrees and not more than 90 degrees occurring between 50 ms and 65 ms after time zero.

(ii) The peak negative moment measured by the neck transducer (drawing SA-572-S19) about the occipital condyles shall have a value not more than -42 Nm (-31.0 ft-lb) and not less than -53 Nm (-39.1 ft-lb) occurring within the minimum and maximum rotation interval and the negative moment shall decay for the first time to -10Nm (-7.4 ft-lb) between 60 and 80 ms after time zero.

(3) Time-zero is defined as the time of initial contact between the pendulum striker plate and the honeycomb material.

(c) Test Procedure.

(1) Soak the neck assembly in a controlled environment at any temperature between 20.6 and 22.2 °C (69 and 72 °F) and at any relative humidity between 10 and 70 percent for at least four hours prior to a test.

(2) Torque the jam nut (drawing 9001336) on the neck cable (drawing 210-2040) to 0.2 Nm to 0.35Nm (2 in-lb to 3 in-lb).

(3) Mount the neck-headform assembly, defined in paragraph (a) of this section, on the pendulum so the midsagittal plane of the headform is vertical and coincides with the plane of motion of the pendulum as shown in Figure P2 for flexion and Figure P3 for extension tests.

(i) The moment and rotation data channels are defined to be zero when the longitudinal centerline of the neck and pendulum are parallel.

(ii) The test shall be conducted without inducing any torsion type twisting of the neck.

(4) Release the pendulum and allow it to fall freely to achieve an impact velocity of 5.50 +/- 0.10 m/s (18.05 + 0.40 ft/s) for flexion and 3.65 +/- 0.1 m/s (11.98 +/- 0.40 ft/s) for extension tests, measured at the center of the pendulum accelerometer at the instant of contact with the honeycomb.

(i) Time-zero is defined as the time of initial contact between the pendulum striker plate and the honeycomb material. The pendulum accelerometer data channel shall be at the zero level at this time.

(ii) Stop the pendulum from the initial velocity with an acceleration vs. time pulse which meets the velocity change as specified below. Integrate the pendulum acceleration data channel to obtain the velocity vs. time curve as indicated in Table B:

TABLE B

Time ms	Flexion		Time ms	Extension	
	m/s	ft/s		m/s	ft/s
Pendulum Pulse					
10	2.0-2.7	6.6-8.9	6	1.0-1.4	3.3-4.6
15	3.0-4.0	9.8-13.1	10	1.9-2.5	6.2-8.2
20	4.0-5.1	13.1-16.7	14	2.8-3.5	9.2-11.5

§ 572.144 Thorax assembly and test procedure.

(a) Thorax assembly. The thorax consists of the part of the torso assembly shown in drawing 210-3000.

(b) When the thorax of a completely assembled dummy (drawing 210-0000) is impacted by a test probe conforming to § 572.146(a) at 6.0 +/- 0.1 m/s (19.7 +/- 0.3 ft/s) according to the test procedure in paragraph (c) of this section,

(1) Maximum sternum displacement relative to the spine, measured with the

chest deflection transducer (SA-572-S50), shall not be less than 32mm (1.3 in) and not more than 38mm (1.5in). During this displacement interval, the peak force, measured by the probe-mounted accelerometer in accordance with paragraph § 572.146(a), shall not be less than 0.6 kN (135 lb) and not more than 0.8 kN (180 lb).

(2) The internal hysteresis of the ribcage in each impact, as determined from the force vs deflection curve, shall be not less than 65 percent and not more than 85 percent.

(c) Test procedure.

(1) Soak the dummy in a controlled environment at any temperature between 20.6 and 22.2 °C (69 and 72 °F) and at any relative humidity between 10 and 70 percent for at least four hours prior to a test.

(2) Seat and orient the dummy, that wears light-weight-cotton stretch short-sleeve shirt and above-the-knee pants, on a seating surface without back support as shown in Figure P4, with the lower limbs extended horizontally and forward, the upper arms parallel to the

torso and the lower arms extended horizontally and forward all parallel to the midsagittal plane. The midsagittal plane is vertical within ± 1 degree and the posterior surface of the upper spine box is aligned at 90 ± 1 degrees from the horizontal.

(3) Establish the impact point at the chest midsagittal plane so that the impact point of the longitudinal centerline of the probe coincides with the dummy's midsagittal plane and is centered on the center of No. 2 rib within ± 2.5 mm and 0.5 degrees of a horizontal plane.

(4) Impact the thorax with the test probe so that at the moment of contact the probe's longitudinal center line falls within 2 degrees of a horizontal line in the dummy's midsagittal plane.

(5) Guide the test probe during impact so that there is no significant lateral, vertical or rotational movement.

(6) Allow at least 30 minutes between successive tests.

§ 572.145 Upper and lower torso assemblies and torso flexion test procedure.

(a) Upper/lower torso (drawing 210-3000) and upper leg assembly (drawings 210-5100-1(left) and -2(right)). The test objective is to determine the resistance of the lumbar spine and abdomen of a fully assembled dummy (drawing 210-0000) to flexion articulation between upper and lower halves of the torso assembly.

(b) When the upper half of the torso assembly of a seated dummy is subjected to a force continuously applied at the occipital condyle level through the rigidly attached adaptor bracket as shown in Figure P5 according to the test procedure set out in paragraph (c) of this section, the lumbar spine-abdomen assembly shall:

(1) Flex by an amount that permits the upper half of the torso as measured at the posterior surface of the spine accelerometer box (drawing 210-8020) to rotate in midsagittal plane 45 degrees with respect to the vertical, at which time the force level is not less than 130 N (28.8 lb) and not more than 180 N (41.2 lb), and

(2) Upon removal of the force, the upper torso assembly returns to within 10 degrees of its initial position.

(c) Test procedure. The procedure for the upper/lower torso flexion stiffness test is as follows:

(1) Soak the dummy in a controlled environment at any temperature between 20.6° and 22° C (69 and 72° F) and at any relative humidity between 10 and 70 percent for at least 4 hours prior to a test.

(2) Assemble the complete dummy (with or without the lower legs) and

position at the fixture in a seated posture as shown in Figure P5.

(i) Secure the pelvis to the fixture where the lumbar load transducer or its structural replacement bolts to the pelvis weldment (drawing 219-4510) with a rigid bracket as shown in Figure P5.

(ii) Tighten the mountings so that the pelvis-lumbar joining surface is horizontal within ± 1 deg and the dummy as seated is in contact with the test surface.

(3) Install a low weight rigid loading adapter bracket (not to exceed 0.75 kg (1.65 lb)) to the posterior surface of the upper spine box as shown in Figure P5. The loading bracket is designed such that the point of load application coincides with the level of the occipital condyle and also provides means for measuring the rotation of the upper torso.

(4) Point the upper arms vertically downward and the lower arms forward.

(5) Inspect and adjust, if necessary, the seating of the abdominal insert within the pelvis cavity.

(6) The initial orientation of the angle reference plane of the seated, unsupported dummy shall not exceed 15 degrees of flexion as shown in Figure P5. The angle reference plane is defined by the transverse plane of the posterior surface of the upper thoracic instrumentation cavity makes with respect to the vertical as shown in Figure P5.

(7) Apply a forward force in the midsagittal plane through the adaptor bracket as shown in Figure P5 at any upper torso flexion rate between 0.5 and 1.5 degrees per second, until the angle reference plane reaches 45 degrees of flexion with the applied force at 62 degrees to 65 degrees from horizontal.

(8) Continue to apply a force sufficient to maintain 45 degrees of flexion for 10 seconds, and record the highest applied force during the 10 seconds period.

(9) Release all force as rapidly as possible, and measure the return angle with respect to the initial angle reference plane as defined in paragraph (c)(7) of this section 3 minutes after the release.

§ 572.146 Test conditions and instrumentation

(a) The test probe used for thoracic impact tests is a 50.8 mm (2 in) diameter cylinder that weighs $1.7 \pm .02$ kg (3.75 lb) including instrumentation. Its impacting end has a flat right angle face that is rigid and has an edge radius of 12.7 mm (0.5 in). The test probe has an accelerometer mounted on the end opposite from impact with its sensitive

axis co-linear to the longitudinal centerline of the cylinder.

(b) Head accelerometers have the dimensions, response characteristics, and sensitive mass locations specified in drawing SA-572-S4 and are mounted in the head as shown in drawing 210-0000.

(c) The neck force-moment transducer has the dimensions, response characteristics, and sensitive axis locations specified in drawing SA-572-S19 and is mounted for testing as shown in the head-neck assembly consisting of drawing 210-0000.

(d) The shoulder force transducers have the dimensions and response characteristics specified in drawing SA-572-S21 and are allowed to be mounted as an option in the torso assembly as shown 210-0000.

(e) The thorax accelerometers have the dimensions, response characteristics, and sensitive mass locations specified in drawing SA-572-S4 and are mounted in the torso assembly in triaxial configuration at the T4 location, and as options at T1, and T12, and in uniaxial configuration on the sternum at the midpoint level of ribs 1 and 3 and on the spine coinciding with the midpoint level of #3 rib as shown in drawing 210-0000.

(f) The chest deflection potentiometer has the dimensions and response characteristics specified in drawing SA-572-50 and is mounted in the torso assembly as shown drawing 210-0000.

(g) The lumbar spine force/moment transducer has the dimensions and response characteristics specified in drawing SA-572-S20 and is allowed to be mounted as an option in the torso assembly as shown drawing 210-0000.

(h) The pubic force transducer has the dimensions and response characteristics specified in drawing SA-572-S18 and is allowed to be mounted as an option in the torso assembly as shown 210-0000.

(i) The acetabulum force transducers have the dimensions and response characteristics specified in drawing SA-572-S22 and are allowed to be mounted as options in the torso assembly as shown 210-0000.

(j) The anterior-superior iliac spine transducers have the dimensions and response characteristics specified in drawing SA-572-S17 and are allowed to be mounted as options in the torso assembly as shown drawing 210-0000.

(k) The pelvis accelerometers have the dimensions, response characteristics, and sensitive mass locations specified in drawing SA-572-S4 and are mounted within the pelvis in triaxial configuration as shown drawing 210-0000.

(l) The outputs of acceleration and force-sensing devices installed in the dummy and in the test apparatus specified by this part are recorded in individual data channels that conform to the requirements of SAE Recommended Practice J211, Mar95 "Instrumentation for Impact Tests," with channel classes as follows:

- (1) Head acceleration—Class 1000
- (2) Neck
 - (i) force—Class 1000
 - (ii) moments—Class 600
 - (iii) pendulum acceleration—Class 180
- (3) Thorax:
 - (i) rib/sternum acceleration—Class 1000

- (ii) spine and pendulum accelerations—Class 180
- (iii) Thorax deflection—Class 600
- (4) Lumbar: Forces and moments—Class 1000
- (5) Pelvis: accelerations, forces and moments—Class 1000.
- (m) Coordinate signs for instrumentation polarity conform to the Sign Convention For Vehicle Crash Testing, Surface Vehicle Information Report, SAE J1733, 1994-12.
- (n) The mountings for sensing devices shall have no resonance frequency within range of 3 times the frequency range of the applicable channel class.
- (o) Limb joints shall be set at lg, barely restraining the weight of the limb

when it is extended horizontally. The force required to move a limb segment shall not exceed 2 g throughout the range of limb motion.

(p) Performance tests of the same component, segment, assembly, or fully assembled dummy shall be separated in time by a period of not less than 30 minutes unless otherwise noted.

(q) Surfaces of dummy components are not painted except as specified in this part or in drawings subtended by this part.

BILLING CODE 4910-59-P

Figure P 1
HEAD DROP TEST SET-UP SPECIFICATIONS

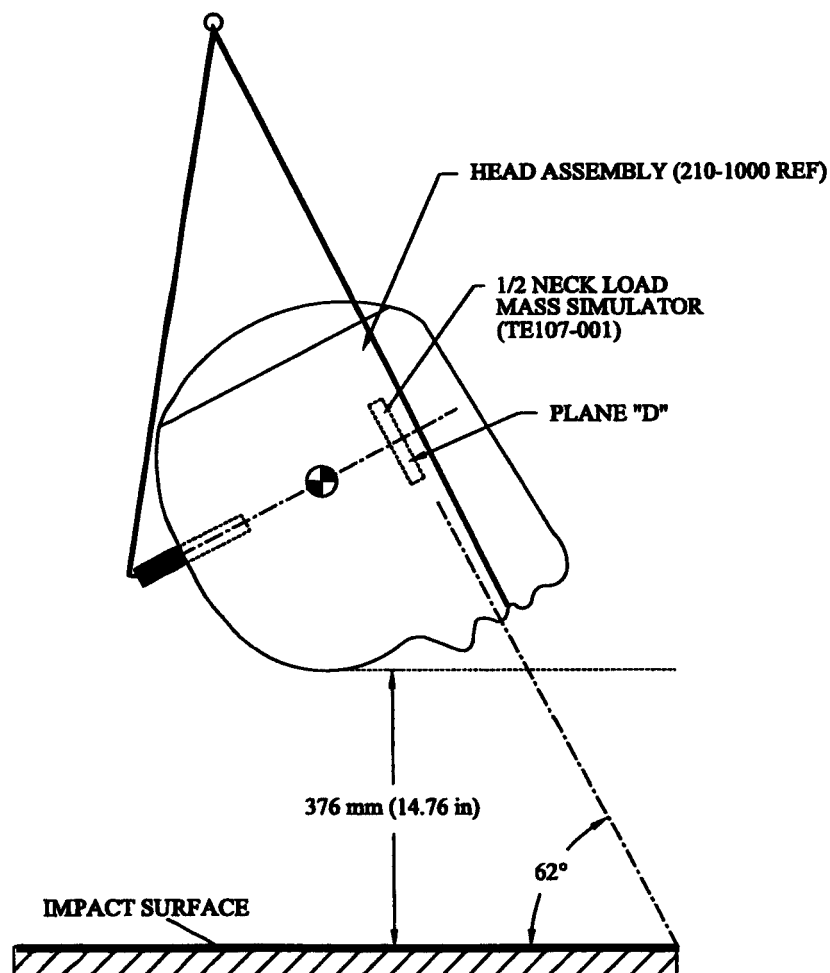
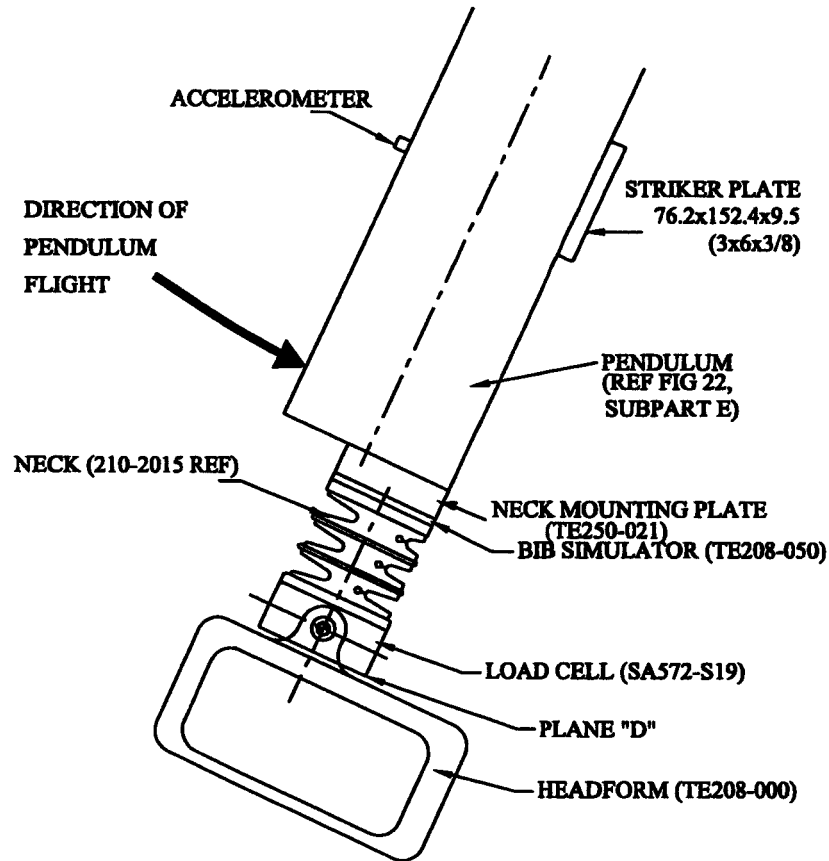
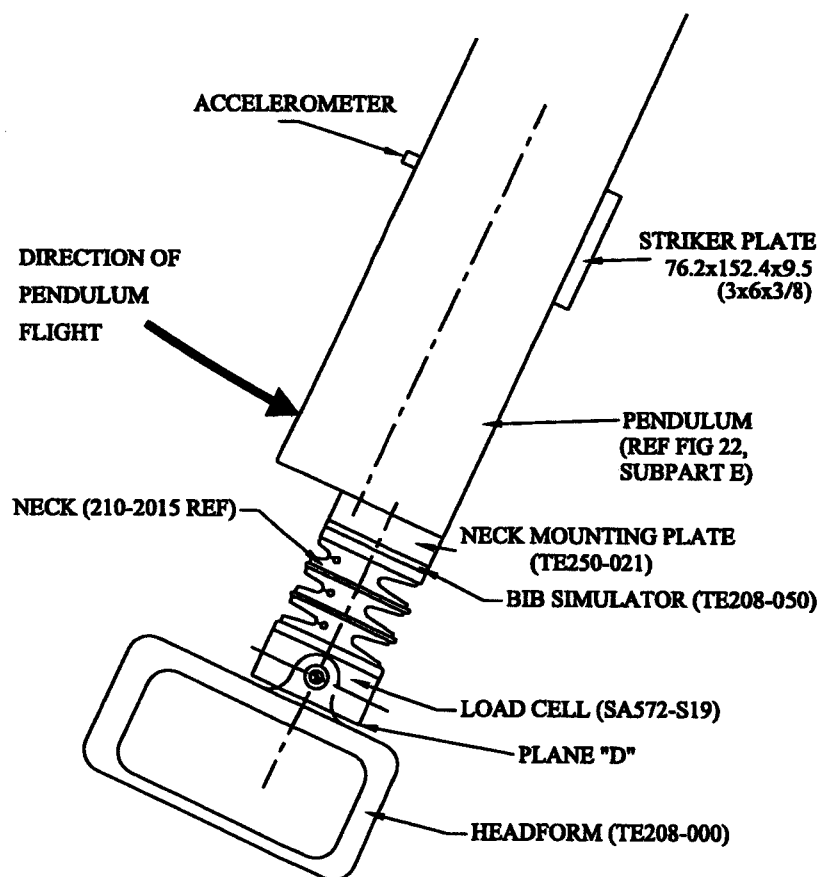

Figure P 2
NECK FLEXION TEST SET-UP SPECIFICATIONS



NOTE: MOUNT NECK AT LEADING EDGE OF PENDULUM TO AVOID INTERFERENCE WITH HEADFORM MOTION.

Figure P 3
NECK EXTENSION TEST SET-UP SPECIFICATIONS



NOTE: MOUNT NECK AT LEADING EDGE OF PENDULUM TO AVOID INTERFERENCE WITH HEADFORM MOTION.

Figure P 4
THORAX IMPACT TEST SET-UP SPECIFICATIONS

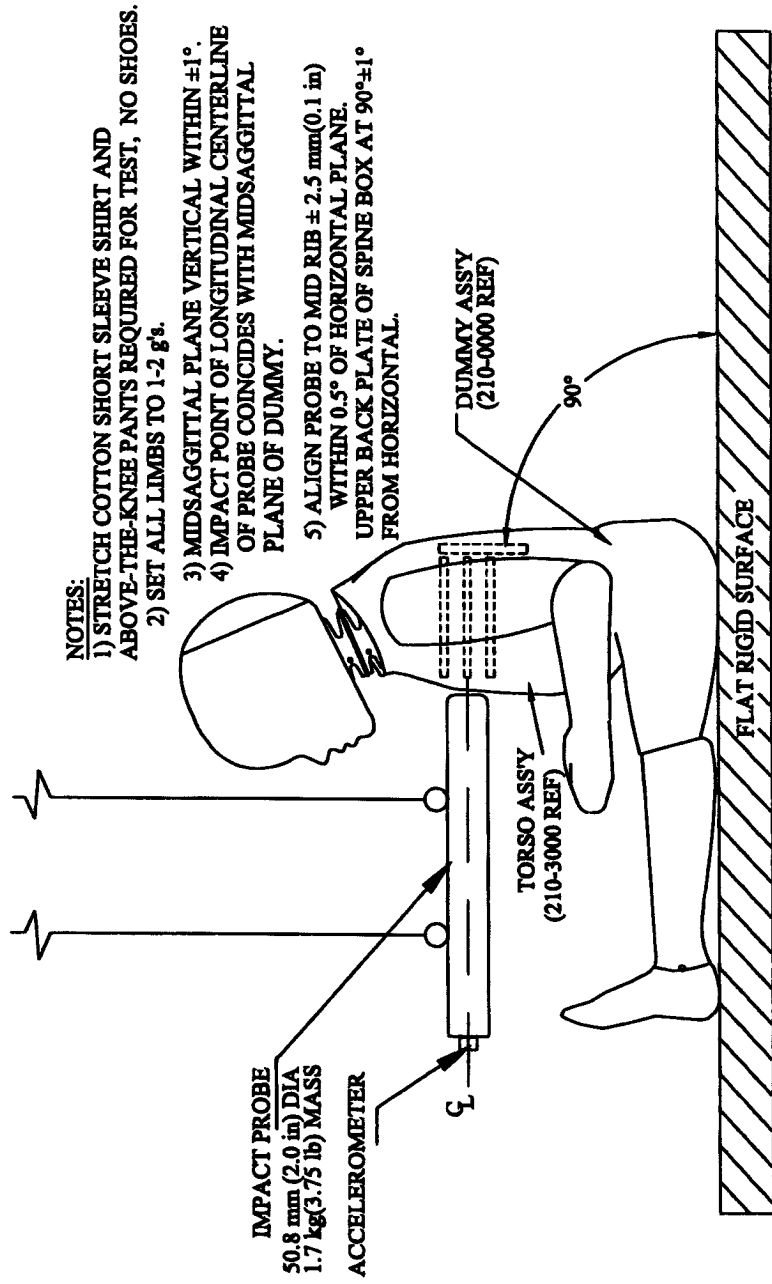

NOTES:

- 1) STRETCH COTTON SHORT SLEEVE SHIRT AND ABOVE-THE-KNEE PANTS REQUIRED FOR TEST, NO SHOES.
- 2) SET ALL LIMBS TO 1-2 g's.
- 3) MIDSAGITTAL PLANE VERTICAL WITHIN $\pm 1^\circ$.
- 4) IMPACT POINT OF LONGITUDINAL CENTERLINE OF PROBE COINCIDES WITH MIDSAGITTAL PLANE OF DUMMY.
- 5) ALIGN PROBE TO MID RIB ± 2.5 mm (0.1 in) WITHIN 0.5° OF HORIZONTAL PLANE. UPPER BACK PLATE OF SPINE BOX AT $90^\circ \pm 1^\circ$ FROM HORIZONTAL.

Figure P 5
TORSO FLEXION TEST SET-UP SPECIFICATION

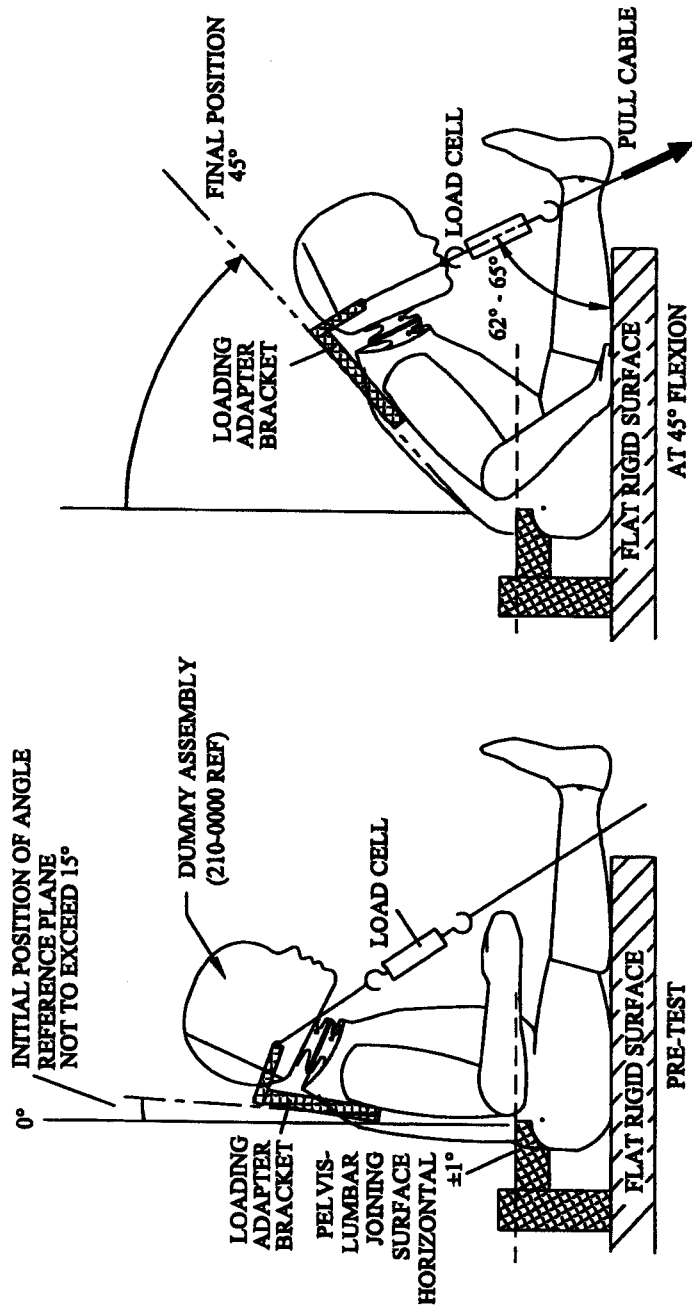

Issued on: January 22, 1999.

L. Robert Shelton,

Associate Administrator for Safety
 Performance Standards.

[FR Doc. 99-1939 Filed 1-27-99; 8:45 am]

BILLING CODE 4910-59-C