

ENVIRONMENTAL PROTECTION AGENCY

40 CFR Part 63

[AD-FRL-5636-1]

RIN 2060-AG65

National Emission Standards for Hazardous Air Pollutants and Control Techniques Guideline Document; Aerospace Manufacturing and Rework Facilities

AGENCY: Environmental Protection Agency (EPA).

ACTION: Proposed amendments to final rule and release of draft control techniques guideline (CTG) document for public review.

SUMMARY: This action proposes several amendments to the national emission standards for hazardous air pollutants (NESHAP) for aerospace manufacturing and rework facilities promulgated in the Federal Register on September 1, 1995 (60 FR 45948). This action proposes corrections to several references in the rule; revisions and additions to definitions; clarification of the applicability of the cleaning operations standards; clarification of the applicability of the rule to space vehicles; addition of standards for Type I chemical milling maskants; revision of standards for new and existing sources using dry particulate filters to control emissions from topcoat and primer application and depainting operations; addition of a test method for determining the filtration efficiency of dry particulate filters; addition of an exemption for certain water-reducible coatings; addition of an essential use exemption for cleaning solvents; clarification of compliance dates; clarification of the applicability of new source MACT to spray booth standards; clarification of the requirements for new and existing primer and topcoat application operations; clarification of monitoring requirements for dry particulate filter usage; addition of appendix A to this subpart containing definitions for specialty coatings; and addition of a cross reference to requirements in the General Provisions in subpart A of part 63.

In addition, today's document announces the availability of a draft CTG document for control of volatile organic compound (VOC) emissions from aerospace manufacturing and rework facilities for public review and comment. This document has been prepared to assist States in analyzing and determining reasonably available control technology (RACT) for

stationary sources of VOC emissions located within ozone national ambient air quality standard nonattainment areas.

DATES: *Comments.* Comments on these proposed changes and on the CTG must be received on or before December 30, 1996.

ADDRESSES: *Comments.* Interested parties may submit written comments (in duplicate, if possible) on the proposed changes to the NESHAP to: Air and Radiation Docket and Information Center (6102), (LE-131), Attention, Docket No. A-92-20, U.S. Environmental Protection Agency, 401 M Street, SW., Washington, DC 20460. Comments on the proposed changes to the NESHAP may also be submitted electronically by sending electronic mail (e-mail) to: a-and-r-docket@epamail.epa.gov. Submit comments regarding the draft CTG to Mr. James Szykman, Policy Planning and Standards Group, Emission Standards Division (MD-13), U.S. Environmental Protection Agency, Research Triangle Park, NC 27711.

Electronic comments must be submitted as an ASCII file avoiding the use of special characters and any form of encryption. Comments will also be accepted on diskette in WordPerfect 5.1 or ASCII file format. All comments in electronic form must be identified by the docket number A-92-20. No Confidential Business Information (CBI) should be submitted through e-mail. Electronic comments may be filed online at many Federal Depository Libraries.

Docket. Docket No. A-92-20, containing the proposed regulatory text, proposed Method 319, and other materials related to this rulemaking used in developing the NESHAP, is available for public inspection and copying between 8:30 a.m. to noon, and from 1 and 3 p.m., Monday through Friday, at EPA's Air and Radiation Docket and Information Center, Waterside Mall, Room M-1500, 401 M Street, SW., Washington, DC 20460; telephone (202) 260-7548. A reasonable fee may be charged for copying. The docket for the CTG is available for public inspection and copying at the Office of Air Quality Planning and Standards, Research Triangle Park, NC 27711.

Control Techniques Guideline

Copies of the draft CTG may be obtained from the U.S. EPA Library (MD-35), Research Triangle Park, NC 27711; telephone (919) 541-2777.

The proposed amendments, proposed Method 319, and CTG also are available

on the Technology Transfer Network (TTN), one of EPA's electronic bulletin boards. The service is free, except for the cost of a phone call. Dial (919) 541-5742 with a modem of up 14,400 baud per second (BPS). If more information on the TTN is needed, call the HELP line at (919) 541-5384.

FOR FURTHER INFORMATION CONTACT: For information concerning the standards or the CTG, contact Mr. James Szykman, Policy Planning and Standards Group, Emission Standards Division (MD-13), U.S. Environmental Protection Agency, Research Triangle Park, NC 27711; telephone (919) 541-2452.

SUPPLEMENTARY INFORMATION:

Regulated Entities.

Entities potentially regulated by this action are owners or operators of facilities that are engaged, either in part or in whole, in the manufacturing or rework of commercial, civil, or military aerospace vehicles or components and that are major sources as defined in § 63.2. Regulated categories include:

Category	Examples of regulated entities
Industry	Facilities which are major sources of hazardous air pollutants and manufacture, rework, or repair aircraft such as airplanes, helicopters, missiles, rockets, and space vehicles.
Federal Government.	Federal facilities which are major sources of hazardous air pollutants and manufacture, rework, or repair aircraft such as airplanes, helicopters, missiles, rockets, and space vehicles.

This table is not intended to be exhaustive, but rather provides a guide for readers regarding entities that EPA is now aware could potentially be regulated by this action. Other types of entities not listed in the table could also be regulated. To determine whether your facility [company, business, organization, etc.] is regulated by this action, you should carefully examine the applicability criteria in § 63.741 of the NESHAP for aerospace manufacturing and rework facilities promulgated in the Federal Register on September 1, 1995 (60 FR 45948).

The information presented below is organized as follows:

- I. Background
- II. Summary of and Rationale for Rule Changes
 - A. Corrections to References
 - B. Definitions
 - C. Cleaning Operations
 - D. Applicability to Space Vehicles
 - E. Standards for Type I Maskants

- F. Test Method for Determining Filtration Efficiency
- G. Standards for Dry Particulate Filters
- H. Exemption for Waterborne Coatings
- I. Essential Use Exemption for Cleaning Solvents
- J. Compliance Dates
- K. Requirements for New Affected Sources (Spray Booths)
- L. Requirements for New and Existing Primer and Topcoat Application Operations
- M. Monitoring Requirements for Dry Particulate Filter Usage
- N. Depainting Operations
- O. Applicability of General Provisions
- III. Control Techniques Guideline
- IV. Administrative Requirements
 - A. Docket
 - B. Paperwork Reduction Act
 - C. Executive Order 12866
 - D. Regulatory Flexibility Act

- E. Regulatory Review
- F. Unfunded Mandates Act

I. Background

National emission standards for hazardous air pollutants for aerospace manufacturing and rework facilities were proposed in the Federal Register on June 6, 1994 (60 FR 29216). Public comments were received regarding the standards and the final NESHAP was promulgated in the Federal Register on September 1, 1995 (60 FR 45948). This action proposes to amend §§ 63.741, 63.742, 63.743, 63.744, 63.745, 63.746, 63.747, 63.749, 63.750, 63.751, 63.752 and 63.753 of subpart GG of 40 CFR part 63. These sections deal with applicability, definitions, general standards, cleaning operations, topcoat

and primer application operations, depainting operations, chemical milling maskant application operations, compliance dates and determinations, test methods and procedures, monitoring requirements, recordkeeping requirements, and reporting requirements.

II. Summary of and Rationale for Proposed Rule Changes

Table 1, Summary of Subpart GG of 40 CFR Part 63—National Emission Standards for Aerospace Manufacturing and Rework Facilities, was included as part of the preamble when the final rule was published in the Federal Register. Because of the many proposed corrections, revisions, and additions to the final rule reflected in this notice,

TABLE 1.—SUMMARY OF SUBPART GG OF 40 CFR PART 63—NATIONAL EMISSION STANDARDS FOR AEROSPACE MANUFACTURING AND REWORK FACILITIES

Affected source	Requirement	Description
Aerospace Facilities	Applicability: General Information	This rule applies to facilities engaged in original equipment manufacture and/or rework of aerospace vehicles components and assemblies and that are major sources as defined in 40 CFR part 63. Specific operations are covered by the rule. (63.741)
	Estimated Number of Facilities ...	Over 2,800 facilities are expected to be affected by the rule. Applicable SIC codes include 3720, 3721, 3724, 3728, 3760, 3761, 3764, 3765, and 4581.
	Permit Requirements	Major sources required to obtain operating permit in State where facility is located according to procedures in 40 CFR part 70 and applicable State regulations. (63.741(d))
All Affected Sources	Standards	<ol style="list-style-type: none"> 1. Comply with § 63.4 through § 63.6 of the General Provisions of 40 CFR part 63, subpart A, except as provided in Table 3.^a (63.743(a)) 2. Submit a startup, shutdown, and malfunction plan, except for new sources or filter systems operated per manufacturer's instructions. (63.743(b)) 3. Obtain approval to use control device not listed in this subpart. (63.743(c)) 4. Wastes subject to RCRA are exempt from the requirements of this subpart. (63.741(e))
	Compliance Dates	As provided for in the General Provisions, within 3 years after the effective date for existing sources and no later than the standards' effective date or upon startup, as appropriate, for new and reconstructed sources. (63.749(a))
	Test Methods and Procedures	See individual affected sources. Also, comply with § 63.7 of the General Provisions. (63.749 & 63.750)
	Monitoring Requirements	See individual affected sources. Also, generally same as in § 63.8 (f) and (g) of the General Provisions. (63.751 (e) and (f))
	Recordkeeping Requirements	Comply with certain parts of § 63.10 of the General Provisions. (63.752(a))
	Reporting Requirements	<ol style="list-style-type: none"> 1. See individual affected sources. Comply with certain parts of § 63.9 and § 63.10 of the General Provisions, except as specified in). 2. Operating permit application can be used for initial notification. (63.753(a)(2))
	Cleaning Operations	Standards
Test Methods and Procedures		See individual affected sources.
Monitoring Requirements		See individual affected sources.
	Recordkeeping Requirements	The name and vapor pressure of each cleaning solvent, and supporting documentation. (63.752(b)(1))

TABLE 1.—SUMMARY OF SUBPART GG OF 40 CFR PART 63—NATIONAL EMISSION STANDARDS FOR AEROSPACE MANUFACTURING AND REWORK FACILITIES—Continued

Affected source	Requirement	Description
Hand-Wipe Cleaning Operations	Standards	1. Except for spray gun and flush cleaning, all HAP or VOC hand-wipe cleaning solvents must meet a composition requirement, have a vapor pressure less than or equal to 45 mm Hg at 20°C, or meet the requirements specified in an alternative compliance plan administered by the permitting authority and approved under Section 112(l) of the Clean Air Act. (63.744(b)) 2. List of cleaning operations exempt from composition and vapor pressure requirements. (63.744(e))
	Test Methods and Procedures	1. Composition determination through manufacturer's data. (63.750(a)) 2. Vapor pressure determination through readily available sources if single component; ASTM E 260–85 and composite vapor pressure determination procedure for multiple component solvents. (63.750(b))
	Monitoring Requirements	None.
	Recordkeeping Requirements	1. If complying with composition requirements, name, data/calculations, and annual volumes. (63.752(b)(2)) 2. If complying with vapor pressure limit, the name, vapor pressure, data/calculations/test results, and monthly volumes. (63.752(b)(3)) 3. For noncompliant cleaning solvents used in exempt operations, monthly volumes by operation, and master list of processes. (63.752(b)(4))
	Reporting Requirements	<i>Semiannual</i> 1. Noncompliant cleaning solvent usage. (63.753(b)(1)(i)) 2. New cleaning solvents and vapor pressure or composition. (63.753(b)(1)(ii)) 3. Statement certifying everything is in compliance. (63.753(b)(1)(v))
Spray Gun Cleaning	Standards	1. Use one of four specified techniques or an equivalent. (63.744(c)) 2. For enclosed spray gun cleaners, repair as soon as practicable, but within 15 days. (63.744(c)(1)(ii))
	Test Methods and Procedures	None.
	Monitoring Requirements	Visual inspection for leaks at least once per month. (63.751(a))
	Recordkeeping Requirements	Record all leaks, including source identification and dates leaks found and repaired. (63.752(b)(5))
	Reporting Requirements	<i>Semiannual</i> 1. Noncompliant spray gun cleaning method used. (63.753(b)(1)(iii)) 2. Leaks of enclosed spray gun cleaners not repaired within 15 days of detection. (63.753(b)(1)(iv)) 3. Statement certifying everything is in compliance. (63.753(b)(1)(v))
Flush Cleaning	Standards	Operating procedures specify emptying into enclosed container, collection system, or equivalent. (63.744(d))
	Test Methods and Procedures	None.
	Monitoring Requirements	None.
	Recordkeeping Requirements	None.
	Reporting Requirements	<i>Semiannual</i>
Primer and Topcoat Application Operations.	Standards	Statement certifying everything is in compliance. (63.753(b)(1)(v)) Minimize spills during handling and transfer. (63.745(b)) <i>Uncontrolled Primers</i> 1. Organic HAP content limit: 350 g/l (2.9 lb/gal) (less water) as applied. (63.745(c)(1)) 2. VOC content limit: 350 g/l (2.9 lb/gal) (less water and exempt solvents) as applied. (63.745(c)(2)) 3. Achieve compliance through: (1) use coatings below content limits, or (2) use monthly volume-weighted averaging to meet content limits. (63.745(e)) <i>Uncontrolled Topcoats</i> 4. Organic HAP content limit: 420 g/l (3.5 lb/gal)(less water) as applied. (63.745(c)(3)) 5. VOC content limit: 420 g/l (3.5 lb/gal) (less water and exempt solvents). (63.745(c)(4)). 6. Achieve compliance as in 3. above. (63.745(e)) <i>Controlled Primers and Topcoats</i> 7. If control system is used, must be designed to capture and control all emissions from the application operation and must achieve an overall control efficiency of at least 81%. (63.745(d)) <i>All Primers and Topcoats</i> 8. Specific application techniques must be used. If alternative is sought, can only be used if emissions are less than or equal to HVLP or electrostatic spray application techniques. (63.745(f)(1)) 9. All application equipment must be operated according to manufacturer's specifications, company procedures, or locally specified operating procedures. (63.745(f)(2))

TABLE 1.—SUMMARY OF SUBPART GG OF 40 CFR PART 63—NATIONAL EMISSION STANDARDS FOR AEROSPACE MANUFACTURING AND REWORK FACILITIES—Continued

Affected source	Requirement	Description
	Performance Test Periods and Tests. Test Methods and Procedures Monitoring Requirements Recordkeeping Requirements Reporting Requirements	10. Exemptions from No. 8 above provided for in certain situations. (63.745(f)(3)) 11. Operating requirements for the application of primers or topcoats that contain inorganic HAP, including control with either particulate filters or waterwash, and shutdown if operated outside manufacturer's specified limits. (63.745(g) (1) through (3)) 12. Exemptions from No. 11 provided for certain application operations. (63.745(g)(4)) 1. For "compliant" coatings: each 30-day period. For "averaged" coatings: each 30-day period. For "controlled" coatings, noncarbon adsorber: three 1-hour runs. For "controlled" coatings, carbon adsorber: each rolling material balance period. (63.749(d)(1)) 2. Initial performance test for all control devices to demonstrate compliance with overall control efficiency requirement. (63.749(e)(2)) 1. Organic HAP level determination procedures. (63.750 (c) and (d)) 2. VOC level determination procedures. (63.750 (e) and (f)) 3. Overall control efficiency of carbon adsorber system determined using provided procedures; for other control devices, determine capture efficiency and destruction efficiency. For capture efficiency, use Procedure T in Appendix B to 40 CFR 52.741 for total enclosures and 40 CFR 52.741(a)(4)(iii) procedures for all other enclosures. (63.750 (g) and (h)) 4. For alternative application methods, first determine emission levels for initial 30-day period or five aircraft using only HVLP or electrostatic, or a time period specified by the permitting agency. Then use alternative application method for period of time necessary to coat equivalent amount of parts with same coatings. Alternative application method may be used when emissions generated during the test period are less than or equal to the emissions generated during the initial 30-day period or five aircraft. Dried film thickness must be within specification for initial 30-day period or five aircraft as demonstrated under actual production conditions. (63.750(i)) 1. Temperature sensors with continuous recorders for incinerators, and install, calibrate, maintain, and operate temperature monitors according to manufacturer's specifications. Use CEMS as an alternative. (63.751(b)) 2. Continuously monitor pressure drop across filter; read and record pressure drop or water flow rate through waterwash once per shift. (63.751(c)) 1. Name and VOC content for all primers and topcoats. If coating contains exempt solvents, calculate total HAP content. (63.752(c)(1)) 2. For "compliant" coatings, organic HAP and VOC contents as applied, data/calculations or Method 24 used to determine them, and monthly usage. (63.752(c)(2)) 3. For "low-HAP/VOC" primers, annual purchase records, and data/calculations or Method 24 used to determine H. (63.752(c)(3)) 4. For "averaged" coatings, monthly values of VOC content (H_a and G_a), and data/calculations or Method 24 used to calculate H_a and G_a . (63.752(c)(4)) 5. For "controlled" coatings (incinerator), overall control efficiency and incinerator temperature(s). (63.752(c)(5)) 6. For "controlled" coatings (carbon adsorber), overall control efficiency and length of rolling period and all supporting data/calculations. (63.752(c)(6)) 7. Pressure drop across filter or water flow rate through waterwash once per shift, and acceptable limits. (63.752(d) (1) through (3)) <i>Semiannual</i> 1. All instances where organic HAP/VOC limits were exceeded. (63.753(c)(1) (i) and (ii)) 2. Control device exceedances (out-of-compliance). (63.753(c)(1) (iii), (iv), and (v)) 3. Periods when operation not immediately shut down due to pressure drop or water flow rate being outside limits. (63.753(c)(1)(vi)) 4. Statement certifying everything is in compliance. (63.753(c)(vii)) <i>Annual</i> 5. Number of times the pressure drop or water flow rate limits were exceeded. (63.753(c)(2))

TABLE 1.—SUMMARY OF SUBPART GG OF 40 CFR PART 63—NATIONAL EMISSION STANDARDS FOR AEROSPACE MANUFACTURING AND REWORK FACILITIES—Continued

Affected source	Requirement	Description
Depainting Operations	Applicability	Applies to the outer surface of aerospace vehicles. Does not apply to parts or units normally removed. Fuselage, wings, and stabilizers always covered. Radomes, parts normally removed are exempt. (63.746(a))
	Standards	<ol style="list-style-type: none"> 1. Unless exempted, no organic HAP are to be emitted from chemical strippers or softeners. (63.746(b)(1)) 2. Minimize inorganic HAP emissions during periods of nonchemical based equipment malfunction. (63.746(b)(2)) 3. Use of organic HAP material(s) for spot stripping and decal removal limited to 190 pounds per aircraft per year for commercial aircraft and 365 pounds per aircraft per year for military aircraft. (63.746(b)(3)) 4. Operating requirements for depainting operations generating airborne inorganic HAP, including control with particulate filters or waterwash systems. Mechanical and hand sanding are exempt. (63.746(b)(4) and (b)(5)) 5. Nonexempt organic HAP emissions controlled at 81% efficiency for systems installed before effective date. For newer systems, control at 95%. (63.746(c))
	Performance Test Periods and Tests.	<ol style="list-style-type: none"> 1. For demonstrating no organic HAP emissions: each 24-hour period. (63.749(f)(1)) 2. For spot stripping and decal removal usage limits: each calendar year. (63.749(f)(1)) 3. Initial performance test for all control devices to demonstrate compliance with overall control efficiency requirement. (63.749(f)(1), (f)(2), and (f)(3))
	Test Methods and Procedures	<ol style="list-style-type: none"> 1. Procedures provided for determining pounds of organic HAP material(s) used for aircraft. (63.750(j)) 2. Overall control efficiency of carbon adsorber system determined using specified procedures; for other control devices, determine capture efficiency and destruction efficiency. For capture efficiency, use Procedure T in Appendix B to 40 CFR 52.741 for total enclosures and 40 CFR 52.741(a)(4)(iii) procedures for all other enclosures. (63.750(g) and (h))
	Monitoring Requirements	Continuously monitor pressure drop across filter; read and record pressure drop or water flow rate through waterwash once per shift. (63.751(d))
	Recordkeeping Requirements	<ol style="list-style-type: none"> 1. Name and monthly usage (weight) of all organic HAP material(s) used in chemical strippers. (63.752(e)(1)) 2. For controlled chemical strippers (carbon adsorber), overall control efficiency and length of rolling period and all supporting data/calculations. (63.752(e)(2)) 3. For controlled chemical strippers (other control devices), overall control efficiency and supporting documentation. (63.752(e)(3)) 4. List of parts/assemblies normally removed. (63.752(e)(4)) 5. For nonchemical based equipment, name and type, and malfunction information including dates, description, and alternative methods used. (63.752(e)(5)) 6. For spot stripping and decal removal, annual volume used, annual average volume per aircraft, and all data/calculations used to calculate volume per aircraft. (63.752(e)(6)) 7. Pressure drop across filter or water flow rate through waterwash once per shift and acceptable limits. (63.752(e)(7))
	Reporting Requirements	<p><i>Semiannual</i></p> <ol style="list-style-type: none"> 1. 24-hour periods where organic HAP were emitted from depainting operations in violation of rule. (63.753(d)(1)(i)) 2. New and reformulated chemical strippers and HAP contents. (63.753(d)(1)(ii), (iii), and (iv)) 3. New non-chemical based depainting techniques. (63.753(d)(1)(v)) 4. Malfunction information on non-chemical based techniques including dates, description, and alternative methods used. (63.753(d)(1)(vi)) 5. Periods when operation not immediately shut down due to pressure drop or water flow rate being outside limits. (63.753(d)(1)(vii)) 6. List of new/discontinued aircraft models and, for new models, list of parts normally removed for depainting. (63.753(d)(1)(viii)) 7. Organic HAP control device exceedances. (63.753(d)(3)) 8. Statement certifying everything is in compliance. (63.753(d)(1)(ix)) <p><i>Annual</i></p> <ol style="list-style-type: none"> 9. Exceedances of average annual volume limits for spot stripping and decal removal. (63.753(d)(2)(i))

TABLE 1.—SUMMARY OF SUBPART GG OF 40 CFR PART 63—NATIONAL EMISSION STANDARDS FOR AEROSPACE MANUFACTURING AND REWORK FACILITIES—Continued

Affected source	Requirement	Description
Waste Handling and Storage Operations.	Applicability	10. Number of times the pressure drop or water flow rate limits were exceeded. (63.753(d)(2)(ii)) Applies only to chemical milling maskant operations with Type I or II chemical milling maskants. (63.747(a))
	Standards	Minimize spills during handling and transfer. (63.747(b)) <i>Uncontrolled Maskants</i> 1. Organic HAP emissions: 622 g/l (5.2 lb/gal) (less water) as applied for Type I, ≤ 160 g/l (1.3 lb/gal) (less water) as applied for Type II. (63.747(c)(1)) 2. VOC emissions: 622 g/l (5.2 lb/gal) (less water and exempt solvents) as applied for Type I, ≤ 160 g/l (1.3 lb/gal) (less water and exempt solvents) as applied for Type II. (63.747(c)(2)) 3. Achieve compliance through: (1) use maskants below content limits, or (2) use monthly volume-weighted averaging to meet content limits. (63.747(e)) <i>Controlled Maskants</i> 4. If control device is used, system must be designed to capture and control all emissions from maskant operation and must achieve an overall control efficiency of at least 81% for systems installed before effective date. For newer systems, control at 95%. (63.747(d))
	Performance Test Periods and Tests.	1. For compliant maskants: each 30-day period. For averaged maskants: each 30-day period. For controlled coatings, carbon adsorber: each rolling period. For controlled coatings, noncarbon adsorber: three 1-hour runs. (63.749(h)(1)) 2. Initial performance test required for all control devices to demonstrate compliance with overall control efficiency requirement. (63.749(h)(2) and (h)(3))
	Test Methods and Procedures	Procedures provided essentially identical to those for primers and topcoats for organic HAP and VOC content levels. (63.750(g), (h), and (l)-(o))
	Monitoring Requirements	Same as for primers and topcoats if incinerators are used. (63.751(b))
	Recordkeeping Requirements	Same as for primers and topcoats. (63.752(f))
	Reporting Requirements	<i>Semiannual</i> 1. Exceedances of organic HAP/VOC limits. (63.753(e)(1), (2) and (7)) 2. Control device exceedances (out of compliance). (63.753(e)(3)) 3. New maskants. (63.753(e)(4)) 4. New control devices. (63.753(e)(5)) 5. Everything is in compliance. (63.753(e)(6))
	Standards	Minimize spills during handling and transfer. (63.748)
	Test Methods and Procedures	None.
	Monitoring Requirements	None.
Recordkeeping Requirements	None.	
Reporting Requirements	None.	

^a The EPA promulgated regulations for subpart A of 40 CFR part 63, which were published in the FEDERAL REGISTER on March 16, 1994 at 59 FR 12408.

Table 1 has been revised and is included as a reference summary of the revised standards.

A. Corrections to References

In the promulgated rule, there were several references to § 63.751(b)(7), which only existed in an earlier draft of the standard. The EPA proposes the following revisions: § 63.751(b)(6)(ii)(A) of the promulgated rule references (b)(7)(iii)(A)(3), but should reference paragraph (b)(6)(iii)(A)(2); § 63.751(b)(6)(iii) references (b)(7)(iii)(A), and (b)(7)(iii)(B) or (C), but should reference paragraphs (b)(6)(iii)(A), and (b)(6)(iii)(B) or (C); § 63.751(b)(6)(iii)(A)(2) references (b)(7)(iii)(A)(1), but should reference paragraph (b)(6)(iii)(A)(1);

§ 63.751(b)(6)(iii)(D) references (b)(7)(iii)(B) or (C), but should reference paragraph (b)(6)(iii)(B) or (C).

B. Definitions

The EPA proposes that several definitions should be added to § 63.742 and several should be revised, based on additional information submitted to the Agency after promulgation of the final rule. The EPA proposes to clarify the definition of cleaning solvent because many aqueous cleaners may contain negligible amounts of HAP and VOC. In the promulgated rule, the definition of cleaning solvent states that cleaning solvents do not include "solutions that contain no HAP and VOC." The EPA proposes revising the definition as follows:

Cleaning solvent means a liquid material used for hand-wipe, spray gun, or flush cleaning. This definition does not include solutions that contain HAP or VOC below the de minimis levels specified in § 63.741(f) (e.g., water or acetone).

Based on additional information received from industry, the EPA proposes to change the definition of aircraft transparency. As promulgated, the definition is limited to the aircraft windshield. On a fighter aircraft, the windshield is only one component of the entire canopy. On a commercial aircraft, passenger windows are constructed of similar transparent materials as those used for the windshield. Also, many aircraft transparencies are not laminated, but are monolithic transparent materials.

The EPA proposes the following definition for aircraft transparency:

Aircraft transparency means the aircraft windshield, canopy, passenger windows, lenses, and other components that are constructed of transparent materials.

The Agency proposes to add a new definition of closed-cycle depainting system as follows:

Closed-cycle depainting system means a dust free, automated process that removes permanent coating in small sections at a time, and maintains a continuous vacuum around the area(s) being depainted to capture emissions.

The Agency is proposing this definition and is proposing an exemption from the total enclosure requirements found in § 63.746(b) for users of this emerging technology that encloses the area to be depainted and maintains a vacuum to capture all emissions. Captured emissions are then separated/filtered/treated and the resulting solid waste material is then appropriately disposed.

With these proposed requirements, the Agency intends to provide owners or operators of affected sources with the flexibility to use this emerging technology for depainting operations, while not penalizing the owner or operator by requiring the unnecessary enclosure of the vehicle or component being depainted.

The EPA proposes to change the definition of high volume low pressure (HVLP) spray equipment as follows:

High volume low pressure (HVLP) spray equipment means spray equipment that is used to apply coating by means of a spray gun that operates at 10.0 psig of atomizing air pressure or less at the air cap.

This change eliminates the 100 psig fluid delivery pressure specified in the final rule, since new technology has demonstrated that this requirement does not have to be met in order to ensure adequate transfer efficiency.

The EPA also proposes adding a definition of waterborne (water-reducible) coating as follows:

Waterborne (water-reducible) coating means any coating that contains more than 5 percent water by weight as applied in its volatile fraction.

The Agency has added and used this definition to encourage the use of water-reducible coatings (i.e., coatings that inherently result in lower organic HAP and VOC emissions). See Section H for additional information on exemption(s) of waterborne coatings.

The Agency also proposes adding a definition for antique aerospace vehicle or component so that these vehicles and components may be exempted from the regulation. It was never the Agency's

intent to require compliance for rework operations associated with antique aerospace vehicles or components including vintage aircraft or historical museum collections. The Agency agrees with members of the general aviation community that antique aerospace vehicles or components (i.e., aerospace vehicles or components more than 30 years old) present significant compliance challenges. Among these challenges are the difficulties in obtaining modifications to maintenance specifications (required if changes in coating or depainting operations are to be made) from manufacturing companies that are frequently no longer in operation. Another factor is the historical significance of maintaining the original integrity of the vehicle or component. In exempting these vehicles and components, the Agency proposes to adopt the definition of antique aircraft as defined in 14 CFR part 45 and limit the scope of this exemption to those vehicles or components that are not routinely in commercial service in the capacity for which they were designed. The Agency's intent in limiting this exemption is to require compliance for aerospace vehicles or components that may meet the age requirement but are still in routine commercial or military operation. The Agency also notes that this exemption would not apply to an airframe that may be more than 30 years old, but has been rebuilt and is still in routine commercial or military service in the capacity for which it was originally built.

The EPA also proposes revising the definition of specialty coating by adding a sentence that states, "Individual specialty coatings are defined in appendix A to this subpart and in the CTG for Aerospace Manufacturing and Rework Operations." This addition will allow affected owners or operators to easily identify which coatings are considered specialty coatings and are therefore exempt from this standard. The CTG also contains VOC limits for the specialty coatings defined in appendix A; appendix B (now redesignated as appendix A to this subpart) was referenced in § 63.743(a) of the final rule, but inadvertently omitted from the Federal Register publication of the final rule.

In appendix A to this subpart, the EPA proposes to revise the last sentence of the definition of adhesive bonding primer to state, "There are two categories of adhesive bonding primers: primers with a design cure at 250°F or below, and primers with a design cure above 250°F." This revision is a clarification that was omitted in the final rule.

C. Cleaning Operations

Under the promulgated rule, the standards for cleaning operations could be read to apply to all cleaning operations at a facility, not only to cleaning operations that involve aerospace vehicles, components, or coating equipment. In order to clarify the applicability of the standards for cleaning operations, the Agency proposes to limit the applicability of the final rule only to the manufacture or rework of aerospace vehicles or components. Other, non-aerospace activities are not subject to the requirements of this rule.

However, the owner or operator of a facility is not restricted from voluntarily extending to other operations the use of cleaning solvents which comply with the requirements of these NESHAP, where it is determined that such use is technologically feasible. For example, it might simplify purchasing, recordkeeping, or employee training, if the same hand-wipe cleaning solvents are used for several or all operations at a facility.

The EPA proposes replacing the word "solvent" with the defined term "cleaning solvent" for clarity and consistency in § 63.744, paragraphs (a), (b), (c), and (e).

The EPA also proposes a change to the cleaning rag storage requirement. The EPA proposes rewording the first sentence of § 63.744(a)(1) as follows:

Place cleaning solvent-laden cloth, paper, or any other absorbent applicators used for cleaning in bags or other closed containers upon completing their use.

The promulgated NESHAP requires that cleaning rags be stored immediately after use. The word "immediately" is being removed from the sentence to make the rule more consistent from a temporal standpoint with the storage requirements contained in the California SIP-approved rules that were the basis for this requirement.

Section 63.744(a)(1) of the promulgated rule also requires subject facilities to "[u]se bags and containers of such design so as to contain vapors of the cleaning solvent." It has been brought to the Agency's attention that a literal interpretation of this language means 100 percent capture efficiency, and even the most effective rag storage containers currently in use in the industry do not guarantee 100 percent capture of cleaning solvent vapors. The Agency did not intend such a literal interpretation of this requirement. The quoted language is intended to be implemented as a work practice standard, not as an absolute prohibition on emissions from rag containers. An

example of the type of container contemplated by this language would be a rigid container constructed of impermeable material and using a tight-fitting lid, such as a 55-gallon drum with a fitted lid. Such a container would satisfy this requirement even though it cannot guarantee 100-percent capture efficiency.

In addition, the EPA proposes changing the requirements for flush cleaning to cover the situation where an operator is cleaning multiple items at the same station, without leaving the station. The proposed change to § 63.744(d) is as follows: “* * * empty the used cleaning solvent each time aerospace parts or assemblies, or components of a coating unit (with the exception of spray guns) are flush cleaned * * *.” This change will better address the Agency’s intent in regulating flush cleaning.

Based on information from industry, the EPA proposes a modification to the exemption in § 63.744(e)(10). This exemption was intended to address windshield and canopy cleaning; however, many of the older canopies in service are constructed of acrylic, rather than polycarbonate. The Agency notes that acrylic canopies have the same critical cleaning requirements as the polycarbonate canopies, and believes that they therefore fall within this exemption as follows:

Cleaning of aircraft transparencies, polycarbonate, or glass substrates.

D. Applicability to Space Vehicles

Space vehicles (i.e., vehicles designed to travel beyond the limit of the earth’s atmosphere) are specifically exempted from the requirements of this rule, except for the standards for depainting operations. The EPA proposes removing the reference to these vehicles in § 63.741(f) and adding an additional specific exemption in a new paragraph, § 63.741(h), to clarify the exemption. The EPA proposes § 63.741(h) as follows:

Regulated activities associated with space vehicles designed to travel beyond the limit of the earth’s atmosphere, including but not limited to satellites, space stations, and the Space Shuttle System (including orbiter, external tanks, and solid rocket boosters), are exempt from the requirements of this subpart, except for depainting operations found in § 63.746.

E. Standards for Type I Maskants

The EPA proposes to establish an emission limitation for Type I maskants and to include Type I maskants within

the definition of chemical milling maskants.

Pursuant to section 114 of the Clean Air Act (Act), information regarding maskants was requested from nine companies that own or operate aerospace manufacturing and rework facilities. Information was requested for all types of maskants, including total quantity used, formulation data, VOC and organic HAP content as received and as applied, substrate category and the composition of the metal alloy on which the maskant is applied, a listing of the type of parts or specific aircraft surfaces on which the maskant is used, VOC and HAP emissions from maskant application operations, and type(s) of controls (if any). The information received on Type I maskants was used to calculate a MACT floor. The MACT floor was determined to be the weighted (by usage volume) average HAP emissions from the sources, 622 grams per liter [g/L] (5.2 pounds per gallon [lb/gal]).

The EPA proposes revising § 63.747(c) to include organic HAP and VOC content limits of 622 g/L (5.2 lb/gal) as the standard for uncontrolled Type I chemical milling maskants. The EPA proposes revising paragraphs (c)(1) and (2) to specify that the organic HAP and VOC limits of 160 g/L (1.3 lb/gal) apply only to Type II chemical milling maskants.

Due to the proposed addition of a standard for Type I chemical milling maskants, EPA also proposes removing the definition of Type I maskants from the list of specialty coatings in appendix A of this subpart and revising the definition for chemical milling maskant in § 63.742 of the promulgated rule to read as follows:

Chemical milling maskant means a coating that is applied directly to aluminum components to protect surface areas when chemical milling the component with a Type I or Type II etchant. This does not include bonding maskants, line sealers, and critical use and seal coat maskants. Additionally, maskants that must be used on an individual part or subassembly with a combination of Type I or Type II etchants and any of the above types of maskants (e.g., bonding, line sealers, and critical use and seal coat) are also exempt from this subpart.

The EPA also proposes revising the definition for chemical milling maskant application operations in § 63.742 to “application of chemical milling maskant for use with Type I or Type II chemical milling etchants.” The EPA specifically requests comments on the development of the MACT floor for

Type I chemical milling maskants (Docket No. A-92-20).

F. Test Method for Determining Filtration Efficiency

The Agency is proposing a test method, test Method 319, for the determination of filtration efficiency for paint overspray arrestors (also referred to as particulate filters). The Agency is proposing that this method be used by filter manufacturers to certify the efficiency of their filters for meeting the dry particulate filter requirements also being proposed in today’s amendments.

The filter efficiency tables (Tables 1, 2, 3, and 4 of § 63.745) were developed from testing conducted in November, 1995 to determine the fractional filtration efficiency of high efficiency two- and three-stage, liquid- and solid-phase particulate filters, also referred to as paint overspray arrestors. The tests also developed a filtration efficiency test method for use in certifying filters to be used by owners or operators in complying with the aerospace NESHAP.

The EPA specifically requests comments on the proposed test method for certifying the filtration efficiency for these dry particulate filters.

G. Standards for Dry Particulate Filters

The Agency is proposing revised MACT requirements for the control of inorganic particulates from certain primer, topcoat, and depainting operations. Pursuant to section 114 of the Act, information regarding particulate filters was requested from nine companies that own or operate aerospace manufacturing and rework facilities. Information was requested for all types of particulate filters, including filter manufacturer, manufacturer’s part number, number of stages, type of operation being controlled (topcoat or primer operation, dry media blasting operation, or other), installation date, filter construction/structure/composition, and control efficiency (with supporting information).

TABLE 1 OF § 63.745 TWO-STAGE ARRESTOR; LIQUID PHASE CHALLENGE

Filtration efficiency requirement, %	Aero-dynamic particle size range, μ
>90	>5.7
>50	>4.1
>10	>2.2

TABLE 2 OF § 63.745 TWO-STAGE ARRESTOR; LIQUID PHASE CHALLENGE

Filtration efficiency requirement, %	Aero-dynamic particle size range, μ
>90	>8.1
>50	>5.0
>10	>2.6

TABLE 3 OF § 63.745 TWO-STAGE ARRESTOR; LIQUID PHASE CHALLENGE

Filtration efficiency requirement, %	Aero-dynamic particle size range, μ
>95	>2.0
>80	>1.0
>65	>0.42

TABLE 4 OF § 63.745 TWO-STAGE ARRESTOR; LIQUID PHASE CHALLENGE

Filtration efficiency requirement, %	Aero-dynamic particle size range, μ
>95	>2.5
>85	>1.1
>75	>0.70

For topcoat and primer operations, information was received on 510 booths with particulate filter controls. For dry media blasting (depainting) operations, information was received on 22 booths with particulate filter controls. Based on a review of the available data, the EPA proposes requiring existing sources using particulate filters in depainting as well as topcoat and primer operations, in which any of the coatings contain inorganic HAP, to meet the filtration efficiency established for the two-stage system that was tested. Specifically, the Agency proposes requiring owners or operators of existing sources to use particulate filters that are certified by the filter manufacturer to meet or exceed the efficiency data in Tables 1 and 2 of § 63.745 (developed from the two-stage filter testing).

The Agency is also proposing that new sources meet the filtration efficiency data points for the three-stage system that was tested. Specifically, the Agency proposes requiring owners or operators of new sources to use particulate filters that are certified by the filter manufacturer to meet or exceed the efficiency data in Tables 3 and 4 of § 63.745 (developed from the three-stage filter testing). The Agency

believes that proposed performance based control efficiency requirements for particulate filters used in painting and depainting operations will give owners and operators greater flexibility in selecting their particulate filter system and will not preclude the use of new, high-efficiency filtration technologies or very high efficiency one-stage filters that may be developed in the future. The EPA specifically requests comments on these proposed standards for particulate filters used in topcoat and primer application and dry media blasting (depainting) operations.

In announcing these revised MACT requirements for particulate emissions, the Agency realizes that there are unique circumstances where owners and operators who have commenced construction or reconstruction of a new spray booth or hangar after the proposed regulation and have had to comply with the requirements in the promulgated rule. For these situations, the Agency has provided these owners or operators of aerospace manufacturing or rework operations who have commenced construction or reconstruction of new spray booth or hangar for depainting operations, primer, or topcoat operations, in which any of the coatings contain inorganic HAP's, prior to October 29, 1996 the flexibility to meet either the requirements of the promulgated regulation or the proposed amendments to the final regulation found in today's notice. Existing sources will be required to meet the requirements for depainting operations and topcoat or primer application operations found in the final amended rule.

H. Exemption for Waterborne Coatings

The EPA proposes that any waterborne coating for which the manufacturer's supplied data demonstrate that the coating meets the organic HAP and VOC content limits for its coating type as specified in the regulation be exempt from many of the organic HAP and VOC related requirements of this regulation. If the manufacturer's supplied data indicate that the waterborne coating meets the organic HAP and VOC content emission limits for its coating type, as specified in §§ 63.745(c) and 63.747(c), then the owner or operator would not be required to demonstrate compliance for these coatings using the procedures in § 63.750(c). However, the owner or operator would still be required to maintain purchase records and manufacturer's supplied data sheets for exempt coatings. Owners or operators of facilities using waterborne coatings would also be required to handle and

transfer these coatings in a manner that minimizes spills, apply these coatings using one or more of the specified application techniques, and comply with inorganic HAP emission requirements. This exemption would be added as § 63.741(i) as follows:

Any waterborne coating for which the manufacturer's supplied data demonstrate that organic HAP and VOC contents are less than or equal to the organic HAP and VOC content limits for its coating type, as specified in §§ 63.745(c) and 63.747(c), is exempt from the following requirements of this subpart: §§ 63.745(d)-(e), 63.747(d)-(e), 63.749(d) and (h), 63.750(c)-(h) and (k)-(m), 63.752(c) and (f), and 63.753(c) and (e). A facility shall maintain the manufacturer's supplied data and annual purchase records for each exempt waterborne coating readily available for inspection and review, and shall retain these data for 5 years.

Section 63.741(f) would also be modified to include § 63.741(i) in the list of additional specific exemptions from regulatory coverage.

The EPA is proposing this exemption for waterborne coatings based on settlement discussions with the two petitioners that filed for review of the compliance demonstration provisions for waterborne coatings in § 63.750. The Agency is proposing this exemption to streamline and simplify the requirements for owners and operators of facilities using these coatings and to encourage the use of waterborne coatings which may result in lower emissions than other coating types.

I. Essential Use Exemption for Cleaning Solvents

Under title VI of the Act and the Montreal Protocol, Essential Use Waivers have been granted for limited applications of ozone depleting compounds (ODC's). The EPA proposes that an essential use exemption be added to this rule for cleaning operations that have been identified in an Essential Use Waiver. The exemption would be added as § 63.744(e)(13) as follows:

Cleaning operations identified in an Essential Use Waiver which has been reviewed and approved by the U. S. EPA and the voting parties of the International Montreal Protocol Committee [sections 604(d)(1) and (g)(2) of the Act].

The EPA requests comments on this proposed essential use exemption.

J. Compliance Dates

The EPA wishes to clarify an inconsistency between the preamble to the final rule and the regulation. The preamble to the final aerospace NESHAP states, "Owners or operators of new commercial, civil, or military

aerospace OEM and rework operations with initial startup after September 1, 1998 will be required to comply with all requirements upon startup." This statement is incorrect. The text of the promulgated regulation correctly states that new sources, with initial startup on or after September 1, 1995, must comply with all requirements upon startup. The EPA also proposes to clarify that the deadline for approval of an alternate control device is 120 days prior to the compliance date. This clarification, mistakenly omitted from the published final rule, would be reflected in § 63.743(c).

K. Requirements for New Affected Sources (Spray Booths)

The Agency wishes to clarify the requirements for new affected sources. An affected source is an emission unit, process, or operation identified in the NESHAP that is part of the entire facility, but is not necessarily a major source. In today's proposal the Agency is clarifying its intent that a spray booth or hangar that contains a primer or topcoat application operation subject to § 63.745(g) or a depainting operation subject to § 63.746(b)(4) is considered an affected source and has added this description under § 63.741(c). If such an affected source is constructed or reconstructed after October 29, 1996 then that spray booth or hangar must comply with the applicable inorganic control requirements. Construction or reconstruction of a new spray booth or hangar at a facility for an existing coating or depainting operation will not cause the existing operation to be subject to any other new source standards; only the new spray booth or hangar will be subject to the applicable new source requirements for inorganic HAP and will need to comply upon the effective date of the requirements or startup, whichever is later. The EPA also proposes making this clarification in the final rule in § 63.749(a).

In addition, EPA wishes to clarify that §§ 63.5(b)(3) and (4) of the General Provisions, which require advance notice and approval by the Agency prior to construction or reconstruction of a major affected source, shall apply to the construction or reconstruction of a new spray booth or hangar at a facility for an existing coating or depainting operation only if the booth or hangar will constitute a major source of inorganic HAP's. Owners or operators of an existing coating or depainting operation who construct or reconstruct a new booth or hangar which is not a major source of inorganic HAP's will only be required to submit an annual notification on or before March 1 of

each year. This annual notification shall include all of the information required in § 63.4(b)(4) for each such booth or hangar constructed or reconstructed in the prior calendar year, except that the information shall be limited to the inorganic HAP's from the new booth or hangar. Of course, any owner or operator that constructs or reconstructs a new spray booth or hangar at a facility at which there is no existing coating or depainting operation will be required to comply with all of the applicable notice and advance approval requirements of § 63.5.

L. Requirements for New and Existing Primer and Topcoat Application Operations

Since promulgation, the Agency has received reports of confusion in interpreting the applicability of primer and topcoat application requirements to an industry that utilizes a plasma spray operation to apply metallic coatings to a metallic substrate. In today's preamble, the Agency notes that such a plasma spray operation is not subject to the aerospace manufacture and rework NESHAP, but would rather be addressed under the miscellaneous metal parts and products (surface coating) NESHAP that is scheduled for promulgation in 2000.

The Agency has also provided additional flexibility to owners or operators of primer and topcoat application operations seeking to use alternative application methods. The promulgated NESHAP requires owners or operators to use the alternative application method in production on actual production parts or assemblies for a period of time sufficient to coat an equivalent amount of parts and assemblies with coatings identical to those used in an initial 30-day period. After this time the actual organic HAP and VOC emissions shall be calculated for this post-implementation period. The proposed amendments to the final NESHAP allow owners or operators an alternative approach whereby the proposed application method is tested against either HVLP or electrostatic spray application methods in a laboratory or pilot production area, using parts and coatings representative of the process(es) where the alternative method is to be used. Under this alternative, the laboratory test will use the same part configuration(s) and the same number of parts for both the proposed method and the HVLP or electrostatic spray application methods. The Agency has added this alternative in response to comments received from industry indicating that the original requirements would require actual production trials that could result in

ineffective application equipment being used on actual production parts or assemblies.

M. Monitoring Requirements for Dry Particulate Filter Usage

The Agency proposes to clarify the monitoring requirements for owners or operators of depainting and painting operations using dry particulate filters and HEPA filters to comply with this NESHAP. The final rule requires owners or operators to install and maintain devices to continuously measure the pressure drop across the system. In this proposal, the Agency continues to require owners or operators to operate a device to continuously monitor this parameter at all times. This requirement does not require an owner or operator to continuously record the pressure drop. However, the Agency is adding language to § 63.751(c)(1) to clarify that owners or operators only are required to read and record these pressure drop data once per shift.

N. Depainting Operations

Based on numerous comments on the depainting operation standard, the EPA proposes a clarification to § 63.746. The promulgated standard was presented in terms of volume (gallons) of organic HAP-containing chemical strippers per aircraft. Since the NESHAP is specific to HAP, the EPA proposes changing the units of the standard and stating the requirements in terms of weight (pounds) of organic HAP materials per aircraft. The proposed standard is equivalent in terms of actual HAP emissions to the atmosphere, but does allow greater flexibility to the owner or operator of a new or existing depainting operation in selecting materials to perform spot stripping and decal removal.

The EPA proposes rewording § 63.746(b)(3) as follows:

Each owner or operator of a new or existing depainting operation complying with paragraph (b)(1) shall not, on an annual average basis, use more than 190 pounds of organic HAP material(s) per commercial aircraft depainted or more than 365 pounds of organic HAP material(s) per military aircraft depainted for spot stripping and decal removal.

Similarly, the EPA also proposes revising Equation 20 in § 63.750(j)(3) as follows:

$$C = \frac{\sum_{i=1}^n (V_{si} (\sum_{h=1}^m W_{hi} * D_{hi}))}{A} \quad \text{Eq. 20}$$

Where:

C =annual average weight (lb per aircraft) of organic HAP-material (chemical stripper) used for spot stripping and decal removal.

m =number of organic HAPs contained in each chemical stripper, as applied.

n =number of organic HAP-containing chemical strippers used in the annual period.

W_{hi} =weight fraction (expressed as a decimal) of each organic HAP (i) contained in the chemical stripper, as applied, for each aircraft depainted.

D_{hi} =density (lbs/gal) of each organic HAP (i) contained in the chemical stripper, as applied, for each aircraft depainted.

V_{si} =volume (gal) of organic HAP-containing chemical stripper i used for during the annual period.

A =number of aircraft for which depainting operations began during the annual period.

As further clarification, the promulgated standard for depainting operations and the above proposed rewording are meant to allow averaging in terms of annual usages of chemical strippers. For example, if a facility depaints 10 aircraft in a given calendar year, the total allowable amount of organic HAP material(s) would be 1,900 pounds per year for commercial aircraft or 3,650 pounds per year for military aircraft.

O. Applicability of General Provisions

The EPA proposes the addition of Table 1. General Provisions Applicability to subpart GG, in order to clarify the applicability of the General Provisions to this rule. Table 1 is referenced in § 63.741 and is located at the end of the final rule text.

III. Control Techniques Guideline

Under the Act, as amended in 1990, State implementation plans (SIP's) for ozone nonattainment areas must be revised to require RACT for control of VOC emissions from sources for which the EPA has already published a CTG or for which it will publish a CTG between the date the Amendments were enacted and the date an area achieves attainment status (the Act, 182(b)(2)). The EPA has defined RACT as "the lowest emission limitation that a particular source is capable of meeting by the application of control technology that is reasonably available considering the technological and economic feasibility" (44 FR 53761, September 17, 1979).

The CTG's review current knowledge and data concerning the technology and costs of various emissions control techniques. The CTG's are intended to

provide State and local air pollution authorities with an information base for proceeding with their own analyses of RACT to meet statutory requirements.

Each CTG contains a "presumptive norm" for RACT for a specific source category, based on the EPA's evaluation of the capabilities and problems general to the category. Where applicable, the EPA recommends that States adopt requirements consistent with the presumptive norm. However, the presumptive norm is only a recommendation. States may choose to develop their own RACT requirements on a case-by-case basis, considering the emission reductions needed to obtain achievement of the national ambient air quality standards and the economic and technical circumstances of the individual source.

This CTG addresses RACT for control of VOC emissions from aerospace manufacturing and rework facilities. Volatile organic compound emissions from primer, topcoat, and "specialty" coating application, maskant application, sealing, adhesives, and cleaning operations are addressed. Emission limits for processes also addressed in the NESHAP are identical to the NESHAP limits. Many of the steps in these operations involve the use of organic solvents and are sources of VOC emissions. The sources, mechanisms, and control of these VOC emissions are described in the CTG.

The EPA estimates that State and local regulations developed pursuant to this draft CTG would affect about 2,869 facilities. Since the only new requirements in the CTG (requirements that are not included in the NESHAP) concern sealants, adhesives, and specialty coatings, which represent only about 3 percent of all VOC emissions from aerospace operations, the additional costs and emission reductions resulting from the CTG will be negligible. Further information on costs is presented in the draft CTG document and in the NESHAP for Aerospace Manufacturing and Rework Facilities. The EPA requests comments from the public on all aspects of the draft CTG.

IV. Administrative Requirements

A. Docket

The docket is an organized and complete file of all of the information submitted to or otherwise considered by the EPA in the development of this rulemaking. The docket is a dynamic file, since material is added throughout the rulemaking development. The docketing system is intended to allow members of the public and the

industries involved to readily identify and locate documents so that they can effectively participate in the rulemaking process. Along with the statement of basis and purpose of the proposed and promulgated standards and the EPA responses to significant comments, the content of the docket will serve as the record in case of judicial review (except for interagency review materials) (§ 307(d)(7)(A) of the Act).

B. Paperwork Reduction Act

The information collection requirements contained in this proposed amendment to a final rule have been submitted to the Office of Management and Budget (OMB) for approval under the provisions of the Paperwork Reduction Act, 44 U.S.C. 3501 et seq. An Information Request Document has been prepared by the EPA and assigned ICR No. 1687.03. The collection of information required by the proposed amendments to the final rule has an estimated nationwide recordkeeping and reporting burden of 829,500 hours (\$29 million). This represents a 6 percent reduction in the burden estimated for the final rule.

Send comments regarding any aspect of this collection of information to Director, Regulatory Information Division, U. S. Environmental Protection Agency (2136), 401 M Street, SW, Washington, DC 20460; and to the Office of Information and Regulatory Affairs, Office of Management and Budget, Washington, DC 20503, marked "Attention: Desk Officer for EPA."

C. Executive Order 12866

Under Executive Order (E.O.) 12866 (58 FR 51735 [October 4, 1993]), the EPA is required to determine whether a regulation is "significant" and therefore subject to OMB review and the requirements of this E.O. to prepare a regulatory impact analysis (RIA). The E.O. defines "significant regulatory action" as one that is likely to result in a rule that may (1) have an annual effect on the economy of \$100 million or more, or adversely affect in a material way the economy, a sector of the economy, productivity, competition, jobs, the environment, public health or safety, or State, local, or Tribal governments or communities; (2) create a serious inconsistency or otherwise interfere with an action taken or planned by another agency; (3) materially alter the budgetary impact of entitlements, grants, user fees, or loan programs or the rights and obligations of recipients thereof; or (4) raise novel legal or policy issues arising out of legal mandates, the President's priorities, or the principles set forth in the E.O.

Pursuant to the terms of Executive Order 12866, it has been determined that this action is not a "significant regulatory action" within the meaning of the E.O.

Under E.O. 12866, the draft CTG document for aerospace manufacturing and rework facilities is considered "nonsignificant." This CTG document is not a "rulemaking," rather it provides information to States to aid them in developing rules.

D. Regulatory Flexibility Act

Pursuant to section 605(b) of the Regulatory Flexibility Act, 5 U.S.C. 605(b), I certify that this rule will not have a significant economic impact on a substantial number of small entities. This proposal would make clarifying amendments to the Aerospace NESHAP, including definitions, applicability, and several technical requirements. In addition, this notice proposes a standard for Type I chemical milling maskants and a test method for determining filtration efficiency of dry particulate filters. The overall impact of these amendments result in a net decrease in requirements on all entities affected by this rule, including small entities. Therefore these amendments will not have a significant impact on a substantial number of small entities.

Under the Regulatory Flexibility Act, an agency is not required to prepare a regulatory flexibility analysis for a rule that the agency head certifies will not have a significant economic impact on a substantial number of small entities. Consequently, a regulatory flexibility analysis is not required and has not been prepared.

E. Regulatory Review

In accordance with sections 112(d)(6) and 112(f)(2) of the Act, this regulation will be reviewed within 8 years of the date of promulgation. This review may include an assessment of such factors as evaluation of the residual health risk, any overlap with other programs, the existence of alternative methods of control, enforceability, improvements in emission control technology and health data, and recordkeeping and reporting requirements.

F. Unfunded Mandates Act

The economic impact analysis performed prior to the original proposal showed that the economic impacts from implementation of the proposed standards would not be "significant" as defined in Executive Order 12866 (see section III.E). No changes have been made that would increase the economic impacts to a level that would be considered significant. The Agency has prepared the following statement of impact to be considered in response to

the requirements of the Unfunded Mandates Act.

There are no Federal funds available to assist State, local, and tribal governments in meeting these costs. There are important benefits from VOC and HAP emission reductions because these compounds have significant, adverse impacts on human health and welfare and on the environment. The rule does not have any disproportionate budgetary effects on any particular region of the nation, any State, local, or tribal government, or urban, rural, or other type of community. On the contrary, the rule will result in only a minimal increase in the average product rates (less than 1 percent). Moreover, the rule will not have a material effect on the national economy.

Prior to issuing the final rule on September 1, 1995, the EPA provided numerous opportunities (e.g., public comment period; public hearing; roundtable meetings with industry, trade association, and State and local air pollution control agency representatives; environmental groups; State, local, and tribal governments; and concerned citizens) for consultation with interested parties. While small governments are not significantly or uniquely affected by the rule, these procedures, as well as additional public conferences and meetings, gave small governments an opportunity to give meaningful and timely input and obtain information, education, and advice on compliance.

The Agency considered several regulatory options in developing the rule. The options selected are the least costly and least burdensome alternatives currently available for achieving the objectives of section 112 of the Act. All but one of the regulatory options selected are based on pollution prevention measures. Finally, after careful consideration of the costs, the environmental impacts, and the comments, the Agency decided that the MACT floor was the appropriate level of control for this regulation.

List of Subjects in 40 CFR Part 63

Environmental protection, Air pollution control, Hazardous substances.

Dated: October 8, 1996.

Carol M. Browner,
Administrator.

For reasons set out in the preamble, part 63 of title 40, chapter I, of the Code of Federal Regulations is proposed to be amended as follows:

PART 63—[AMENDED]

1. The authority citation for part 63 continues to read as follows:

Authority: 42 U.S.C. 7401, *et seq.*

Subpart GG—[Amended]

2. Section 63.741 is amended by revising paragraphs (b), (c) introductory text, and the last three sentences in paragraph (f); and by adding paragraphs (c)(7), (h), (i), and (j) to read as follows:

§ 63.741 Applicability and designation of affected sources.

* * * * *

(b) The owner or operator of an affected source shall comply with the requirements of this subpart and of subpart A of this part, except as specified in § 63.743(a) and Table 1 of this subpart.

(c) *Affected sources.* The affected sources to which the provisions of this subpart apply are specified in paragraphs (c) (1) through (7) of this section. The activities subject to this subpart are limited to the manufacture or rework of aerospace vehicles or components as defined in this subpart. Where a dispute arises relating to the applicability of this subpart to a specific activity, the owner or operator shall demonstrate whether or not the activity is regulated under this subpart.

* * * * *

(7) Each spray booth or hangar that contains a primer or topcoat application operation subject to § 63.745(g) or a repainting operation subject to § 63.746(b)(4).

* * * * *

(f) * * * These requirements also do not apply to parts and assemblies not critical to the vehicle's structural integrity or flight performance. The requirements of this subpart also do not apply to primers, topcoats, chemical milling maskants, strippers, and cleaning solvents containing HAP and VOC at a concentration less than 0.1 percent for carcinogens or 1.0 percent for noncarcinogens, as determined from manufacturer's representations. Additional specific exemptions from regulatory coverage are set forth in paragraphs (e), (g), (h), (i), and (j) of this section, and §§ 63.744(a)(1), (b), (e), 63.745(a), (f)(3), (g)(4), 63.746(a), (b)(5), 63.747(c)(3), and 63.749(d).

* * * * *49(d).

* * * * *

(h) Regulated activities associated with space vehicles designed to travel beyond the limit of the earth's atmosphere, including but not limited to satellites, space stations, and the Space Shuttle System (including orbiter, external tanks, and solid rocket

boosters), are exempt from the requirements of this subpart, except for repainting operations found in § 63.746.

(i) Any waterborne coating for which supplied data demonstrate that organic HAP and VOC contents are less than or equal to the organic HAP and VOC content limits for its coating type, as specified in §§ 63.745(c) and 63.747(c), is exempt from the following requirements of this subpart: §§ 63.745 (d) through (e), 63.747 (d) through (e), 63.749 (d) and (h), 63.750 (c) through (h) and (k) through (m), 63.752 (c) and (f), and 63.753 (c) and (e). A facility shall maintain the manufacturer's supplied data and annual purchase records for each exempt waterborne coating readily available for inspection and review and shall retain these data for 5 years.

(j) This subpart does not apply to rework operations performed on antique aerospace vehicles or components.

3. Section 63.742 is amended by revising the definitions for "aircraft transparency," "chemical milling maskant," "chemical milling maskant application operation," "cleaning solvent," "high volume low pressure (HVLV) spray equipment," and "specialty coating"; and by adding in alphabetical order definitions for "antique aerospace vehicle or component," "closed-cycle repainting system," and "waterborne (water-reducible) coating" to read as follows:

§ 63.742 Definitions.

* * * * *

Aircraft transparency means the aircraft windshield, canopy, passenger windows, lenses, and other components that are constructed of transparent materials.

Antique aerospace vehicle or component means an antique aircraft, as defined by 14 CFR part 45, or components thereof. An antique aerospace vehicle would not routinely be in commercial or military service in the capacity for which it was designed.

* * * * *

Chemical milling maskant means a coating that is applied directly to aluminum components to protect surface areas when chemical milling the component with a Type I or Type II etchant. This does not include bonding maskants, line sealers, and critical use and seal coat maskants. Additionally, maskants that must be used on an individual part or subassembly with a combination of Type I or II etchants and any of the above types of maskants (e.g., bonding, line sealers, and critical use and seal coat) are also exempt from this subpart.

Chemical milling maskant application operation means application of

chemical milling maskant for use in Type I or Type II chemical milling etchants.

* * * * *

Cleaning solvent means a liquid material used for hand-wipe, spray gun, or flush cleaning. This definition does not include solutions that contain HAP and VOC below the de minimis levels specified in § 63.741(f) (e.g., water or acetone).

Closed-cycle repainting system means a dust-free, automated process that removes permanent coating in small sections at a time and maintains a continuous vacuum around the area(s) being repainted to capture emissions.

* * * * *

High volume low pressure (HVLV) spray equipment means spray equipment that is used to apply coating by means of a spray gun that operates at 10.0 psig of atomizing air pressure or less at the air cap.

* * * * *

Specialty coating means a coating that, even though it meets the definition of a primer, topcoat, or self-priming topcoat, has additional performance criteria beyond those of primers, topcoats, and self-priming topcoats for specific applications. These performance criteria may include, but are not limited to, temperature or fire resistance, substrate compatibility, antireflection, temporary protection or marking, sealing, adhesively joining substrates, or enhanced corrosion protection. Individual specialty coatings are defined in appendix A to this subpart and in the CTG for Aerospace Manufacturing and Rework Operations.

* * * * *

Waterborne (water-reducible) coating means any coating that contains more than 5 percent water by weight as applied in its volatile fraction.

* * * * *

4. Section 63.743 is amended by revising paragraphs (a) introductory text, (b) introductory text, and (c); and by adding paragraphs (a)(10) and (d) to read as follows:

§ 63.743 Standards: General.

(a) Except as provided in paragraphs (a)(4) through (a)(9) of this section and in Table 1 of this subpart, each owner or operator of an affected source subject to this subpart is also subject to the following sections of subpart A of this part:

* * * * *

(10) For the purposes of compliance with the requirements of § 63.5(b)(4) of the General Provisions and this subpart, owners or operators of existing primer or topcoat application operations and

repainting operations who construct or reconstruct a spray booth or hangar that is not a major source of inorganics shall only be required to notify the Administrator of such construction or reconstruction on an annual basis. Notification shall be submitted on or before March 1 of each year and shall include the information required in § 63.5(b)(4) for each such spray booth or hangar constructed or reconstructed during the prior calendar year, except that such information shall be limited to inorganic HAP's. No advance notification or written approval from the Administrator pursuant to § 63.5(b)(3) shall be required for the construction or reconstruction of such a spray booth or hangar unless the booth or hangar will constitute a major-emitting source or inorganic HAP's.

(b) *Startup, shutdown, and malfunction plan.* Each owner or operator that uses an air pollution control device or equipment to control HAP emissions shall prepare and operate in accordance with a startup, shutdown, and malfunction plan in accordance with § 63.6. Dry particulate filter systems operated per the manufacturer's instructions are exempt from a startup, shutdown, and malfunction plan. A startup, shutdown, and malfunction plan shall be prepared for facilities using locally prepared operating procedures. In addition to the information required in § 63.6, this plan shall also include the following provisions:

* * * * *

(c) An owner or operator who uses an air pollution control device or equipment not listed in this subpart shall submit a description of the device or equipment, test data verifying the performance of the device or equipment in controlling organic HAP and/or VOC emissions, as appropriate, and specific operating parameters that will be monitored to establish compliance with the standards to the Administrator for approval not later than 120 days prior to the compliance date.

(d)(1) Use any combination of primers, topcoats, or chemical milling maskants such that the monthly volume-weighted average organic HAP and VOC contents of the combination of primers, topcoats, or chemical milling maskants, as determined in accordance with the applicable procedures set forth in § 63.750, complies with the specified content limits, unless the permitting agency specifies a shorter averaging period as part of an ambient ozone control program.

(2) Averaging is allowed only for uncontrolled primers, topcoats, or chemical milling maskants.

(3) Each averaging scheme shall be approved in advance by the permitting agency and adopted as part of the facility's title V permit.

5. Section 63.744 is amended by revising paragraphs (a) introductory text, (b) introductory text, (a)(1), (a)(2), (c)(1)(ii), (c)(2), (c)(4), (e)(1), (e)(2), (e)(9), (e)(10); by adding paragraph (e)(13); and by redesignating Table 3 as Table 1 and revising it and transferring it from paragraph (a) to the end of section, as follows:

§ 63.744 Standards: Cleaning operations.

(a) *Housekeeping measures.* Each owner or operator of a new or existing cleaning operation subject to this subpart shall comply with the requirements in this paragraph unless the cleaning solvent used is identified in Table 1 of this section or contains HAP and VOC below the de minimis levels specified in § 63.741(f).

(1) Place cleaning solvent-laden cloth, paper, or any other absorbent applicators used for cleaning in bags or other closed containers upon completing their use. Ensure that these bags and containers are kept closed at all times except when depositing or removing these materials from the container. Use bags and containers of such design so as to contain the vapors of the cleaning solvent. Cotton-tipped swabs used for very small cleaning operations are exempt from this requirement.

(2) Store fresh and spent cleaning solvents, except semi-aqueous solvent cleaners, used in aerospace cleaning operations in closed containers.

(b) *Hand-wipe cleaning.* Each owner or operator of a new or existing hand-wipe cleaning operation (excluding cleaning of spray gun equipment performed in accordance with paragraph (c)(3) of this section) subject to this subpart shall use cleaning solvents that meet one of the requirements specified in paragraphs (b)(1), (b)(2), and (b)(3) of this section. Cleaning solvent solutions that contain HAP or VOC below the de minimis levels specified in § 63.741(f) are exempt from the requirements in paragraphs (b)(1), (b)(2), and (b)(3).

(c) * * *
(1) * * *
(ii) If leaks are found during the monthly inspection required in § 63.751(a), repairs shall be made as soon as practicable, but no later than 15 days after the leak was found. If the leak is not repaired by the 15th day after detection, the cleaning solvent shall be removed, and the enclosed cleaner shall be shut down until the leak is repaired or its use is permanently discontinued.

(2) *Nonatomized cleaning.* Clean the spray gun by placing cleaning solvent in the pressure pot and forcing it through the gun with the atomizing cap in place. No atomizing air is to be used. Direct the cleaning solvent from the spray gun into a vat, drum, or other waste container that is closed when not in use.

(4) *Atomizing cleaning.* Clean the spray gun by forcing the cleaning solvent through the gun and direct the resulting atomized spray into a waste container that is fitted with a device designed to capture the atomized cleaning solvent emissions.

(e) * * *
(1) Cleaning during the manufacture, assembly, installation, maintenance, or testing of components of breathing oxygen systems that are exposed to the breathing oxygen;
(2) Cleaning during the manufacture, assembly, installation, maintenance, or testing of parts, subassemblies, or assemblies that are exposed to strong oxidizers or reducers (e.g., nitrogen tetroxide, liquid oxygen, or hydrazine);

(9) Cleaning of metallic and non-metallic materials used in honeycomb cores during the manufacture or maintenance of these cores, and cleaning of the completed cores used in the manufacture of aerospace vehicles or components;

(10) Cleaning of aircraft transparencies, polycarbonate, or glass substrates;

(13) Cleaning operations identified in an Essential Use Waiver, which has been reviewed and approved by the U. S. EPA and the voting parties of the International Montreal Protocol Committee [sections 604(d)(1) and (g)(2) of the Act].

TABLE 1.—COMPOSITION REQUIREMENTS FOR APPROVED CLEANING SOLVENTS

Cleaning solvent type	Composition requirements
Aqueous	Cleaning solvents in which water is the primary ingredient (≥80 percent of cleaning solvent solution as applied must be water). Detergents, surfactants, and bioenzyme mixtures and nutrients may be combined with the water along with a variety of additives, such as organic solvents (e.g., high boiling point alcohols), builders, saponifiers, inhibitors, emulsifiers, pH buffers, and antifoaming agents. Aqueous solutions must have a flash point greater than 93°C (200°F) (as reported by the manufacturer), and the solution must be miscible with water.
Hydrocarbon-based	Cleaners that are composed of photochemically reactive hydrocarbons and oxygenated hydrocarbons and have a maximum vapor pressure of 7 mm Hg at 20°C (3.75 in H ₂ O at 68°F). These cleaners also contain no HAP or ozone depleting compounds.

6. Section 63.745 is amended by revising paragraph (e) introductory text, (g)(2)(i), (g)(2)(ii), (g)(2)(iii); removing paragraph (g)(2)(iv) and redesignating paragraphs (g)(2)(v) and (g)(2)(vi) as (g)(2)(iv) and (g)(2)(v), respectively, to read as follows:

§ 63.745 Standards: Primer and topcoat application operations.

* * * * *

(e) *Compliance methods.* Compliance with the organic HAP and VOC content limits specified in paragraphs (c)(1) through (c)(4) of this section shall be accomplished by using the methods specified in paragraphs (c)(1) through (c)(4) of this section and § 63.743(d) of this subpart either by themselves or in conjunction with one another.

* * * * *

(g) * * *
(2) * * *

(i) For existing sources, the owner or operator must choose one of the following:

(A) Before exhausting it to the atmosphere, pass the air stream through a dry particulate filter system certified by the filter manufacturer using the methods described in § 63.750(o) to meet or exceed the efficiency data points in Tables 1 and 2; or

TABLE 1.—TWO-STAGE ARRESTOR;
LIQUID PHASE CHALLENGE

Filtration efficiency requirement, %	Aerodynamic particle size range, μm
>90	>5.7
>50	>4.1
>10	>2.2

TABLE 2.—TWO-STAGE ARRESTOR;
SOLID PHASE CHALLENGE

Filtration efficiency requirement, %	Aerodynamic particle size rang, μm
>90	>8.1
>50	>5.0
>10	>2.6

(B) Before exhausting it to the atmosphere, pass the air stream through a waterwash system that shall remain in operation during all coating application operations; or

(C) Before exhausting it to the atmosphere, pass the air stream through an air pollution control system that meets or exceeds the efficiency data points in Tables 1 and 2 and is approved by the permitting authority.

(ii) For new sources, either:

(A) Before exhausting it to the atmosphere, pass the air stream through a dry particulate filter system certified by the filter manufacturer using the methods described in § 63.750(o) to meet or exceed the efficiency data points in Tables 3 and 4; or

TABLE 3.—THREE-STAGE ARRESTOR;
LIQUID PHASE CHALLENGE

Filtration efficiency requirement, %	Aerodynamic particle size range, μm
>95	>2.0
>80	>1.0
>65	>0.42

TABLE 4.—THREE-STAGE ARRESTOR;
SOLID PHASE CHALLENGE

Filtration efficiency requirement, %	Aerodynamic particle size range, μm
>95	>2.5
>85	>1.1
>75	>0.70

(B) Before exhausting it to the atmosphere, pass the air stream through an air pollution control system that meets or exceeds the efficiency data points in Tables 3 and 4 and is approved by the permitting authority.

(iii) Owners or operators of new sources that have commenced construction or reconstruction after September 1, 1995, but prior to October

29, 1996, may comply with the following requirements in lieu of the requirements in paragraph (g)(2)(ii) of this section:

(A) Pass the air stream through either a two-stage dry particulate filter system or a waterwash system before exhausting it to the atmosphere.

(B) If the primer or topcoat contains chromium or cadmium, control shall consist of a HEPA filter system, three-stage filter system, or other control system equivalent to the three stage filter system as approved by the permitting agency.

7. Section 63.746 is amended by revising paragraphs (b)(1), (b)(3), (b)(4)(i), (b)(4)(ii), and the second sentence of paragraph (b)(4)(v) to read as follows:

§ 63.746 Standards: Depainting operations.

(b)(1) *HAP emissions—non-HAP chemical strippers and technologies.* Except as provided in paragraph (b)(2) or (b)(3) of this section, each owner or operator of a new or existing aerospace depainting operation subject to this subpart shall emit no organic HAP from chemical stripping formulations and agents or chemical paint softeners.

(3) Each owner or operator of a new or existing depainting operation complying with paragraph (b)(1) of this section shall not, on an annual average basis, use more than 190 pounds of organic HAP material(s) per commercial aircraft depainted or more than 365 pounds of organic HAP material(s) per military aircraft depainted for spot stripping and decal removal.

(i) Perform the depainting operation in an enclosed area, unless a closed-cycle depainting system is used.

(ii) (A) For existing sources, pass any air stream removed from the enclosed area or closed-cycle depainting system through a dry particulate filter system, certified by the filter manufacturer using the method described in § 63.750(o) to meet or exceed the efficiency data points in Tables 1 and 2 of § 63.745, through a baghouse, or through a waterwash system before exhausting it to the atmosphere.

(B) For new sources pass any air stream removed from the enclosed area or closed-cycle depainting system through a dry particulate filter system certified by the filter manufacturer using the method described in § 63.750(o) to meet or exceed the efficiency data points in Tables 3 and 4 of § 63.745 or

through a baghouse before exhausting it to the atmosphere.

(v) * * * If the water path in the waterwash system fails the visual continuity/flow characteristics check or the water flow rate, as recorded pursuant to § 63.752(e)(7), or the water flow rate, as recorded pursuant to § 63.752(d)(2), exceeds the limit(s) specified by the booth manufacturer or in locally prepared operating procedures, or the booth manufacturer's or locally prepared maintenance procedures for the filter or waterwash system have not been performed as scheduled, shut down the operation immediately and take corrective action.

8. Section 63.747 is amended by revising paragraphs (c)(1), (c)(2) and (e) introductory text to read as follows:

§ 63.747 Standards: Chemical milling maskant application operations.

(1) Organic HAP emissions from chemical milling maskants shall be limited to organic HAP content levels of 622 grams of organic HAP per liter (5.2 lb/gal) of Type I chemical milling maskant (less water) as applied, and no more than 160 grams of organic HAP per liter (1.3 lb/gal) of Type II chemical milling maskant (less water) as applied.

(2) VOC emissions from chemical milling maskants shall be limited to VOC content levels of no more than 622 grams of VOC per liter (5.2 lb/gal) of Type I chemical milling maskant (less water and exempt solvents) as applied, and no more than 160 grams of VOC per liter (1.3 lb/gal) of Type II chemical milling maskant (less water and exempt solvents) as applied.

(e) *Compliance methods.* Compliance with the organic HAP and VOC content limits specified in paragraphs (c)(1) and (c)(2) of this section shall be accomplished by using the methods specified in paragraphs (c)(1) and (c)(2) of this section and § 63.743(d) of this subpart either by themselves or in conjunction with one another.

9. Section 63.749 is amended by revising paragraphs (a), (b), (f)(3)(ii)(A), and (h)(3)(i) to read as follows:

§ 63.749 Compliance dates and determinations.

(a) *Compliance dates.* Each owner or operator of an existing affected source subject to this subpart shall comply with the requirements of this subpart by

September 1, 1998, except as specified in this section. Owners or operators of new affected sources subject to this subpart shall comply on the effective date or upon startup, whichever is later. In addition, each owner or operator shall comply with the compliance dates specified in § 63.6(b) and § 63.6(c). Owners or operators of existing primer or topcoat application operations and repainting operations who construct or reconstruct a spray booth or hanger must comply with the new source requirements for inorganic HAP specified in §§ 63.745(g)(2)(ii) and 63.746(b)(4) for that new spray booth or hanger upon startup.

(b) *General.* Each facility subject to this subpart shall be considered in noncompliance if the owner or operator fails to submit a startup, shutdown, and malfunction plan as required by § 63.743(b) or uses a control device other than one specified in this subpart that has not been approved by the Administrator, as required by § 63.743(c).

* * * * *

(f) * * *
(3) * * *
(ii) * * *

(A) For any spot stripping and decal removal, the value of C, as determined using the procedures specified in § 63.750(j), is less than or equal to 190 pounds of organic HAP material(s) per commercial aircraft depainted or more than 365 pounds of organic HAP material(s) per aircraft depainted for military aircraft calculated on a yearly average; and

* * * * *

(h) * * *
(3) * * *

(i) For all uncontrolled chemical milling maskants, all values of H_i and H_a (as determined using the procedures specified in § 63.750(k) and (l)) are less than or equal to 622 grams of organic HAP per liter (5.2 lb/gal) of Type I chemical milling maskant as applied (less water), and 160 grams of organic HAP per liter (1.3 lb/gal) of Type II chemical milling maskant as applied (less water). All values of G_i and G_a (as determined using the procedures specified in § 63.750(m) and (n)) are less than or equal to 622 grams of organic VOC per liter (5.2 lb/gal) of Type I chemical milling maskant as applied (less water and exempt solvents), and 160 grams of VOC per liter (1.3 lb/gal) of Type II chemical milling maskant (less water and exempt solvents) as applied.

* * * * *

10. Section 63.750 is amended by revising paragraphs (c)(1), (e)(1),

Equation 7 ("Eq. 7") in (e)(2), (g)(3)(ii), (i)(1), (i)(2)(ii), (i)(2)(iii), (equation 19 remains unchanged), (j) introductory text, (j)(1), (j)(3) and (k)(1); and by adding paragraph (o) to read as follows:

§ 63.750 Test methods and procedures.

* * * * *

(c) * * *

(1) For coatings that contain no exempt solvents, determine the total organic HAP content using manufacturer's supplied data or Method 24 of 40 CFR part 60, appendix A, to determine the VOC content. The VOC content shall be used as a surrogate for total HAP content for coatings that contain no exempt solvent. If there is a discrepancy between the manufacturer's formulation data and the results of the Method 24 analysis, compliance shall be based on the results from the Method 24 analysis.

* * * * *

(e) * * *

(1) Determine the VOC content of each formulation (less water and exempt solvents) as applied using manufacturer's supplied data or Method 24 of 40 CFR part 60, appendix A, to determine the VOC content. The VOC content shall be used as a surrogate for total HAP content for coatings that contain no exempt solvent. If there is a discrepancy between the manufacturer's formulation data and the results of the Method 24 analysis, compliance shall be based on the results from the Method 24 analysis.

(2) * * *

$$G_i = \frac{M_{vi}}{(1 - V_{wi}) - V_{xi}} \quad \text{Eq. 7}$$

* * * * *

(g) * * *

(3) * * *

(ii) Assure that all HAP emissions from the affected HAP emission point(s) are segregated from gaseous emission points not affected by this subpart and that the emissions can be captured for measurement, as described in 63.750(g)(2)(ii)(A) and (B);

* * * * *

(i)(1) *Alternative application method—primers and topcoats.* Each owner or operator seeking to use an alternative application method (as allowed in § 63.745(f)(1)(ix)) in complying with the standards for primers and topcoats shall use either the procedures specified in paragraphs (i)(2)(i) or (i)(2)(ii) of this section to determine the organic HAP and VOC emission levels of the alternative application technique as compared to either HVLP or electrostatic spray application methods.

(2) * * *

(ii) Test the proposed application method against either HVLP or electrostatic spray application methods in a laboratory or pilot production area, using parts and coatings representative of the process(es) where the alternative method is to be used. The laboratory test will use the same part configuration(s) and the same number of parts for both the proposed method and the HVLP or electrostatic spray application methods.

(iii) Whenever the approach in either paragraph (i)(2)(i) or (i)(2)(ii) is used, the owner or operator shall calculate both the organic HAP and VOC emission reduction using equation 19:

* * * * *

(j) *Spot stripping and decal removal.*

Each owner or operator seeking to comply with § 63.746(b)(3) shall determine the weight of organic HAP material used per aircraft using the procedure specified in paragraphs (j)(1) through (j)(3) of this section.

(1) For each chemical stripper used for spot stripping and decal removal, determine for each annual period the total weight of organic HAP material using the procedure specified in paragraph (d)(2) of this section.

* * * * *

(3) Calculate the annual average weight of organic HAP material used for spot stripping and decal removal per aircraft using equation 20:

$$C = \frac{\sum_{i=1}^n (V_{si} (\sum_{i=1}^m W_{hi} * D_{hi}))}{A} \quad \text{Eq. 20}$$

Where:

- C=annual average weight (lb per aircraft) of organic HAP-material (chemical stripper) used for spot stripping and decal removal.
- m=number of organic HAPs contained in each chemical stripper, as applied.
- n=number of organic HAP-containing chemical strippers used in the annual period.
- W_{hi}=weight fraction (expressed as a decimal) of each organic HAP (i) contained in the chemical stripper, as applied, for each aircraft depainted.
- D_{hi}=density (lbs/gal) of each organic HAP (i) contained in the chemical stripper, as applied, for each aircraft depainted.
- V_{si}=volume (gal) of organic HAP-containing chemical stripper i used for during the annual period.
- A=number of aircraft for which depainting operations began during the annual period.

(k) * * *

(1) For coatings that contain no exempt solvents, determine the total organic HAP content using manufacturer's supplied data or Method 24 of 40 CFR part 60, appendix A to determine the VOC content. The VOC content shall be used as a surrogate for total HAP content for coatings that contain no exempt solvent. If there is a discrepancy between the manufacturer's formulation data and the results of the Method 24 analysis, compliance shall be based on the results from the Method 24 analysis.

(o) *Inorganic HAP emissions—dry particulate filter certification requirements.* Dry particulate filters used to comply with § 63.745(g)(2) or § 63.746(b)(4) must be certified by the filter manufacturer, using method 319 in appendix A of subpart A of this part, to meet or exceed the efficiency data points found in Tables 4 and 5, or 6 and 7 of this section for existing or new sources respectively.

11. Section 63.751 is amended by revising the first sentence of paragraph (b)(6)(ii)(A), paragraph (b)(6)(iii) introductory text, and the first sentence of paragraph (b)(6)(iii)(A)(2), introductory text and paragraphs (b)(6)(iii)(D), (c)(1), (c)(2) and (d) to read as follows:

§ 63.751 Monitoring requirements.

- * * * * *
- (b) * * *
- (6) * * *
- (ii) * * *

(A) Except as allowed by paragraph (b)(6)(iii)(A)(2) of this section, all continuous emission monitors shall comply with performance specification (PS) 8 or 9 in 40 CFR part 60, appendix B, as appropriate depending on whether VOC or HAP concentration is being measured. * * *

* * * * *

(iii) Owners or operators complying with § 63.745(d), § 63.746(c), or § 63.747(d) through the use of a control device and establishing a site-specific operating parameter in accordance with paragraph (b)(1) shall fulfill the requirements of paragraph (b)(6)(iii)(A) of this section and paragraph (b)(6)(iii)(B) or (C) of this section, as appropriate.

* * * * *

(A) * * *

(2) For owners or operators using a nonregenerative carbon adsorber, in lieu

of using continuous emission monitors as specified in paragraph (b)(6)(iii)(A)(1) of this section, the owner or operator may use a portable monitoring device to monitor total HAP or VOC concentration at the inlet and outlet or the outlet of the carbon adsorber as appropriate. * * *

* * * * *

(D) If complying with § 63.745(d), § 63.746(c), or § 63.747(d) through the use of a nonregenerative carbon adsorber, in lieu of the requirements of paragraph (b)(6)(iii)(B) or (C) of this section, the owner or operator may replace the carbon in the carbon adsorber system with fresh carbon at a regular predetermined time interval as determined in accordance with paragraph (b)(2) of this section.

* * * * *

(c) * * *

(1) Each owner or operator using a dry particulate filter system to meet the requirements of § 63.745(g)(2) shall, while primer or topcoat application operations are occurring, continuously monitor the pressure drop across the system and read and record the pressure drop once per shift following the recordkeeping requirements of § 63.752(d).

(2) Each owner or operator using a waterwash system to meet the requirements of § 63.745(g)(2) shall, while primer or topcoat application operations are occurring, continuously monitor the water flow rate through the system and read an record the water flow rate once per shift following the recordkeeping requirements of § 63.752(d).

(d) *Particulate filters and waterwash booths—depainting operations.* Each owner or operator using a dry particulate filter or waterwash system in accordance with the requirements of § 63.746(b)(4) shall, while depainting operations are occurring, continuously monitor the pressure drop across the particulate filters or the water flow rate through the waterwash system and read and record the pressure drop or the water flow rate once per shift following the recordkeeping requirements of § 63.752(e).

* * * * *

12. Section 63.752 is amended by revising paragraphs (b)(1), (e)(6) and (f) introductory text; and by removing paragraph (d)(4) to read as follows:

§ 63.752 Recordkeeping requirements.

* * * * *

(b) * * *

(1) The name, vapor pressure, and documentation showing the organic HAP constituents of each cleaning solvent used for affected cleaning operations at the facility.

* * * * *

(e) * * *

(6) *Spot stripping and decal removal.* For spot stripping and decal removal, the weight of organic HAP-material used, the annual average weight of organic HAP-material used per aircraft, the annual number of aircraft stripped, and all data and calculations used.

* * * * *

(f) *Chemical milling maskant application operations.* Each owner or operator seeking to comply with the organic HAP and VOC content limits for the chemical milling maskant application operation, as specified in § 63.747(c) and (d), shall record the information specified in paragraphs (f)(1) through (f)(4) of this section, as appropriate.

* * * * *

13. Section 63.753 is amended by revising paragraph (a)(1) introductory text to read as follows:

§ 63.753 Reporting requirements.

(a)(1) Except as provided in paragraphs (a)(2) and (a)(3) of this section, each owner or operator subject to this subpart shall fulfill the requirements contained in § 63.9(a) through (e) and (h) through (j). Notification requirements, and § 63.10 (a), (b), (d), and (f), Recordkeeping and reporting requirements, of the General Provisions, 40 CFR part 63, subpart A, except that the initial notification requirements for new or reconstructed affected sources in § 63.9(b) (3) through (5) shall not apply, and that the initial notification for existing sources that the source is subject to the standard required in § 63.9(b)(2) shall be submitted not later than September 1, 1997. In addition to the requirements of 63.9(h), the notification of compliance status shall include:

* * * * *

14. Table 1 is added to the end of subpart GG to read as follows:

TABLE 1 TO SUBPART GG.—GENERAL PROVISIONS APPLICABILITY TO SUBPART GG

Reference	Applies to affected sources in subpart GG	Comment
63.1(a)(1)	Yes	

TABLE 1 TO SUBPART GG.—GENERAL PROVISIONS APPLICABILITY TO SUBPART GG—Continued

Reference	Applies to affected sources in subpart GG	Comment
63.1(a)(2)	Yes	
63.1(a)(3)	Yes	
63.1(a)(4)	Yes	
63.1(a)(5)	No	Reserved.
63.1(a)(6)	Yes	
63.1(a)(7)	Yes	
63.1(a)(8)	Yes	
63.1(a)(9)	No	Reserved.
63.1(a)(10)	Yes	
63.1(a)(11)	Yes	
63.1(a)(12)	Yes	
63.1(a)(13)	Yes	
63.1(a)(14)	Yes	
63.1(b)(1)	Yes	
63.1(b)(2)	Yes	
63.1(b)(3)	Yes	
63.1(c)(1)	Yes	
63.1(c)(2)	Yes	Subpart GG does not apply to area sources.
63.1(c)(3)	No	Reserved.
63.1(c)(4)	Yes	
63.1(c)(5)	Yes	
63.1(d)	No	Reserved.
63.1(e)	Yes	
63.2	Yes	
63.3	Yes	
63.4(a)(1)	Yes	
63.4(a)(2)	Yes	
63.4(a)(3)	Yes	
63.4(a)(4)	No	Reserved.
63.4(a)(5)	Yes	
63.4(b)	Yes	
63.4(c)	Yes	
63.5(a)	Yes	
63.5(b)(1)	Yes	
63.5(b)(2)	No	Reserved.
63.5(b)(3)	Yes	
63.5(b)(4)	Yes	
63.5(b)(5)	Yes	
63.5(b)(6)	Yes	
63.5(c)	No	Reserved.
63.5(d)(1)(i)	Yes	
63.5(d)(1)(ii)(A)–(H)	Yes	
63.5(d)(1)(ii)(I)	No	Reserved.
63.5(d)(1)(ii)(J)	Yes	
63.5(d)(1)(iii)	Yes	
63.5(d)(2)–(4)	Yes	
63.5(e)	Yes	
63.5(f)	Yes	
63.6(a)	Yes	
63.6(b)(1)–(5)	No	§ 63.749(a) specifies compliance dates for new sources.
63.6(b)(6)	No	Reserved.
63.6(b)(7)	Yes	
63.6(c)(1)	Yes	
63.6(c)(2)	No	The standards in subpart GG are promulgated under section 112(d) of the Act.
63.6(c)(3)–(4)	No	Reserved.
63.6(c)(5)	Yes	
63.6(d)	No	Reserved.
63.6(e)	Yes	§ 63.743(b) includes additional provisions for the operation and maintenance plan.
63.6(f)	Yes	
63.6(g)	Yes	
63.6(h)	No	The standards in subpart GG do not include opacity standards.
63.6(i)(1)–(3)	Yes	
63.6(i)(4)(i)(A)	Yes	
63.6(i)(4)(i)(B)	No	§ 63.743(a)(4) specifies that requests for extension of compliance must be submitted no later than 120 days before an affected source's compliance date.
63.6(i)(4)(ii)	No	The standards in subpart GG are promulgated under section 112(d) of the Act.

TABLE 1 TO SUBPART GG.—GENERAL PROVISIONS APPLICABILITY TO SUBPART GG—Continued

Reference	Applies to affected sources in subpart GG	Comment
63.6(i) (5)–(12)	Yes	
63.6(i)(13)	Yes	
63.6(i)(14)	Yes	
63.6(i)(15)	No	Reserved.
63.6(i)(16)	Yes	
63.6(j)	Yes	
63.7(a)(1)	Yes	
63.7(a)(2) (i)–(vi)	Yes	
63.7(a)(2) (vii)–(viii)	No	Reserved.
63.7(a)(2)(ix)	Yes	
63.7(a)(3)	Yes	
63.7(b)	Yes	
63.7(c)	Yes	
63.7(d)	Yes	
63.7(e)	Yes	
63.7(f)	Yes	
63.7(g)(1)	Yes	
63.7(g)(2)	No	Reserved.
63.7(g)(3)	Yes	
63.7(h)	Yes	
63.8(a) (1)–(2)	Yes	
63.8(a)(3)	No	Reserved.
63.8(a)(4)	Yes	
63.8(b)	Yes	
63.8(c)	Yes	
63.8(d)	No	
63.8(e) (1)–(4)	Yes	
63.8(e)(5)(i)	Yes	
63.8(e)(5)(ii)	No	The standards in subpart GG do not include opacity standards.
63.8(f)(1)	Yes	
63.8(f)(2) (i)–(vii)	Yes	
63.8(f)(2)(viii)	No	The standards in subpart GG do not include opacity standards.
63.8(f)(2)(ix)	Yes	
63.8(f) (3)–(6)	Yes	
63.8(g)	Yes	
63.9(a)	Yes	
63.9(b)(1)	Yes	
63.9(b)(2)	Yes	§ 63.753(a)(1) requires submittal of the initial notification at least 1 year prior to the compliance date; § 63.753(a)(2) allows a title V or part 70 permit application to be substituted for the initial notification in certain circumstances.
63.9(b)(3)	No	
63.9(b)(4)	No	
63.9(b)(5)	No	
63.9(c)	Yes	
63.9(d)	Yes	
63.9(e)	Yes	
63.9(f)	No	The standards in subpart GG do not include opacity standards.
63.9(g)(1)	No	
63.9(g)(2)	No	The standards in subpart GG do not include opacity standards.
63.9(g)(3)	No	
63.9(h) (1)–(3)	Yes	§ 63.753(a)(1) also specifies additional information to be included in the notification of compliance status.
63.9(h)(4)	No	Reserved.
63.9(h) (5)–(6)	Yes	
63.9(i)	Yes	
63.9(j)	Yes	
63.10(a)	Yes	
63.10(b)	Yes	
63.10(c)(1)	No	
63.10(c) (2)–(4)	No	Reserved.
63.10(c)(5)–(8)	No	
63.10(c)(9)	No	Reserved.
63.10(c) (10)–(13)	No	
63.10(c)(14)	No	§ 63.8(d) does not apply to this subpart.

TABLE 1 TO SUBPART GG.—GENERAL PROVISIONS APPLICABILITY TO SUBPART GG—Continued

Reference	Applies to affected sources in subpart GG	Comment
63.10(c)(15)	No	The standards in subpart GG do not include opacity standards.
63.10(d) (1)–(2)	Yes	
63.10(d)(3)	No	
63.10(d)(4)	Yes	The standards in subpart GG do not include opacity standards.
63.10(d)(5)	Yes	
63.10(e)(1)	No	
63.10(e)(2)(i)	No	
63.10(e)(2)(ii)	No	
63.10(e)(3)	No	The standards in subpart GG do not include opacity standards.
63.10(e)(4)	No	
63.10(f)	Yes	
63.11	Yes	
63.12	Yes	
63.13	Yes	
63.14	Yes	
63.15	Yes	

15. Appendix A of subpart GG is added to read as follows:

Appendix A to Subpart GG—Specialty Coating Definitions

Ablative coating—A coating that chars when exposed to open flame or extreme temperatures, as would occur during the failure of an engine casing or during aerodynamic heating. The ablative char surface serves as an insulative barrier, protecting adjacent components from the heat or open flame.

Adhesion promoter—A very thin coating applied to a substrate to promote wetting and form a chemical bond with the subsequently applied material.

Adhesive bonding primer—A primer applied in a thin film to aerospace components for the purpose of corrosion inhibition and increased adhesive bond strength by attachment. There are two categories of adhesive bonding primers: primers with a design cure at 250° F or below and primers with a design cure above 250° F.

Aerosol coating—A hand-held, pressurized, non-refillable container that expels an adhesive or a coating in a finely divided spray when a valve on the container is depressed.

Antichafe coating—A coating applied to areas of moving aerospace components that may rub during normal operations or installation.

Bearing Coating—A coating applied to an antifriction bearing, a bearing housing, or the area adjacent to such a bearing to facilitate bearing functions or to protect base material from excessive wear.

Bonding maskant—A temporary coating used to protect selected areas of aerospace parts from strong acid or alkaline solutions during processing for bonding.

Chemical agent-resistant coating (CARC)—An exterior topcoat designed to withstand exposure to chemical warfare agents or the decontaminants used on these agents.

Clear coating—A transparent coating usually applied over a colored opaque coating, metallic substrate, or placard to give improved gloss and protection to the color coat. In some cases, a clearcoat refers to any transparent coating without regard to substrate.

Commercial exterior aerodynamic structure primer—A primer used on aerodynamic components and structures that protrude from the fuselage, such as wings and attached components, control surfaces, horizontal stabilizers, vertical fins, wing-to-body fairings, antennae, and landing gear and doors, for the purpose of extended corrosion protection and enhanced adhesion.

Commercial interior adhesive—Materials used in the bonding of passenger cabin interior components. These components must meet the FAA fireworthiness requirements.

Compatible Substrate Primer—Includes two categories: Compatible Epoxy Primer and Adhesive Primer. **Compatible Epoxy Primer** is primer that is compatible with the filled elastomeric coating and is epoxy based. The compatible substrate primer is an epoxy-polyamide primer used to promote adhesion of elastomeric coatings such as impact-resistant coatings. **Adhesive Primer** is a coating that (1) inhibits corrosion and serves as a primer applied to bare metal surfaces or prior to adhesive application, or (2) is applied to surfaces that can be expected to contain fuel. Fuel tank coatings are excluded from this category.

Conformal Coating—Coating applied to electrical conductors and circuit boards to protect them against electrical discharge, damage, and/or corrosion.

Corrosion prevention system—A coating system that provides corrosion protection by displacing water and penetrating mating surfaces, forming a protective barrier between the metal surface and moisture. Coatings containing oils or waxes are excluded from this category.

Critical use and line sealer maskant—A temporary coating, not covered under other maskant categories, used to protect selected

areas of aerospace parts from strong acid or alkaline solutions such as those used in anodizing, plating, chemical milling and processing of magnesium, titanium, high-strength steel, high precision aluminum chemical milling of deep cuts, and aluminum chemical milling of complex shapes.

Materials used for repairs or to bridge gaps left by scribing operations (i.e. line sealer) are also included in this category.

Cryogenic flexible primer—A primer designed to provide corrosion resistance, flexibility, and adhesion of subsequent coating systems when exposed to loads up to and surpassing the yield point of the substrate at cryogenic temperatures (–275° F and below).

Cryoprotective coating—A coating that insulates cryogenic or subcooled surfaces to limit propellant boil-off, maintain structural integrity of metallic structures during ascent or re-entry, and prevent ice formation.

Cyanoacrylate adhesive—A fast-setting, single component adhesive that cures at room temperature. Also known as “super glue.”

Dry Lubricative Coating—A coating consisting of lauric acid, cetyl alcohol, waxes, or other non-cross linked or resin-bound materials that act as dry lubricants.

Electric or radiation-effect coating—A coating or coating system engineered to interact, through absorption or reflection, with specific regions of the electromagnetic energy spectrum, such as the ultraviolet, visible, infrared, or microwave regions. Uses include, but are not limited to, lightning strike protection, electromagnetic pulse (EMP) protection, and radar avoidance. Coatings that have been designated “classified” by the Department of Defense are exempt.

Electrostatic discharge and electromagnetic interference (EMI) coating—A coating applied to space vehicles, missiles, aircraft radomes, and helicopter blades to disperse static energy or reduce electromagnetic interference.

Elevated temperature skydrol resistant commercial primer—A primer applied

primarily to commercial aircraft (or commercial aircraft adapted for military use) that must withstand immersion in phosphate-ester (PE) hydraulic fluid (Skydrol 500b or equivalent) at the elevated temperature of 150°F for 1,000 hours.

Epoxy polyamide topcoat—A coating used where harder films are required or in some areas where engraving is accomplished in camouflage colors.

Fire-resistant (interior) coating—For civilian aircraft, fire-resistant interior coatings are used on passenger cabin interior parts that are subject to the FAA fireworthiness requirements. For military aircraft, fire-resistant interior coatings are used on parts subject to the flammability requirements of MIL-STD-1630A and MIL-A-87721. For space applications, these coatings are used on parts subject to the flammability requirements of SE-R-0006 and SSP 30233.

Flexible primer—A primer that meets flexibility requirements such as those needed for adhesive bond primed fastener heads or on surfaces expected to contain fuel. The flexible coating is required because it provides a compatible, flexible substrate over bonded sheet rubber and rubber-type coatings as well as a flexible bridge between the fasteners, skin, and skin-to-skin joints on outer aircraft skins. This flexible bridge allows more topcoat flexibility around fasteners and decreases the chance of the topcoat cracking around the fasteners. The result is better corrosion resistance.

Flight test coating—A coating applied to aircraft other than missiles or single-use aircraft prior to flight testing to protect the aircraft from corrosion and to provide required marking during flight test evaluation.

Fuel tank adhesive—An adhesive used to bond components exposed to fuel and that must be compatible with fuel tank coatings.

Fuel tank coating—A coating applied to fuel tank components to inhibit corrosion and/or bacterial growth and to assure sealant adhesion in extreme environmental conditions.

High temperature coating—A coating designed to withstand temperatures of more than 350°F.

Insulation covering—Material that is applied to foam insulation to protect the insulation from mechanical or environmental damage.

Intermediate release coating—A thin coating applied beneath topcoats to assist in removing the topcoat in depainting operations and generally to allow the use of less hazardous depainting methods.

Lacquer—A clear or pigmented coating formulated with a nitrocellulose or synthetic resin to dry by evaporation without a chemical reaction. Lacquers are resolvable in their original solvent.

Metalized epoxy coating—A coating that contains relatively large quantities of metallic pigmentation for appearance and/or added protection.

Mold release—A coating applied to a mold surface to prevent the molded piece from sticking to the mold as it is removed.

Non-structural adhesive—An adhesive that bonds non-load bearing aerospace

components in non-critical applications and is not covered in any other specialty adhesive categories.

Optical anti-reflection coating—A coating with a low reflectance in the infrared and visible wavelength ranges, which is used for anti-reflection on or near optical and laser hardware.

Part marking coating—Coatings or inks used to make identifying markings on materials, components, and/or assemblies. These markings may be either permanent or temporary.

Pretreatment coating—An organic coating that contains at least 0.5 percent acids by weight and is applied directly to metal surfaces to provide surface etching, corrosion resistance, adhesion, and ease of stripping.

Protective oils/waxes—Any material containing oils or waxes that is used as a temporary coating to provide corrosion protection by displacing water during manufacturing, storage, and transportation.

Rain erosion-resistant coating—A coating or coating system used to protect the leading edges of parts such as flaps, stabilizers, radomes, engine inlet nacelles, etc. against erosion caused by rain impact during flight.

Rocket motor bonding adhesive—An adhesive used in rocket motor bonding applications.

Rocket motor nozzle coating—A catalyzed epoxy coating system used in elevated temperature applications on rocket motor nozzles.

Rubber-based adhesive—Quick setting contact cements that provide a strong, yet flexible, bond between two mating surfaces that may be of dissimilar materials.

Scale inhibitor—A coating that is applied to the surface of a part prior to thermal processing to inhibit the formation of scale.

Screen print ink—Inks used in screen printing processes during fabrication of decorative laminates and decals.

Seal coat maskant—An overcoat applied over a maskant to improve abrasion and chemical resistance during production operations.

Sealant—A material used to prevent the intrusion of water, fuel, air, or other liquids or solids from certain areas of aerospace vehicles or components. There are two categories of sealants: extrudable/rollable/brushable sealants and sprayable sealants.

Silicone insulation material—Insulating material applied to exterior metal surfaces for protection from high temperatures caused by atmospheric friction or engine exhaust. These materials differ from ablative coatings in that they are not "sacrificial."

Solid film lubricant—A very thin coating consisting of a binder system containing as its chief pigment material one or more of the following: molybdenum, graphite, polytetrafluoroethylene (PTFE), or other solids that act as a dry lubricant between faying surfaces.

Space vehicle coating—A coating applied to vehicles, assemblies, and components designed to travel beyond the limit of the earth's atmosphere.

Specialized function coating—Coatings that fulfill extremely specific engineering requirements that are limited in application and are characterized by low volume usage.

This category excludes coatings covered in other Specialty Coating categories.

Structural autoclavable adhesive—An adhesive used to bond load carrying aerospace components that is cured by heat and pressure in an autoclave.

Structural non-autoclavable adhesive—An adhesive cured under ambient conditions that is used to bond load carrying aerospace components or for other critical functions, such as non-structural bonding in the proximity of engines.

Temporary protective coating—A coating applied to provide scratch or corrosion protection during manufacturing, storage, or transportation. Two types include peelable protective coatings and alkaline removable coatings. These materials are not intended to protect against strong acid or alkaline solutions. Coatings that provide this type of protection from chemical processing are not included in this category.

Thermal control coating—Coatings formulated with specific thermal conductive or radiative properties to permit temperature control of the substrate.

Touch-up and Repair Coating—A coating used to cover minor coating imperfections appearing after the main coating operation.

Wing coating—A corrosion-resistant topcoat that is resilient enough to withstand the flexing of the wings.

16. Appendix A to Part 63 is amended by adding method 319 in numerical order to read as follows:

Appendix A to Part 63—Test Methods

* * * * *

Method 319: Determination of Filtration Efficiency for Paint Overspray Arrestors

1.0 Scope and Application

1.1 This method applies to the determination of the initial, particle size dependent, filtration efficiency for paint arrestors over the particle diameter range from 0.3 to 10 µm. The method applies to single and multiple stage paint arrestors or paint arrestor media. The method is applicable to efficiency determinations from 0 to 99 percent. Two test aerosols are used— one liquid-phase and one solid-phase. Oleic acid, a low volatility liquid (CAS Number 112-80-1), is used to simulate wet paint overspray. The solid-phase aerosol is potassium chloride salt (KCl, CAS Number 7447-40-7) and is used to simulate a dry overspray. The method is limited to determination of the initial, clean condition of the arrestor. Changes in efficiency (either increase or decrease) due to the accumulation of paint overspray on and within the arrestor are not evaluated.

1.2 Efficiency is defined as 1 – Penetration (e.g., 70 percent efficiency is equal to 0.30 penetration). Penetration is based on the ratio of the downstream particle concentration to the upstream concentration. It is often more useful, from a mathematical or statistical point of view, to discuss the upstream and downstream counts in terms of penetration rather than the derived efficiency value. Thus, this document uses both penetration and efficiency as appropriate.

2.0 Summary of Method

2.1 This method applies to the determination of the fractional (i.e., particle size dependent) aerosol penetration of several types of paint arrestors. Fractional penetration is computed from aerosol concentrations measured upstream and downstream of an arrestor installed in a laboratory test rig. The aerosol concentrations upstream and downstream of the arrestors are measured with an aerosol analyzer that simultaneously counts and sizes the particles in the aerosol stream. The aerosol analyzer covers the particle diameter size range from 0.3 to 10 μm in a minimum of 12 contiguous sizing channels. Each sizing channel covers a narrow range of particle diameters. For example, Channel 1 may cover from 0.3 to 0.4 μm , Channel 2 from 0.4 to 0.5 μm , * * * By taking the ratio of the downstream to upstream counts on a channel by channel basis, the penetration is computed for each of the sizing channels.

2.2 The upstream and downstream aerosol measurements are made while injecting the test aerosol into the air stream upstream of the arrestor (ambient aerosol is removed with HEPA filters on the inlet of the test rig). This test aerosol spans the particle size range from 0.3 to 10 μm and provides sufficient upstream concentration in each of the OPC sizing channels to allow accurate calculation of penetration, down to penetrations of approximately 0.01 (i.e., 1 percent penetration; 99 percent efficiency). Results are presented as a graph and a data table showing the aerodynamic particle diameter and the corresponding fractional efficiency.

3.0 Definitions

Aerodynamic Diameter—diameter of a unit density sphere having the same aerodynamic properties as the particle in question.

$\text{Efficiency} = 1 - \text{Penetration}$.

Optical Particle Counter (OPC)—an instrument that counts particles by size using light scattering. An OPC gives particle diameters based on size, index of refraction, and shape.

Penetration—the fraction of the aerosol that penetrates the filter at a given particle diameter. Penetration equals the downstream concentration divided by the upstream concentration.

4.0 Interferences

4.1 The influence of the known interferences (particle losses) are negated by correction of the data using blanks.

5.0 Safety

5.1 There are no specific safety precautions for this method above those of good laboratory practice. This standard does not purport to address all of the safety problems, if any, associated with its use. It is the responsibility of the user of this method to establish appropriate safety and health practices and determine the applicability of regulatory limitations prior to use.

6.0 Equipment and Supplies

6.1 **Test Facility.** A schematic diagram of a test duct used in the development of the method is shown in Figure 319-1.

6.1.1 The test section, paint spray section, and attached transitions are constructed of stainless and galvanized steel. The upstream and downstream ducting is 20 cm diameter PVC. The upstream transition provides a 7° angle of expansion to provide a uniform air flow distribution to the paint arrestors. Aerosol concentration is measured upstream and downstream of the test section to obtain the challenge and penetrating aerosol concentrations, respectively. Because the downstream ducting runs back under the test section, the challenge and penetrating aerosol

taps are located physically near each other, thereby facilitating aerosol sampling and reducing sample-line length. The inlet nozzles of the upstream and downstream aerosol probes are designed to yield isokinetic sampling conditions.

6.1.2 The physical dimensions of the test duct can deviate from those of Figure 319-1 provided that the following key elements are maintained: the test duct must meet the criteria specified in Table 319-1; the inlet air is HEPA-filtered; the blower discharges into the test duct thereby creating a positive pressure in the duct relative to the surrounding room; the challenge air has a temperature between 60 and 80°F and a relative humidity of less than 70 percent; the angle of the upstream transition (if used) to the paint arrestor must not exceed 7°; the angle of the downstream transition (if used) from the paint arrestor must not exceed 30°; the test duct must provide a means for mixing the challenge aerosol with the upstream flow (in lieu of any mixing device, a duct length of 30 duct diameters fulfills this requirement); the test duct must provide a means for mixing any penetrating aerosol with the downstream flow (in lieu of any mixing device, a duct length of 30 duct diameters fulfills this requirement); the test section must provide a secure and leak-free mounting for single and multiple stage arrestors; the test duct must utilize a 180° bend in the downstream duct; the test duct must be in straight centerline alignment from the point of aerosol injection to the upstream end of the 180° bend; the test duct must be in straight centerline alignment from the downstream end of the 180° bend to the downstream aerosol sample probe; and the upstream and downstream aerosol sampling probes must be located directly opposite each other (within a tolerance of 12-inches).

BILLING CODE 6560-50-P

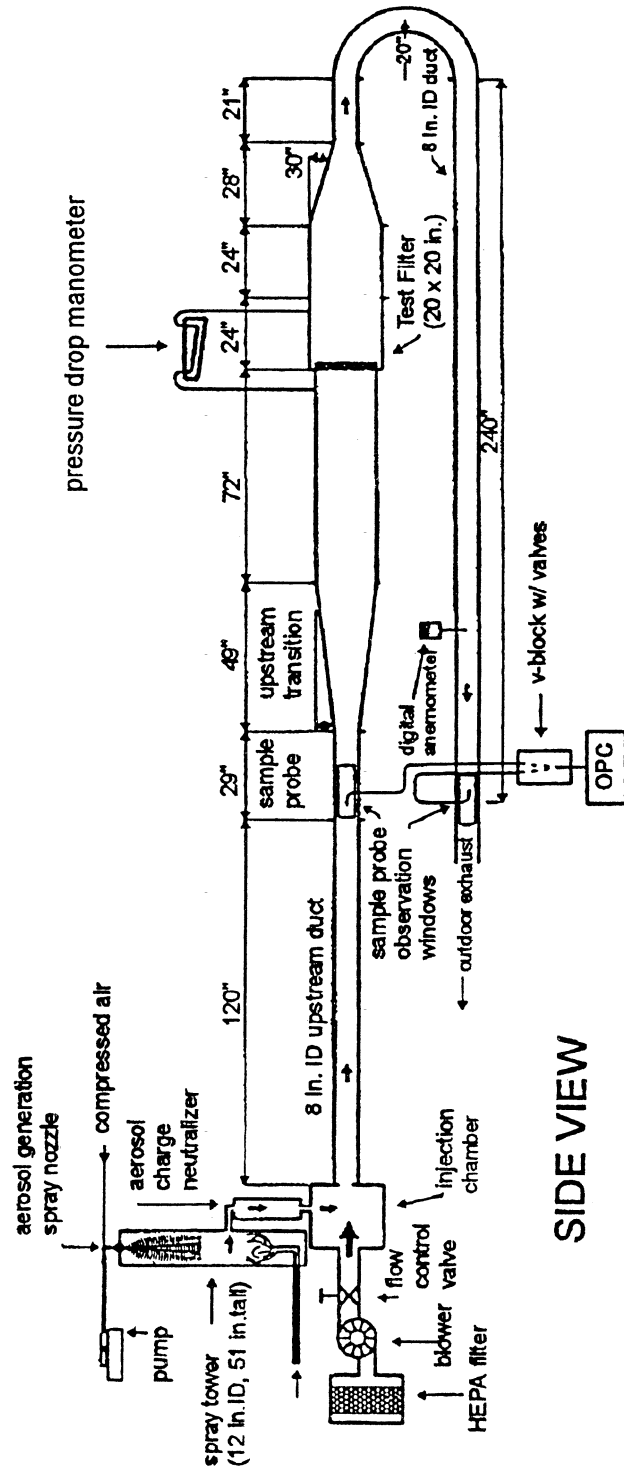

Figure 319-1. Schematic illustration of the fractional efficiency test rig.

TABLE 319-1.—QC CONTROL LIMITS

	Frequency and description	Control limits
OPC zero count	Each Test. OPC samples HEPA-filtered air	<50 counts per minute.
OPC sizing accuracy check	Daily. Sample aerosolized PSL spheres	Peak of distribution should be in correct OPC channel.
Minimum counts per channel for challenge aerosol.	Each Test	Minimum total of 500 particle counts per channel.
Maximum particle concentration	Each Test. Needed to ensure OPC is not overloaded	<20/cc based on cumulative count >0.3 μm diameter.
Standard Deviation of Penetration	Computed for each test based on the CV of the upstream and downstream counts.	<0.10 for 0.3–5 μm diameter; <0.30 for >5 μm diameter.
0% Penetration	Monthly	<0.01
100% Penetration—Kcl	Triplicate tests performed immediately before, during, or after triplicate arrestor tests.	0.3–1 >0.95; 1–3 >0.75; 3–10 >0.50.
100% Penetration—Oleic Acid	Triplicate tests performed immediately before, during, or after triplicate arrestor tests.	0.3–1 >0.95; 1–3 >0.75; 3–10 >0.50.

6.2 Aerosol Generator. The aerosol generator is used to produce a stable aerosol covering the particle size range from 0.3 to 10 μm diameter. The generator used in the development of this method consists of an air atomizing nozzle positioned at the top of a 0.30-m (12-in.) diameter, 1.3-m (51-in) tall, acrylic, transparent, spray tower. This tower allows larger sized particles, that would otherwise foul the test duct and sample lines, to fall out of the aerosol. It also adds drying air to ensure that the KCl droplets dry to solid salt particles. After generation, the aerosol passes through an aerosol neutralizer (Kr85 radioactive source) to neutralize any electrostatic charge on the aerosol (electrostatic charge is an unavoidable consequence of most aerosol generation methods). To improve the mixing of the aerosol with the air stream, the aerosol is injected counter to the airflow. Generators of other designs may be used, but they must produce a stable aerosol concentration over the 0.3 to 10 μm diameter size range; provide a means of ensuring the complete drying of the KCl aerosol; and utilize a charge neutralizer to neutralize any electrostatic charge on the aerosol. The resultant challenge aerosol must meet the minimum count per channel and maximum concentration criteria of Table 319-1.

6.3 Frame Dimensions. To secure the arrestor or arrestor media in the test duct, a

mounting frame is necessary. The frame is used to seal the arrestor into the rig to prevent aerosol laden air bypassing the arrestor. Since arrestor media are often sold unmounted, the frame must provide back support for the media in addition to sealing into the rig. The test frame for the 20" × 20" test rig has internal dimensions of 18 1/4" square and a removable wire rod back support. The wire support is used for media with insufficient internal support.

6.4 Optical Particle Counter. The upstream and downstream aerosol concentrations are measured with a high resolution optical particle counter (OPC). To ensure comparability of test results, the OPC utilize an optical design based white-light wide-angle forward light scattering encompassing the angles from 15° to 150° with respect to the incident light and provide a minimum of 12 contiguous particle sizing channels from 0.3 to 10 μm diameter (based on response to PSL) where, for each channel, the ratio of the diameter corresponding to the upper channel bound to the lower channel bound must not exceed 1.5.

6.5 Aerosol Sampling System. The upstream and downstream sample lines must be made of rigid electrically-grounded metallic tubing having a smooth inside surface, and they must be rigidly secured to prevent movement during testing. The upstream and downstream sample lines are

to be nominally identical in geometry. The use of a short length (50 mm maximum) of straight flexible electrically-dissipative tubing to make the final connection to the OPC is acceptable. The inlet nozzles of the upstream and downstream probes must be sharp-edged and of appropriate entrance diameter to maintain isokinetic sampling within 10 percent of the air velocity. The system must be designed to allow repeated sequential upstream—downstream sampling. Sufficient time must be allowed between each upstream to downstream and downstream to upstream switch to minimize cross contamination in the resultant OPC measurement (verified per 11.3).

6.6 Airflow Monitor. The volumetric airflow through the system may be measured with a calibrated orifice flow nozzle or by use of a velocity probe. If a velocity probe is used, traverse measurements (Figure 319-2) across the duct (12-point equal area traverse for round ducts, 9-point equal area traverse for square ducts) must be performed to allow accurate determination of volumetric flow (i.e. average velocity × cross sectional area of duct). The flow orifice and velocity probe must have an accuracy of 5 percent or better. The resolution of the velocity probe must be 5 percent of reading or better.

BILLING CODE 6560-50-P

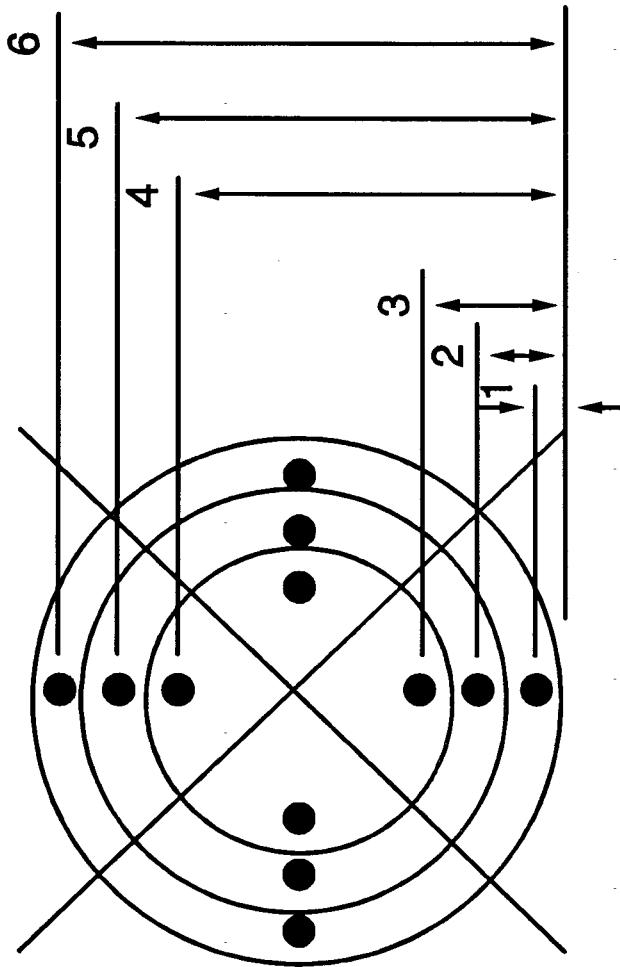

Traverse Point	Distance % of diameter
1	4.4
2	14.7
3	29.5
4	70.5
5	86.3
6	95.6

Figure 319-2. Location of traverse points in circular duct.

7.0 Reagents and Standards.

7.1 The liquid test aerosol is reagent grade, 98 percent pure, oleic acid (Table 319–

2). The solid test aerosol is KCl aerosolized from a solution of 20 percent KCl in water. In addition to the test aerosol, a calibration

aerosol of monodisperse polystyrene latex (PSL) spheres are used to verify the calibration of the OPC.

TABLE 319–2.—PROPERTIES OF THE TEST AND CALIBRATION AEROSOLS

	Refractive index	Density, g/cm ³	Shape
Oleic Acid (liquid-phase challenge aerosol)	1.46 non absorbing	0.89	Spherical.
KCl (solid-phase challenge aerosol)	1.49	1.98	Cubic or agglomerated cubes.
PSL (calibration aerosol)	1.59 nonabsorbing	1.05	Spherical.

8.0 Sample Collection, Preservation, and Storage

8.1 In this test, all sampling occurs in real-time, thus no samples are collected that require preservation or storage during the test. The paint arrestors are shipped and stored to avoid structural damage or soiling. Each arrestor may be shipped in its original

box from the manufacturer or similar cardboard box. Arrestors are stored at the test site in a location that keeps them clean and dry. Each arrestor is clearly labeled for tracking purposes.

9.0 Quality Control

9.1 Table 319–1 lists the QC control limits.

9.2 The standard deviation (σ) of the penetration (P) for a given test at each of the 15 OPC sizing channels is computed from the coefficient of variation (CV, the standard deviation divided by the mean) of the upstream and downstream measurements as:

$$\sigma_p = P \sqrt{(CV_{upstream}^2 + CV_{downstream}^2)} \quad (\text{Eq. 319-1})$$

For a properly operating system, the standard deviation of the penetration is < 0.10 at particle diameters from 0.3 to 5 μm and less than 0.30 at diameters > 5 μm .

9.3 Data Quality Indicators. Data Quality Objectives (DQO).

9.3.1 Fractional Penetration. From the triplicate tests of each paint arrestor model,

the standard deviation for the penetration measurements at each particle size (i.e., for each sizing channel of the OPC) is computed as:

$$s = \left[\sum (P_i - \bar{P})^2 / (n - 1) \right]^{1/2} \quad (\text{Eq. 319-2})$$

Where P_i represents an individual penetration measurement, and \bar{P} the average of the 3 ($n = 3$) individual measurements.

9.3.2 Bias of the fractional penetration values is determined from triplicate no-filter and HEPA filter tests. These tests determine the measurement bias at 100 percent penetration and 0 percent penetration, respectively.

9.3.3 PSL-Equivalent Light Scattering Diameter. The precision and bias of the OPC sizing determination are based on sampling three known diameter sizes of PSL and noting whether the particle counts peak in the correct channel of the OPC. This is a pass/fail measurement with no calculations involved.

9.3.4 Flow Velocity. The precision of the measurement is 5 percent of the set point as read with the thermal anemometer. The maximum acceptable bias is 20 percent based on a comparison of the thermal anemometer to pitot tube readings.

10.0 Calibration and Standardization

10.1 Optical Particle Counter. The OPC must have an up-to-date factory calibration (i.e., calibrated within prior 6 months). Check the OPC zero at the beginning and end of each test by sampling HEPA-filtered air. Verify the sizing accuracy at the beginning of the measurement program with three sizes of PSL spheres and then on a daily basis (for days when tests are performed) with 1-size PSL spheres.

10.2 Flow Velocity. Airflow orifice plates and velocity probes must have an accuracy of 5 percent or better. Manometers used in conjunction with the orifice plate must be inspected prior to use for proper level, zero, and mechanical integrity. Tubing connections to the manometer must be free from kinks and have secure connections.

10.3 Pressure Drop. Measure pressure drop across the paint arrestor with an inclined manometer readable to within 0.01 in. H₂O. Prior to use, the level and zero of the manometer, and all tubing connections, must be inspected and adjusted as needed.

11.0 Procedure

11.1 Filtration Efficiency. For both the oleic acid and KCl challenges, this procedure is performed in triplicate using a new arrestor for each test.

11.1.1 General Information and Test Duct Preparation

11.1.1.1 Use the "Test Run Sheet" form (Figure 319–3) to record the test information.

11.1.1.2 Record the date, time, test operator, Test #, paint arrestor brand/model and its assigned ID number. For tests with no arrestor, record none.

11.1.1.3 Ensure that the arrestor is undamaged and is in "new" condition.

11.1.1.4 Mount the arrestor in the appropriate frame. Inspect for any airflow leak paths.

Run Sheet

Part 1. General Information

Date and Time: _____ Test Operator: _____ Test #:

Paint Arrestor: Brand/Model

Arrestor Assigned ID # _____

Condition of arrestor (i.e., is there any damage? Must be new condition to proceed):

Manometer zero and level confirmed?

Part 2. Clean Efficiency Test

Date and Time: _____

Optical Particle 20 min. warm up

Counter:

Zero count (<50 counts/min) _____

Daily PSL check _____ PSL Diam: _____ μm

File name for OPC data: _____

Test Conditions:

Air Flow: _____

Temp & RH: Temp _____ F RH

Atm. Pressure: _____ inch Hg (from mercury barometer)

Aerosol Generator:

Record all Operating

Parameters

Test Aerosol:

(Oleic acid or KCl) _____

Arrestor:

Pressure drop: at start _____ inch

H₂O at end _____ inch H₂O

Condition of arrestor at end of test (note any phys. deterioration)

Figure 319-3. Test run sheet

11.1.1.5 Install frame-mounted arrestor in the test duct. Remove the downstream window and examine the installed arrestor to verify that it is sealed in the duct. For tests with no arrestor, install the empty frame.

11.1.1.6 Visually confirm the manometer zero and level. Adjust as needed.

11.1.2 Clean Efficiency Test

11.1.2.1 Record the date and time upon beginning this section.

11.1.2.2 Optical Particle Counter

11.1.2.2.1 General: Operate the OPC per the manufacturer's instructions allowing a minimum of 20 minutes warm up before making any measurements.

11.1.2.2.2 Overload: The OPC will yield inaccurate data if the aerosol concentration it is attempting to measure exceeds its operating limit. To ensure reliable measurements, the maximum aerosol concentration will not exceed 10 percent of the manufacturer's claimed concentration limit. If this value is exceeded, reduce the aerosol concentration until the acceptable conditions are met.

11.1.2.2.3 Zero Count: Connect a HEPA capsule to the inlet of the OPC and obtain printouts for three samples (each a minimum of 1-minute each). Record maximum cumulative zero count. If the count rate exceeds 50 counts per minute, the OPC requires servicing before continuing.

11.1.2.2.4 PSL Check of OPC Calibration: Confirm the calibration of the OPC by sampling a known size PSL aerosol. Aerosolize the PSL using an appropriate nebulizer. Record whether the peak count is observed in the proper channel. If the peak is not seen in the appropriate channel, have the OPC recalibrated.

11.1.2.3 Test Conditions:

11.1.2.3.1 Airflow: The test airflow corresponds to a nominal face velocity of 120 FPM through the arrestor. For arrestors having nominal 20" × 20" face dimensions, this measurement corresponds to an airflow of 333 cfm. For arrestors having nominal face dimensions of 24" × 24", this measurement corresponds to an airflow of 480 cfm.

11.1.2.3.2 Temperature and Relative Humidity: The temperature and relative humidity of the challenge air stream will be measured to within an accuracy of ±2°F and ±5 percent RH. To protect the probe from fouling, it may be removed during periods of aerosol generation.

11.1.2.3.3 Barometric Pressure: Use a mercury barometer. Record the atmospheric pressure.

11.1.2.4 Upstream and Downstream Background Counts

11.1.2.4.1 With the arrestor installed in the test duct and the airflow set at the proper value, turn on the data acquisition computer and bring up the data acquisition program.

11.1.2.4.2 Set the OPC settings for the appropriate test sample duration with output for both printer and computer data collection.

11.1.2.4.3 Obtain 1 set of upstream-downstream background measurements.

11.1.2.4.4 After obtaining the upstream-downstream measurements, stop data acquisition.

11.1.2.5 Efficiency Measurements:

11.1.2.5.1 Record the arrestor pressure drop.

11.1.2.5.2 Turn on the Aerosol Generator. Begin aerosol generation and record the operating parameters.

11.1.2.5.3 Monitor the particle counts. Allow a minimum of 10 minutes for the generator to stabilize.

11.1.2.5.4 Confirm that the total particle count does not exceed the predetermined upper limit. Adjust generator as needed.

11.1.2.5.5 Confirm that a minimum of 50 particle counts are measured in the upstream sample in each of the OPC channels per sample. Adjust generator or sample time as needed.

11.1.2.5.6 If you are unable to obtain a stable concentration within the concentration limit and with the 50 count minimum per channel, adjust the aerosol generator.

11.1.2.5.7 When the counts are stable, perform repeated upstream-downstream sequential sampling until 10 upstream-downstream measurements are obtained. (Note, begin data acquisition with upstream sampling.)

11.1.2.5.8 After collection of the 10 upstream-downstream samples, stop data acquisition and allow 2 more minutes for final purging of generator.

11.1.2.5.9 Obtain 1 additional set of upstream-downstream background samples.

11.1.2.5.10 After obtaining the upstream-downstream background samples, stop data acquisition.

11.1.2.5.11 Record the arrestor pressure drop.

11.1.2.5.12 Turn off blower.

11.1.2.5.13 Remove the paint arrestor assembly from the test duct. Note any signs of physical deterioration.

11.1.2.5.14 Remove the arrestor from the frame and place the arrestor in an appropriate storage bag.

11.2 Control Test: 100 Percent Penetration Test. Three 100 percent penetration tests must be performed as part

of each test series. These tests are performed with no arrestor installed in the test housing. This test is relatively stringent test of the adequacy of the overall duct, sampling, measurement, and aerosol generation system. The test is performed as a normal penetration test except the paint arrestor is not used. A perfect system would yield a measured penetration of 1 at all particle sizes. Deviations from 1 can occur due to particle losses in the duct, differences in the degree of aerosol uniformity (i.e., mixing) at the upstream and downstream probes, and differences in particle transport efficiency in the upstream and downstream sampling lines.

11.3 Control Test: 0 Percent Penetration. One 0 percent penetration test must be performed as part of each test series. The test is performed by using a HEPA filter rather than a paint arrestor. This test assesses the adequacy of the instrument response time and sample line lag.

12.0 Data Analysis and Calculations

12.1 Analysis. The analytical procedures for the fractional penetration and flow velocity measurements are described in Section 11. Note that the primary measurement, that of the upstream and downstream aerosol concentrations, are performed with the OPC which acquires the sample and analyzes it in real time. Because all the test data is collected in real time, there are no analytical procedures performed subsequent to the actual test, only data analysis.

12.2 Calculations

12.2.1 Penetration

Nomenclature

U=Upstream particle count

D=Downstream particle count

U_b=Upstream background countD_b=Downstream background countP₁₀₀=100 percent penetration value determined in triplicate no filter testsP=Penetration corrected for P₁₀₀

σ=Sample standard deviation

CV=Coefficient of variation=σ/mean

E=Efficiency.

Overbar denotes arithmetic mean of quantity.

Analysis of each test involves the following quantities:

- P₁₀₀ value for each sizing channel from the no filter tests.
- 2 upstream background values.
- 2 downstream background values.
- 10 upstream values with aerosol generator on, and
- 10 downstream values with aerosol generator on.

Using the values associated with each sizing channel, the

$$P = \left\{ \frac{(\bar{D} - \bar{D}_b)}{(\bar{U} - \bar{U}_b)} \right\} / P_{100} \quad (\text{Eq. 319-3})$$

$$E = 1 - P \quad (\text{Eq. 319-4})$$

penetration associated with each particle sizing channel is calculated as:

Most often, the background levels are small compared to the values when the aerosol generator is on.

12.3 The relationship between the physical diameter (D_{Physical}) as measured by the OPC to the aerodynamic diameter (D_{Aero}) is given by:

$$D_{\text{Aero}} = D_{\text{Physical}} \sqrt{\frac{\rho_{\text{Particle}}}{\rho_o} \frac{\text{CCF}_{\text{Physical}}}{\text{CCF}_{\text{Aero}}}} \quad (\text{Eq. 319-5})$$

Where:

ρ_o =unit density of 1 g/cm³.

ρ_{Particle} =the density of the particle, 0.89 g/cm³ for oleic acid.

$\text{CCF}_{\text{Physical}}$ =the Cunningham Correction Factor at D_{Physical} .

CCF_{Aero} =the Cunningham Correction Factor at D_{Aero} .

12.4 Presentation of Results. The test results must be presented in both graphical and tabular form.

12.4.1 The X-axis of the graph will be a logarithmic scale of aerodynamic diameter from 0.1 to 100 μm . The Y-axis will be Penetration on a linear scale from 0 to 1. Plots for each individual run and a plot of the average of triplicate solid-phase and of the average triplicate liquid-phase tests must be prepared. All plots are to be based on point-to-point plotting (i.e., no curve fitting is to be used). The data are to be plotted based on the geometric mean diameter of each of the OPC's sizing channels.

12.4.2 Tabulated data from each test must be provided. The data must include the upper and lower diameter bound and geometric mean diameter of each of the OPC sizing channels, the background particle counts for each channel for each sample, the upstream particle counts for each channel for each sample, the downstream particle counts for each channel for each sample, the 100 percent penetration values computed for each channel, and the 0 percent penetration values computed for each channel.

13.0 Pollution Prevention

13.1 The quantities of materials to be aerosolized should be prepared in accord with the amount needed for the current tests so as to prevent wasteful excess.

14.0 Waste Management

14.1 Paint arrestors may be returned to originator, if requested, or disposed of with regular laboratory waste.

15.0 References

1. Hanley, J.T., D.D. Smith and L. Cox. "Fractional Penetration of Paint Overspray Arrestors, Draft Final Report." EPA Cooperative Agreement CR-817083-01-0, January 1994.
2. Hanley, J.T., D.D. Smith, and D.S. Ensor. "Define a Fractional Efficiency Test Method that is Compatible with Particulate Removal Air Cleaners Used in General Ventilation," Final Report, 671-RP, American Society of Heating, Refrigerating, and Air-Conditioning Engineers, Inc., December 1993.
3. "Project Work and Quality Assurance Plan: Fractional Penetration of Paint Overspray Arrestors, Category II," EPA Cooperative Agreement No. CR-817083, July 1994.

[FR Doc. 96-27307 Filed 10-28-96; 8:45 am]

BILLING CODE 6560-50-P