

provide the public with any necessary policy and practices for the administration of recreation program through procedural guidance.

**EFFECTIVE DATE:** July 12, 1996.

**FOR FURTHER INFORMATION CONTACT:**  
Edna Taylor, (202) 452-5068.

**SUPPLEMENTARY INFORMATION:** This final regulation removes 43 CFR Part 8000—Recreation Programs from BLM's regulatory program as part of its effort to eliminate unnecessary and inappropriate material in the Code of Federal Regulations.

BLM published a proposed rule on the removal of 43 CFR Part 8000—Recreation Programs in the Federal Register of April 9, 1996 (61 FR 15753), requesting comments by May 9, 1996. During the 30-day comment period, BLM did not receive any comments.

This rule is not subject to the Office of Management and Budget review under Executive Order 12866.

BLM has determined that this final rule is categorically excluded from environmental review under section 102(2)(C) of the National Environmental Policy Act, pursuant to 516 Departmental Manual (DM), Chapter 2, Appendix I, Item 1.10, and that the final rule does not meet any of the 10 criteria for exceptions to categorical exclusion listed in 516 DM, Chapter 2, Appendix 2. Pursuant to Council on Environmental Quality regulations (40 CFR 1508.4) and the environmental policies and procedures of the Department of the Interior, the term "categorical exclusions" means a "category of actions that do not individually or cumulatively have a significant effect on the human environment and that have been found to have no such effect in procedures adopted by the Federal agency and for which neither an environmental assessment nor an environmental impact statement is required."

The final rule will not have a significant economic impact on a substantial number of small entities under the Regulatory Flexibility Act (5 U.S.C. 601 et seq.). The rule does not contain information collection requirements that need approval by the Office of Management and Budget under 44 U.S.C. 3501 et seq.

The principal author of this final rule is Edna Taylor, Regulatory Management Team, BLM.

Accordingly, under the authority of 5 U.S.C. 301, 43 CFR Part 8000—Recreation Programs is removed.

Dated: June 5, 1996.  
Sylvia V. Baca,  
*Acting Assistant Secretary of the Interior.*  
[FR Doc. 96-14846 Filed 6-11-96; 8:45 am]  
BILLING CODE 4310-84-P

### 43 CFR Part 8300

[WO-340-1220-00-24 1A]

RIN 1004-AC50

### Recreation Management

**AGENCY:** Bureau of Land Management, Interior.

**ACTION:** Final Rule; removal.

**SUMMARY:** This final rule removes 43 CFR Part 8300—Procedures regarding recreation management on public lands, in its entirety. 43 CFR Part 8300—Procedures contains no substantive material that is not repeated in subsequent sections of 43 CFR. The Bureau of Land Management (BLM) will provide the public with any necessary policy and practices for the administration of recreation program through procedural guidance.

**EFFECTIVE DATE:** July 12, 1996.

**FOR FURTHER INFORMATION CONTACT:**  
Edna Taylor, (202) 452-5068.

**SUPPLEMENTARY INFORMATION:** This final regulation removes 43 CFR Part 8300—Procedures from BLM's regulatory program as part of its effort to eliminate unnecessary and inappropriate material in the Code of Federal Regulations.

BLM published a proposed rule on the removal of 43 CFR Part 8300—Procedures in the Federal Register of April 9, 1996 (61 FR 15753), requesting comments by May 9, 1996. During the 30-day comment period, BLM did not receive any comments.

This rule is not subject to the Office of Management and Budget review under Executive Order 12866.

BLM has determined that this final rule is categorically excluded from environmental review under section 102(2)(C) of the National Environmental Policy Act, pursuant to 516 Departmental Manual (DM), Chapter 2, Appendix I, Item 1.10, and that the final rule does not meet any of the 10 criteria for exceptions to categorical exclusion listed in 516 DM, Chapter 2, Appendix 2. Pursuant to Council on Environmental Quality regulations (40 CFR 1508.4) and the environmental policies and procedures of the Department of the Interior, the term "categorical exclusions" means a "category of actions that do not individually or cumulatively have a significant effect on the human

environment and that have been found to have no such effect in procedures adopted by the Federal agency and for which neither an environmental assessment nor an environmental impact statement is required."

The final rule will not have a significant economic impact on a substantial number of small entities under the Regulatory Flexibility Act (5 U.S.C. 601 et seq.). The rule does not contain information collection requirements that need approval by the Office of Management and Budget under 44 U.S.C. 3501 et seq.

The principal author of this final rule is Edna Taylor, Regulatory Management Team, BLM.

Accordingly, under the authority of 5 U.S.C. 301, 43 CFR Part 8300—Procedures is removed.

Dated: June 5, 1996.  
Sylvia V. Baca,  
*Acting Assistant Secretary of the Interior.*  
[FR Doc. 96-14845 Filed 6-11-96; 8:45 am]  
BILLING CODE 4310-84-P

### FEDERAL COMMUNICATIONS COMMISSION

#### 47 CFR Parts 15, 22, 24, and 101

[WT Docket No. 95-157; RM-8643; FCC 96-196]

#### Microwave Facilities Operating in 1850-1990 MHz (2GHz) Band; Relocation Costs Sharing

**AGENCY:** Federal Communications Commission.

**ACTION:** Final rule.

**SUMMARY:** By this *First Report and Order*, the Commission changes and clarifies certain aspects of the microwave relocation rules adopted in our Emerging Technologies proceeding, ET Docket No. 92-9. The Commission also adopts a plan for sharing the costs of relocating microwave facilities currently operating in the 1850 to 1990 MHz ("2 GHz") band, which has been allocated for use by broadband Personal Communications Services ("PCS"). The Commission's plan establishes a mechanism whereby PCS licensees that incur costs to relocate microwave links receive reimbursement for a portion of those costs from other PCS licensees that also benefit from the resulting spectrum clearance. The Commission conditions the cost-sharing plan, however, on selection of one or more entities or organizations to administer the plan.

**EFFECTIVE DATES:** Sections 15.307 and 22.602 are effective August 12, 1996.

Sections 24.5, 24.237, 24.238, 24.239, 24.241, 24.243, 24.245, 24.247, 24.249, 24.251 and 24.253 will become effective August 12, 1996, and will become applicable on the date that the Wireless Telecommunications Bureau selects a clearinghouse to administer the cost-sharing plan. The Commission will publish a document announcing the selection of the clearinghouse at a later date. Sections 101.3, 101.69, 101.71, 101.73, 101.75, 101.77, 101.79, 101.81, and 101.147 will become effective August 1, 1996.

**FOR FURTHER INFORMATION CONTACT:**

Michael Hamra (202) 418-0620, Wireless Telecommunications Bureau.

**SUPPLEMENTARY INFORMATION:** This is a synopsis of the *First Report and Order*, adopted April 24, 1996 and released April 30, 1996. For information regarding the proposed plan for sharing the costs of microwave relocation, see Amendment to the Commission's Rules Regarding a Plan for Sharing the Costs of Microwave Relocation, *Notice of Proposed Rule Making*, WT Docket No. 95-157, 60 FR 55529 (November 1, 1995) ("*Cost-Sharing Notice*"). Part 101 will become effective August 1, 1996. See 61 FR 26670 (May 28, 1996). The complete text of this *First Report and Order* is available for inspection and copying during normal business hours in the FCC Reference Center, Room 230, 1919 M Street, N.W., Washington, D.C., and also may be purchased from the Commission's copy contractor, International Transcription Service, at (202) 857-3800, 2100 M Street, N.W., Suite 140, Washington, D.C. 20037.

**I. Background**

1. In the *First Report and Order and Third Notice of Proposed Rule Making* in ET Docket No. 92-9, 57 FR 49020 (October 29, 1992) the Commission reallocated the 1850-1990, 2110-2150, and 2160-2200 MHz bands from private and common carrier fixed microwave services to emerging technology services. The Commission also established procedures for 2 GHz microwave incumbents to be relocated to available frequencies in higher bands or to other media, by encouraging incumbents to negotiate voluntary relocation agreements with emerging technology licensees or manufacturers of unlicensed devices when frequencies used by the incumbent are needed to implement the emerging technology. *The First Report and Order* stated that, should negotiations fail, the emerging technology licensee could request involuntary relocation of the incumbent, provided that the emerging technology service provider pays the cost of

relocating the incumbent to a comparable facility. In the Commission's *Third Report and Order* in ET Docket No. 92-9, 58 FR 46547 (September 2, 1993) as modified on reconsideration by the *Memorandum Opinion and Order*, 59 FR 19642 (April 25, 1994) the Commission established additional details of the transition plan to enable emerging technology providers to relocate incumbent facilities. The relocation process consists of two negotiation periods that must expire before an emerging technology licensee may request involuntary relocation. The first is a fixed two-year period for voluntary negotiations—three years for public safety incumbents, e.g., police, fire, and emergency medical—commencing with the Commission's acceptance of applications for emerging technology services, during which the emerging technology providers and microwave licensees may negotiate any mutually acceptable relocation agreement. Negotiations are strictly voluntary. If no agreement is reached, the emerging technology licensee may initiate a one-year mandatory negotiation period—or two-year mandatory period if the incumbent is a public safety licensee—during which the parties are required to negotiate in good faith.

2. Should the parties fail to reach an agreement during the mandatory negotiation period, the emerging technology provider may request involuntary relocation of the existing facility. Involuntary relocation requires that the emerging technology provider (1) guarantee payment of all costs of relocating the incumbent to a comparable facility; (2) complete all activities necessary for placing the new facilities into operation, including engineering and frequency coordination; and (3) build and test the new microwave (or alternative) system. Once comparable facilities are made available to the incumbent microwave operator, the Commission will amend the 2 GHz license of the incumbent to secondary status. After relocation, the microwave incumbent is entitled to a one-year trial period to determine whether the facilities are indeed comparable, and if they are not, the emerging technology licensee must remedy the defects or pay to relocate the incumbent back to its former or an equivalent 2 GHz frequency.

3. Under these procedures, it is possible for a relocation agreement between a PCS licensee and a microwave incumbent to have spectrum-clearing benefits for other PCS licensees as well. First, some microwave spectrum blocks overlap with one or

more PCS blocks, because the spectrum in the 1850-1990 MHz band was assigned differently in the two services. Second, incumbents' receivers may be susceptible to adjacent or co-channel interference from PCS licensees in more than one PCS spectrum block. For example, a microwave link located partially in Block A, partially in Block D, and adjacent to Block B, may cause interference to or receive interference from PCS licensees that are licensed in each of those blocks. Third, because most 2 GHz microwave licensees operate multi-link systems, PCS licensees may be asked to relocate links that do not directly encumber their own spectrum or service area in order to obtain the microwave incumbent's voluntary consent to relocate. Finally, the *Unlicensed PCS Ad Hoc Committee for 2 GHz Microwave Transition and Management Inc.* ("*UTAM*"), the frequency coordinator for the PCS spectrum designated for unlicensed devices, expects that some licensed PCS providers will have to relocate links in the unlicensed band that are paired with links in licensed PCS spectrum. The Commission has designated UTAM to coordinate relocation in the 1910-1930 MHz band, which has been reallocated for unlicensed PCS devices. Once the 1910-1930 MHz band is clear, or there is little risk of interference to the remaining incumbents, and UTAM has recovered its relocation costs, UTAM's role will end and it will be dissolved.

4. Because the Commission is licensing PCS providers at different times and multiple PCS licensees may benefit from the relocation of a microwave system or even a single link, the first PCS licensee in the market potentially bears a disproportionate share of relocation costs. Subsequent PCS licensees to enter the market may therefore obtain a windfall. As a result of this potential "free rider" problem, the first PCS licensee in the market might not relocate a link or might delay its deployment of PCS if it believes that another PCS licensee will relocate the link first, thus paying for some or all of the relocation costs. In addition, unless cost-sharing is adopted, PCS licensees might not engage in relocation that is cost-effective if viewed from an industry-wide perspective. For example, a link that encumbers two PCS blocks might not be moved if the cost is greater than the benefit to any single licensee, even though the joint benefit received by two or more licensees exceeds the cost of relocating the link.

5. In 1994, PCIA proposed a cost-sharing plan to alleviate the free rider problem, which the Commission found to be attractive in theory but dismissed

as underdeveloped. On May 5, 1995, Pacific Bell ("PacBell") filed a Petition for Rulemaking. In its petition, PacBell proposed a detailed cost-sharing plan in which PCS licensees on all blocks, licensed and unlicensed, would share in the cost of relocating microwave stations. On May 16, 1995, the Commission requested comment on PacBell's proposal. Most parties that commented on PacBell's *Petition for Rulemaking* supported the cost-sharing concept, although the comments reflected some differences regarding the details of the proposal. On October 12, 1995, the Commission adopted a *Notice of Proposed Rule Making*, 60 FR 55529 (November 1, 1995) which sought comment on a modified version of the plan proposed by PacBell.

6. The Commission released and adopted, with this *First Report and Order*, a *Further Notice of Proposed Rule Making*, 61 FR 24470 (May 15, 1996).

## II. First Report and Order

7. In the *Cost-Sharing Notice*, the Commission proposed a number of changes and clarifications to the microwave relocation rules adopted in the *Emerging Technologies* docket. The Commission suggested that additional guidance with respect to certain aspects of its rules would facilitate negotiations, reduce disputes, and expedite deployment of PCS. As explained below, the Commission adopts many of the changes and clarifications the Commission proposed, along with some suggestions made by commenters. By adopting these rule changes and clarifications, as well as the cost-sharing plan discussed in Section B, *infra*, the Commission intends to expedite the clearing of the 2 GHz band and the introduction of PCS to the public, while protecting the rights of incumbents. The Commission seeks to promote an efficient and equitable relocation process, which minimizes transaction costs and maximizes benefits for all parties, including incumbents, PCS licensees, and the public.

### A. Microwave Relocation Rules

#### 1. Voluntary Negotiations

8. The Commission agrees with commenters who argue that the public interest would not be served by changing the rules regarding the voluntary period for the A and B blocks at this time. First, the A and B block licensees who are now negotiating with incumbents were on notice of the voluntary period when they bid for their licenses, and they presumably have factored the length of the period and the

potential cost of relocation into their bids. They have offered no persuasive justification to shorten the period now. Second, the Commission notes that many voluntary agreements have already been reached or are now being negotiated between A and B block licensees and incumbents. The Commission is concerned that altering the voluntary period could inadvertently delay the deployment of PCS, because negotiations are likely to be interrupted while parties reassess their bargaining positions. Nevertheless, the Commission agrees with PCS licensees that changing the negotiation period for blocks other than the A and B blocks may not raise the same concerns, because negotiations in these blocks have not commenced.

9. Whether or not the negotiation periods are changed, the Commission also agrees with PCS licensees that additional information about the value of an incumbent's system, the estimated amount of time it would take to relocate the incumbent, and the anticipated cost of relocation may help facilitate negotiations during the voluntary period, as the Commission suggested in the *Cost-Sharing Notice*. Therefore, the Commission will require that, if the parties have not reached an agreement within one year after the commencement of the voluntary period, the incumbent must allow the PCS licensee, if the PCS licensee so chooses, to gain access to the microwave facilities to be relocated so that an independent third party can examine the incumbent's 2 GHz system and prepare an estimate of the cost and the time needed to relocate the incumbent to comparable facilities. The PCS licensee must pay for any such cost estimate. Because the one-year anniversary of the commencement of the voluntary period for A and B block licensees has already passed, this requirement shall become effective for the A and B block on the effective date of the rules adopted in this proceeding. The Commission disagrees with incumbents that a cost estimate paid for by the PCS licensee changes the nature of the voluntary period, because participation in negotiations remains voluntary.

10. Finally, although the Commission is not altering the basic structure or length of the voluntary period for A and B block PCS licensees, the Commission emphasizes that its rules provide incentives for voluntary agreements. The Commission has stated in the past that PCS licensees may choose to offer incumbents premiums to relocate quickly. "Premiums" could include: replacing the analog facilities with

digital facilities, paying all of the incumbent's transactions costs, or relocating an entire system as opposed to just the interfering links. These incentives are available only to microwave incumbents who consent to relocation by negotiation. By contrast, PCS licensees are not obligated to pay for such premiums during an involuntary relocation, which is discussed in Section IV(A)(3), *infra*.

#### 2. Mandatory Negotiations

11. As the comments on this issue demonstrate, the question of whether parties are negotiating in good faith typically requires consideration of all the facts and circumstances underlying the negotiations, and thus is likely to depend on the specific facts in each case. The Commission is concerned that creating a presumption that a party is acting in good or bad faith, as proposed in the *Cost-Sharing Notice*, may slow down resolution of disputes by prompting parties to bring claims of bad faith to the Commission prematurely rather than focusing on resolving the underlying disputes through the negotiation process. For these reasons, the Commission declines to adopt its proposal creating a presumption that a party who declines an offer of comparable facilities is acting in bad faith. Instead, the Commission concludes that good faith should be evaluated on a case-by-case basis under basic principles of contract law. Nevertheless, the Commission agrees with those commenters who suggest that guidance with respect to the factors the Commission will consider if a dispute arises over good faith would be helpful.

12. First, the Commission believes that good faith requires each party to provide information to the other that is reasonably necessary to facilitate the relocation process. For example, upon request by a PCS licensee, the Commission expects incumbents to allow inspection of their facilities by the PCS licensee and to provide any other information that the PCS licensee needs in order to evaluate the cost of relocating the incumbent to comparable facilities. Second, when evaluating claims that a party has not negotiated in good faith, the Commission will consider, *inter alia*, the following factors: (1) whether the PCS licensee has made a *bona fide* offer to relocate the incumbent to comparable facilities; (2) if the microwave incumbent has demanded a premium, the type of premium requested (*e.g.*, whether the premium is directly related to relocation, such as system-wide relocations and analog-to-digital conversions, versus other types of

premiums) and whether the value of the premium as compared to the cost of providing comparable facilities is disproportionate (*i.e.*, whether there is a lack of proportion or relation between the two); (3) what steps the parties have taken to determine the actual cost of relocation to comparable facilities; and (4) whether either party has withheld information requested by the other party that is necessary to estimate relocation costs or to facilitate the relocation process.

13. To ensure that parties do not bring frivolous bad faith claims, the Commission will also require any party alleging a violation of the Commission's good faith requirement to provide an independent estimate of the relocation costs of the facilities in question. Independent estimates must include a specification for the comparable facility and a statement of the costs associated with providing that facility to the incumbent licensee. These cost estimates are similar to the cost estimates that the Commission requires if a dispute arises over comparable facilities during the involuntary relocation period. The Commission believes that requiring such estimates will assist them in determining whether the parties are negotiating in good faith. Finally, the Commission agrees with those commenters who argue that penalties for failure to negotiate in good faith should be imposed on a case-by-case basis. The Commission emphasizes, however, that they intend to use the full realm of enforcement mechanisms available to them in order to ensure that licensees bargain in good faith.

### 3. Involuntary Relocation

14. If no agreement is reached during either the voluntary or mandatory negotiation period, a PCS licensee may initiate involuntary relocation procedures. Under involuntary relocation, the incumbent is required to relocate, provided that the PCS licensee meets the conditions under the Commission's rules for making the incumbent whole, such as providing the incumbent with comparable facilities.

#### *a. Comparable Facilities*

15. The Commission concludes that the factors they have identified—communications throughput, system reliability, and operating costs—will be the three factors used to determine when a facility is comparable. As the Commission stated in the *Cost-Sharing Notice*, the Commission believes that providing guidance with respect to the term comparable facilities will facilitate negotiations and reduce disputes. The

record in this proceeding also supports adoption of the factors the Commission has identified. Each factor is discussed in more detail below.

16. *Communication Throughput.* The Commission defines communications throughput as the amount of information transferred within the system in a given amount of time. For analog systems the throughput is measured by the number of voice channels, and for digital systems it is measured in bits per second ("bps"). Therefore, if analog facilities are being replaced by analog facilities, the PCS licensee will be required to provide the incumbent with an equivalent number of 4 kHz voice channels. If an existing digital system is being replaced by digital facilities, the PCS licensee will be required to provide the incumbent with equivalent data loading bps in order for the system to be considered comparable. The Commission agrees with commenters that the more difficult issue will be determining equivalent throughput when analog equipment is being replaced with digital equipment, which can be like comparing "apples with oranges." If disputes arise, the Commission will determine on a case-by-case basis whether comparable throughput has been achieved. For guidance, the Commission plans to refer to other parts of its rules where analog-digital comparisons have been made, such as the minimum channel loading requirements for fixed point-to-point microwave systems in Section 21.710(d).

17. The Commission also concludes that, during involuntary relocation, PCS licensees will only be required to provide incumbents with enough throughput to satisfy their needs at the time of relocation, rather than to match the overall capacity of the system, as some microwave incumbents suggest. For example, the Commission will not require that a 2 GHz incumbent with 5 MHz of bandwidth be relocated to a 5 MHz bandwidth, 6 GHz location when its current needs only justify a 1.25 MHz bandwidth system. If a dispute arises, the Commission will determine what an incumbent's needs are by looking at actual system use rather than total capacity at the time of relocation. The Commission expressly adopted channelization plans for the 6 GHz band with bandwidth requirements ranging from 400 kHz to 30 MHz to increase the efficiency of use by point-to-point microwave operations. Although the Commission recognizes that this policy may affect an incumbent's ability to increase its capacity over time, the Commission agrees with PCS licensees that the public interest would not be

served if spectrum is automatically held in reserve for all incumbents with the expectation that some may require additional capacity in the future. The Commission's goal is to foster efficient use of the spectrum, which would be thwarted if all incumbents are relocated to systems with capacity that exceeds their current needs. Also, limiting spectrum to current needs serves the public interest, because the Commission believes that it will promote the development of spectrum-efficient technology capable of increasing capacity without increasing bandwidth.

18. *Reliability.* The Commission defines system reliability as the degree to which information is transferred accurately within the system. As stated in the *Cost-Sharing Notice*, the reliability of a system is a function of equipment failures (*e.g.*, transmitters, feed lines, antennas, receivers, battery back-up power, etc.), the availability of the frequency channel due to propagation characteristic (*e.g.*, frequency, terrain, atmospheric conditions, radio-frequency noise, etc.), and equipment sensitivity. The Commission defines comparable reliability as that equal to the overall reliability of the incumbent system, and the Commission will not require the system designer to build the radio link portion of the system to a higher reliability than that of the other components of the system. For example, if an incumbent system had a radio link reliability of 99.9999 percent, but an overall reliability of only 99.999 percent because of limited battery back-up power, the Commission requires that the new system have a radio link reliability of 99.999 percent to be considered comparable. For digital data systems this would be measured by the percent of time the bit error rate ("BER") exceeds a desired value, and for analog or digital voice transmissions this would be measured by the percent of time that audio signal quality met an established threshold. Under this approach, for a replacement digital system to be comparable, the data rate throughput must be equal to or greater than that of the incumbent system with an equal or greater reliability. If an analog voice system is replaced with a digital voice system the resulting frequency response, harmonic distortion, signal-to-noise ratio, and reliability would be the factors considered. The Commission declines to adopt AUE's request that the Commission include a "system age" component that takes into account how the age of a given system can affect system reliability, because the

Commission does not have enough information to determine how age will affect a given system. Moreover, the Commission believes that older equipment of high quality may be as reliable as newer equipment of low quality.

19. *Operating Costs.* The Commission defines operating costs as the cost to operate and maintain the microwave system. These costs fall into several categories. First, the incumbent must be compensated for any increased recurring costs associated with the replacement facilities (e.g., additional rental payments, increased utility fees). Although the Commission originally proposed that recurring costs should be limited to a ten-year license term, the Commission is persuaded by PCS licensees that a five-year time period—which is the length of a microwave license in the 1850–1990 MHz band—is a more appropriate time frame, because it strikes an appropriate balance between the burden placed on PCS licensees who must relocate many incumbents, and the burden placed on incumbents that are being forced to relocate. Furthermore, the Commission believes that the five-year time period is not unfair to incumbents because, by five years from now, many incumbents would have been forced to bear some of these costs themselves—such as increased rents—if they had not already been relocated by PCS licensees. Moreover, the Commission is also persuaded that a five-year time period provides incumbents with sufficient time for budget planning and resource allocation to meet such expenses once the five-year period expires. Finally, the Commission concludes that a PCS licensee is permitted but not required to satisfy its obligation by making a lump-sum payment based on present value using current interest rates, as suggested by some incumbents.

20. Second, increased maintenance costs must be taken into consideration when determining whether operating costs are comparable. As several commenters point out, maintenance costs associated with analog systems are frequently higher than the costs for equivalent digital systems, because manufacturers are producing mostly digital equipment and analog replacement parts can be difficult to find. The Commission declines to adopt API's suggestion that "serviceability"—which would require that access to those elements essential to restoration of service be equal to or greater than the original system—should be adopted as a fourth element, however, because the Commission believes that the ease of servicing the equipment will affect

repair costs, which will be factored into operating costs. Furthermore, the Commission agrees with incumbents that, in some instances, the operating costs of 6 GHz analog equipment might be so high that analog replacement facilities would not qualify as comparable. On the other hand, if an available analog replacement system would provide equivalent technical capability without increasing the incumbent's operating costs or sacrificing any of the other factors the Commission has identified, the Commission agrees with PCS licensees that such an analog system would be acceptable. In sum, the Commission's goal is to ensure that incumbents are no worse off than they would be if relocation were not required, not to guarantee incumbents superior systems at the expense of PCS licensees.

21. *Trade Offs.* The Commission also concludes that comparable replacement facilities may not be provided by trading off any of the system parameters discussed above. Thus, the Commission agrees with incumbents that PCS licensees should not be permitted to compromise on one aspect of comparability, such as system reliability, by compensating with another factor, such as increased throughput. Based on the record in this proceeding, the Commission believes that the factors the Commission has identified are central to the concept of comparability, and therefore the replacement system provided to an incumbent during an involuntary relocation must be at least equivalent to the incumbent's existing system with respect to system reliability, throughput, and operating costs. However, other aspects of the system (e.g., bandwidth) do not have to be equivalent to the incumbent's original 2 GHz system. As PCS licensees point out, it might be possible to achieve comparability with respect to the three main factors, even though all of the features on the replacement equipment are not identical to those of the original system. Other media, such as land lines, would also be acceptable, provided that comparability is achieved.

22. *Depreciation.* In the *Cost-Sharing Notice*, the Commission also sought comment on whether and how depreciation of equipment and facilities should be taken into account, and whether it would be appropriate for a PCS licensee to compensate an incumbent only for the depreciated value of the old equipment. Some PCS licensees contend that depreciation should be taken into account during the mandatory period as a means of encouraging incumbents to accept offers

during the voluntary period. The Commission is persuaded by incumbents, however, that compensation for the depreciated value of old equipment would not enable them to construct a comparable replacement system without imposing costs on the incumbent, which would be inconsistent with the Commission's relocation rules. The Commission therefore concludes that the depreciated value of old equipment should not be a factor when determining comparability.

#### *b. Relocating Individual Links*

23. The Commission affirms its decision in the 1994 *Memorandum Opinion and Order* that PCS licensees are obligated to pay to relocate incumbents to comparable facilities only with respect to the specific microwave links for which their systems pose an interference problem. Thus, the Commission clarifies that PCS licensees are not under an obligation to move an incumbent's entire system at once, unless all of the links in the incumbent's system would be subject to interference by the PCS licensee. Although system-wide relocations may be preferable and less disruptive to the incumbent, the Commission concludes that it would be inappropriate to increase a PCS licensee's monetary obligation, e.g., by requiring it to pay to relocate links that it never intended to move, after the licenses have already been auctioned. In fact, several commenters—particularly those bidding in the C block auction—have stated in their comments that they are intentionally designing their systems in such a way that existing links will not have to be relocated. Moreover, incumbents are not harmed by this policy because, as PCS licensees point out, many incumbents already operate networks that consist of both 2 GHz and 6 GHz links or a combination of digital and analog technology. Furthermore, the Commission's rules protect microwave operations by requiring PCS licensees to provide incumbents with a seamless transition from their old facilities to the replacement facilities. Thus, if providing a seamless transition requires it, PCS licensees must relocate additional links or pay for additional costs associated with integrating the new links into the old system, such as employing a different modulation technique to preserve the system's overall integrity. If problems arise, the PCS licensee is required under the Commission's rules to remedy the situation.

24. To ease the burden on incumbents, the Commission has adopted a cost-sharing plan to promote

the relocation of all links in a system at the same time. By enabling PCS licensees to collect reimbursement from subsequent licensees that benefit from the relocation, the Commission believes that its cost-sharing plan will promote a larger number of system-wide relocations.

#### c. Transaction Expenses

25. The Commission concludes that incumbents should be reimbursed only for legitimate and prudent transaction expenses that are directly attributable to an involuntary relocation, subject to a cap of two percent of the "hard" costs involved (e.g., equipment, new towers, site acquisition). Although the Commission proposed in the *Cost-Sharing Notice* that PCS licensees should not be required to reimburse incumbents for any "extraneous" expenses, such as fees for attorneys and consultants, the Commission is persuaded by commenters that some reimbursement for outside assistance is necessary, because not all incumbents have expertise in these fields within their organizations. The Commission concludes that PCS licensees are not required to pay incumbents for internal resources devoted to the relocation process, however, because such expenses are difficult to determine and would be too hard for a PCS licensee to verify. Moreover, the benefits incumbents receive as a result of relocation, such as superior equipment, are likely to outweigh any internal costs they incur.

26. To prevent abuses, PCS licensees will not be required to reimburse incumbents for transaction costs that exceed two percent of the hard costs associated with an involuntary relocation. Rather than adopt a cap on the dollar amount that can be spent on transaction expenses, the Commission believes that a percentage of the total hard costs, as suggested by Cox & Smith, is more appropriate. Therefore, if complicated and costly actions, such as land acquisition, are required to accomplish relocation, the permissible amount of reimbursement for transaction costs would be higher. The Commission also believes that a two-percent cap is reasonable and strikes a fair balance between the concerns of PCS licensees and microwave incumbents. The Commission derived two percent from CIPCO's suggested cap of \$5,000 per link, which is two-percent of \$250,000—the amount the Commission has determined to be the average cost of relocating a link. Furthermore, PCS licensees will not be required to pay for transaction costs incurred by incumbents during the

voluntary or mandatory negotiation periods once an involuntary relocation is initiated, nor will they be required to pay for fees that cannot be legitimately tied to the provision of comparable facilities, such as consultant fees for determining how much of a premium payment PCS licensees would be willing to pay. The Commission agrees with PCS licensees that they should not have to reimburse incumbents for such fees, because it would encourage incumbents to view the relocation process as a business opportunity. Furthermore, requiring PCS licensees to pay such fees does not serve the public interest, because added expenses are likely to be passed on to the public in the form of increased PCS subscriber fees.

#### d. Twelve-Month Trial Period

27. As a preliminary matter, the Commission clarifies that the twelve-month trial period is only automatic if an involuntary relocation occurs. Therefore, if the parties decide that a trial period should be established for relocations that occur during the voluntary and mandatory period, they must provide for such a period in the relocation contract.

28. Because our proposed clarifications to the twelve-month trial period received broad record support, the Commission adopts the following clarifications to Section 94.59(e) of our rules:

(1) The trial period will commence on the date that the incumbent begins full operation (as opposed to testing) on the replacement link; and

(2) An incumbent's right to a twelve-month trial period resides with the incumbent as a function of the Commission's relocation rules, regardless of whether the incumbent has previously surrendered its license. If, however, a microwave licensee has retained its 2 GHz authorization during the trial period, it is required to return the license to the Commission at the conclusion of that period.

In Commission's initial rule, 47 CFR §94.59(c), the Commission stated that they would convert the microwave incumbent to secondary status after the replacement system is built and the microwave incumbent has been provided with a reasonable amount of time to determine comparability. The Commission sees no reason, however, for the incumbent to retain its 2 GHz license once it has been relocated. The Commission declines to adopt the suggestion that the Commission's twelve-month trial period should be extended or begin again if a problem arises. The Commission concludes that

incumbents are adequately protected without such an extension because, by the end of the twelve-month period, the Commission's rules require that they be operating on facilities that are comparable. If at the end of the twelve months the PCS licensee has still failed to meet this requirement, it must relocate the incumbent back to its former or equivalent 2 GHz frequencies. Thus, the expiration of the twelve-month period does not leave the incumbent without further recourse.

29. As a related matter, the Commission clarifies that, even after the PCS licensee has initiated the involuntary relocation process, a mutually acceptable agreement will still be permissible. If the parties do sign an agreement specifying their own terms, the Commission will treat the agreement in the same manner as the Commission treats agreements that are consummated during the voluntary and mandatory periods, and the parties will be bound by contract rather than our rules. The Commission agrees with commenters that neither incumbents nor PCS licensees are harmed by such a policy, because neither party is obligated to enter into such an agreement. If the agreement falls through, however, the incumbent will be subject to involuntary relocation.

30. Finally, the Commission declines to reduce the trial period to one month as suggested by PCS licensees. The Commission agrees with incumbents that twelve months is an appropriate time period, because it gives the incumbent the opportunity to ensure that the facilities function properly during changes in climate and vegetation. The Commission also takes this opportunity to clarify that PCS licensees are not required to leave the incumbent's former 2 GHz spectrum vacant during the twelve-month trial period. The Commission agrees with PCIA that requiring PCS licensees to hold this spectrum in reserve would delay the deployment of PCS for at least one year, which does not serve the public interest. The Commission also clarifies that, if the microwave incumbent demonstrates that the new facilities are not comparable to the former facilities, the PCS licensee must remedy the defects or pay to relocate the microwave licensee to one of the following: its former or equivalent 2 GHz channels, another comparable frequency band, a land-line system, or any other facility that qualifies as comparable.

*e. Request for Clarification of Involuntary Relocation Procedures*

31. The Commission believes that AT&T Wireless, *et al.*, have raised legitimate issues regarding the procedures for implementing involuntary relocation at the conclusion of the mandatory negotiation period. The issues raised in their letter, however, were not included in the *Cost-Sharing Notice*, nor were they raised in any of the regularly filed comments or reply comments in this proceeding. Because of the relative lateness of the parties' *ex parte* filing and the lack of opportunity for other parties to comment, the Commission declines to address these issues at this time. Nevertheless, the Commission encourages the parties to the April 15 letter or any other interested parties to file a petition for rulemaking on the issues raised in the letter.

#### 4. Public Safety Certification

32. The Commission agrees with PCS licensees that certification is necessary to ensure that only those public safety incumbents meriting special status are allowed the advantages of extended negotiation periods. The Commission also agrees with incumbents, however, that self-certification is appropriate, because self-certification will not burden public agencies with time-consuming reporting requirements. The Commission declines to adopt the suggestion made by AT&T that all public safety incumbents should be required to apply to the Commission for certification, because such a requirement would be administratively burdensome for the Commission and could delay negotiations. Furthermore, the Commission believes that PacBell's concerns about biased public agencies are overstated, because the Commission does not believe public agencies will be inclined to falsify the certification.

33. The Commission concludes that, in order for a public safety licensee to qualify for extended negotiation periods under the Commission's rules, the department head responsible for system oversight must certify to the PCS licensee requesting relocation that:

(1) The agency is a licensee in the Police Radio, Fire Radio, Emergency Medical, Special Emergency Radio Services, or that it is a licensee of other Part 94 facilities licensed on a primary basis under the eligibility requirements of Part 90, Subparts B and C; and

(2) the majority of communications carried on the facilities at issue involve safety of life and property.

A public safety licensee must provide certification within 30 days of a request

from a PCS licensee or the PCS licensee may presume that special treatment is inapplicable to the incumbent. If an incumbent falsely certifies to a PCS licensee that it qualifies for the extended time periods, the incumbent will be in violation of the Commission's rules and subject to appropriate penalties. Such an incumbent would also immediately become subject to the non-public safety time periods.

#### 5. Dispute Resolution

34. Because relocations that occur pursuant to agreements arrived at during the voluntary and mandatory period are relocations pursuant to private contracts, the Commission anticipates that parties will pursue common law contract remedies if a dispute arises. Thus, if parties do not agree to use alternative dispute resolution techniques, the Commission expects that they will file suit in a court of competent jurisdiction.

35. To the extent that disputes arise over violation of the Commission's rules (e.g., the good faith requirement, involuntary relocation procedures), the Commission has stated that parties are encouraged to use ADR techniques. Commenters agree that resolution of such disputes entirely by the Commission's adjudication processes would be time consuming and costly to all parties. Therefore, the Commission continues to encourage parties to employ ADR techniques when disputes arise.

#### 6. Ten Year Sunset

36. As the Commission stated in the *Cost-Sharing Notice*, the Commission continues to believe that an emerging technology licensee's obligation to relocate 2 GHz microwave incumbents should not continue indefinitely; however, the Commission is also persuaded by incumbents that immediate conversion to secondary status in the year 2005 may not be necessary, especially with respect to rural links that would not interfere with any PCS systems. To strike a fair balance between these competing interests, the Commission concludes that 2 GHz microwave incumbents will retain primary status unless and until an emerging technology licensee requires use of the spectrum, but that the emerging technology licensee will not be obligated to pay relocation costs after the relocation rules sunset, *i.e.*, ten years after the voluntary period begins for the first emerging technology licensees in the service (which is April 4, 2005, for PCS licensees and unlicensed PCS). Once the relocation rules sunset, an emerging technology licensee may

require the incumbent to either cease operations or pay to relocate itself to alternate facilities, provided that the emerging technology licensee intends to turn on a system within interference range of the incumbent, as determined by TIA Bulletin 10-F or any standard successor thereto. Notification must be in writing, and the emerging technology licensee must provide the incumbent with no less than six months to vacate the spectrum. Emerging technology licensees may provide notice prior to the date that the relocation rules sunset, but may not turn on their systems until after that date. After the six-month notice period has expired, the incumbent will be required to turn its 2 GHz license back into the Commission, unless the parties have entered into an agreement which allows the incumbent to continue to operate on a mutually agreed upon basis. The Commission concludes that their decision promotes spectrum efficiency, because it allows microwave incumbents to continue to operate in the 2 GHz band until their spectrum is needed by an emerging technology licensee.

37. The Commission believes that a sunset date for the Commission's microwave relocation rules serves the public interest, because it provides certainty to the process and prevents the emerging technology licensee from being required to pay for relocation expenses indefinitely. Moreover, the Commission agrees with commenters that ten years provides incumbents with sufficient time (1) to negotiate a relocation agreement or (2) to plan for relocation themselves. In fact, well over ten years will have passed since the Commission first announced our intention to reallocate 2 GHz spectrum to foster the introduction of emerging technologies services in 1992. In other services, the Commission has provided incumbents with even less time to complete relocation. For example, private operational fixed microwave stations in the 12 GHz band received only five years to relocate their facilities before they became secondary to the Direct Broadcast Satellite ("DBS") Service.

38. The Commission also believes that adopting a sunset date is important, because it will provide 2 GHz microwave incumbents with an incentive to relocate to other bands when it comes time to change or replace their equipment. At the current time, the Commission's licensing records indicate that most 2 GHz microwave incumbents use analog equipment. APCO contends that operating 2 GHz analog microwave systems is becoming infeasible, because analog systems are



now outdated and replacement parts will soon be difficult, if not impossible, to find. APCO also states that most incumbents have long-term plans to replace their analog systems with digital systems once the useful life of current equipment has expired and/or adequate funding has been found. As BellSouth points out, by the time the sunset date arrives, much of the microwave equipment operating today at 2 GHz is likely to be either fully amortized or in need of replacement. The Commission believes that informing 2 GHz incumbents that they will have to cover their own relocation expenses after ten years will encourage incumbents to relocate to another band when they replace existing equipment. By contrast, if emerging technology licensees are required to pay to relocate incumbents regardless of when the relocation occurs, incumbents will have little incentive to make such a transition to an alternate band voluntarily. For similar reasons, the Commission rejects the argument by incumbents that PCS licensees should be required to make relocation offers prior to the sunset date to all incumbents located within their market area. Again, incumbents would have no incentive to change out their own systems voluntarily if they knew that PCS licensees would be required to cover the expenses for them at a later date. Furthermore, even if the Commission had not reallocated the spectrum, these incumbents would have had to plan ahead for repair costs, replacement equipment, and infrastructure improvement. Given that most incumbents will incur significant expenses in any event when they replace their analog system with digital equipment, the Commission believes that providing an incentive to incumbents to relocate voluntarily at the same time they purchase new equipment serves the public interest. In sum, the Commission believes that the benefits of imposing a sunset date outweigh the burdens, if any, that such a date may impose.

39. Finally, the Commission believes that six months is a reasonable amount of time for most incumbents to relocate their facilities, especially because they will have been on notice for ten years that they might be requested to move. Nevertheless, the Commission acknowledges that special circumstances might warrant an extension of the six-month period in some instances to enable the incumbent to complete relocation activities. If the incumbent is unable to move or cannot complete relocation in time, the Commission encourages the parties to

negotiate a mutually acceptable solution. In the event that the parties cannot agree on a schedule or an alternative arrangement, the Commission will entertain extension requests on a case-by-case basis. However, the Commission intends to grant such extensions only if the incumbent can demonstrate that: (1) it cannot relocate within the six-month period (e.g., because no alternative spectrum or other reasonable option is available), and (2) the public interest would be harmed if the incumbent is forced to terminate operations (e.g., if public safety communications services would be disrupted).

#### *B. Cost-Sharing Plan*

##### 1. Overview

40. The Commission adopts its proposed plan with a few modifications suggested by commenters. The Commission believes that cost-sharing serves the public interest because (1) it will distribute relocation costs more equitably among PCS licensees, and (2) it will promote the relocation of entire microwave systems at once, which will benefit microwave incumbents. The Commission also believes that cost-sharing will accelerate the relocation process for the PCS band as a whole, thus promoting more rapid deployment of service to the public. Furthermore, the Commission concludes that the benefits of cost-sharing outweigh the costs that may be incurred by licensees who become subject to reimbursement obligations. Under the plan, these licensees will be required to pay reimbursement obligations only when they have benefitted from the spectrum-clearing efforts of another party. Moreover, as discussed in greater detail below, the Commission is adopting limits on reimbursement to ensure that licensees subject to the plan do not bear a disproportionate cost. The Commission concludes that these provisions amply protect the interests of such licensees.

41. Under the Commission's cost-sharing plan, a PCS licensee obtains reimbursement rights for a particular link on the date that it signs a relocation agreement with the microwave incumbent operating on the link at issue. Within ten business days of the date the agreement is signed, the PCS licensee submits documentation of the agreement to a non-profit clearinghouse, which will be selected by the Wireless Telecommunications Bureau ("Bureau"). If the clearinghouse has not yet been selected, the PCS relocater will be responsible for submitting documentation of a relocation

agreement within ten business days of the date that the Bureau announces that the clearinghouse has been established and has begun operation.

42. Prior to commencing commercial operation, each PCS licensee is required to send a prior coordination notification ("PCN") to all existing users in the area. At the same time, each PCS licensee shall file a copy of the PCN with the clearinghouse. The clearinghouse will then apply an objective test to determine whether the proposed base station would have posed an interference problem to the relocated link. If the test shows that the proposed base station is close enough to have posed an interference problem, the clearinghouse will notify the subsequent licensee that it is required to reimburse the PCS relocater under the cost-sharing formula for a portion of the expenses the relocater incurred to move the link. UTAM will be required to reimburse PCS relocaters who relocate microwave links that were operating in the unlicensed PCS band.

43. The clearinghouse will determine the amount that the subsequent PCS licensee must pay the relocater through the use of a cost-sharing formula. The formula takes into consideration such factors as the actual amount paid to relocate the link and the number of PCS licensees that would have interfered with the link. All calculations will be done on a per-link basis. The reimbursement amount also decreases over time to reflect the fact that the initial PCS relocater has received the benefit of being first to market, and to ensure that the PCS relocater pays the largest amount, which the Commission believes will provide an incentive to the relocater to limit relocation expenses. As an additional protection for later-entrants, the Commission has imposed a cap of \$250,000 per link, with an additional \$150,000 if a new or modified tower is required, on the amount that a PCS relocater may recoup for the relocation of each individual microwave link. PCS relocaters are entitled to full reimbursement, up to the cap, for relocating non-interfering links fully outside their market area or licensed frequency band. Also, costs that are incurred prior to the selection of a clearinghouse will be reimbursable after a clearinghouse is established.

44. Once a PCS licensee receives written notification from the clearinghouse of its reimbursement obligation, it must pay the entire amount owed within thirty calendar days, with the exception of those small businesses that qualify for installment payments under the Commission's auction rules. UTAM will be required to



reimburse a PCS relocater once a county is cleared of enough microwave links to enable unlicensed PCS devices to operate. Because UTAM receives its funding in small increments over an extended period of time, UTAM will be permitted to satisfy its reimbursement obligation by making quarterly installment payments to the PCS relocater over a period of five years, at an interest rate of prime plus three percent.

45. The cost-sharing plan will sunset for all PCS licensees ten years after the date that voluntary negotiations commenced for A and B block licensees, on April 4, 2005. However, the sunset date will not eliminate the existing obligations of PCS licensees that are paying their portion of relocation costs on an installment basis. Those licensees must continue their payments until the obligation is satisfied. Finally, while the Commission concludes that the cost-sharing plan is in the public interest, the Commission is conditioning its adoption of these rules on approval of an entity or organization to administer the plan. Once an administrator is selected, the cost-sharing rules will take effect.

46. *Participation in Cost-Sharing Plan.* By this *Report and Order*, the Commission mandates that all PCS licensees benefitting from spectrum clearance by other PCS licensees must contribute to such relocation costs. As the Commission emphasized in the *Cost-Sharing Notice*, however, PCS licensees remain free to negotiate alternative cost-sharing terms. The Commission also agrees with commenters that allowing PCS licensees to enter into such private agreements serves the public interest, because it adds flexibility to the cost-sharing process and may enable such parties to save both time and the administrative expense of seeking reimbursement from a clearinghouse. The Commission therefore concludes that licensees are not required to participate in the Commission's cost-sharing plan if they enter into alternative cost-sharing agreements. The Commission also agrees with commenters that all parties to a separate agreement will still be liable under the cost-sharing plan to other PCS licensees that incur relocation expenses. Finally, the Commission concludes that parties to a private cost-sharing agreement may also seek reimbursement through the clearinghouse from PCS licensees that are not parties to the agreement.

## 2. Dispute Resolution Under the Cost-Sharing Plan

47. The Commission agrees with those commenters who argue that disputes arising out of the cost-sharing plan, such as disputes over the amount of reimbursement required, should be brought to the clearinghouse first for resolution. At the time the dispute is brought to the clearinghouse, the parties will be required to submit appropriate documentation, e.g., an independent appraisal of the equipment expenses at issue, to support their position. To the extent that disputes cannot be resolved by the clearinghouse, the Commission encourages parties to use expedited ADR procedures, such as binding arbitration, mediation, or other ADR techniques. At this time, the Commission does not designate a specific penalty for failure to comply with cost-sharing requirements; however, the Commission emphasizes that they intend to use the full realm of enforcement mechanisms available to them in order to ensure that reimbursement obligations are satisfied.

## 3. Administration of the Cost-Sharing Plan

48. The Commission agrees with those commenters who suggest that the clearinghouse administrator should be selected through an open process. The Commission also believes it is essential for the plan to be administered by industry to the fullest extent possible. Therefore, before the Commission implements the plan, the Commission will seek specific proposals from parties who wish to act as administrator and will request public comment on any such proposals.

49. The Commission delegates to the Wireless Bureau the authority to select one or more entities to create and administer a neutral, not-for-profit clearinghouse. Selection shall be based on criteria established by the Bureau. The Bureau shall publicly announce the criteria and solicit proposals from qualified parties. Once such proposals have been received, and an opportunity has elapsed for public comment on them, the Bureau shall make its selection. When the Bureau selects an administrator, it shall announce the effective date of the cost-sharing rules.

### C. Licensing Issues

50. As of the effective date of the new rules, the Commission will grant pending and newly filed applications for all major modifications and all extensions to existing 2 GHz microwave systems on a secondary basis. The Commission will grant primary status

for the following limited number of technical changes: decreases in power, minor changes in antenna height, minor location changes (up to two seconds), any data correction which does not involve a change in the location of an existing facility, reductions in authorized bandwidths, minor changes in structure heights, changes in ground elevation (but preserving centerline height), and changes in equipment. All other modifications will be permitted on a secondary basis, unless (1) the incumbent affirmatively justifies primary status, and (2) the incumbent establishes that the modification would not add to the relocation costs of PCS licensees. The Commission declines to adopt the suggestion made by PCS licensees that no modifications should be allowed even on a secondary basis, because some incumbents might not need to relocate for several years, and they should be permitted to make modifications to their systems during that time period. The Commission also disagrees with incumbents that the Commission's licensing policy should be expanded, because the Commission believes that limiting primary site grants is necessary to protect the interests of PCS licensees. In sum, the Commission believes that granting secondary site authorizations serves the public interest, because it balances existing licensees' need to expand their systems with the goal of minimizing the number of microwave links that PCS licensees must relocate.

51. Furthermore, the Commission clarifies that secondary operations may not cause interference to operations authorized on a primary basis, and they are not protected from interference from primary operations. Thus, an incumbent operating under a secondary authorization must cease operations if it poses an interference problem to a PCS licensee. However, prior to commencing operations, PCS licensees are obligated to provide all incumbents that are operating within interference range, regardless of whether an incumbent is operating under a primary or a secondary site authorization, with thirty days notice that they will be commencing operations in the vicinity. Finally, PCS licensees are under no obligation to pay to relocate secondary links that exist within their market area and frequency block.

### D. Application to Other Emerging Technology Licensees

52. The Commission agrees with AT&T that the cost-sharing plan and rule clarifications adopted in this proceeding should apply to all emerging technology services, including those

services in the 2110–2150 and 2160–2200 GHz band that have not yet been licensed, because the microwave relocation rules already apply to all emerging technology services. For the same reasons that these changes will facilitate the deployment of PCS, the Commission believes these changes will also facilitate the deployment of other emerging technology services. For example, these changes and clarifications will provide additional guidance and help to accelerate negotiations between the parties. However, as new services develop, the Commission may review its relocation rules and make modifications to these rules where appropriate. In addition, while the Commission concludes that cost-sharing should apply to all emerging technology services, the Commission does not adopt specific cost-sharing rules for new services at this time, but will develop such rules in future proceedings.

### III. Conclusion

53. The Commission believes that the rules adopted in this *Report and Order* will promote the public policy goals set forth by Congress. The cost-sharing formula adopted herein will facilitate the rapid relocation of microwave facilities operating in the 2 GHz band, and will allow PCS licensees to offer service to the public in an expeditious manner.

### IV. Procedural Matters

#### A. Regulatory Flexibility Act

As required by Section 603 of the Regulatory Flexibility Act, an Initial Regulatory Flexibility Analysis (IRFA) was incorporated in the *Notice of Proposed Rule Making* in WT Docket No. 95–157, RM–8643. The Commission has prepared a Regulatory Flexibility Analysis of the expected impact on small entities of the proposals suggested in this document. Written comments were requested. The Commission's final analysis is as follows:

*Need for and purpose of the action:* This rulemaking proceeding has implemented Congress' goal of encouraging emerging technologies and bringing innovative commercial wireless services to the public in an efficient manner. The cost-sharing plan will promote the efficient relocation of microwave licensees by encouraging PCS licensees to relocate entire microwave systems rather than individual microwave links. A cost-sharing plan is necessary to enhance the speed of relocation and provide an incentive to PCS licensees to negotiate system-wide relocation agreements with

microwave incumbents. This action will result in faster deployment of PCS and delivery of service to the public. The Commission has also clarified some terminology regarding certain aspects of the Commission's rules for microwave relocation contained in the Commission's *Emerging Technologies* proceeding, Docket No. 92–9.

*Issues raised in response to the IRFA:* The American Public Power Association ("APPA") states that conversion of 2 GHz microwave systems to secondary status in the year 2005 would have a particularly severe impact on the limited budgets of small, non-profit public utility systems.

*Significant alternatives considered and rejected:* Although the Commission has decided not to convert microwave incumbents to secondary status automatically as the Commission proposed in the *Cost-Sharing Notice*, microwave incumbents will be required to pay for their own relocation costs after the sunset date. The Commission has considered the impact of the ten year sunset date, and the Commission has determined that the benefits of imposing a sunset date outweigh the burdens such a date may impose on these incumbents. For further discussion, see Section IV(A)(6), *supra*.

#### B. Paperwork Reduction Act

This *First Report and Order* contains either a proposed or modified information collection. The Commission, as part of its continuing effort to reduce paperwork burdens, invites the general public and the Office of Management and Budget (OMB) to comment on the information collections contained in this *First Report and Order*, as required by the Paperwork Reduction Act of 1995, Public Law 104–13. Comments should address: (a) whether the proposed collection of information is necessary for the proper performance of the functions of the Commission, including whether the information shall have practical utility; (b) the accuracy of the Commission's burden estimates; (c) ways to enhance the quality, utility and clarity of the information collected; and (d) ways to minimize the burden of the collection of information on the respondents, including the use of automated collection techniques or other forms of information technology.

*Further Information.* For additional information concerning the information collections contained in this Report and Order, contact Dorothy Conway at (202) 418–0217, or via the Internet at [dconway@fcc.gov](mailto:dconway@fcc.gov).

*Supplementary Information:*

*Title:* Amendment of the Commission's Rules Regarding a Plan for Sharing the Costs of Microwave Relocation, First Report and Order.

*Type of Review:* Revision to existing collection.

*Respondents:* Personal Communications Service licensees that relocate existing microwave operators, subsequent Personal Communications Service applicants potentially benefitted by such relocation, and incumbent microwave operators.

*Number of Respondents:* Approximately 2,000.

*Estimated Time Per Response:* One hour to compose, type and mail the information to the requesting party.

*Total Annual Burden:* Approximately 2,000 hours.

*Estimated Costs Per Respondent:* Assuming that respondent uses one attorney at \$200/hour to compose, type and mail the information to the requesting party, respondents' costs are estimated at approximately \$200 per one-time response.

*Needs and Uses.* The Commission recently adopted a *First Report and Order* regarding a plan for sharing the costs of relocating microwave facilities currently operating in the 1850 to 1990 MHz (2 GHz) band, which has been allocated for use by broadband Personal Communications Services (PCS).

*Amendment of the Commission's Rules Regarding a Plan for Sharing the Costs of Microwave Relocation, First Report and Order*, adopted April 25, 1996. The *First Report and Order* establishes a mechanism whereby PCS licensees that incur costs to relocate microwave links would receive reimbursement for a portion of those costs from other PCS licensees that also benefit from the resulting clearance of the spectrum.

The *First Report and Order* concludes, *inter alia*, that in order for a public safety licensee to qualify for extended negotiation periods under the Commission's Rules, the department head responsible for system oversight must certify to the PCS licensee requesting relocation that:

(1) the agency is a licensee in the Police Radio, Fire Radio, Emergency Medical, Special Emergency Radio Services, or that it is a licensee of other Part 94 facilities licensed on a primary basis under the eligibility requirements of Part 90, Subparts B and C; and

(2) the majority of communications carried on the facilities at issue involve safety of life and property.

A public safety licensee must provide certification within 30 days of a request from a PCS licensee, or the PCS licensee may presume that special treatment is inapplicable to the incumbent.

In addition, the *First Report and Order* concludes that good faith negotiation between parties involved in microwave relocation requires each party to provide information to the other that is reasonably necessary to facilitate the relocation process. For example, upon request by a PCS licensee, the Commission expects incumbents to provide any information that the PCS licensee needs in order to evaluate the cost of relocating the incumbent to comparable facilities.

The legal authority for this proposed information collection includes 47 U.S.C. Sections 154(i), 303(c), 303(f), 303(g), 303(r) and 332. The information collection would not affect any FCC Forms. The proposed collection would increase minimally the burden on public safety licensees seeking to qualify for an extended negotiation period by requiring such a licensee to self-certify to the PCS licensee requesting relocation that it is indeed a public safety licensee, and by requiring that licensees share information in good faith.

#### C. *Ex Parte* Rules—Non-Restricted Proceeding

This is a non-restricted notice and comment rulemaking proceeding. *Ex parte* presentations are permitted except during the Sunshine Agenda period, provided they are disclosed as provided in Commission rules.

#### D. Authority

Authority for issuance of this *Report and Order* is contained in the Communications Act, Sections 4(i), 7, 303(c), 303(f), 303(g), 303(r), and 332, 47 U.S.C. §§ 154(i), 157, 303(c), 303(f), 303(g), 303(r), 332, as amended.

#### E. Ordering Clauses

Accordingly, *it is ordered* that Section 15.307 is amended as set forth below and will become effective August 12, 1996.

*It is further ordered* that Section 22.602 is amended as set forth below and will become effective August 12, 1996.

*It is further ordered* that Sections 24.5, 24.237, 24.239, 24.241, 24.243, 24.245, 24.247, 24.249, 24.251, 24.251 and 24.253 are amended as set forth below.

*It is further ordered* that the cost-sharing plan is conditioned on approval by the Wireless Telecommunications Bureau of an entity (or entities) to administer the plan, as described in Section IV(B)(3), *supra*.

*It is further ordered* that Part 24 rule changes will become applicable on the date that the Wireless Telecommunications Bureau selects a

clearinghouse to administer the cost-sharing plan. The Commission will issue a public announcement after the selection has been made.

*It is further ordered* that Sections 101.3, 101.67, 101.69, 101.71, 101.73, 101.75, 101.77, 101.79, 101.81 and 101.147, the new Part 101 (effective August 1, 1996) of the Commission's rules are amended as set forth below and will become effective August 1, 1996.

*It is further ordered* that rules requiring Paperwork Reduction Act approval shall become effective upon approval by the Office of Management and Budget pursuant to the Paperwork Reduction Act of 1995, Public Law No. 104-13;

*It is further ordered that*, as of the effective dates of the rules listed herein, the Commission will only grant primary status to applications for minor modifications that would not add to the relocation costs of PCS licensees, as described in Section IV(C) *supra*.

*It is further ordered that*, as of the effective dates of the rules listed herein, the Commission will grant applications for major modifications and extensions to existing 2 GHz microwave systems only on a secondary basis, as described in Section IV(C) *supra*.

*It is further ordered* that the Regulatory Flexibility Analysis, as required by Section 604 of the Regulatory Flexibility Act, and as set forth in Section VII(A) is *adopted*.

*It is further ordered* that the Secretary shall send a copy of this *First Report and Order* to the Chief Counsel for Advocacy of the Small Business Administration.

#### List of Subjects

##### 47 CFR Part 15

Radio.

##### 47 CFR Part 22

Radio.

##### 47 CFR Part 24

Personal communications services.

##### 47 CFR Part 101

Fixed microwave services.

Federal Communications Commission.

William F. Caton,  
*Acting Secretary.*

#### Rule Changes

Parts 15, 22, 24 and 101 of Chapter I of Title 47 of the Code of Federal Regulations are amended as follows:

## PART 15—RADIO FREQUENCY DEVICES

1. The authority citation for Part 15 is revised to read as follows:

Authority: 47 U.S.C. 154, 302, 303, 304, 307 and 544A.

2. Section 15.307 is amended by revising paragraphs (a), (f) and (g) to read as follows:

#### § 15.307 Coordination with fixed microwave service.

(a) UTAM, Inc. is designated to coordinate and manage the transition of the 1910–1930 MHz band from the Private Operational-Fixed Microwave Service (OFS) operating under Part 101 of this chapter to unlicensed PCS operations,

\* \* \* \* \*

(f) At such time as the Commission deems that the need for coordination between unlicensed PCS operations and existing Part 101 Private Operational-Fixed Microwave Services ceases to exist, the disabling mechanism required by paragraph (e) of this section will no longer be required.

(g) Operations under the provisions of this subpart are required to protect systems in the Private Operational-Fixed Microwave Service operating within the 1850–1990 MHz band until the dates and conditions specified in §§ 101.69 through 101.73 of this chapter for termination of primary status. Interference protection is not required for Part 101 stations in this band licensed on a secondary basis.

\* \* \* \* \*

## PART 22—PUBLIC MOBILE SERVICES

3. The authority citation for Part 22 is revised to read as follows:

Authority: 47 U.S.C. 154, 303, unless otherwise noted.

4. Section 22.602 is revised to read as follows:

#### § 22.602 Transition of the 2110–2130 and 2160–2180 MHz channels to emerging technologies.

The microwave channels listed in § 22.591 have been allocated for use by emerging technologies (ET) services. No new systems will be authorized under this part. The rules in this section provide for a transition period during which existing Paging and Radiotelephone Service (PARS) licensees using these channels may relocate operations to other media or to other fixed channels, including those in other microwave bands. For PARS licensees relocating operations to other microwave bands, authorization must be obtained under Part 101 of this chapter.

(a) Licensees proposing to implement ET services may negotiate with PARS licensees authorized to use these channels, for the purpose of agreeing to terms under which the PARS licensees would—

(1) Relocate their operations to other fixed microwave bands or other media, or alternatively,

(2) Accept a sharing arrangement with the ET licensee that may result in an otherwise impermissible level of interference to the PARS operations.

(b) PARS operations on these channels will continue to be co-primary with other users of this spectrum until two years after the FCC commences acceptance of applications for ET services, and until one year after an ET licensee initiates negotiations for relocation of the fixed microwave licensee's operations.

(c) *Voluntary Negotiations.* During the two year voluntary negotiation period, negotiations are strictly voluntary and are not defined by any parameters. However, if the parties have not reached an agreement within one year after the commencement of the voluntary period, the PARS licensee must allow the ET licensee (if it so chooses) to gain access to the existing facilities to be relocated so that an independent third party can examine the PARS licensee's 2 GHz system and prepare an estimate of the cost and the time needed to relocate the PARS licensee to comparable facilities. The ET licensee must pay for any such estimate.

(d) *Mandatory Negotiations.* If a relocation agreement is not reached during the two year voluntary period, the ET licensee may initiate a mandatory negotiation period. This mandatory period is triggered at the option of the ET licensee, but ET licensees may not invoke their right to mandatory negotiation until the voluntary negotiation period has expired. Once mandatory negotiations have begun, a PARS licensee may not refuse to negotiate and all parties are required to negotiate in good faith. Good faith requires each party to provide information to the other that is reasonably necessary to facilitate the relocation process. In evaluating claims that a party has not negotiated in good faith, the FCC will consider, *inter alia*, the following factors:

(1) Whether the ET licensee has made a *bona fide* offer to relocate the PARS licensee to comparable facilities in accordance with Section 101.75(b) of this chapter;

(2) If the PARS licensee has demanded a premium, the type of premium requested (*e.g.*, whether the premium is directly related to

relocation, such as system-wide relocations and analog-to-digital conversions, versus other types of premiums), and whether the value of the premium as compared to the cost of providing comparable facilities is disproportionate (*i.e.*, whether there is a lack of proportion or relation between the two);

(3) What steps the parties have taken to determine the actual cost of relocation to comparable facilities;

(4) Whether either party has withheld information requested by the other party that is necessary to estimate relocation costs or to facilitate the relocation process. Any party alleging a violation of our good faith requirement must attach an independent estimate of the relocation costs in question to any documentation filed with the Commission in support of its claim. An independent cost estimate must include a specification for the comparable facility and a statement of the costs associated with providing that facility to the incumbent licensee.

(e) *Involuntary period.* After the periods specified in paragraph (b) of this section have expired, ET licensees may initiate involuntary relocation procedures under the Commission's rules. ET licensees are obligated to pay to relocate only the specific microwave links to which their systems pose an interference problem. Under involuntary relocation, a PARS licensee is required to relocate, provided that:

(1) The ET applicant, provider, licensee or representative guarantees payment of relocation costs, including all engineering, equipment, site and FCC fees, as well as any legitimate and prudent transaction expenses incurred by the PARS licensee that are directly attributable to an involuntary relocation, subject to a cap of two percent of the hard costs involved. Hard costs are defined as the actual costs associated with providing a replacement system, such as equipment and engineering expenses. ET licensees are not required to pay PARS licensees for internal resources devoted to the relocation process. ET licensees are not required to pay for transaction costs incurred by PARS licensees during the voluntary or mandatory periods once the involuntary period is initiated or for fees that cannot be legitimately tied to the provision of comparable facilities;

(2) The ET applicant, provider, licensee or representative completes all activities necessary for implementing the replacement facilities, including engineering and cost analysis of the relocation procedure and, if radio facilities are involved, identifying and obtaining, on the incumbents behalf,

new channels and frequency coordination; and,

(3) The ET applicant, provider, licensee or representative builds the replacement system and tests it for comparability with the existing 2 GHz system.

(f) *Comparable Facilities.* The replacement system provided to an incumbent during an involuntary relocation must be at least equivalent to the existing PARS system with respect to the following three factors:

(1) *Throughput.* Communications throughput is the amount of information transferred within a system in a given amount of time. If analog facilities are being replaced with analog, the ET licensee is required to provide the PARS licensee with an equivalent number of 4 kHz voice channels. If digital facilities are being replaced with digital, the ET licensee must provide the PARS licensee with equivalent data loading bits per second (bps). ET licensees must provide PARS licensees with enough throughput to satisfy the PARS licensee's system use at the time of relocation, not match the total capacity of the PARS system.

(2) *Reliability.* System reliability is the degree to which information is transferred accurately within a system. ET licensees must provide PARS licensees with reliability equal to the overall reliability of their system. For digital data systems, reliability is measured by the percent of time the bit error rate (BER) exceeds a desired value, and for analog or digital voice transmissions, it is measured by the percent of time that audio signal quality meets an established threshold. If an analog voice system is replaced with a digital voice system, only the resulting frequency response, harmonic distortion, signal-to-noise ratio and its reliability will be considered in determining comparable reliability.

(3) *Operating Costs.* Operating costs are the cost to operate and maintain the PARS system. ET licensees must compensate PARS licensees for any increased recurring costs associated with the replacement facilities (*e.g.* additional rental payments, increased utility fees) for five years after relocation. ET licensees may satisfy this obligation by making a lump-sum payment based on present value using current interest rates. Additionally, the maintenance costs to the PARS licensee must be equivalent to the 2 GHz system in order for the replacement system to be considered comparable.

(g) The PARS licensee is not required to relocate until the alternative facilities are available to it for a reasonable time to make adjustments, determine

comparability, and ensure a seamless handoff.

(h) *The Commission's Twelve-Month Trial Period.* If, within one year after the relocation to new facilities, the PARS licensee demonstrates that the new facilities are not comparable to the former facilities, the ET applicant, provider, licensee or representative must remedy the defects or pay to relocate the PARS licensee to one of the following: its former or equivalent 2 GHz channels, another comparable frequency band, a land-line system, or any other facility that satisfies the requirements specified in paragraph (f) of this section. This trial period commences on the date that the PARS licensee begins full operation of the replacement link. If the PARS licensee has retained its 2 GHz authorization during the trial period, it must return the license to the Commission at the end of the twelve months.

(i) After April 25, 1996, all major modifications and extensions to existing PARS systems operating on channels in the 2110–2130 and 2160–2180 MHz bands will be authorized on a secondary basis to future ET operations. All other modifications will render the modified PARS license secondary to future ET operations unless the incumbent affirmatively justifies primary status and the incumbent PARS licensee establishes that the modification would not add to the relocation costs of ET licensees. Incumbent PARS licensees will maintain primary status for the following technical changes:

- (1) Decreases in power;
- (2) Minor changes (increases or decreases) in antenna height;
- (3) Minor location changes (up to two seconds);
- (4) Any data correction which does not involve a change in the location of an existing facility;
- (5) Reductions in authorized bandwidth;
- (6) Minor changes (increases or decreases) in structure height;
- (7) Changes (increases or decreases) in ground elevation that do not affect centerline height;
- (8) Minor equipment changes.

(j) *Sunset.* PARS licensees will maintain primary status in the 2110–2130 and 2160–2180 MHz bands unless and until an ET licensee requires use of the spectrum. ET licensees are not required to pay relocation costs after the relocation rules sunset (*i.e.* ten years after the voluntary period begins for the first ET licensees in the service). Once the relocation rules sunset, an ET licensee may require the incumbent to

cease operations, provided that the ET licensee intends to turn on a system within interference range of the incumbent, as determined by TIA Bulletin 10-F or any standard successor. ET licensee notification to the affected PARS licensee must be in writing and must provide the incumbent with no less than six months to vacate the spectrum. After the six-month notice period has expired, the PARS licensee must turn its license back into the Commission, unless the parties have entered into an agreement which allows the PARS licensee to continue to operate on a mutually agreed upon basis. If the parties cannot agree on a schedule or an alternative arrangement, requests for extension will be accepted and reviewed on a case-by-case basis. The Commission will grant such extensions only if the incumbent can demonstrate that:

- (1) It cannot relocate within the six-month period (*e.g.*, because no alternative spectrum or other reasonable option is available), and;
- (2) The public interest would be harmed if the incumbent is forced to terminate operations (*e.g.*, if public safety communications services would be disrupted).

**PART 24—PERSONAL COMMUNICATIONS SERVICES**

5. The authority citation for Part 24 is revised to read as follows:

Authority: 47 U.S.C. 154, 301, 302, 303, 309 and 332.

6. Section 24.5 is amended by adding the definitions for “PCS Relocator” and “UTAM” in alphabetical order to read as follows:

**§ 24.5 Definitions.**

\* \* \* \* \*

*PCS Relocator.* A PCS entity that pays to relocate a fixed microwave link from its existing 2 GHz facility to other media or other fixed channels.

*UTAM.* The Unlicensed PCS Ad Hoc Committee for 2 GHz Microwave Transition and Management, which coordinates relocation in the 1910–1930 MHz band.

\* \* \* \* \*

7. Section 24.237 is amended by revising paragraph (c) to read as follows:

**§ 24.237 Interference protection.**

\* \* \* \* \*

(c) In all other respects, coordination procedures are to follow the requirements of § 101.103(d) of this chapter to the extent that these

requirements are not inconsistent with those specified in this part.

\* \* \* \* \*

8. Subpart E is amended by adding a new heading following Section 24.238 to read as follows:

**Policies Governing Microwave Relocation From the 1850–1990 MHz Band**

9. A new Section 24.239 is added to Subpart E to read as follows:

**§ 24.239 Cost-sharing requirements for Broadband PCS.**

Frequencies in the 1850–1990 MHz band listed in § 101.147(c) of this chapter have been allocated for use by PCS. In accordance with procedures specified in §§ 101.69 through 101.81 of this chapter, PCS entities (both licensed and unlicensed) are required to relocate the existing Fixed Microwave Services (FMS) licensees in these bands if interference to the existing FMS operations would occur. All PCS entities who benefit from spectrum clearance by other PCS entities must contribute to such relocation costs. PCS entities may satisfy this requirement by entering into private cost-sharing agreements or agreeing to terms other than those specified in § 24.243. However, PCS entities are required to reimburse other PCS entities that incur relocation costs and are not parties to the alternative agreement. In addition, parties to a private cost-sharing agreement may seek reimbursement through the clearinghouse (as discussed in § 24.241) from PCS entities that are not parties to the agreement. The cost-sharing plan is in effect during all phases of microwave relocation specified in § 101.69 of this chapter.

10. A new Section 24.241 is added to Subpart E to read as follows:

**§ 24.241 Administration of the Cost-Sharing Plan.**

The Wireless Telecommunications Bureau, under delegated authority, will select an entity to operate as a neutral, not-for-profit clearinghouse. This clearinghouse will administer the cost-sharing plan by, *inter alia*, maintaining all of the cost and payment records related to the relocation of each link and determining the cost-sharing obligation of subsequent PCS entities. The cost-sharing rules will not take effect until an administrator is selected.

11. A new Section 24.243 is added to Subpart E to read as follows:

**§ 24.243 The Cost-Sharing Formula.**

A PCS relocater who relocates an interfering microwave link, i.e., one that is in all or part of its market area and in all or part of its frequency band, is entitled to pro rata reimbursement based on the following formula:

$$R_N = \frac{C}{N} \times \frac{[120 - (T_m)]}{120}$$

(a) *R<sub>N</sub>* equals the amount of reimbursement.

(b) *C* equals the actual cost of relocating the link. Actual relocation costs include, but are not limited to, such items as: radio terminal equipment (TX and/or RX—antenna, necessary feed lines, MUX/Modems); towers and/or modifications; back-up power equipment; monitoring or control equipment; engineering costs (design/path survey); installation; systems testing; FCC filing costs; site acquisition and civil works; zoning costs; training; disposal of old equipment; test equipment (vendor required); spare equipment; project management; prior coordination notification under § 101.103(d) of this chapter; required antenna upgrades for interference control; power plant upgrade (if required); electrical grounding systems; Heating Ventilation and Air Conditioning (HVAC) (if required); alternate transport equipment; and leased facilities. *C* also includes incumbent transaction expenses that are directly attributable to the relocation, subject to a cap of two percent of the “hard” costs involved. *C* may not exceed \$250,000 per link, with an additional \$150,000 permitted if a new or modified tower is required.

(c) *N* equals the number of PCS entities that would have interfered with the link. For the PCS relocater, *N* = 1. For the next PCS entity that would have interfered with the link, *N*=2, and so on.

(d) *T<sub>M</sub>* equals the number of months that have elapsed between the month the PCS relocater obtains reimbursement rights and the month that the clearinghouse notifies a later-entrant of its reimbursement obligation. A PCS relocater obtains reimbursement rights on the date that it signs a relocation agreement with a microwave incumbent.

12. A new Section 24.245 is added to Subpart E to read as follows:

**§ 24.245 Reimbursement under the Cost-Sharing Plan.**

(a) *Registration of Reimbursement Rights.* To obtain reimbursement, a PCS relocater must submit documentation of the relocation agreement to the clearinghouse within ten business days of the date a relocation agreement is signed with an incumbent. If the clearinghouse has not yet been selected, the PCS relocater will be responsible for submitting documentation of the relocation agreement within ten business days of the date that the Wireless Telecommunications Bureau issues a public notice announcing that the clearinghouse has been established and has begun operation.

(b) *Documentation of Expenses.* Once relocation occurs, the PCS relocater must submit documentation itemizing the amount spent for items listed in § 24.243(b). The PCS relocater must identify the particular link associated with appropriate expenses (i.e., costs may not be averaged over numerous links). If a PCS relocater pays a microwave incumbent a monetary sum to relocate its own facilities, the PCS relocater must estimate the costs associated with relocating the incumbent by itemizing the anticipated cost for items listed in § 24.243(b). If the sum paid to the incumbent cannot be accounted for, the remaining amount is not eligible for reimbursement. A PCS relocater may submit receipts or other

documentation to the clearinghouse for all relocation expenses incurred since April 5, 1995.

(c) *Full Reimbursement.* A PCS relocater who relocates a microwave link that is either fully outside its market area or its licensed frequency band may seek full reimbursement through the clearinghouse of compensable costs, up to the reimbursement cap as defined in § 24.243(b). Such reimbursement will not be subject to depreciation under the cost-sharing formula.

13. A new Section 24.247 is added to Subpart E to read as follows:

**§ 24.247 Triggering a Reimbursement Obligation.**

(a) *Licensed PCS.* The clearinghouse will apply the following test to determine if a PCS entity preparing to initiate operations must pay a PCS relocater in accordance with the formula detailed in § 24.243:

(1) All or part of the relocated microwave link was initially co-channel with the licensed PCS band(s) of the subsequent PCS entity;

(2) A PCS relocater has paid the relocation costs of the microwave incumbent; and

(3) The subsequent PCS entity is preparing to turn on a fixed base station at commercial power and the fixed base station is located within a rectangle (Proximity Threshold) described as follows:

(i) The length of the rectangle shall be *x* where *x* is a line extending through both nodes of the microwave link to a distance of 48 kilometers (30 miles) beyond each node. The width of the rectangle shall be *y* where *y* is a line perpendicular to *x* and extending for a distance of 24 kilometers (15 miles) on both sides of *x*. Thus, the rectangle is represented as follows:

BILLING CODE 6712-01-P

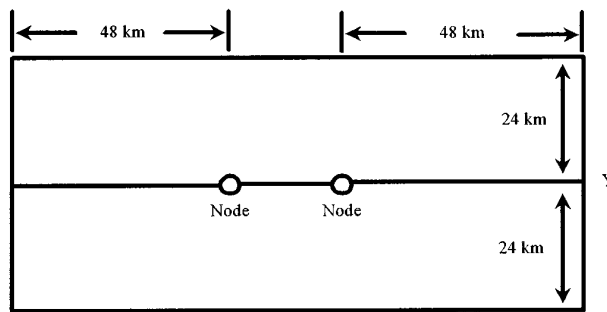

X

(ii) If the application of the Proximity Threshold test indicates that a reimbursement obligation exists, the clearinghouse will calculate the reimbursement amount in accordance with the cost-sharing formula and notify the subsequent PCS entity of the total amount of its reimbursement obligation.

(b) *Unlicensed PCS.* UTAM's reimbursement obligation is triggered either:

(1) When a county is cleared of microwave links in the unlicensed allocation, and UTAM invokes a Zone 1 power cap as a result of third party relocation activities; or

(2) A county is cleared of microwave links in the unlicensed allocation and UTAM reclassifies a Zone 2 county to Zone 1 status.

14. A new Section 24.249 is added to Subpart E to read as follows:

**§ 24.249 Payment Issues.**

(a) *Timing.* On the day that a PCS entity files its prior coordination notice (PCN) in accordance with § 101.103(d) of this chapter, it must file a copy of the PCN with the clearinghouse. The clearinghouse will determine if any reimbursement obligation exists and notify the PCS entity in writing of its repayment obligation, if any. When the PCS entity receives a written copy of such obligation, it must pay directly to the PCS relocater the amount owed within thirty days, with the exception of those businesses that qualify for installment payments. A business that qualifies for an installment payment plan must make its first installment payment within thirty days of notice from the clearinghouse. UTAM's first payment will be due thirty days after its reimbursement obligation is triggered as described in § 24.247(b).

(b) *Eligibility for Installment Payments.* PCS licensees that are allowed to pay for their licenses in installments under our designated entity rules will have identical payment options available to them with respect to payments under the cost-sharing plan. The specific terms of the installment payment mechanism, including the treatment of principal and interest, are the same as those applicable to the licensee's installment auction payments. If, for any reason, the entity eligible for installment payments is no longer eligible for such installment payments on its license, that entity is no longer eligible for installment payments under the cost-sharing plan. UTAM may make quarterly payments over a five-year period with an interest rate of prime plus 2.5 percent. UTAM may also negotiate separate repayment arrangements with other parties.

15. A new Section 24.251 is added to Subpart E to read as follows:

**§ 24.251 Dispute Resolution Under the Cost-Sharing Plan.**

Disputes arising out of the cost-sharing plan, such as disputes over the amount of reimbursement required, must be brought, in the first instance, to the clearinghouse for resolution. To the extent that disputes cannot be resolved by the clearinghouse, parties are encouraged to use expedited ADR procedures, such as binding arbitration, mediation, or other ADR techniques.

16. A new Section 24.253 is added to Subpart E to read as follows:

**§ 24.253 Termination of Cost-Sharing Obligations.**

The cost-sharing plan will sunset for all PCS entities on April 4, 2005, which is ten years after the date that voluntary negotiations commenced for A and B block PCS entities. Those PCS entities that are paying their portion of relocation costs on an installment basis must continue the payments until the obligation is satisfied.

**PART 101—FIXED MICROWAVE SERVICES**

17. The authority citation for Part 101 is revised to read as follows:

Authority: 47 U.S.C. 154, 303.

18. Section 101.3 is amended by adding the definition for "Secondary Operations" in alphabetical order to read as follows:

**§ 101.3 Definitions.**

\* \* \* \* \*

*Secondary Operations.* Radio communications which may not cause interference to operations authorized on a primary basis and which are not protected from interference from these primary operations.

\* \* \* \* \*

19. Subpart B is amended by adding a new heading following Section 101.67 to read as follows:

**Policies Governing Microwave Relocation From the 1850–1990 and 2110–2200 MHz Bands**

20. Section 101.69 is revised to read as follows:

**§ 101.69 Transition of the 1850–1990 and 2110–2200 MHz bands from the Fixed Microwave Services to Personal Communications Services and emerging technologies.**

Fixed Microwave Services (FMS) frequencies in the 1850–1990 and 2110–2200 MHz bands listed in §§ 101.147 (c), (d) and (e) have been allocated for use

by emerging technology (ET) services, including Personal Communications Services (PCS). The rules in this section provide for a transition period during which ET licensees may relocate existing FMS licensees using these frequencies to other media or other fixed channels, including those in other microwave bands.

(a) ET licensees may negotiate with FMS licensees authorized to use frequencies in the 1850–1990 and 2110–2200 MHz bands, for the purpose of agreeing to terms under which the FMS licensees would—

(1) Relocate their operations to other fixed microwave bands or other media; or alternatively

(2) Accept a sharing arrangement with the ET licensee that may result in an otherwise impermissible level of interference to the FMS operations.

(b) FMS operations in the 1850–1990 and 2110–2200 MHz bands, with the exception of public safety facilities defined in § 101.77, will continue to be co-primary with other users of this spectrum until two years after the FCC commences acceptance of applications for ET services (voluntary negotiation period), and until one year after an ET licensee initiates negotiations for relocation of the fixed microwave licensee's operations (mandatory negotiation period). In the 1910–1930 MHz band allocated for unlicensed PCS, FMS operations will continue to be co-primary until one year after UTAM, Inc. initiates negotiations for relocation of the fixed microwave licensee's operations. Public safety facilities defined in § 101.77 will continue to be co-primary in these bands until three years after the Commission commences acceptance of applications for an emerging technology service (voluntary negotiation period), and until two years after an emerging technology service licensee or an emerging technology unlicensed equipment supplier or representative initiates negotiations for relocation of the fixed microwave licensee's operations (mandatory negotiation period). If no agreement is reached during either the voluntary or mandatory negotiation periods, an ET licensee may initiate involuntary relocation procedures. Under involuntary relocation, the incumbent is required to relocate, provided that the ET licensee meets the conditions of § 101.75.

21. A new Section 101.71 is added to Subpart B to read as follows:



**§ 101.71 Voluntary Negotiations.**

During the two or three year voluntary negotiation period, negotiations are strictly voluntary and are not defined by any parameters. However, if the parties have not reached an agreement within one year after the commencement of the voluntary period, the FMS licensee must allow the ET licensee (if it so chooses) to gain access to the existing facilities to be relocated so that an independent third party can examine the FMS licensee's 2 GHz system and prepare an estimate of the cost and the time needed to relocate the FMS licensee to comparable facilities. The ET licensee must pay for any such estimate.

22. A new Section 101.73 is added to Subpart B to read as follows:

**§ 101.73 Mandatory Negotiations.**

(a) If a relocation agreement is not reached during the two or three year voluntary period, the ET licensee may initiate a mandatory negotiation period. This mandatory period is triggered at the option of the ET licensee, but ET licensees may not invoke their right to mandatory negotiation until the voluntary negotiation period has expired.

(b) Once mandatory negotiations have begun, an FMS licensee may not refuse to negotiate and all parties are required to negotiate in good faith. Good faith requires each party to provide information to the other that is reasonably necessary to facilitate the relocation process. In evaluating claims that a party has not negotiated in good faith, the FCC will consider, *inter alia*, the following factors:

(1) Whether the ET licensee has made a *bona fide* offer to relocate the FMS licensee to comparable facilities in accordance with Section 101.75(b);

(2) If the FMS licensee has demanded a premium, the type of premium requested (*e.g.*, whether the premium is directly related to relocation, such as system-wide relocations and analog-to-digital conversions, versus other types of premiums), and whether the value of the premium as compared to the cost of providing comparable facilities is disproportionate (*i.e.*, whether there is a lack of proportion or relation between the two);

(3) What steps the parties have taken to determine the actual cost of relocation to comparable facilities;

(4) Whether either party has withheld information requested by the other party that is necessary to estimate relocation costs or to facilitate the relocation process.

(c) Any party alleging a violation of our good faith requirement must attach an independent estimate of the

relocation costs in question to any documentation filed with the Commission in support of its claim. An independent cost estimate must include a specification for the comparable facility and a statement of the costs associated with providing that facility to the incumbent licensee.

23. A new Section 101.75 is added to Subpart B to read as follows:

**§ 101.75 Involuntary Relocation Procedures.**

(a) If no agreement is reached during either the voluntary or mandatory negotiation period, an ET licensee may initiate involuntary relocation procedures under the Commission's rules. ET licensees are obligated to pay to relocate only the specific microwave links to which their systems pose an interference problem. Under involuntary relocation, the FMS licensee is required to relocate, provided that the ET licensee:

(1) Guarantees payment of relocation costs, including all engineering, equipment, site and FCC fees, as well as any legitimate and prudent transaction expenses incurred by the FMS licensee that are directly attributable to an involuntary relocation, subject to a cap of two percent of the hard costs involved. Hard costs are defined as the actual costs associated with providing a replacement system, such as equipment and engineering expenses. ET licensees are not required to pay FMS licensees for internal resources devoted to the relocation process. ET licensees are not required to pay for transaction costs incurred by FMS licensees during the voluntary or mandatory periods once the involuntary period is initiated, or for fees that cannot be legitimately tied to the provision of comparable facilities;

(2) Completes all activities necessary for implementing the replacement facilities, including engineering and cost analysis of the relocation procedure and, if radio facilities are used, identifying and obtaining, on the incumbents' behalf, new microwave frequencies and frequency coordination; and

(3) Builds the replacement system and tests it for comparability with the existing 2 GHz system.

(b) *Comparable Facilities.* The replacement system provided to an incumbent during an involuntary relocation must be at least equivalent to the existing FMS system with respect to the following three factors:

(1) *Throughput.* Communications throughput is the amount of information transferred within a system in a given amount of time. If analog facilities are being replaced with analog, the ET

licensee is required to provide the FMS licensee with an equivalent number of 4 kHz voice channels. If digital facilities are being replaced with digital, the ET licensee must provide the FMS licensee with equivalent data loading bits per second (bps). ET licensees must provide FMS licensees with enough throughput to satisfy the FMS licensee's system use at the time of relocation, not match the total capacity of the FMS system.

(2) *Reliability.* System reliability is the degree to which information is transferred accurately within a system. ET licensees must provide FMS licensees with reliability equal to the overall reliability of their system. For digital data systems, reliability is measured by the percent of time the bit error rate (BER) exceeds a desired value, and for analog or digital voice transmissions, it is measured by the percent of time that audio signal quality meets an established threshold. If an analog voice system is replaced with a digital voice system, only the resulting frequency response, harmonic distortion, signal-to-noise ratio and its reliability will be considered in determining comparable reliability.

(3) *Operating Costs.* Operating costs are the cost to operate and maintain the FMS system. ET licensees must compensate FMS licensees for any increased recurring costs associated with the replacement facilities (*e.g.*, additional rental payments, increased utility fees) for five years after relocation. ET licensees may satisfy this obligation by making a lump-sum payment based on present value using current interest rates. Additionally, the maintenance costs to the FMS licensee must be equivalent to the 2 GHz system in order for the replacement system to be considered comparable.

(c) The FMS licensee is not required to relocate until the alternative facilities are available to it for a reasonable time to make adjustments, determine comparability, and ensure a seamless handoff.

(d) *Twelve-Month Trial Period.* If, within one year after the relocation to new facilities, the FMS licensee demonstrates that the new facilities are not comparable to the former facilities, the ET licensee must remedy the defects or pay to relocate the microwave licensee to one of the following: its former or equivalent 2 GHz channels, another comparable frequency band, a land-line system, or any other facility that satisfies the requirements specified in paragraph (b) of this section. This trial period commences on the date that the FMS licensee begins full operation of the replacement link. If the FMS licensee has retained its 2 GHz

authorization during the trial period, it must return the license to the Commission at the end of the twelve months.

24. A new Section 101.77 is added to Subpart B to read as follows:

**§ 101.77 Public Safety Licensees in the 1850–1990 and 2110–2200 MHz bands.**

(a) Public safety facilities are subject to the three-year voluntary and two-year mandatory negotiation period. In order for public safety licensees to qualify for extended negotiation periods, the department head responsible for system oversight must certify to the ET licensee requesting relocation that:

(1) The agency is a licensee in the Police Radio, Fire Radio, Emergency Medical, Special Emergency Radio Services, or that it is a licensee of other Part 101 facilities licensed on a primary basis under the eligibility requirements of Part 90, Subparts B and C of this chapter; and

(2) The majority of communications carried on the facilities at issue involve safety of life and property.

(b) A public safety licensee must provide certification within thirty (30) days of a request from a ET licensee, or the ET licensee may presume that special treatment is inapplicable. If a public safety licensee falsely certifies to an ET licensee that it qualifies for the extended time periods, this licensee will be in violation of the Commission's rules and will subject to appropriate penalties, as well as immediately subject to the non-public safety time periods.

25. A new Section 101.79 is added to Subpart B to read as follows:

**§ 101.79 Sunset provisions for licensees in the 1850–1990 and 2110–2200 MHz bands.**

(a) FMS licensees will maintain primary status in the 1850–1990 and 2110–2200 MHz bands unless and until an ET licensee requires use of the spectrum. ET licensees are not required to pay relocation costs after the relocation rules sunset (*i.e.* ten years after the voluntary period begins for the first ET licensees in the service). Once the relocation rules sunset, an ET licensee may require the incumbent to cease operations, provided that the ET licensee intends to turn on a system within interference range of the incumbent, as determined by TIA Bulletin 10-F or any standard successor. ET licensee notification to the affected FMS licensee must be in writing and must provide the incumbent with no less than six months to vacate the spectrum. After the six-month notice period has expired, the FMS licensee must turn its license back into the Commission, unless the parties have

entered into an agreement which allows the FMS licensee to continue to operate on a mutually agreed upon basis.

(b) If the parties cannot agree on a schedule or an alternative arrangement, requests for extension will be accepted and reviewed on a case-by-case basis. The Commission will grant such extensions only if the incumbent can demonstrate that:

(1) It cannot relocate within the six-month period (*e.g.*, because no alternative spectrum or other reasonable option is available), and;

(2) The public interest would be harmed if the incumbent is forced to terminate operations (*e.g.*, if public safety communications services would be disrupted).

26. A new Section 101.81 is added to Subpart B to read as follows:

**§ 101.81 Future licensing in the 1850–1990 and 2110–2200 MHz bands.**

After April 25, 1996, all major modifications and extensions to existing FMS systems in the 1850–1990 and 2110–2200 MHz bands will be authorized on a secondary basis to ET systems. All other modifications will render the modified FMS license secondary to ET operations, unless the incumbent affirmatively justifies primary status and the incumbent FMS licensee establishes that the modification would not add to the relocation costs of ET licensees. Incumbent FMS licensees will maintain primary status for the following technical changes:

(a) Decreases in power;  
 (b) Minor changes (increases or decreases) in antenna height;  
 (c) Minor location changes (up to two seconds);

(d) Any data correction which does not involve a change in the location of an existing facility;

(e) Reductions in authorized bandwidth;

(f) Minor changes (increases or decreases) in structure height;

(g) Changes (increases or decreases) in ground elevation that do not affect centerline height;

(h) Minor equipment changes.

27. Section 101.147 is amended by adding references to note 20 in the entries for frequency ranges 1,850–1,990, 2,130–2,150, 2,150–2,160 and 2,180–2,200 MHz and revising note 20 to read as follows:

**§ 101.147 Frequency assignments.**

(a)	*	*	*	*	*
1,850–1,990 MHz (20)	*	*	*	*	*
2,130–2,150 MHz (20) (22)	*	*	*	*	*
2,150–2,160 MHz (20) (22)	*	*	*	*	*
2,180–2,200 MHz (20), (22)	*	*	*	*	*

Notes

\* \* \* \* \*

(20) New facilities in these bands will be licensed only on a secondary basis. Facilities licensed or applied for before January 16, 1992, are permitted to make modifications and minor extensions in accordance with § 101.77 and still retain primary status.

\* \* \* \* \*

(22) Frequencies in these bands are for the exclusive use of Private Operational Fixed Point-to-Point Microwave Service (Part 101).

[FR Doc. 96–14138 Filed 6–11–96; 8:45 am]

BILLING CODE 6712–01–P

**DEPARTMENT OF COMMERCE**

**National Oceanic and Atmospheric Administration**

**50 CFR Part 301**

[Docket No. 960111003–6068–03; I.D. 060496A]

**Pacific Halibut Fisheries; 1996 Halibut Landing Report No. 2**

**AGENCY:** National Marine Fisheries Service (NMFS), National Oceanic and Atmospheric Administration (NOAA), Commerce.

**ACTION:** In season action.

**SUMMARY:** The Assistant Administrator for Fisheries, NOAA, on behalf of the International Pacific Halibut Commission (IPHC), publishes these inseason actions pursuant to IPHC regulations approved by the U.S. Government to govern the Pacific halibut fishery. This action is intended to enhance the conservation of the Pacific halibut stock.

**EFFECTIVE DATES:** Oregon sport halibut season closure: 11:59 p.m. May 25, 1996 until May 26, 1996; Southwest Washington coast sport halibut fishery closure: 11:59 p.m., May 26, 1996 until May 27, 1996.

**FOR FURTHER INFORMATION CONTACT:** Steven Pennoyer, 907-586-7221; William W. Stelle, Jr., 206-526-6140; or Donald McCaughran, 206-634-1838.

**SUPPLEMENTARY INFORMATION:** The IPHC, under the Convention between the United States of America and Canada for the Preservation of the Halibut Fishery of the Northern Pacific Ocean and Bering Sea (signed at Ottawa, Ontario, on March 2, 1953), as amended by a Protocol Amending the Convention (signed at Washington, DC, on March 29, 1979), has issued this inseason action pursuant to IPHC regulations governing the Pacific halibut fishery.