

# Rules and Regulations

Federal Register

Vol. 60, No. 167

Tuesday, August 29, 1995

This section of the FEDERAL REGISTER contains regulatory documents having general applicability and legal effect, most of which are keyed to and codified in the Code of Federal Regulations, which is published under 50 titles pursuant to 44 U.S.C. 1510.

The Code of Federal Regulations is sold by the Superintendent of Documents. Prices of new books are listed in the first FEDERAL REGISTER issue of each week.

## DEPARTMENT OF AGRICULTURE

### Rural Utilities Service

#### 7 CFR Part 1755

#### RUS Performance Specification for Line Concentrators

**AGENCY:** Rural Utilities Service, USDA.

**ACTION:** Final rule.

**SUMMARY:** The Rural Utilities Service formerly the Rural Electrification Administration (RUS) hereby amends its regulation on RUS Telecommunications Standards and Specifications for Material, Equipment and Construction by codifying the RUS bulletin concerning RUS Performance Specification for Line Concentrators, RUS form 397g. This specification has been incorporated by reference and will be rescinded after the effective date of the final rule. The specification updates the end product performance requirements brought about through technology advancements since this specification was last issued on July 29, 1985.

**DATES:** *Effective date.* This regulation is effective on September 28, 1995.

*Incorporation by reference.* Incorporation by reference of publications listed in this final rule is approved by the Director of the Federal Register as of September 28, 1995.

**FOR FURTHER INFORMATION CONTACT:** Mr. John J. Schell, Chief, Central Office Equipment Branch, Telecommunications Standards Division, U.S. Department of Agriculture, Rural Utilities Service, room 2838-S, AG Box 1598, Washington, DC 20250-1500. Telephone: 202-720-0671.

#### SUPPLEMENTARY INFORMATION:

#### Executive Order 12866

This rule has been determined to be not significant for purposes of Executive

Order 12866 and therefore has not been reviewed by OMB.

#### Executive Order 12778

This rule has been reviewed under Executive Order 12778, Civil Justice Reform. This rule:

(1) Will not preempt any state or local laws, regulations, or policies, unless they present an irreconcilable conflict with this rule;

(2) Will not have any retroactive effect; and

(3) Will not require administrative proceedings before any parties may file suit challenging the provisions of this rule.

#### Regulatory Flexibility Act Certification

RUS has determined that this rule will not have a significant economic impact on a substantial number of small entities, as defined by the Regulatory Flexibility Act (5 U.S.C. 601 et seq.) the RUS programs provide and finance grants and loans to RUS borrowers at interest rates and terms that are more favorable than those generally available from the private sector. RUS borrowers, as a result of obtaining Federal financing, receive economic benefits which ultimately offset any direct economic costs associated with complying with RUS regulations and requirements.

#### Information Collection and Recordkeeping Requirements

In compliance with the Office of Management and Budget (OMB) regulations (5 CFR Part 1320) which implements the Paperwork Reduction Act of 1980 (44 U.S.C. 3501 et seq.) and section 3504 of that Act, information collection and recordkeeping requirements contained in this rule have been approved by OMB under control number 0572-0059. Comments concerning these requirements should be directed to the Office of Information and Regulatory Affairs of OMB, Attention: Desk Officer for USDA, Room 10102, NEOB, Washington, DC 20503.

#### National Environmental Policy Act Certification

The Administrator has determined that this rule will not significantly affect the quality of the human environment as defined by the National Environmental Policy Act of 1969 (42 U.S.C. 4321 et seq.). Therefore, this action does not require an

environmental impact statement or assessment.

#### Catalog of Federal Domestic Assistance

The program described by this rule is listed in the Catalog of Federal Domestic Assistance Programs under number 10.851, Rural Telephone Loans and Loan Guarantees. This catalog is available on a subscription basis from the Superintendent of Documents, the United States Government Printing Office, Washington, DC 20402.

#### Executive Order 12372

This rule is excluded from the scope of Executive Order 12372, Intergovernmental Consultation. A Notice of Final Rule entitled Department Programs and Activities Excluded from Executive Order 12372 (50 FR 47034) exempts RUS and RTB loans and loan guarantees, and RTB bank loans, to governmental and nongovernmental entities from coverage under this Order.

#### Background

RUS makes loans and loan guarantees to telephone system to provide and improve telecommunications service in rural areas, as authorized by the Rural Electrification Act of 1936, as amended, 7 U.S.C. 901 et seq., (RE Act). RUS maintains a system of construction standards and specifications for materials and equipment. In accordance with the RUS loan contract, these standards and specifications apply to facilities constructed by RUS telephone borrowers.

Presently, RUS Bulletin 345-185, RUS Performance Specification for Line Concentrators RUS Form 397g, dated July 29, 1985, is incorporated by reference at 7 CFR 1755.97. Because of the many improvements in technology since the specification was last issued, RUS believes that by updating and codifying the revised specification, borrowers will be provided with an opportunity to improve and increase subscriber services through enhanced system designs brought about through the technological advancements in an economical and efficient manner.

#### General Comments

Public comments regarding the proposed rule (59 FR 19661, April 25, 1994) were received from AT&T and Hastad Engineering Company. These

comments were taken into consideration in preparing the final rule.

1. Comment. One commenter stated that the first sentence in paragraph (a)(iii) should be modified to read “\* \* \* without loss of individual identity by either physical or electronic means.”

Response. The intent of this requirement is to ensure that the identities of the lines connected to the remote line concentrator terminal are known at the central office. RUS feels this paragraph is a clear statement of this requirement.

2. Comment. One commenter stated that “at a minimum” should be added following “The concentrator system shall communicate with the standard T1 transmission format” in paragraph (b)(2).

Response. RUS agrees and this change has been made.

3. Comment. One commenter stated in the phrase “0.5 percent per month of all equipped cards in all system terminals after 6 months” in paragraph (c)(1) “system” should be changed to “systems.”

Response. In this context, the word “system” refers to the line concentrator system. The reliability requirement is meant to be applicable to each concentrator system individually.

4. Comment. One commenter stated that RUS should consider specifying a sine wave output for ringing generators in paragraph (f)(3)(ii).

Response. A sine wave output is one of the requirements for the acceptance of ringing generators by RUS. RUS does not feel that it is necessary to reiterate this requirement in the line concentrator specification.

5. Comment. One commenter stated that consideration should be given to providing an upper limit for loop current in paragraph (h)(2).

Response. The minimum current requirement ensures proper operation of the subscriber’s station equipment. The maximum current is largely dependent upon the design of the line concentrator’s line circuit. This specification is intended to be an operational rather than a design specification and RUS does not feel that a maximum current requirement is necessary in that light.

6. Comment. One commenter stated that the impedance of 900 ohms in paragraph (h)(3) is for D66 loaded cables, not non-loaded cable pairs.

Response. From a hybrid balance standpoint, 900 ohms in series with a 2.16 microfarad capacitor is not a very good match for either loaded or non-loaded loops. For this reason most switching equipment uses hybrid

termination networks more closely matching the characteristic impedances of the loops. However, as a compromise the 900 ohm termination was used in determining transmission requirements stated in paragraph (h)(3).

7. Comment. One commenter stated the requirement for a central office repeater and a DS1 bit stream may be a roadblock to the technical innovation. The STMP requirements for high bit rate services may not be supported by the low bit rate in paragraph (h)(20)(iv)(A).

Response. RUS agrees and has removed the repeater requirement and made the DS1 rate a minimum.

8. Comment. One commenter suggested two additions in paragraph (j)(1)(iii)(A): (1) Require testing of equipment with 100 Hz impedances beyond the 50 ohm maximum RUS has proposed, to a new maximum of 100 ohms, and (2) reduce the current surge test peak to 100 A from the required 500 A but require 25 plus and minus surges instead of the plus and minus five surges that RUS proposed.

Response. RUS evaluated the proposal by estimating the relative overall power that would be dissipated by the 100 Hz paths under the RUS proposal and the commenter’s proposal.

Because this proposal requires additional testing of 100 Hz impedance paths beyond the 50 ohms and because the proposer’s method of testing for overall and single surge power dissipation is less demanding on paths less than 5 and 10 ohms and more demanding for impedance paths greater than 5 and 10 ohms, respectively, RUS prefers to retain the requirement as RUS proposed it.

9. Comment. One commenter proposed in paragraph (j)(1)(iii)(B) that for 100 ohm, 60 Hz, impedance paths, using a 600 volt power supply and 86 ohm current limiting resistors (rather than the required 700 volt power supply and 100 ohm current limiting resistors) would result in approximately the same amount of current flow.

Response. Although not stated, RUS assumes that the commenter is suggesting the requirement be changed to allow the different power supply voltage and current limiting resistors. In evaluating the circuit testing differences, RUS calculated that the commenter’s proposal would result in 4.2 amps of current while the RUS proposal would cause 4.7 amps. Thus, the commenter’s proposal results in a 0.5 amp less current. Although 0.5 amp is not a major reduction (5 percent relative to the 10 amp maximum specified in the RUS proposal), it nevertheless is a 5-percent reduction.

The commenter’s suggested power supply voltage is also 100 volts lower than the RUS specified supply and it will not provide the same voltage stress that is contained in the RUS proposal.

RUS believes the Sixty Hertz Current Carrying test as proposed by RUS is necessary to properly test the system.

10. Comment. One commenter proposed in paragraphs (j)(1)(iii) (D) and (E) that the Voltage Impulse Test be modified to allow use of another waveshape (both peak and rise and fall times) and that for both the Voltage Impulse Test and the Arrester Response Delay Test that RUS allow results obtained by other organizations as part of their compliance testing to be acceptable for RUS compliance.

Response. RUS always attempts to accept test results conducted for other purposes as supporting data for RUS requirements when the data presented is equivalent or more stringent than RUS requirements.

All five tests are required to be conducted in a specific sequence and as quickly as possible; the endeavor is to inflict all stresses, one after another, in a very short time period for the total testing.

Testing conducted for other organizations, most likely, will not satisfy the concerns intended for the RUS electrical protection tests. In addition to not using the RUS specified waveshapes, tests by other organizations usually do not involve all the individual tests in the sequence required nor are they completed at the same time in the quick time frame required by RUS; results of various types of testing often may not be for tests conducted on the exact same test samples. In a number of cases, certain tests by other organizations are expected to destroy the product to be certain there is no fire or shock hazard. Although RUS is certainly interested in knowing of such hazards, the purpose of the RUS electrical protection testing is to see whether the line concentrator can withstand the specified surges and operate without any difficulty following the testing. Since test samples are destroyed by these other types of tests, such product evaluations cannot be made.

Because the test results suggested by the commenter are usually completed piecemeal and do not provide the overall rigorous test withstand concerns that RUS seeks, RUS cannot accept this suggestion to allow alternative waveshapes and prefers to retain the waveshape proposed in the proposed rule.

11. Comment. One commenter stated that RUS should provide a standard

requirement for 120/240 volts AC in paragraphs (q)(2)(vii) and (l)(2)(iii).

Response. RUS agrees and has made this change in paragraphs (q)(2)(vii) and (l)(2)(iii).

12. Comment. One commenter stated that battery heaters as specified in (l)(3)(iv) should not be a required item as determined by the bidder, but should be available as an option for the purchaser to accept or reject.

Response. RUS agrees and has changed this paragraph to read "when specified by the owner."

13. Comment. One commenter stated that since line concentrators are often installed by the purchaser, the bidder cannot provide job drawings as required in paragraph (p)(2)(iv). The commenter also stated that a minimum of three sets of drawings should be supplied for each central office involved rather than for each concentrator.

Response. RUS has added an additional requirement in (p)(2)(v) when installation is to be done by the bidder. This requirement states that a complete set of drawings shall be provided, such as floor plans, AC power access and grounding parameters. RUS has also stated that three sets of drawings are required per central office rather than per concentrator.

14. Comment. One commenter stated that an appropriate secondary arrester should be provided in the remote terminal cabinet.

Response. Paragraph (q)(2)(vii) requires that a secondary arrester be provided.

15. Comment. One commenter stated the specification should include a requirement for a remote cabinet ground lug, either on the cabinet's outside or mounted in the interior.

Response. Paragraph (q)(2)(ix) has been changed to include ground lugs.

#### List of Subjects in 7 CFR Part 1755

Incorporation by reference, Loan programs—communications, Reporting and recordkeeping requirements, Rural areas, Telephone.

For the reasons set out in the preamble, RUS amends chapter XVII of title 7 of the Code of Federal Regulations as set forth below.

#### PART 1755—TELECOMMUNICATIONS STANDARDS AND SPECIFICATIONS FOR MATERIALS, EQUIPMENT AND CONSTRUCTION

1. The authority citation for part 1755 is revised to read as follows:

**Authority:** 7 U.S.C. 901 *et seq.*, 1921 *et seq.*, 6941 *et seq.*

#### § 1755.97 [Amended]

2. Section 1755.97 is amended by removing the entry RUS Bulletin 345-185 from the table.

3. Section 1755.397 is revised to read as follows:

#### § 1755.397 RUS performance specification for line concentrators.

(a) *General.* (1) This section covers general requirements for a line concentrator (LC) system. This system shall operate in accordance with the manufacturer's specifications. Reliability shall be of prime importance in the design, manufacture and installation of the equipment. The equipment shall automatically provide for:

(i) Terminating subscriber lines at a location remote from the serving central office;

(ii) Concentrating the subscriber lines over a few transmission and supervisory paths to the serving central office; and

(iii) Terminating the lines at the central office without loss of individual identity. A subscriber connected to a line concentrator shall be capable of having essentially the same services as a subscriber connected directly to the central office equipment (COE). Intra-unit calling among subscribers connected to the concentrator may be provided, but is not required.

(2) Industry standards, or portions thereof, referred to in this paragraph (a) are incorporated by reference by RUS. This incorporation by reference was approved by the Director of the Federal Register in accordance with 5 U.S.C. 552 (a) and 1 CFR part 51. Copies of these standards are available for inspection during normal business hours at RUS, room 2838, U.S. Department of Agriculture, Washington, DC 20250 or at the Office of the Federal Register, 800 North Capitol Street, NW., suite 700, Washington, DC.

(3) American National Standards Institute (ANSI) standards are available from ANSI Inc., 11 West 42nd Street, 13th floor, New York, NY 10036, telephone 212-642-4900.

(i) ANSI Standard S1.4-1983, Specification for Sound Level Meters, including Amendment S1.4A-1985.

(ii) [Reserved]

(4) American Society for Testing Materials (ASTM) are available from 1916 Race Street, Philadelphia, PA 19103, telephone 215-299-5400.

(i) ASTM Specification B33-91, Standard Specifications for Tinned Soft or Annealed Copper Wire for Electrical Purposes.

(ii) [Reserved]

(5) Bell Communications Research (Bellcore) standards are available from

Bellcore Customer Service, 8 Corporate Place, Piscataway, NJ 08854, telephone 1-800-521-2673.

(i) TR-TSY-000008, Issue 2, August 1987, Digital Interface between the SLC 96 Digital Loop Carrier System and a Local Digital Switch.

(ii) Bell Communications Research (Bellcore) document TR-TSY-000057, Issue 1, April 1987, including Revision 1, November 1988, Functional Criteria for Digital Loop Carrier Systems.

(iii) Bell Communications Research (Bellcore) Document TR-NWT-000303, Issue 2, December 1992, including Revision 1, December 1993, Integrated Digital Loop Carrier System Generic Requirements, Objectives, and Interface.

(6) Federal Standard H28, Screw-Thread Standards for Federal Services, March 31, 1978, including Change Notice 1, May 28, 1986; Change Notice 2, January 20, 1989; and Change Notice 3, March 12, 1990. Copies may be obtained from the General Services Administration, Specification Section, 490 East L'Enfant Plaza SW, Washington, DC 20407, telephone 202-755-0325.

(7) IEEE standards are available from IEEE Service Center, 445 Hoes Lane, P.O. Box 1331, Piscataway, NJ 08854, telephone 1-800-521-2673.

(i) IEEE Standard 455-1985, Standard Test Procedure for Measuring Longitudinal Balance of Telephone Equipment Operating in the Voice Band.

(ii) [Reserved]

(8) RUS standards are available from Publications and Directives Management Branch, Administrative Services Division, Rural Utilities Service, room 0180, South Building, U.S. Department of Agriculture, Washington, DC 20250-1500.

(i) RUS Bulletin 345-50, PE-60 (Sept 1979), RUS Specification for Trunk Carrier Systems.

(ii) [Reserved]

(b) *Types of requirements.* (1) Unless otherwise indicated, the requirements listed in this section are considered to be fixed requirements.

(2) The concentrator system shall communicate with standard T1 digital transmission format at a minimum between the concentrator and central office terminals. Analog conversion functions at remote and central office terminals shall be capable of being eliminated to accommodate end-to-end digital transmission.

(3) The LC shall operate properly as an integral part of the telephone network when connected to physical or carrier derived circuits and central offices meeting RUS specifications and other generally accepted telecommunications practices, such as

Bellcore documents TR-NWT-000303, Integrated Digital Loop Carrier System Generic Requirements, Objectives and Interface; TR-TSY-000008, Digital Interface between the SLC 96 Digital Loop Carrier System and a Local Digital Switch; and TR-TSY-000057, Functional Criteria for Digital Loop Carrier Systems.

(4) For RUS acceptance consideration of a LC, the manufacturer must certify and demonstrate that all requirements specified in this section are available and in compliance with this section.

(5) Certain requirements are included in this section for features which may not be needed for every application. Such features are identifiable by the inclusion in the requirements of some such phrase as "when specified by the owner" or "as specified by the owner." In some cases where an optional feature will not be required by an owner, either now or in the future, a system which does not provide this feature shall be considered to be in compliance with the specification for the specific installation under consideration, but not in compliance with the entire specification.

(6) The owner may properly request bids from any supplier of an RUS accepted LC whose system provides all the features which will be required for a specific installation.

(7) When required by the owner, the supplier shall state compliance to the Carrier Serving Area (CSA) requirements, as stated in Bell Communications Research (Bellcore) Standard TR-TSY-000057, Functional

Criteria for Digital Loop Carrier Systems.

(c) *Reliability.* (1) The failure rate of printed circuit boards shall not exceed an average of 2.0 percent per month of all equipped cards in all system terminals during the first 3 months after cutover, and shall not exceed an average of 1.0 percent per month of all equipped cards in all system terminals during the second 3-month period. The failure rate for the equipment shall be less than 0.5 percent per month of all equipped cards in all system terminals after 6 months. A failure is considered to be the failure of a component on the PC board which requires it to be repaired or replaced.

(2) The line concentrator terminal units shall be designed such that there will be no more than 4 hours of total outages in 20 years.

(d) *System type acceptance tests.* General test results will be required on each system type. Any system provided in accordance with this section shall be capable of meeting any requirement in this section on a spot-check basis.

(e) *Features required.* The network control equipment and peripheral equipment shall be comprised of solid-state and integrated circuitry components as far as practical and in keeping with the state-of-the-art and economics of the subject system.

(f) *Subscriber lines.*—(1) *General.* (i) The remote LC units shall operate satisfactorily with subscriber lines which meet all of the conditions under the bidder's specifications and all the requirements of this section. This section recognizes that the loop limit of

the line concentrator is dependent upon the transmission facility between the LC central office termination and the LC remote unit. When voice frequency (physical) circuits are used, the loop limit from the COE to the subscriber shall be 1900 ohms (including the telephone set). When electronically derived circuits (carrier, lightwave, etc.) are used, the loop limits of the electronic system will control. The bidder shall identify the loop limits of the equipment to be supplied.

(ii) There should be provisions for such types of lines as ground start, loop start, regular subscriber, pay stations, etc.

(2) *Dialing.* (i) *General.* The line concentrator remote and central office terminal equipment shall satisfactorily transmit dialing information when used with subscriber dials having a speed of operation between 8 and 12 dial pulses per second and a break period of 55 to 65% of the total signaling period.

(ii) *Subscriber dial interdigital time.* The remote and central office LC equipment shall permit satisfactory telecommunications operation when used with subscriber rotary dial interdigital times of 200 milliseconds minimum, and pushbutton dialing with 50 milliseconds minimum.

(iii) *Subscriber line pushbutton dialing frequencies.* The frequency pairs assigned for pushbutton dialing when provided by the central office shall be as listed in this paragraph (f)(2)(iii), with an allowable variation of ±1.5 percent:

Low group frequencies (Hz)	High group frequencies (Hz)			
	1209	1336	1477	1633
697 .....	1	2	3	Spare.
770 .....	4	5	6	Spare.
852 .....	7	8	9	Spare.
941 .....	*	0	#	Spare.

(3) *Ringling.* (i) When LC ringling is generated at the remote end, it shall be automatic and intermittent and shall be cut off from the called line upon removal of the handset at the called station during either the ringling or silent period.

(ii) When ringling generators are provided in the LC on an ancillary basis, they shall be accepted or technically accepted by RUS.

(iii) Where ringling is generated at the remote end, the ringling system shall provide sufficient ringling on a bridged basis over the voltage and temperature limits of this specification and over subscriber loops within the limits stated

by the manufacturer. The manufacturer shall state the minimum number (not less than two) of main station ringers that can be used for each ringling option available.

(g) *Traffic.* (1)(i) The minimum grade of service for traffic in the line concentrator shall be B=.005 using the Traffic Table, based on the Erlang Lost-Calls-Cleared Formula. Required grade of service, traffic assumptions and calculations for the particular application being implemented shall be supplied by the bidder.

(ii) Service to customers served by a traffic sensitive LC should not be noticeably different than the service to

customers served by the dedicated physical pairs from the central office so that uniform grade of service will be provided to all customers in any class of service. Reference § 1755.522(p)(1)(i), RUS General Specification for Digital, Stored Program Controlled Central Office Equipment.

(2) *Traffic and Plant Registers.* Traffic measurements consist of three types—peg count, usage, and congestion. A peg count register scores one count per call attempt per circuit group such as trunks, digit receivers, senders, etc. Usage counters measure the traffic density in networks, trunks and other circuit groups. Congestion registers score the

number of calls which fail to find an idle circuit in a trunk group or to find an idle path through the switching network when attempting to connect two given end points. These conditions constitute "network blocking."

(3) When required, traffic data will be stored in electronic storage registers or a block of memory consisting of one or more traffic counters for each item to be measured. The bidder shall indicate what registers are to be supplied, their purpose and the means for displaying the information locally (or at a remote location when available).

(h) *Transmission requirements.* (1) *General.* Unless otherwise stated, the requirements in paragraphs (h) (2) through (20) of this section are specified in terms of analog measurements made from Main Distributing Frame (MDF) terminals to MDF terminals excluding cabling loss.

(2) *Telephone transmitter battery supply.* A minimum of 20 milliamperes, dc, shall be provided for the transmitter of the telephone set at the subscriber station under all loop conditions specified by the bidder. The telephone

set is assumed to have a resistance of 200 ohms.

(3) *Impedance—subscriber loops.* For the purpose of this section, the input impedance of all subscriber loops served by the equipment is arbitrarily considered to be 900 ohms in series with 2.16 microfarad capacitor at voice frequencies.

(4) *Battery noise.* Noise across the remote terminal battery at power panel distribution bus terminals shall not exceed 35 dBrnC during the specified busy hour.

(5) *Stability.* The long-term allowable variation in loss through the line concentrator system shall be  $\pm 0.5$  dB from the loss specified by the bidder.

(6) *Return loss.* The specified return loss values are determined by the service and type of port at the measuring end. Two-wire ports are measured at 900 ohms in series with 2.16 microfarads, and 4-wire ports are measured at 600 ohms resistive. When other balance networks are supplied, test equipment arranged for operation with the supplied network(s) may be used. The requirement given shall meet the following cited values on each balance network available in the system:

Line-to-Line or Line-to-Trunk (2-Wire)  
Echo Return Loss (ERL)—18 dB, Minimum  
Singing Return Loss (SRL)—Low—15 dB,  
Minimum  
Singing Return Loss (SRL)—High—18 dB,  
Minimum

(7) *Longitudinal balance.* The minimum longitudinal balance, with dc loop currents between 20 to 70 mA, shall be 60 dB at all frequencies between 60 and 2000 Hz, 55 dB at 2700 Hz and 50 dB at 3400 Hz. The method of measurement shall be as specified in the IEEE standard 455, "Standard Testing Procedure for Measuring Longitudinal Balance of Telephone Equipment Operating in the Voice Band." Source voltage level shall be 10 volts root mean square (rms) where conversation battery feed originates at the remote end.

(8) *60 hz longitudinal current immunity.* The LC 60 Hz longitudinal current immunity shall be measured in accordance with Figure 1 of this section. Under test conditions cited on Figure 1 of this section, the system noise shall be 23 dBrnC or less as follows:

BILLING CODE 3410-15-P

Figure 1

Measuring the Effects of Low Frequency Induction

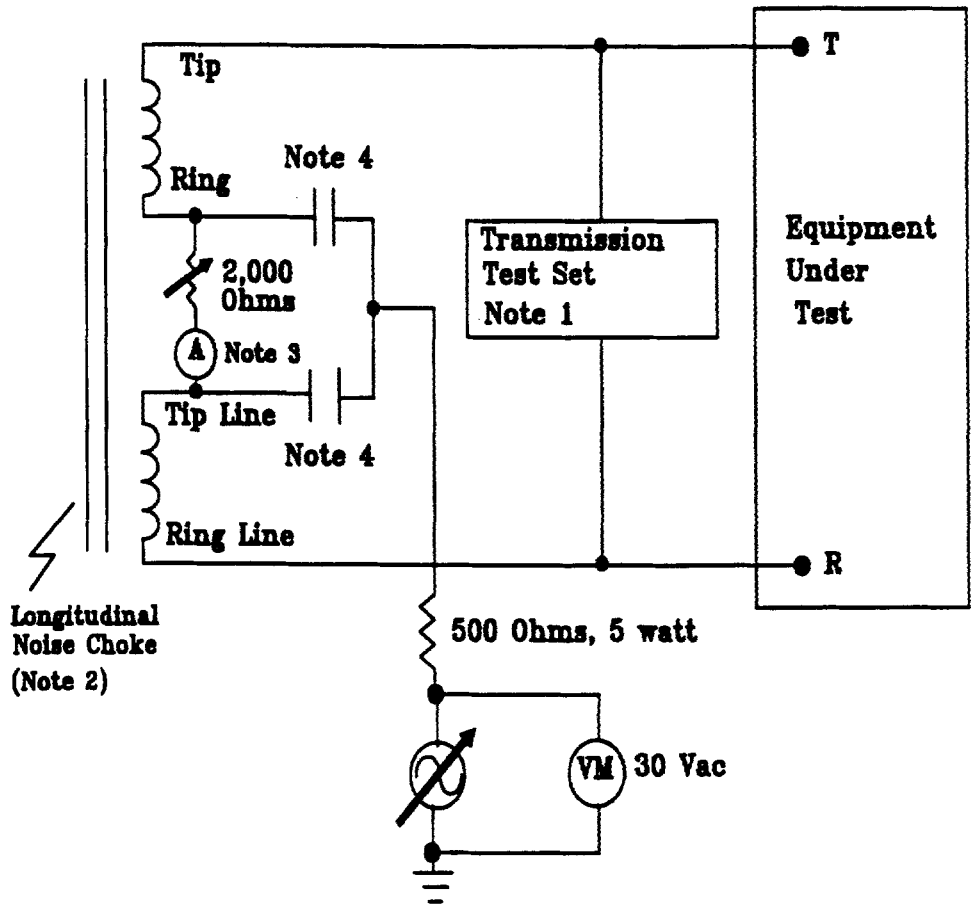

Notes:

1. Wilcom T194C or Equivalent (900 ohm termination, C-message weighting, hold coil off)
2. SNC Noise Choke 35 W, or equivalent
3. Test at 0.020 Adc and 0.070 Adc
4.  $2 \pm 0.001$  microfarad, 150 Vdc

(9) *Steady noise (idle channel at 900 ohm impedance)*. Steady noise: Measure on terminated call. Noise measurements shall comply with the following:

Maximum—23 dBrnC0  
 Average—18 dBrnC0 or Less  
 3KHz Flat—Less than 35 dBrnO as an Objective

(10) *Impulse noise*. LC central office terminal equipment shall have an impulse noise limit of not more than five counts exceeding 54 dBrnC0 voice band weighted in a 5-minute period on six such measurements made during the busy hour. A WILCOM T-194C Transmission Test Set, or equivalent, should be used for the measurements. The measurement shall be made by establishing a normal connection from the noise counter through the switching equipment in its off-hook condition to a quiet termination of 900 ohms impedance. Office battery and signaling circuit wiring shall be suitably segregated from voice and carrier circuit wiring, and frame talking battery filters provided, if and as required, in order to meet these impulse noise limits.

(11) *Crosstalk coupling*. Worst case equal level crosstalk shall be 65 dB minimum in the range 200 to 3400 Hz. This shall be measured between any two paths through the system by connecting a 0 dBm0 level tone to the disturbing pair.

(12) *Digital error rate*. The digital line concentrator shall not introduce more than one error in 10<sup>8</sup> bits averaged over a 5-minute period, excluding the least significant bit.

(13) *Quantizing distortion*. (i) The system shall meet the following requirements:

Input level (dBm0) 1004 or 1020 Hz	Minimum signal to distortion with C-message weighting
0 to -30 .....	33 dB
-30 to -40 .....	27 dB
-40 to -45 .....	22 dB

(ii) Due to possible loss of the least significant bit on direct digital connections, a signal to distortion degradation of up to 2 dB may be allowed where adequately justified by the bidder.

(14) *Overload level*. The overload level shall be +3 dBm0.

(15) *Gain tracking (linearity)* shall meet the following requirements:

Input signal level <sup>1</sup>	Maximum gain deviation
+3 to -37 dBm0 .....	±0.5 dB

Input signal level <sup>1</sup>	Maximum gain deviation
-37 to -50 dBm0 .....	±1 dB

<sup>1</sup> 1004 Hz reference at 0 dBm0.

(16) *Frequency response (loss relative to 1004 Hz)* for line-to-line (via trunk group or intra-link) connections shall meet the following requirements:

Frequency (Hz)	Loss at 0 dBm0 input <sup>1</sup>
60 .....	20 dB Min. <sup>2</sup>
300 .....	-1 to +3 dB
600 to 2400 .....	+1 dB
3400 .....	-1 to +3 dB

<sup>1</sup> (-) means less loss and (+) means more loss.

<sup>2</sup> Transmit End.

(17) *Envelope delay distortion*. On any properly established connection, the envelope delay distortion shall not exceed the following limits:

Frequency (Hz)	Microseconds
1000 to 2600 .....	190
800 to 2800 .....	350
600 to 3000 .....	500
400 to 3200 .....	700

(18) *Absolute delay*. The absolute one-way delay through the line concentrator, excluding delays associated with the central office switching equipment, shall not exceed 1000 microseconds analog-to-analog measured at 1800 Hz.

(19) *Insertion loss*. The insertion loss in both directions of transmission at 1004 Hz shall be included in the insertion loss requirements for the connected COE switch and shall not increase the overall losses through the combined equipment beyond the values for the COE alone, when operated through a direct digital interface. Systems operated with a (VF) line circuit interface may introduce up to 3 dB insertion loss. Reference § 1755.522(q)(3).

(20) *Detailed requirements for direct digital connections*. (i) This paragraph (h)(20) covers the detailed requirements for the provision of interface units which will permit direct digital connection between the host central office and line concentrator subscriber terminals over digital facilities. The digital transmission system shall be compatible with T1 type span lines using a DS1 interface and other digital interfaces that may be specified by the owner. The RUS specification for the T1 span line equipment is PE-60. Other span line techniques may also be used. Diverse span line routing may be used when specified by the owner.

(ii) The output of a digital-to-digital port shall be Pulse Code Modulation (PCM), encoded in eight-bit words using the mu-255 encoding law and D3 encoding format, and arranged to interface with a T1 span line.

(iii) Signaling shall be by means of Multifrequency (MF) or Dual Pulsing (DP) and the system which is inherent in the A and B bits of the D3 format. In the case where A and B bits are not used for signaling or system control, these bits shall only be used for normal voice and data transmission.

(iv) When a direct digital interface between the span line and the host central office equipment is to be implemented, the following requirements shall be met:

(A) The span line shall be terminated in a central office as a minimum a DS1 (1.544Mb/s) shall be provided;

(B) The digital central office equipment shall be programmed to support the operation of the digital port with the line concentrator subscriber terminal;

(C) The line concentrator subscriber terminal used with a direct digital interface shall be interchangeable with the subscriber terminal used with a central office terminal.

(i) *Alarms*. The system shall send alarms for such conditions as blown fuses, blocked controls, power failure in the remote terminal, etc., along with its own status indication and status of dry relay contact closures or solid-state equivalent to the associated central office alarm circuits. Sufficient system alarm points shall be provided from the remote terminal to report conditions to the central office alarm system. The alarms shall be transmitted from the remote terminal to the central office terminal as long as any part of the connecting link is available for this transmission. Fuses shall be of the alarm and indicator type, and their rating designated by numerals or color code on fuse positions.

(j) *Electrical protection*—(1) *Surge protection*. (i) Adequate electrical protection of line concentrator equipment shall be included in the design of the system. The characteristics and application of protection devices must be such that they enable the line concentrator equipment to withstand, without damage or excessive protector maintenance, the dielectric stresses and currents that are produced in line-to-ground and tip-to-ring circuits through the equipment as a result of induced or conducted lightning or power system fault-related surges. All wire terminals connected to outside plant wire or cable pairs shall be protected from voltage and current surges.

(ii) Equipment must pass laboratory tests, simulating a hostile electrical environment, before being placed in the field for the purpose of obtaining field experience. For acceptance consideration RUS requires manufacturers to submit recently

completed results (within 90 days of submittal) of data obtained from the prescribed testing. Manufacturers are expected to detail how data and tests were conducted. There are five basic types of laboratory tests which must be applied to exposed terminals in an effort

to determine if the equipment will survive. Figure 2 of this section, Summary of Electrical Requirements and Tests, identifies the tests and their application as follows:

FIGURE 2.—SUMMARY OF ELECTRICAL REQUIREMENTS AND TESTS

Test	Application criteria	Peak voltage or current	Surge waveshape	Number of applications and maximum time between	Comments
Current surge ....	Low impedance paths exposed to surges.	500A or lesser current (see fig. 4).	10x1000 μs .....	5 each polarity at 1 minute intervals.	None.
60 Hz current carrying.	High or low impedance paths exposed to surges.	10A rms or lesser current (see fig. 6).	11 Cycles of 60 Hz (0.183 Sec.).	3 each at 1 minute intervals.	None.
AC Power service surge voltage.	AC power service connection.	2500V or +3 σ clamping V of arrester employed at 10kV/μs.	1.2x50 μs .....	5 each polarity at 1 minute intervals.	AC arrester, if used, must be removed. Communications line arresters, if used, remain in place.
Voltage surge ...	High impedance paths exposed to surges.	1000V or +3 σ dc breakdown of arrester employed.	10x1000 μs .....	5 each polarity at 1 minute intervals.	All primary arresters, if used, must be removed.
Arrester re-sponse delay.	Paths protected by arresters, such as gas tubes, with breakdown dependent on V. rate of rise.	+3 σ breakdown of arrester employed at 100V/μs of rise.	100V/μs rise decay to 1/2 V. in tube's delay time.	5 each polarity at 1 minute intervals.	All primary arrestors, if used, must be removed.

(iii) Electrical protection requirements for line concentrator equipment can be summarized briefly as follows:

(A) Current surge tests simulate the stress to which a relatively low impedance path may be subjected before main frame protectors break down. Paths with a 100 Hz impedance of 50 ohms or less shall be subjected to current surges, employing a 10 x 1000

microsecond waveshape as defined in Figure 3 of this section, Surge Waveshape. For the purpose of determining this impedance, arresters which are mounted within the equipment are to be considered zero impedance. The crest current shall not exceed 500A; however, depending on the impedance of the test specimen this value of current may be lower. The crest

current through the sample, multiplied by the sample's 100 Hz impedance, shall not exceed 1000 V. Where sample impedance is less than 2 ohms, peak current shall be limited to 500A as shown in Figure 4 of this section, Current Surge Tests. Figures 3 and 4 follow:

BILLING CODE 3410-15-P

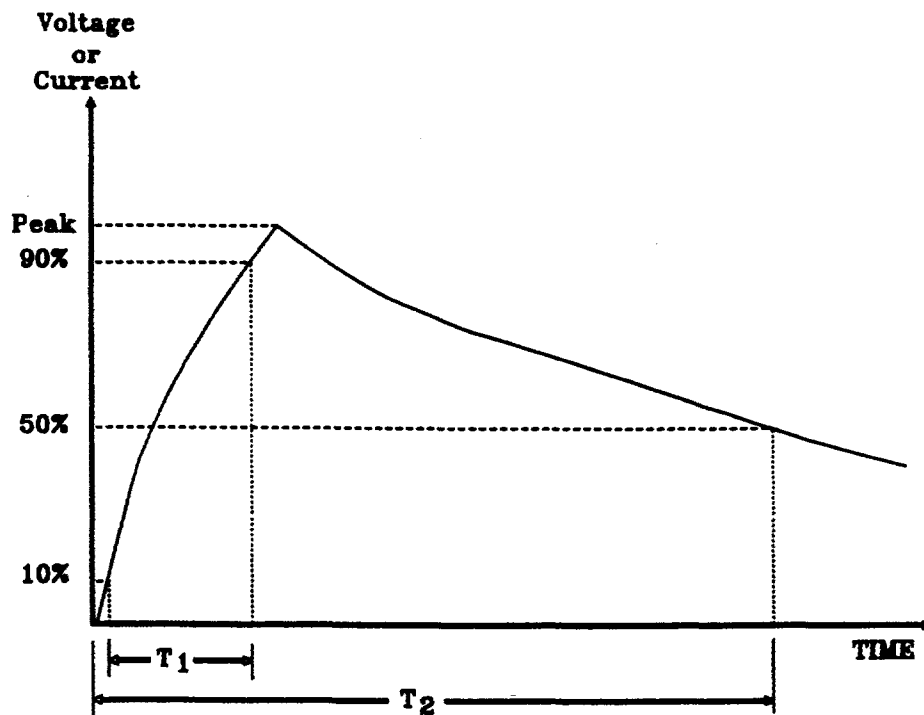

Figure 3

**Explanation of Surge Waveshape**

Surge Waveshape is defined as follows:

Rise Time x Time to Decay to Half Crest Value  
(For example, 10 x 1000  $\mu$ s)

Notes:  $T_1$  = Time to determine the rate of rise. The rate of rise is determined as the slope between 10% and 90% of peak voltage or current.

$T_2$  = Time to 50% of peak voltage (decay to half value).

Figure 4

Current Surge Test

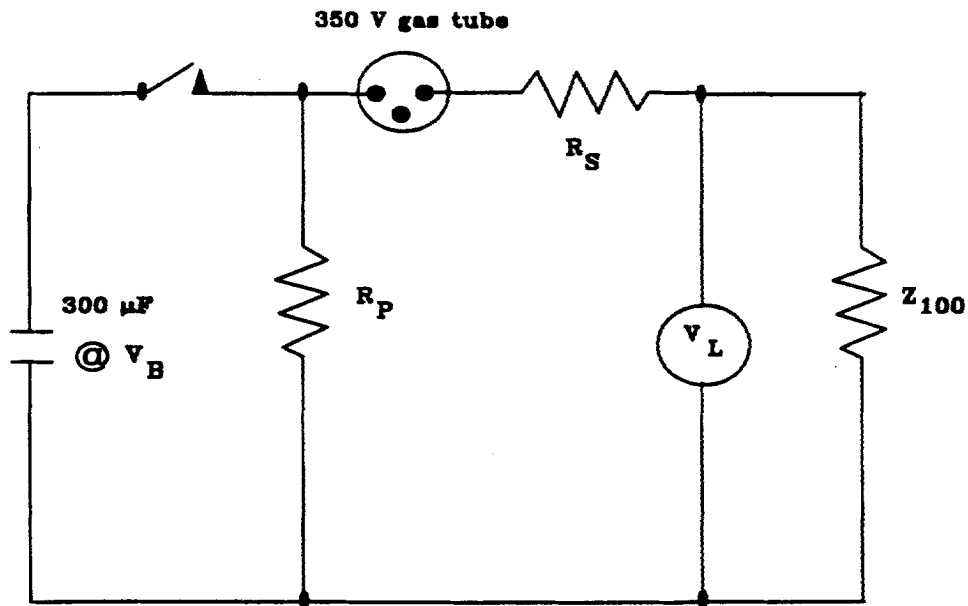

- $V_L$  = Not to exceed 1000V
- $V_B$  = Charging Voltage
- $Z_{100}$  = Test Specimen Impedance to be measured at 100 Hz.
- $R_P$  = Parallel Resistance (Waveshape)
- $R_S$  = Series Resistance (Current Limiting)

$Z_{100}$	$R_S$	$R_P$	$V_B$
0	5	$\infty$	2500
1	4	$\infty$	2500
2	3	$\infty$	2500
3	2	$\infty$	1670
4	1	$\infty$	1250
5	0	$\infty$	1000
7.5	0	15	1000
10	0	10	1000
15	0	7.5	1000
20	0	6.7	1000
25	0	6.25	1000
30	0	6	1000
40	0	5.7	1000
50	0	5.5	1000

(B) Sixty Hertz (60 Hz) current carrying tests shall be applied to simulate an ac power fault which is conducted to the unit over the cable pairs. The test shall be limited to 10 amperes Root Mean Square (rms) of 60 Hz ac for a period of 11 cycles (0.1835 seconds) and shall be applied longitudinally from line to ground.

(C) AC power service surge voltage tests shall be applied to the power input terminals of ac powered devices to simulate switching surges or lightning-induced transients on the ac power system. The test shall employ a 1.2 x 50 microsecond waveshape with a crest voltage of 2500 V. Communications line

protectors may be left in place for these tests.

(D) Voltage surge tests which simulate the voltage stress to which a relatively high impedance path may be subjected before primary protectors break down and protect the circuit. To ensure coordination with the primary protection while reducing testing to the minimum, voltage surge tests shall be conducted at a 1000 volts with primary arresters removed for devices protected by carbon blocks, or the +3 sigma dc breakdown voltage of other primary arresters. Surge waveshape should be 10 x 1000 microseconds.

(E) Arrester response delay tests are designed to stress the equipment in a manner similar to that caused by the delayed breakdown of gap type arresters when subjected to rapidly rising voltages. Arresters shall be removed for these tests, the peak surge voltage shall be the +3 sigma breakdown voltage of the arrester in question on a voltage rising at 100 V per microsecond, and the time for the surge to decay to half voltage shall equal at least the delay time of the tube as explained in Figure 5 of this section, Arrester Response Delay Time as follows:

BILLING CODE 3410-15-P

Figure 5

---

**Explanation of Arrester Response Delay Time**

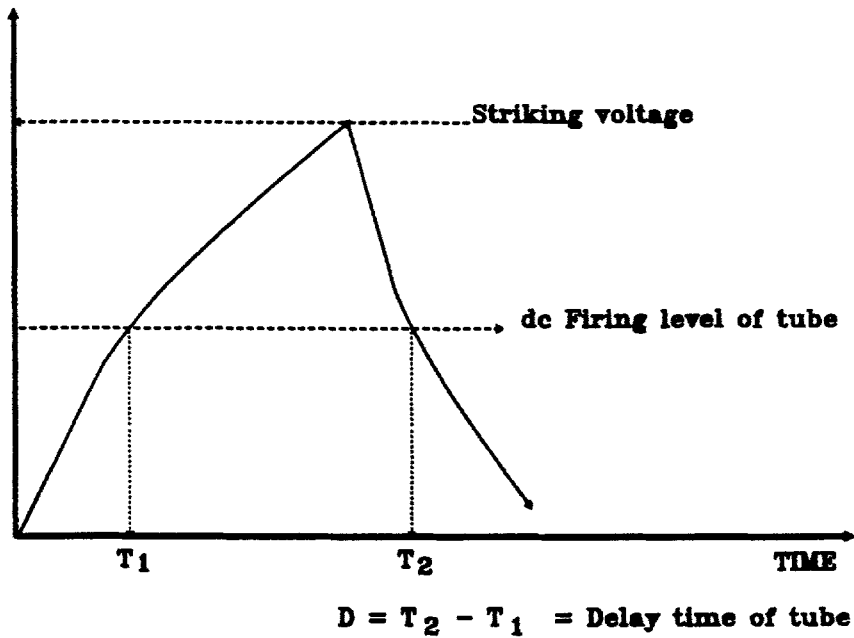

**Note:** The delay time is that period of time when the potential across an arrester exceeds its dc firing level.

---

(iv) Tests shall be conducted in the following sequence. As not all tests are required in every application, non-applicable tests should be omitted:

- (A) Current Impulse Test;
- (B) Sixty Hertz (60 Hz) Current Carrying Tests;
- (C) AC Power Service Impulse Voltage Test;

- (D) Voltage Impulse Test; and
- (E) Arrester Response Delay Time Test.

(v) A minimum of five applications of each polarity for the surge tests and three for the 60 Hz Current Carrying Tests are the minimum required. All tests shall be conducted with not more than 1 minute between consecutive

applications in each series of three or five applications to a specific configuration so that heating effects will be cumulative. See Figure 6 of this section, 60 Hz Current Surge Tests as follows:

BILLING CODE 3410-15-P

Figure 6

60 Hz Current Surge Test

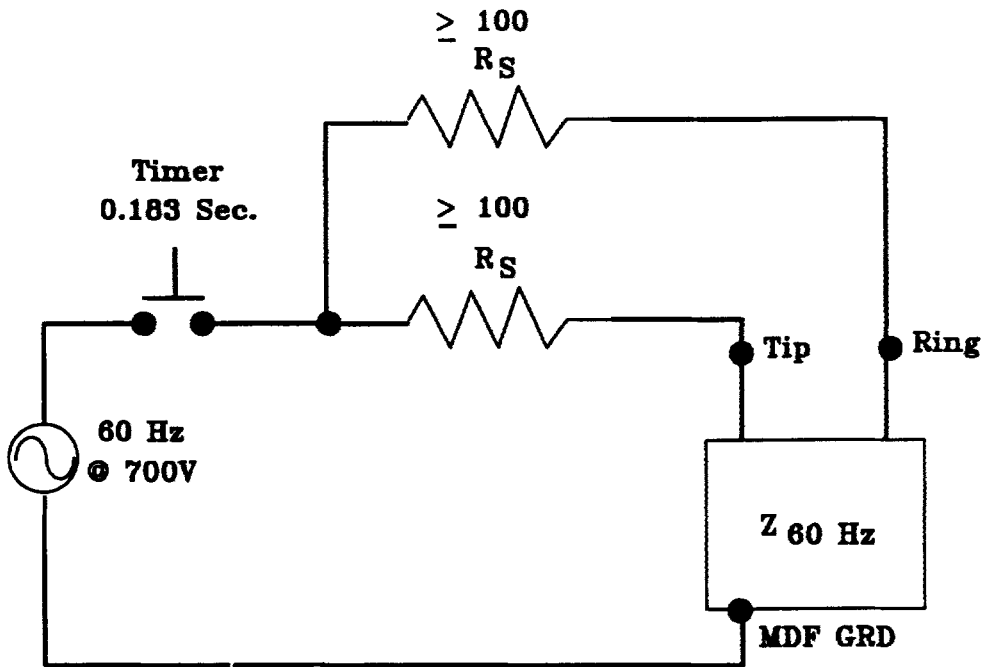

- V - 700 Volts root mean square (rms) (Approximately 1000V Peak).
- Z<sub>60</sub> - Test specimen impedance to be measured at 60 Hz.
- R<sub>S</sub> - Series Resistance (current limiting) in each side of line. (Source impedance never less than 50 Ω longitudinal.)

Z <sub>60</sub> Hz	R <sub>S</sub>
0	140
10	120
20	100
50	100
Over 50	100

(vi) Tests shall be applied between each of the following terminal combinations for all line operating conditions:

- (A) Line tip to ring;
- (B) Line ring to ground;
- (C) Line tip to ground; and
- (D) Line tip and ring tied together to ground.

(2) *Dielectric strength.* (i) Arresters shall be removed for all dielectric strength tests.

(ii) Direct current potentials shall be applied between all line terminals and the equipment chassis and between these terminals and grounded equipment housings in all instances where the circuitry is dc open circuit from the chassis, or connected to the chassis through a capacitor. The duration of all dielectric strength tests shall be at least 1 second. The applied potential shall be at a minimum equal to the plus 3 sigma dc breakdown voltage of the arrester, provided by the line concentrator manufacturer.

(3) *Insulation resistance.* Following the dielectric tests, the insulation resistance of the installed electrical circuits between wires and ground, with the normal equipment grounds removed, shall not be less than 10 megohms at 500 volts dc at a temperature of 68 °F (20 °C) and at a relative humidity of approximately 50 percent. The measurement shall be made after the meter stabilizes, unless the requirement is met sooner. Arresters shall be removed for these tests.

(4) *Self-protection.* (i) All components shall be capable of being continuously energized at rated voltage without injury. Design precautions must be taken to prevent damage to other equipment components when a particular component fails.

(ii) Printed circuit boards or similar equipment employing electronic components should be self-protecting against external grounds applied to the connector terminals. Board components and coatings applied to finished products shall be of such material or so treated that they will not support combustion.

(iii) Every precaution shall be taken to protect electrostatically sensitive components from damage during handling. This shall include written instructions and recommendations.

(k) *Miscellaneous—(1) Interconnect wire.* All interconnect wire shall be of soft annealed tinned copper wire meeting the requirements of ASTM Specification B33-91 and of suitable cross-section to provide safe current carrying capacity and mechanical strength. The insulation of installed wire, connected to its equipment and

frames, shall be capable of withstanding the same insulation resistance and dielectric strength requirements as given in paragraphs (j)(2) and (j)(3) of this section at a temperature of 120 °F (49 °C), and a relative humidity of 90 percent.

(2) *Wire wrapped terminals.* These terminals are preferred and where used shall be of a material suitable for wire wrapping. The connections to them shall be made with a wire wrapping tool with the following minimum number of successive non-overlapping turns of bare tinned copper wire in contact with each terminal:

- (i) 6 turns of 30 gauge;
- (ii) 6 turns of 26 gauge;
- (iii) 6 turns of 24 gauge; or
- (iv) 5 turns of 22 gauge.

(3) *Protection against corrosion.* All metal parts of equipment frames, distributing frames, cable supporting framework and other exposed metal parts shall be constructed of corrosion resistant materials or materials plated or painted to render them adequately corrosion resistant.

(4) *Screws and bolts.* Screw threads for all threaded securing devices shall be of American National Standard form in accordance with Federal Standard H28, unless exceptions are granted to the manufacturer of the switching equipment. All bolts, nuts, screws, and washers shall be of nickel-copper alloy, steel, brass or bronze.

(5) *Environmental requirements.* (i) The bidder shall specify the environmental conditions necessary for safe storage and satisfactory operation of the equipment being bid. If requested, the bidder shall assist the owner in planning how to provide the necessary environment for the equipment.

(ii) To the extent practicable, the following temperature range objectives shall be met:

(A) For equipment mounted in central office and subscriber buildings, the carrier equipment shall operate satisfactorily within an ambient temperature range of 32 °F to 120 °F (0 °C to 49 °C) and at 80 percent relative humidity between 50 °F and 100 °F (10 °C and 38 °C); and

(B) Equipment mounted outdoors in normal operation (with cabinet doors closed) shall operate satisfactorily within an ambient temperature range (external to cabinet) of -40 °F to 140 °F (-40 °C to 60 °C) and at 95 percent relative humidity between 50 °F to 100 °F (10 °C to 38 °C). As an alternative to the (60 °C) requirement, a maximum ambient temperature of 120 °F (49 °C) with equipment (cabinet) exposed to direct sunlight may be substituted.

(6) *Stenciling.* Equipment units and terminal jacks shall be adequately designated and numbered. They shall be stenciled so that identification of equipment units and leads for testing or traffic analysis can be made without unnecessary reference to prints or descriptive literature.

(7) *Quantity of equipment bays.* Consistent with system arrangements and ease of maintenance, space shall be provided on the floor plan for an orderly layout of future equipment bays. Readily accessible terminals will be provided for connection to interbay and frame cables to future bays. All cables, interbay and intrabay (excluding power), if technically feasible, shall be terminated at both ends by connectors.

(8) *Radio and television interference.* Measures shall be employed by the bidders to limit the radiation of radio frequencies generated by the equipment so as not to interfere with radio, television receivers, or other sensitive equipment.

(9) *Housing.* (i) When housed in a building supplied by the owner, a complete floor plan including ceiling height, floor loading, power outlets, cable entrances, equipment entry and travel, type of construction, and other pertinent information shall be supplied.

(ii) In order to limit corrosion, all metal parts of the housing and mounting frames shall be constructed of suitable corrosion resistant materials or materials protectively coated to render them adequately resistant to corrosion under the climatic and atmospheric conditions existing in the area in which the housing is to be installed.

(10) *Distributing frame.* (i) The line concentrator terminal equipment located at the central office shall be protected by the central office main distribution frame. The bidder may supply additional protection capability as appropriate. All protection devices (new or existing) shall be arranged to operate in a coordinated manner to protect equipment, limit surge currents, and protect personnel.

(ii) The distributing frame shall provide terminals for terminating all incoming cable pairs. Arresters shall be provided for all incoming cable pairs, or for a smaller number of pairs if specified.

(iii) The current carrying capacity of each arrester and its associated mounting shall coordinate with a #22 gauge copper conductor without causing a self-sustaining fire or permanently damaging other arrester positions. Where all cable pairs entering the housing are #24 gauge or finer, the arresters and mountings need only

coordinate with #24 gauge cable conductors.

(iv) Remote terminal protectors may be mounted and arranged so that outside cable pairs may be terminated on the left or bottom side of protectors (when facing the vertical side of the MDF) or on the back surface of the protectors. Means for easy identification of pairs shall be provided.

(v) Protectors shall have a "dead front" (either insulated or grounded) where live metal parts are not readily accessible.

(vi) Protectors shall be provided with an accessible terminal of each incoming conductor which is suitable for the attachment of a temporary test lead. They shall also be constructed so that auxiliary test fixtures may be applied to open and test the subscriber's circuit in either direction. Terminals shall be suitable for wire wrapped connections or connectorized.

(vii) If specified, each protector group shall be furnished with a factory assembled tip cable for splicing to the outside cable; the tip cable shall be 20 feet (6.1 m) in length, unless otherwise specified. Tip cable used shall be RUS accepted.

(viii) Protector makes and types used shall be RUS accepted.

(l) *Power equipment*—(1) *General*. When specified, batteries and charging

equipment shall be supplied for the remote terminal of the line concentrator.

(2) *Operating voltage*. (i) The nominal operating voltage of the central office and remote terminal shall be 48 volts dc, provided by a battery with the positive side tied to system ground.

(ii) Where equipment is dc powered, it must operate satisfactorily over a range of 50 volts  $\pm$  6 volts dc.

(iii) Where equipment is ac powered, it must operate satisfactorily over a range of 120 $\pm$ 10 volts or 220 $\pm$ 10 volts ac.

(3) *Batteries*. (i) Unless otherwise specified by the owner, sealed batteries shall be supplied for the remote line concentrator terminal.

(ii) The batteries shall have an ampere hour load capacity of no less than 8 busy hours. When an emergency ac supply source is available, the battery reserve may be reduced to 3 busy hours.

(iii) The batteries shall be sealed when they are mounted in the cabinet with the concentrator equipment.

(iv) When specified by the owner, battery heaters shall be supplied in a bidder-furnished housing.

(4) *Charging equipment*. (i) One charger capable of carrying the full dc power load of the remote terminal shall be supplied unless otherwise specified by the owner.

(ii) Charging shall be on a full float basis. The rectifiers shall be of the full

wave, self-regulating, constant voltage, solid-state type and shall be capable of being turned on and off manually.

(iii) When charging batteries, the voltage at the battery terminals shall be adjustable and shall be set at the value recommended for the particular battery being charged, provided it is not above the maximum operating voltage of the central office switching equipment. The voltage shall not vary more than  $\pm$ 0.02 volt dc per cell between 10% load and 100% load. Between 3% and 10% load, the output voltage shall not vary more than  $\pm$ 0.04 volt dc per cell. Beyond full load current the output voltage shall drop sharply. The above output voltage shall be maintained with input line voltage variations of plus or minus 10 percent. Provision shall be made to manually change the output voltage of the rectifier to 2.25 volts per cell to provide an equalization charge on the battery.

(iv) The charger noise, when measured with a suitable noise measuring set and under the rated battery capacitance and load conditions, shall not exceed 22 dB<sub>BrnC</sub>. See Figure 7 of this section, Charger Noise Test as follows:

BILLING CODE 3410-15-P

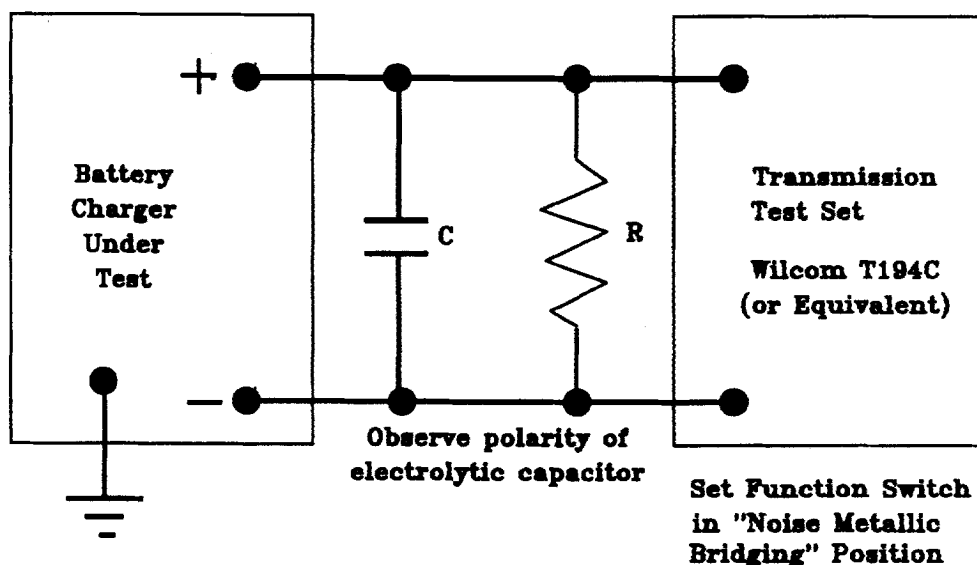

Figure 7

**Charger Noise Test**

Note (1) The manufacturer may elect to eliminate the capacitor C from the measurement.

Capacitance C in  $\mu\text{F}$  = 30,000  $\mu\text{F}$  per ampere-hour per cell. For example, 25 cells at 100 ampere-hour would be equivalent to a capacitance of:

$$(30,000 \times 100) / 25 = 120,000 \mu\text{F}$$

- (2) The value of the resistive load R is determined by the nominal battery voltage in volts divided by the full load rating in amperes. For example, for a 48 volt battery and a full load current of 24 amperes, the load resistance R is  $48/24 = 2$  ohms of appropriate power handling capacity.

(v) The charging equipment shall be provided with a means for indicating a failure of charging current whether due to ac power failure, an internal failure in the charger, or to other circumstances which might cause the output voltage of the charger to drop below the battery voltage. Where a supplementary constant current charger is used, an alarm shall be provided to indicate a failure of the charger.

(vi) Audible noise developed by the charging equipment shall be kept to a minimum. Acoustic noise resulting from operation of the rectifier shall be expressed in terms of dB indicated on a sound level meter conforming to American National Standards Institute S1.4, and shall not exceed 65 dB (A-weighting) measured at any point 5 feet (1.5m) from any vertical surface of the rectifier.

(vii) The charging equipment shall be designed so that neither the charger nor the central office equipment is subject to damage in case the battery circuit is opened for any value of load within the normal limits.

(5) *Power panel.* (i) Battery and charger control switches, dc voltmeters, dc ammeters, fuses and circuit breakers, supervisory and timer circuits shall be provided as required. Portable or panel mounted frequency meters or voltmeters shall be provided as specified by the owner.

(ii) Power panels, cabinets and shelves, and associated wiring shall be designed initially to handle the line concentrator terminal when it reaches its ultimate capacity as specified by the owner.

(iii) The power panel shall be of the "dead front" type.

(6) *Ringling equipment.* The ringling system shall provide sufficient ringling on a bridged basis over the voltage and temperature limits of this section and over subscriber drops within the limits stated by the bidder. The ringling system shall be without operational problems such as bell tapping during dialing. The bidder shall state the minimum number (not less than two) of main station ringers that can be used for each ringling option available.

(7) *Interrupter equipment.* The interrupter may be an integral part of the system or may be part of the associated central office equipment connected to the line concentrator central office terminal.

(8) *Special systems.* Manufacturers of LC systems that operate by extending ringling current from the central office shall state their required input ringling (voltage and frequency) and the limitations on the connected subscriber loop.

(m) *Fusing requirements—(1) General.*

(i) The equipment shall be completely wired and equipped with fuses, trouble signals, and all associated equipment for the wire capacity of the frames or cabinets provided.

(ii) Design precautions shall be taken to prevent the possibility of equipment damage arising from the insertion of an electronic package into the wrong connector or the removal of a package from any connector or improper insertion of the correct card in its connector.

(2) *Fuses.* Fuses and circuit breakers shall be of an alarm and indicator type, except where the fuse or breaker location is indicated on the alarm printout. Their rating shall be designated by numerals or color codes on the fuse or the panel.

(n) *Trouble location and test—(1)*

*Equipment.* (i) Trouble indications in the system may be displayed in the form of lights on the equipment units or printed circuit boards.

(ii) When required, a jack or other connector shall be provided to connect a fault or trouble recorder (printer or display).

(2) *Maintenance system.* (i) The maintenance system shall monitor and maintain the system operation without interruption of call processing except for major failures.

(ii) The maintenance system shall be arranged to provide the ability to determine trouble to an individual card, functional group of cards, or other equipment unit.

(o) *Spare parts.* Lists of spare parts and maintenance tools as recommended by the bidder shall be provided. The cost of such tools and spare parts shall be indicated and shall not be included in the base price.

(p) *Drawings and printed material.* (1) The bidder shall supply instructional material for each line concentrator system involved at the time of delivery of the equipment. It is not the intent of this section to require system documentation necessary for the repair of individual circuit boards.

(2) Three complete sets of legible drawings shall be provided for each central office to be accessed. Each set shall include all of the following:

(i) Drawings of major equipment items such as frames, with the location of major component items of equipment shown therein;

(ii) Wiring diagrams indicating the specific method of wiring used on each item of equipment and interconnection wiring between items of equipment;

(iii) Maintenance drawings covering each equipment item that contains replaceable parts, appropriately

identifying each part by name and part number; and

(iv) Job drawings including all drawings that are individual to the particular line concentrator involved such as mainframe, power equipment, etc.

(3) The following information shall also be furnished:

(i) A complete index of required drawings;

(ii) An explanation of electrical principles of operation of overall concentrator system;

(iii) A list of tests which can be made with each piece of test equipment furnished and an explanation of the method of making each test;

(iv) A sample of each form recommended for use in keeping records;

(v) The criteria for analyzing results of tests and determining appropriate corrective action;

(vi) A set of general notes on methods of isolating equipment faults to specific printed circuit cards in the equipment;

(vii) A list of typical troubles which might be encountered, together with general indications as to probable location of each trouble; and

(viii) All special line concentrator system grounding requirements.

(4) When installation is to be done by the bidder a complete set of drawings shall be provided by the owner, such as floor plans, lighting, grounding and ac power access.

(q) *Installation and acceptance.—(1) General.* Paragraphs (q)(2)(i) through (q)(3)(xxi) of this section covers the general requirements for the installation of line concentrator equipment by the bidder, and outlines the general conditions to be met by the owner in connection with such installation work. The responsibilities apply in both the central office installation and remote terminal installations, unless otherwise noted.

(2) *Responsibilities of owner.* The owner shall:

(i) Allow the bidder and its employees free access to the premises and facilities at all hours during the progress of the installation;

(ii) Provide access to the remote site and any other site for development work needed during the installation;

(iii) Take such action as necessary to ensure that the premises are dry and free from dust and in such condition as not to be hazardous to the installation personnel or the material to be installed (not required when remote terminal is not installed in a building);

(iv) Provide heat or air conditioning when required and general illumination in rooms in which work is to be performed or materials stored;

(v) Provide suitable openings in buildings to allow material to be placed in position (not required when a remote terminal is not installed in a building);

(vi) Provide the necessary conduit and commercial and dc-ac inverter output power to the locations shown on the approved floor plan drawings;

(vii) Provide 110 volts a.c., 60 Hz commercial power equipped with a secondary arrester and a reasonable number of outlets for test, maintenance and installation equipment;

(viii) Provide suitable openings or channels and ducts for cables and conductors from floor to floor and from room to room;

(ix) Provide suitable ground leads, as designated by the bidder (not required when remote terminal is not installed in a building);

(x) Provide the necessary wiring, central office ground and commercial power service, with a secondary arrester, to the location of an exterior remote terminal installation based on the voltage and load requirements furnished voltage and load requirements furnished by the bidder;

(xi) Test at the owners expense all lines and trunks for continuity, leakage and loop resistance and ensure that all lines and trunks are suitable for operation with the central office and remote terminal equipment specified;

(xii) Make alterations and repairs to buildings necessary for proper installation of material, except to repair damage for which the bidder or its employees are responsible;

(xiii) Connect outside cable pairs on the distributing frame (those connected to protectors);

(xiv) Furnish all line, class of service assignment, and party line assignment information to permit bidder to program the data base memory within a reasonable time prior to final testing;

(xv) Release for the bidder's use, as soon as possible, such portions of the existing plant as are necessary for the proper completion of such tests as require coordination with existing facilities including facilities for T1 span lines with properly installed repeaters between the central office and the remote terminal installations;

(xvi) Make prompt inspections as it deems necessary when notified by the bidder that the equipment, or any part thereof, is ready for acceptance;

(xvii) Provide adequate fire protection apparatus at the remote terminal, including one or more fire extinguishers or fire extinguishing systems of the gaseous type, that has low toxicity and effect on equipment;

(xviii) Provide necessary access ports for cable, if underfloor cabling is selected;

(xix) Install equipment and accessory plant devices mounted external to the central office building and external to the repeater and other outside housings including filters, repeater housings, splicing of repeater cable stubs, externally mounted protective devices and other such accessory devices in accordance with written instructions provided by the bidder; and

(xx) Make all cross connections (at the MDF or Intermediate Distribution Frame IDF) between the physical trunk or carrier equipment and the central office equipment unless otherwise specified in appendix A of this section.

(3) *Responsibilities of bidder.* The bidder shall:

(i) Allow the owner and its representatives access to all parts of the building at all times;

(ii) Obtain the owner's permission before proceeding with any work necessitating cutting into or through any part of the building structure such as girders, beams, concrete or tile floors, partitions or ceilings (does not apply to the installation of lag screws, expansion bolts, and similar devices used for fastening equipment to floors, columns, walls, and ceilings);

(iii) Be responsible for and repair all damage to the building due to carelessness of the bidder's workforce, exercise reasonable care to avoid any damage to the owner's switching equipment or other property, and report to the owner any damage to the building which may exist or may occur during its occupancy of the building;

(iv) Consult with the owner before cutting into or through any part of the building structure in all cases where the fireproofing or moisture proofing may be impaired;

(v) Take necessary steps to ensure that all fire fighting apparatus is accessible at all times and all flammable materials are kept in suitable places outside the building;

(vi) Not use gasoline, benzene, alcohol, naphtha, carbon tetrachloride or turpentine for cleaning any part of the equipment;

(vii) Be responsible for delivering the CO and remote terminal equipment to the sites where they will be needed;

(viii) Install the equipment in accordance with the specifications for the line concentrator;

(ix) Have all leads brought out to terminal blocks on the MDF (or IDF if stated in appendix A of this section) and have all terminal blocks identified and permanently labeled;

(x) Use separate shielded type leads grounded at one end only unless otherwise specified by the owner or bidder or tip cables meeting RUS cable crosstalk requirements for carrier frequencies inside the central office;

(xi) Group the cables to separate carrier frequency, voice frequency, signaling, and power leads;

(xii) Make the necessary power and ground connections (location as shown in appendix A of this section) to the purchaser's power terminals and ground bus unless otherwise stated in appendix A of this section (ground wire shall be 6 AWG unless otherwise stated);

(xiii) Place the battery in service in compliance with the recommendations of the battery manufacturer;

(xiv) Make final charger adjustments using the manufacturer's recommended procedure;

(xv) Run all jumpers, except line and trunk jumpers (those connected to protectors) unless otherwise specified in appendix A of this section;

(xvi) Establish and update all data base memories with subscriber information as supplied by the owner until an agreed turnover time;

(xvii) Give the owner notice of completion of the installation at least one week prior to completion;

(xviii) Permit the owner or its representative to conduct tests and inspections after installation has been completed in order that the owner may be assured the requirements for installation are met;

(xix) Allow access, before turnover, by the owner or its representative, upon request, to the test equipment which is to be turned over as a part of the delivered equipment, to permit the checking of the circuit features which are being tested and to permit the checking of the amount of connected equipment to which the test circuits have access;

(xx) Notify the owner promptly of the completion of work of the central office terminals, remote terminals or such portions thereof as are ready for inspection; and

(xxi) Correct promptly all defects for which the bidder is responsible.

(4) *Information to be furnished by bidder.* The bidder shall accompany its bid with the following information:

(i) Two copies of the equipment list and the traffic calculations from which the quantities in the equipment list are determined;

(ii) Two copies of the traffic tables from which the quantities are determined, if other than the Erlang B traffic tables;

(iii) A block diagram of the line concentrator and associated

maintenance equipment will be provided;

(iv) A prescribed method and criteria for acceptance of the completed line concentrator which will be subject to review;

(v) This special grounding requirements including the recommended configuration, suggested equipment and installation methods to be used to accomplish them;

(vi) The special handling and equipment requirements to avoid damage resulting from the discharge of static electricity (see paragraph (j) (4) (iii) of this section) or mechanical damage during transit installation and testing;

(vii) The location of technical assistance service, its availability and conditions for owner use and charges for the service by the bidder; and

(viii) The identification of the subscriber loop limits available beyond the line concentrator.

(5) *Installation requirements.* (i) All work shall be done in a neat, workmanlike manner. Equipment frames or cabinets shall be correctly located, carefully aligned, anchored, and firmly braced. Cables shall be carefully laid with sufficient radius of curvature and protected at corners and bends to ensure against damage from handling or vibration. Exterior cabinet installations for remote terminals shall be made in a permanent, eye-pleasing manner.

(ii) All multiple and associated wiring shall be continuous, free from crosses, reverses, and grounds and shall be correctly wired at all points.

(iii) An inspection shall be made by the owner or its representatives prior to performing operational and performance tests on the equipment, but after all installing operations which might disturb apparatus adjustments have been completed. The inspection shall be of such character and extent as to disclose with reasonable certainty any unsatisfactory condition of apparatus or equipment. During these inspections, or inspections for apparatus adjustments, or wire connections, or in testing of equipment, a sufficiently detailed examination shall be made throughout the portion of the equipment within which such condition is observed, or is likely to occur, to disclose the full extent of its existence, where any of the following conditions are observed:

(A) Apparatus or equipment units failing to compare in quantity and type to that specified for the installation;

(B) Apparatus or equipment units damaged or incomplete;

(C) Apparatus or equipment affected by rust, corrosion or marred finish; and

(D) Other adverse conditions resulting from failure to meet generally accepted standards of good workmanship.

(6) *Operational tests.* (i) Operational tests shall be performed on all circuits and circuit components to ensure their proper functioning in accordance with appropriate explanation of the operation of the circuit.

(ii) All equipment shall be tested to ensure proper operation with all components connected in all possible combinations and each line shall be tested for proper ring, ring trip and supervision.

(iii) All fuses shall be verified for continuity and correct rating. Alarm indication shall be demonstrated for each equipped fuse position. An already failed fuse compatible with the fuse position may be used.

(iv) Each alarm or signal circuit shall be checked for correct operation.

(v) A sufficient quantity of locally originating and incoming calls shall be made to demonstrate the function of the line concentrator including all equipped transmission paths. When intra-link calling is supplied, all intra-link transmission paths shall be demonstrated.

(7) *Acceptance tests and data required.* (i) Data shall be supplied to the owner by the bidder in writing as a part of the final documents in closing out the contract as follows:

(A) A detailed cross connect drawing of alarm to power board, central office battery to physical trunks or carrier system, wiring options used in terminals, channels, filters, repeaters, etc., marked in the owner's copy of the equipment manual or supplied separately;

(B) The measured central office supply voltages applied to the equipment terminals or repeaters at the time the jack and test point readings are made and ac supply voltages where equipment is powered from commercial ac sources;

(C) A list of all instruments, including accessories, by manufacturer and type number, used to obtain the data; and

(D) The measurements at all jack or test points recommended by the manufacturer, including carrier frequency level measurements at all carrier terminals and repeaters where utilized.

(ii) Data in the form of a checklist or other notations shall be supplied showing the results of the operational tests.

(iii) The bidder shall furnish to the owner a record of the battery cell or multicell unit voltages measured at the completion of the installation of the switching system before it is placed in

commercial service. This is not required at a site where the owner furnishes dc power.

(8) *Joint inspection requirements.* (i) The bidder shall notify the owner in writing at least one week before the date the complete system will be ready for inspection and tests. A joint inspection shall be made by the bidder and the owner (or owner's engineer) to determine that the equipment installation is acceptable. The inspection shall include physical inspection, a review of acceptance test data, operational tests, and sample measurements.

(A) The owner shall review the acceptance test data and compare it to the requirements of this section.

(B) Sample measurements shall be made on all systems installed under this contract. Test methods should follow procedures described in paragraph (g)(5) of this section.

(C) A check shall be made of measured test point and jack readings for compliance with the manufacturer's specifications. This applies also to channels, terminals, carrier frequency repeaters, and fault locating circuits.

(ii) In the event that the measured data or operational tests show that equipment fails to meet the requirements of this section, the deficiencies are to be resolved as set forth in Article II of the 397 Special Equipment Contract. (Copies are available from RUS, room 0174, U.S. Department of Agriculture, Washington, DC 20250-1500.) The reports of the bidder and the owner shall be detailed as to deficiencies, causes, corrective action necessary, corrective action to be taken, completion time, etc.

(The information and recordkeeping requirements of this section have been approved by the Office of Management and Budget (OMB) under the control number 0572-0059.)

**Appendix A to § 1755.397—  
Specification for Line Concentrator  
Detailed Equipment Requirements**

(Information To Be Supplied by Owner)

Telephone Company (Owner)

Name: \_\_\_\_\_

Location: \_\_\_\_\_

Number of LC's Required: \_\_\_\_\_

Line Concentrator Locations:

Location	No. of Lines	Central Office
.....	.....	.....
.....	.....	.....
.....	.....	.....
.....	.....	.....

1. General

1.1 Notwithstanding the bidder's equipment lists, the equipment and materials furnished by the bidder must meet the requirements of paragraphs (a) through (p) of this section, and this appendix A.

1.2 Paragraph (a) through (p) of this section cover the minimum general requirements for line concentrator equipment.

1.3 Paragraph (q) of this section covers the requirements for installation, inspection and testing when such service is included as part of the contract.

1.4 This appendix A covers the technical data for application engineering and detailed equipment requirements insofar as they can be established by the owner. This appendix A shall be filled in by the owner.

1.5 Appendix B of this section covers detailed information on the line concentrator equipment, information on system reliability and traffic capacity as proposed by the bidder. Appendix B of this section is to be filled in by the bidder and must be presented with the bid.

Office Name \_\_\_\_\_  
 (By Location) \_\_\_\_\_  
 LC Designation \_\_\_\_\_

2. Number of Subscriber Lines

	Equipped	Wired only
Single-Party Pay Station (Type: _____) _____	.....	.....
Other (Describe: _____) _____	.....	.....
Total	.....	.....

3. Loop Resistance

3.1 Number of non-pay station lines having a loop resistance, including the telephone set as follows:

3.1.1 For physical trunks between the remote and the office units, the loop resistance is to include the resistance of the trunk.

	No. of lines
1200-1900 ohms	.....
1901-3200 ohms	.....
3201-4500 ohms	.....

3.1.2 Number of pay station lines having a loop resistance, excluding the telephone set, greater than:

	No. of lines
1200 ohms (Prepay)	.....
1000 ohms (Semi-Postpay)	.....

When physical trunks are used, these resistances include that of the facility between the CO and the remote.

3.1.3 Range extension equipment, if required, is to be provided:

By Bidder \_\_\_\_\_  
 By Owner \_\_\_\_\_  
 (Quantity and Type) \_\_\_\_\_

4. Traffic Data

4.1 Average combined originating and terminating hundred call seconds (CCS) per line in the busy hour:

\_\_\_\_\_ CCS/Line. (Assume originating & terminating equal.)

4.2 Percent Intra-Calling \_\_\_\_\_

4.3 Total Busy Hour Calls \_\_\_\_\_

5. TYPE or RINGING

5.1 Frequency No.	1.	2.	3.	4.
Frequency (Hz)	.....	.....	.....	.....
Max. No. of Phones/Freq.	.....	.....	.....	.....

5.2 Minimum ringing generator capacity to be supplied shall be sufficient to serve \_\_\_\_\_ lines (each frequency).

6. Central Office Equipment Interface

6.1 COE will be:

6.1.1 COE Manufacturer \_\_\_\_\_

Type \_\_\_\_\_

Year \_\_\_\_\_

Generic \_\_\_\_\_

6.1.2 See digital central office specification for the switchboard at \_\_\_\_\_

6.2 Interface will be:

6.2.1 Line Circuit(s) \_\_\_\_\_

6.2.2 Direct Digital Interface \_\_\_\_\_

6.2.3 Other (Describe) \_\_\_\_\_

6.3 Mounting rack for line concentrator furnished by:

\_\_\_\_\_ Bidder

\_\_\_\_\_ Owner

(Specify width and height of rack available) (Width) (Height)

6.4 Equipment to be installed in existing building:

\_\_\_\_\_ Yes (Attach detailed plan)

\_\_\_\_\_ No

7. Transmission Facilities

7.1 Transmission facilities between the central office and remote terminals shall be:

7.1.1 Type:

\_\_\_\_\_ VF Carrier Derived Circuits

\_\_\_\_\_ Digital Span Line (DS1)

\_\_\_\_\_ Other \_\_\_\_\_

(Attach a layout of the transmission facilities between the central office and the remote terminals describing transmission and signaling parameters, routing and resistance where applicable.)

7.1.2 Utilizes physical plant

\_\_\_\_\_ Cable Pairs (Existing/New)

\_\_\_\_\_ Other \_\_\_\_\_

**Note:** Unless otherwise stated, physical plant will be supplied by the owner.

7.1.3 Terminal equipment for transmission facility to be supplied by:

\_\_\_\_\_ Owner

\_\_\_\_\_ Bidder

7.1.3.1 Carrier e/w voice terminations \_\_\_\_\_ Yes \_\_\_\_\_ No

Manufacturer and type \_\_\_\_\_  
 Central office voice terminations Equipped \_\_\_\_\_, Wired Only \_\_\_\_\_

7.1.3.2 Digital span line (DS1) supplied by

\_\_\_\_\_ Owner

\_\_\_\_\_ Bidder

Manufacturer and Type \_\_\_\_\_

7.1.3.3 Number of repeaters (per span line) \_\_\_\_\_

7.1.3.4 Diverse (alternate) span line routing required

\_\_\_\_\_ Yes (Describe in Item 11)  
 \_\_\_\_\_ No

7.1.3.5 Span line terminations only \_\_\_\_\_ Yes \_\_\_\_\_ No

7.1.3.6 Span line power required (CO and Remote Terminals) \_\_\_\_\_ Yes \_\_\_\_\_ No

7.1.3.7 Physical facility between CO and remote Loop Resistance \_\_\_\_\_ ohms, Length \_\_\_\_\_ meters

8. Power Equipment Requirements

8.1 Central Office Terminal

8.1.1 Owner-furnished - 48 volt dc power \_\_\_\_\_ Yes \_\_\_\_\_ No

8.1.2 Other (Describe) \_\_\_\_\_

8.1.3 Standby power is available \_\_\_\_\_ Yes \_\_\_\_\_ No

8.2 Remote Terminal

8.2.1 Owner-furnished - 48 vdc power \_\_\_\_\_ Yes \_\_\_\_\_ No

8.2.2 Bidder-furnished power supply \_\_\_\_\_ Yes \_\_\_\_\_ No

8.2.3 AC power available at site: \_\_\_\_\_ 110 vac, 60 Hz, single-phase \_\_\_\_\_ Other (Describe in Item 11)

8.2.4 A battery reserve of \_\_\_\_\_ busy hours shall be provided for this line concentrator terminal when it reaches \_\_\_\_\_ lines at the traffic rates specified.

8.2.5 Batteries supplied shall be:

\_\_\_\_\_ Lead Calcium  
 \_\_\_\_\_ Stabilized Electrolyte  
 \_\_\_\_\_ Sealed Lead Acid

\_\_\_\_\_ Other (Describe in item 11)

8.2.6 Standby power is available \_\_\_\_\_ Yes \_\_\_\_\_ No

9. Remote Terminal

9.1 Mounting

9.1.1 \_\_\_\_\_ Outside Housing (To be furnished by bidder)

9.1.2 \_\_\_\_\_ Concrete Slab to be furnished by owner (Bidder to supply construction details after award.)

9.1.3 \_\_\_\_\_ Manhole, environmentally controlled (Describe in Item 11)

9.1.4 \_\_\_\_\_ Pedestal Mounting

9.1.5 \_\_\_\_\_ Pole Mounting (Owner-furnished installed pole)

9.1.6 \_\_\_\_\_ Prefab Building (Owner-furnished site)

9.2 Equipment is to be installed in an existing building.

\_\_\_\_\_ Yes \_\_\_\_\_ No

(Attach detailed plan.)

9.3 Other (Describe) \_\_\_\_\_  
 \_\_\_\_\_  
 10. Alternates \_\_\_\_\_  
 11. Explanatory Notes \_\_\_\_\_

**Appendix B to § 1755.397—  
 Specification for Line Concentrators  
 Detailed Requirements; Bidder  
 Supplied Information**

Telephone Company (Owner)  
 Name: \_\_\_\_\_  
 Location: \_\_\_\_\_  
 Line Concentrator Equipment Locations  
 Central Office Terminal: \_\_\_\_\_  
 Remote Terminal: \_\_\_\_\_

**1. General**

1.1 The equipment and materials furnished by the bidder must meet the requirements of paragraphs (a) through (p) of this section.

1.2 Paragraph (a) through (p) of this section cover the minimum general requirements for line concentrator equipment.

1.3 Paragraph (q) of this section covers requirements for installation, inspection and testing when such service is included as part of the contract.

1.4 Appendix A of this section covers the technical data for application engineering and detailed equipment requirements insofar as they can be established by the owner. Appendix A of this section is to be filled in by the owner.

1.5 This appendix B covers detailed information on the line concentrator equipment, information as to system reliability and traffic capacity as proposed by the bidder. This appendix B shall be filled in by the bidder and must be presented with the bid.

**2. Performance Objectives**

2.1 Reliability (See paragraph (c) of this section)  
 \_\_\_\_\_  
 \_\_\_\_\_  
 \_\_\_\_\_

2.2 Busy Hour Load Capacity and Traffic Delay (See Paragraph (g) of this section)  
 \_\_\_\_\_  
 \_\_\_\_\_  
 \_\_\_\_\_

**3. Equipment Quantities Dependent on System Design**

3.1 Transmission Facilities between the Central Office and Remote Terminals

Type	Quantity equipped	Quantity wired only
.....	.....	.....
.....	.....	.....
.....	.....	.....

**4. Power Requirements**  
**4.1 Central Office Terminal**  
 Voltage \_\_\_\_\_  
 Current Drain (Amps) Normal \_\_\_\_\_, Peak \_\_\_\_\_  
 Fuse Qty \_\_\_\_\_, Size \_\_\_\_\_, Type \_\_\_\_\_  
 Heat Dissipation (BTU/Hr.) \_\_\_\_\_  
**4.2 Remote Terminal**  
 AC or DC \_\_\_\_\_  
 Voltage \_\_\_\_\_  
 Current Drain (Amps) Normal \_\_\_\_\_, Peak \_\_\_\_\_  
 Fuse Qty \_\_\_\_\_, Size \_\_\_\_\_, Type \_\_\_\_\_  
 Heat Dissipation (BTU/Hr.) \_\_\_\_\_

Power required for heating or cooling equipment in remote bidder-furnished housing  
 \_\_\_\_\_  
 \_\_\_\_\_

**5. Temperature and Humidity Limitations**

**5.1 Temperature**

	Central office	Remote*
Maximum °F (°C) .....	.....	.....
Minimum °F (°C) .....	.....	.....

**5.2 Relative Humidity**

	Central office	Remote*
Maximum .....	.....	.....
Minimum .....	.....	.....

\* Show conditions outside bidder-furnished housing.

**6. Explanatory Notes**

Dated: August 21, 1995.

**Jill Long,**

*Under Secretary, Rural Economic and Community Development.*

[FR Doc. 95-21298 Filed 8-28-95; 8:45 am]

BILLING CODE 3410-15-P

**DEPARTMENT OF TRANSPORTATION**

**Federal Aviation Administration**

**14 CFR Part 25**

[Docket No. NM-109; Special Conditions No. 25-NM-105]

**Special Condition: Gulfstream Aerospace Corporation, Model Gulfstream V, High-Intensity Radiated Fields**

**AGENCY:** Federal Aviation Administration, DOT.

**ACTION:** Final special conditions.

**SUMMARY:** These special conditions are for the Gulfstream Model Gulfstream V airplane. This new airplane will utilize new avionics/electronic systems that provide critical data to the flightcrew. The applicable regulations do not contain adequate or appropriate safety standards for the protection of these systems from the effects of high-intensity radiated fields. These special conditions contain the additional safety standards that the Administrator considers necessary to establish a level of safety equivalent to that established by the existing airworthiness standards. **EFFECTIVE DATE:** September 28, 1995.

**FOR FURTHER INFORMATION CONTACT:** Gerald Lakin, FAA, Standardization Branch, ANM-113, Transport Airplane Directorate, Aircraft Certification Service, 1601 Lind Avenue SW., Renton, Washington 98055-4056, (206) 227-1187.

**SUPPLEMENTARY INFORMATION:**

**Background**

On February 26, 1992, Gulfstream Aerospace Corporation, P.O. Box 2206, Savannah, GA 31402-2206, applied for an amended type certificate in the transport airplane category for the Model Gulfstream V airplane. The Gulfstream V is a T-tail, low swept wing, business jet airplane powered by two Rolls-Royce BR710-48 turbofan engines mounted on pylons extending from the aft fuselage. Each engine will be capable of delivering 14,750 pounds thrust. The flight controls will be powered and capable of manual reversion. The airplane has a seating capacity of up to nineteen passengers, and a maximum takeoff weight of 89,000 pounds.

**Type Certification Basis**

Under the provisions of § 21.101 of the FAR, Gulfstream must show, except as provided in § 25.2, that the Model Gulfstream V meets the applicable provisions of part 25, effective February 1, 1965, as amended by Amendments 25-1 through 25-81. In addition, the proposed certification basis for the Model Gulfstream V includes part 34, effective September 10, 1990, plus any amendments in effect at the time of certification; and part 36, effective December 1, 1969, as amended by Amendment 36-1 through the amendment in effect at the time of certification. No exemptions are anticipated. These special conditions form an additional part of the type certification basis. In addition, the certification basis may include other special conditions that are not relevant to these special conditions.