

HELPING STUDENTS SUCCEED THROUGH THE POWER OF SCHOOL CHOICE

HEARING

BEFORE THE

SUBCOMMITTEE ON EARLY CHILDHOOD,
ELEMENTARY, AND SECONDARY EDUCATION

COMMITTEE ON EDUCATION
AND THE WORKFORCE

U.S. HOUSE OF REPRESENTATIVES

ONE HUNDRED FIFTEENTH CONGRESS

FIRST SESSION

HEARING HELD IN WASHINGTON, DC, FEBRUARY 2, 2017

Serial No. 115-2

Printed for the use of the Committee on Education and the Workforce



Available via the World Wide Web:

www.gpo.gov/fdsys/browse/committee.action?chamber=house&committee=education

or

Committee address: *<http://edworkforce.house.gov>*

U.S. GOVERNMENT PUBLISHING OFFICE

23-827 PDF

WASHINGTON : 2017

For sale by the Superintendent of Documents, U.S. Government Publishing Office
Internet: bookstore.gpo.gov Phone: toll free (866) 512-1800; DC area (202) 512-1800
Fax: (202) 512-2104 Mail: Stop IDCC, Washington, DC 20402-0001

COMMITTEE ON EDUCATION AND THE WORKFORCE

VIRGINIA FOXX, North Carolina, *Chairwoman*

Joe Wilson, South Carolina
Duncan Hunter, California
David P. Roe, Tennessee
Glenn "GT" Thompson, Pennsylvania
Tim Walberg, Michigan
Brett Guthrie, Kentucky
Todd Rokita, Indiana
Lou Barletta, Pennsylvania
Luke Messer, Indiana
Bradley Byrne, Alabama
David Brat, Virginia
Glenn Grothman, Wisconsin
Steve Russell, Oklahoma
Elise Stefanik, New York
Rick W. Allen, Georgia
Jason Lewis, Minnesota
Francis Rooney, Florida
Paul Mitchell, Michigan
Tom Garrett, Jr., Virginia
Lloyd K. Smucker, Pennsylvania
A. Drew Ferguson, IV, Georgia

Robert C. "Bobby" Scott, Virginia
Ranking Member
Susan A. Davis, California
Raúl M. Grijalva, Arizona
Joe Courtney, Connecticut
Marcia L. Fudge, Ohio
Jared Polis, Colorado
Gregorio Kilili Camacho Sablan,
Northern Mariana Islands
Frederica S. Wilson, Florida
Suzanne Bonamici, Oregon
Mark Takano, California
Alma S. Adams, North Carolina
Mark DeSaulnier, California
Donald Norcross, New Jersey
Lisa Blunt Rochester, Delaware
Raja Krishnamoorthi, Illinois
Carol Shea-Porter, New Hampshire
Adriano Espaillat, New York

Brandon Renz, *Staff Director*
Denise Forte, *Minority Staff Director*

SUBCOMMITTEE ON EARLY CHILDHOOD, ELEMENTARY, AND
SECONDARY EDUCATION

TODD ROKITA, Indiana, *Chairman*

Duncan Hunter, California
David P. Roe, Tennessee
Glenn "GT" Thompson, Pennsylvania
Luke Messer, Indiana
David Brat, Virginia
Tom Garrett, Jr., Virginia

Jared Polis, Colorado
Ranking Member
Raúl M. Grijalva, Arizona
Marcia L. Fudge, Ohio
Suzanne Bonamici, Oregon
Susan A. Davis, California
Frederica S. Wilson, Florida

C O N T E N T S

	Page
Hearing held on February 2, 2017	1
Statement of Members:	
Polis, Hon. Jared, Ranking Member, Subcommittee on Early Childhood, Elementary, and Secondary Education	4
Prepared statement of	7
Rokita, Hon. Todd, Chairman, Subcommittee on Early Childhood, Ele- mentary, and Secondary Education	1
Prepared statement of	3
Statement of Witnesses:	
Carter, Ms. Almo J., Parent	15
Prepared statement of	17
Kubacki, Mr. Kevin, Chief Executive Director, The Neighborhood Charter Network	21
Prepared statement of	23
Cherry, Mrs. Nina, Parent	25
Prepared statement of	27
Williams, Mr. Michael L., Manager, Former Commissioner of Education, Texas Education Agency	9
Prepared statement of	11
Additional Submissions:	
Courtney, Hon. Joe, a Representative in Congress from the State of Connecticut:	
Article: Educational Investment That Works And Is Affordable	98
Mr. Polis:	
Letter dated March 30, 2001, from the United States Department of Education	104
Letter dated June 27, 2003, from the United States Department of Education	107
Letter dated July 1, 2003, from the United States Department of Education	110
Letter dated June 27, 2005, from the United States Department of Education	113
Letter dated August 22, 2007, from the United States Department of Education	116
Letter dated August 29, 2007, from the United States Department of Education	118
Chairman Rokita:	
Estimated Charter Public School Enrollment, 2016-17	122
Letter dated November 7, 2012, from the United States Department of Education	127
Letter dated March 30, 2001, from the United States Department of Education	129
Slide: #SchoolChoice by the Numbers	150
Scott, Hon. Robert C. "Bobby", a Representative in Congress from the State of Virginia:	
Letter February 1, 2017, from National PTA	31
Letter February 1, 2017, from National School Boards Association (NSBA)	34
Letter February 1, 2017, from American Federation of Teachers (AFT)	66
Letter February 1, 2017, from Texas Association of School Boards (TASB)	68
Letter February 1, 2017, from National Education Association (NEA)	70

IV

	Page
Additional Submissions—Continued	
Scott, Hon. Robert C. “Bobby”, a Representative in Congress from the State of Virginia—Continued	
Letter February 1, 2017, from National Coalition for Public Education (NCPE)	72
Questions submitted for the record	152
Bonamici, Hon. Suzanne, a Representative in Congress from the State of Oregon to:	
Mr. Kubacki	155
Mr. Williams	157
Response to questions submitted:	
Mrs. Cherry	158
Mr. Kubacki	160
Mr. Williams	162

HELPING STUDENTS SUCCEED THROUGH THE POWER OF SCHOOL CHOICE

**Thursday, February 2, 2017
House of Representatives,
Subcommittee on Early Childhood,
Elementary, and Secondary Education,
Committee on Education and the Workforce,
Washington, D.C.**

The subcommittee met, pursuant to call, at 10:11 a.m., in Room 2175, Rayburn House Office Building, Hon. Todd Rokita [chairman of the subcommittee] presiding.

Present: Representatives Rokita, Roe, Messer, Brat, Garrett, Polis, Grijalva, Fudge, Bonamici, and Davis.

Also Present: Representatives Foxx, Allen, Takano, Adams, Scott, and Courtney.

Staff Present: Courtney Butcher, Director of Member Services and Coalitions; Tyler Hernandez, Deputy Communications Director; Amy Raaf Jones, Director of Education and Human Resources Policy; Nancy Locke, Chief Clerk; Dominique McKay, Deputy Press Secretary; James Mullen, Director of Information Technology; Krisann Pearce, General Counsel; Brandon Renz, Staff Director; Mandy Schaumburg, Education Deputy Director and Senior Counsel; Alissa Strawcutter, Deputy Clerk; Leslie Tatum, Professional Staff Member; Brad Thomas, Senior Education Policy Advisor; Sheariah Yousefi, Legislative Assistant; Tylease Alli, Minority Clerk/Intern and Fellow Coordinator; Austin Barbera, Minority Press Assistant; Jacque Chevalier, Minority Deputy Education Policy Director; Denise Forte, Minority Staff Director; Mishawn Freeman, Minority Staff Assistant; Doug Hodum, Minority Education Policy Fellow; Kimberly Knackstedt, Minority Disability Policy Advisor; and Aneesh Sahni, Minority Education Policy Fellow.

Chairman ROKITA. Good morning. A quorum being present the subcommittee on Early Childhood, Elementary, and Secondary Education will come to order. Welcome to the first hearing of the subcommittee for the 115th Congress. I thank everyone for their cooperation. We are starting a little bit late, only to accommodate the prayer breakfast held today in our Nation's Capital. I also want to extend a special welcome to our new ranking member, my friend, Representative Jared Polis of Colorado. I look forward to working together in the weeks and months ahead. I suspect we will continue to have our differences, but there is no doubt we share the

same goal of helping to ensure every child is prepared to succeed in life. Congratulations and welcome.

Mr. POLIS. Thank you.

Chairman ROKITA. In recent years, this subcommittee has helped advance positive legislative solutions for America's students and families. At the center of those efforts has always been the desire to make sure every child has the opportunity to receive an excellent education. That is a mantra we repeat often around here, and for good reason, it is a critical goal, and it guides much of the work we do in this subcommittee. And it is with that goal in mind that we enacted legislation to put K-12 education back in the hands of those who know best what students need, their parents, and State and local leaders.

We also made significant progress advancing reforms to improve career and technical education, child nutrition assistance, and student privacy. Because there is still a lot of work to do before we reach our shared goal, we will continue working together to deliver the solutions our Nation's children and families deserve and need. We are here today to discuss one of those solutions: school choice.

Across the country, efforts are underway to empower parents with more options when it comes to their children's education. My home State of Indiana, for example, operates a scholarship program to help children from low-income families, children in failing schools, and children with special needs so, that they receive the high-quality education necessary to succeed, both in the classroom and in life. The State also provides tax credits to individuals and employers who donate to nonprofit organizations that award scholarships to these students. And as I am sure our witness, Mr. Kubacki, will explain, Indiana's charter school community has been helping students succeed for years now.

Because these and similar efforts nationwide -- similar efforts nationwide, charter schools are currently serving close to 3 million students, and nearly 400,000 kids are benefiting from a private school choice program, more than ever before, as we can see from the chart above.

While these numbers will help illustrate the growing popularity of school choice, they don't fully capture the hope and opportunity school choice provides, in my opinion. At a committee hearing last year, we heard from a truly inspiring young woman named Denisha Merriweather. Explaining how school choice changed her life, Denisha said, quote, "The cycle of poverty is ending in my family, thanks to the Florida tax credit scholarship. So many opportunities have been given to me, and I want to create the same for other children just like me," end quote.

"The cycle of poverty is ending in my family." Those are pretty powerful words, and Denisha's is a powerful story. Not only did school choice provide her life-changing opportunities, but those opportunities have inspired her to help change the lives of others. Already, the first in her family to graduate from high school and college, Denisha is now working to become the first in her family to receive a graduate degree. She has committed to using that degree to advocate for expanding educational opportunities to other disadvantaged children and families.

Denisha is just one of the countless individuals whose lives have been changed because their families had a choice. With a new Congress and new administration, we now have an opportunity to extend the power of school choice to other families as well. We will look for opportunities to advance school choice and continue our work to improve traditional public schools. But make no mistake, these two efforts do go hand in hand. We will never turn our backs on the millions of students who attend our Nation's public schools, but we also want to ensure parents have the opportunity to choose the best school for their children. And this won't be easy.

In fact, there is already opposition building against the idea of empowering parents with more choices. In many ways, this explains the smear campaign against Betsy DeVos, the President's nominee to serve as Secretary of Education. She has shown her commitment to all children through her words, and more importantly, through her actions. Mrs. DeVos has dedicated her life to helping some of our Nation's most disadvantaged students. Because she stands firmly for parental choice, she is being attacked, maligned across the country.

No one on this committee would ever leave their children trapped in a failing school. I challenge anyone on this committee to say they would. Yet, some would deny other parents their very right to do what is best for their children. If we are serious about improving K-12 education, we have to demand better. The Every Student Succeeds Act is the perfect example of what we can accomplish together when we put the interests of students above politics -- when we focus on policies, not press releases. I remain optimistic that this Congress, we will choose students and advance policies to ensure every child receives an excellent education.

With that, I now recognize Ranking Member Polis.
[The statement of Chairman Rokita follows:]

Prepared Statement of Hon. Todd Rokita, Chairman, Subcommittee on Early Childhood, Elementary, and Secondary Education

Good morning and welcome to the first hearing of the Subcommittee on Early Childhood, Elementary, and Secondary Education for the 115th Congress. Allow me to extend a special welcome to our new ranking member, Representative Jared Polis. I look forward to working together in the weeks and months ahead. I suspect we will continue to have our differences, but there's no doubt we share the same goal of helping to ensure every child is prepared to succeed in life. Congratulations and welcome, Ranking Member Polis.

In recent years, this subcommittee has helped advance positive, legislative solutions for America's students and families. At the center of those efforts has always been the desire to make sure every child has the opportunity to receive an excellent education. That's a mantra we repeat often around here, and for good reason. It's a critical goal, and it guides much of the work we do on this subcommittee.

It is with that goal in mind that we enacted legislation to put K-12 education back in the hands of those who know best what students need—parents and state and local leaders. We also made significant progress advancing reforms to improve career and technical education, child nutrition assistance, and student privacy. Because there is still a lot of work to do before we reach our shared goal, we will continue working together to deliver the solutions our nation's children and families deserve. We're here today to discuss one of those solutions: school choice.

Across the country, efforts are underway to empower parents with more options when it comes to their children's education. My home state of Indiana, for example, operates a scholarship program to help children from low-income families, children in failing schools, or children with special needs receive the high-quality education necessary to succeed both in the classroom and in life. The state also provides tax credits to individuals and employers who donate to nonprofit organizations that

award scholarships to students. And as I'm sure our witness Mr. Kubacki will explain, Indiana's charter school community has been helping students succeed for years.

Because of these and similar efforts nationwide, charter schools are currently serving close to 3 million students, and nearly 400,000 kids are benefitting from a private school choice program – more than ever before. While these numbers help illustrate the growing popularity of school choice, they don't fully capture the hope and opportunity school choice provides.

At a committee hearing last year, we heard from a truly inspiring young woman named Denisha Merriweather. Explaining how school choice changed her life, Denisha said:

“The cycle of poverty is ending in my family, thanks to the Florida Tax Credit Scholarship. Many opportunities have been given to me, and I want to create the same for other children just like me.”

The cycle of poverty is ending in my family. Those are powerful words, and Denisha's is a powerful story. Not only did school choice provide her life-changing opportunities, but those opportunities have inspired her to help change the lives of others. Already the first in her family to graduate from high school and college, Denisha is now working to become the first in her family to receive a graduate degree. She is committed to using that degree to advocate for expanding educational opportunities to other disadvantaged children and families.

Denisha is just one of countless individuals whose lives have been changed because their families had a choice. With a new Congress and a new administration, we now have an opportunity to extend the power of school choice to other families as well. We will look for opportunities to advance school choice and continue our work to improve traditional public schools.

Make no mistake: These two efforts go hand in hand. We will never turn our backs on the millions of students who attend our nation's public schools, but we also want to ensure parents have the opportunity to choose the best school for their children.

It won't be easy. In fact, there is already opposition building against the idea of empowering parents with more choices. In many ways, this explains the smear campaign against Betsy DeVos, the president's nominee to serve as Secretary of Education. She has shown her commitment to all children through her words, and more importantly, through her actions. Mrs. DeVos has dedicated her life to helping some of our nation's most disadvantaged students. Because she stands firmly for parental choice, she is being attacked and maligned across the country.

No one on this committee would ever leave their child trapped in a failing school. No one. Yet, some would deny other parents the right to do what's best for their children. If we are serious about improving K–12 education, we have to demand better. The Every Student Succeeds Act is the perfect example of what we can accomplish when we put the interests of students above politics. When we focus on policies—not press releases. I remain optimistic that this Congress will choose students and advance policies to ensure every child receives an excellent education.

With that, I will now recognize the ranking member, Congressman Polis, for his opening remarks.

Mr. POLIS. I want to thank Chairman Rokita. And in particular, I wanted to thank him for delaying the opening of this committee as we have members, including myself, returning from the prayer breakfast. I know there will be many others joining us that are still on their way back.

I applaud the topic of today's hearing. I am certainly a strong supporter of high quality public school choice. Choice is something that is a fundamental American value in a consumer society: we want to choose our clothes; we want to choose our food; we want to choose our schools to reflect our values and what we value. And before coming to Congress, I have experience in this sector, having founded two public charter schools, one for recent immigrants and English language learners, and another to meet the unique learning needs of homeless and at-risk youth in transitional housing.

Both of those schools, New America School and Academy of Urban Learning, meet the unique needs and challenges of students

meeting them where they are, and provide a chance for them to be able to break the challenges they face, and defy expectations, and succeed and live the American Dream.

I am proud of Colorado. I feel Colorado is an example of public school choice laws that work and how educational opportunities can be a tool for advancing equity and quality in our public education system. An example is Denver public schools, which was named the best large school district for choice in the country by Brookings Institution in 2015. The way Denver works really helps empower parents through a transparent and non-discriminatory enrollment process, meaningful partnerships between charter schools, innovation schools, district schools and strong community support.

We have, among the different types of schools that serve children in this country, district-run public schools, public charter schools and independent schools. Of course, there is no single recipe for success. I can point to schools in any of those categories, public charter schools, district schools, independent schools, that I would do anything to avoid having my child of 5 attend, and I can point to schools in any of those categories, independent, district-run, and charter that I would be proud to send my child to.

So clearly there is no silver bullet. We wish there were, that simply by having every school run by a district or having every school run as a charter, or having every school run independently will somehow make every school excellent. It doesn't work that way. There are different models, there are different advantages and disadvantages to both.

The shortcoming with many of the school choice proposals that are being advanced currently are that they allow independent schools to maintain selective admission requirements. It requires students with disabilities to sign away their rights under the Individual with Disabilities Act, or IDEA, and withhold information from parents regarding student performance.

For a market to work, it really relies on two things: under the laws of economics, it relies on perfect information, or as perfect information as you can have, a/k/a transparency, accountability, and it relies on rational choice. I think everybody would agree that we highly value that parents are always trying to make the best choices for their child. I don't think we doubt that. Where some of the choice proposals are problematic is they don't afford parents in communities the type of relevant information they need in terms of transparency into what is and isn't occurring, particularly on the independent school side. But that is a criticism that frankly, in some areas, has also been valid on the charter school side. I would add, in some areas, it is valid on the district side as well. Parents should be entitled to more information about how schools are doing.

We have examples of programs that work and don't work. In Ohio, which has been noted for having a weak authorizing law for charter schools, there have been a number of instances of schools that have falsified attendance records. In Louisiana, low-quality curriculum and voucher-participating schools have produced bad results for students. In Wisconsin, there has been double-dipping in general education funds that have supported students that were already enrolled in private schools.

So I hope that today's hearing makes clear to the American people that everybody supports and values choice. It's a question around what the parameters of choice are, and what that market, which needs to be designed to benefit students and families first, needs to look like.

In this 1954 ruling in *Brown v. Board of Education*, the Supreme Court affirmed that education is necessary for personal and economic success; saying that "State-funded education is a right that must be made available to all on equal terms." If we are truly committed to fulfilling the promise of *Brown v. Board of Education* for all of our children, regardless of not only race, but income, and ZIP Code, and language status and disability, we need to invest in making sure that schools serve all kids successfully.

I join Chairman Rokita in commending this committee and this Congress in rewriting the Every Student Succeeds Act, ESSA. We look forward to engaging in the oversight of that work through this committee. I have seen, of course, Republicans and Democrats on this committee join with regard to expressing concern for civil rights. But unfortunately, many of us on my side of the aisle, myself included, fear that the Republican school choice proposals are a back door for undermining the civil rights protections that we wrote into ESSA, including those for students with learning disabilities.

Under IDEA, students with disabilities are guaranteed a free and appropriate education. But the private school education programs that exist, where students are sent to independent schools, have no obligation to ESSA, and parents' surveys show that too many private schools require parents to fully or partially sign away their rights under IDEA. I would point that out in contrast to private placement that occurs through school districts with private providers where parents maintain those rights under IDEA.

What we need are school choice programs that empower parents and students with transparency and the information they need and quality choices. Many of the Republican school choice proposals that have been presented before us offer false choices that could only exacerbate educational inequities by requiring that parents sign away their rights, stripping parents of their voice and undermining important civil rights for students.

I wanted to address one final concern I have with school choice programs. As co-chair of the congressional lesbian, gay, bisexual, and transgender equality caucus, I have concerns about the rights of our gay and lesbian students in voucher programs. A 2013 study found that at least 115 private schools that participate in Georgia's voucher program have or promote anti-gay or anti-lesbian admission, scholarship, and discipline policies. Some voucher participating schools in Georgia, and I suspect throughout the Nation, have policies stating that a student can be expelled for identifying as gay or lesbian.

Now our Nation was built on the principle of equality for all Americans, regardless of what people think of the way people choose to live their lives in our free society. Public schools, and that includes schools that are publicly funded, and if independent schools are going to be publicly funded, they would have to play by these rules, cannot discriminate and have to be a safe, welcoming,

learning environment for all students, regardless of those kind of individual issues in their own lives, so their faith, or lack thereof, or their sexual orientation.

Our Nation was built on the principle of equality for all Americans. And it is essential that we empower communities rather than promote policies that treat various Americans as second class citizens.

I look forward to today's hearing from today's witnesses about how we can strengthen our public education system, rather than dismantle it. I thank you and I yield back the balance of my time.

[The statement of Mr. Polis follows:]

Prepared Statement of Hon. Jared Polis, Ranking Member, Subcommittee on Early Childhood, Elementary, and Secondary Education

Thank you, Chairman Rokita, for hosting this morning's hearing on such an important topic. It's no secret that I'm a strong supporter of high-quality public school choice. Before coming to Congress, I founded two public charter schools. One school provides education for recent immigrants and English Language Learners, and another serves homeless and at-risk youth. Both of these schools are meeting the unique needs and challenges of its students, and providing a chance at the great public education that they deserve.

Colorado is an example of how public school choice can be done well, and how it can be a valuable tool for advancing equity in our public school system. That's the school choice I know and the school choice I believe in. A great example is Denver Public Schools, which was named the best large school district for choice in the country by the Brookings Institution in 2015. Denver truly empowers parents through a transparent and non-discriminatory enrollment process, meaningful partnerships between charter and district schools, and strong community support.

Unfortunately, not all public school choice is made equal. In a number of states, weak charter school laws undermine accountability and transparency, and for-profit corporations running charter schools put profits before students.

Republican school choice proposals allow private schools to maintain selective admission requirements, require students with disabilities to sign away their rights under the Individuals with Disabilities Education Act (IDEA), and withhold information from parents regarding their student's performance.

There are numerous examples of the failures of this type of system. In Michigan, 79 percent of charter schools are run by for-profit corporations, and they have some of the worst schools in the nation. In Ohio, a school falsified attendance records to receive additional taxpayer funding. In Louisiana, low-quality curriculum in voucher-participating schools has produced dismal results for students. In Wisconsin, general education funds have been drained – largely to support students already enrolled in private schools. In Georgia, data shows that it is actually upper income families who benefit from the state's voucher program, meaning taxpayers are actually subsidizing private education for the wealthy.

I hope that today's hearing makes clear to the American people that Republican school choice is not the type of choice that will achieve equity of educational opportunity for all children. In its 1954 ruling in *Brown v. Board of Education*, the Supreme Court affirmed that education is necessary for personal and economic success, stating that state-funded education is a right that must be made available to all on equal terms. If we are truly committed to fulfilling the promise of *Brown* for all of our children regardless of zip code, income, race, language status, or disability, we should invest in our public education system instead of siphoning public dollars away from public schools for unaccountable private schools.

Just last year, this Committee worked in a bipartisan fashion to write the Every Student Succeeds Act. Under ESSA, public schools are required to transparently report the performance of vulnerable students and address issues when schools are not appropriately serving these students. I've seen firsthand Republicans' on this committee's concern for civil rights. But unfortunately, Republican school choice is a backdoor to undermining those civil rights protections we wrote into ESSA. Under IDEA, students with disabilities are guaranteed a free and appropriate education. But private school voucher programs have no obligation to ESSA, and parent surveys show that too many private schools require parents to fully or partially sign away their rights under IDEA. I deeply believe that all students with disabilities

deserve the protections and supports to provide them with an equal opportunity at a high-quality education as any other student.

Finally, as co-chair of the Congressional LGBT Equality Caucus, I have deep concerns about the rights of our LGBT students in voucher programs. A 2013 study found that at least 115 private schools participating in Georgia's voucher program have or promote anti-LGBT admission, scholarship, and discipline policies. Some voucher participating schools in Georgia, and I suspect throughout the nation, have policies stating that a student can be expelled for identifying as LGBT or coming out as LGBT. Our nation was built on the principle of equality for all Americans—including racial minorities, individuals with disabilities, and the LGBT community. It is essential that we further empower these communities rather than promote policies that treat them as second-class citizens.

Republican school choice does not empower parents or students; it is a false choice that only further exacerbates educational inequities, strips parents of their voice, and undermines important civil rights protections for parents and students.

I look forward to hearing from today's witnesses about how meaningful choice that supports parents and students can be used to strengthen our system of public education, not dismantle it. Thank you, and I yield back.

Chairman ROKITA. I thank the gentleman.

Pursuant to committee Rule 7(c), all members will be permitted to submit written statements to be included in the permanent hearing record. And without objection, the hearing record will remain open for 14 days to allow such statements and other extraneous material referenced during the hearing to be submitted for the official hearing record.

I will now turn to the introduction of our distinguished witnesses. First we have Mr. Michael Williams. He is a former education commissioner with the Texas Education Agency. Prior to this position, Mr. Williams served as the assistant Secretary of Education for Civil Rights with the U.S. Department of Education under President George H.W. Bush. Currently, Mr. Williams serves as the distinguished leader in residence at the University of North Texas at Dallas. Welcome, sir.

Ms. Almo Carter, a mother living and working in Washington, D.C. Mrs. Carter's son, who has Fragile X Syndrome, attends a D.C. public school and receives services through the Individuals With Disabilities Education Act, IDEA. Ms. Carter served as the former chair of the interagency coordinating council, which is an advisory panel required under the Individuals with Disabilities Education Act. Welcome, Ms. Carter.

Mr. Kevin Kubacki, serves as executive director of the Neighborhood Charter Network, a grassroots organization that manages two public charter schools in Indianapolis, in the great State of Indiana. Enlace Academy and the Kindezi Academy. Prior to this position, Mr. Kubacki served as a school leader with Enlace Academy and as a teacher, coordinator, and coach with the Indianapolis-based schools, Cathedral High School and St. Matthews School. Welcome, sir, I appreciate your leadership.

And finally, Mrs. Nina Cherry is the mother of four children who attend Tampa Bay Christian Academy in Tampa, Florida. Prior to attending Tampa Bay Christian Academy, the Cherry children attended an A-rated public school in Pasco County but had to relocate. In order to provide the best education for their children, Mr. and Mrs. Cherry enrolled them in Tampa Bay Christian Academy with assistance from the Florida tax credit scholarship that I mentioned during my opening remarks. As a result of the excellent edu-

cation received at Tampa Bay Christian Academy, all four of the Cherry children are on the honor roll and excelling. Welcome, ma'am.

I will now ask the witnesses to raise your right-hand.

Seeing their hands raised, do you solemnly swear or affirm that the testimony you are about to give will be the truth, the whole truth and nothing but the truth?

Chairman ROKITA. Please let the record reflect that all witnesses answered in the affirmative.

Before I recognize you to provide your testimony, let me briefly explain our lighting system. It is pretty self-explanatory. And I outline it only in addition for you as a reminder to those of us up here. When you begin, the light in front of you will be green; when 1 minute is left, it will be yellow; and when time has expired, the light will, of course, turn red, at which time you should have wrapped up your remarks. I will hold the members to that same standard, 5 minutes each for their questions.

And we will start with you, Mr. Williams. You are recognized now for 5 minutes for your testimony.

**TESTIMONY OF MICHAEL L. WILLIAMS, FORMER
COMMISSIONER OF EDUCATION, TEXAS EDUCATION AGENCY**

Mr. WILLIAMS. Good morning, Chairman Rokita, Ranking Member Polis, and I see Chairwoman Foxx and members of the committee on Education and the Workforce. Thank you for the opportunity to visit with you today. I am Michael Williams, a lifetime proponent, beneficiary and servant of America's public schools. I am the proud son of two public school teachers. My mother retired after 40 years, and worked as a high school counselor. My father was a math teacher and football and track coach, and retired after 43 years with the honor of being inducted into the Texas High School Coaches Hall of Fame.

I graduated from public schools in Midland, Texas. I'm here to tell you something that has become clear to me during my years of work in education. School choice, including private school choice, is not a threat to strong public schools. Parents are a child's first and most important educators, they are also a child's best advocates. Allowing parents to choose the best education options to meet their child's unique needs is good for our education system, and our schools. But most important, it is good for our children. That is why the education system ought to empower parents to make education choices based on what they know their children need to be successful.

My home State of Texas has the second largest K-12 student enrollment with over 4.29 million students, and has experienced an increase of 1.2 million students over the past 15 years. On most majors, graduation rates, NAEP scores, SAT, ACT scores, AP participation and scores, Texas student performance is on the rise, especially when you compare subpopulations from State to State.

However, deficient student outcomes persist and the academic achievement gap remains extremely stark. Only 49 percent of all white students performed at proficient or above on the NAEP 2013 8th grade reading. Academic outcomes are more dismal for Hispanic and black students, only 20 and 17 percent of whom per-

formed at proficient or above. Texas desperately needs high quality seats for these students. And private school choice could help serve them without significantly impacting public school enrollment.

Despite what you may have heard, private school choice is not at the expense of public school students. In fact, 31 of 33 empirical studies found that choice improved the performance of neighboring traditional public schools. The reality is that choice encourages public schools to be more responsive to students' needs and parent's preferences.

In my work, I have come to understand how truly unique each State's educational landscape is. As commissioner, I work with local school districts to create solutions that fit them best. It became apparent how distant some Federal education policies were from the children served. It is important to strike the right balance between accountability for public dollars and the autonomy essential for private schooling, and that is best accomplished at the State level. Based on my experience as Texas education commissioner, our State's accountability system -- and I would dare say that of other States, would not appropriately fit private school enrolling choice program participants.

Having been responsible for ensuring equal access to education, and the enforcement of civil rights throughout this Nation, I am deeply committed to guaranteeing that all students are treated with respect and dignity, and are free from discrimination in their learning environment.

Currently, public students with special needs who are eligible for services under the Individuals with Disabilities Education Act, have rights to a free and appropriate public education, and individual services among others. The special needs community has fought extremely hard over the decades to guarantee these rights. An American education has certainly come a long way. Some choice programs are targeted at providing students with disabilities, access to high quality educational options. When parents of IDEA-eligible students choose to place their child in a private school with the help of a State-funded choice program, do IDEA rights follow that child?

If an IDEA-eligible student's parents have chosen to place their child in a private school with a choice scholarship, that child is considered a parentally-placed private school student. That student has the same IDEA rights as all other parentally-placed private school students. This is a path parents can choose independent from the school district if a private school's education program better fits the needs of that IDEA-eligible child.

So in conclusion, this is not about private versus public. It is not about -- this is about empowering parents with the ability to choose among high quality, diverse opportunities to fit the unique needs of their children. The vast majority of parents will choose their local public school. Private school choice provides additional high quality options for parents.

Thank you.

[The statement of Mr. Williams follows:]

**House Subcommittee on Early Childhood, Elementary,
and Secondary Education Public Hearing
School Choice and Strong Public Education are Complementary
Mr. Michael L. Williams, former Texas Education Commissioner
February 2nd, 2017**

Good morning and thank you for the opportunity to talk with you today, with special thanks to Subcommittee Chairman Todd Rokita and his team for facilitating this hearing.

I'm Michael L. Williams, a lifetime proponent, beneficiary and servant of America's public schools.

I'm the proud son of two public school teachers. My mother retired after 40 years of service to our public school students, and worked as a high school guidance counselor. My father was a public school math teacher, and retired after 43 years of service with the honor of being inducted in to the Texas High School Football Coach Hall of Fame. I graduated from public school in Midland, Texas.

Relevant to my testimony today, I was honored to serve as the first Black Commissioner of Education in Texas history and leader of the Texas Education Agency—a role I was appointed to by Governor Rick Perry and served from 2012 to 2015. I also served as Assistant Secretary of Education for Civil Rights at the United States Department of Education under President George H. W. Bush.

I'm here to tell you something that has become clear to me during my years of work in education: school choice, including private school choice, is not a threat to strong public schools. Parents are a child's first and most important educators. They are also a child's best advocates. Allowing parents to choose the best education option for the unique needs of their children is good for our education system and our schools. But, most importantly, it's good for children.

Throughout my career in public service, I have been privileged to talk with and learn from hundreds of public school teachers and administrators both in Texas and nationally. The public-school workforce gives so much of themselves to the students they serve, and I am eternally grateful to my colleagues, as well as my parents, for their dedication day-in and day-out. We all want what is best for America's children—parents, teachers, and elected officials alike. That's why our education system ought to empower parents to make education choices based on what they know their children need to be successful.

How Private School Choice Impacts Students:

Texas has the second largest K-12 student enrollment with over 5.2 million students in Fall 2015, only behind California. On top of our large student population, Texas has experienced the

largest K-12 enrollment growth in the nation, with an increase of almost 1.2 million students from 2000 to 2015.ⁱ

On most measures – graduation rates, National Assessment of Educational Progress (NAEP), SAT and ACT scores, Texas student performance is on the rise, especially when you compare subpopulations from state to state.

However, deficient student outcomes persist and the achievement gap remains stark—only 49 percent of all white students were proficient or better on the NAEP 2013 8th Grade Reading. Academic outcomes are more dismal for Hispanic students, who were 20 percent proficient, and Black students, who were 17 percent proficient.ⁱⁱ Texas desperately needs high-quality seats for these students, and private school choice could help serve them without significantly impacting public school enrollment. With rapid, steep and steady enrollment growth and poor academic outcomes, private school choice is a solution needed by Texas and many states like us.

Despite what you may have heard, private school choice is not at the expense of public school students. In fact, of 33 empirical studies examining the impact of school choice on academic outcomes in public schools, one study found no visible effect, one study found a negative effect, and 31 studies found that choice improved the performance of neighboring traditional public schools.ⁱⁱⁱ These outcomes may seem counter-intuitive to some Members of the subcommittee, but the reality is that choice encourages the traditional public school system to be more responsive to students' needs and parents' preferences.

Expectedly, private school choice also improves the academic outcomes of those who participate. Eighteen studies have examined scholarship participants' academic outcomes. Of these, two studies found no visible effect between the students' performance at their former public school and their current private school, two studies found that one program had a negative impact on student performance, and 14 studies found that the program positively improves student outcomes.

Accountability for Private Schools Enrolling Private School Choice Program Participants:

In my work, I have come to understand how truly unique each state's education landscape is. As Commissioner of Education in Texas, I worked with localities to co-create solutions that fit them best. Even in my home state, there is so much local knowledge required to make prudent, focused policy decisions for children. In state-level public education governance, it also became apparent how distant some federal education policies were from the children served. For an example, just look to the No Child Left Behind Act's one-size-fits-all approach to school accountability that, while well intended, quickly became unworkable across all 50 states.

Accordingly, any accountability system for private schools enrolling private school choice program participants should be set at the state level. Appropriate measures must be taken to guarantee the health and safety of students. Financial accountability must ensure that program

funds are being lawfully used. However, oftentimes conversations about accountability boil down to measuring student learning and, specifically, testing requirements. Testing requirements for state private school choice programs range from no testing requirement to requiring the state test—these varied models reflect different political environments and state education systems.

It is important to strike the right balance between accountability for public dollars and the autonomy essential to private schooling. For example, some states require participating private schools administer the private school's choice of state-approved tests, including norm reference tests, and to publicly report on results. This approach provides private schools a choice of what assessment best fits their school model and would best serve their students—which is the whole point of school choice. Although this model has worked well in a number of states, let me again be clear that accountability for private school choice programs should be decided and implemented at the state-level.

Private School Choice and IDEA:

Having been responsible for ensuring equal access to education and the enforcement of civil rights throughout the nation, I am deeply committed to guaranteeing that all students are treated with respect and dignity, and are free from discrimination in their learning environment.

Currently, public students with disabilities who are identified as eligible for services under the Individuals with Disabilities Education Act (IDEA) have IDEA rights—including the right to a Free and Appropriate Public Education (FAPE) in the Least Restrictive Environment (LRE), an Individualized Education Program (IEP), and corresponding individual services. The special needs community has fought extremely hard over the decades to guarantee these rights for students with disabilities. I can remember a time when many students with disabilities didn't even have access to public education, and were forced to remain at home or were institutionalized. To be certain, we've come a long way in special education.

Some private school choice programs are targeted at providing students with disabilities access to high-quality educational options. When parents of IDEA-eligible students choose to place their child in a private school with the help of a state-funded private school choice program, do IDEA rights follow that child into the private school? As Assistant Secretary of Education for Civil Rights, I wrote the first guidance surrounding the application of federal special education rights to Milwaukee's Parental Choice Program—the first private school choice program—with the Assistant Secretary of the Office of Special Education and Rehabilitative Services in 1990. Since that initial guidance, the answer has been clear and consistent throughout Administrations.^{iv}

If a public school district has made FAPE available to an IDEA-eligible student and the student's parents have instead chosen to place their child in a private school with a private school choice scholarship, that child is considered a parentally-placed private school student. That student has the same IDEA rights as all other IDEA-eligible parentally-placed private school student—

they have the right to Child Find services, but have no right to FAPE or individual services as long as they choose to remain in the private school system. Of course, if the parents of an IDEA-eligible child participating in a private school choice program instead decided to return to the public school system, that child would be entitled to FAPE and individual services under IDEA.

Conclusion:

When private school choice is pit against the public-school system, children lose. The conversation we need to be having is one aimed solely at creating high-quality, diverse opportunities to fit the unique needs of children. There is no one best school for every child; however, there is a best school for an individual child. The vast majority of parents are happy with their residential public school and have great respect for public education's role in our democracy. School choice provides additional high-quality options to parents.

ⁱ U.S. Department of Education, National Center for Education Statistics, Common Core of Data (CCD), "State Nonfiscal Survey of Public Elementary/Secondary Education," (December 2013).

https://nces.ed.gov/programs/digest/d13/tables/dt13_203.20.asp

ⁱⁱ U.S. Department of Education, National Center for Education Statistics, National Assessment of Educational Progress (NAEP), "2013 Reading Assessment Report Card: Summary Data Tables with Additional Detail for Average Scores and Achievement Levels for States and Jurisdictions," (2013).

https://www.nationsreportcard.gov/reading_math_2013/files/results_appendix_reading.pdf

ⁱⁱⁱ Friedman Foundation for Educational Choice, "A win-win solution: The empirical evidence on school choice," (2016). <http://www.edchoice.org/wp-content/uploads/2016/05/A-Win-Win-Solution-The-Empirical-Evidence-on-School-Choice.pdf>

^{iv} U.S. Department of Education, Office of Special Education and Rehabilitative Services, "Boswell Letter," (November 7th, 2012). <https://www2.ed.gov/policy/speced/guid/idea/memosdcltrs/12-001767r-fl-boswell-mckayscholarship-11-7-12.pdf>

U.S. Department of Education, Office for Civil Rights and Office of Special Education and Rehabilitative Services, "Bowen Letter," (March 30th, 2001). <https://www2.ed.gov/policy/speced/guid/idea/letters/2001-1/bowen3302001fape.pdf>

Chairman ROKITA. Thank you, Mr. Williams.
Ms. Carter, you are recognized for 5 minutes.

TESTIMONY OF ALMO J. CARTER, PARENT

Ms. CARTER. Thank you. Good morning also, Chairman Rokita, Ranking Member Polis, and Chairwoman Foxx. On behalf of my son, Jacob, I am very pleased to be able to speak here, have this opportunity for not only Jacob, but all children with disabilities. I thank you for this opportunity to speak on the issue of school choice and equitable access to quality education.

My name is Almo Carter, and almost 9 years ago, I brought home from the hospital a baby boy, who I adopted as a single parent. Jacob grew in my heart those 38 weeks before he was born in 2008. And I am thrilled to nurture, raise up, and love him.

With my impending return to work fast approaching, I selected a wonderful child care center. Immediately following placement, I noticed that infants as young as 4 months were meeting developmental milestones that Jacob, who was 7 months at the time, was barely approaching. Over the next 15 months, a series of doctor visits revealed Jacob's underlying diagnosis of Fragile X Syndrome, followed by pervasive developmental disorder, not otherwise specified.

During this time, we were introduced to the Strong Start D.C. Early Intervention Program. I will stop at nothing to ensure that Jacob realizes his full potential, and develops into a productive and positively contributing member of society. Not every parent has this time, nor the ability and wherewithal to do so.

Shortly after we discovered Jacob's disabilities, I placed him at Easter Seals, where Jacob could interact with typically developing peers and receive therapeutic services in accordance with IDEA. Before Jacob turned 3 years old, we started the transition process through early stages. Filled with optimism and encouraged by Jacob's prognosis, I wanted to make sure that he had -- that I knew what those educational opportunities were for him in our community.

I started with our neighborhood public school, and although it had an autism classroom, it was not a placement with which I felt comfortable. I also decided to consider some of the high performing charter schools, and explore their programming for students with disabilities. After attending several charter school open houses, I was not convinced that my school choice options understood and were equipped to appropriately educate Jacob. I ended up applying to a few charter schools through the lottery process, but we were unsuccessful in securing a slot.

With the help of his multidisciplinary team, I placed Jacob in the D.C. public schools' Flagship Autism Program, and he started public school at age 4. After staffing challenges at the school, and changes in Jacob's education requirements as he expanded his capacity to learn, we made an immediate change through his IEP to a general education classroom where it was required he receive specialized instruction, both inside and outside the general education setting.

All schools, whether public, charter, vouchers or virtual, must, in my opinion, comply with the same comprehensive accountability

standards and safeguards in order to be equitable. However, right now, only public schools and public charter schools are held to these accountability standards and safeguards. When evaluating public school choices, it is imperative for families to understand the safeguards and protections of IDEA and they are given consistent information with which to compare and analyze. Each public school choice option should be transparent in communication and held accountable for their responsibility to educate children. A school's number one goal should be the appropriate, effective, and successful education of all students, including those with disabilities.

When a violation of IDEA occurs, parents have recourse under IDEA to activate their due process rights. In my experience, private school choice programs do not provide protections and parental rights akin to those that a public school system has. In most situations, parents of students with disabilities are stripped of their rights when they enter a private school with a voucher, if the private school even accepts the student with a disability in the first place.

Candidly, I perceive the risk of private school choice options to be too great and not worth the possibility of foreclosing Jacob's equitable access to an appropriate quality education. For Jacob -- as a mother, I will continue to advocate on behalf of my son and other students with disabilities to help ensure that they are all afforded equitable access to a quality education.

Thank you for this opportunity.

[The statement of Ms. Carter follows:]

Education and the Workforce
Early Childhood, Elementary and Secondary Education Subcommittee Hearing

Subcommittee Chairman Rokita, Ranking Member Polis, and Members of the Committee on Education and the Workforce:

On behalf of my son Jacob, and all students with disabilities and their families, I thank you for the opportunity to speak on the issue of School Choice and Equitable Access to a Quality Education.

BACKGROUND

My name is Almo J. Carter. Almost 9 years ago I brought home from the hospital a baby boy who I adopted as a single parent. Jacob grew in my heart those 38 weeks before he was born in 2008, and I'm thrilled to nurture, raise-up, and love him! As a new mommy at the time, I took seriously the responsibilities of being a parent and I believed I was prepared intellectually, emotionally and financially to meet the challenges associated with single motherhood.

Fortunately, I was able to spend the first 6 months of Jacob's life at home—enjoying bonding time, cuddling together and watching him grow. With my impending return to work fast approaching, I had to make childcare arrangements for Jacob. Admittedly, I was a little overwhelmed with the options available for childcare as well as the considerations that went into making the 'right and appropriate choice.' In the end, I selected a wonderful childcare center where Jacob was well-cared for and safe.

Immediately following placement, I noticed infants as young as 4 months were meeting developmental milestones that Jacob—at 7 months--was barely approaching. These observations prompted our quest to identify Jacob's developmental deficiencies and delays while learning as much as possible about his biological history. Subsequently, we started working with a cadre of medical specialists, i.e., developmental pediatrics, genetics, neurology, pediatric ophthalmology, urology, etc., as well as child development researchers and professionals. Over the next 15 months a series of doctor visits, assessments, tests, an MRI, and targeted studies revealed Jacob's underlying diagnosis of Fragile X Syndrome (FXS), followed by a Pervasive Developmental Disorder-Not Otherwise Specified (PDD-NOS) diagnosis. During this time we were introduced to the Strong Start DC Early Intervention Program (DCEIP) and through its access to resources and coordination of care Jacob began receiving early intervention services and support. Due to Jacob's disability the panoply of options were limited

The middle child of 3, I've always been a strong believer in fairness and finding common ground in all situations. In fact the tenets of my essence are equity, opportunity and access for all and this applies to Jacob's education as well. Having been entrusted with Jacob's care and well-being, I will stop at nothing to ensure Jacob realizes his full potential and develops into a productive and positively contributing member of society. Driven by my unyielding desire for Jacob's success, along with 25 years of combined professional and personal advocacy, my practice is to investigate and analyze every educational opportunity available to secure Jacob's equitable access to a quality education. Not every parent has the time, ability and wherewithal to

do so where “quality” is measured against the relevant, appropriate, high-quality standards, and effective delivery of instruction.

Shortly after the initial discovery of Jacob’s developmental delays, I placed him at Easter Seals-- a center-oriented childcare facility--where Jacob could regularly interact with typically developing peers and receive the required therapeutic services in accordance with his Individualized Family Service Plan (IFSP) under the Individuals with Disabilities Education Act (IDEA). Before Jacob turned 3 years old we started the transition process to access early childhood education through Early Stages, DC Public Schools. Filled with optimism and encouraged with Jacob’s medical prognosis I was eager to learn the available options for Jacob’s access to a quality education in my community. I started with our neighborhood public school. Although the neighborhood school had an Autism self-contained classroom it was not a placement with which I felt comfortable. I also decided to consider some of the “high-performing” charter schools and explore their programming for students with disabilities.

After attending several charter school open houses, speaking directly with special education staff about services and talking to families already attending, I was not entirely convinced that my school choice options understood and were equipped to appropriately educate Jacob. However, I ended up applying to a few charter schools through the lottery process that I felt were in a position and equipped to serve Jacob’s needs. We were unsuccessful in securing a spot in any of the charter schools we had applied. Consequently, DCPS was our best option and we moved forward through the eligibility and determination process. It is important to note here, similar to my search for daycare, that the panoply of “choice” was narrowed and in fact not a viable choice for Jacob due to his disability.

Following comprehensive research and investigation I zealously advocated for Jacob’s placement in DC Public School’s “flagship” Autism program, which at the time I believed was an appropriate school choice that would afford him equitable access to a quality education. With the help of his multidisciplinary team (MDT) I placed Jacob in the Autism program and he started public school at 4 years of age. Over the next couple of school years the Autism program underwent system-wide changes and experienced a series of unexpected and volatile staffing challenges which negatively impacted Jacob’s academic success in the self-contained classroom. That instability coupled with changes in Jacob’s education requirements as he developed and expanded his capacity to learn prompted an immediate change through his IEP to a general education classroom where it was required he receive specialized instruction both inside and outside the general education setting.

ACCOUNTABILITY AND SAFEGUARDS IN SCHOOL CHOICE FOR EQUITABLE ACCESS TO A QUALITY EDUCATION

All schools whether public, public charter, publically funded vouchers or virtual must, in my opinion, comply with the same uniform, comprehensive accountability standards and safeguards in order to be equitable. However, right now, only public schools and public charter schools are held to the same comprehensive accountability standards and safeguards. Strong accountability measures across school choice options will not only serve to reduce subjectivity, but it will also yield practical and accurate measures of whether equitable access to a quality education has been attained allowing for transparency of the educational system. This allows parents to make informed decisions about choice options.

When evaluating public school choice and equitable access to a quality education it is imperative for families to understand the safeguards and protections of IDEA – namely a free appropriate public education (FAPE) in the least restrictive environment (LRE) and due process protections. This must be coupled with complete, accurate and consistent information with which to compare and analyze. Families and their students with disabilities should, at a minimum consider the availability of specialized instruction and related therapeutic services (OT, PT, speech), service delivery model, i.e., inclusion vs. self-contained, as well as transparency and accountability safeguards, i.e., process, protocol and procedures, etc., across public school choice domains. Each public school choice option should be transparent in communication and school administrators, educators, and staff should all be held accountable for their responsibility to help educate children. A school's number one goal should be the appropriate, effective and successful education of ALL students, including those with disabilities.

Generally, public school systems have an organizational structure and hierarchy of authority that promote transparency and accountability. For the most part, the public school system complies with requirements in IDEA such as a Free and Appropriate Public Education (FAPE) in the Least Restrictive Environment (LRE) and due process protections, and gives regular notice of the parent and student's rights and responsibilities. When a violation of IDEA occurs, parents have recourse under IDEA to activate their due process rights. This ability for recourse is of paramount importance to families and their children. In my experience, private school choice programs do not provide protections and parental rights akin to those that a public school system has. In most situations, parents of students with disabilities are stripped of their rights when they enter a private school with a voucher, if the private school even accepts the student with a disability in the first place.

Candidly, I perceive the risk of private school choice options to be too great and not worth the possibility of foreclosing Jacob's equitable access to an appropriate quality education as mandated and protected by IDEA. In the [DC] public school system recourse opportunities are more readily accessible and include the Executive Office of the Mayor and the City Council as well as the safeguards mentioned earlier under IDEA including due process protections. In my experience for-profit charter schools' organizational culture, attitudes and communicated interests are forces that drive a business model mentality and approach to mass or bulk education. And because it is perhaps perceived to be significantly more costly to appropriately educate students with disabilities, a cost-benefit analysis might reveal a negative effect on their

bottom line. Furthermore, it tends to be even more challenging (and very expensive for families) for traditional private schools to address educational requirements and/or accommodate students with disabilities. Thus, my familiarity, level of comfort and previous success navigating the public school system has benefited Jacob causing us to stay.

INCLUSION IS ESSENTIAL TO EQUITABLE ACCESS TO A QUALITY EDUCATION AND PARAMOUNT TO SUCCESSFUL COMMUNITY INTEGRATION

As Jacob has matured and his needs have changed, inclusive educational opportunities with appropriate educational supports and services are of paramount importance. My research and investigation into non-public special education school programs reveal that meaningful inclusion opportunities are non-existent. Similarly, for-profit and unaccountable charters schools, boast mission-specific programming that doesn't include inclusive opportunities.

A way to increase inclusive practices involves a commitment from individual and collective school leadership to inclusive programming, followed by collaboration and the leveraging of current resources for access to targeted training that will help build and increase capacity to serve greater numbers of students in a meaningful manner. For Jacob equitable access to quality education now includes meaningful inclusion. Research supports meaningful opportunities of inclusion that foster social interaction, learning and engagement between disabled and non-disabled students. Consistent and equitable implementation of an inclusion model is also known to facilitate successful community integration. Thus, my school choice for Jacob remains in the public school system where he has the opportunity to be educated to the greatest extent possible with his general education peers and where I am confident that his educational rights are protected under the IDEA.

In conclusion, Jacob will remain in the public school system. Knowing that my child will be educated with the services, accommodation and protections afforded him by the IDEA in an inclusive environment is paramount. As a mother I will continue to advocate on behalf of my son and other students with disabilities to help ensure that they are ALL afforded equitable access to a quality public education.

Thank you for this opportunity to testify on this critical issue and I look forward to answering your questions.

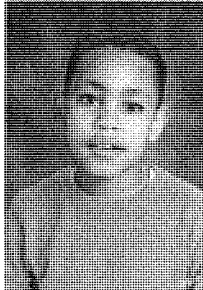

Chairman ROKITA. Thanks, Ms. Carter.
Mr. Kubacki, you are recognized for 5 minutes.

**TESTIMONY OF KEVIN KUBACKI, EXECUTIVE DIRECTOR, THE
NEIGHBORHOOD CHARTER NETWORK**

Mr. KUBACKI. Chairman Rokita, Ranking Member Polis, and members of the subcommittee. My name is Kevin Kubacki, and I am the executive director of the Neighborhood Charter Network in Indianapolis. Thank you for inviting me to discuss how our schools, Enlace Academy and Kindezi Academy, illustrate that school choice can transform the lives of children.

I began this work as a charter school leader because I am, first and foremost, a father. I know what it is like to hold the hand of each one of my three children on the walk on the first day of kindergarten. And I remember vividly hoping that the school would see my children the way I see them. That the school would recognize their individual strengths and truly make them the best versions of themselves. It takes incredible trust for a parent to hand over their most precious creation to a school. And I believe that schools must honor that trust. As a father, I refuse to accept that other parents might not feel the same trust in their own school. With a dedicated talented and diverse board, and equally diverse and talented staff, we launched Enlace Academy in 2013 to give those parents another choice.

Enlace is the founding elementary school for the Neighborhood Charter Network's growing family of public charter schools in Indianapolis that believes that every child can and will learn. The schools located on Indianapolis' west side serving families living in the international marketplace neighborhood were predominantly English language learners.

In order to address the specific needs of each and every one of our students, we use a personalized, blended learning approach paired with intentional character development that is rooted in core values: lead with love, embrace uniqueness, foster character and ignite imagination, so our children can become leaders who choose their own futures in high school, college, and beyond.

Enlace Academy is a grassroots charter school whose name "Enlace" derives from the Spanish word for "link" or "connection," because the school seeks to be the hub of community for her families in creating meaningful connections with community partners, so that our whole families can be healthy and happy. Enlace currently has 365 students, 93 percent of whom are living in poverty. Nearly two-thirds of our students are English language learners, the highest percentage of any school in the State of Indiana.

As a result of our high levels of family engagement and commitment, we have created a stable learning environment for our students with a 90 percent retention rate, and 96 percent attendance rate. Additionally, on the State assessment, our gross score of 115 points far exceeded the State average and earned us an A rating, which only 24 percent of the schools in Indiana received. We have done all of this without having to expel students. We truly believe all children can and will learn.

We are proud of the amazing work our dedicated staff and students who are committed to achieving excellence each and every

day. We also believe that our high student achievement results from rigorous systems of accountability. As a public school, we are held accountable to the State requirements for all schools. As a charter school, we are additionally held accountable to our authorizer for high academic achievement, strong financial health, and ethical governance practices. Most importantly, though, we are held accountable to the families we serve, because ultimately, if we don't honor the trust they place in us, they can choose another school that better meets their needs.

We are excited to be serving families in Indianapolis right now because of the strong school choice legislation that exists, paired with the collective responsibility for the children that is felt by charter schools in Indianapolis public schools, our partner district. Enlace Academy is one of the first charter schools to partner with IPS as an innovation network school. In this symbiotic partnership, we are able to access the economies of scale of the district, and utilize the district facility, and in exchange, we have the autonomy to educate kids in our innovative school model whose State assessment scores are counted for the district.

Furthermore, after seeing success in Enlace Academy, the district extended the partnership by allowing us to implement our successful practices in restarting one of their most academically challenged schools. We launched this in August as our second school, Kindezi Academy. The name Kindezi originates as an African philosophy that preaches taking collective ownership of the education of the children, an apt name given the collaborative educational narrative in Indianapolis today.

While we did receive the charter school's program grant funding when launching Enlace Academy, that option was not available in Indiana when we launched Kindezi. And it is only through the strong partnership we share with IPS that our school's open and profoundly changing lives today.

I am so proud to be managing schools that provide parents with options that can meet the unique needs of their children, and ensure they reach their potential. Parents, not ZIP Codes, get to decide what school meets the specific needs of their children. Charter schools provide parents with options for their child to access a high-quality education.

The charter community now numbers more than 3 million students, and continues to grow as more parents see the power of school choice. I believe offering parents broad school choice helps all students to compete and serve and attract students to their schools.

I thank you for the opportunity to speak to you this morning and look forward to your questions.

[The statement of Mr. Kubacki follows:]



Testimony of Kevin Kubacki

Subcommittee on Early Childhood, Elementary and Secondary Education

February 2, 2017

Chairman Rokita, Ranking Member Polis, and members of the Subcommittee. My name is Kevin Kubacki, and I am the Executive Director of the Neighborhood Charter Network in Indianapolis. Thank you for inviting me to discuss how our schools, Enlace Academy and Kindezi Academy, illustrate that school choice can transform the lives of children.

I began this work as a charter school leader because I am first and foremost a father. I know what it is like to hold the hand of each one of my three children on the walk to school on the first day of Kindergarten, and I remember vividly hoping that the school would see my children the way I see them, that the school would recognize their individual strengths and truly make them the best versions of themselves. It takes incredible trust for a parent to hand over their most precious creation to a school, and I believe that schools must honor that trust. As a father, I refuse to accept that other parents might not feel the same trust in their own school. With a dedicated, talented, and diverse board, and an equally diverse and talented staff, we launched Enlace Academy in 2013 to give those parents another choice.

Enlace is the founding elementary school for The Neighborhood Charter Network's growing family of public, charter schools in Indianapolis that believe that every child can and will learn. The school is located on Indianapolis's west side, serving the families living in the International Marketplace neighborhood who are predominantly English Language Learners. In order to address the specific needs of each and every one of our students, we use a personalized, blended learning approach paired with intentional character development that is rooted in the core values: lead with love, embrace uniqueness, foster character, and ignite imagination so that our children can become leaders who chose their own futures in high school, college, and beyond.

Enlace Academy is a grassroots charter school whose name Enlace derives from the Spanish word for link or connection because the school seeks to be the hub of community for her families and create meaningful connections with community partners so that our whole families can be healthy and happy. Enlace currently has 365 students, 93% of whom are living in poverty. Nearly two-thirds of our students are English Language Learners, the highest percentage of any school in the state of Indiana. As a result of our high levels of family engagement and commitment, we have created a stable learning environment for our students, with a 90% retention rate and 96% attendance rate. Additionally, on the state assessment, our growth score of 115 points far exceeded the state average and earned us an A-rating, which



only 24% of the schools in Indiana received. We have done all of this without having to expel students. We truly believe all children can and will learn.

We are proud of the amazing work of our dedicated staff and students who are committed to achieving excellence each and every day. We also believe that our high student achievement results from rigorous systems of accountability. As a public school, we are held accountable to the state requirements for all schools. As a charter school, we are additionally held accountable to our authorizer for high academic achievement, strong financial health, and ethical governance practices. Most importantly, though, we are held accountable to the families we serve because, ultimately, if we don't honor the trust they place in us, they can choose a school that better meets their needs.

We are excited to be serving families in Indianapolis right now because of the strong school choice legislation that exists paired with the collective responsibility for the children that is felt by charter schools and Indianapolis Public Schools, our partner district. Enlace Academy was one of the first charter schools to partner with IPS as an Innovation Network school. In this symbiotic partnership, we are able to access the economies of scale of the district and utilize a district facility and, in exchange, we have the autonomy to educate kids in our innovative school model whose state assessment scores are counted for the district.

Furthermore, after seeing success at Enlace Academy, the district extended the partnership by allowing us to implement our successful practices in restarting one of their most academically challenged schools. We launched this school in August as our second school, Kindezi Academy. The name Kindezi originates as an African philosophy that preaches taking collective ownership of the education of the children, an apt name given the collaborative educational narrative in Indianapolis today. While we did receive the Charter Schools Program Grant funding when launching Enlace Academy, that option was not available in Indiana when we launched Kindezi Academy, and it is only through the strong partnership we share with IPS that our school is opened and profoundly changing lives today.

I am so proud to be managing schools that provide parents with options that can help meet the unique needs of their children and ensure that they reach their potential. Parents, not zip codes get to decide what school meets the specific needs of their children. Charter schools provide parents with options for their child to access a high quality education. The charter community now numbers more than 3 million students, and continues to grow, as more parents see the power of school choice. I believe offering parents broad school choice helps all students, as schools compete to serve and attract students to their schools.

I thank you for the opportunity to speak to you this morning and I look forward to your questions.

Chairman ROKITA. Thank you, sir.
Mrs. Cherry, you're recognized for 5 minutes.

TESTIMONY OF NINA CHERRY, PARENT

Mrs. CHERRY. Good morning, Chairman Rokita, Ranking Member Polis, and Chairwoman Foxx, and distinguished members of the subcommittee. It is an honor to be here to share my family's school choice story with you. My name is Nina Cherry. I live with my husband, Demetrius, and our four children in Tampa, Florida. School choice provided my family with the hope and stability my children badly needed. And from the school choice community, we were welcomed into, I know my family's story is not all that unique. For parents, it is not about public school versus private schools. We are just looking for schools that meet our children's needs.

My children were thriving in a wonderful A-rated Pasco County public school. When my husband's sales commission plummeted, we lost our permanent home. Without our home, our children were no longer zoned for the public school where they learned and thrived. It was an extremely difficult time for us. We spent several months couch-surfing as a family of six, staying with friends and family until my husband can find a new job. As we bounced from school zone to school zone, I decided that I didn't want my children's education to suffer because of our family's economic struggles.

I heard about Florida's tax credit scholarship program from a friend, and I immediately applied. I was so relieved and beyond thrilled when my children were granted the scholarship. I began looking into some of Florida's 1,700 private schools that enroll tax credit scholarship students. When I toured Tampa Bay Christian Academy, I knew everything was going to be okay. The scholarship provided by Florida's program enables us to send all four of our children to Tampa Bay Christian Academy. During that dark time, I was so grateful that Demetrius and I could concentrate on getting back on our feet, knowing that we found a school that meets our children's needs, educationally.

Florida's tax credit scholarship program was a lifeline for our family, and I am so thankful we live in a State that provides school choice. Our entire family has felt welcome by the school choice community and our school. Tampa Bay Christian provides the family environment I wanted for my children, especially during this hard time.

Since my children enrolled in Tampa Bay Christian Academy, I have joined the school staff as the administrative assistant. I also serve as a senior class adviser and mentor older girls at the school. With my employee discount, we pay some tuition for each child, but the scholarship makes educating our children in the environment that works best for them possible. But the scholarship makes educating our children and the environment that works best for my children's needs. Our children are thriving at Tampa Bay Christian, and all four of them are on honor roll. Some people who don't really understand school choice programs claim they don't have enough accountability.

For my children's education the primary accountability rests with Demetrius and me. If we don't feel that the school is serving

our kids well, we are empowered to communicate our concerns to the school. If we decide another school would meet our children needs better, we can move them to that school.

In Florida, the tax credit scholarship follows a child, even if the child transfers during the school year. One of the reasons we chose Tampa Bay Christian Academy is because it holds my kids to a high expectation, and there is a culture of high achievement. Also, Florida tax credit scholarship students have to take an annual test. At Tampa Bay Christian Academy, my children are assessed annually in math and reading. And the teachers can use the test results to help my kids learn more throughout the year.

I know my school choice story is not unique. There are over 97,000 students using Florida's tax credit scholarships this school year. There are over 400,000 students nationwide benefiting from private school choice programs, plus millions of students benefiting from charter schools, magnet programs, and open enrollment.

I am very supportive of providing a wide range of options for families. Children vary in so many ways. Family situations change, and students' academic and emotional needs can change as well. School choice programs, like the Florida tax credit scholarship program, allow parents to find the environment where the children will learn best.

Chairman Rokita, Ranking Member Polis, and distinguished members of the subcommittee, I want to thank you once again for holding this hearing and communicating to families across the country that you are committed to expanding their educational opportunities. I hope that sharing my story here will help make an impact on other families.

[The statement of Mrs. Cherry follows:]

Statement before the United States Congress
House Committee on Education and the Workforce's
Subcommittee on Early Childhood, Elementary, and Secondary Education
"Helping Students Succeed Through the Power of School Choice"
Nina Cherry
February 2, 2017

Good morning, Chairman Rokita, Ranking Member Polis, and distinguished members of the Subcommittee. It is an honor to be here to share my family's school choice story with you.

My name is Nina Cherry. I live with my husband, Demetrius, and our four children in Tampa, Florida.

School choice provided my family with the hope and stability my children badly needed. And, from the school choice community we've been welcomed in to, I know my family's story is not all that unique. For parents, it's not about public schools versus private schools. We are just looking for schools that meet our children's needs.

My children were thriving in wonderful, A-rated Pasco County public schools, but when my husband's sales commission plummeted, we lost our permanent home. Without our home, our children were no longer zoned for the public school where they learned and thrived.

It was an extremely difficult time for us. We spent several months couch-surfing as a family of six, staying with friends and family until my husband could find a new job. As we bounced from school zone to school zone, I decided that I didn't want my children's education to suffer because of our family's economic struggles.

I heard about Florida's tax-credit scholarship program from a friend and immediately applied. I was so relieved, and beyond thrilled, when my children were granted scholarships. I began looking into some of Florida's 1,700 private schools that enroll tax-credit scholarship students. When I toured Tampa Bay Christian Academy, I knew everything was going to be okay. The scholarships provided by Florida's program enables us to send all four of our children to Tampa Bay Christian.

During that dark time, I was so grateful that Demetrius and I could concentrate on getting back on our feet knowing we found a school that would best meet our children's educational needs. Florida's tax-credit scholarship program was a lifeline for our family, and I am so thankful we live in a state with school choice programs.

Our entire family has felt welcomed by the school choice community, and our school. Tampa Bay Christian provides the family environment I wanted for my children, especially during this hardship.

Since my children enrolled in Tampa Bay Christian, I have joined the school's staff as the Administrative Assistant. I also serve as the Senior Class Advisor and mentor older girls at the school. With my employee discount, we pay some tuition for each child, but the scholarship makes educating our children in the environment that works best for them possible. Our children are thriving at Tampa Bay Christian, and all four of them are on the honor roll.

Some people who don't really understand school choice programs claim that they don't have enough accountability. For my children's education, the primary accountability rests with Demetrius and me. If we don't feel that the school is serving our kids well, we are empowered to communicate our concerns to the school. If we decide another school would meet our children's needs better, we can move them to that school. In Florida, the tax-credit scholarship follows the child even if the child transfers during the school year.

One of the reasons we chose Tampa Bay Christian is because it holds my kids to high expectations and there is a culture of high achievement. Also, Florida tax-credit scholarship students have to take an annual test. At Tampa Bay Christian, my children are assessed annually in math and reading, and the teachers can use the test results to help my kids learn more throughout the year.

I know my school choice story is not unique. There are over 97,000 students using Florida tax-credit scholarships this school year. There are over 400,000 students nationwide benefiting from private school choice programs, plus millions of students benefiting from charter schools, magnet programs and open enrollment.

I am very supportive of providing a wide range of options to families. Children vary in so many ways. Families' situations change and students' academic and emotional needs can change, as well. School choice programs like the Florida tax-credit scholarship program allow parents to find the environment where their children will learn best.

Chairman Rokita, Ranking Member Polis, and distinguished members of the Subcommittee, I want to thank you once again for holding this hearing and communicating to families across the country that you are committed to expanding their educational opportunities. I hope that sharing my story here will help make an impact on other families.

Chairman ROKITA. Thank you, Mrs. Cherry.

We will now entertain member questionings. In the interest of accommodating as many members as possible in their schedules, I am going to go last in my questioning.

With that, I will recognize the chairwoman of the full committee, Dr. Foxx, for 5 minutes.

Chairwoman Foxx. Thank you, Chairman Rokita, and I want to thank all of our witnesses for being here today. I noted such good time management on your part, too.

Mr. Williams, not everyone knows this, but my first experience in public office was on my local school board, and I went to public schools. I served for 12 years on the local school board. It is always frustrating to me that advocates for public education see parental choice across the full range of available educational options as such a threat. It seems to me that those of us who support greater educational choice need to do a better job of explaining our support. We do not oppose public education. Your experience makes it clear you do not oppose public education. So how can proponents of school choice make it clear that support for giving parents more options to find the right school for their children does not arise from opposition to public education?

Mr. WILLIAMS. Madam Chairwoman, I think what we have to do fundamentally is to have a conversation with the American people about the value of learning and that parents are entitled to make a decision that they believe is in the best interest of their children. Children have different interests, children have different learning styles. Some parents may want a youngster to be imbued with a certain kind of, perhaps, a religious experience during their learning. And what you are trying to do is match the student with the proper learning environment to be able to make sure that youngster can succeed in life. And so, public school -- there is a great value to public school, I was a State commissioner. But there is also an opportunity and a value for a private learning experience as well.

Chairwoman Foxx. Thank you.

Mr. Kubacki, you state in your testimony that your schools have accountability to States, your authorizer, and most importantly, to parents. Can you expound on why the accountability to parents is the most important aspect of the accountability your schools face? And what does that accountability look like?

Mr. KUBACKI. Absolutely. We invite the parents to be part of our team for educating the child. It goes back to the proverb of "it takes a village" to educate children. And so what we do is we put a lot of work in the front end before we open the school, and then continually, as the school is in session, to continually invite the parents in. We have monthly family events where families can come in and see what has been going on in the school. Parents are invited to -- we have an open door policy where they are invited to come to the classrooms. We connect with the parents to make sure they have a clear understanding of the progress of their students, both educationally and in their character development. And we see them just as our partners. And we know that if we are not serving to meet the needs of the parents, that they are going to find a school that does meet those needs. And so for us, we pay

very special attention to what are the unique needs for all of the families. And as the name Enlace suggests, we will also try to connect those parents to services that they may be able to utilize to help make sure that the home environment is stable so that the children can come to school ready to learn.

Chairwoman Foxx. Thank you very much.

Mrs. Cherry, you said in your testimony that the primary accountability rests with you and your husband, Demetrius. You are empowered to find the school that best meets your children's needs. What reaction do you have when you hear the arguments that parents can't be trusted to make the right decision for their children?

Mrs. CHERRY. Thank you for the question. I don't believe that's true at all. As a parent, we know our children better than anybody. We know what needs they have. We know the different unique learning styles they have. So it kind of saddens me that there's people that think that parents don't know what's best for their child. Because for me and my husband, we do know what's best for our children.

Chairwoman Foxx. Thank you, very much. And Ms. Carter, I want to say to you thank you so much for being willing to adopt your child. I think anyone who adopts a child is to be commended, and certainly what you have done to be an advocate is to be commended.

Thank you, Mr. Chairman. I yield back.

Chairman ROKITA. I thank the chairwoman. The ranking member is going to employ a bit of the same model that I have on my side so with that, I would recognize the ranking member of the full committee, Mr. Bobby Scott --

Mr. SCOTT. Thank you, Mr. Chairman.

Chairman ROKITA. -- for 5 minutes.

Mr. SCOTT. Thank you, Mr. Chairman. First, I would like to submit six documents for the record, letters opposing the harmful Republican school choice proposals from the National PTA, the National School Boards Association, American Federation of Teachers, Texas Association of School Boards, National Education Association, and finally, a letter signed by 50 national organizations, including disability advocacy organizations and civil rights organizations, all opposing private school vouchers.

Chairman ROKITA. Without objection.

[The information follows:]



February 1, 2017

The Honorable Virginia Foxx
Chairwoman
Committee on Education and the Workforce
U.S. House of Representatives
2176 Rayburn House Office Building
Washington DC 20515

The Honorable Bobby Scott
Ranking Member
Committee on Education and the Workforce
U.S. House of Representatives
2101 Rayburn House Office Building
Washington, DC 20515

Dear Chairwoman Foxx, Ranking Member Scott and Members of the Committee on Education and the Workforce:

On behalf of National PTA and our 4 million PTA members, we appreciate the opportunity to submit this letter in advance of the Committee's hearing on "Helping Students Succeed Through the Power of School Choice," scheduled for Feb. 2, 2017. National PTA is the oldest and largest volunteer child advocacy association in the United States, with congresses in all 50 states, DC, Virgin Islands, Puerto Rico and Europe. For over 120 years, National PTA has been a strong advocate for public education and a reputable resource for empowering all families to effectively engage in their child's education.

Our association remains steadfast in our approach of putting the needs of all children first by advocating for high-quality public education. National PTA supports public education as the major vehicle for preserving the basic values of a democratic system of government. This system must be strengthened with the support of adequate funding, and continue to be governed by public officials.

National PTA supports educational choices within public schools so as to meet the needs of all students and believes parents and families should be involved in the planning, development, implementation and evaluation of public school choice plans. In addition, National PTA believes public school choice programs—special programs within a school, intra or inter-district choice, magnet or regional schools—should adhere to the following principles:

- Schools must provide adequate, objective and language-appropriate information to parents so they can make informed decisions
- Students must have access to free transportation to ensure equity
- Schools must offer a fair and open selection process
- Curriculum, personnel and student performance standards must be non-discriminatory and assure equal educational opportunities
- Public funds must be used for public schools only



However, there is a difference between public school choice programs and the use of taxpayer dollars for private school voucher programs. **National PTA opposes any private school choice proposal and/or voucher system that diverts public funds to private or sectarian schools.** Public dollars carry the responsibility for providing public access, governance and accountability. National PTA believes that public support of any school must not be allowed to detract or divert money from the continued operation of a viable system of public education.

We will oppose any attempt to funnel taxpayer funds to a private school voucher program such as—vouchers, tax credits, deductions or a portability scheme—that would divert public school resources. Vouchers divert desperately-needed resources away from the public school system to fund the education of a few, select students, with limited, if any, real impact on student academic achievement. Instead of providing equal access to high-quality education or setting high standards for accountability, voucher programs have proven ineffective, lack accountability to taxpayers and deprive students of rights. Congress would better serve all children by using funds to make public schools stronger and safer, rather than by creating a new voucher program.

Although promoted as “school choice,” private school vouchers do not provide real choice for students and parents. In fact, calling vouchers “school choice” is a misnomer, as they do not provide quality education choices to most families. Studies show that voucher programs often fail to provide adequate, objective and language-appropriate information to families in order to allow them to make an important and critical decision for their child. This is particularly troubling to us at National PTA. The “choice” in voucher programs actually lies with private schools, which may turn students away for a variety of reasons. In contrast, public schools are open to all.

Students with disabilities are particularly underserved by voucher programs. Private voucher schools do not adequately serve students with disabilities, often denying them admission or subjecting them to inappropriate or excessive suspensions or expulsions. Nor do private voucher schools provide them with the same quality and quantity of services available to students in public schools, including those mandated under each student’s individualized education plan (IEP). For example, in Washington, DC, a significant number of students who received a private school voucher had to reject their vouchers because they were unable to find a participating school that offered services for their learning or physical disability or other special needs.

Vouchers also fail to improve academic opportunities. Recent studies of the Louisiana and Ohio voucher programs revealed that students who used vouchers actually performed worse on standardized tests than their peers who were not in the voucher programs. Multiple studies of the DC, Milwaukee and Cleveland school voucher programs revealed similar findings: students who were offered vouchers did not perform better in reading and math than students in public schools. In fact, Department of Education studies of the DC voucher program show that students who participated in the program were actually less likely to have access to ESL programs, learning



support and special needs programs, tutors, counselors, cafeterias and nurse's offices than students not in the program.

Moreover, voucher programs offer little accountability to taxpayers. Private school voucher programs usually do not require participating private schools to comply with the same teacher standards, curriculum, reporting and testing requirements as public schools. And private schools that receive voucher students do not adhere to all federal civil rights laws, religious freedom protections provided under the First Amendment of the U.S. Constitution and public accountability standards that all public schools must meet, including those in Title IX, the Individuals with Disabilities Education Act (IDEA) and the Every Student Succeeds Act (ESSA).

Finally, vouchers violate religious liberty by funding primarily religious schools. One of the most dearly held principles of religious liberty is that government should not compel any citizen to furnish funds in support of a religion with which they agree or disagree. Voucher programs, however, violate that central tenet: they use taxpayer money to fund primarily religious education. Parents and families certainly may choose such an education for their children, but no taxpayer should be required to pay for another's religious education.

For these reasons and more, we oppose private school vouchers. Congress must ensure that public dollars remain invested in public schools for the benefit of all students.

We appreciate the opportunity to share our views on public school choice and vouchers. If you would like additional information regarding National PTA's positions on these issues, please contact Jacki Ball, director of government affairs at (703) 518-1243 or JBall@PTA.org.

Sincerely,

Laura M. Bay
President
National PTA

Nathan R. Monell, CAE
Executive Director
National PTA





www.nsba.org
 Phone: 703.838.NSBA Fax: 703.683.7590
 1680 Duke Street Alexandria, Virginia 22314-3493

February 1, 2017

The Honorable Todd Rokita
 Chairman
 Subcommittee on Early Childhood,
 Elementary and Secondary Education
 Committee on Education and the Workforce
 U.S. House of Representatives
 Washington, DC 20515

The Honorable Jared Polis
 Ranking Member
 Subcommittee on Early Childhood, Elementary and
 Secondary Education
 Committee on Education and the Workforce
 U.S. House of Representatives
 Washington, DC 20515

Re: *"Helping Students Succeed Through the Power of School Choice" Subcommittee Hearing*

Dear Chairman Rokita and Ranking Member Polis:

The National School Boards Association (NSBA), representing more than 90,000 local school board members across the nation, working with and through our state associations, is writing to acknowledge this week's Subcommittee hearing that seeks to examine school choice and discuss how federal policies can support such efforts.

As you explore school choice throughout our communities, we urge you to examine the existing range of choices that are currently offered by our nation's public school districts, which educate more than fifty million students. From local magnet schools and charter schools authorized by local school boards to public specialty schools, such as military academies and those offering specialized curricula for science, technology, engineering and mathematics (STEM), many of our public school districts provide several options for the success of our students. Please reference the examples included in this correspondence.

We urge both Congress and the Administration to encourage and advance a balanced dialogue on evidence-based choice options to help inform our nation's efforts to assure every child is prepared for college, careers and citizenship. Likewise, we urge efforts to "level the playing field" so that all schools that receive public funds are held to the same accountability standards and can be appropriately compared. NSBA supports local community public schools and unconditionally opposes vouchers, tuition tax credits and similar initiatives, including charter schools not approved by local school boards. Further, NSBA urges full accountability of the use of public funds for any educational purpose and believes that public funds should be used within public schools to advance curricula and choice, including charter schools authorized by local school boards.

This January, NSBA's Center for Public Education reexamined findings regarding the effectiveness of educational choice in a report titled "[School Choice: What the Research Says](#)." The report findings indicate the following:

- *There's no reason to conclude that choice in itself will produce better outcomes.* While many schools of choice do an exemplary job, the results aren't universally better than those produced by traditional public schools.
- *Non-public school choice should come with warning labels.* Policymakers who are considering supporting parents who wish to choose private schools or homeschooling should be aware that very little is known about the overall efficacy of schooling outside of public schools.
- *Expanding charter schools is not an overall reform strategy.* Most charter schools are no better than their traditional public school counterparts. Merely having more of them will not raise performance. Rather, policymakers and educators should focus on learning from successful charter schools about policies and practices that can help improve all schools.

In general, the Center's report found that school choices work for some students sometimes, are worse for some students sometimes, and are usually no better or worse than traditional public schools. We hope that this report will inform the ongoing conversation about the efficacy of school choice in the nation's efforts to assure every child is prepared for college, careers and citizenship.

REALITY CHECK

After more than two decades of choice policies, enrollments in schools of choice are still relatively small. **87% of all school-aged children are in public schools.**

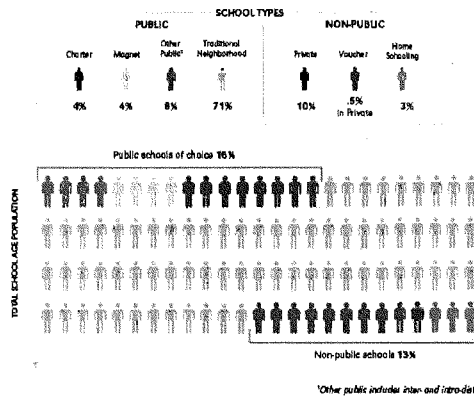

The numerous options for educational choice provided by our public school districts promote success in student achievement and school performance, and are impactful in equipping our students for college and careers. The attached examples of effective public school choice are indicative of how vital our public school districts are to their respective communities, economies and the nation in expanding opportunities for our students, as future leaders and practitioners in numerous sectors.

NSBA appreciates this opportunity to highlight the successful and diverse programs of study offered by many of our public school districts, which help advance both equity and excellence and support our school boards in their efforts to provide the high-quality public education that all children deserve and need to be productive citizens. Likewise, we look forward to working you throughout the 115th Congress to ensure the success of America's public schools.

Sincerely,

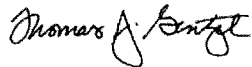

Thomas J. Gentzel
Chief Executive Officer and Executive Director

cc: The Honorable Virginia Foxx, Committee Chair
The Honorable Robert C. "Bobby" Scott, Ranking Member

Attachments:

- Examples of educational choice provided by our public school districts
- "*School Choice: What the Research Says*," Center for Public Education, National School Boards Association, January 2017
- "Deeper Learning: A Georgia School Teaches Skills that Translate to the Workplace," *American School Board Journal*, December 2016

Examples of Educational Choice within Public School Districts

Denver Public Schools is a prime example of a school choice district. Denver allows all families to apply for a school-of-choice within the district. While only about two-thirds of families completed a choice application, of those who did, 86% of kindergarteners, 80% of 6th graders, and 87% of 9th graders received their first choice. Parents receive information regarding each school's performance and special program offerings, which include Montessori, International Baccalaureate, science focus, arts focus, dual-language, expeditionary learning, and international focus schools. While all of the 200 schools are accountable to the Denver Public Schools Board of Education, some are independently operated by charter school management and others are "innovation schools," which have freedom from some state and district regulations. Additionally, some students from outside of DPS's boundaries enroll in DPS schools, while some Denver students opt to attend schools in other districts.

Large urban schools are not the only types of districts offering increased flexibility to their families. **Grand Prairie Independent School District**, outside of Dallas, TX, is an "open enrollment" districts that serves 29,000 students. The district offers 19 traditional schools and 22 "schools of choice" that offer specialized programs including arts, leadership, STEM, languages, college prep, and career technical education. The default choice for families is their neighborhood school, but they may apply to attend any traditional or choice school in the district. Families from outside the district may also apply to attend GPISD schools if they meet certain academic criteria.

Some states also support **inter-district choice**. Forty-six states offer some form of inter-district transfer policies, with some states requiring districts to offer transfers and others allowing voluntary participation by school districts.

New Jersey offers inter-district transfer to students. The state has a website with clear information for families regarding which districts allow transfers, which grades they serve, how many seats are available in each grade, and district performance. As of 2015, about 5,000 students transferred into 136 different school districts. The state portion of school funding, about \$10,500, transfers with the student to the new district, while the "home" district of the student pays for some transportation costs but otherwise keeps the local allocation of funds for that student.

Other state choice options include specialty schools, such as the **Oklahoma School of Science and Mathematics** (OSSM), which is a public 2-year residential high school for students who are academically gifted in science and mathematics. The highly selective school is paid for by the state legislature and any Oklahoma resident entering their junior year of high school may apply.

Video: **Delaware's William Penn High School** principal talks about his public school's approach to college-career readiness that provides every student a career focused experience. In the four years of the program, enrollments, graduation and college-going rates have gone up, and dropout rates have gone down. Interestingly, this innovative program was developed by the existing staff:
https://www.youtube.com/watch?v=5MOzBvQ_rAw.

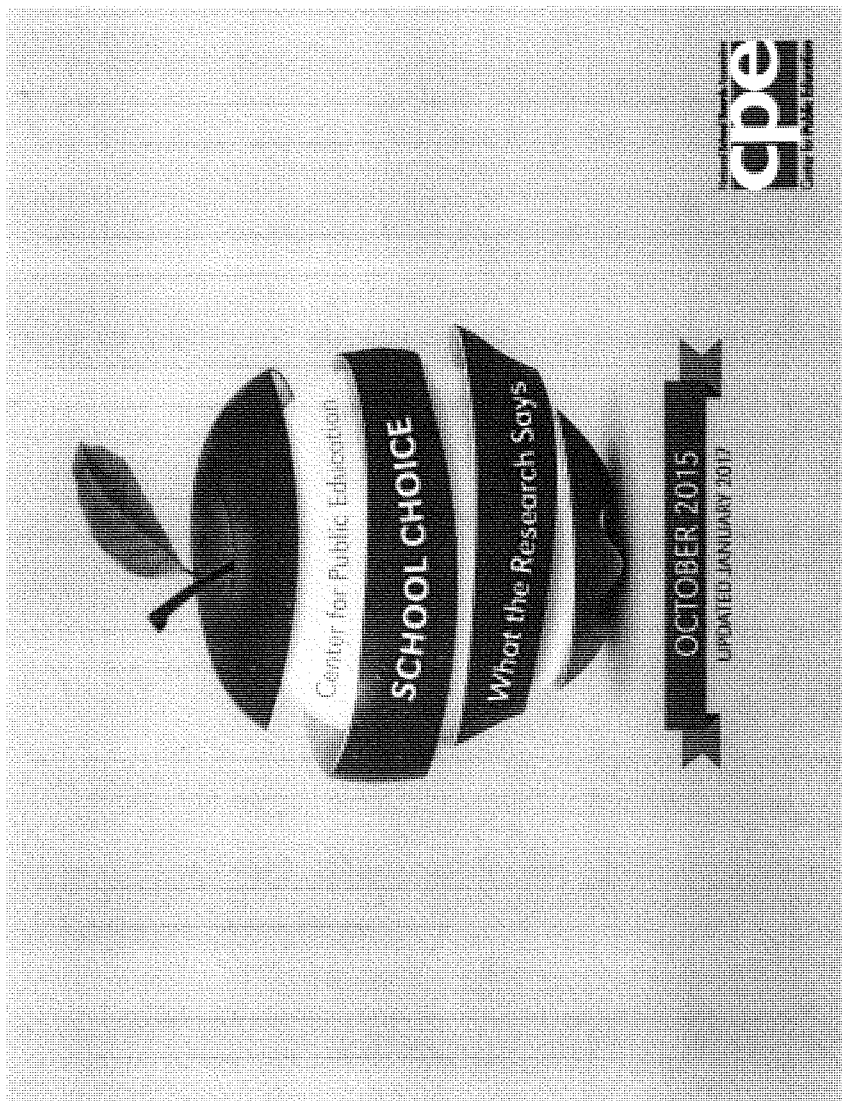



A School Choice Primer

Giving parents and students the ability to choose their school is promoted by supporters as the key to improving American education overall. On the surface, the idea has great appeal. Who, after all, opposes having choices? Indeed, both Democratic and Republican policymakers, including President Trump, have embraced school choice as a reform strategy, whether it's limited to alternatives within the public school system or provides taxpayer dollars to students to take to private schools or providers. For this reason alone, American voters should be asking: does school choice live up to its supporters' claims?

In 2015, NSBA's Center for Public Education sought to answer this question in an at-a-glance overview of school choice in all its permutations: choice within the public school system (traditional public schools, magnet and charter schools); choice outside the public schools (private schools, vouchers and tax credits, homeschooling); and virtual schools which can be either public or private.

We have updated this edition in order to include the results of new studies that shed more light on the impact of schools of choice. A few findings stand out. Unlike charter schools overall — which aren't as universally high performing as their publicity suggests — urban charter schools tend to perform well compared to their traditional counterparts. In contrast, online charters are even more ineffective than we previously understood them to be. And a major study of Louisiana vouchers showed a negative impact on student achievement after two years. Add it up and our conclusion is basically the same as it was a year ago. We find that school choices work for some students sometimes, are worse for some students sometimes, and are usually no better or worse than traditional public schools.

As before, we hope that this report will inform the ongoing conversation about the efficacy of school choice in the nation's efforts to assure every child is prepared for college, careers and citizenship.

TABLE OF CONTENTS

Reality Check.....	3
Public Schools.....	4
Magnet Schools.....	7
Charter Schools.....	8
Private Schools.....	10
Vouchers & Tuition Tax Credits.....	12
Homeschooling.....	14
Virtual Schools.....	16
Other Forms of School Choice.....	18
Take-aways.....	19
What Can School Boards Do?.....	20
A Disclosure/ Acknowledgments.....	21
Bibliography.....	22

REALITY CHECK

After more than two decades of choice policies, enrollments in schools of choice are still relatively small. **87%** of all school-aged children are in **public schools**.

SCHOOL TYPES	
PUBLIC	
Charter	4%
Magnet	4%
Other Public	8%
Traditional Neighborhood	71%
NON-PUBLIC	
Private	10%
Voucher	.5% in Private
Home Schooling	3%

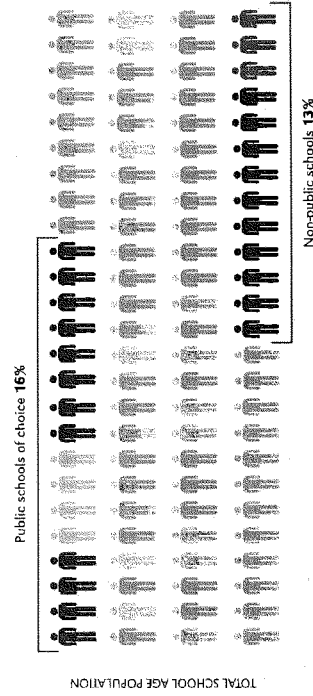

¹Other public includes inter- and intra-district transfers

PUBLIC SCHOOLS

DEFINITION

Public Schools

Every state provides a free, public education that is available to every school-age child in the state. Every state also has compulsory education laws, typically for children between ages **5-7 & 16-18**.

STATE POLICY



Public schools must meet all local, state & federal accountability standards.

ENROLLMENT

Public schools serve **87%** of the school-aged population.

Public School Students



PUBLIC SCHOOLS



Public Schools

By many measures, public schools are performing better than ever. High school graduation rates are at historic highs as is the math performance of 4th and 8th graders. Most public school students still attend traditional neighborhood schools, but they are being given more choices like magnet schools and charters within the public education system.

2011-12

81% of public high school students graduated on time.

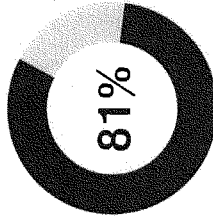

By age 24, **86%** had earned a diploma.

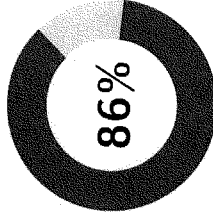

In 1995, U.S. 8th graders scored below the international average in math; 20 years later, they were well above the average and were outscored by only 6 of 33 participating countries.

Source: TIMSS, 2015

PUBLIC SCHOOLS

IMPACT **Public Schools**

Public School Student Gains on NAEP-Math
1990-2015

Today's public school 4th & 8th graders are performing two years ahead in math compared to their peers in 1990. They are reading about a half year ahead.

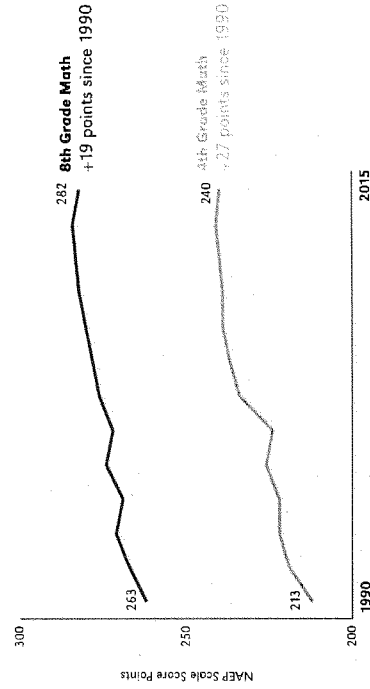

Source: National Assessment of Educational Progress 2015. 10 points on the NAEP scale is about one year's worth of learning.

PUBLIC SCHOOLS

DEFINITION

Magnet Schools

Public schools with specialized courses or curriculum. They can have admissions requirements, but they must meet local, state & federal accountability standards.

STATE POLICY

48 states have magnet schools

ENROLLMENT

About **4%** of all school-age children are in magnet schools.



IMPACT

Study results are somewhat mixed. Some show higher performance while others show similar results for magnet and non-magnet students.

IMPACT

Several studies have shown higher graduation rates for magnet students, especially for those in Career Academies — career focused high school programs.



PUBLIC SCHOOLS

DEFINITION

Charter Schools

Public schools with some autonomy in exchange for having to periodically renew their charter. Charter schools have open enrollment, cannot charge tuition, and must meet local, state & federal accountability standards.

STATE POLICY

44

states have charter schools

School boards are the largest group of charter school authorizers.

ENROLLMENT

Charters serve about **4%** of all school-age children.



Charter Students

PUBLIC SCHOOLS



Charter Schools

1 in 4 charter schools outperformed its traditional counterpart in reading. More than half performed about the same.

Charter Schools Performance Compared To Traditional Public School Counterpart

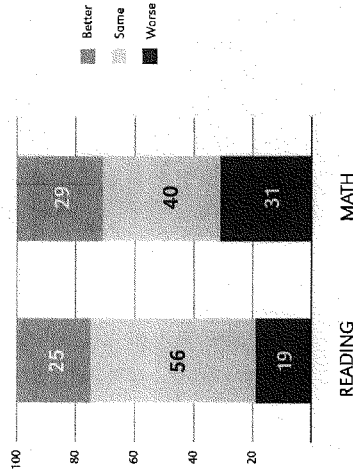

Source: CREDO, 2013

A 2015 CREDO analysis of urban charter schools tells a different story. More than half of charter schools in urban districts overall outperformed their traditional public school counterpart. The impact was highest in Boston, Newark and Memphis. Conversely, urban charter schools in Las Vegas and West Palm beach performed worse.

PRIVATE SCHOOLS

DEFINITION

Private Schools

Not free. Selective. Not open to every student.
No public accountability for student performance.

ENROLLMENT

Enroll about **10%** of total school-aged population, which has been consistent for the last four decades.

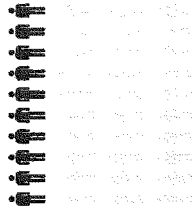

Private School Students

STATE POLICY

- States that require private schools to register with state Department of Education
- States that require registration for specific private schools
- States that allow private schools to be recognized by state Board of Education



Source: US Department of Education, 2009

IMPACT

Private school students score somewhat higher on NAEP than their public school peers, but the gap has been narrowing.

PRIVATE SCHOOLS

Private Schools

Public Versus Private School Performance

Private school students tend to outperform public school students on NAEP. But when researchers Lubinski & Lubinski controlled for student race, ethnicity & family income, they found the opposite – that in most cases, 4th and 8th grade public school students had the advantage in math scores over students in different kinds of private schools.

4th Grade Math

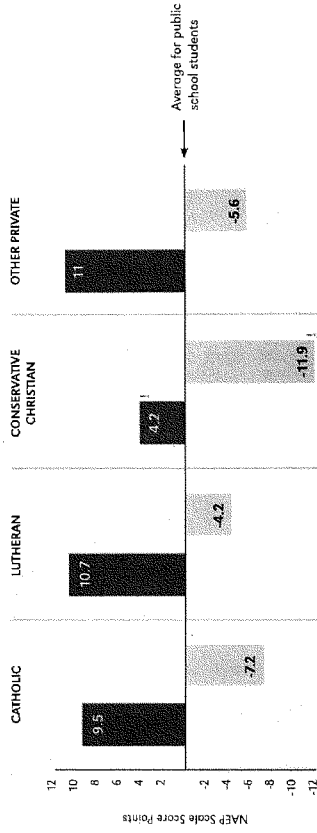

■ Raw scores ■ Scores controlled for demographics and location

! Not statistically significant, interpret with caution

PRIVATE SCHOOLS

Vouchers & Tuition Tax Credits

Impact of Vouchers on Student Achievement After 2 years

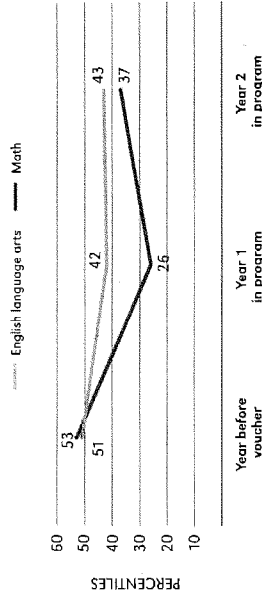

A major study of the Louisiana voucher program showed that public school students who used the voucher to enter a private school in 2011-12 were found to have lost academic ground two years later. Declines were evident in both reading and math.

Source: Abdulkadirglu et al., 2015

Some studies report test score gains for low-income, African American students; most show similar performance as public school students for other student groups.



Several studies have found voucher recipients are more likely to graduate from high school.

Accountability varies greatly by program; **20** require participating students to take standardized assessments while **18** have no accountability for student performance.

PRIVATE SCHOOLS

DEFINITION

Vouchers & Tuition Tax Credits

Taxpayer-funded scholarships that subsidize student tuition at private schools. Typically available to targeted groups, such as low-income students, those attending chronically low-performing schools, students with disabilities, or students in foster care.

STATE POLICY

- Offer vouchers
- Offer tuition tax credits
- Offers both

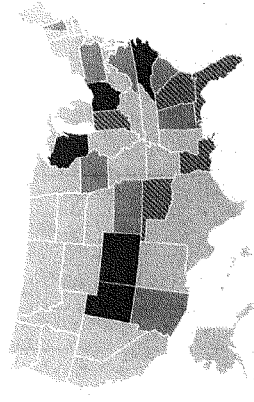

ENROLLMENT

Voucher students comprise less than 1/2 of 1% of all school-age children.

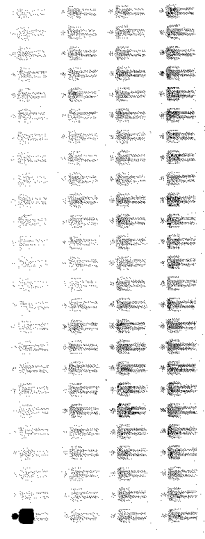

HOMESCHOOLING

DEFINITION Homeschooling

Students are taught at home by parents or tutors who determine content, virtual schooling can be a part of instruction.

STATE POLICY

13 states & DC have requirements for homeschool instructors; some require certain subjects

23 states & DC require testing for homeschooled students

14 states define performance thresholds

ENROLLMENT

Homeschooled students comprise 3% of the total school-aged population.



HOMESCHOOLING

 Homeschooling



IMPACT UNKNOWN

There is little reliable research on homeschooled students; consequently, little is known about them as a group.

Most studies are anecdotal or based on self-selected, self-reporting surveys.

Some small studies suggest higher SAT/ACT scores and college-going rates for homeschooled students; however, these studies represent homeschooled students overall is unknown.

VIRTUAL SCHOOLS

DEFINITION

Virtual Schools

Either public or private online schools. Can be either fully virtual or “blend” online & face to face instruction. Courses are purchased from private providers or developed by states and school districts.

STATE POLICY

30 states & DC operate virtual schools

ENROLLMENT

Enrollments are growing but currently serve less than **1%** of total school-age population.

Virtual Students



VIRTUAL SCHOOLS

Virtual Schools

Online Charter Schools Compared to Traditional Public Schools

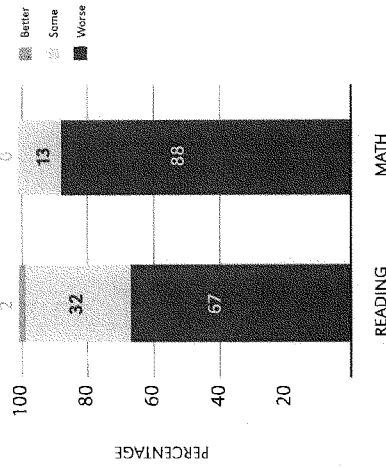

Source: CREDO, 2015



On-time graduation rates for full-time virtual schools are about half the national average



Studies suggest that students taking AP or other high-level courses online do well



Credit recovery is the most common reason students take online courses, but the overall effect is hard to determine.

Other Forms of School Choice

- **Inter- and Intra-district transfers:** Over 20 states allow students to transfer within or between school districts to other public schools. The combination of inter- and intra-district transfers with magnet and charter school enrollments shows that about 16% of school-age children attend a public school of their choice.
- **Education Savings Accounts:** Education Savings Accounts (ESA) are similar to vouchers in that qualifying families receive a portion of state funds for educating their child. They differ in that the dollars are deposited in a privately managed account and can be used for tutoring, curriculum and other approved services as well as for private school tuition.

Arizona and Florida were the first states to initiate small-scale ESA programs for special needs students. Arizona also offers ESAs to students in low-performing schools. In 2015, Nevada passed an ESA bill that represents the most far-reaching school choice program in the nation. According to the bill, Nevada will provide a large part of the state per-pupil allocation in the form of an ESA to students who are currently enrolled in the state's public schools but wish to leave. Experts estimate that about 93% of all school-age children would be eligible to participate. The Nevada Supreme Court recently called a permanent injunction against the program due to its funding mechanism. However, ESA advocates intend to introduce new legislation in 2017 that will re-launch the program with alternative funding.

Take-aways

- **There's no reason to conclude that choice in itself will produce better outcomes.** While many schools of choice do an exemplary job, the results aren't universally better than those produced by traditional public schools.
- **Non-public school choice should come with warning labels.** Policymakers who are considering supporting parents who wish to choose private schools or homeschooling should be aware that very little is known about the overall efficacy of schooling outside of public schools.
- **Expanding charter schools is not an overall reform strategy.** Most charter schools are no better than their traditional public school counterparts. Merely having more of them will not raise performance. Rather, policymakers and educators should focus on learning from successful charter schools about policies and practices that can help improve all schools.

What Can School Boards Do?

- Establish opportunities for sharing lessons learned between your traditional, magnet and charter schools. Learning from successes in your various programs can bolster the education provided all students in your district.
- Provide an adequate infrastructure for monitoring your students in virtual schools. Digital learning is the wave of the future and will have a central place in public education. But school boards need to make sure that it is done right so that students do not get lost in cyberspace.
- Establish policies for granting and revoking charters based on academic performance. Make sure these policies are well-known in order to attract stronger applications.

A Disclosure

The Center for Public Education is an initiative of the National School Boards Association (NSBA). While we have sought to be as objective as possible in this report, readers should be aware that NSBA has official positions on school choice, as follows:

- **Public education choice:** NSBA supports "locally elected school boards in expanding public school choices to meet the needs of students in a rapidly changing world." This support extends to charter schools as long as the local school board "retains sole authority" to grant and revoke charters.
- **Non-public education choice:** NSBA "recognizes and upholds the right of any group to establish and maintain schools so long as such schools are fully financed by their own supporters." At the same time, NSBA believes public tax dollars should "only support public schools" and opposes "vouchers, tax credits, and tax subsidies for use of non-public K-12 schools." NSBA further believes that "private and home schools should be subject to governmental regulation that assures a minimum standard of instruction under state law and adherence to the Constitution and laws of the United States."

Acknowledgments

We want to thank Patriaio Campbell, CPE's Spring 2014 intern, for her contribution to this report.

© Center for Public Education, 2015; 2017

The Center for Public Education is a national resource for credible and practical information about public education and its importance to the well-being of our nation. CPE provides up-to-date research, data, and analysis on current education issues and explores ways to improve student achievement and engage public support for public schools. CPE is an initiative of the National School Boards Association.
www.centerforpubliceducation.org

Founded in 1940, the National School Boards Association (NSBA) is a not-for-profit organization representing state associations of school boards and their more than 90,000 local school board members throughout the U.S. Working with and through our state associations, NSBA advocates for equity and excellence in public education through school board leadership. www.nsba.org

Bibliography

PUBLIC SCHOOLS

National Center for Education Statistics, *Public School Enrollments Projections, Condition of Education 2015*, U.S. Department of Education, Data for 2012-13, year: http://nces.ed.gov/ipeds/data/ipeds_indicators/...cga.asp

National Center for Education Statistics, *Compulsory School Attendance Laws by State, 2015*, U.S. Department of Education: https://nces.ed.gov/ipeds/data/ipeds_indicators/...1.asp

National Center for Education Statistics, *Public School High School Graduation Rates, Condition of Education 2015*, U.S. Department of Education, Data for 2011-12: http://nces.ed.gov/ipeds/data/ipeds_indicators/...01.asp

National Center for Education Statistics, *Trend in International Mathematics and Science Study (TIMSS), Figure 4: Trends over three time points, 2015*: https://nces.ed.gov/ipeds/data/ipeds_indicators/...01.asp

National Center for Education Statistics, *Nations Report Card 2015 Mathematics and Reading*, U.S. Department of Education: https://www.nationsreportcard.gov/reading_math_2015/#?grade=4

MAGNET SCHOOLS

National Center for Education Statistics, *Number and Enrollment of Public Elementary and Secondary Schools by School Level, Type, and Charter and Magnet status: Selected years, 1990-91 through 2010-11*, U.S. Department of Education: https://nces.ed.gov/ipeds/data/ipeds_indicators/...108.asp

Betts, Julian, Kirimto, Levin, Bos & Eaton, *What Happens When Schools Become Magnet Schools? American Institutes for Research, May 2015*: <http://www.oir.org/sites/default/files/downloads/report/Magnet-Schools-Diversity-and-Achievement-May-2015-rev.pdf>

Jerald, Craig J, *Keeping Kids in School, 2007*, Center for Public Education: <http://www.centerforpubliceducation.org/Main-Menu/StaffingStudents/Keeping-kids-in-school-At-a-glance/default.aspx>

Miami-Dade Public Schools, *A Review of the Research on Magnet Schools, January 2012*: <http://www.magnet.edu/files/documents/review-of-research-on-magnetschools.pdf>

CHARTER SCHOOLS

National Alliance for Public Charter Schools, *Total number of charter school students 2013-14*: <http://dashboards.publiccharters.org/dashboard/students/page/overview/year/2014>; *Total number of charter schools by state*: <http://dashboards.publiccharters.org/dashboard/schools/page/overview/year/2014>

Center for Research on Education Outcomes, *National Charter School Study, 2013*, Stanford University: <http://eredo.stanford.edu/documents/NCSS%202013%20Final%20Draft.pdf>

Center for Research on Education Outcomes, *Urban Charter School Study, 2015*, Stanford University: <https://urbancharters.stanford.edu/>

Hull, Jim. Charter Schools: Finding Out the Facts, March 2010. Center for Public Education: <http://www.centerforpubliceducation.org/Main/Menu/Organizing-a-school/Charter-schools-Finding-out-the-facts-At-a-glance>

PRIVATE SCHOOLS

National Center for Education Statistics. Private School Enrollments, 2011-12. Condition of Education 2015, U.S. Department of Education: <http://nces.ed.gov/ipeds/data/ipedsdatatools/indicators/cge.asp>

U.S. Department of Education. State Regulation of Private Schools, 2009 <https://www2.ed.gov/admins/comm/choice/regprivschl/regprivschl.pdf>

National Assessment of Educational Progress. Comparing Private Schools and Public Schools Using Hierarchical Linear Modeling, 2006, National Center for Education Statistics, U.S. Department of Education: <https://nces.ed.gov/nationsreportcard/pdf/studies/2006461.pdf>

Yettick, Hally. "Public schools outperform private schools, book says," Education Week, May 13, 2014 <http://www.edweek.org/ew/articles/2014/05/14/31publicprivate.n33.html>

Lubienski & Lubienski. The Public School Advantage: Why Public Schools Outperform Private Schools, University of Chicago Press, 2014

VOUCHERS

Abdulkadiroglu, Atilo, Pathak & Walters. Free to Choose: Can school choice reduce student achievement?, Working paper 21839. National Bureau of Economic Research, December 2015 <http://www.nber.org/papers/w21839.pdf>

American Federation for Children Growth Fund. School Choice Yearbook, 2014-15 http://afcgrowthfund.org/wp-content/uploads/2015/04/AFC_2014-15_yearbook.pdf

Gill, Brian, Timpane, Ross, Brewer & Booker. Rhetoric Versus Reality: What we know and what we need to know about vouchers and charter schools, 2007, RAND Education: http://www.rand.org/content/dam/rand/pubs/monograph_reports/2007/RAND_MK1118.1.pdf

Kober & Usher. Keeping Informed About School Vouchers: A review of major developments and research, Center on Education Policy, 2011: <http://www.cepd-uc.org/displayDocument.cfm?DocumentID=369>

Mills, Jonathan N., Egalite & Wolf, How has the Louisiana scholarship program affected students? A comprehensive summary of effects after two years, Education Research Alliance for New Orleans, Policy Brief, 2016: http://educationresearchallianceola.org/files/publications/ERA_Policy-Brief_Public-Private-School-Choice-160718.pdf

Wolf, Patrick, Gutman, Puma Kisaido, Rizzon, Elisa & Carr. Evaluation of the DC Opportunity Scholarship Program Final Report, June 2010, U.S. Department of Education: <http://ies.ed.gov/nese/pubs/20104018/pdf/20104019.pdf>

Wolf, Patrick. "Lost Opportunities," Fall 2009, Education Next: <http://educationnext.org/lost-opportunities/>

VIRTUAL SCHOOLS

Barth, Patte, Hull & St. Andrie, Searching for the Reality of Virtual Schools, May 2013, Center for Public Education: <http://www.centerforpubliceducation.org/Main/Menu/Organizing-a-school/Searching-for-the-reality-of-virtual-schools-at-a-glance/Searching-for-the-reality-of-virtual-schools-full-report.pdf>

Center for Research on Education Outcomes. Online Charter School Study, 2015, Stanford University: <http://credo.stanford.edu/pdfs/Online%20Charter%20Study%20Final.pdf>

Evergreen Education Group. Keeping Pace, 2013-14: <http://www.kpk12.com/sites/>

Miron, Gary, Gulosino & Horvitz, Virtual Schools in the U.S. 2014; Politics, Performance, Policy and Research Evidence, National Education Policy Center: <https://nepc.colorado.edu/files/virtual20143-inventory-final.pdf>

HOMESCHOOLING

Fulton, Mary, State Policies on Homeschooling, October 2009, Education Commission of States: <http://www.ecs.org/clearinghouse/82/30/8230.pdf>

National Center for Education Statistics, Digest of Education Statistics, 2013, Table 206.10 (2012 data), U.S. Department of Education: <https://nces.ed.gov/ipeds/data/ipedsdatatools/tables/206.10.asp?current=yes>

U.S. Department of Education, State Regulation of Private Schools, 2009 <https://www2.ed.gov/admins/comm/choice/regprivschl/regprivschl.pdf>

OTHER: INTER/INTRA-DISTRICT CHOICE, ESAS
National Center for Education Statistics, Trends in School Choice 1992-2007, U.S. Department of Education: <http://nces.ed.gov/pubs2010/2010004.pdf>

Cunningham, "Nevada enacts nation's most expansive school choice program," June 10, 2014, National Conference of State Legislatures: <http://www.ncsl.org/blog/2015/06/10/nevada-enacts-nations-most-expansive-school-choice-program.aspx>

Prothero, Arianna, Nevada high court deals blow to school choice program, Education Week, October 4, 2016: <http://www.edweek.org/ew/articles/2016/10/05/nevada-high-court-deals-blow-to-school.html>

 storyboard

DEEPER Learning

A Georgia school teaches skills that
translate to the workplace

Thomas J. Gentzel and Richard Anderson

A decade in business gave Billy Heaton unexpected insights about educational priorities. During 10 years in the contracting industry, Heaton vividly recalls working with other professionals—from architects to subcontractors—who lacked some of the most fundamental, valuable abilities anyone can carry into the workplace.

"One of the biggest obstacles we faced was dealing with people who just didn't know how to work well in a group, how to collaborate, how to listen, or how to communicate well," he says.

Heaton traded in his business card for a career in school administration. He's currently the principal at Clairemont Elementary School in Decatur, Georgia. Clairemont is a K-3 school that uses a learning model based on practical experiences and student projects called expeditionary learning.

Expeditionary learning seeks to cultivate the same skills that some of Heaton's business associates failed to master. "The practices and principles of expeditionary learning teach skills that I saw as lacking in some of my colleagues in the business world. Those types of lifelong skills are important, and they're learned by our students as they work with people out in the community who are in the business field."

Lifelong skills are the bedrock of expeditionary learning. It involves hands-on lessons that impart critical thinking skills, problem solving, collaborative activities, and socialization. It emphasizes practical learning methods while incorporating a strong element of community involvement.

Heaton notes that students don't do "field trips" at Clairemont. They do "field work." Students collect data, conduct research, and interview experts and professionals over the course of an expedition in order to create a finished work product.

Heaton is thrilled with the results. "Our teachers regularly bring in experts and work with students on projects and the development of products," he says. "All of the K-3 schools here in Decatur also use experts to provide students with feedback or to help critique students' work. It's a very collaborative effort in which students are exposed to professionals in a given field."

TWO-WAY CONNECTIONS

That partnership is also a two-way street. Business people are able to see the challenges that educators and students face while gaining a greater understanding of those issues. At the same time, business leaders who are involved in expeditionary learning help foster a connection between the classroom and the community.

PHOTOS COURTESY OF THE CITY SCHOOLS OF DECATUR



deeper learning

That connection is at the forefront of the work the students produce. For example, second-graders at Clairemont are creating an almanac. They're using local resources to research the information that will be composed for and included in the almanac, which will be donated to the City of Decatur's library upon completion.

"What I love about the expeditionary learning framework is that, even beginning in kindergarten, it's developing the skills that these kids will need when they go out into the real world," Heaton says. "We're trying to start instilling these skills as early as possible."

Those executive functioning skills are the ones employers value most: critical thinking, absorbing and incorporating feedback into one's work, communicating

effectively, knowing and mastering essential academic content, and creative problem solving.

Collectively, these competencies form the nucleus of an innovative, research-supported educational model called "deeper learning," of which expeditionary learning is one type.

Deeper learning emphasizes executive functioning skills that today's employers require. It helps children develop into well-rounded students who have the abilities that they'll need to thrive in the modern job market. Deeper learning helps students succeed in college, the workforce, and society in general.

Project-based learning, like the expeditionary model, is a centerpiece of deeper learning. It teaches kids real-world know-how in an environment that also stresses those crucial executive functioning skills.

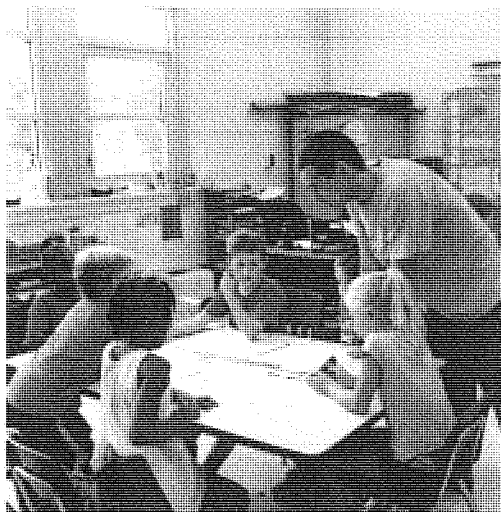

Collaborative activities are a part of Clairemont's classwork.

SKILLS GAP

All of that is more important than ever for the next generation of American workers. Our country is in the midst of a potentially crippling "skills gap," meaning that there aren't enough qualified workers to fill available positions.

The business leader organization ReadyNation highlights startling research that shows just how severe this problem is: Nationwide, 65 percent of job openings by the end of the current decade will require some form of postsecondary education. However, only 60 percent of American workers possess that level of education.

That 5-percent gap means that, unless trends shift, there may be 2.75 million unfilled positions. In Clairemont's home state of Georgia alone, there will be nearly 85,000 jobs for which there won't be qualified applicants.

Even more alarming, the skills gap is especially significant in STEM fields (science, technology, engineering, and mathematics), which is a sector of industry that is growing rapidly.

The skills gap matters a great deal for Georgia companies like Delta Air Lines. Business leaders at major employers like Delta understand how vital it is to develop a workforce that has the deeper-learning skills necessary for success. And the business community wants to help grow and foster the next generation of good employees that will boost the state and local economies in Georgia and elsewhere.

Ensuring that all students graduate from high school well prepared for postsecondary education and a rapidly changing global workplace is a major priority of the National School Boards Association. Achieving that goal requires rigorous academic preparation as well as vital skills such as the ability to acquire needed information, to think critically and be creative in applying what has been learned, and to work effectively with others in developing and implementing solutions to challenging problems.

Valarie Wilson, the executive director of the Georgia School Boards Association, sees expeditionary learning as a success story.

"With expeditionary learning, teaching doesn't just involve students sitting in their chairs," Wilson says. "Children in the school do their projects, and then they have to present them and talk about what they're doing. They learn how to focus the presentation on key facts and how to figure out not only what to say, but how to say it to others."

Wilson also points out that parents support expeditionary learning and are able to see the positive difference it makes in their child's life.

ALIGNMENT AND COLLABORATION

Unsurprisingly, Clairemont has become an expeditionary learning "mentor school." It has also earned a National Blue Ribbon School award. It was the first elementary school in the district to use the expeditionary learning model.

In fact, the students at Clairemont performed so well that the Decatur City Schools Board of Education decided to introduce the program into the other elementary schools in the district.

That piece of Clairemont's story underscores another reason for the success of the program: excellent alignment between school board and school district. When districts and boards work in concert to bolster effective learning models, everyone wins.

It seems appropriate that the success of the expeditionary learning program is based in part on a core deeper learning competency: collaboration.

Billy Heaton sees the difference that expeditionary learning already makes in the children's lives.

He speaks of the academic mindset expeditionary learning creates when he says, "We let kids know that

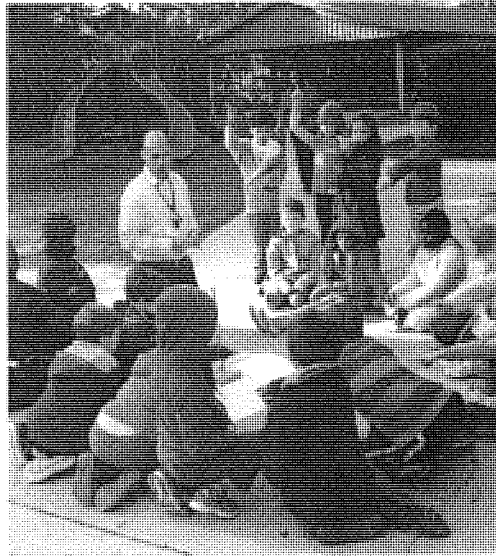

Clairemont students do field work, not field trips.

they aren't perfect. They are going to make mistakes. But they have to know that they can take those mistakes and use them as learning opportunities, which is a great lifelong skill." But the lessons extend far beyond the classroom.

Heaton says, "Overall, I've just been blown away by how kind kids here at Clairemont are to each other."

Thomas J. Gentzel (tgentzel@nsba.org) is the executive director and CEO of NSBA. Richard Anderson (rhale55@icloud.com) is the executive chairman of the board and retired CEO of Delta Air Lines in Atlanta.

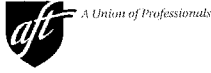

February 1, 2017

Committee on Education and the Workforce
Sub-Committee on Early Childhood, Elementary and Secondary Education
U.S. House of Representatives
Washington, D.C. 20510

Dear Chairman Rokita and Ranking Member Polis:

As you hold a subcommittee hearing on "Helping Students Succeed Through the Power of School Choice," I write on behalf of the 1.6 million members of the American Federation of Teachers to share our views on the real value of "choice" in education.

The AFT supports high-quality public school choice options if those schools are held to the same accountability and transparency standards as traditional public schools. We have a long history of supporting charter schools—when they are designed to live up to their original purpose, which is to be a laboratory for innovation that can share successful instructional strategies with the broader education community. And we have long supported magnet schools and their original intent to make public schools more diverse.

If your "school choice" hearing is about improving the quality of charter school options or increasing the investment in magnet schools, then it's about helping students. However, if this hearing is designed to promote policies that allow taxpayer dollars to be spent on unaccountable private schools, then this hearing is simply about giving private schools a choice—a choice to admit or reject students based on academic standing, behavioral history, LGBTQ status, religion or gender. If that's the case, this hearing is really to support taxpayer funding going to private schools that can choose if students with disabilities receive the services they need to succeed—the very services that federal law guarantees they will receive at public schools. If this hearing is promoting private school "choice," then this hearing is promoting a private school's choice to refuse to provide English language services to students, or to employ uncertified teachers, or to teach factually inaccurate curriculum. School choice is not really about options for students—it is about a school's choice.



The American Federation of Teachers is a union of professionals that champions fairness, democracy, economic opportunity, and high-quality public education, healthcare and public services for our students, their families and our communities. We are committed to advancing these principles through community engagement, organizing, collective bargaining and political activism, and especially through the work our members do.

American Federation
of Teachers, AFL-CIO

AFT Teachers
AFT PSRP
AFT Higher Education
AFT Public Employees
AFT Nurses and Health
Professionals

555 New Jersey Ave. N.W.
Washington, DC 20001
202-679-4400
www.aft.org

Randi Weingarten
PRESIDENT

Loretta Johnson
SECRETARY-TREASURER

Mary Kathryn Ricker
EXECUTIVE VICE PRESIDENT

VICE PRESIDENTS

Shelvy Y. Abrams
Mary J. Armstrong
Barbara Bowen
Christine Campbell
Zeph Capro
Alex Caputo-Pearl
Donald Carliso
Larry J. Carter Jr.
Kathy A. Chavez
Melissa Cropper
Evelyn DeJesus
Marietta A. English
Eric Feaver
Francis I. Flynn
Catalina Fortino
David Gray
David Hecker
Jan Hochadel
Fredrick C. Ingram
Jerry E. Jordan
Ted Kirsch
Frederick E. Kowal
Karen G. Lewis
Karen E. Magee
Louis Maffaro
Joanne M. McCall
John McDonald
Martin Messner
Daniel J. Montgomery
Michael Mulgrew
Ruby J. Newbold
Candice Oxley
Andrew Pallotta
Joshua Pechthalt
Paul Pecorale
David J. Quinke
Stephen Rooney
Denise Specht
Wayne Spence
Tim Stoebl
Richard Stutman
Ann Twomey
Adam Urbanski



Sub-Committee on Early Childhood, Elementary & Secondary Education / Page 2

So, what the research shows should come as no surprise: School choice policies like private school vouchers, education savings accounts, and tuition tax credits do not actually improve student achievement. What they do is undermine the rights of students and parents at the same time they siphon needed resources away from our nation's public schools. Let's work together to help students succeed by supporting the schools that 90 percent of the nation's children attend: our public schools.

Sincerely,

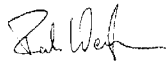
A handwritten signature in black ink, appearing to read "Randi Weingarten". The signature is fluid and cursive, with a long horizontal stroke at the end.

Randi Weingarten
President

RW:emc opeiu#2 afl-cio



Texas Association of School Boards
P.O. Box 400 • Austin, Texas 78767-0400 • 512.467.0222
12007 Research Blvd. • Austin, Texas 78759-2439 • www.tasb.org

Serving Texas Schools Since 1949

February 1, 2017

The Honorable Virginia Foxx
Chairwoman, U.S. House Education and the Workforce Committee
2176 Rayburn House Office Building
Washington, D.C. 20515

Dear Chairwoman Foxx:

The Texas Association of School Boards (TASB) urges Congress to consider the vast array of choice available within the public school system before devoting scant resources to support choice options that have shown little statistical advantage compared to the current system.

At least 880 Texas school districts out of 1,024 have adopted “open enrollment” policies that allow for interdistrict transfers of students from outside the district into the district at no cost. Of the remaining districts, many provide exceptions for students who live within a certain radius of the district, nonresident children of district employees, or specialty programs such as dual language, enhanced career and technical education, and early college high schools. Furthermore, the majority of our Texas public school districts partner with community colleges and/or universities to offer choices such as dual credit and distance learning, in addition to the Texas Virtual School Network.

In urban and fast-growth areas, student choice remains strong as school districts continue to innovate within traditional campuses and by offering specialty and magnet programs. Some independent school districts – such as Garland ISD, Pharr-San Juan-Alamo ISD and Spring Branch ISD – have partnered with charter schools to provide even more options for their students. All of the options are available without invoking a private school voucher, grant or subsidy for a school for which a student still may not qualify or be able to afford even with federal or state aid.

Additionally, more than 350 of these larger urban and suburban districts that have multiple campuses have policies allowing for transfers to different schools and programs within the district, giving students an ever-expanding array of public schools and programs to explore.

To the extent that voucher and grant programs are meant to address schools that are not meeting academic expectations, the Public Education Grant (PEG) program, Texas law since 1995, already allows students from state-identified, low-performing schools to transfer to another school in the district or to a school in another district and requires the

receiving district to consider the student without regard to race, religion, color, sex, disability, national origin, language, socioeconomic status, or academic achievement. Private schools do not have such mandates, often have additional admissions standards, and have little obligation to accept students from struggling schools.

TASB also urges efforts to “level the playing field” so that independent school districts may access the increased flexibility afforded to charter schools and district performance may be adequately compared to public charters.

The Texas Legislature passed legislation (House Bill 1842, 84th Session) that allows independent school districts to become “Districts of Innovation.” This allows districts to exempt themselves from most state laws that do not apply to charter schools – allowing school leaders to innovate and customize their educational programs to best meet the needs of their students. While it has only been two years, many districts have opted to access these flexibilities to regain local control over school calendars, class sizes and teacher certification requirements for career and technical education courses.

Students have more choices than ever through their local public schools, whether they be independent school districts or open enrollment charter schools. Between multiple transfer options, dual credit partnerships, and distance learning, school choice is already alive and well in Texas public schools and across the nation.

Above all, TASB stands for accountability and transparency of state and federal taxpayer dollars that is best exemplified through locally elected school board oversight of public schools. Voucher schemes, such as tax credit scholarships and tuition reimbursements, eliminate accountability and transparency by funneling public dollars, especially those that bypass the U.S. Treasury, to private institutions. The current model of public education provides taxpayers with choice, accountability and quality.

Sincerely,

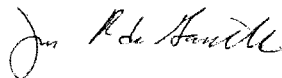

James de Garavilla
Chair, TASB Board of Directors Legislative Committee
Board Vice President, Silsbee Independent School District
800.580.4885
james.degaravilla@silsbeisd.org



1201 16th St., N.W. | Washington, DC 20036 | Phone: (202) 833-4000

Lily Eskelsen García
President

Rebecca S. Pringle
Vice President

Princess R. Moss
Secretary-Treasurer

John C. Stocks
Executive Director

February 1, 2017

Dear Representative:

On behalf of the three million members of the National Education Association and the students they serve, we write to offer our views on the House Education and the Workforce Subcommittee on Early Childhood, Elementary, and Secondary Education's hearing "Helping Students Succeed Through the Power of School Choice."

Public education is the foundation of our 21st-century democracy. Educators strive every day to make public schools a place that welcomes every student and prepares them to reach their full potential and contribute to our society, economy, and citizenry. We expect our elected leaders and policymakers, regardless of party affiliation, to value and support this uniquely American vision for a strong and inclusive public education system that ensures that all students can succeed, regardless of their zip code.

Private school vouchers – and similar schemes like tuition tax credits and education savings accounts - deprive students of important rights and protections and undermine public schools which educate nine out of 10 students. Private schools that participate in the voucher programs receive public money, but they are not subject to all the federal civil rights laws that public schools must meet—they may discriminate against a student based on his or her gender, disability, religion, economic background, national origin, academic record, English language ability, or disciplinary history. Students with special needs who use vouchers lose many rights granted under IDEA and may not have the protection of an individualized education plan. As a result, a significant number of students with special needs reject vouchers or leave voucher schools because they fail to provide essential services (*Evaluation of the D.C. Opportunity Scholarship Program*, U.S. Department of Education, June 2010). Students may also suffer because private schools are not subject to the same oversight, transparency, and accountability standards as public schools.

Take for example the data from the U.S. Department of Education on the only federally funded voucher program, all four congressionally mandated reports on the D.C. voucher program's impact on student achievement (published in [June 2010](#), [March 2009](#), [June 2008](#), and [June 2007](#)) found no significant improvement in reading or math scores among participants. The program also had no impact on students' satisfaction, motivation, engagement, or perceptions of school safety. Moreover, participating students were less likely to have access to key services such as ESL programs, learning supports, special education supports and services, and counselors.

Charter schools should operate in a manner that is transparent and accountable to parents and taxpayers, just like other taxpayer-funded schools; ensures equity and access; and solicits and

benefits from input from parents, educators, and the communities they serve. We caution, however, that charter schools are not a panacea for solving all education challenges.

The Every Student Succeeds Act provides some opportunities for boosting accountability, transparency, and equity in state charter sectors, however it is still lacking on key concerns such as public disclosure of non-public funding amounts and length of commitments; disclosure of student behavior codes and disciplinary policies; reporting of student retention rates; staff hiring and retention rates; clear requirements in state law regarding authorizers and conflicts of interest; public reporting of data on applications received and status of approved schools, among others.

If we are serious about every child's future, then let's get serious about doing what works. That includes providing the funding our public schools need so they can offer well-rounded curricula, early education, extracurricular activities and community support services, such as nutrition and health care. Let's invest in smart strategies that we know help to improve the success of all students, including classes small enough for one-on-one attention, modern textbooks and a well-rounded curriculum. Resourced neighborhood public schools that are desirable places to be and learn are our best bet for setting every student in America off to a great future. We stand ready to work with members of this Committee and Congress to achieve this vision for public education.

Sincerely,

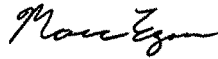
A handwritten signature in black ink that reads "Marc Egan". The signature is written in a cursive style with a large, stylized 'M' and 'E'.

Marc Egan
Director of Government Relations

NCPE National Coalition for
PUBLIC EDUCATION

February 1, 2017

The Honorable Todd Rokita
Chairman, Subcommittee on Early
Childhood, Elementary, and Secondary
Education
Education and Workforce Committee
U.S. House of Representatives
Washington, D.C. 20515

The Honorable Jared Polis
Ranking Member, Subcommittee on Early
Childhood, Elementary, and Secondary
Education
Education and Workforce Committee
U.S. House of Representatives
Washington, D.C. 20515

Re: NCPE Opposes Private School Vouchers

Dear Chairman Rokita and Ranking Member Polis:

The 50 undersigned organizations submit this letter for the hearing "Helping Students Succeed through the Power of School Choice" to express our strong opposition to private school vouchers. Vouchers divert desperately-needed resources away from the public school system to fund the education of a few, select students, with limited, if any, real impact on student academic achievement. Instead of providing equal access to high quality education or setting high standards for accountability, voucher programs have proven ineffective, lack accountability to taxpayers, and deprive students of rights provided to public school students. Congress would better serve *all* children by using funds to make public schools stronger and safer than by creating a new voucher program.

Although promoted as "school choice," private school vouchers do not provide real choice for students and parents. The "choice" in voucher programs actually lies with private schools, which may turn students away for a variety of reasons. In contrast, public schools are open to all.

Students with disabilities are particularly underserved by voucher programs. Private voucher schools do not adequately serve students with disabilities, often denying them admission or subjecting them to inappropriate or excessive suspensions or expulsions. They also generally do not provide them the same quality and quantity of services available to students in public schools, including those mandated under each student's individualized education plan (IEP). For example, in D.C., a significant number of students who received a voucher had to reject their vouchers because they were unable to find a participating school that offered services for their learning or physical disability or other special needs.¹

¹ U.S. Dep't of Educ., Evaluation of the D.C. Opportunity Scholarship Program: Final Report, 24-26 (June 2010) (The report found that 21.6% of parents who rejected a voucher that was offered to their child did so because the school lacked the special services that their child needed,¹ and, 12.3% of the parents who accepted a voucher for their child but then left the program cited a lack of special needs services at the school they had chosen).



The **National Coalition for Public Education** comprises more than 50 education, civic, civil rights, and religious organizations devoted to the support of public schools. Founded in 1978, NCPE opposes the funnelling of public money to private and religious schools through such mechanisms as tuition tax credits and vouchers.

www.NCPEcoalition.org

Vouchers also fail to improve academic opportunities. Recent studies of both the Louisiana² and Ohio³ voucher programs revealed that students who used vouchers actually performed worse on standardized tests than their peers who are not in the voucher programs. Multiple studies of the D.C.,⁴ Milwaukee,⁵ and Cleveland⁶ school voucher programs revealed similar findings: students offered vouchers do not perform better in reading and math than students in public schools. In fact, the Department of Education studies of the D.C. voucher program show that students participating in the program are actually *less* likely to have access to ESL programs, learning support and special needs programs, tutors, counselors, cafeterias, and nurse's offices than students not in the program.

Moreover, voucher programs offer little accountability to taxpayers. Private school voucher programs usually do not require participating private schools to comply with the same teacher standards, curriculum, reporting, and testing requirements as public schools. And, private schools that receive voucher students do not adhere to all federal civil rights laws including those in Title IX, the Individuals with Disabilities Education Act (IDEA), and ESSA, religious freedom protections provided under the First Amendment of the U.S. Constitution, and public accountability standards that all public schools must meet.

Finally, vouchers violate religious liberty by funding primarily religious schools.⁷ One of the most dearly held principles of religious liberty is that government should not compel any citizen to furnish funds in support of a religion with which he or she disagrees, or even a religion with which he or she *does agree*. Voucher programs, however, violate that central tenet: they use taxpayer money to fund primarily religious education. Parents certainly may choose such an education for their children, but no taxpayer should be required to pay for another's religious education.

For these reasons and more, we oppose private school vouchers. Congress should ensure that public dollars remain invested in public schools for the benefit of all students.

Thank you for your consideration of our concerns.

Sincerely,

² Morgan Winsor, *Louisiana's Controversial Voucher Program Harms Poor Students, Lowers Grades, New Study Finds*, *Int'l Bus. Times* (Jan. 10, 2016).

³ David Figlio & Krzysztof Karbownik, Fordham Institute, *Evaluation of Ohio's EdChoice Scholarship Program: Selection, Competition, and Performance Effects* 32 (July 2016).

⁴ *E.g.*, U.S. Dep't of Educ., *Evaluation of the D.C. Scholarship Program: Final Report* (June 2010) (Although the 2009 study showed a marginal gain for some students in reading (but notably, not for the program's targeted group, students from schools in need of improvement), the 2010 Final Report said "[t]here is no conclusive evidence that the [program] affected student achievement" and earlier findings of modest gains "could be due to chance" and were no longer statistically significant.).

⁵ *E.g.*, Patrick J. Wolf, School Choice Demonstration Project, Univ. of Ark., *The Comprehensive Longitudinal Evaluation of the Milwaukee Parental Choice Program: Summary of Final Reports* (Apr. 2010). (Overall, there are no significant achievement gains of voucher students compared to public school students. "When similar MPCP and MPS students are matched and tracked over four years, the achievement growth of MPCP students compared to MPS students is higher in reading but similar in math. The MPCP achievement advantage in reading is only conclusive in 2010-11, the year a high-stakes testing policy was added to the MPCP.")

⁶ *E.g.*, Jonathan Plucker et al., Center for Evaluation & Education Policy, Univ. of Ind., *Evaluation of the Cleveland Scholarship and Tutoring Program: Technical Report 1998-2004* 166 (Feb. 2006).

⁷ *See, e.g.*, U.S. Dep't of Educ., *Evaluation of the D.C. Opportunity Scholarship Program: Final Report*, 17-18 (June 2010) (finding that approximately 80% of the students participating in the D.C. voucher program attend religious schools).



The **National Coalition for Public Education** comprises more than 50 education, civic, civil rights, and religious organizations devoted to the support of public schools. Founded in 1978, NCPE opposes the funneling of public money to private and religious schools through such mechanisms as tuition tax credits and vouchers.

AASA: The School Superintendents Association
 African American Ministers In Action
 American Association of University Women (AAUW)
 American Atheists
 American Civil Liberties Union (ACLU)
 American Federation of Labor-Congress of industrial Organizations (AFL-CIO)
 American Federation of School Administrators
 American Federation of State, County, and Municipal Employees (AFSCME)
 American Federation of Teachers, AFL-CIO
 American Humanist Association
 Americans for Democratic Action (ADA)
 Americans for Religious Liberty
 Americans United for Separation of Church and State
 Anti-Defamation League
 Association of Education Service Agencies
 Association of School Business Officials International (ASBO)
 Association of University Centers on Disabilities
 Baptist Joint Committee for Religious Liberty
 Center for Inquiry
 Clearinghouse on Women's Issues
 Council of Administrators of Special Education
 Council for Exceptional Children
 Council of the Great City Schools
 Disability Rights Education & Defense Fund
 Disciples Justice Action Network
 Equal Partners in Faith
 Freedom From Religion Foundation
 Institute for Science and Human Values
 Interfaith Alliance
 League of United Latin American Citizens
 National Alliance of Black School Educators
 NAACP
 National Association of Elementary School Principals
 National Association of Federally Impacted Schools
 National Association of Secondary School Principals
 National Association of State Directors of Special Education
 National Black Justice Coalition
 National Center for Learning Disabilities
 National Council of Jewish Women
 National Disability Rights Network
 National Education Association
 National Organization for Women
 National PTA
 National Rural Education Advocacy Collaborative



The **National Coalition for Public Education** comprises more than 50 education, civic, civil rights, and religious organizations devoted to the support of public schools. Founded in 1978, NCPE opposes the funnelling of public money to private and religious schools through such mechanisms as tuition tax credits and vouchers.

National Rural Education Association
People For the American Way
School Social Work Association of America
Secular Coalition for America
Texas Freedom Network
Union for Reform Judaism



The **National Coalition for Public Education** comprises more than 50 education, civic, civil rights, and religious organizations devoted to the support of public schools. Founded in 1978, NCPE opposes the funnelling of public money to private and religious schools through such mechanisms as tuition tax credits and vouchers.

www.NCPEcoalition.org

Mr. SCOTT. Thank you, Mr. Chairman. One of the challenges we have as legislators is making the best use of the taxpayer's dollars. We know that we don't have enough money for teacher salaries and counselors, after-school programs, reading recovery programs, programs we know actually work. We also know that research on voucher programs are clear, they do not lead to academic benefits for low-income students. Studies on school choice programs in Cleveland, Milwaukee, in Washington, D.C., found that students in these programs do not perform any better than students who do not receive the vouchers. In fact, in both in Louisiana and Ohio, students participating in voucher programs actually performed notably worse than their public school counterparts. So if you have no evidence this is actually working, it is a challenge of why we should be spending money in that rather than things we know that actually work.

Mr. WILLIAMS, in the program -- in the voucher programs that you had oversight of, was the number of vouchers infinite or were they limited?

Chairman ROKITA. Mr. Williams, why don't you use your microphone, please.

Mr. WILLIAMS. As Commissioner of Education in the State of Texas, I did not have jurisdiction over private voucher programs.

Mr. SCOTT. And the programs you are aware of, are the vouchers infinite or are they limited?

Mr. WILLIAMS. They are both. I mean -- some of the programs are limited, as is, I think, we have --

Mr. SCOTT. Then how do you decide who gets a voucher and who doesn't get a voucher?

Mr. WILLIAMS. That is going to be decided by the State, by the State education agency as it develops its program.

Mr. SCOTT. So the choice isn't on the part of the parents, the choice is whoever gets to decide who gets a voucher.

On the programs that you have, have you seen studies that show that the number of people in private schools actually go up when you have a voucher program?

Mr. WILLIAMS. The number of participants or --

Mr. SCOTT. Number of total students in a school system in private schools, does the number in private schools go up when you have a voucher program, and the number of people in public schools go down?

Mr. WILLIAMS. It goes down but slightly. I mean, you think about --

Mr. SCOTT. Doesn't go down by the number of the people in the voucher program. If you have 1,000 vouchers, the number of people in public school doesn't go down by a 1,000. Is that right?

Mr. WILLIAMS. It does not.

Mr. SCOTT. Ok.

Mr. WILLIAMS. And in Texas, it would not because of the dramatic increase in terms of enrollment, that we sort of enroll about 85,000 new students in Texas schools every year so that would not have an adverse impact upon the number of youngsters in Texas schools. As I was going to say earlier --

Mr. SCOTT. A lot of the vouchers go to people that would have been in private school anyway.

Mr. WILLIAMS. It could very -- that could happen, that could happen.

Mr. SCOTT. Okay.

Mr. WILLIAMS. But it also could go to individuals that would not otherwise be in private school.

Mr. SCOTT. In fact, two-thirds of the students in Wisconsin and half the students in Indiana were already enrolled in private schools before they received a voucher.

On civil rights, people talk about the choice of public schools, Mr. Williams. Who gets to choose who gets into a school, is it the school or the parent?

Mr. WILLIAMS. Well, it's going to be the parent, going to make the determination about which school they wish to go to.

Mr. SCOTT. And does the school have to take them?

Mr. WILLIAMS. It depends upon how we established as State education administrations, how we establish what the rules of eligibility and rules of being able to come into that --

Mr. SCOTT. Do any of the rules allow the school to decide who gets in and who doesn't get in?

Mr. WILLIAMS. There are certain circumstances under which that might occur, yes.

Mr. SCOTT. So it's not the parent, it's the school. What about disciplinary processes? Does the school get to decide its disciplinary processes where they can kick kids out of school?

Mr. WILLIAMS. The rules for discipline will be no different whether that youngster is coming to that school with a voucher or whether that youngster is coming to school without one.

Mr. SCOTT. That's right. The school decides the discipline program.

Mr. WILLIAMS. If I --

Mr. SCOTT. In IDEA. My time is about to run out. In IDEA -- if the school does not want to meet the needs of the student, it is the parents' obligation to find a school that does want to meet those, rather than everybody has to comply with the Individuals with Disabilities Education Act?

Mr. WILLIAMS. Those parents will always have the opportunity to return to their home public school. That is always there.

Mr. SCOTT. The point is that the school does not -- thank you, Mr. Chairman -- the school does not have to comply with Individuals with Disabilities Education Act, and that's one of the problems with many of these vouchers.

Mr. WILLIAMS. I am sure we'll have an opportunity for me to discuss that later.

Chairman ROKITA. Mr. Williams, do you want to answer the question very briefly?

Mr. WILLIAMS. It has been longstanding for -- at the Department of Education, that IDEA does not attend to those privately placed students.

Chairman ROKITA. The gentleman's time has expired. The gentleman from Indiana, Mr. Messer, is recognized for 5 minutes.

Mr. MESSER. With all due respect to my friend from Virginia, so much information -- so much misinformation and so little time. I mean, we as policymakers sometimes make uncomplicated things very complicated. The reality is this: we work through these poli-

cies as a Nation. If we stay focused on kids and we stay focused on parents, this all gets really simple. Some of the information he put forward -- Mr. Scott put forward -- he mentioned the fact that some studies show that kids don't improve much in these programs. Firstly, no studies show legitimate decline. The fact of the matter is that parents' satisfaction in these schools is very high, which is another way of saying that the parents that choose to send their child to a school feel much better about the life of their child.

Ms. Carter and Mrs. Cherry -- I admire Mr. Williams and Kubacki for your leadership and for being here as well. As parents, I admire you for coming here and testifying -- Ms. Carter, I actually have a nephew who is autistic, and certainly empathize with your point that we need to make sure every kid in America has the opportunity to go to a great school, and we are falling far short of that as a Nation. And what school choice is really about is trying to make sure that in an imperfect world, we give every kid a chance. And I believe in school choice, because I trust America's parents. I trust that in the imperfect world we live in, that the best way to figure out what is best for a child is to empower a parent. And Ms. Cherry, I notice the school that you go to is called Tampa Bay Christian, which I would assume has a faith-based component to it. Is that --right?

Mrs. CHERRY. Yes, that is correct.

Mr. MESSER. And one of the things I believe that we all have to understand in modern America today, that we already have school choice if you can afford it. If you can afford to move, if you are in a ZIP Code that has a failing school or if you can afford to pay for another private school option, you have that choice. Would you be able to send your child to a faith-based private school without this program?

Mrs. CHERRY. Absolutely not.

Mr. MESSER. Are you finding that, I would think, an important element of your education experience for your children?

Mrs. CHERRY. Yes. The Step-Up for Students Scholarship and Tampa Bay Christian Academy have been an anchor for my family.

Mr. MESSER. I think, again, when we focus on parents and we focus on families, we just remember why shouldn't everybody have that chance? I don't know that we are ever going to come up with a program that is perfect. We sure weren't perfect before we started trying to find these alternative solutions. But we had parents in many places in America today, let's own it, there's a million people on charter school wait lists around America, parents who want the chance to send the child somewhere else and can't because they can't afford to do it. And it's wrong, and it's long past time that we do something about it in America.

Now Mr. Williams, I would love to give you an opportunity to respond to some of Mr. Scott's comments, but elaborate a little bit on these -- I thought you mentioned at the very beginning, but elaborate a little on this idea that when a parent chooses to go to a school, a private school, that they should be treated like everyone else at that school, but to try to turn every school in America into one uniform bland model, I think, wouldn't provide better opportunities for our kids.

Mr. WILLIAMS. If I could, I would respond to two things: Number one is that a parent is making a fundamental choice, and I would go back to what Ranking Member Polis said at the beginning, obviously, it is extremely important for them to have adequate information.

Mr. MESSER. Yes.

Mr. WILLIAMS. And it is extremely important for them to be able to make a knowing and intelligent decision. If we provide them with that information, and some parents -- and they do it today -- some parents make the decision to take their kid out of a public school, and take that youngster with a disability to a private school today, because private schools today are indeed educating youngsters with disabilities. And they do it understanding that fate is not available to them. They do it understanding that they won't have an IEP, but they say there is something else at that school that -- that is why I want my youngster there. Every parent won't make that decision. And that is the beauty of what you are deciding, what you are working on. Every parent won't make that decision, but some parents do and some parents will.

The other thing is, as I mentioned in my opening remarks, there are 31, I think, there is an indication -- 31 of 33 empirical studies found that choice did improve student outcomes. While I was the commissioner in Texas and not Louisiana, and not fully conversant in the Louisiana study, I realized that was a snapshot in time, that was a study at the beginning of that program, and we expect it to get better results and better scores as it goes along.

Chairman ROKITA. The gentleman's time has expired. The gentleman from Colorado, Ranking Member Polis, is recognized for 5 minutes.

Mr. POLIS. Thank you, Chairman Rokita. You know, I want to point out as we debate this, that over 90 percent of the students in this country go to public schools of some form, so we are obviously spending a lot of time debating that other 8 or 9 percent, but 90 percent of students go to public schools, including magnet schools, and neighborhood schools, and charter schools, and alternative schools, and from all those and many more, there are all sorts of models of public schools from the Montessori Sot, to rigorous college prep, to experiential, to arts-focused. So, you know, it would be nice for the committee to spend at least 90 percent of our time focusing about some of the things that are occurring on the public side, as Mr. Kubacki runs a public school, I'm sure can attest to as well.

I want to hone down on something that Mr. Williams said along the same lines that Mr. Scott asked. I want to give Mr. Williams the opportunity to clarify a statement he made. His words, I fear, might have been a bit misleading with regards to those who are unfamiliar with requirements of the IDEA, because it gets very technical and very legalistic.

Mr. Williams, in your testimony, you stated that if a public school district has made FAPE, Free Appropriate Public Education, available to an IDEA-eligible student, and the student's parents have, instead, chosen to place their child in a private school with a State-funded private school choice scholarship, that child is con-

sidered a parentally placed private school student. That's what you mentioned.

And you also said that student would then have the same IDEA rights as all other IDEA-eligible, parentally placed private school students. So I want to hone down on that and I want to be clear about which IDEA rights parentally placed private school students enjoy.

Parentally placed private school students give up their right to a free and appropriate public education, which we call FAPE and related services, an obligation to provide the services under Federal law. So parents who use a State-funded private school voucher give up their right to FAPE, meaning the school district is not required to pay for FAPE, including things like private placements. And the private school, then, is not required by law to provide any particular special education-related service that would meet the requirements of FAPE, like speech therapy, or assistive technology, or whatever that might be, so long as the student remains in that private school.

The only exception to this would be limited child fine services, perhaps an evaluation to determine IDEA eligibility if the evaluation had not been conducted previously. But Federal IDEA funds, and the right to Free Appropriate Public Education and individual services that come with an IEP, do not follow parentally placed students to private schools. Only when an IEP team determines a private school as the best placement, that's a placement through the school district mechanism, and I will remind you that parents are part of the IEP team, only then do full IDEA funding, and more importantly, rights, follow the student to the private school.

So, Mr. Williams, when a student participates in a State-funded private school voucher program, does he or she maintain the right to FAPE?

Mr. WILLIAMS. She does not.

Mr. POLIS. Thank you. I just wanted to clarify that.

Chairman ROKITA. For the record, Mr. Williams, she does not. Can you use your microphone?

Mr. WILLIAMS. She does not.

Mr. POLIS. I also wanted to quote one other aspect of your testimony back to you. You mentioned, quote, "I am deeply committed to guaranteeing that all students are treated with respect and dignity, and are free from discrimination of their learning environment." How can you make that assurance of schools that don't allow gay or lesbian students to attend, and to the parents of those gay and lesbian students?

Mr. WILLIAMS. I think, first of all, it goes back to what the other protections afforded to those students under current Federal law, and I would suggest to you that whatever the current the Federal law provides those youngsters, those youngsters would be entitled to.

Mr. POLIS. And I would point out to my colleagues, we would welcome their support to extend the protections of Federal law on the basis of sexual orientation and gender identity. And I welcome my friends on the other side of the aisle to join me and Mr. Cicilline in support of the Equality Act, which would do just that.

Ms. Carter, in your testimony, you talked about your own extensive search to find the right school for your son. And you mentioned you considered many kinds of public schools, public charter schools, and other district-run schools. The National Center for Special Education in Charter Schools is taking steps to help advocate for students with disabilities in charters. There is a number of processes around helping parents make the right decision for their child, and in your testimony, you spoke about applying for a charter, but not being selected in the lottery system.

Can you share more about your own decision-making process? And why you personally value school choice and the opportunity to consider multiple schools? And I understand your child is not in the neighborhood school, but is in the school that you found to be most appropriate for your child and with the best program. So if you could talk about how your process for finding the best public school for your child in 20 or 30 seconds, that would be great, and you can submit more later.

Ms. CARTER. Thank you, excuse me, member Polis. Yes, we -- my experience is based on professional and personal advocacy. And in that context, it is about research, investigating what is available. And so, it's important to be able to understand what I am comparing. So I look to the accountability standards that are in place. I chose to stay in the public arena simply because "A," my child has disabilities, as well as the fact that I am a taxpayer, and I am a public school recipient, so I support public education. And—

Chairman ROKITA. The gentleman's time has expired. I'm sorry.

Ms. Bonamici, you are recognized for 5 minutes.

Ms. BONAMICI. Thank you very much, Mr. Chairman, and ranking member, for holding this hearing about school choice. Here is an example of some excellent school choices in the district I am honored to represent. The Beaverton School District has -- in northwest Oregon, has a really diverse student body, more than 100 languages, spoken in student homes. There's an international IB school, a magnet schools focusing on environmental sciences and health careers, science and technology program, an arts and communication magnet, which is where my own daughter went to school. Two of the district public schools have STEAM-focused curriculum. They have two districts reported charter schools with language immersion programs in Spanish and Chinese. There is a community high school, an early college high school with an optional partnership with the community college, and an open enrollment process for students in neighboring districts.

Families in Beaverton district have considerable choice and don't have to sign away their rights to Federal civil rights protections, or give up transparency or student achievement when they make that choice. I wanted to mention, when I listened to the testimony, parents across this country want a school for their children that has high expectations, like Ms. Cherry mentioned. And they want a school that recognizes your student's individual strengths, like Mr. Kubacki mentioned. These are qualities are not exclusive to private or religious or charter schools.

There are great private schools in the district I represent, they are not taking tax dollars from public schools. And as policy-makers, our focus should be on making sure that all schools have

the resources and the support they need to maintain those qualities, and I know that the chairman, in his opening remarks, said parents don't want their children trapped in a failing school. Now people have different definitions of what failing school means, schools are buildings, maybe they are schools where many children are having more challenges. And we as policymakers should be saying, we don't want any failing schools. So that should be our focus to make sure that all students have opportunities.

I wanted to ask you, Ms. Carter, students of color, students with disabilities, LGBTQ students like Mr. Polis was talking about, are really disproportionately affected by suspensions and expulsions. Of course, we don't know the data for voucher programs, because private schools are not required to publicly report that information. So should public dollars be used to fund schools that can discriminate against students? And what safeguards do we need to make sure your son receives a high-quality education as a student who has rights under the IDEA?

Ms. CARTER. Yes, thank you. First of all, no. No school should be able to discriminate. We do have laws in place, and when you are not in a position where you can have access to laws that protect parents and students with disabilities, or different students' rights, then—that—therein lies a problem. And so with IDEA, there are those protections; the FAPE, Free Appropriate Public Education; there's also, in the least restrictive environment, so that we don't have students educated in segregated classrooms which are called self-contained classrooms.

And we also have the notion of due process, where we have access to the law, where we have an opportunity to be heard and given that notice with respect to what the rights are.

Ms. BONAMICI. Thank you. And I want to ask Mr. Williams a question before my time expires. But thank you, thank you very much. Mr. Williams, your testimony didn't discuss the challenges of school choice programs in rural Texas. I represent a lot of rural Oregon, and it is not surprising that rural districts in Texas are some of the strongest opponents of the proposal in Texas to shift public education funding to education savings accounts, because rural communities often have just a single school. It is the community hub that has been serving the student's parents and grandparents, and it's where people gather and there is no other school in that town, or even in a close proximity, so small-town school systems don't have the economies of scale.

So can you explain to my constituents in Oregon's rural areas why they should give up needed funding to a handful of private schools that aren't near their community, especially when these private choice programs have an unproven academic outcomes, and do not serve all students?

Mr. WILLIAMS. I will start initially, because it is going to give those families more choices to acquire the learning that they need for their youngster. We have been having this conversation in Texas and elsewhere, as if it's the only thing we are talking about, is moving a youngster from one building, Thomas Jefferson, to another building, perhaps St. Thomas Aquinas. But in rural Texas, and we haven't won this argument yet, but in rural Texas, with that education savings account, perhaps they can buy Mandarin

Chinese from a distance learner -- distance provider; maybe they can provide -- acquire some kind of math skill because you can't get a master math teacher in "Scatback," Texas, maybe you can buy that from --

Ms. BONAMICI. My time is about to expire. I appreciate that. But we just got our graduation rates back and our online high school had very embarrassing, pathetic graduation rates of 28 percent.

Chairman ROKITA. The gentlewoman's current time has expired.

Ms. BONAMICI. Thank you. I yield back.

Chairman ROKITA. The gentleman from Virginia, Mr. Brat, is recognized for 5 minutes.

Mr. BRAT. Thank you, Chairman. To the panel and Mr. Williams, I'll ask the question. I am an educator. I taught Randolph-Macon College down the road a couple of hours for 18 years, economics and ethics. Went to seminary and then did a Ph.D. in economics, so I am a confused person. So I just got back from the prayer breakfast. Very nice, bipartisan, across-the-aisle stuff. We get along more than the press gives us credit. And so, this can be a contested issue, right? I mean, we have differences in strategy, but one of the things I saw—I taught freshmen—coming into my classroom all the time. And I think one of the things some of us on this side of the aisle consider is just kind of the one-size-fits-all nature sometimes of education. And my public schools are top in the country. So my kids both got excellent education. But nationwide, we are now competing with the rest of the world. We all want the kids to excel, right?

So you can look at the Ps and test scores. I ran regressions on too much of that stuff for too many years, and I won't go into all the details. But the point is we have got kids that don't know what a business is after they graduate from high school. They don't know a price from a cost from a profit. They can't define any of it. Right. And then the kids get to go to college, that's great. But the kids that don't go to college, they don't know what business is, and they are going to work.

So I think we have huge work to do, whatever solutions we all agree on. And then I taught ethics and went to seminary, et cetera, and there is no such thing as just ethics. Right? There is the Aristotelian school of ethics, or Kantian ethics, or Christian ethics, or Confucian ethics. Right? There is no ethics. And what system of ethics are we teaching in K-12? None. The kids come to college, they don't know one system of ethics, they can't name one theologian philosopher, et cetera. So that's why some on this side of the aisle, we just want to see some variety when it comes to the curriculum -- the monopoly model -- it is hard to crack up monopolies, right, in economics, or monopoly in politics, or monopoly in any business that doesn't produce the best outcomes.

So we just want to see some variety. And Bobby and I are in Virginia, we have a tremendous Achievable Dream school that is in the inner city, and has just done unbelievable job, charter school, public charter, and they do phenomenal. Right? The kids are introduced, they walk and meet the police officers, at the beginning of the day, they have stock market gains, they learn about business, they got a tennis program, all the kids go to college and it's phenomenal. And so, we all are trying to find that for all of our kids.

And then getting to my question, right, the political tensions are high. Right after the election, everyone's bombing each other on Facebook right now, and the tone's not good.

So I am trying to keep the tone good. And so, one of the questions I get back home from constituents that have major concerns are, we have some of the best public schools in the country in my area, but we all want to see kids in the poorer areas, and the inner cities have some choice.

I think that is part of the issue that is on people's minds right now. But then the question from constituents is "Well, won't the school choice movement pull funding from public schools?" What would you say to those suburban moms and dads who are concerned and have anxiety that if we move towards choice, that money won't come from their public schools? What is the variety of funding options available that would ease some of the anxiety out there?

Mr. WILLIAMS. Well, depending on how you design it, let us keep in mind that most of the school choice plans that I have seen, that whatever the per capita spending amount is, the voucher, or whatever that is, is less than that, and so there is still going to be sort of the delta that is available for the public schools, and that body is no longer in that school. And so, you are not having to be concerned about that piece, because you don't have to educate the child, and some dollars are still get to remain with the public school.

But I think more importantly, what we ought to be doing, I mean, to my left are three parents that have children with three different sets of needs. And we should be creating opportunities for all of those needs to be satisfied in a public school, public learning environment, and that includes private schools, because everybody can't -- everybody doesn't do the same thing. I mean, all these schools aren't designed to do the same thing. We ought to put parents in the best position to find the school that meets the needs of their child.

Mr. BRAT. That's great. Thank you. I have about 30 seconds. I'll just kind of add, I teach economics, and in economics, you try to maximize utility. And so, there -- everyone is going to debate across the aisle what are the test scores and comparisons, and they'll say they are not that great, we will say they are great. Even if we compromise and say, let's say they are dead even, it seems to me it's kind of analogous to working for a firm. Sometimes you just want to go to work for that firm instead of that firm. Right? There is a tone at the top, you like the CEO, the principal, you like the vice principal. Your kid may be socially stigmatized at one school, they feel better going to another school, et cetera. And so that is my impetus for the school choice option, is I think the kids do need some variety, parents need some variety. I worked for several years at the State level --

Chairman ROKITA. The gentleman's time has expired. The gentlelady from California, Ms. Davis, is recognized for 5 minutes.

Mr. BRAT. Thank you, Chairman. Thank you very much for coming in today.

Mrs. DAVIS. Thank you. Thank you, Mr. Chairman. And thank you to all of you for being here. We know it is a great effort to do

that. Ms. Carter, I wanted to ask you a little bit more about your experience, I know we have had to cut you off. Just -- you had to really navigate a very complex school system as you branched out and looked at everything. Could you talk about one or two instances where you were testing the transparency of the system itself, and access to information for a parent, any parent, but particularly a parent who was interested in the policies that have been enacted at the Federal level for IDEA over the years? How did you learn that? How did you actually get a handle on that?

Ms. CARTER. It was challenging.

Mrs. DAVIS. As a former school board member, I understand that, so --

Ms. CARTER. So it really is searching for opportunities. When I look at my child, and for him, it is about equitable access to a high quality, excellent education. And so, it is understanding who the players are, kind of learning about -- being clear on what my child's needs are, and then searching for those opportunities that can best meet my child's needs.

Mrs. DAVIS. Did you have a sense that the school did a good job in making sure that they had data -- they had backup information, so they could even describe to you how services for, say, another child, not by name, but just generally, how they really demonstrated that they were doing what you were hoping they would do?

Ms. CARTER. The short answer is no. It's about having -- getting access to information. And admittedly, I am a parent who has time, who has information available to me, so it still is a pushing, pushing, pushing from the school. And so one of the things that I focus on is trying to expose and make available, not just to Jacob, but to all students, and particularly those with disabilities, asking questions, pushing. So it is not something that just happened.

Mrs. DAVIS. I wanted to just let you know, because I am concerned about this, and I think others are as well. There was a recent development last evening where my colleagues actually filed the need to move forward to take away some of the important protections that children have, which would basically say to States, you don't have to file -- follow really any guidelines in tracing the improvement, and tracing the performance of young people in schools. Would that concern you that perhaps we're moving away from that, so that States might really be doing this very differently? If you were to move, for example, you might move to a State that had decided they weren't going to follow up with--

Ms. CARTER. That would be a--

Mrs. DAVIS. Understanding how we disaggregate data, whether children of color, whether children who -- where we must adhere to IDEA would be followed?

Ms. CARTER. No. Accountability is key. And so something like that, if that didn't exist, then there wouldn't be a way to even measure whether or not there is equitable access, or even a high-quality education. So these regulations are critical as it relates to a high quality education --

Mrs. DAVIS. Yeah. Could I ask the rest of you? Would that be your concern, or do you think it is important that States have guidelines to follow, to be sure that they're -- making sure that all

children are receiving a high-quality education? We disaggregate that data and we know what is going on?

Mr. WILLIAMS. I think it is important for us as States to have some guidance. But I will be honest with you, in many areas, let's say academic accountability, some of us were there before the national government was, and I think some of us were designing assessments and accountability regimes beforehand. Obviously, No Child Left Behind was birthed somewhere else and came here. So in some of these matters, I think the States are in very good stead to be able to protect our citizens, and do so in a way, that is quite laudatory. But there was no doubt that having the participation, and maybe even the leadership and the guidance of the national government would be helpful at times.

Mrs. DAVIS. Anybody else want to comment on that?

Thank you, thank you, Mr. Chairman.

Chairman ROKITA. I thank the gentlelady for yielding. The gentleman from Arizona, Mr. Grijalva, is recognized for 5 minutes.

Mr. GRIJALVA. Thank you, Mr. Chairman. Like Ms. Davis, my colleague, I served on a school board back home in Tucson for 12 years, and I think my question kind of goes to another part of this whole discussion, it is a discussion of how much of the Federal dollar, public dollar that goes to public education is going to be diverted or sent a different direction in terms of vouchers, for profits, private.

In that position, we had to deal with mandated issues like IDEA, mandated, and necessary, by the way. Civil rights protections, equal access for all children, Title IX so that boys and girls got the same opportunities at all levels, and English learners.

Laws that controlled what we did, open meeting laws, financial disclosure in terms of the budget and the audits attended to that particular school district, and the list goes on. And the public scrutiny that had to be there in order for a school district to be functional.

My question is, as we go forward, there are two standards that seem to appear: there is the standard on public education in terms of the points I just outlined plus more, and a kind of nebulous standard as to what we do for private, for-profit charters that is different. Is there -- and I will ask Mr. Kubacki and Mr. Williams for a response -- don't you feel that the reaction to, I think, the proposition that many of us have, that people should play by the same rules, that if on the governance of a private for-profit; that there should be transparency, there should be rules that apply to the financials; there should be disclosure of salaries; there should be academic disclosures; and the list goes on, and that all children coming need to be taken in, given the mandates that the public schools have. Do you feel that would -- do you think that is fair to set the same playing field for everybody -- Mr. Williams, Mr. Kubacki, either one.

Mr. WILLIAMS. I think that is a fair aspirational goal, but I do not believe that is the law you established here. The law you established here first of all you haven't exercised jurisdiction over private schools generally, and here you have exercised jurisdiction in title VI and title IX--

Mr. GRIJALVA. Yeah but--

Mr. WILLIAMS. And IDEA as relates to --

Mr. GRIJALVA. But Mr. Williams, we are talking about extending that jurisdiction, you know, if we are talking about the increased prominence of private schools in terms of the support they are going to get from the Federal Government in terms of money. Should requirements follow the money or should it be open-ended?

Mr. WILLIAMS. The recipient of those dollars is not that private school. The recipient of that dollar is the mother, or the father, the parent, the guardian, and you haven't exercised jurisdiction over that individual.

Mr. GRIJALVA. And as you said, the final arbiter, the ultimate is the empowerment of that parent, okay. And—but as a balance, as a check and balance, shouldn't some requirements, at the minimum, financial disclosure be required? Investment strategies, open meetings? So we know when these schools meet and who is governing them? And what decisions they are making—at the very minimum shouldn't that be a public acknowledgment as opposed to an individual parent acknowledgement? We are not eliminating that parent's choice, we are just saying the rest of us that are helping pay the bill should know what is going on.

Mr. WILLIAMS. You want to have—sort of get to the right balance between those issues. But I think we have got to be real careful about treating that private school as if it is a public school. So is there—

Mr. GRIJALVA. Given what the nominee for Secretary of Education and her opposition to any reasonable regulation for charter schools or for-profit schools, is there a Federal role in insuring that taxpayer funds are not being abused? Is there?

Mr. WILLIAMS. That is a conversation for you to have here, and there will be some role, of course. The question is how much of a role, and how do we reach the right balance of allowing that private school to function and to adequately serve those youngsters that come to it.

Mr. GRIJALVA. Thank you. And I am broaching that conversation. I appreciate it.

Yield back.

Chairman ROKITA. The gentleman yields back.

The gentleman from Virginia, Mr. Garrett's, recognized for 5 minutes.

Mr. GARRETT. Thank you, Mr. Chairman.

So I think the metric that matters here isn't what day of the week these schools meet, it's not how long they meet. The metric is student success, right? And so, ultimately, I want to introduce myself to this committee and this subcommittee, and I'll tell you that I believe in the nature versus nurture argument, in nurture. I believe in nurture. I believe that no child, regardless of their national origin, regardless of their skin color, regardless of their parents' socioeconomic status or educational attainment, is more able to succeed or fail than another, but that if the child is placed in a circumstance where the child can succeed and encouraged and given appropriate instruction, that the child will in all likelihood succeed.

And I believe that there is a fundamental entitlement that Americans can expect, one fundamental entitlement, and that is oppor-

tunity. And I see children being left behind every single day by virtue of circumstances beyond their control, and that is a ZIP Code; that's a parent who loves their child no differently than I love my own, but who doesn't have the financial wherewithal to place themselves in the circumstance where they can assure their children the best educational opportunity.

And we had this fight again and again during my time in the State legislature, and there, one party said, look, we have really good public schools except for where we don't, and we need to ensure that the young people in those areas also have an opportunity. Are the children failing those schools? No. The schools are failing the children. I understand there's a plethora of inputs: socio-economic status, educational attainment of parents, et cetera, et cetera, so forth and so on. But if we know to a metaphysical certainty that in one ZIP Code schools are failing, then shouldn't we change how we do business?

So I would, Mr. Chairman, direct my questions at this juncture to Ms. Cherry.

Ms. Cherry, you were, in fact -- your children were in public school in Pasco County.

Mrs. CHERRY. Yes, sir.

Mr. GARRETT. And you were happy, very happy with the outcomes that your children were seeing in Pasco County, your husband Demetrius and yourself?

Mrs. CHERRY. That is correct.

Mr. GARRETT. And we've heard conjecture that people might flee public schools if these opportunities are made available, but you only left those public schools in Pasco County after financial calamity, beyond your control, struck your family. Am I correct?

Mrs. CHERRY. That is correct.

Mr. GARRETT. Okay. You would have remained in those schools with which you were happy.

Mrs. CHERRY. That is correct.

Mr. GARRETT. And so had Florida not had a system wherein, I believe, what, 79,000 young people received scholarship opportunities, your children would be in school where?

Mrs. CHERRY. I'm not sure, because when it was time to enroll, we didn't have a permanent address, so I'm really not sure.

Mr. GARRETT. But, ultimately, you ended up at Tampa Bay Christian.

Mrs. CHERRY. Correct.

Mr. GARRETT. Do you feel that the educational opportunities afforded to your -- was it three or four children?

Mrs. CHERRY. There's four.

Mr. GARRETT. -- four children at Tampa Bay Christian are sufficient for them to be able to live successful lives here in the United States of America?

Mrs. CHERRY. Yes, definitely.

Mr. GARRETT. Okay. And this was made possible because somebody in Florida decided to break from the status quo and think outside the box.

Mrs. CHERRY. Yes, sir.

Mr. GARRETT. Okay. And so if somebody hadn't, can you say with any certainty whatsoever that your children would be receiving

what I would argue they're entitled to, which is the opportunity provided by a solid education?

Mrs. CHERRY. I couldn't say that.

Mr. GARRETT. Okay. Thank you.

And -- I talk too fast. Mr. Williams, I would move my questioning to you. Ultimately, we look a lot at per-pupil expenditures. And what I've seen from the studies that I've reviewed in my previous legislative experience, a much smaller format, was that the per-pupil expenditure does not decrease commensurate to the number of individuals who leave a school. In essence that, if we're funding a particular school to the tune of \$12,000 per pupil and a pupil leaves, that only a percentage of that funding leaves with that pupil. Is that accurate?

Mr. WILLIAMS. That is true. The only thing that changes is the number of students that the school has.

Mr. GARRETT. So, but, if the average per-pupil expenditure is \$12,000, then let's say that \$6,000 follows the student, the money follows the child, then that leaves a surplus at the school from whence the child came, in most instances. Is that correct?

Mr. WILLIAMS. Correct.

Mr. GARRETT. And so, ultimately, now what we have is, if resources are the question, a greater number of resources per pupil as that child is subtracted from the total number of children in the school.

Mr. WILLIAMS. Quite possible.

Mr. GARRETT. And so, if you could help me, because I'm completely missing something here, what would the argument against having a greater per-pupil resource base at what had -- some parent might have identified as a school not providing their child an opportunity, what would the argument against that greater per-pupil resource base be? I'm missing it.

Mr. WILLIAMS. I can't help you much with that. What I think it's just simply a fundamental philosophical difference in allowing folks to move to private schools.

Mr. GARRETT. And so, Mr. Chairman, I've got about 15 seconds. Ultimately, though, I'd ask Mr. Kubacki, and I apologize if I'm pronouncing your name wrong, should the goal not be that every child receives the education they need to have the potential to succeed in this Nation?

Mr. KUBACKI. Yes.

Mr. GARRETT. Thank you.

Chairman ROKITA. Wonderful. Yes or no question. The gentleman's time's expired. I thank the gentleman.

My friend, the former ranking member of the subcommittee, Mrs. Fudge, you're recognized for 5 minutes.

Ms. FUDGE. Thank you very much, Mr. Chairman. And I thank you all so much for being here today.

Let me just make two comments, the one that my colleague just made about he couldn't understand why people are concerned about a student leaving if they retain a certain amount of the money. It's just basic math. Schools are based upon the number of kids they project are going to be there. So you still have to pay all the bills, you have to pay all the teachers. If you lose a student, it makes a difference.

And as well, Mr. Chairman, I think maybe there comes a point where we need to raise our hands up here too about telling the truth. My colleague, Mr. Messer, made a blanket statement about our ranking member saying that he was not correct, but, in fact, Mr. Messer had no basis in fact for making the statement.

Let me just be clear with you. I'm from the State of Ohio. We have an EdChoice voucher program. A study by the voucher people indicated last year that students who participated in that program did considerably worse than similar students in the public schools. So, in fact, there is indeed a legitimate decline in achievement in some of these programs. So I just wanted to make clear to Mr. Messer that, in fact, is the case.

Ms. Carter, school voucher proponents do not believe that private K-12 schools receiving publicly-funded vouchers should follow the same rules as public recipients of federal funding. For example, the nominee for education secretary, Ms. DeVos, refused to say that all schools receiving federal aid should be held to the same accountability standards, including IDEA, which I don't think she even knew what it was.

Could you elaborate on your assertion that all schools should be held to the same accountability standards and safeguards?

Ms. CARTER. Yes. Thank you. So with respect to the same standards, that accountability and transparency is something that can also be measured. And the standardization of that allows for families to make an informed choice, because choice is a good thing, but it's about having an informed choice so that you know that your child has an equitable access to that high-quality education. So targeted professional development, training of all the teachers and educators that are going to be working with students is critical to have that equity, if you will, and to have a measure that supports the delivery of a high quality education.

In addition to that, noting that it's an individualized notion, it's based on the needs of that individual student, and when you have standardization as it relates to transparency and accountability, those safeguards, then again, you have something with which to measure, to compare, and analyze.

Ms. FUDGE. Thank you. To you as well, Ms. Carter. We've repeatedly heard that the argument that private school choice programs provide parents with the opportunity to select the best school for their children. When describing your search for quality education options, you stated, the panoply of choice, this is your words, was narrowed and, in fact, not a viable choice for your son. Please explain how your choices were limited in your search because of his disability.

Ms. CARTER. Yes. So with respect to a high quality education, what's important for Jacob was the fact that teachers, again, were trained, they had an understanding of what his disabilities are, what the requirements are, and that's what IDEA does under FAPE and least restrictive environment. So I had confidence that I had an understanding, but I also had something with which to measure whether or not the particular choices had that.

And when you're looking at private placements, and not through the public school system, but private placements, they don't have anything near what would be appropriate for Jacob in terms of pro-

viding those related services that he needs, the specialized instruction that he needs.

And so, again, our focus was on the public system, because there are safeguards in place whereby I can go and see and count on there being accountability associated with what those services are.

Ms. FUDGE. Thank you very much.

And I would just say to this committee, I am not an opponent of charter schools, I am not an opponent of vouchers; I am a proponent of public schools. Ninety-plus percent of the children I represent go to public schools. So I need to be sure that someone is looking out for the 90-plus percent as well as the 8 to 10 percent.

And with that, Mr. Chairman, I would yield back.

Chairman ROKITA. The gentlelady yields back.

Ms. Adams from North Carolina, you're recognized for 5 minutes.

Ms. ADAMS. Thank you, Chairman Rokita and Ranking Member Polis, for allowing me to visit this subcommittee. I do want to thank our panelists for their testimonies.

And like many of you, the importance of education is personal to me. I'm a parent, grandparent, I'm also an educator by training. Forty years, four decades I spent as a professor at Bennett College in North Carolina preparing students, many of whom have gone on to be teachers across the country. So -- and it's clear that from the nomination of Betsy DeVos for Secretary of Education that it appears that the administration intends to push a private school choice agenda that will, I believe, undermine public education.

Having said that, Ms. Carter, I want to thank you for sharing your experience with us today. Fifty million students who make up, as has just been said, 90 percent of America's school children attend public schools. All of my children and grandchildren attended public schools. And so the choice taxpayer funds that would otherwise go to public schools serving the vast majority of our students, it diverts them to private schools.

Ms. Carter, you spoke about your strong sense of duty and advocacy on behalf of your son, Jacob. Can you speak a little bit to the amount of time that it took to navigate the school system, how your journey might have been impacted if you knew you had a high quality public school in your neighborhood?

Ms. CARTER. Yes. If there was a high quality school in my neighborhood, it certainly would have relieved some of the anxiety and stress that has gone into the process. And at least it's something that would be accessible, and, again, not just to Jacob, but what's available in the community, that individualized notion that has a place, a centralized place where Jacob has a chance, a real chance to be successful and to have access to that high quality education.

Ms. ADAMS. Okay. The Every Student Succeeds Act requires States to develop and implement challenging academic standards to ensure that students are career ready or college prepared, standards that apply to all students, except for students with the most significant cognitive abilities who are assessed on the easier alternate assessment. Private schools such as those used in many voucher programs are not required to abide by ESSA. They do not have to set standards, assess students to ensure that they're college and career ready, or provide information about academic achievement to parents.

Ms. Carter, you mentioned that your son is included in the general education classroom with peers of his same age. How important is it for students with disabilities to be held to these standards, and can you describe how this has helped Jacob to be successful in school?

Ms. CARTER. Yes. First of all, high expectations, those standards that are in place -- I have high expectations of Jacob. I think we as parents all have high expectations of our children to be successful. And communicating those high expectations is critical, because when you set the tone and you -- school systems understand that not only are parents taking their responsibility seriously, but it's the fact that you are helping to promote those high quality standards.

Jacob is going to college, and it's a particular thing that I spend a lot of energy speaking to all the schools, the administrators, the educators, kind of that same thing. Jacob is going to college. And as a result of that, I have to make sure that he is appropriately prepared to be successful in college.

Ms. ADAMS. Thank you.

Mrs. Cherry, did anyone inform you of your right under Federal law to keep your kids enrolled in their home school when your family experienced homelessness?

Mrs. CHERRY. I actually went to the school and told them that I was moving. So I had to -- I was actually told that I was zoned out of the school. There's a process that you had to go through to get back in, but with the time -- I didn't have time to do that, so that's why I had to choose.

Ms. ADAMS. So were you informed, though, that you could have kept --

Mrs. CHERRY. No, I was not. They never told me that.

Ms. ADAMS. Well, that's the problem. I think parents do not have the necessary information that they need.

I just wanted to quickly ask Mr. Williams, you know, you pointed out that many voucher programs don't test at all, others use tests differently. How are you able to approve the impact on student achievement and hold schools accountable?

Mr. WILLIAMS. I think what you could do here is to direct us as the SEAs that design accountability programs that would require some level of testing. And I think most private schools would be more than happy to use our basic test or use their ACT or SAT for high schoolers.

What I said in my opening remarks is that our accountability system that we use today, and I think that of the other 49 states, would not neatly fit on top of private schools. That, I would discourage us to do, is to say that the exact accountability system that I have now for my public schools and traditional charters, that we apply that directly to the private schools.

Ms. ADAMS. Thank you, sir. I'm out of time.

Chairman ROKITA. The gentleman's time has expired. I thank the gentlelady.

Mr. Takano, you're recognized for 5 minutes.

Mr. TAKANO. Thank you, Mr. Chairman.

Betsy DeVos, the nominee for Secretary of Education has advocated for a lack of oversight and regulation in Michigan's charter

school law. As a result, it has 33 for-profit organizations that run 79 percent of the State's charter schools. Detroit, overwhelmed by bad choices for children, produced the worst math and reading results among all U.S. cities.

In my own district, I have a constituent, Sarah Vigrass, who works for California Virtual Academies, managed by K12 Incorporated, a for-profit education company supported by Ms. DeVos and her family. In her 10 years there, Sarah has seen firsthand the decline in amount and quality of materials and high teacher turnover rates driven by K12 Incorporated, maximizing their profits and not investing in students.

My question is for Ms. Carter. Ms. Carter, do you believe for-profit entities can serve their bottom line as well as their students effectively?

Ms. CARTER. No, I do not.

Mr. TAKANO. And why was a for-profit charter school not the best option for your son?

Ms. CARTER. As it relates to Jacob, because he has disabilities, it's about individual needs, what his needs are. And in inquiring these for-profit entities, I discovered that they could not tell me what they were going to be able to do to support what his needs are. And the fact that there aren't standards or there's no accountability as it relates to what children with disabilities need, and all children, for that matter, that didn't make me comfortable.

Mr. TAKANO. Well, it's interesting that the -- I think we have a public interest in making sure that schools, this idea of competition and accountability that exists among schools, but we're not the -- we're totally leaving that out of the picture in terms of Federal money being used for these schools.

The Department of Education collects extensive data on public schools, including achievement, enrollment, discipline, bullying, harassment, and special education information. These data collection procedures provide transparency to stakeholders and allow for the Department and State educational agencies to intervene, if necessary, to reduce and prevent discriminatory practices. Private schools are not required to report the same information, even if they accept vouchers in most States.

Ms. Carter, in your testimony, you said you researched and became very informed about public school choice options in D.C. Do you feel the transparency of schools about their academic outcomes, discipline practices, and special educational services are important in determining the best education for your son?

Ms. CARTER. Yes, I do. And I do because diversity is critical, diversity in terms of what kinds of students are made up in the environment, as well as the opportunity for all children to succeed. Inclusion is critically important. And so knowing that information is a part of the process of determining whether or not this particular school choice is what would be best for my child.

Mr. TAKANO. In your opinion, what other information is critical in ensuring your son receives a high quality education?

Ms. CARTER. Knowing the background and the training and the credentials associated with the educators who are going to be providing that kind of support and services to my child; in addition to the related services, speech, occupational therapy, physical ther-

apy, those kinds of related services that my child needs; knowing what those credentials are so that I can evaluate whether or not I feel that this is a good choice for my child to be successful.

Mr. TAKANO. And you're telling me that information wasn't always available to you?

Ms. CARTER. Not in a for-profit environment, no.

Mr. TAKANO. That's interesting.

Mr. Williams, it's come to light that several Trump appointees to serve in leadership roles at the U.S. Department of Education have a history of expressing bigoted comments. These appointees have made blatantly racist, Islamophobic, transphobic, and homophobic remarks.

Now, as the former head of the Office of Civil Rights at the Education Department, is it appropriate to have individuals like this at the helm of ensuring educational equity and nondiscrimination based on race, religion, and sexual orientation?

Mr. WILLIAMS. Mr. Takano, without accepting the beginning of your question that they have indeed made such comments, let me go to what I think is the thrust.

Mr. TAKANO. I'm just asking you, sir --

Mr. WILLIAMS. Let me go to the thrust.

Mr. TAKANO. No, no. These appointees have also -- look, is it appropriate for anyone who's made blatant racist, Islamophobic, transphobic, and homophobic remarks to serve in these capacities, whose job it is to ensure that there's educational equity and nondiscrimination? Would you -- would you countenance --

Mr. WILLIAMS. I would love to have an opportunity to answer the question.

Mr. TAKANO. Sure.

Chairman ROKITA. The gentleman's time has expired.

Mr. Allen, you're recognized for 5 minutes.

Mr. ALLEN. Yes. Thank you, Mr. Chairman, and thank you for having this hearing today.

The best example that I know of school choice is a school that we developed in my district called Heritage Academy. And that school is there for those single parents who can't afford to send their children to a private school. And through some tax initiatives in the State, business people are able to support these children. Now we're up to 200 students. And I attended an assembly there over the holidays, and I have not seen the energy to learn and to develop musical skills and athletic skills and reading skills, I've not seen that anywhere in any school that I think I've ever visited.

And so, again, these are single parents who -- and unfortunately, there is a huge demand for this school that we can't meet. I mean, it's -- we're topped out at 200. In many cases, these kids are actually told that they really don't belong in the public school system, and the parents don't have a choice. So that is a tremendous success story and why I believe that the American people, just like health care, they want choice. I mean, don't mandate and don't waste my taxpayers' money, you know.

And so, with that, Mr. Williams, what is your reaction to the anti-school choice advocates who argue that we should not give families more choice, because too few of the students can benefit,

and then argue for and actively pursue barriers to expand those benefits to more students?

Mr. WILLIAMS. Well, I'm saddened by it, quite frankly, because what we ought to be doing, as I've said before, is that we should be doing our best to find in a way that we can match youngsters and their particular needs. And youngsters have a variety of different needs. With our 5.2 million youngsters in Texas, I'm not going to say we have 5.2 different kinds of needs, but we've got a wide variety of them. And what we should be trying to do is to put parents and guardians in the position to match needs with schools. Kids are very, very different. And the public schools in Texas, I think, do an outstanding job of trying to satisfy the needs of those youngsters, but that doesn't mean there's not another place in the private school community for us to satisfy those needs as well. There's enough room and there's enough demand, there's enough challenge for both traditional public schools and charters and private schools to be present to provide opportunity for our students.

And going back to something that was asked of me earlier, you know, at the end of the day, we haven't seen -- in terms of school choice programs around the country, we haven't seen exit rates, you know, greater than 8, 9, 10 percent. At the end of the day, I would still have almost 5 million kids in Texas public schools. And so we have to be focused on enhancing public schools while we give parents and guardians the opportunity that, if they don't want or choose -- want to make a decision for their kids not to go to a traditional public school, to find a school that meets that kid's needs somewhere else.

Mr. ALLEN. And thank you so much for that response. In fact, we have a public school, inner city school system in my district in Lawrence County in the city of Dublin where they have a STEM school and also kind of an economic school in the two elementary schools. And parents were there at 5 o'clock in the morning on a Saturday morning to sign their kids up for one school or the other. That's what I'm talking about. That motivates and that is school choice, and it's wonderful.

I have just a short period of time. Mr. Kuback -- Kuback --

Mr. KUBACKI. Kubacki.

Mr. ALLEN. Kuback. Okay. The purpose of school choice is to provide parents the opportunity to find the right educational environment for their child. Do you believe charter schools are the only way to help parents find the right place?

Mr. KUBACKI. No.

Mr. ALLEN. Isn't it important to have a variety of options for parents to choose from where they're searching for the right replacement?

Mr. KUBACKI. Yes.

Mr. ALLEN. What are some things that can be done to ensure parents have access to the choices they want?

Mr. KUBACKI. One of the really effective things that we've started in Indianapolis is our Enroll Indy program, where it is -- it's an open enrollment program for parents to be able to, they have one place where they can go, they can see the variety of options that are available to them. It's one application for them to fill out. And

it makes it a little bit more of an equitable process for all parents to be able to see their options and choose in an intelligent way.

Mr. ALLEN. Thank you. I yield back.

Chairman ROKITA. Mr. Courtney, you're recognized for 5 minutes.

Mr. COURTNEY. Thank you, Mr. Chairman, for letting me visit for a few minutes here.

And, you know, again, we all have great stories to tell, the States that we come from. I come from Connecticut, and I just visited a Blue Ribbon school a couple of weeks ago, which is an old-fashioned red brick public school with a, you know, the locally enrolled kids that are there. It also happens to be a population that is kids whose parents work at the Groton Navy base. It's the oldest submarine base in our Nation.

And when you talk about challenges, these are kids whose parents are -- whose fathers largely, but now women are coming on as part of the submarine force, are deployed and, you know, very transitory, in and out. I mean, that is a challenge for the school. But with all of the requirements to honor IDEA, you know, all the anti-bullying, all the other accountability measures, they are still just hitting it out of the ballpark in terms of scores, in terms of math and reading, and has, again, been recognized nationally in terms of -- so, you know, I think it's really -- there's a narrative out there that, you know, public schools are hopeless.

And, you know, visiting that school, you know, a week or so ago after they got the Blue Ribbon designation, I mean, the fact of the matter is that good leadership, teamwork, involving parents, you know, there are public schools that are doing an outstanding job out there, and, you know, that's, you know, where the 90 percent of kids are enrolled these days.

Also in Connecticut, since the court ruling came out, *Sheff v. O'Neill*, we've employed a magnet school approach to try and break down racial isolation, because, as Ms. Carter eloquently stated, you know, trying to, you know, have kids learn in a more diverse classroom is, I think, something that the Supreme Court recognized in *Brown v. Education*, and I think most thoughtful educators agree is a positive goal.

The charter school track record in terms of that issue of racial isolation, frankly, is just far inferior to the magnet school experience. The city of New London, which is one of the most distressed municipalities in the State of Connecticut now, is all magnet, and they're drawing kids in from communities outside of the city limits. They have, again, focuses, because we're upgrading the submarine force, we're hiring now in terms of the STEM curriculum, and that with the magnet focus, they are actually opening doors to both diversity and quality and a connection to workforce needs that is, I think, you know, one of the models for how we sort of move forward as a Nation, but we don't do it by throwing out accountability. These magnet schools are public budgets that have to, again, pass muster through all of the process that the boards of education have to do with their schools, unlike vouchers, which are basically just disconnected from accountability.

And, Mr. Chairman, I just wanted to add to the record an article which, again, describes the magnet school experience in the State of Connecticut, I ask unanimous consent to have it entered.

Chairman ROKITA. Without objection.

[The information follows:]



Educational investment that works and is affordable

Published October 16, 2016 12:01AM

Art Arpin

For the past four years, the Marine Science Magnet High School (MSMHS) of Southeastern Connecticut received an average of 400 applications for its incoming freshman class. Like every magnet school in Connecticut, it used a lottery process to randomly select the 73 students who get in.

With demand so high that less than 20 percent of applicants gain entrance, one would think that the Connecticut state legislature would increase magnet school funding so that more families in Groton and elsewhere in the state could access the educational choices they want. Instead, the legislature has frozen magnet school funding.

Consider Angela (for privacy I used only her first name). She wants to be a doctor, not a marine biologist, but she still attended MSMHS because it provides a school environment that helped her learn about people and the world around her. The daughter of immigrants, she won't just be the first in her family to attend medical school, this month she became the first in her family to attend college — and her high school inspired her to chase after her dreams.

MSMHS is not the only magnet school that serves its students well. In 2012, the State Department of Education in Connecticut reported that students in Hartford who attended magnet schools did better than those in more traditional neighborhood schools. And the diversity in the magnet schools was terrific: equal numbers of whites, blacks, and Latinos, as opposed to neighborhood schools that were almost two-thirds white.

It's no wonder that the waiting list for magnet schools in Hartford has more than 15,000 students, almost four times the number of seats available.

Last week, the U.S. Department of Education announced funding for four new magnet schools in New Haven. Three will teach science, technology, engineering and math through real-world examples, and the fourth will focus on the social sciences. Only nine school districts received funding this year; New Haven was included because of Connecticut's success with the magnet model.

And yet, the state has placed a moratorium on new magnet school funding.

State lawmakers are concerned that the students not attending magnet schools were being left behind, but their solution — to stop, instead of expand, the innovative programming that delivered results — was both a real head-scratcher and the target of lawsuits. It ran contrary to the trends that federal experts saw in analyzing national data.

At the end of the summer, state Superior Court Judge Thomas Monkawsher ruled that the state government and legislature had to reconfigure how educational funding is distributed. Parents and educational experts alike all call for more magnets to be a main part of the new plan.

Magnet schools were originally conceived of as a response to the U.S. Supreme Court's *Brown v. Board of Education* decision. By focusing on an educational theme, magnets attract a wide range of students from different backgrounds and neighborhoods. Today nearly 4,000 magnet schools nationwide serve over 2 million students.

The primary impetus for magnet schools in Connecticut came from the *Sheff v. O'Neill* state Supreme Court decision, in which the court ruled that students did not receive equal educational opportunities. In response, the state started funding magnets because they were a proven solution. The argument now is that the state should use this magnet school funding to improve its failing schools and forget about integration. But the two problems cannot be separated so easily; they are intertwined.

We cannot rely on the federal budget process to meet the demand for quality education. Instead of cutting funding for magnet schools here in Connecticut, we should fund the current schools at an appropriate level, keeping the state's promise to families. We should then follow with a thoughtful plan to expand the opportunities for students.

This is exactly what innovative school districts are doing across the country. The Miami-Dade County Public School System, for example, is moving to an all-choice model, where all students have options beyond neighborhood geography.

2/6/2017

The Day - Educational investment that works and is affordable - News from southeastern Connecticut

If we are concerned about educating our children, we need to look at someplace other than our education system for budget savings. Our schools are not a piggy bank to shatter when times get tough, but are instead an investment in our future at all times. And magnets are a blue-ribbon investment yielding the highest dividends. It's time to be smarter with our education priorities.

Art Arpin is the regional director of Magnet Schools of America. He is the former principal of the Connecticut IB Academy (CIBA) in East Hartford. He also served as an assistant principal at Hamden High School and Seymour High School, and taught Spanish in the Connecticut towns of Colchester and Milford.

Mr. COURTNEY. And, again, just the New York Times actually did an analysis of Connecticut's experience with magnet school's policy a couple of decades ago compared to the charter school experience in the city of New York. And what they found is that the goal of diversity has been, again, far more successful with the magnet school approach, again, with no cherry-picking in terms of what kids can go there.

My daughter went to one of these. It was a life-changing experience for her in terms of just having the opportunity to interact with kids from different walks of life that would not have happened in, you know, in a charter necessarily or the local public school. And, again, there's just no question in terms of where the value is as far as achieving those goals.

So it's not a binary choice here. It is not vouchers versus public schools. And, frankly, I am still a believer that we can improve education for kids through the old-fashioned way, like the Charles Barnum School in Groton, Connecticut, and that we can also have a publicly accountable system of attracting kids from more diverse backgrounds without just basically throwing money up in the air and hoping it lands in the right place.

And with that, I yield back.

Chairman ROKITA. I thank the gentleman.

I'm going to recognize myself for 5 minutes to ask some questions. Again, I appreciate hearing from the witnesses.

I want to start with you, Mr. Williams. Your testimony talks about the changing behavior of public schools once there was competition, for lack of a better word, I guess. And it's been my observation, you know, I've probably been to 100 schools throughout the country, public, private, good, bad, everything in between, but it would also be my observation, because competition is part of human nature, you know, competition works in politics, competition works on a basketball court, competition works in nearly every facet of our life, yet we heard this morning from some of the questioners that they would seem to be desperately afraid of competition.

When you said behavior was changed or the performance of neighborhood public schools changed, can you give me some specifics about what you're talking about?

Mr. WILLIAMS. I think in many ways imitation is the highest form of flattery. What we have seen -- in my experience from both as commissioner as well as the president of a Catholic school board, what we've noticed is that the public schools, let's say, around us at our Mother of Mercy, the public schools around us, they started extending the hour, the school hour, because we started extending the school hour and getting better results. We started having a different kind of parent-teacher meeting with our parents where we were giving them more and more information about how well their youngsters were doing and what we were going to plan for them in the next session or next semester, and our public schools around us began doing that.

What we see sort of statewide is that we see the offerings of public schools expand. You now have a charter school, quite frankly, which is a public school, the charter school now offering Mandarin Chinese. And now we see other public schools who are trying to do

similar things because they realize that's what parents really -- some parents really want that.

So in terms of offerings, in terms of how the school relates to the parents, in terms of sort of how the school operates day by day in terms of perhaps its hours, perhaps what it does on the weekends, those kinds of things I've seen that --

Chairman ROKITA. Have you noticed increased performance of the neighborhood public school since the introduction of --

Mr. WILLIAMS. In that one, I cannot say that the performance of the --

Chairman ROKITA. You can't --

Mr. WILLIAMS. -- surrounding the public schools and the doughnut around it increased significantly. In large part, I can't say that. At that time, I was not commissioner and I did not have access to their scores.

Chairman ROKITA. Yeah. So you just don't know? It's not that it didn't happen?

Mr. WILLIAMS. Right.

Chairman ROKITA. Thank you, Mr. Williams.

Now, Mr. Kubacki, your testimony is slightly different, not necessarily contradictory, but different in the sense that you rely heavily on your relationship with the public school, local public school district, in order to claim rightfully your success. Critics of school choice, you know, talk about -- they don't use the word "competition," they would use a term like, quote, "pitted against," unquote.

What do you think of the concept of competition as it relates to your work and your relationship with the public school system?

Mr. KUBACKI. So I don't see it as an either/or choice. I see that we collaborate with the public schools and are able to actually work with them to bring our model into even some of their own most academically challenged schools. I think if you look at the environment around Enlace when we first started, the schools that were around that neighborhood, it was kind of hit or miss whether or not it was a good school. Now, 4 years into it, all the schools around us have increased. I wouldn't be so bold as to suggest that we were the only driver behind that, but I would say that because we've been there and are a good neighbor, we do collaborate with the schools around us, we do share best practices. I think it just has helped with the general academic environment of the neighborhood.

Chairman ROKITA. Okay. Thank you. I'm sticking with you, Mr. Kubacki, your testimony discussed your second school, in Kindezi school, opened because the district came to you to restart one of their failing schools. You said that happened because of the partnership your school had with the district schools. Expound on that partnership just a little bit.

Mr. KUBACKI. Sure. So in Indianapolis, we have legislation that allows the district to work with 501(c)(3)s to partner in what's called the Innovation Network Schools. And so it's symbiotic in that we have access to some of the district resources, the most important being facility, and the district then gets our accountability scores as well. So it's a payoff, and it's granted an added layer of accountability for our schools, because we are also accountable to our contract with the district, but I think it lends towards that idea

of we share the collective responsibility for all of the children. And if something's working really well in a charter school, then it's something that would be worth bringing into the public school district.

Chairman ROKITA. Thank you. And I have questions for the other two witnesses as well, but I'd be hypocritical if I let myself go on, because, as you can see, we're now 14 seconds over time. So I want to thank the witnesses again for their testimony.

And I want to recognize the ranking member for his closing remarks.

Mr. POLIS. Well, thank you. I want to thank our witnesses, and I join Chairman Rokita in that. I want to thank our members on both sides of the aisle who joined us. Based on attendance, it's clearly a topic that's important.

Mr. Allen did reference people who are anti-school choice. I haven't heard anybody on this panel, Democrat or Republican, who voiced anything other than support for the concept of school choice and letting parents choose, but, of course, all school choice is not created equal, and distinctions need to be made. And my Republican colleagues have oversimplified what school choice means, even to the point of parents signing away their rights.

There's certainly a difference between public school choice and the privatization of education, and we should not lose sight, as Ms. Fudge said, that over 90 percent of students in our country are served by public schools. Many of us support policies that increase choice for high quality public schools, policies like open enrollment, magnet schools, that Mr. Courtney mentioned, charter schools, and others. Ms. Carter eloquently shared her own personal story, of her process for finding the right school to meet her son's needs.

When it comes to education, a one-size-fits-all policy simply doesn't work, and choice is important. Ms. Carter did extensive research and exercised her choice after meeting with a number of schools, traditional public and charter, and decided what was best for her son.

That being said, Ms. Carter spoke about some of the challenges she faced choosing the right school, and that's the case for many parents. School systems aren't often transparent enough about options, transportation remains a barrier to making school choice meaningful, and that's why it's important that we lift up and support all of our public school options. It's also why many of us find some of the options that Republicans have put on the table for private school choice troubling.

In her confirmation hearing, Donald Trump's nominee for Secretary of Education, Betsy DeVos, refused to say that she wouldn't take money away from public schools to pay for private vouchers. That should concern any of us who care about public schools and the 90-plus percent of students that they serve.

Today's hearing also brought to light what Republican school choice means for students' Federal civil rights protections. Private schools are often not subject to requirements under Title VI, Title IX, IDEA, ADA, and ESSA. In fact, many parents are forced to sign away their rights under IDEA. I want to be clear on this. We had some clarifying questions, but the law is clear. Under U.S. Department of Education guidance, it clearly states that parentally-placed

private school children, and that's in contrast to private placement students under IDEA, have no individual entitlements to a fair and appropriate public education. Using the private vouchers, which is called parentally-placed private school child, does not have those rights, and, in fact, signs them away.

With your permission, Mr. Chairman, I'd like to submit some 2001 guidance, under President Bush's Secretary of Education, on this issue.

Chairman ROKITA. Without objection.

[The information follows:]



UNITED STATES DEPARTMENT OF EDUCATION

WASHINGTON, D.C. 20202-_____

MAR 30 2001

John W. Bowen,
 School Board Attorney
 Pinellas County School Board
 P.O. Box 2942
 Largo, Florida 33779-2942

Dear Mr. Bowen:

Thank you for your letter to the U.S. Department of Education's Office for Civil Rights (OCR) dated October 19, 2000, written on behalf of the Pinellas County School Board and 17 other school boards in Florida as well as certain organizations. Your letter primarily concerns the application of the requirements of Section 504 of the Rehabilitation Act of 1973 (Section 504) and the Individuals with Disabilities Education Act (IDEA) to students with disabilities participating in your State's program of Scholarships to Public or Private Schools of Choice for Students with Disabilities authorized by Florida statute 229.05371 (referred to here as Scholarship Program).

The clarification that follows reflects requirements of Section 504 and its implementing regulation at 34 C.F.R. Part 104, Title II of the Americans with Disabilities Act of 1990 (Title II of the ADA) and its implementing regulation at 28 C.F.R Part 35, and Part B of IDEA and its implementing regulation at 34 C.F.R. Part 300. Title II of the ADA, which prohibits disability discrimination, applies to public entities regardless of whether they receive Federal funds. The nondiscrimination requirements under Title II of the ADA are similar to those under Section 504. Please note that since the Department administers Federal law, and not State law, this Office can not interpret the specific provisions of Florida law discussed in your inquiry. We suggest that any questions that you may have about specific interpretations of provisions of Florida law be directed to appropriate offices in your State.

The specific inquiries and responses follow:

1. Is a Florida student with a disability as defined in IDEA who attends an eligible private school approved by the State under Florida's Opportunity Scholarship Program for students with disabilities entitled to special education and related services in conformance with an IEP and all of the rights of a child with a disability who is served by a public agency?

In 1990, the Department provided an explanation of the relevant requirements of Federal law applicable to children with disabilities enrolled by their parents in private schools pursuant to the Milwaukee choice program in response to an inquiry from then Governor Tommy G. Thompson (Thompson Letter). Because it appears to us that the characteristics of the Scholarship Program bear similarities to those of the Milwaukee choice program, we believe that the clarification provided regarding the Milwaukee choice program serves as guidance in this regard. A copy of that letter is enclosed for your information.

As we understand it, the Scholarship Program is not financed with Federal special education funds or any other Federal funds. As noted in the Thompson letter, "the private schools are not 'recipients' of Federal funds and their programs and activities are not federally-assisted."



Page 2 - Mr. John W. Bowen

Therefore, Federal civil rights laws, including Section 504, do not directly apply to the private schools participating in the Scholarship Program. Further, Title II of the ADA does not directly apply, as the private schools are not public entities.

However, because the Florida SEA receives Federal financial assistance, Section 504 and Title II of the ADA do apply to all of the SEA's operations, including the SEA's administration of the Scholarship Program. Under Section 504 and Title II of the ADA, the SEA must ensure that participating private schools do not exclude a Scholarship Program student with a disability "if the person can, with minor adjustments, be provided an appropriate education within the school's program." 34 C.F.R. § 104.39 (a).¹ However, the SEA would not be required to ensure that the participating private schools "provide an appropriate education to ... students [with disabilities] with special educational needs if [the participating private schools do] not offer programs designed to meet those needs." See 34 C.F.R. Part 104, App. A at 28.

With regard to IDEA, and consistent with the Thompson Letter, we also conclude that if the FDE and its local school districts have made FAPE available to eligible children with disabilities in a public school but their parents elect to place them in private schools through the Scholarship Program, then such children are considered "private school children with disabilities" enrolled by their parents. See 34 C.F.R. §300.450. Under IDEA, such parentally placed private school students with disabilities have no individual entitlement to a free appropriate public education including special education and related services in connection with those placements. In order to avoid parental misunderstanding, the Department strongly recommends that the State or local educational agency notify parents who choose private school placement under the Scholarship Program that the student may retain certain rights under Section 504 and Title II of the ADA, although the student will not be entitled to a free appropriate public education under IDEA, while enrolled in the private school.

It should be noted that IDEA provides for a process by which limited services may be provided to some parentally placed private school students with disabilities. 34 CFR §300.453-300.462. This means that those children with disabilities attending participating private schools through the Scholarship Program must be considered for any limited special education and related services that may be available to them, in light of the available funding and the total number of private school children with disabilities and their needs, in the same manner as other children with disabilities enrolled in participating or nonparticipating private schools. Under IDEA, if the parents decide to return or re-enroll their IDEA-eligible child into the public school system, that child would be entitled to FAPE.

2. Is it a violation of Section 504 to exclude up to 95% of students with disabilities from participating in the Opportunity Scholarship Program [for students with disabilities] and to fail to ensure that students with disabilities participating in the regular Opportunity Scholarship Program are provided a free appropriate public education?

No. We note that the Scholarship Program at issue above is one exclusively for students with disabilities. Therefore, prescribing percentages for the participation of students with disabilities

¹ This 504 regulations define an "appropriate education" as:
the provision of regular or special education and related aids and service that (i) are designed to meet individual educational needs of handicapped persons as adequately as the needs of nonhandicapped persons are met and (ii) are based upon adherence to procedures that satisfy the requirements of §§ 104.34, 104.35, and 104.36.

34 CFR 104.33.

Page 3 - Mr. John W. Bowen

in this Scholarship Program, with 5 per cent of disabled students participating in the first year and incremental increases in participation of students with disabilities in succeeding years is not a violation of Section 504. In further response to your second question and in light of our response to your first inquiry, we believe that Section 504, Title II of the ADA, and the IDEA do not apply directly to the private schools participating in the regular Opportunity Scholarship Program. However, as further discussed above, Section 504, Title II of the ADA, and the IDEA do apply to the SEA with respect to its administration of the regular Opportunity Scholarship Program.

We hope that you find this response to your questions helpful. This letter is not intended to address any other compliance issues under Section 504 or the other statutes that OCR enforces, including Title II of the Americans with Disabilities Act of 1990, Title VI of the Civil Rights Act of 1964, Title IX of the Education Amendments of 1972, or the Age Discrimination Act of 1975. Similarly, this letter is not intended to address any other compliance issues under Part B of IDEA. If you have any questions about this letter, please contact Lilian Dorka in OCR at 202-205-5469 or JoLeta Reynolds in the Office of Special Education Programs, at 202-205-5507.

Sincerely,

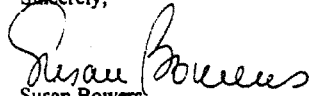

Susan Bowers
Acting Deputy Assistant Secretary
for Civil Rights

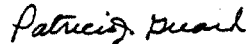

Patricia J. Guard
Acting Director
Office of Special Education Programs

cc: Shann Goff
Chief, Bureau of Instructional Support and Community Services
Florida Department of Education

Gary Walker
Director
OCR Atlanta Office



UNITED STATES DEPARTMENT OF EDUCATION
OFFICE OF SPECIAL EDUCATION AND REHABILITATIVE SERVICES

JUN 27 2003

[REDACTED]

This is in response to the inquiry set forth in your March 18, 2003 electronic letter and during subsequent telephone conversations between you and Wendy Tada and Dale King, members of the Office of Special Education Programs (OSEP). You asked for clarification regarding a proposed alternative special education program for your State, intended to be modeled after Florida's McKay scholarship program. As you stated in your electronic letter, you are proposing to offer parents of children in special education "an option, other than mediation, to allow their child to attend an alternative State approved special education program other than where their child is presently assigned." You specifically asked if federal funds provided under the Individuals with Disabilities Education Act (IDEA) could be used to pay tuition at a public or private State-approved special education program. Since you reference providing parents an additional placement option and the McKay scholarship program, it is our understanding that alternate State-approved private school placement options are intended to be selected by the parents rather than as a way for public agencies to provide a free appropriate public education (FAPE) through the regular IDEA placement process. Based upon this understanding, the availability of federal funds for such enrollment will primarily depend on whether the student's placement is into a public or private program. A discussion of the various issues is set out below.

Children Enrolled in Private Schools By Their Parents. Based upon our review of the draft legislation, your communications with staff and the stated intent to model the proposed program after the McKay Scholarship program in Florida, it is our understanding that Connecticut is **not** proposing to provide FAPE to students with disabilities through private school placements under this program. Under the IDEA, where the State and its local school districts have made FAPE available to eligible children with disabilities in its public school system but their parents elect to place them in private schools through a program such as the one you are proposing, such children would be considered "private school children with disabilities" enrolled by their parents. See 34 CFR. §300.450. Under IDEA, such parentally-placed private school children with disabilities have no individual entitlement to FAPE, including special education and related services. Under these circumstances, it would not be permissible to use IDEA funds to pay for the tuition of children enrolled by their parents in private alternative State-approved special education programs. Instead, a proportional share of IDEA funds would be used to provide limited services to parentally-placed private school students in

Page 2 - [REDACTED]

accordance with specific federal provisions covering such students. (As you are intending to model your program proposal on Florida's McKay Scholarship program, it is important to point out that the Florida program uses State funds, not federal funds, to finance its private school scholarships.)

IDEA requires local education agencies (LEAs) to consult with representatives of parentally-placed private school children with disabilities to consider the special education and related services that may be available in light of available funding, the number of private school children with disabilities, the needs of private school children with disabilities, and their location. 34 CFR §300.454(b). "Amounts expended for the provision of those services by a [LEA] shall be equal to a proportionate amount of the Federal funds available under [Part B]," based on the number of children with disabilities in private schools relative to the number of such children in public schools. 20 USC §1412(a)(10).

Public School Choice. Under the IDEA, LEAs must ensure that funds received under Part B of the IDEA are used only to pay the excess costs of providing special education and related services to children with disabilities and expended in accordance with the applicable provision of the Act. See 34 CFR §300.230. In designing a program that allows parents to choose between public school programs, Connecticut must ensure that FAPE is made available and should carefully review the Department's previous letters on this topic (enclosed, see below).

In general, the Department has previously approved public school choice programs 1) where parents choose which public agency will be responsible for providing FAPE; and 2) that allow IDEA placement teams to offer the parent a choice between two or more placement options capable of providing FAPE. However, the Department has rejected a public school choice program that was based solely on parental choice, without regard to the provision of FAPE.

In a 1990 joint OSERS-OCR letter, the Department stated that:

if a State chooses to allocate district responsibility for FAPE based upon parental choice, that is not inconsistent with [IDEA] providing that the effect of this will not result in the denial of any of the rights guaranteed by the [IDEA]. Consequently, it is not inconsistent with [IDEA] for choice legislation to require that responsibility for providing FAPE be delegated to the district of choice.

Letter to Tatel, 16 EHLR 349 (1990). Under such a program, parents may choose between one or more public agencies that, if chosen, would be responsible for making FAPE available consistent with the IDEA. Likewise, the Department also previously stated that:

it would be permissible under [the IDEA] for school officials to give the parent the right to select a child's placement from one or more public placements that

Page 3 - [REDACTED]

have been determined appropriate for a child by the placement team based upon applicable [IDEA] requirements.

Letter to Siegel, 16 EHLR 797 (1990). Under both such programs, the responsible public agency could use IDEA funds to pay the excess costs of providing FAPE.

However, it also is important to note that in 1991, the Department concluded that a State law "permitting a public agency to base a placement decision solely on 'parent option' or 'parent preference' is inconsistent with Federal requirements." Letter to Bayh, 17 EHLR 840; see also, Letter to Evans, 17 EHLR 836 (1991); Letter to Lugar, 17 EHLR 834 (1991); and Letter to Bina, 18 EHLR 582 (1991).

Mediation. Finally, I would like to address the issue of mediation that you raised in your electronic letter and in your phone conversations with Wendy Tada and Dale King. You stated that your proposed bill would offer parents of special education students "an option, other than mediation" to attend an alternative State-approved special education program. I want to be clear that under the IDEA, mediation must be offered whenever a due process hearing is requested. See 34 CFR §300.506. Therefore, it would not be permissible under IDEA to offer an alternative State-approved special education program in lieu of mediation. That is, parents of students with disabilities attending public school programs and eligible to receive FAPE must have the option of mediation whenever a due process hearing is requested, regardless of whether or not they are offered enrollment in an alternative State-approved special education program under the proposed State legislation.

We hope this information is helpful. This letter is not intended to address any compliance issues under Section 504 or other statutes, including the No Child Left Behind Act. Similarly, this letter is not intended to address any other compliance issues under Part B of IDEA. Please feel free to contact Wendy Tada at (202) 205-9094 or Dale King at (202) 260-1156 if you need further assistance.

Sincerely,



Stephanie S. Lee
Director
Office of Special Education Programs

cc: George P. Dowaliby
Bureau Chief
Connecticut Department of Education



UNITED STATES DEPARTMENT OF EDUCATION
OFFICE OF SPECIAL EDUCATION AND REHABILITATIVE SERVICES

JUL 1 2003

[REDACTED]

I am writing in response to a series of letters you have written to the Department. I hope the following information is helpful.

Your main question throughout these letters appears to be whether there is an entitlement under the Individuals with Disabilities Education Act (IDEA), 20 U.S.C. § 1400 et seq., which would allow parents to choose any private school that is part of a choice program, and have special education and related services provided at that school.

In your letters, you cite the provision in 34 C.F.R. § 300.552(c), which requires that each public agency ensure that "unless the IEP of a child with a disability requires some other arrangements, the child is educated in the school he or she would attend if nondisabled."

I first note that 34 C.F.R. § 300.552(c) was developed in the context of special education programs within local education agency (LEA) schools, and not choice programs. However, even with regard to LEA programs, the IDEA does not require that LEAs make all services needed by all students with disabilities available at all locations.

Moreover, the IDEA does not require that private schools provide special education and related services that meet the needs of all students with disabilities, and it does not require that States certify all private schools to provide services to all students. In Letter to Reedy, 16 IDELR 1364 (OSEP 1990), the Office of Special Education Programs responded to the question of whether private schools serving students in Vermont are "bound by the same admission and discipline policies that apply to public schools." OSEP explained that "if a private school or facility is unable or unwilling to provide an appropriate educational program for a child who is disabled, the public agency remains responsible for providing, or ensuring the provision of, a FAPE to that child, either by locating another appropriate private school placement for the child or by educating the child in a public agency program."

The United States Court of Appeals for the Second Circuit agreed with the policy in Letter to Reedy that private schools are not subject to the same admission policies that apply to public schools. St. Johnsbury Academy v. D.H. et. al., 240 F.3d 163 (2nd Cir. 2001). In St. Johnsbury Academy, a parent contested a private school's policy that

students had to perform at or above the fifth grade level before being assigned to the Academy's ninth grade mainstream academic classes. The Court held that, although the public school was responsible for making a free appropriate public education (FAPE) available to the student (which in Vermont was done by paying students' tuition at private schools or schools outside the district), that particular private school was not required to change its policy to ensure that the student was able to receive FAPE at that school.

I will also address your request that this Department review the State's response to the issues we forwarded to the State for review, pursuant to its State complaint procedures under 34 CFR §§ 300.660 – 300.662, in a letter dated February 26, 2003. Although the complaint procedures applicable to Part B of the Individuals with Disabilities Education Act (Part B), prior to May 11, 1999, included a provision that after a complaint had been filed with the State and the State had acted on it, either party to the complaint could request the U.S. Secretary of Education to review the State's final decision; on March 12, 1999, new final regulations were published that no longer include a Secretarial review process. The new regulations became effective May 11, 1999, so the Secretarial review process is no longer available. As with other issues raised under the IDEA, if you disagree with the response from the State, you may take advantage of the procedures for the filing of a due process hearing under the IDEA. If you wish the State to address additional issues, you may file a new complaint with the State.

In your April 22, 2003 letter to Ms. Jill Harris you also ask about services plans. Contrary to the statements in your letter, school systems are not required to prepare services plans for all children with disabilities placed in private schools by their parents. Instead, under 34 CFR § 300.455(b), services plans are prepared only for private school children with disabilities who are designated to receive services under 34 CFR § 300.452. If you wish to raise the issue of a services plan for a student who has been designated to receive services, you may file a complaint with the State.

Finally, in response to your question, the Office of Civil Rights (OCR) address where we sent the February 26, 2003 letter is:

U.S. Department of Education
Office for Civil Rights
330 C Street, S.W.
Washington, D.C. 20202

As you requested, we are forwarding a copy of your February 27, 2003 letter to OCR, along with a copy of this letter.

 - Page 3

I hope this information is helpful.

Sincerely,

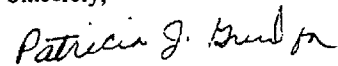

Stephanie S. Lee
Director
Office of Special Education Programs

cc: Vermont Department of Education
U.S. Department of Education, Office for Civil Rights



UNITED STATES DEPARTMENT OF EDUCATION
OFFICE OF SPECIAL EDUCATION AND REHABILITATIVE SERVICES

JUN 27 2005

Contact Person:

Name: JoLeta Reynolds
Telephone: 202-245-7468

OSEP 05-09

MEMORANDUM

TO: Chief State School Officers

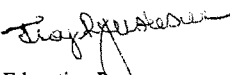
FROM: Troy R. Justesen 
Acting Director
Office of Special Education Programs

SUBJECT: Obligations of States and local educational agencies to parentally-placed private school children with disabilities

The obligation of States and local educational agencies (LEAs) to children with disabilities enrolled by their parents in private elementary schools and secondary schools will change beginning July 1, 2005, the effective date of these provisions in the Individuals with Disabilities Education Improvement Act of 2004 (IDEA 2004). The focus of this memorandum is to provide guidance to States and LEAs in complying with the following requirements in 20 U.S.C. 1412(a)(10) of IDEA 2004: (1) regarding the agency responsible for providing equitable special education and related services to parentally-placed private school children with disabilities, and (2) determining the proportionate amount of Federal funds to be expended by the LEA for such children attending private schools located in their district.

IDEA 2004 retains the provision in IDEA that each LEA spend a proportionate amount of the required subgrants it receives from the State educational agency (SEA) under 20 U.S.C. 1411 and 20 U.S.C. 1419 for special education and related services to children with disabilities enrolled by their parents in private elementary schools and secondary schools (20 U.S.C. 1412(a)(10)(A)(i)(I)). However, under IDEA 2004, to calculate the proportionate amount of Federal Part B funds, the LEA, after timely and meaningful consultation with representatives of private schools, must conduct a thorough and complete child find process to determine the number of parentally-placed children with disabilities attending private schools *located in the*

Page 2

LEA [emphasis added] (20 U.S.C. 1412(a)(10)(A)(i)(II)). In addition, the obligation to spend a proportionate amount to provide services to children with disabilities enrolled by their parents in private schools now refers to children enrolled by their parents in private elementary schools and secondary schools in the LEA. (20 U.S.C. 1412(a)(10)(A)(i)). These are significant changes from the current regulations in which the responsibility to conduct child find (34 CFR 300.451) and provide equitable services to parentally-placed private school children rests with *the LEA in which the children reside* [emphasis added] (34 CFR 300.453).

Therefore, beginning July 1, 2005, each LEA must conduct child find, determine the proportionate share of Part B funds, and provide equitable services to parentally-placed private school children with disabilities who attend private schools located in the LEA without regard to where the children reside. This change means that LEAs consult with representatives of the private schools located in the district, thereby eliminating the need for LEAs to contact private school representatives outside of their jurisdiction. The change also means that representatives of private schools have only one LEA to consult with to ensure that children with disabilities enrolled in their schools can participate in IDEA equitable services.

The Department recognizes that States and LEAs may not have accurate data at this time to calculate the proportionate amount of Federal funds consistent with the requirements of IDEA 2004. Therefore, the Secretary is exercising the transition authority under IDEA 2004, which allows the Secretary to take necessary steps for an orderly transition from the current regulatory requirements to the requirements under IDEA 2004 (20 U.S.C. 1400 note) as discussed in the following paragraph:

The Secretary will allow, for the 2005-06 school year only, States and LEAs to use the best available data to calculate the proportionate amount of their IDEA Part B funds that must be expended on services for parentally-placed private school children with disabilities attending private schools located in their jurisdiction, rather than requiring new child counts of parentally-placed private school children with disabilities by the district of the private school's location. The State must use the same method across all LEAs within the State.

Please note, that this flexibility does not affect the obligation of States and LEAs to meet the child find requirements in 20 U.S.C. 1412(a)(3) to identify, locate, and evaluate parentally-placed private school children with disabilities attending schools located in their area of jurisdiction (20 U.S.C. 1412(a)(10)(A)(ii)). Nor does the flexibility affect the obligation of LEAs to expend the proportionate share of funds for services, including direct services, to parentally-placed private school children with disabilities attending schools located in their area of jurisdiction.

The Department wants to stress that States are bound by all other provisions of IDEA 2004, and until the final regulations are issued, the existing regulations that are not inconsistent with IDEA 2004. For example, IDEA 2004 requires that LEAs, or where appropriate, an SEA, consult with representatives of private schools and representatives of parents of parentally-placed private school children with disabilities regarding:

Page 3

- (a) The child find process and how parentally-placed private school children suspected of having a disability can participate equitably, including how parents, teachers, and private school officials will be informed of the process;
- (b) The determination of the proportionate amount of Federal funds available to serve parentally-placed private school children with disabilities including the determination of how the amount was calculated;
- (c) The consultation process among the LEA, private school officials, and representatives of parents of parentally-placed private school children with disabilities, including how the process will operate throughout the school year to ensure that parentally-placed private school children with disabilities identified through the child find process can meaningfully participate in special education and related services;
- (d) How, where, and by whom special education and related services will be provided for parentally-placed private school children with disabilities, including a discussion of types of services, including direct services and alternate service delivery mechanisms; how such services will be apportioned if funds are insufficient to serve all children; and how and when those decisions will be made; and
- (e) How, if the LEA disagrees with the views of the private school officials on the provision of services or the types of services, the LEA will provide to the private school officials a written explanation of the reasons why the LEA chose not to provide services directly or through a contract. (20 U.S.C. 1412(a)(10)(A)(iii))

States and LEAs are expected to comply with these consultation requirements beginning July 1, 2005.

The Department anticipates posting a list of "Frequently Asked Questions" regarding the responsibilities of States and LEAs under IDEA 2004 to serve parentally-placed private school children with disabilities. Should you have any questions, please contact your State contact in the Office of Special Education Programs at 202-245-7459 or JoLeta Reynolds, Office of Policy and Planning, Office of Special Education and Rehabilitative Services, at 202-245-7468.

cc: State Directors of Special Education
 Congressional Staff
 Federal Resource Center
 Regional Resource Centers
 Parent Training Centers
 Protection and Advocacy Agencies
 Section 619 Coordinators
 Private School Associations



UNITED STATES DEPARTMENT OF EDUCATION
OFFICE OF SPECIAL EDUCATION AND REHABILITATIVE SERVICES

AUG 22 2007

Colette Chapman
Exceptional Student Services
Arizona Department of Education
1535 West Jefferson, Bin 24
Phoenix, Arizona 85007-3280

Dear Ms. Chapman:

This letter is written in response to Dr. Lynn Busenbark's electronic mail (email) communication to Debra Jennings, your State contact on my staff, dated March 2, 2007, in which she asked the following question: "Do children enrolled in for-profit private schools qualify for a proportionate share?"

Under 34 CFR §300.130, parentally-placed private school children with disabilities are defined as children with disabilities enrolled by their parents in private, including religious, schools or facilities that meet the definition of elementary school in 34 CFR §300.13 or secondary school in 34 CFR §300.36.

The definition of "elementary school" at 34 CFR §300.13 states: *Elementary school* means a nonprofit institutional day or residential school, including a public elementary charter school, that provides elementary education, as determined under State law. The definition of "secondary school" at 34 CFR §300.36 states: *Secondary school* means a nonprofit institutional day or residential school, including a public secondary charter school that provides secondary education, as determined under State law, except that it does not include any education beyond grade 12. (Emphasis added.)

Because both definitions require that the schools be nonprofit, children with disabilities placed by their parents in for-profit private schools are not included in the definition of "parentally-placed private school children with disabilities." Therefore, they would not be included in the proportionate share calculation or be eligible for equitable services under 34 CFR §§300.130-300.144.

The child find obligation exists independently from the requirement to expend a proportionate share of IDEA funds to provide services to eligible parentally-placed private school children with disabilities. Under section 612(a)(3)(A) of IDEA and 34 CFR §300.111, a State must ensure that all children with disabilities residing in the State, including children with disabilities attending private schools, and who are in need of special education and related services, are identified, located, and evaluated; this includes children with disabilities attending for-profit private schools. A State determines which public agency is responsible for conducting child find under 34 CFR §300.111 for children suspected of having a disability attending for-profit private schools. Generally, this agency is the LEA in which the child resides.

400 MARYLAND AVE., S.W., WASHINGTON, D.C. 20202
www.ed.gov

Our mission is to ensure equal access to education and to promote educational excellence throughout the Nation.

Page 2 – Colette Chapman

Under 34 CFR §300.300(a)(1), a public agency must obtain parental consent before conducting an initial evaluation to determine if the child is a child with a disability under IDEA. If parents place their child in a private school at their own expense and do not provide consent for an initial evaluation or reevaluation, or the parents fail to respond to a request to provide consent, the public agency may not override the parents' consent using the procedural safeguards provided in IDEA. (See 34 CFR §300.300(d)(4))

Based on section 607(e) of IDEA, we are informing you that our response is provided as informal guidance and is not legally binding, but represents an interpretation by the U.S. Department of Education of IDEA in the context of the specific facts presented.

I hope this information is helpful to you. If you have further questions, please do not hesitate to contact Debra Jennings at 202-245-7389.

Sincerely,



Patricia J. Guard
Acting Director
Office of Special Education
Programs



UNITED STATES DEPARTMENT OF EDUCATION
 OFFICE OF SPECIAL EDUCATION AND REHABILITATIVE SERVICES
 AUG 29 2007

Dr. Michael Mendelson
 Director of Special Education
 Scarsdale Public Schools
 2 Brewster Road
 Scarsdale, New York 10583

Dear Dr. Mendelson:

This letter is in response to your correspondence dated May 21, 2007, to the Office of Special Education and Rehabilitative Services. This response is based on information from your letter requesting guidance on a local educational agency's (LEA's) responsibility for meeting the provisions contained in 34 CFR §§300.130-300.144 of the final regulations for Part B of the Individuals with Disabilities Education Act (Part B) regarding parentally-placed private school children with disabilities when a parent enrolls their child in a special education private school.

In particular, you explained in your letter that a parent of a child who resides in your school district, who was denied tuition reimbursement for the cost of her child's placement at an out-of-State private residential facility dedicated to the education of children with learning disabilities, is electing to continue her child's enrollment at that facility for the upcoming school year and requested a services plan for her child from the LEA where that private school is located. You stated that the parent was informed by the LEA where the private school is located that it would not develop a services plan for her child because the LEA believes that the rights for parentally-placed private school children with disabilities are not applicable to children enrolled by their parents in nonpublic special education residential or day schools.

The 2004 Amendments to the IDEA significantly changed the manner in which States and LEAs must meet their obligations to the group of children enrolled by their parents in private elementary schools and secondary schools. Section 612(a)(10)(A) of the IDEA, codified at 20 U.S.C. 1412(a)(10)(A). Under the final Part B regulations implementing this statutory provision at 34 CFR §§300.130 through 300.144, responsibility for providing equitable services to parentally-placed private school children with disabilities has shifted from the LEA where the children's parents reside to the LEA where the private elementary schools or secondary schools or facilities the children attend are located. Thus, the LEA where the private schools the children attend are located must initiate child find activities, complete initial evaluations, consult with private school representatives, determine a proportionate share of its total Part B subgrant to be expended on services for this population, and offer equitable services to parentally-placed private school children with disabilities. 34 CFR §§300.131 through 300.134. These provisions are applicable even if parentally-placed private school children do not reside in the State where the private school they attend is located. 34 CFR §300.131(f)

400 MARYLAND AVE., S.W., WASHINGTON, DC 20202-2500
 www.ed.gov

Our mission is to ensure equal access to education and to promote educational excellence throughout the nation.

(clarifying the obligation of the LEA where the private schools the children attend are located to conduct child find for children residing out-of-State).

The term parentally-placed private school children with disabilities “is defined as children with disabilities enrolled by their parents in private, including religious, schools or facilities that meet the definition of elementary school in §300.13 or secondary school in §300.36, other than children with disabilities covered under §§300.145 through 300.147.” 34 CFR §300.130. Note that this definition incorporates IDEA’s definition of elementary school and secondary school. Under 34 CFR §300.13, “elementary school means a nonprofit institutional day or residential school, including a public elementary charter school, that provides elementary education, as determined under State law.” Under 34 CFR §300.36, “secondary school means a nonprofit institutional day or residential school, including a public secondary charter school that provides secondary education, as determined under State law, except that it does not include any education beyond grade 12.” Neither definition specifically excludes schools that provide special education and related services. Therefore, if the special education private school where the child prompting your inquiry otherwise meets the applicable definition of “elementary school” or “secondary school,” the LEA where that private school is located must consider children with disabilities enrolled by their parents in that school as “parentally-placed private school children” as defined in Part B who are subject to the provisions in 34 CFR §§300.130 through 300.144. However, even though the children may meet the definition of “parentally-placed private school children with disabilities” under IDEA, this does not necessarily mean that the child prompting your inquiry will receive special education and related services from the LEA where the private school the child is attending is located or that the responsible LEA must develop a services plan for the child at the parent’s request.

Under IDEA, a parentally-placed child with a disability does not have an individual right to receive some or all of the special education and related services that the child would receive if enrolled in a public school program. 34 CFR §300.137(a). Further, only those parentally-placed private school children with disabilities whom the LEA elects to serve will receive a services plan. 34 CFR §300.138(a)(2). Before any decisions are made about how the LEA will meet the needs of the parentally-placed private school children with disabilities attending private schools located in the LEA’s jurisdiction, a timely and meaningful consultation must occur between the LEA and private school representatives and representatives of parents of parentally-placed private school children with disabilities. 34 CFR §§300.134 and 300.137(b).

Topics addressed during consultation include how child find will be conducted to ensure the equitable participation of parentally-placed private school children with disabilities, how the proportionate share of Federal funds available for services for these children is determined, how the consultation process itself will be conducted to ensure that children identified through child find can meaningfully participate, and how, where and by whom special education and related services will be provided, including the types of services to be provided. 34 CFR §300.134(a) through (d). Thus, although the LEA where the private school the child attends is located could not refuse to consider the needs of

Page 3 – Dr. Michael Mendelson

children with disabilities who are parentally-placed at special education day or residential private schools by virtue of their attendance in such schools if those schools otherwise meet the applicable definitions of “elementary school” and “secondary school,” the responsible LEA, could, after timely and meaningful consultation, elect not to serve children with disabilities who are enrolled by their parents in such private schools.

Based on section 607(c) of the IDEA, we are informing you that our response is provided as informal guidance and is not legally binding, but represents an interpretation by the U.S. Department of Education of the IDEA in the context of the specific facts presented.

We hope that you find the responses to your questions helpful. If you need further assistance, please feel free to contact my office.

Sincerely,



Patricia J. Guard
Acting Director
Office of Special Education
Programs

Mr. POLIS. And just to quote in part this memo from March 30, 2001, it's still enforced, "under IDEA, "such parentally-placed private school students with disabilities have no individual entitlement to a free appropriate public education, including special education-related services in connection with those placements."

So, again, it's not about who the provider is. There are many private providers that through private school placement under IDEA, the parents maintain those full rights. And I would add those aren't always private schools; they're often private services that are contracted by the school district. They can be, in extreme cases, an entire school, even a boarding school in another State. And I've heard of that in some cases, if that's the only appropriate education, but the parents maintain those rights. And under this advisory and the law, they lose those rights when they become parentally placed. And so that's very important to emphasize.

Private schools can also deny admission to students with special needs and students who identify as LGBT. And for many of those reasons, we should be concerned about Federal taxpayer dollars supporting institutions that are allowed to discriminate.

I'm a strong supporter of school choice, but not the school privatization proposed by my Republican colleagues. Independent schools are independent for a reason. They want to remain independent, and that's perfectly appropriate and a fine decision that they make. If they want to play by the same rules as public schools and accept students without discrimination and without parents signing away their IDEA rights, there's common ground to find a way to work together. And many school districts do contract with private providers in their district under those terms and conditions.

My first and foremost priority is supporting the education of students across our country, and we want to make sure that we encourage rather than discourage transparency and accountability, as well as promote civil rights for all schools that are publicly funded.

I yield back the balance of my time.

Chairman ROKITA. I thank the gentleman.

In closing, I'd like to respond to the gentleman by submitting some -- also submitting some records -- or excuse, some documents for the record, some of -- at least one of which, I noticed, is the same one he referenced. So I'd ask unanimous consent to enter into the record a study from the National Alliance for Public Charter Schools on the estimated enrollment in charter public schools for the 2016-2017 school year, and letters from the Department of Education from 1990, 2001, and from the Obama administration in 2012, each of them confirming that parents who choose for their child to attend a private school, including as part of a public scholarship program, are making a choice, in fact, making a choice that school is the right fit for their child, as allowed under IDEA and any of our other civil rights laws.

[The information follows:]

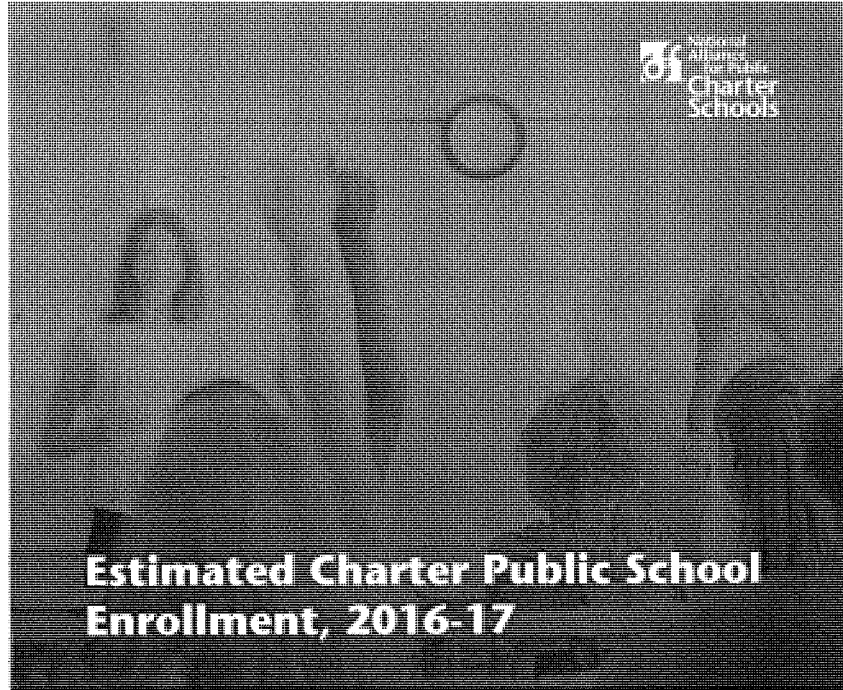

Charter School Enrollment Growth

Across the country, more than 300 new charter public schools opened in the fall of 2016. Charter schools are public schools that have flexibility to meet students' unique needs, while being held accountable for advancing student achievement. Every year, the National Alliance for Public Charter Schools (National Alliance) collects data on the number of charter schools that opened and closed in each state that has operating charter schools. This information is used to determine the current number of charter schools in each state, as well as to estimate total charter school enrollment at the state and national levels.

In 2016-17, there are more than 6,900 charter schools, enrolling an estimated 3.1 million students. Over the past 10 years, enrollment in charter schools has nearly tripled—from 1.2 million students in 2006-07 to an estimated 3.1 million in 2016-17. Between 2015-16 and 2016-17, estimated charter school enrollment increased by over 200,000 students. The estimated 7 percent growth in charter school enrollment between fall 2015 and fall 2016 demonstrates continued parental demand for high-quality educational options.

Estimated Charter Public School Enrollment, 2016-17

National Enrollment in Charter Public Schools, 2006-07 to 2016-17

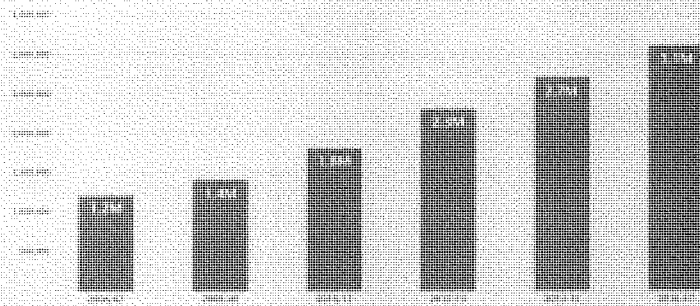

Source: Data for 2006-07 to 2009-10 from the U.S. Department of Education, National Center for Educational Statistics, IPEDS Data Center, Public Charter Schools Survey. Data for 2010-11 are obtained from the Public Charter Schools Institute. Data for 2011-12 to 2016-17 are obtained from the Public Charter Schools Institute.

The Number of Charter Public Schools Continues to Grow

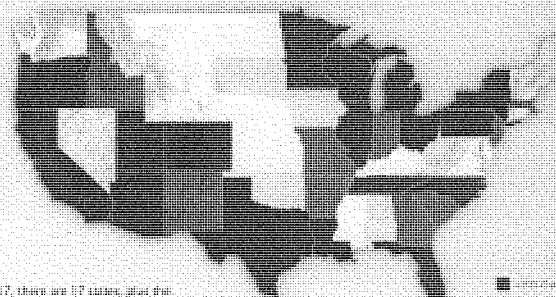

In 2016-17, there are 17 states and the District of Columbia that have at least 100 charter schools and 9 states have between 50 and 99 charter schools.

■ 100+ Charter schools
 ■ 50-99 Charter schools

Estimated Charter Public School Enrollment, 2016-17

Unmet Charter School Demand

When families have public school options, they increasingly select charter schools over district-run schools. In fact, a recent national survey of 1,000 parents with school-age children, commissioned by the National Alliance, found that 73 percent favor increasing the number of charter schools so that more students could enroll in them. Further, 78 percent of parents who have charter schools in their community, and 73 percent of parents who do not, favor having one open in their neighborhood. This suggests that, while the charter school sector continues to grow, it would likely grow faster if more charter schools were able to open.

In addition, 10 percent of parents indicated that a charter school would be their first choice—meaning that there are at least 2 million additional students whose parents would enroll them in a charter school today if they could.

Would You Favor or Oppose a Charter School Opening in your Community or Neighborhood?

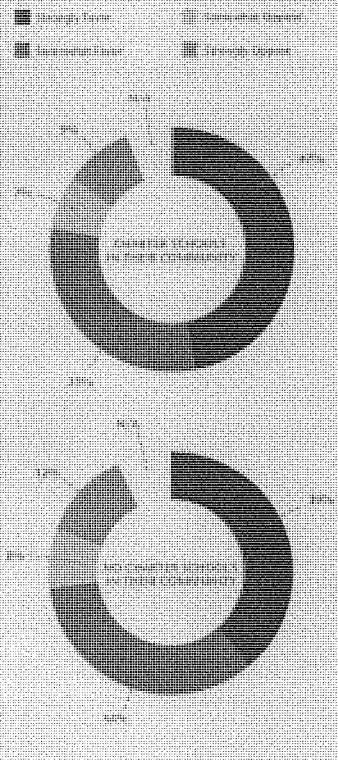

Estimated Charter Public School Enrollment, 2016-17

Estimated Number of Charter Public Schools & Students, 2016-17

While the charter school movement saw many new schools open this year, there were also 211 charter schools that ceased operation. These schools closed for a variety of reasons, including low enrollment, financial concerns, and/or low academic performance. The charter model gives charter schools the freedom to be more innovative, while being held accountable for improving student achievement. School closures provide evidence that the accountability part of the charter model is being upheld.

The following states experienced the largest number of charter school closures:

- California: 30 schools closed
- Texas: 30 schools closed
- Florida: 25 schools closed
- Ohio: 22 schools closed
- Georgia: 17 schools closed

The National Alliance for Public Charter Schools promotes meeting the demand for high-quality school options and encouraging well-planned school openings. We also support authorizers setting and enforcing high performance standards. The continued annual growth in both charter schools and charter students is positive evidence of a strong and growing movement as more than 300 new charter schools opened across the country.

The following states experienced the largest number of charter school openings:

- Texas: 64 schools opened
- California: 56 schools opened
- Florida: 26 schools opened
- Arizona: 18 schools opened
- New York: 16 schools opened

State	New Charters, Fall 2016	Closed Charters, Spring 2016	Net Gain Charters, 2016-17	Total Charter Schools, 2016-17	Charter School Growth %	Estimated Enrollment 2016-17	Charter School Student Growth %
AK	1	0	1	22	4%	6,600	4%
AR	9	2	7	73	11%	29,400	20%
AZ	18	11	7	547	1%	180,000	3%
CA	56	30	26	1,253	2%	604,700	6%
CO	13	1	12	238	5%	114,700	5%
CT	0	0	0	24	0%	9,700	6%
DC*	8	1	7	119	6%	42,400	9%
DE	0	2	-2	25	-7%	15,300	8%
FL	26	25	1	656	0%	291,200	8%
GA	8	17	-9	83	-10%	84,400	12%
HI	0	0	0	34	0%	10,900	5%
IA	0	0	0	3	0%	400	7%
ID	3	0	3	52	6%	21,400	5%
IL*	3	5	-2	143	-1%	65,500	2%
IN	9	3	6	95	7%	43,900	7%
KS	0	0	0	10	0%	3,800	16%
LA	8	1	7	146	5%	84,400	13%
MA	1	0	1	81	1%	44,200	10%
MD	1	4	-3	49	-6%	23,500	4%
ME	2	0	2	9	29%	2,000	32%
MI	2	8	-11	301	0%	146,100	0%
MN	7	5	2	167	1%	53,400	5%
MO	4	2	2	61	3%	23,000	6%
MS	1	0	1	3	50%	400	65%
NC	11	2	9	168	6%	91,800	11%
NH	0	0	0	26	0%	3,300	10%
NJ	4	5	-1	88	-1%	48,900	19%
NM	3	3	0	99	0%	25,400	6%
NV	2	0	2	39	5%	39,900	15%
NY	16	5	11	267	4%	132,100	14%
OH	8	22	-14	362	4%	121,000	1%
OK	3	0	3	37	9%	22,300	12%
OR	0	0	0	126	0%	32,900	7%
PA	9	2	7	183	4%	138,400	4%
RI	1	0	1	30	3%	8,000	9%
SC	0	1	-1	66	-1%	31,700	9%
TN	10	4	4	107	4%	30,000	1%
TX*	64	30	34	761	5%	315,200	13%
UT	3	5	-2	125	0%	71,500	5%
VA	1	0	1	9	13%	1,500	33%
WA	0	1	-1	7	-13%	1,300	10%
WI	7	12	-5	234	-2%	44,900	1%
WY	0	0	0	4	0%	500	2%
Total	329	211	118	6,939	2%	3,061,900	7%

* Data for DC, Illinois, and Texas represent campuses, rather than charters. In those states (and DC), a single charter can be held by multiple campuses.

Estimated Charter Public School Enrollment, 2016-17

Methodology

Data for this report were collected by contacting state departments of education and charter support organizations in each state to determine how many new schools opened in fall 2016 and how many schools closed during or after the last school year (2015-16).

Enrollment estimates were determined by using two-year average charter school growth rates for schools that have been open for more than three years and using statewide two-year average charter school growth rates for schools that have been open for three years or less. For schools that have been open for three years or less, the average statewide growth rate was multiplied by 1.5 to reflect the typically higher rate of growth for newer schools as they add additional grades and students. Schools that opened in fall 2016 were assumed to be the same size as the average new charter school that opened in the previous two years in that state.

Enrollment data for North Carolina were based on preliminary numbers from the state department of education. The data for Colorado, Georgia, and Utah were based on official enrollment counts from their respective state departments of education. Enrollment data for Arizona, California, Connecticut, Illinois, Maine, Missouri, New Jersey, New York, and Tennessee were provided by the state charter support organizations – rather than estimated.



UNITED STATES DEPARTMENT OF EDUCATION
OFFICE OF SPECIAL EDUCATION AND REHABILITATIVE SERVICES

NOV -7 2012

Michael L. Boswell, Esq.
Advocate's Legal Clinic
813 Deltona Boulevard, Suite A
Deltona, Florida 32725

Dear Mr. Boswell:

This is in response to your January 5, 2012 letter to Dr. Alexa Posny, former Assistant Secretary for the Office of Special Education and Rehabilitative Services, in which you posed questions related to the Office of Special Education Programs' (OSEP's) letter to Pinellas County School Board Attorney, John W. Bowen, dated March 30, 2001 (Bowen Letter). The Bowen letter contained the Department's interpretation of the applicability of Part B of the Individuals with Disabilities Education Act (IDEA), Section 504 of the Rehabilitation Act of 1973 (Section 504), and Title II of the Americans with Disabilities Act (Title II) to students with disabilities participating in Florida's Opportunity Scholarship Program, referred to in your letter, and here, as the McKay Scholarship Program.

OSEP administers Part B of the IDEA. We have reviewed your inquiry and concluded that the Department's interpretation of the IDEA, as set out in the Bowen letter, continues to reflect the Department's position regarding the obligations of the Florida Department of Education to students with disabilities enrolled in participating private schools through the McKay Scholarship Program. Because you also seek clarification regarding applicable due process rights under the IDEA, we are enclosing previous guidance that the Department has issued regarding the IDEA's requirements related to parentally-placed private school students with disabilities. The enclosed document, *Questions and Answers on Serving Children with Disabilities Placed by Their Parents at Private Schools*, (April 2011), addresses due process rights in section L and also can be found at <http://idea.ed.gov/explore/view/p/%2Croot%2Cdynamic%2COaCorner%2C1%2C>.

Your inquiry also raises questions about the requirements of Section 504 and Title II. The Department's Office for Civil Rights (OCR) enforces Section 504, which prohibits discrimination on the basis of disability by recipients of Federal financial assistance. OCR also shares enforcement responsibility with the U.S. Department of Justice for Title II, which prohibits discrimination on the basis of disability in State and local government services, programs, and activities, regardless of whether they receive Federal financial assistance. OSEP has referred the portions of your inquiry that seek clarification of the requirements of Section 504 and Title II to OCR for a direct response.

400 MARYLAND AVE. S.W., WASHINGTON, DC 20202-2600

www.ed.gov

The Department of Education's mission is to promote student achievement and preparation for global competitiveness by fostering educational excellence and ensuring equal access.

Page 2 - Michael L. Boswell, Esq

Based on section 607(e) of the IDEA, we are informing you that our response is provided as informal guidance and is not legally binding, but represents an interpretation by the U.S. Department of Education of the IDEA in the context of the specific facts presented.

If you have additional questions, please do not hesitate to contact Dr. Ken Kienas, at 202-245-7621 or by email at Ken.Kienas@ed.gov.

Sincerely,

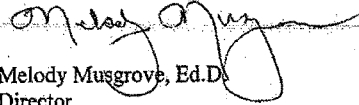

Melody Musgrove, Ed.D.
Director
Office of Special Education Programs

Attachment

cc: State Director of Special Education



UNITED STATES DEPARTMENT OF EDUCATION

WASHINGTON, D.C. 20202-_____

MAR 30 2001

John W. Bowen,
 School Board Attorney
 Pinellas County School Board
 P.O. Box 2942
 Largo, Florida 33779-2942

Dear Mr. Bowen:

Thank you for your letter to the U.S. Department of Education's Office for Civil Rights (OCR) dated October 19, 2000, written on behalf of the Pinellas County School Board and 17 other school boards in Florida as well as certain organizations. Your letter primarily concerns the application of the requirements of Section 504 of the Rehabilitation Act of 1973 (Section 504) and the Individuals with Disabilities Education Act (IDEA) to students with disabilities participating in your State's program of Scholarships to Public or Private Schools of Choice for Students with Disabilities authorized by Florida statute 229.05371 (referred to here as Scholarship Program).

The clarification that follows reflects requirements of Section 504 and its implementing regulation at 34 C.F.R. Part 104, Title II of the Americans with Disabilities Act of 1990 (Title II of the ADA) and its implementing regulation at 28 C.F.R. Part 35, and Part B of IDEA and its implementing regulation at 34 C.F.R. Part 300. Title II of the ADA, which prohibits disability discrimination, applies to public entities regardless of whether they receive Federal funds. The nondiscrimination requirements under Title II of the ADA are similar to those under Section 504. Please note that since the Department administers Federal law, and not State law, this Office can not interpret the specific provisions of Florida law discussed in your inquiry. We suggest that any questions that you may have about specific interpretations of provisions of Florida law be directed to appropriate offices in your State.

The specific inquiries and responses follow:

1. Is a Florida student with a disability as defined in IDEA who attends an eligible private school approved by the State under Florida's Opportunity Scholarship Program for students with disabilities entitled to special education and related services in conformance with an IEP and all of the rights of a child with a disability who is served by a public agency?

In 1990, the Department provided an explanation of the relevant requirements of Federal law applicable to children with disabilities enrolled by their parents in private schools pursuant to the Milwaukee choice program in response to an inquiry from then Governor Tommy G. Thompson (Thompson Letter). Because it appears to us that the characteristics of the Scholarship Program bear similarities to those of the Milwaukee choice program, we believe that the clarification provided regarding the Milwaukee choice program serves as guidance in this regard. A copy of that letter is enclosed for your information.

As we understand it, the Scholarship Program is not financed with Federal special education funds or any other Federal funds. As noted in the Thompson letter, "the private schools are not 'recipients' of Federal funds and their programs and activities are not federally-assisted."



Page 2 - Mr. John W. Bowen

Therefore, Federal civil rights laws, including Section 504, do not directly apply to the private schools participating in the Scholarship Program. Further, Title II of the ADA does not directly apply, as the private schools are not public entities.

However, because the Florida SEA receives Federal financial assistance, Section 504 and Title II of the ADA do apply to all of the SEA's operations, including the SEA's administration of the Scholarship Program. Under Section 504 and Title II of the ADA, the SEA must ensure that participating private schools do not exclude a Scholarship Program student with a disability "if the person can, with minor adjustments, be provided an appropriate education within the school's program." 34 C.F.R. § 104.39 (a).¹ However, the SEA would not be required to ensure that the participating private schools "provide an appropriate education to ... students [with disabilities] with special educational needs if [the participating private schools do] not offer programs designed to meet those needs." See 34 C.F.R. Part 104, App. A at 28.

With regard to IDEA, and consistent with the Thompson Letter, we also conclude that if the FDE and its local school districts have made FAPE available to eligible children with disabilities in a public school but their parents elect to place them in private schools through the Scholarship Program, then such children are considered "private school children with disabilities" enrolled by their parents. See 34 C.F.R. §300.450. Under IDEA, such parentally placed private school students with disabilities have no individual entitlement to a free appropriate public education including special education and related services in connection with those placements. In order to avoid parental misunderstanding, the Department strongly recommends that the State or local educational agency notify parents who choose private school placement under the Scholarship Program that the student may retain certain rights under Section 504 and Title II of the ADA, although the student will not be entitled to a free appropriate public education under IDEA, while enrolled in the private school.

It should be noted that IDEA provides for a process by which limited services may be provided to some parentally placed private school students with disabilities. 34 CFR §300.453-300.462. This means that those children with disabilities attending participating private schools through the Scholarship Program must be considered for any limited special education and related services that may be available to them, in light of the available funding and the total number of private school children with disabilities and their needs, in the same manner as other children with disabilities enrolled in participating or nonparticipating private schools. Under IDEA, if the parents decide to return or re-enroll their IDEA-eligible child into the public school system, that child would be entitled to FAPE.

2. Is it a violation of Section 504 to exclude up to 95% of students with disabilities from participating in the Opportunity Scholarship Program [for students with disabilities] and to fail to ensure that students with disabilities participating in the regular Opportunity Scholarship Program are provided a free appropriate public education?

No. We note that the Scholarship Program at issue above is one exclusively for students with disabilities. Therefore, prescribing percentages for the participation of students with disabilities

¹ This 504 regulations define an "appropriate education" as:
the provision of regular or special education and related aids and service that (i) are designed to meet individual educational needs of handicapped persons as adequately as the needs of nonhandicapped persons are met and (ii) are based upon adherence to procedures that satisfy the requirements of §§ 104.34, 104.35, and 104.36.

34 CFR 104.33.

Page 3 - Mr. John W. Bowen

in this Scholarship Program, with 5 per cent of disabled students participating in the first year and incremental increases in participation of students with disabilities in succeeding years is **not** a violation of Section 504. In further response to your second question and in light of our response to your first inquiry, we believe that Section 504, Title II of the ADA, and the IDEA do not apply directly to the private schools participating in the regular Opportunity Scholarship Program. However, as further discussed above, Section 504, Title II of the ADA, and the IDEA do apply to the SEA with respect to its administration of the regular Opportunity Scholarship Program.

We hope that you find this response to your questions helpful. This letter is not intended to address any other compliance issues under Section 504 or the other statutes that OCR enforces, including Title II of the Americans with Disabilities Act of 1990, Title VI of the Civil Rights Act of 1964, Title IX of the Education Amendments of 1972, or the Age Discrimination Act of 1975. Similarly, this letter is not intended to address any other compliance issues under Part B of IDEA. If you have any questions about this letter, please contact Lilian Dorka in OCR at 202-205-5469 or JoLeta Reynolds in the Office of Special Education Programs, at 202-205-5507.

Sincerely,



Susan Bowers
Acting Deputy Assistant Secretary
for Civil Rights

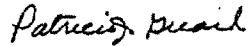

Patricia J. Guard
Acting Director
Office of Special Education Programs

cc: Sharn Goff
Chief, Bureau of Instructional Support and Community Services
Florida Department of Education

Gary Walker
Director
OCR Atlanta Office



UNITED STATES DEPARTMENT OF EDUCATION

WASHINGTON, D.C. 20202

SEP 21 1990

The Honorable Tommy G. Thompson
 Governor, State of Wisconsin
 Room 115 East
 State Capitol
 P.O. Box 7863
 Madison, Wisconsin 53707

Dear Governor Thompson,

This letter is in response to your letter of August 30, 1990, to Secretary Cavazos. You have asked for a Department opinion on the applicability of Part B of the Education of the Handicapped Act, 20 U.S.C. 1401 et seq. (EHA-B), and Section 504 of the Rehabilitation Act of 1973, 29 U.S.C. 794 (Section 504), to the Milwaukee Parental Choice Program (Choice Program).

We have reviewed Wisconsin Statute, Section 228.119.23, "Milwaukee Parental Choice Program," to determine whether and to what extent the EHA-B and Section 504 apply. In brief, the Choice Program provides that up to 1000 low-income pupils, grades K-12, who reside in Milwaukee may attend, at no charge, participating nonsectarian private schools. The pupils, or their parents, who wish to participate in this program apply directly to the private school of their choice; participating private schools must accept Choice Program students on a random basis. The State Department of Education (SEA) pays to the private school the funds it would have provided to Milwaukee, approximately \$2500 per pupil. Our understanding is that all funds paid to the schools are State, rather than Federal, funds.

The Department has determined that the EHA-B public placement requirements do not apply to placements in private schools resulting from parents' decisions to participate in the Choice Program, as long as a free appropriate public education (FAPE) is available to each handicapped child in the public school. Because it is the parent's decision to participate in the Choice Program, handicapped children in this program are "private school handicapped children" under the EHA-B and as such are not entitled to a FAPE. See 34 C.F.R. 300.450. These children are still eligible for any "equitable services" that may

The Honorable Tommy G. Thompson - page 2

be available to them, in the same manner as other handicapped children enrolled in participating or nonparticipating private schools. See 34 C.F.R. 300.403 and 76.650-.662. In addition, it should be noted that the Milwaukee public schools must always be able to make FAPE available for all children with handicaps in its jurisdiction, if the parents decide to opt out of the Choice Program.

Section 504 does not directly apply to the private schools, assuming that the State is using State and not Federal money to fund the placements. In the language of the regulations, the private schools are not "recipients" of Federal funds and their programs and activities are not federally-assisted based on their participation in the Choice Program. This means that the schools are not required, among other things, to file assurances directly with the Department; nor would their employment practices be covered, solely because of their participation in the Choice Program. See 34 C.F.R. Part 104, Subpart B. However, because the SEA receives Federal financial assistance, pursuant to the Civil Rights Restoration Act of 1987, Section 504 covers all of the SEA's operations, including the administration of the Choice Program. The SEA must ensure that participating private schools satisfy Section 504 with respect to handicapped children who wish to participate in the Choice Program. The standard that the SEA must apply to the private schools that participate in the Choice Program is that they cannot exclude a handicapped student "if the person can, with minor adjustments, be provided an appropriate education within the school's program." 34 C.F.R. 104.39(a).1/ In other words, under Section 504 the private schools are "not required to provide an appropriate education to handicapped students with special educational needs" where the schools do not offer programs designed to meet their needs. See 34 C.F.R. Part 104, App. A at 28.

In conclusion, although the EHA-B FAPE provisions do not apply to the children participating in this program, under Section 504, a handicapped student cannot be excluded from any

1/ The Section 504 regulations define an "appropriate education" as:

the provision of regular or special education and related aids and services that (i) are designed to meet individual educational needs of handicapped persons as adequately as the needs of nonhandicapped persons are met and (ii) are based upon adherence to procedures that satisfy the requirements of §§ 104.34, 104.35, and 104.36.

34 C.F.R. 104.33(b)(1). Sections 34 C.F.R. 104.34 -.36 address evaluation, placement with nonhandicapped children to the maximum extent appropriate, and procedural safeguards.

The Honorable Tommy G. Thompson - page 3

school participating in the Choice Program if that student can, with minor adjustments, be provided an appropriate education within the school's program. In addition, under EHA-B, participating handicapped children are still eligible for any "equitable services" that may be available to them, in the same manner as other handicapped children enrolled in participating or nonparticipating private schools.

We hope that you find this information helpful. If you have any questions, please do not hesitate to contact us.

Sincerely,

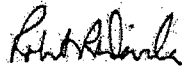

Robert R. Davila
Assistant Secretary
Office of Special Education
and Rehabilitative Services



Michael Williams
Assistant Secretary
Office for Civil Rights

MEMORANDUM

UNITED STATES DEPARTMENT OF EDUCATION

WASHINGTON, DC 20202

TO : Ted Sanders
Under Secretary

FROM : Richard D. Komer *Richard D. Komer*
Deputy Assistant Secretary
for Policy
Office for Civil Rights

SUBJECT: The Milwaukee Choice Program

JUL 27 1990

I. Introduction

On June 20, 1990, you charged me with preparing for you a memorandum specifically addressing whether, and to what extent, Section 504 of the Rehabilitation Act and the Education of the Handicapped Act apply to the Milwaukee Choice Program. These constitute exceedingly difficult issues of first impression for the Department, whose resolution is further complicated by the interaction of the Civil Rights Restoration Act of 1987, which amended Section 504 and which, in conjunction with its legislative history, presents a model of ambiguity. Nevertheless, I have reached the conclusions that follow.

Due to time constraints the various concerned POC's have not been given an opportunity to comment formally on this memorandum. I have met twice with the staff people from the various POC's that your memorandum of June 20 designated to assist me, and found their input to have been very helpful. I also gave them a very abbreviated opportunity to review this memorandum and have made some modifications in response to their comments. I take sole responsibility for its contents. The Office of General Counsel has, however, expressed agreement with the conclusions reached about both Section 504 and the EHA, and OSERS has also indicated agreement with the conclusion reached on the EHA.

II. Summary of Conclusions:

1. The Education of the Handicapped Act does not apply to placements in private schools resulting from parents' decisions to participate in the Milwaukee Choice Program. Any handicapped children so placed would be "private school handicapped children" under the EHA regulations (34 C.F.R. 300.450) and as such would not be entitled to the EHA's free, appropriate public education (FAPE) requirements. The relevant SEA and LEA would be required to ensure that "equitable services" are provided to these children, as they must with respect to other parentally placed children.

Page 2 - The Under Secretary

- 2a. Section 504 does not directly apply to the private schools, assuming as appears to be the case that the State is using State and not Federal money to fund the placements. In the language of the regulations, the private schools are not "recipients" of Federal funds and their programs and activities are not federally-assisted. This means the schools are not required, among other things, to file assurances directly with the Department; nor would their employment practices be covered (34 C.F.R. Subpart B).
- b. Section 504 does cover the State's activity of creating and administering the Choice Program, as part of the program or activity of a recipient of Federal financial assistance. The Civil Rights Restoration Act defines program or activity very broadly, as including "all the operations" of a state agency "any part of which is extended federal funds." The State's role in the Choice Program appears to be such an operation, even though the Federal funding is received for other parts or operations.
- c. The obligations imposed by Section 504 and the implementing regulations on the State Agency are far less clear. The statute provides virtually no guidance, and while several provisions of the regulations arguably apply to this situation, they provide no real explication of what constitutes discrimination in this context. I believe the most reasonable approach to giving content to the State's duty is to view it as analogous to the requirements explicitly established in the Section 504 regulations for federally-assisted private education programs (34 C.F.R. S 104.39).
- d. Under these standards, the private schools are "not required to provide an appropriate education to handicapped students with special educational needs" where the schools do not offer programs designed to meet their needs (34 C.F.R. Part 104, App. A at 78). A private school would not be allowed to exclude a handicapped student "able to participate in the program with minor adjustments in the way the program is normally offered" (*id.*).
3. The Notice of Intent to Participate in the Milwaukee Parental Choice Program, in stating requirements of Federal law with which participating schools must comply, has exceeded the requirements of the EHA and Section 504. Sections II.4 and III purport to establish standards that the schools have to assure that they will meet in serving handicapped children under the EHA and Section 504. Because these children are parentally placed under the

Page 3 - The Under Secretary

EHA, the EHA is largely inapplicable. The DPI requirements under Section 504 track both the EHA and the Section 504 provisions applicable to public rather than private education, and as a result impose far more extensive requirements than I conclude are appropriate.

III. Background

In the interest of brevity, I am not going to provide a lengthy description of the Milwaukee Choice Program; it is contained in the attachment at Tab A. For our purposes here, it is sufficient to highlight a couple of points. First, the program is structured so that the State subsidizes private school placements of former public school students to the not insubstantial tune of \$2,500 per capita. Second, these funds appear to come out of a State appropriation without commingling of Federal funds. Third, the program on its face sets few limitations on the private schools that can participate. Fourth, which school a participating student attends is a function of the parent's choice, not a matter of SEA or LEA selection.

The statute defines eligible students in terms of family income and contains no exclusion of handicapped children. The private schools are to choose among their applicants on a random basis. It is unclear in the statute whether a private school could reject an applicant needing special services that it does not normally provide or could charge for these additional services. In any case, we can assume that private schools were intended to retain flexibility to control the content and execution of their own programs and to remove students failing to meet their standards.

In administering the Program, the Wisconsin Department of Public Instruction (DPI) has issued to Milwaukee non-sectarian private schools a document entitled "Notice of School's Intent to Participate in Milwaukee Choice," attached at Tab B. If a school agrees that it will comply with all the requirements contained in the form, then the DPI will find the school to be eligible under the Program. Conversely, refusal to complete the form will result in a finding of ineligibility.

There are two provisions relevant to Section 504 and the EHA. Section II, entitled Student Rights, requires in subsection 4 that the school guarantee that it will comply with Section 504's prohibition of discrimination on the basis of handicap. The subsection adds "[f]or educational obligations for handicapped students see Section III-Handicapped Students."

Section III, in turn, is stated to be applicable if "any of the students applying for admittance to your school under this program are handicapped. Because the potential exists for handicapped students to be involved in this program, the school must meet the following requirements for handicapped students." The following

Page 4 - The Under Secretary

requirements" appear to address EHA requirements, as if the enrollment of the child in the private school were an LEA placement for the purpose of providing special education. Among other things, the schools would be obligated to provide all children with exceptional educational needs (i.e., special education) a free and appropriate public education, including necessary supportive and related services.

The schools also would have to commit to complying with all Section 504 provisions applicable to preschool, elementary, and secondary education programs receiving Federal assistance, except, ironically, section 104.39 "private education programs." In short, it seems fair to say that with respect to handicapped students the DPI equates the obligations of the participating private schools to those of a federally-assisted public school.

IV. The EHA*

Part B of the EHA, 20 U.S.C. 1400 et seq., requires that States, like Wisconsin, and local school districts in Wisconsin, receiving Federal funds under the Act, make available a free appropriate public education (FAPE) to all children within the State. Wisconsin was clearly meeting this requirement prior to implementation of the Choice Plan and would equally clearly be meeting it after implementation, whether or not the private schools are subject to the EHA requirements. State agencies, like DPI, administering the EHA program are not, however, required to pay for the education of handicapped children who are "parentally placed" in private schools. 34 C.F.R. 300.403. Such children are not entitled to FAPE.

Parental placements can be contrasted with "public agency placements" in which a public agency places a child in a private school or facility in order to provide special education and related services. 34 C.F.R. 300.400. In this latter situation the relationship between the public agency and the private school or facility is contractual, with the handicapped child entitled to FAPE and all attendant rights and procedures. The private school becomes the mechanism through which the public agency fulfills its

* The information in this section is largely taken from several memoranda attached at Tab C. OGC and OSERS have indicated orally that they agree with my legal conclusion that children placed by their parents in a private school participating in the Milwaukee Choice Program should be considered "parentally placed."

Page 5 - The Under Secretary

obligation to the child and the public agency (or agencies) pays the full cost of the placement. The children and their parents have the same rights they would have if the children were educated directly by the public agency. 34 C.F.R. 300.401(b).

If FAPE was otherwise available to the children and the parents elected to place the child in the Milwaukee Choice Program, then the placement would be considered to be a parental placement, not a public agency placement for the purpose of providing FAPE. Therefore, the State would not be required to ensure that private schools chosen by the parents would provide FAPE. Conversely, if the placements of the children under the Program are considered to be public agency placements, then DPI would have to ensure provision of FAPE either by contract with the private school, such as through obtaining the sorts of commitments required by the "Notice of School's Intent to Participate" form issued by DPI, or by DPI directly.

Despite the fact that the State is partially subsidizing the placement in private school of any handicapped child who participates in the Program, the fact that it is the parent or parents who are making the unilateral decision to place their child in private school despite the availability of FAPE in the public schools renders these placements "parental placements," in my view. Unlike public agency placements that are made through the IEP process and where the LEA has the controlling role in determining that the child needs to attend the private school or facility, as with other parental placements in the Milwaukee Program the key decisionmaker is the parent(s). Consequently, I conclude that DPI is not required by the EHA to ensure that FAPE is provided to any handicapped child placed by his or her parents in the private school through the Milwaukee Choice Program.

This does not mean, however, that DPI and the Milwaukee Public Schools, the relevant LEA, do not have residual duties vis-a-vis handicapped children who attend those private schools, whether under the auspices of the Program or otherwise. The EHA and the Department's EDGAR regulations require that the SEA and the LEA ensure that "equitable services" are provided to private school students. 34 C.F.R. 300.403 (EHA); 34 C.F.R. 76.650 - 662 (EDGAR); see also the OSERS memorandum attached at Tab D. The "equitable services" requirement does not, however, entitle parentally placed children to the full range of EHA-B services that they would receive if they were entitled to FAPE, nor does it require the Milwaukee LEA to serve all children with handicaps enrolled in the Milwaukee Choice Program. Nonetheless, the fact that the EHA contemplates SEA and LEA provision of some services to private school handicapped students further buttresses the conclusion that state support for the parentally placed students does not convert their private school placement into a public agency placement. This fact also may tend to ameliorate any deterrent effect that the lack of a FAPE requirement might have on

Page 6 - The Under Secretary

Milwaukee parents considering participation for their handicapped children in the Choice Program.

V. Section 504

A. Direct Coverage

The legal issues involving Section 504's applicability to the Milwaukee Choice Plan are, not surprisingly, considerably more difficult and complex than those involving the EHA. This is in part due to the fact that Section 504 is a much more general statute than the EHA and in part due to the uncertain effect of the Civil Rights Restoration Act of 1987, an Act riddled with ambiguity but which directly addresses coverage issues. Section 504's generality is remedied to some extent by fairly detailed Departmental regulations, but despite the regulations' greater specificity they do not, and cannot be expected to, address every possible permutation of federally-assisted programs or activities. Although the Department has dealt with several issues related to Choice plans among public schools, neither the Department nor OCR has dealt with a Choice plan involving private schools. Indeed, there is very little Section 504 law or policy involving private schools in general at the elementary and secondary levels, presumably because these schools are rarely grantees/recipients of Federal funds. In short, we are navigating in largely uncharted waters.

I consider first whether the private schools that would like to participate in the Choice Program should be considered to be recipients of Federal funds and thus directly subject to Section 504 coverage. If the answer to this inquiry is affirmative, one would then have to answer whether the schools should be considered to be operating private education programs, in which case section 104.39 of the Section 504 regulations is applicable, or public elementary and secondary programs, in which case the rest of Subpart B of the regulations would apply (§§ 104.31 - 38). Finding the schools to be one sort of recipient or the other would resolve the issue without having to consider the much murkier question of whether they have indirect obligations through receipt of State money from the State agency recipients.

Unfortunately for the length of this memorandum, these private schools would not be recipients of Federal funds. "Recipients" are defined in section 104.3(f) as including private agencies to which Federal financial assistance is provided directly or through another recipient, such as the SEA (DPI). The State statute creating the Program, however, appears to fund the tuition reimbursements from a State appropriation (see S 199.23(4) of the Milwaukee parental choice program statute in Tab A). Absent a commingling of Federal monies into the appropriations, it appears that the schools are not subrecipients (i.e., indirect recipients) of Federal funds.

Page 7 - The Under Secretary

The Civil Rights Restoration Act does not affect this analysis. No legislative language was changed regarding receipt of Federal funds, nor was any change apparently intended. For example, the Senate Report on its bill, S. Rep. 100-64, 100th Cong., 1st Sess. at 28 (1987), in addressing "matters not affected by the bill," asserts that "The bill does not change in any way who is a recipient of federal financial assistance." The Report then makes specific reference to our Section 504 regulations treatment of private schools as nonrecipients where their students participate in certain federally-funded programs. Given our assumption that the Milwaukee Choice Plan is an exclusively State-funded program, the conclusion is inescapable that the private schools are not recipients directly subject to our regulations. Nor, by virtue of the longstanding Departmental policy referenced by the Committee Report, would they become recipients if their handicapped students received some benefits from the EHA via the SEA and LEA's obligations to provide for "equitable services" for private school handicapped students. (That OCR applies this policy to Section 504 is evidenced by the Section 504 regulations themselves, 34 C.F.R. Part 104, App. A, paragraph 1. The Policy itself was announced with respect to Title VI and published in the Federal Register. See 41 Fed. Reg. 35553 (August 23, 1976) (a copy is attached at Tab E)).

Reinforcing our conclusion that the Civil Rights Restoration Act did not intend to render the private schools recipients of Federal funds, despite the fact that they receive funds from a recipient, is another statement in the Senate Report about subreciprocity:

For State and local governments, only the department or agency which receives the aid is covered. Where an entity of State or local government receives federal aid and distributes it to another department or agency, both entities are covered.

S. Rep. 100-64, 100th Cong., 1st Sess. 4 (1987).

Obviously, departments or agencies (or private schools) to which Federal aid is not distributed or transferred were not intended to be covered.

B. Indirect Coverage

Finding that the private schools are not recipients and thus directly subject to Section 504 does not, however, constitute the end of our inquiry. There are several other ways in which the statute and regulations can affect them and arguably justify the approach taken by the DPI in its Notice. First among these is whether the private schools should be viewed as contractors with the State agency. This is the Section 504 analog to the question

Page 8 - The Under Secretary

under the EHA of whether the placements in the private schools would be "public agency placements." Similar to the conclusion under the EHA that these would be "parental placements" and not public agency placements, we reach a parallel conclusion under Section 504 - the private schools are not contractors.

State agency recipients, such as DPI, are prohibited from discriminating both directly against qualified handicapped persons and indirectly through contractual, licensing, or other arrangements. 34 C.F.R. 104.4(b)(1) and (4). Thus, when an LEA satisfies its obligation to provide FAPE under Section 504 and the EHA by placing a handicapped student in a private school, the LEA is responsible for the full cost of the placement and for ensuring that the private school cooperates in any way necessary. 34 C.F.R. 104.33(b)(3). These arrangements are contractual, and the LEA is required to bind the contractor in such a way that the rights of the student are preserved. The contractor's duties to the student flow from the contract with the LEA, and the contractor does not become a recipient or subrecipient, since any Federal funds it "receives" are received pursuant to a procurement of services contract, which is excluded from the definition of Federal financial assistance. 34 C.F.R. 104.3(h). (DPI seems to be following this approach in the Notice, by seeking to force the private schools to commit to doing all the things an LEA or private contractor would have to do for a public agency placement.) Where, however, a handicapped student's parents voluntarily place him or her in a private school after the LEA has made FAPE available within its public school system, the LEA has no obligation to pay for the placement under Section 504 just as under the EHA. 34 C.F.R. 104.33(c)(4). OCR has extended this rationale to parental placements in state schools as well. See the OCR memorandum dated July 22, 1988 re the Colorado School for the Deaf and Blind, attached at Tab E. In that policy guidance OCR held that transportation costs for students placed by their school districts were a public responsibility (the state school agreed to pay), while the costs for students placed by their parents were the parents' responsibility.

The Milwaukee Choice Program does not appear to involve or contemplate a contractual relationship between the SEA or LEA and the private schools. On the contrary, the statute seems to create an entitlement for the participating students to have the SEA pay their tuition in the private schools. Unlike the situation with public agency placements under the EHA and Section 504, the parents are the operative decisionmakers and no LEA participation is involved.

Another way besides a contractual relationship in which Section 504 can affect the private schools is discussed in the excerpt from the Section 504 regulations Appendix included in the Senate Report on the Civil Rights Restoration Act:

Page 9 - The Under Secretary

One comment requested that the regulation specify that nonpublic elementary and secondary schools that are not otherwise recipients do not become recipients by virtue of the fact their students participate in certain federally funded programs. The Secretary believes it unnecessary to amend the regulation in this regard, because almost identical language in the Department's regulations implementing title VI and title IX of the Education Amendments of 1972 has consistently been interpreted so as not to render such schools recipients. These schools, however, are indirectly subject to the substantive requirements of this regulation through the application of section 104.4(b)(iv), which prohibits recipients from assisting agencies that discriminate on the basis of handicap in providing services to beneficiaries of the recipients' programs.

S. Rep. 100-54, 100th Cong. 1st Sess. 28 (1987). The Report states that this approach would not be affected by the Senate bill, which formed the basis for the Civil Rights Restoration Act. OGC (see the first memorandum in Tab C) and I agree that the Appendix reference is a typographical error and that the correct reference is to section 104.4(b)(1)(v) of the Section 504 regulations. That provision states that a recipient may not, on the basis of handicap, "aid or perpetuate discrimination against a qualified handicapped person by providing significant assistance to an agency, organization, or person that discriminates on the basis of handicap in providing any aid, benefit, or service to beneficiaries of the recipients program."

As noted previously, the Appendix A reference to the prior interpretation is to the 1976 Report on Nonpublic Schools Participating in Federal Programs, published in the Federal Register and attached at Tab E. This Report states that where a private school is not a recipient but "seeks eligibility for its students to participate in the federally-assisted program of the public institution," OCR does not require an assurance of compliance from the private school. Instead, OCR requires that the recipient entity make sure that no discrimination occurs in the federally-assisted program by ensuring that no discriminatory practices occur in the private school, because these would directly affect the federally-assisted program.

If the private school students at schools that would like to participate in the Choice Program are already or will at some future date participate in one or more federally-assisted programs operated by DPI or the LEA, such as the "equitable services" provided under the ERA, then both the approach discussed in the Report and the "significant assistance" provision of the Section 504 would clearly come into play. At this point, however, we do not know if the schools presently have such links, and whether they will in the future is speculative. Even if we knew, we would have

Page 10 - The Under Secretary

to answer the subsequent question of what constitutes the "discrimination" that the private schools must be prevented from engaging in. The subpart of the Section 504 regulations dealing with elementary and secondary education programs contains a specific standard for private education programs receiving Federal funds (34 C.F.R. 104.39) that differs radically from the obligations of similar public programs. Except where such private programs are special education programs themselves, the private schools have much more limited obligations than public programs. They are not subject to 104.32 "Location and Notification," 104.33 "FAPE," 104.35 "Evaluation and Placement" and 104.36 "Procedural Safeguards," which are major components of Section III of the DPI Notice. It requires private schools to sign, except where compliance with 104.33, 104.35, and 104.36 would constitute only "minor adjustments" to their programs. Unless the private schools are already operating special education programs, it is extremely doubtful whether compliance with these requirements could be accomplished with only "minor" adjustments.

Under the significant assistance provision, whereby we indirectly impose Section 504 obligations on nonrecipient private schools, I see no colorable argument for finding that such indirectly affected schools should be held to a stricter nondiscrimination standard than a recipient private school directly assisted by Federal funds. The rationale behind considering the private schools not to be recipients themselves when their students participate in Federal assistance programs appears to be based on congressional intent that the assistance is for the benefit of the private school students and not the private schools they attend. This, of course, contrasts with the postsecondary student assistance program involved in Grove City v. Bell, 465 U.S. 555 (1984), which the Court said was designed to aid colleges and universities, as well as students. I fail to see why when only the students are intended to benefit from the assistance and do so by participating in the Federal program, that their school should be subjected to stricter requirements than when the aid goes directly to the school and thus can be said to benefit all of its students. In the absence of some persuasive reason I have overlooked, I believe the "significant assistance" obligation imposed on private schools indirectly by federally-assisted public agencies should not exceed those in section 104.39.

I have concluded that the private schools are not recipients themselves, and that if their students participate in federally-assisted LEA activities such as EHA "equitable services," the LEA would not be justified in imposing nondiscrimination requirements going beyond the standards contained in 34 C.F.R. 104.39 applicable to private education programs. It remains to be seen whether Section 504 requires the SEA (DPI) to impose the sorts of requirements that it has imposed in its Notice to the private schools. This question involves the most difficult issues that we must face.

Page 11 - The Under Secretary

The first part of this question is whether Section 504 applies to the SEA's activities in setting up and administering the Choice Program, given the fact it does not appear to be using Federal funds for this activity. Section 504's coverage is limited to programs and activities receiving Federal funds, so a serious issue arises as to whether Section 504 applies to the SEA's actions, let alone requires the SEA to indirectly impose all of Section 504's requirements on the private schools. Not without serious misgivings, I conclude that Section 504 does apply to the SEA's actions.

State and local governments have long had programs of aid to students in private and even parochial schools. At the elementary and secondary levels they have provided free textbooks and transportation and at the postsecondary level scholarships and stipends not unlike the aid involved in the Milwaukee Choice Plan. To the best of my knowledge, OCR has never asserted jurisdiction over these State and local activities. Nor has it sought to indirectly regulate the schools the students attend by telling the State and local governments to assure nondiscrimination on the part of the schools. I think it is a reasonable assumption that the reason OCR did not assert jurisdiction was that it did not consider the private programs to be federally funded programs or activities. The nearest analogous situation I can think of is the Department of Justice's opposition to letting school districts fund private school placements for public school students after the district had unconstitutionally segregated its public schools and then closed them to avoid desegregation. Griffin v. County School Board of Prince Edward County, 377 U.S. 218 (1963). This action is readily distinguishable in that, among other things, the school districts were in a remedial posture, having previously violated the constitutional rights of students. They were thus under an affirmative obligation to desegregate their schools, an obligation that conflicted with establishing a new program intentionally aimed at subverting their remedial duty.

Moreover, although the Section 504 regulations lack a definition of "program," the Title VI regulations contain one at 34 C.F.R. 100.13(g), which OCR has always looked to in dealing with program definition issues. Though hardly a model of clarity, when read as a whole it is hard to read this definition as including a State-funded choice program. Nor do related Title VI sections implicitly addressing coverage, such as section 100.4, "Assurances required," and section 100.5, "Illustrative examples," appear to imply coverage of such programs.

Consequently, I seriously doubt whether prior to both the Grove City and the Civil Rights Restoration Act OCR would have asserted jurisdiction over the State's actions in creating the Milwaukee Choice Plan. The Restoration Act, however, contains a very broad definition of the programs or activities covered by Section 504. Under this definition "program or activity" means "all the

Page 12 - The Under Secretary

operations of a department . . . any part of which is extended Federal financial assistance."

Read literally, this seems to cover the State's action in creating and operating the Choice Program, since it would appear to be an "operation" of a department a part of which is receiving Federal funds. Thus, we may be facing a situation where, ironically, the title, "The Civil Rights Restoration Act," may be misnomer, in that the Act does more than just restore pre-Grove City coverage; it may have expanded it substantially. Notwithstanding the fact that the legislative history of the Act, as well as the title, suggest that it was intended solely to restore coverage, I do not believe that we are at liberty to disregard the literal language of the new definition of program or activity in favor of continuing prior approaches. Discrepancies between the proposed new Act and past agency interpretations were thoroughly aired, and the new language was drafted with considerable attention, over several sessions of Congress. While Congress may have been wrong about whether the new definition comported with past practice, and some of the opponents of the bill right about the discrepancy, the proponents appear to have clearly intended the literal scope of the definition and this intention controls. See Brown v. GSA, 425 U.S. 820, 829 (1976) ("[T]he relevant inquiry is not whether Congress correctly perceived the then current state of the law, but rather what its perception of the state of the law was.")

Having concluded that the State's actions in creating and administering the Choice Program are subject to Section 504 as a part of a program or activity receiving federal funds, the question now becomes what obligation does Section 504 impose. Nothing in the Section 504 regulations directly addresses how a State must regulate entities to which it extends its own funds. Section 104.46(b)(1)(v), the "significant assistance" provision discussed on page 10, prohibits DPI from providing significant assistance to an organization that "discriminates," but does not further elaborate on what constitutes discrimination. As noted previously, the provisions of Subpart D, which specifically addresses preschool, elementary, and secondary education, are all framed in terms of a recipient that operates such programs, and the private schools would not be recipients. If they were, we earlier concluded they would be subject to section 104.39 on private education programs. I think it makes sense, in this situation as well, one not anticipated by the drafters of the original regulations, to interpret the general prohibitions of Subpart A contained in section 104.4 to impose on the State agency recipient, DPI, the obligations of ensuring that any private schools receiving State funds comply with the standards applicable to private schools receiving Federal assistance directly from the Federal government, with respect to Choice Program students. In other words, DPI should require assurances that the private schools will comply with section 104.39, rather than the other provisions of Subpart D, as it currently does in its Notice.

Page 13 - The Under Secretary

I recognize that one can argue that the Milwaukee Choice Plan has the effect of discriminating against otherwise qualified handicapped students, in violation of section 104.4(b)(iii). That provision forbids a recipient from providing qualified handicapped students with a benefit that is not as effective as that provided others. Thus, while on its face the Plan does not exclude any handicapped students, if the private schools are not required to provide FAPE and meet all other standards applicable to the public schools, certain handicapped students will likely be unable to take advantage of the program because the private schools will not provide the necessary special services they need. (Other handicapped students, of course, will be able to use the Program because they will not need such services, or because the LEA will provide them under its EHA equitable services obligations, or because the parents will now be able to afford them, since tuition will be free.)

This same argument can be made against many activities of a State or local education agency like DPI, which points up the need to be cautious in applying section 104.4(b)(iii). LEAs offer gifted and talented programs that by their very nature exclude in effect classes of handicapped children. They offer interscholastic athletics programs that exclude in effect other classes of handicapped children from certain activities. States provide higher education scholarships that in effect exclude certain handicapped children. Frequently, we justify these exclusionary effects by finding the availability of other similar activities. Certainly where the public schools remain ready, willing, and able to provide a free appropriate public education to any handicapped student unable to utilize the Program because of a need for special services, we should hesitate to create impediments to a Program of potentially great benefit to large numbers of handicapped and nonhandicapped children alike.

The Supreme Court's decision in Alexander v. Choate, 469 U.S. 287 (1985), also counsels caution in applying the "equally effective" requirements of the Section 504 regulations. In that case, the Supreme Court considered allegations whether a State's limitation of medicaid reimbursement to 14 days discriminated against handicapped persons, since handicapped persons were alleged to be more likely to need more days. Although the Court assumed that Section 504 could reach "at least some conduct that has an unjustifiable impact upon the handicapped" (469 U.S. at 300), the Court specifically found that the facially neutral provision of 14 days to everyone provided handicapped persons meaningful access and did not exclude them from the medicaid services.

In reaching its conclusion, the Court acknowledged that a variety of the Section 504 prohibitions "read in isolation" could be taken to suggest the medicaid program required equal results for handicapped persons. The Court found instead that the proper focus of the regulations was on an equal opportunity to benefit and that

Page 14 - The Under Secretary

the State did not have to redefine the benefit it offered simply to meet the reality that the handicapped have greater medical needs. 469 U.S. at 104.

Wisconsin's Program providing \$2,500 tuition reimbursement per child provides meaningful access to private education to handicapped children and does not exclude them. Especially when viewed in conjunction with the State's ongoing responsibility to make far more extensive services available through its public school programs, offering an equal benefit should not be viewed as discrimination, provided the requirements of section 104.39 are imposed on the private schools. This would ensure that any decisions that the private schools make do not exclude a qualified handicapped student if, with minor adjustments, the student can be provided an appropriate education.

VI. CONCLUSION

Although neither issue is crystal clear, it appears: (1) that the ENA does not cover placements effected by parents participating in the Milwaukee Choice Program; and (2) that the Section 504 regulations should be interpreted as indirectly subjecting the private schools to the requirements respecting private education programs (34 C.F.R. 104.39). The obligations DPI seeks to impose on the private schools wishing to participate in the Program go well beyond section 104.39, and to the extent that they do they are not necessitated by Federal law.

Attachments
As stated

Chairman ROKITA. So, again, when parents have a choice, I truly believe every kid has a chance, and that's what this hearing is about. It was said earlier in this hearing that we tend, up here and in the Federal Government, generally to overcomplicate things.

Ms. Carter, I believe you can make the best choice for your child, as you did, just as Kathy and I can make a great choice for our Teddy and his little brother Ryan. Teddy, by the way, has Angelman syndrome, which is a sister syndrome to what your boy has. So please know, I walk in your shoes on a lot of this stuff, but I truly believe that we can decide for Teddy what is best for him and have the options. And I also understand how difficult it is to get information sometimes. And if I had time to question Ms. Cherry, I'd ask how she found out the information in more detail, because I think that is very important. When parents have a choice, kids have a chance.

So this discussion is going to continue. We're emboldened with the opportunity of having a partner in the White House and the Department of Education who can see that same value proposition and could help us direct more funds, so that parents do have that choice.

Seeing no other business before the committee, we'll stand adjourned. Thank you.

[Additional submission by Mr. Rokita follows:]

#Schoolchoice by the Numbers

- 70%** of Americans support school choice.
- 3,000,000** students attend public charter schools.
- Nearly **400,000** students take advantage of a private school choice program nationwide.

edworkforce.house.gov

[Questions submitted for the record and their responses follow:]



COMMITTEE ON EDUCATION
AND THE WORKFORCE
U.S. HOUSE OF REPRESENTATIVES
2176 RAYBURN HOUSE OFFICE BUILDING
WASHINGTON, DC 20515-6100

MAJORITY MEMBERS:
VIRGINIA FOXX, NORTH CAROLINA, *Chairwoman*
JOE WILSON, SOUTH CAROLINA
DUNCAN HUNTER, CALIFORNIA
DAVID P. ROE, TENNESSEE
GLENN 'GT' THOMPSON, PENNSYLVANIA
TIM WALBERG, MICHIGAN
BRETT GUTHRIE, KENTUCKY
TODD ROOSTA, INDIANA
LOU BARLETTA, PENNSYLVANIA
LURE MESSERS, INDIANA
BRADLEY BYRNE, ALABAMA
DAVID BRAY, VIRGINIA
GLENN GROTHMAN, WISCONSIN
STEVE RUSSELL, OKLAHOMA
ELISE STEFANIK, NEW YORK
RICK W. ALLEN, GEORGIA
JASON LEWIS, MINNESOTA
FRANCIS ROONEY, FLORIDA
PAUL MITCHELL, MICHIGAN
TOM GARNETT, JR., VIRGINIA
LLOYD A. SMACHER, PENNSYLVANIA
A. DREW FERGUSON, IV, GEORGIA

MINORITY MEMBERS:
ROBERT C. 'BOBBY' SCOTT, VIRGINIA,
Ranking Member
SUSAN A. DAVIS, CALIFORNIA
RUSL M. SRINIVASA, ARIZONA
JOE COURTNEY, CONNECTICUT
MARCIA L. FUDGE, OHIO
JARED POLUE, COLORADO
GREGORIO KELLI DAMACHO BAGLAN,
NORTHERN MARIANA ISLANDS
FREDERICA S. WILSON, FLORIDA
SUZANNE BORMARO, OREGON
MARK TAKANO, CALIFORNIA
ALAN S. ADAMS, NORTH CAROLINA
MARK DESALVINES, CALIFORNIA
DONALD NORCROSS, NEW JERSEY
LISA KLINTY ROCHESTER, DELAWARE
RAJA KRISHNAMOORTHY, ILLINOIS
CAROL SHEA-PORTER, NEW HAMPSHIRE
ADRIANO ESPAILLAT, NEW YORK

March 9, 2017

Mrs. Nina Cherry
1316 Rowantree Drive
Dover, FL 33527

Dear Mrs. Cherry:

Thank you, again, for testifying at the February 2, 2017, hearing entitled "Helping Students Succeed Through the Power of School Choice."

As a follow-up to the hearing, please find enclosed a few additional questions that I have. Please provide written responses no later than Thursday, March 30, 2017, for inclusion in the final hearing record. Responses should be sent to the Education Legislative Assistant, Sheariah Yousefi, who can be contacted at (202) 225-6558.

We greatly appreciate your contribution to the work of the Subcommittee.

Sincerely,

Todd Rokita
Chairman
Subcommittee on Early Childhood,
Elementary, and Secondary Education

Enclosure

Chairman Rokita (R-IN)

1. In your testimony you talked about how the school your children are now enrolled in holds them to high expectations and has a culture of high achievement. How does the school foster that culture?
2. If your children had the opportunity to testify before the Subcommittee, what would they have told us about their experiences?
3. Many critics argue school choice programs lack accountability and proper oversight. Could you explain the accountability components in the Florida Tax Credit Scholarship program?



COMMITTEE ON EDUCATION
AND THE WORKFORCE
U.S. HOUSE OF REPRESENTATIVES
2176 RAYBURN HOUSE OFFICE BUILDING
WASHINGTON, DC 20515-6100

MAJORITY MEMBERS:
VIRGINIA FOXX, NORTH CAROLINA, *Chairman*
JOE WILSON, SOUTH CAROLINA
DUNCAN HUNTER, CALIFORNIA
DAVID P. ROE, TENNESSEE
GLENN "OT" THOMPSON, PENNSYLVANIA
TOM WALBERG, MICHIGAN
BRETT GUTHRIE, KENTUCKY
TODD ROKITA, INDIANA
LOU BARLETTA, PENNSYLVANIA
LURE MESSER, INDIANA
BRADLEY SPYNE, ALABAMA
DAVID BRAT, VIRGINIA
GLENN GROTHMAN, WISCONSIN
STEVE RUSSELL, OKLAHOMA
EJURE STEFANIK, NEW YORK
RICK W. ALLEN, GEORGIA
JASON LEHR, MINNESOTA
FRANCIS ROONEY, FLORIDA
PAUL MITCHELL, MICHIGAN
TOM CARRIE, JR., VIRGINIA
LLOYD K. SMUCKER, PENNSYLVANIA
A. DREW FERRELSON, W. GEORGIA

MINORITY MEMBERS:
ROBERT C. "BOBBY" SCOTT, VIRGINIA, *Ranking Member*
SUSAN A. DAVIS, CALIFORNIA
RAUL M. GRIJALVA, ARIZONA
JOE COURTNEY, CONNECTICUT
MARCIA L. FUDGE, OHIO
JARED POLIS, COLORADO
GREGORY KALLI CAMACHO BABLAN, NORTHERN MARIANA ISLANDS
FREDERICA S. WILSON, FLORIDA
SUZANNE BONAMICI, OREGON
MARK TAKANO, CALIFORNIA
ALMA S. ADAMS, NORTH CAROLINA
MARK DESJARDIS, CALIFORNIA
DONALD NORCROSS, NEW JERSEY
LISA BLUNT ROCHSTER, DELAWARE
RAJA KRISHNAMCORTHY, ILLINOIS
CAROL SHEA-PORTER, NEW HAMPSHIRE
ADRIANO ESPALLAT, NEW YORK

March 9, 2017

Mr. Kevin Kubacki
Executive Director
The Neighborhood Charter Network
3725 Kiel Avenue
Indianapolis, IN 46224

Dear Mr. Kubacki:

Thank you, again, for testifying at the February 2, 2017, hearing entitled "Helping Students Succeed Through the Power of School Choice."

As a follow-up, please find enclosed an additional question submitted by a member of the Subcommittee after the hearing. Please provide written responses no later than Thursday, March 30, 2017, for inclusion in the final hearing record. Responses should be sent to the Education Legislative Assistant, Sheariah Yousefi, who can be contacted at (202) 225-6558.

Sincerely,

Todd Rokita
Chairman
Subcommittee on Early Childhood,
Elementary, and Secondary Education

Enclosure

Rep. Bonamici (D-OR)

1. In your testimony, you mention that Enlace Academy, one of the schools your organization manages, is an Innovation Network school, which allows the academy to partner with Indianapolis Public Schools. I'm interested in learning more about this type of partnership. Charter schools are granted autonomy, but that autonomy is only part of the agreement a charter school makes with the district and the state. In exchange, and in keeping with the original intent behind the creation of charter schools, when charters develop new, evidence-based models of teaching and learning, those proven strategies should be communicated to the entire public school system, so they can benefit from the innovation. The *Every Student Succeeds Act* includes a provision I wrote that requires states that receive federal charter school grants to report on the extent to which they are sharing best practices from charter schools with other public schools and the extent to which other public schools are adopting the proven practices developed at charter schools. Can you explain in detail how your organization is identifying and using evidence-based practices and, through its partnership with Indianapolis Public Schools, helping other public schools implement elements of what works in your schools?



COMMITTEE ON EDUCATION
AND THE WORKFORCE
U.S. HOUSE OF REPRESENTATIVES
2176 RAYBURN HOUSE OFFICE BUILDING
WASHINGTON, DC 20515-6100

MAJORITY MEMBERS:
VIRGINIA FOXX, NORTH CAROLINA, *Chairwoman*
JOE WILSON, SOUTH CAROLINA
DUNCAN HUNTER, CALIFORNIA
DAVID P. ROE, TENNESSEE
GLENN "OTTY" THOMPSON, PENNSYLVANIA
TIM WALBERG, MICHIGAN
BRETT GUTHRIE, KENTUCKY
TODD ROKITA, INDIANA
LOU BARLETTA, PENNSYLVANIA
LUCY MESSER, INDIANA
BRADLEY BYRNE, ALABAMA
DAVID BRAT, VIRGINIA
GLENN GROTHMAN, WISCONSIN
STEVE RUSSELL, OREGON
ELISE STEFANK, NEW YORK
RICK W. ALLEN, GEORGIA
JASON LEWIS, MINNESOTA
FRANCIS ROONEY, FLORIDA
PAUL MITCHELL, MICHIGAN
TOM GARRETT, JR., VIRGINIA
LOYD K. BLAGOYEVICH, PENNSYLVANIA
A. DREW FERGUSON, IV, GEORGIA

MINORITY MEMBERS:
ROBERT C. "BOBBY" GLOTT, VIRGINIA,
Ranking Member
SUSAN A. DAVIS, CALIFORNIA
PAUL M. GONCALVES, ARIZONA
JOE COURTNEY, CONNECTICUT
MARCIA L. FUDGE, OHIO
JARED POLSBY, COLORADO
GREGGORY KILLI CAMACHO SABLAN,
NORTHERN MARIANA ISLANDS
FREDERICA S. WILSON, FLORIDA
SUZANNE BONAMICI, OHIO
MARK TAKANO, CALIFORNIA
ALMA S. ADAMS, NORTH CAROLINA
MARK DESALLES, CALIFORNIA
DONALD NORCROSS, NEW JERSEY
LISA BLUNT ROCHSTER, DELAWARE
RAJA KRISHNAMOORTHY, ILLINOIS
CAROL SHEA-PORTER, NEW HAMPSHIRE
ADRIANO ESPALLAT, NEW YORK

March 9, 2017

Mr. Michael L. Williams
Former Commissioner of Education
Texas Education Agency
835 E. Lamar Boulevard
#409
Arlington, TX 76011

Dear Mr. Williams:

Thank you, again, for testifying at the February 2, 2017, hearing entitled "Helping Students Succeed Through the Power of School Choice."

As a follow-up, please find enclosed an additional question submitted by a member of the Subcommittee after the hearing. Please provide written responses no later than Thursday, March 30, 2017, for inclusion in the final hearing record. Responses should be sent to the Education Legislative Assistant, Sheariah Yousefi, who can be contacted at (202) 225-6558.

Sincerely,

Todd Rokita
Chairman
Subcommittee on Early Childhood,
Elementary, and Secondary Education

Enclosure

Rep. Bonamici (D-OR)

1. Thank you for speaking about the rights of students with disabilities. We have made progress, but we still have a long way to go to make sure all students with disabilities reach their full potential. To that end, we must fulfill the requirement that students who need special education services are provided appropriate services immediately—as they are entitled under the *Individuals with Disabilities Education Act* (IDEA). Texas was in the spotlight recently after reports revealed that its state education agency was capping special education services. We know that at least 13 percent of school-aged children receive special education services, yet Texas set an arbitrary cap on special education at only 8.5 percent. After hearing concerns that thousands of students were denied special education in Texas, the U.S. Department of Education sent a letter asking the Texas Education Agency to immediately stop this practice. In your opinion, was this cap a pathway to a high-quality equitable education or did it deprive students of their rights under the IDEA? You advocate for parents to have choice options, but in Texas, parents of students with disabilities did not even have the opportunity to receive an appropriate education in their public school. How do policies like a cap on special education services align with your goal of making sure students have a high-quality, equitable education?

[Mrs. Cherry's response to questions submitted for the record follows:]

1. In your testimony you talked about how the school your children are now enrolled in hold them to high expectation and has a high culture of achievement. How does the school foster that culture?

My husband Demetrius and I have high expectations for our children—both academically and personally—that they rise to. One of the main reasons we chose Tampa Bay Christian for our four children is because the school shares these high expectations and supports all its students in achieving personal excellence. The majority of Tampa Bay Christian's students are receiving Florida's tax-credit scholarship. The school's students have challenges both in school and at home, and the teachers and staff work hard to understand and meet each unique student where they are.

For example, my oldest son is graduating high school next year and is considering college or joining the military. Our school is helping him explore his options, navigate the testing and application processes, and is advising him on opportunities that will best set him up for future success. The school instills in each student that, no matter your circumstances, with hard work you can achieve academic excellence and have a successful life. And my children know that, beyond our family, the Tampa Bay Christian community is here to support them.

2. If your children had the opportunity to testify before the Subcommittee, what would they have told us about their experiences?

We enrolled our children at Tampa Bay Christian with the support of Florida's tax-credit scholarship during an extremely difficult time for our family. At the time, our living situation was completely unstable because of our family's economic struggles. Our kids were strong, but Demetrius and I knew it took a big toll on them. Although we were constantly moving, the scholarship enabled us to choose a community-based school that our children said really felt like home. The stability was crucial for our family.

As parents know, each of our four children are so different—they have unique academic strengths and growth opportunities. My oldest son would tell you how he is excelling in literature and performance at Tampa Bay Christian, while my youngest loves math and would talk about how she's learning her times tables. Our children have different stories of great teachers, academic struggles they've overcome, engaging learning, and strong peer groups. But they would all tell you about their school's focus on academic excellence and driving them to excel; the family environment where they feel safe and valued; and their ability to develop and practice their faith. These priorities make Tampa Bay Christian a great educational fit for our family and all four of our very different children.

3. Many critics argue school choice programs lack accountability and proper oversight. Could you explain the accountability components in the Florida Tax Credit Scholarship program?

Florida tax-credit scholarship students like my children all have to take an annual test assessing them in math and reading. I know that Tampa Bay Christian uses the MAP assessment, which is given on the computer. Our kids' teachers have explained that the computer adjusts the difficulty of the questions as they take the test. I really like that because it personalizes the test for each of my children. My kids' teachers also get their test results quickly, which they use to keep me informed about how my kids are doing and to help my kids learn more throughout the year.

But, most importantly, I totally disagree the argument that parents' choices are not accountable. Demetrius and I are the first, most important teachers in our children's lives—we are their parents. We understand their strengths, challenges and needs better than anyone. Tampa Bay Christian is directly and immediately accountable to Demetrius and me. Like I said in my testimony, if we didn't feel that our school was serving our kids well, we would communicate our concerns to the school. If we decided another school would meet our children's needs better, we would move them to that school and could do so in the middle of the school year. Demetrius and I chose Tampa Bay Christian for our children with careful consideration of what they each needed to be successful and we know our kids are learning and growing there day in and day out. That's accountability.

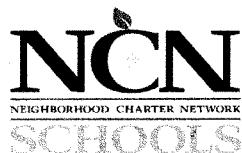

March 10, 2017

Rep. Suzanne Bonamici
U.S. House of Representatives
Subcommittee on Early Childhood
2176 Rayburn House Office Building
Washington, DC, 20515-6100

Dear Rep. Bonamici:

Thank you for your question about the relationship between The Neighborhood Charter Network (NCN) and The Indianapolis Public Schools (IPS). I appreciate your belief that charter schools and traditional public schools can work together, taking collective responsibility for the success of our students.

Our first school, Enlace Academy launched as a grassroots charter school designed to implement a blended learning model that was developed over the course of two years, during which I toured and studied schools around the country that were seeing strong student outcomes as a result of innovative school designs. After Indiana passed HB1321, which allows public school districts to partner with outside organizations, Enlace Academy became a flagship Innovation Network School within IPS. As such, we have access to a district facility and can utilize the economies of scale of the district to buy into other services such as food service or transportation at cost. In exchange, the district counts our student results in their accountability grade from the state. We maintain complete autonomy over our academic program, which allows us to run a proven and innovative school model. Enlace Academy far exceeded the state average for growth points on the state assessments, and we had the fourth highest number of growth points in the IPS district. We were one of only 23% of the schools in Indiana with an A-rating in the state accountability measure. We attribute this success to our model.

As a result of our success, IPS decided to extend our partnership, and they allowed us to restart one of their most academically challenged schools. We have implemented our innovative academic model while adjusting certain aspects of the new school, Kindezi Academy, to meet the specific needs of the community we serve. We launched this year, so we don't have end of year data yet, but we have seen enrollment increase by approximately sixty students from last year, and our winter benchmark data shows that we are on track to double the number of students who pass the state assessment over the previous year.

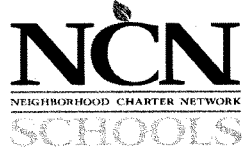

IPS shares our excitement for the gains we are seeing at the two schools, and we are working with their administration to build their understanding of how to implement blended learning in other district schools.

We feel grateful to be working in such a collaborative educational environment, and we are proud to illustrate that district schools and charter schools can coexist and collaborate in the way that you envision in your question.

We would be happy to answer any further questions or host representatives from other states to see the partnership in action.

Thank you,

Kevin Kubacki
Executive Director
The Neighborhood Charter Network

March 17, 2017

The Honorable Todd Rokita
United States Representative
Chairman, Subcommittee on Education and The Workforce
2257 House Office Building
Washington, D.C. 20515

Dear Chairman Rokita,

RE: In response to Representative Bonamici's Request

Thank you for your follow-up question to my testimony at the February 2, 2017 hearing entitled "Helping Students Succeed Through the Power of School Choice."

As you may know, on November 2, 2016, the Texas Education Agency (TEA) responded to the U.S. Department of Education (USDE) October 3, 2016 letter relating allegations presented in a September 11, 2016 newspaper article regarding special education in Texas. In that letter, TEA informed USDE that it did not have any specific evidence to indicate a systematic denial in Texas of special education services to eligible students with disabilities. TEA also confirmed that it never set a cap, limit, or policy on the number or percent of students that districts can, or should serve in special education.

Additionally, TEA described in its November 2, 2016 letter to USDE how its monitoring system is consistent with provisions in the Individuals with Disabilities Act (IDEA) that make clear a child should not be placed in special education unless there is a legitimate academic concern directly attributable to a disability described in 34 CFR §300.8. Indeed, IDEA recognizes the harm caused to students who are improperly placed in special education and encourages states to monitor for potential overrepresentation.

To that end, it is my understanding that TEA is currently in the process of updating its monitoring system to address final regulations issued by USDE on December 19, 2016. Two of the key purposes of these new federal regulations are to (a) ensure children with disabilities are properly identified for services; and (b) address the well-documented and detrimental over-identification of certain students for special education services. USDE believes (Federal Register/Vol. 81, No. 243) that identifying districts for "significant disproportionality" based on specific "thresholds" will lead to better identification, placement, and discipline of children with disabilities. If that is, in fact, the case, then states' implementation of these federal regulations and the corresponding thresholds that are required to be set for special education identification, placement, and discipline, will align with the goal of ensuring all students have a high-quality, equitable education.

Sincerely,



Michael Williams, Former Commissioner
Texas Education Agency

[Whereupon, at 12:14 p.m., the subcommittee was adjourned.]

