

## Coast Guard, DHS

must advise the consumer on the battery replacement schedule which under normal conditions would maintain performance requirements of § 161.013-3.

### § 161.013-17 Manufacturer notification.

Each manufacturer certifying lights in accordance with the specifications of this subpart must send written notice to the Commandant (CG-521), U. S. Coast Guard, 2100 2nd St., SW., Stop 7126, Washington, DC 20593-7126 within 30 days after first certifying them, and send a new notice every five years thereafter as long as it certifies lights.

[CGD 76-183a, 44 FR 73054, Dec. 17, 1979, as amended by CGD 88-070, 53 FR 34536, Sept. 7, 1988; CGD 95-072, 60 FR 50467, Sept. 29, 1995; CGD 96-041, 61 FR 50733, Sept. 27, 1996]

## PART 162—ENGINEERING EQUIPMENT

### Subpart 162.017—Valves, Pressure-Vacuum Relief, for Tank Vessels

Sec.

- 162.017-1 Incorporation by reference.
- 162.017-2 Type.
- 162.017-3 Materials, construction, and workmanship.
- 162.017-4 Inspections and testing.
- 162.017-5 Marking.
- 162.017-6 Procedure for approval.

### Subpart 162.018—Safety Relief Valves, Liquefied Compressed Gas

- 162.018-1 Applicable specifications, and referenced material.
- 162.018-2 Scope.
- 162.018-3 Materials.
- 162.018-4 Construction and workmanship.
- 162.018-5 Blow-down adjustment and popping tolerance.
- 162.018-6 Marking.
- 162.018-7 Flow rating tests.
- 162.018-8 Procedure for approval.

### Subpart 162.027—Combination Solid Stream and Water Spray Firehose Nozzles

- 162.027-1 Incorporation by reference.
- 162.027-2 Design, construction, testing and marking requirements.
- 162.027-3 Approval procedures.

### Subpart 162.028—Extinguishers, Fire, Portable, Marine Type

- 162.028-1 Applicable specifications.
- 162.028-2 Classification.
- 162.028-3 Requirements.
- 162.028-4 Marine type label.

## § 162.017-1

- 162.028-5 Independent laboratories: Listing.
- 162.028-6 Examinations, tests, and inspections.
- 162.028-7 Procedure for listing and labeling.
- 162.028-8 Termination of listing or labeling.

### Subpart 162.039—Extinguishers, Fire, Semiportable, Marine Type

- 162.039-1 Applicable specifications.
- 162.039-2 Classification.
- 162.039-3 Requirements.
- 162.039-4 Marine type label.
- 162.039-5 Recognized laboratory.
- 162.039-6 Examinations, tests, and inspections.
- 162.039-7 Procedure for listing and labeling.
- 162.039-8 Termination of listing or labeling.

### Subpart 162.050—Pollution Prevention Equipment

- 162.050-1 Scope.
- 162.050-3 Definitions.
- 162.050-4 Incorporation by reference: Where can I get a copy of the publications mentioned in this part?
- 162.050-5 Contents of application.
- 162.050-7 Approval procedures.
- 162.050-9 Test report.
- 162.050-11 Marking.
- 162.050-13 Factory production and inspection.
- 162.050-15 Designation of facilities.
- 162.050-17 Separator test rig.
- 162.050-19 Oil content meter and bilge alarm test rig.
- 162.050-20 Separator and bilge alarm test fluids.
- 162.050-21 Separator: Design specification.
- 162.050-23 Separator: Approval tests.
- 162.050-25 Cargo monitor: Design specification.
- 162.050-27 Oil content meter: approval tests.
- 162.050-33 Bilge alarm: Design specification.
- 162.050-35 Bilge alarm: Approval tests.
- 162.050-37 Vibration test.
- 162.050-39 Measurement of oil content.

AUTHORITY: 33 U.S.C. 1321(j), 1903; 46 U.S.C. 3306, 3703, 4104, 4302; E.O. 12234, 45 FR 58801, 3 CFR, 1980 Comp., p. 277; E.O. 12777, 56 FR 54757, 3 CFR, 1991 Comp., p. 351; Department of Homeland Security Delegation No. 0170.1.

### Subpart 162.017—Valves, Pressure-Vacuum Relief, for Tank Vessels

SOURCE: CGFR 50-9, 15 FR 1680, Mar. 25, 1950, unless otherwise noted.

#### § 162.017-1 Incorporation by reference.

(a) Certain material is incorporated by reference into this subchapter with

**§ 162.017-2**

**46 CFR Ch. I (10-1-11 Edition)**

the approval of the Director of the Federal Register under 5 U.S.C. 552(a) and 1 CFR part 51. To enforce any edition other than that specified in this section, the Coast Guard must publish notice of change in the FEDERAL REGISTER and the material must be available to the public. All approved material is available for inspection at the National Archives and Records Administration (NARA). For information on the availability of this material at NARA, call 202-741-6030 or go to [http://www.archives.gov/federal\\_register/code\\_of\\_federal\\_regulations/ibr\\_locations.html](http://www.archives.gov/federal_register/code_of_federal_regulations/ibr_locations.html). The material is also available for inspection at the U.S. Coast Guard, Office of Design and Engineering Standards (CG-521), 2100 2nd St., SW., Stop 7126, Washington, DC 20593-7126, and is available from the sources listed below.

(b) *International Organization for Standardization (ISO)*, Case postal 56, CH-1211 Geneva 20, Switzerland:

(1) ISO 15364, Ships and Marine Technology—Pressure/Vacuum Valves for Cargo Tanks, First Edition (Sep. 1, 2000) (“ISO 15364”), 162.017-3; and

(2) [Reserved]

[USCG-2003-16630, 73 FR 65202, Oct. 31, 2008, as amended by USCG-2009-0702, 74 FR 49238, Sept. 25, 2009]

**§ 162.017-2 Type.**

This specification covers the design and construction of pressure-vacuum relief valves intended for use in venting systems on all tank vessels transporting inflammable or combustible liquids.

[56 FR 35827, July 29, 1991]

**§ 162.017-3 Materials, construction, and workmanship.**

(a) The valves shall be of substantial construction and first class workmanship and shall be free from imperfections which may affect its serviceability.

(b) Bodies of pressure-vacuum relief valves must be made of bronze or such corrosion-resistant material as may be approved by the Commanding Officer, USCG Marine Safety Center.

(c) Valve discs, spindles, and seats shall be made of bronze or such corrosion-resistant material as may be ap-

proved by the Commanding Officer, USCG Marine Safety Center.

(d) Where springs are employed to actuate the valve discs, the springs shall be made of corrosion-resistant material. Springs plated with corrosion-resistant material are not acceptable.

(e) Flame screens shall be made of corrosion-resistant wire.

(f) Nonmetallic materials will not be permitted in the construction of the valves, except bushings used in way of moving parts and gaskets may be made of nonmetallic material resistant to attack by the product carried. Nonmetallic diaphragms will be allowed where diaphragm failure will not result in unrestricted flow of cargo vapors to the atmosphere nor in an increase in the pressure or vacuum at which the valve normally releases.

(g) The design and construction of the valves shall permit overhauling and repairs without removal from the line.

(h) Valve discs shall be guided by a ribbed cage or other suitable means to prevent binding, and to insure proper seating. Where valve stems are guided by bushings suitably designed to prevent binding and to insure proper seating, the valves need not be fitted with ribbed cages.

(i) The disc shall close tight against the valve seat by metal to metal contact, however, resilient seating seals may be provided if the design is such that the disc closes tight against the seat in case the seals are destroyed or in case they carry away.

(j) Pressure-vacuum relief valves for venting cargo tanks shall be of not less than 2½ inches nominal pipe size.

(k) Bodies of valves shall be designed to withstand a hydrostatic pressure of at least 125 pounds per square inch without rupturing or showing permanent distortion.

(l) The valve discs may be solid or made hollow so that weight material may be added to vary the lifting pressure. If hollow discs are employed, a watertight bolted cover shall be fitted to encase the weight material. The pressure at which the discs open shall not exceed 120 percent of the set pressure.

(m) The free area through the valve seats at maximum lift shall not be less

than the cross-sectional area of the valve inlet connection.

(n) Double flame screens of 20×20 corrosion-resistant wire mesh with a ½-inch corrosion-resistant separator on a single screen of 30×30 corrosion-resistant wire mesh shall be fitted on all openings to atmosphere. The net free area through the flame screens shall not be less than 1½ times the cross-sectional area of the vent inlet from the cargo tanks.

(o) Valve bodies may have screwed or flanged pipe connections, or such types of connections as may be approved by the Commanding Officer, USCG Marine Safety Center. If flanged, the thickness and drilling shall comply with USA standards for 150-pound bronze flanged fittings.

(p) Where design of valve does not permit complete drainage of condensate to attached cargo tank or vent line, the valve body shall be fitted with a plugged drain opening on the side of the atmospheric outlet of not less than ½ inch pipe size.

(q) Relief pressure adjusting mechanisms shall be permanently secured by means of lockwires, locknuts, or other acceptable means.

(r) Pressure-vacuum relief valves constructed in accordance with ISO 15364 (incorporated by reference; see 46 CFR 162.017-1) meet the requirements of this subpart.

[CGFR 50-9, 15 FR 1680, Mar. 25, 1950, as amended by CGFR 68-82, 33 FR 18907, Dec. 18, 1968; CGD 88-032, 56 FR 35827, July 29, 1991; CGD 95-072, 60 FR 50467, Sept. 29, 1995; CGD 96-041, 61 FR 50734, Sept. 27, 1996; USCG 2001-10224, 66 FR 48620, Sept. 21, 2001; USCG-2003-16630, 73 FR 65202, Oct. 31, 2008]

#### § 162.017-4 Inspections and testing.

Pressure-vacuum relief valves may be inspected and tested at the plant of the manufacturer. An inspector may conduct such tests and examinations as may be necessary to determine compliance with this specification.

[56 FR 35827, July 29, 1991]

#### § 162.017-5 Marking.

(a) Each valve shall be legibly marked with the style, type or other designation of the manufacturer, the size, pressure and vacuum setting and name or registered trademark of the

manufacturer and Coast Guard approval number. The minimum wording for showing the approval number shall be “USCG/162.017/\* \*\*” or “USCG 162.017-\* \*\*”.

(b) [Reserved]

[CGFR 68-82, 33 FR 18908, Dec. 18, 1968, as amended by USCG 2001-10224, 66 FR 48620, Sept. 21, 2001]

#### § 162.017-6 Procedure for approval.

(a) *General.* Pressure-vacuum relief valves intended for use on tank vessels must be approved for such use by the Commanding Officer, U.S. Coast Guard Marine Safety Center. Applications for approval may be delivered by visitors to the Commanding Officer, U.S. Coast Guard Marine Safety Center, 1900 Half Street, SW, Suite 1000, Room 525, Washington, DC 20024, or transmitted by mail to: Commanding Officer, U.S. Coast Guard Marine Safety Center, 2100 2nd St. SW., Stop 7126, Washington, DC 20593-7126, in a written or electronic format. Information for submitting the VSP electronically can be found at <http://www.uscg.mil/HQ/MS>.

(b) *Drawings and specifications.* Manufacturers desiring approval of a new design or type of pressure-vacuum relief valve shall submit drawings in quadruplicate showing the design of the valve, the sizes for which approval is requested, method of operation, thickness and material specification of component parts, diameter of seat opening and lift of discs, mesh and size of wire of flame screens.

(c) *Pre-approval tests.* Before approval is granted, the manufacturer shall have tests conducted, or submit evidence that such tests have been conducted, by the Underwriters' Laboratories, the Factory Mutual Laboratories, or by a properly supervised and inspected test laboratory acceptable to the Commandant (CG-521), relative to determining the lift, relieving pressure and vacuum, and flow capacity of a representative sample of the pressure-vacuum relief valve in each size for which approval is desired. Test reports including flow capacity curves must be

\* \*\*Number to be assigned by the Commanding Officer, USCG Marine Safety Center.

## § 162.018-1

submitted to the Commanding Officer, USCG Marine Safety Center.

[56 FR 35827, July 29, 1991, as amended by CGD 95-072, 60 FR 50467, Sept. 29, 1995; CGD 96-041, 61 FR 50734, Sept. 27, 1996; USCG 2001-10224, 66 FR 48620, Sept. 21, 2001; USCG-2004-18884, 69 FR 58350, Sept. 30, 2004; USCG-2007-29018, 72 FR 53967, Sept. 21, 2007; USCG-2009-0702, 74 FR 49238, Sept. 25, 2009]

### Subpart 162.018—Safety Relief Valves, Liquefied Compressed Gas

#### § 162.018-1 Applicable specifications, and referenced material.

(a) There are no other specifications applicable to this subpart except as noted in this subpart.

(b) The following referenced material from industry standards of the issue in effect on the date safety relief valves are manufactured shall form a part of the regulations of this subpart (see §§ 2.75-17 through 2.75-19 of Subchapter A (Procedures Applicable to the Public) and Subpart 50.15 of Subchapter F (Marine Engineering) of this chapter):

(1) ASME (American Society of Mechanical Engineers) Code (see § 50.15-5 of subchapter F (Marine Engineering) of this chapter): The following paragraph from section VIII of the ASME Code:

(i) UG-131, flow rating of valves, see § 162.018-7(a).

(2) CGA (Compressed Gas Association) standard: The following standard of the Compressed Gas Association (see § 50.15-20(a) of Subchapter F (Marine Engineering) of this chapter):

(i) S-1.2.5.2, Flow test data for safety and relief valves for use on pressure vessels, see § 162.018-7(a).

(c) A copy of this specification and the referenced material listed in this section, if used, shall be kept on file by the manufacturer, together with the approved plans, specifications, and certificate of approval. It is the manufacturer's responsibility to have the latest issue, including addenda and changes, of the referenced material on hand when manufacturing equipment under this subpart.

(1) The ASME Code may be obtained from the American Society of Mechanical Engineers, United Engineering

## 46 CFR Ch. I (10-1-11 Edition)

Center, 345 East 47th Street, New York, N.Y. 10017.

(2) The CGA standard may be obtained from the Compressed Gas Association, 500 Fifth Avenue, New York, N.Y. 10036.

[CGFR 68-82, 33 FR 18908, Dec. 18, 1968]

#### § 162.018-2 Scope.

(a) This specification covers requirements for the design, construction and testing of safety relief valves intended for use on unfired pressure vessels containing liquefied compressed gases installed on merchant vessels subject to inspection by the Coast Guard.

(b) [Reserved]

[CGFR 52-43, 17 FR 9540, Oct. 18, 1952]

#### § 162.018-3 Materials.

(a) The materials used in the manufacture of safety relief valves shall conform to the applicable requirements of subchapter F (Marine Engineering) of this chapter, except as otherwise specified in this subpart, and shall be resistant to the corrosive or other action of the liquefied compressed gas in the liquid or gas phase.

(b) All pressure containing external parts of valves must be constructed of materials melting above 1700 °F. for liquefied flammable gas service. Consideration of lower melting materials for internal pressure-containing parts will be given if their use provides significant improvement to the general operation of the valve. Flange gaskets shall be metal or spiral wound asbestos.

(c) Nonferrous materials shall not be used in the construction of valves for anhydrous ammonia or other service where susceptible to attack by the lading.

(d) The seats and disks shall be of suitable corrosion resistant material. Seats and disks of cast iron or malleable iron shall not be used. Springs shall be of best quality spring steel consistent with the design of the valve and the service requirement.

[CGFR 52-43, 17 FR 9540, Oct. 18, 1952, as amended by CGFR 68-82, 33 FR 18908, Dec. 18, 1968; CGD 72-206R, 38 FR 17230, June 29, 1973]

**§ 162.018-4 Construction and workmanship.**

(a) Safety relief valves shall be of either the internal or external spring-loaded type, suitable for the intended service.

(b) Safety relief valve body, base, bonnet and internals shall be designed for a pressure of not less than the set-pressure of the valve.

(c) All safety relief valves shall be so constructed that the failure of any part cannot obstruct the free and full discharge of vapors from the valve.

(d) The nominal size of a safety relief valve shall be the inside diameter of the inlet opening to the individual valve disk. No safety relief valve shall be smaller than  $\frac{3}{4}$  inch nor larger than 6 inches. Safety relief valves shall have flanged or welded end inlet connections and either flanged or screwed outlet connections, except outlets exceeding 4 inches in diameter shall be flanged.

(e) Safety relief valves shall be of the angle or straight-through type, fitted with side or top outlet discharge connections.

(f)(1) Springs shall not show a permanent set exceeding 1 percent of their free length 10 minutes after being released from a cold compression test closing the spring solid.

(2) Springs may not be re-set for any pressure more than 10 percent above or 10 percent below that for which the valve is marked.

(3) If the operating conditions of a valve are changed so as to require a new spring under paragraph (f)(2) of this section for a different pressure, the valve shall be adjusted by the manufacturer or his authorized representative.

(g) The design and construction of safety relief valves shall permit easy access for inspection and repair.

(h) Safety relief valves shall be tapped for not less than  $\frac{1}{4}$  inch pipe size drain at the lowest practicable point where liquid can collect.

[CGFR 52-43, 17 FR 9540, Oct. 18, 1952]

**§ 162.018-5 Blow-down adjustment and popping tolerance.**

(a) Safety relief valves shall be so constructed that no shocks detrimental to the valve or pressure vessel are produced when lifting or closing.

Safety relief valves shall be designed to open sharply and reach full lift and capacity at the maximum accumulation. Valve closure after popping shall be clean and sharp. Safety relief valves shall operate satisfactorily without wiredrawing and chattering at any stage of operation.

(b) Safety relief valves having adjustable blow-down construction shall be adjusted to close after blowing down not more than 5 percent of the set pressure. Valves shall be adjusted to pop within a tolerance of plus or minus 3 percent of the set pressure, except that for pressures of 70 p.s.i. and below, the tolerance in popping pressure shall not vary more than plus or minus 2 p.s.i.

[CGFR 52-43, 17 FR 9541, Oct. 18, 1952]

**§ 162.018-6 Marking.**

(a) Each safety relief valve shall be plainly marked by the manufacturer with the required data in such a way that the marking will not be obliterated in service. The marking may be stamped on the valve or stamped or cast on a plate securely fastened to the valve. The marking shall include the following data:

(1) The name or identifying trade-mark of the manufacturer.

(2) Manufacturer's design or type number.

(3) Size \_\_\_ inches. (The pipe size of the valve inlet).

(4) Set pressure \_\_\_ p.s.i.

(5) Rated capacity \_\_\_ cubic feet per minute of the gas or vapor (at 60 °F. and 14.7 p.s.i.a.).

(6) Coast Guard approval number. The minimum wording for showing approval shall be "USCG 162.018/\* \*" or "USCG 162.018-\* \*".

(b) [Reserved]

[CGFR 68-82, 33 FR 18908, Dec. 18, 1968, as amended by USCG 2001-10224, 66 FR 48620, Sept. 21, 2001]

**§ 162.018-7 Flow rating tests.**

(a) Flow rating of valves shall be conducted in accordance with UG-131 of section VIII of the ASME Code, S-

\* \*Number to be assigned by the Commanding Officer, USCG Marine Safety Center.

## § 162.018-8

1.2.5.2 of the Compressed Gas Association Standards, or other procedure approved by the Commanding Officer, USCG Marine Safety Center.

(b) [Reserved]

[CGFR 68-82, 33 FR 18908, Dec. 18, 1968, as amended by USCG 2001-10224, 66 FR 48620, Sept. 21, 2001]

### § 162.018-8 Procedure for approval.

(a) *General.* Safety relief valves for use on pressure vessels containing liquefied compressed gases must be approved by the Commanding Officer, U.S. Coast Guard Marine Safety Center. Applications for approval may be delivered by visitors to the Commanding Officer, U.S. Coast Guard Marine Safety Center, 1900 Half Street, SW., Suite 1000, Room 525, Washington, DC 20024, or transmitted by mail to: Commanding Officer, U.S. Coast Guard Marine Safety Center, 2100 2nd St., SW., Stop 7126, Washington, DC 20593-7126, in a written or electronic format. Information for submitting the VSP electronically can be found at <http://www.uscg.mil/HQ/MS>.

(b) *Plan submittal.* Manufacturers desiring to secure approval of a new design or type of safety relief valve shall submit in quadruplicate detail drawings showing the valve construction, and material specifications of the component parts. In the event the design is changed, amended drawings shall be submitted to the Commanding Officer, USCG Marine Safety Center, for re-approval.

(c) *Pre-approval tests.* (1) Prior to approval of safety relief valves by the Commanding Officer, USCG Marine Safety Center, manufacturers shall have capacity certification tests conducted, in accordance with § 162.018-7 or submit satisfactory evidence that such tests have been conducted and approved by The National Board of Boiler and Pressure Vessel Inspectors or by a properly supervised and inspected test laboratory acceptable to the Commanding Officer, USCG Marine Safety Center.

(2) Reports of conducted tests on designs of safety relief valves different from those previously approved shall be submitted by the manufacturer

## 46 CFR Ch. I (10-1-11 Edition)

when requesting approval for different designs.

[CGFR 52-43, 17 FR 9540, Oct. 18, 1952, as amended by CGFR 68-82, 33 FR 18908, Dec. 18, 1968; CGD 88-070, 53 FR 34536, Sept. 7, 1982; CGD 96-041, 61 FR 50734, Sept. 27, 1996; USCG 2001-10224, 66 FR 48620, Sept. 21, 2001; USCG-2007-29018, 72 FR 53967, Sept. 21, 2007; USCG-2009-0702, 74 FR 49238, Sept. 25, 2009]

### Subpart 162.027—Combination Solid Stream and Water Spray Firehose Nozzles

SOURCE: CGD 95-027, 61 FR 26009, May 23, 1996, unless otherwise noted.

#### § 162.027-1 Incorporation by reference.

(a) Certain material is incorporated by reference into this part with the approval of the Director of the Federal Register under 5 U.S.C. 552(a) and 1 CFR part 51. To enforce any edition other than that specified in paragraph (b) of this section, the Coast Guard must publish a notice of change in the FEDERAL REGISTER and the material must be available to the public. All approved material is available for inspection at the National Archives and Records Administration (NARA) and at the U.S. Coast Guard, Office of Design and Engineering Standards (CG-521), 2100 2nd St., SW., Stop 7126, Washington, DC 20593-7126 and is available from the sources indicated in paragraph (b) of this section. For information on the availability of this material at NARA, call 202-741-6030, or go to: [http://www.archives.gov/federal\\_register/code\\_of\\_federal\\_regulations/ibr\\_locations.html](http://www.archives.gov/federal_register/code_of_federal_regulations/ibr_locations.html).

(b) The material approved for incorporation by reference in this part and the sections affected are as follows:

American Society for Testing and Materials (ASTM)  
100 Barr Harbor Drive, West Conshohocken, PA 19428-2959.

## Coast Guard, DHS

## § 162.028-3

ASTM F 1546 [or] F 1546 M-96, Standard Specification for Firehose Nozzles—162.027-2; 162.027-3

[CGD 95-027, 61 FR 26009, May 23, 1996, as amended by CGD 96-041, 61 FR 50734, Sept. 27, 1996; CGD 97-057, 62 FR 51049, Sept. 30, 1997; USCG-1999-6216, 64 FR 53228, Oct. 1, 1999; USCG-1999-5151, 64 FR 67185, Dec. 1, 1999; 69 FR 18803, Apr. 9, 2004; USCG-2009-0702, 74 FR 49238, Sept. 25, 2009]

### § 162.027-2 Design, construction, testing and marking requirements.

(a) Each combination solid stream and water spray firehose nozzle required to be approved under the provisions of this subpart must be designed, constructed, tested, and marked in accordance with the requirements of ASTM F 1546 (incorporated by reference, see § 162.027-1).

(b) All inspections and tests required by ASTM F 1546 (incorporated by reference, see § 162.027-1) must be performed by an independent laboratory accepted by the Coast Guard under subpart 159.010 of this chapter. A list of independent Laboratories accepted by the Coast Guard as meeting subpart 159.010 of this chapter may be obtained by contacting the Commandant (CG-521).

(c) The independent laboratory shall prepare a report on the results of the testing and shall furnish the manufacturer with a copy of the test report upon completion of the testing required by ASTM F 1546 (incorporated by reference, see § 162.027-1).

[CGD 95-027, 61 FR 26009, May 23, 1996, as amended by CGD 96-041, 61 FR 50734, Sept. 27, 1996; USCG-1999-5151, 64 FR 67185, Dec. 1, 1999; USCG-2009-0702, 74 FR 49238, Sept. 25, 2009]

### § 162.027-3 Approval procedures.

(a) Firehose nozzles designed, constructed, tested, and marked in accordance with ASTM F 1546 (incorporated by reference, see § 162.027-1) are considered to be approved under the provisions of this chapter.

(b) Firehose nozzles designed, constructed, tested and marked in accordance with the provisions of this subpart in effect prior to June 24, 1996, are

considered to be approved under the provisions of this chapter.

[CGD 95-027, 61 FR 26009, May 23, 1996, as amended by USCG-1999-5151, 64 FR 67185, Dec. 1, 1999]

## Subpart 162.028—Extinguishers, Fire, Portable, Marine Type

SOURCE: CGFR 60-36, 25 FR 10640, Nov. 5, 1960, unless otherwise noted.

### § 162.028-1 Applicable specifications.

(a) There are no other Coast Guard specifications applicable to this subpart.

(b) [Reserved]

### § 162.028-2 Classification.

(a) Every portable fire extinguisher shall be classified as to type and size as specified in § 76.50-5 (Subchapter H—Passenger Vessels) of this chapter.

(b) [Reserved]

### § 162.028-3 Requirements.

(a) *General.* Every portable fire extinguisher shall conform to the requirements for listing and labeling by a recognized laboratory, and shall be of such design, materials, and construction as to meet the requirements specified in this section.

(b) *Design and weight.* Every portable fire extinguisher shall be self-contained, i.e., when charged it shall not require any additional source of extinguishing agent or expellant energy for its operation during the time it is being discharged, and it shall weigh not more than 55 pounds, maximum, when fully charged.

(c) *Materials.* Materials used for exposed working parts shall be corrosion-resistant to salt water and spray. Materials used for other exposed parts shall be either corrosion-resistant or shall be protected by a suitable corrosion-resistant coating.

(1) *Corrosion-resistant materials.* The materials which are considered to be corrosion-resistant are copper, brass, bronze, certain copper-nickel alloys, certain alloys of aluminum, certain plastics, and certain stainless steels.

(2) *Corrosion-resistant coatings.* (i) The following systems of organic or metallic coatings for exposed non-working

ferrous parts, when applied on properly prepared surfaces after all cutting, forming, and bending operations are completed, are considered to provide suitable corrosion resistance:

(a) Bonderizing, followed by the application of zinc chromate primer, followed by one or more applications of enamel; or,

(b) Hot-dipped or electrodeposited zinc in thicknesses not less than 0.002 inch; or,

(c) Electrodeposited cadmium in thicknesses not less than 0.001 inch; or,

(d) Hot-dipped or sprayed aluminum in thicknesses not less than 0.002 inch; or,

(e) Copper plus nickel in total thicknesses not less than 0.003 inch, of which the nickel is not less than 0.002 inch, plus any thickness of chrome.

(ii) The metallic platings of less than the thicknesses specified in this paragraph are not acceptable for the protection against corrosion of ferrous parts.

(3) *Decorative platings.* Decorative platings in any thicknesses applied over corrosion-resistant materials and corrosion-resistant coatings are acceptable for either working or non-working parts.

(4) *Dissimilar metals.* The use of dissimilar metals in combination shall be avoided wherever possible, but when such contacts are necessary, provisions (such as bushings, gaskets, or o-rings) shall be employed to prevent such deleterious effects as galvanic corrosion, freezing or buckling of parts, and loosening or tightening of joints due to differences in thermal expansion.

(5) *Suitability of materials.* All extinguishers submitted for approval shall undergo the salt spray test in accordance with paragraph (c)(6) of this section.

(6) *Salt spray tests.* Expose the complete fully charged specimen extinguisher to a 20 percent sodium chloride solution spray at a temperature of 95 °F. (35 °C.) for a period of 240 hours. The procedures and apparatus described in Method 811 of Federal Test Method Standard No. 151 are suitable. Alternate methods may be found satisfactory if the results are comparable. Following the test, allow the specimen ex-

tinguisher to air dry for a period of 48 hours. Following the air drying—

(i) The extinguisher must be capable of being operated and recharged in a normal fashion;

(ii) Any coating required in this section to be corrosion resistant must remain intact and must not be removable (when such removal exposes a material subject to corrosion) by such action as washing or rubbing with a thumb or fingernail;

(iii) No galvanic corrosion may appear at the points of contact or close proximity of dissimilar metals;

(iv) The extinguisher and its bracket, if any, must not show any corrosion, except corrosion that can be easily wiped off after rinsing with tap water, on surfaces having no protective coating or paint; and,

(v) The gauge on a stored pressure extinguisher must remain watertight throughout the test.

(d) *Bursting pressure.* For all extinguishers except the carbon dioxide type, the hydrostatic bursting pressure of the extinguisher and component parts which are subjected to pressure, exclusive of the hose, shall be at least five times the maximum working pressure during discharge of the extinguisher at approximately 70 °F. During this test, a pressure gauge if fitted will usually be removed to avoid breaking the indicating mechanism, but the gauge shall be capable of withstanding the same test without leaking.

(e) *Vibration resistance.* The complete, fully charged specimen extinguisher, secured in its bracket which is mounted to the test machine, shall be tested in accordance with sections 3.1 through 3.1.4.4 of Military Standard MIL-STD-167. Following this test, there shall be no obvious failures of parts or assemblies, and the specimen shall be capable of being operated satisfactorily without undue effort or special procedures on the part of the operator, and the specimen shall be capable of being recharged satisfactorily in accordance with the directions on the name plate without the use of extraordinary tools or procedures.

(f) *Additional marking.* (1) As part of the usual name plate marking, there shall be included the rated capacity of the extinguisher in gallons, quarts, or



pounds, and complete instructions for recharging, including the identification of the recharge materials and of the pressure cartridge or separate container if one is used.

(2) For extinguishers which are not ordinarily discharged or opened during the regular maintenance inspections and tests, the weight of the fully charged extinguisher shall be die-stamped, embossed, or cast in a conspicuous location on the name plate, valve body, or shell of the extinguisher.

(3) Pasted-on type paper or decalcomania labels are not acceptable for any of the required extinguisher markings.

(4) For stored pressure type or cartridge operated type water or anti-freeze portable fire extinguishers, each extinguisher name plate shall be marked to indicate whether the extinguisher is to be filled with plain water or with anti-freeze solution. Combination type name plates showing the charge may be either plain water or antifreeze solution will not be permitted.

(5) Recharge packages shall be legibly marked with the name of the recharge and the capacity of contents in gallons, quarts, or pounds, in addition to the usual recharge package marking. Recharge pressure cartridges shall, in addition to the usual marking, also be plainly marked to show the distinctive identifying designation of the cartridge.

(g) *Mounting bracket.* Every portable fire extinguisher shall be supplied with a suitable bracket which will hold the extinguisher securely in its stowage location on vessels or boats, and which is arranged to provide quick and positive release of the extinguisher for immediate use.

(h) *Carbon dioxide type.* Every carbon dioxide type extinguisher shall be fitted with a valve which will withstand a minimum bursting pressure of 6,000 p.s.i., and a discharge hose or tube which will withstand a minimum bursting pressure of 5,000 p.s.i. The hose shall be constructed with either a wire braid or other conducting material for conducting static charges occurring at the discharge nozzle back to the body of the extinguisher.

(i) [Reserved]

(j) *Dry chemical type.* (1) [Reserved]

(2) Every dry chemical stored pressure type portable fire extinguisher, i.e., one which employs a single chamber for both the dry chemical and expellant gas, shall be fitted with a pressure gauge or device to show visual indication of whether or not the pressure in the chamber is in the operating range.

(k) *Toxic extinguishing agents.* Every portable fire extinguisher shall contain only agents which qualify for the Underwriters' Laboratories, Inc., toxicity rating of Group 5 or Group 6, and which in normal fire extinguishing use do not generate decomposition products in concentrations hazardous to life.

(l) *Gauge.* Every pressure gauge used on a portable fire extinguisher shall have an accuracy of at least 2 percent of the scale range for the middle half of the scale conforming to ASME Grade B commercial accuracy. The gauge when new shall be watertight, i.e., with the connection capped or plugged, no water shall penetrate to the interior of the case during submergence one foot below the surface of water for a period of two hours. The gauge shall be constructed of corrosion-resistant materials, so that the pointer or face lettering will not be obliterated by the action of salt water if some leakage should occur after rough handling or extended periods of service. The gauge, when attached to the fire extinguisher, shall pass the salt spray and vibration tests prescribed by §162.028-3 (c)(1) and (e).

(m) *Fire tests.* In addition to the usual fire tests conducted to determine the suitability and adequacy of portable fire extinguishers, additional fire tests, such as those described in National Bureau of Standards Building Materials and Structures Report 150, issued June 14, 1957, may be employed in determining the suitability for "marine type" listing and labeling.

(n) *Additional tests.* Every portable extinguisher may be additionally examined and tested to establish its reliability and effectiveness in accordance with the intent of this specification for a "marine type" portable fire extinguisher when considered necessary by

#### § 162.028-4

the Coast Guard or by the recognized laboratory.

[CGFR 60-36, 25 FR 10640, Nov. 5, 1960, as amended by CGFR 62-17, 27 FR 9046, Sept. 11, 1962; CGFR 56-28, 29 FR 12726, Sept. 9, 1964; CGFR 64-67, 29 FR 14742, Oct. 29, 1964; CGD 72-214R, 38 FR 6880, Mar. 14, 1973; CGD 73-73R, 38 FR 27354, Oct. 3, 1973]

#### § 162.028-4 Marine type label.

(a) In addition to all other marking, every portable extinguisher shall bear a label containing the "marine type" listing manifest issued by a recognized laboratory. This label will include the classification of the extinguisher in accordance with the Coast Guard classification system, and the Coast Guard approval number, thus: "Marine Type USCG Type \_\_\_\_\_, Size \_\_\_\_\_, Approval No. 162.028/\_\_\_\_\_." All such labels are to be obtained from the recognized laboratory and will remain under its control until attached to product found acceptable under its listing and labeling program.

(b) All such labels are to be obtained only from the recognized laboratory and will remain under its control until attached to product found acceptable under its inspection and labeling program.

[CGFR 60-36, 25 FR 10640, Nov. 5, 1960, as amended by CGFR 64-19, 29 FR 7360, June 5, 1964]

#### § 162.028-5 Independent laboratories: Listing.

The following have met the standards under §159.101-7 for listing as an independent laboratory to perform or supervise approval or production inspections or tests of portable fire extinguishers:

(a) For dry chemical, CO<sub>2</sub>, water and foam type portable fire extinguishers:

(1) Underwriters Laboratories, Inc., mailing address: P.O. Box 247, Northbrook, Illinois 60062.

(2) Underwriters' Laboratories of Canada, mailing address: 7 Crouse Rd, Scarborough, Ontario, MIR 3A9, Canada.

(b) For halon type fire extinguishers:

(1) Underwriters Laboratories, Inc., mailing address: P.O. Box 247, Northbrook, Illinois 60062.

(2) Underwriters' Laboratories of Canada, mailing address: 7 Crouse Rd,

#### 46 CFR Ch. I (10-1-11 Edition)

Scarborough, Ontario, MIR 3A9, Canada.

(3) Factory Mutual Research Corporation, mailing address: 1151 Boston-Providence Turnpike, P.O. Box 688, Norwood, MA 02062.

[CGD 83-050, 49 FR 7566, Mar. 1, 1984]

#### § 162.028-6 Examinations, tests, and inspections.

(a) Full examinations, tests, and inspections to determine the suitability of a product for listing and labeling, and to determine conformance of labeled product to the applicable requirements are conducted by the recognized laboratory. Whenever any work is being done on components or the assembly of such product, the manufacturer shall notify the recognized laboratory in order that an inspector may be assigned to the factory to conduct such examinations, inspections, and tests as to satisfy himself that the quality assurance program of the manufacturer is satisfactory, and that the labeled product is in conformance with the applicable requirements.

(b) Manufacturers of listed or labeled marine type portable fire extinguishers shall maintain quality control of the materials used, manufacturing methods, and the finished product so as to meet the applicable requirements, and shall make sufficient inspections and tests of representative samples of the extinguishers and various components produced to maintain the quality of the finished product. Records of tests conducted by the manufacturer shall be made available to the laboratory inspector or to the merchant marine inspector, or both, for review upon request.

(c) Follow-up check tests, examinations, and inspections of product listed and labeled as a "marine type" portable fire extinguisher acceptable to the Commandant as approved for use on merchant vessels and motorboats may be conducted by the Coast Guard, as well as by the recognized laboratory.

(d) The laboratory inspector, or the Coast Guard marine inspector assigned by the Commander of the District in which the factory is located, or both, shall be admitted to any place in the factory where work is being done on listed or labeled product, and either or

## Coast Guard, DHS

## § 162.039-3

both inspectors may take samples of parts or materials entering into construction, or final assemblies, for further examinations, inspections or tests. The manufacturer shall provide a suitable place and the apparatus necessary for the performance of the tests which are done at the place of manufacture.

### § 162.028-7 Procedure for listing and labeling.

(a) Manufacturers having a marine-type portable fire extinguisher which they consider has characteristics suitable for general use on merchant vessels and motorboats may make application for listing and labeling as a marine-type portable fire extinguisher by addressing a request directly to a recognized laboratory. The laboratory will inform the submitter as to the requirements for inspection, examinations, and testing necessary for such listing and labeling. The request shall include permission for the laboratory to furnish a complete test report together with a description of the quality control procedures to the Commandant.

(b) The U.S. Coast Guard will review the test report and quality control procedures to determine if the requirements in § 162.028-3 have been met. If this is the case, the Commandant will notify the laboratory that the extinguisher is approved and that when the extinguisher is listed and labeled, it may be marked as being U.S. Coast Guard approved.

(c) If disagreements concerning procedural, technical, or inspection questions arise over U.S. Coast Guard approval requirements between the manufacturer and the laboratory, the opinion of the Commandant shall be requested by the laboratory.

(d) The manufacturer or the laboratory may at any time request clarification or advice from the Commandant on any question which may arise regarding manufacturing and approval of approved devices.

[CGD 72-214R, 38 FR 6880, Mar. 14, 1973]

### § 162.028-8 Termination of listing or labeling.

(a) Listing or labeling as a marine type portable fire extinguisher acceptable to the Commandant as approved

for use on inspected vessels and motorboats, may be terminated, withdrawn, cancelled, or suspended by written notice to the recognized laboratory from the Commandant, or by written notice to the manufacturer from the recognized laboratory or from the Commandant, under the following conditions:

(1) When the manufacturer does not desire to retain the service.

(2) When the listed product is no longer being manufactured.

(3) When the manufacturer's own program does not provide suitable assurance of the quality of the listed or labeled product being manufactured.

(4) When the product manufactured no longer conforms to the current applicable requirements.

(5) When service experience or laboratory or U.S. Coast Guard reports indicate a product is unsatisfactory.

(b) [Reserved]

[CGFR 60-36, 25 FR 10640, Nov. 5, 1960, as amended by CGD 72-214R, 38 FR 6880, Mar. 14, 1973]

## Subpart 162.039—Extinguishers, Fire, Semiportable, Marine Type

SOURCE: CGFR 65-9, 30 FR 11487, Sept. 8, 1965, unless otherwise noted.

### § 162.039-1 Applicable specifications.

(a) There are no other Coast Guard specifications applicable to this subpart.

(b) [Reserved]

### § 162.039-2 Classification.

(a) Every semiportable fire extinguisher shall be classified as to type and size as specified in § 76.50-5 (Subchapter H—Passenger Vessels) of this chapter.

(b) [Reserved]

### § 162.039-3 Requirements.

(a) *General.* Every semiportable fire extinguisher shall conform to the requirements for listing and labeling by a recognized laboratory and shall be of such design, materials, and construction as to meet the requirements specified in this section.

(b) *Design.* Every semiportable extinguisher shall be fitted with hose of sufficient length to a nozzle or nozzles to provide for suitable application of the extinguishing agent to any part of the space protected (a length of pipe may connect the outlet of the supply to the hose connection); shall weigh more than 55 pounds when fully charged; shall be self-contained, i.e., when charged, it shall not require any additional source of extinguishing agent or expellant energy for its operation; and shall provide simple means for immediate operation by a single operator. The design, materials and construction shall provide reliability of operation and performance after non-use for long periods under conditions encountered in marine service.

(c) *Materials.* Materials used for exposed working parts, except those used for inversion mechanism or similar purposes, shall be corrosion-resistant to salt water and spray. Materials used for other exposed parts shall be either corrosion-resistant or shall be protected by a suitable corrosion-resistant coating.

(1) *Corrosion-resistant materials.* The materials which are considered to be corrosion-resistant are copper, brass, bronze, certain copper-nickel alloys, certain alloys of aluminum, certain plastics, and certain stainless steels.

(2) *Corrosion-resistant coatings.* (i) The following systems of organic or metallic coatings for exposed nonworking ferrous parts except for ICC cylinders, when applied on properly prepared surfaces after all cutting, forming, and bending operations are completed, are considered to provide suitable corrosion resistance:

(a) Bonderizing, followed by the application of zinc chromate primer, followed by one or more applications of enamel; or,

(b) Inorganic zinc coatings; or,

(c) Hot-dipped or electrodeposited zinc in thicknesses not less than 0.002 inch; or,

(d) Electrodeposited Cadmium in thicknesses not less than 0.001 inch; or,

(e) Hot-dipped or sprayed aluminum in thicknesses not less than 0.002 inch; or,

(f) Copper plus nickel in total thicknesses not less than 0.003 inch, or

which the nickel is not less than 0.002 inch, plus any thickness of chrome.

(ii) The metallic platings of less than the thicknesses specified in this paragraph are not acceptable for the protection against corrosion of ferrous parts.

(3) *Decorative platings.* Decorative platings in any thicknesses applied over corrosion-resistant materials and corrosion-resistant coatings are acceptable for either working or non-working parts.

(4) *Dissimilar metals.* The use of dissimilar metals in combination shall be avoided wherever possible, but when such contacts are necessary, provisions (such as bushings, gaskets, or o-rings) shall be employed to prevent such deleterious effects as galvanic corrosion, freezing or buckling of parts, and loosening or tightening of joints due to differences in thermal expansion.

(5) *Suitability of materials.* In event of question as to the suitability of the materials (including coatings) used, the salt spray test described in paragraph (c)(6) of this section shall be conducted.

(6) *Salt spray test.* Expose either component parts, subassemblies, or the complete fully charged specimen extinguisher to a 20 percent sodium-chloride solution spray at a temperature of 95 °F. (35 °C.) for a period of 240 hours. The procedures and apparatus described in Method 811 of Federal Test Method Standard No. 151 are suitable. Alternate methods may be found satisfactory if the results are comparable. Following the test, allow the specimen extinguisher to air dry for a period of 48 hours. Following the air drying, the specimen extinguisher shall be capable of being operated satisfactorily without undue effort or special procedures on the part of the operator, and it shall be capable of being recharged satisfactorily in accordance with the directions on the nameplate without the use of extraordinary tools or procedures.

(d) *Gauges.* Every pressure gauge used on a semiportable fire extinguisher shall have an accuracy of at least 2 percent of the scale range for the middle half of the scale conforming to ASME Grade B commercial accuracy. The gauge when new shall be watertight, i.e., with the connection capped or

plugged, no water shall penetrate to the interior of the case during submergence 1 foot below the surface of water for a period of 2 hours. The gauge shall be constructed of corrosion-resistant materials, so that the pointer or face lettering will not be obliterated by the action of salt water if some leakage should occur after rough handling or extended periods of service. The gage, when attached to the extinguisher, shall pass the salt spray and vibration tests prescribed by paragraphs (c)(6) and (e) of this section.

(e) *Vibration resistance.* Either component parts, subassemblies, or the complete, fully charged specimen extinguisher, shall be tested in accordance with sections 3.1 through 3.1.4.4 of Military Standard MIL-STD-167. Following this test, there shall be no obvious failures of parts or assemblies, and they shall be capable of being operated satisfactorily without undue effort or special procedures on the part of the operator, and the extinguisher shall be capable of being recharged satisfactorily in accordance with the directions on the name plate without the use of extraordinary tools or procedures.

(f) *Carbon dioxide type.* Every carbon dioxide type extinguisher shall be fitted with a valve which will withstand a minimum bursting pressure of 6,000 p.s.i., and a discharge hose or tube which will withstand a minimum bursting pressure of 5,000 p.s.i. The hose shall be constructed with either a wire braid or other conducting material for conducting static charges occurring at the discharge nozzle back to the body of the extinguisher.

(g) *Chemical-foam type.* Every chemical foam type semiportable fire extinguisher shall have a nozzle which will provide operating characteristics such that when it is held about 3 feet above the ground at an elevation of approximately 30°, and with the extinguisher and contents both at approximately 70 °F. and 120 °F., the range of the stream shall not exceed 40 feet, and the major portion of the discharge shall fall between 20 and 40 feet, measured horizontally, from the nozzle. The duration of the effective discharge shall be between 2.5 and 4.0 minutes, effective discharge being considered as occurring while the major portion of the dis-

charge falls beyond 10 feet, measured horizontally, from the nozzle.

(h) [Reserved]

(i) *Toxic extinguishing agents.* Every semiportable fire extinguisher shall contain only agents which qualify for the Underwriters' Laboratories, Inc., toxicity rating of Group 5 or Group 6, and which in normal fire extinguishing use do not generate decomposition products in concentrations hazardous to life. Acceptance of extinguishing agents under these requirements will be determined by the Coast Guard.

(j) *Fire tests.* Fire tests may be employed in determining the suitability for "marine type" listing and labeling.

(k) *Additional tests.* Every semiportable extinguisher may be additionally examined and tested to establish its reliability and effectiveness in accordance with the intent of this specification for a "marine type" semiportable fire extinguisher when considered necessary by the Coast Guard or by the recognized laboratory.

(1) *Additional marking.* (1) As part of the usual nameplate marking, there shall be included the rated capacity of the extinguisher in gallons, quarts, or pounds, and complete instructions for recharging, including the identification of the recharge materials and of the pressure containing cylinder or separate container if one is used.

(2) Pasted-on type paper or decalcomania labels are not acceptable for any of the required extinguisher marking.

(3) Recharge packages shall be legibly marked with the name of the recharge and the capacity of contents in gallons, quarts, or pounds in addition to the usual recharge package marking. Recharge pressure containing cylinders shall, in addition to the usual marking, also be plainly marked to show the distinctive identifying designation of the cylinder.

(m) *Securing means.* Every semiportable fire extinguisher shall be supplied with a suitable means for holding the extinguisher securely in its stowage location on vessels or boats. The materials shall be sufficiently corrosion-resistant or protected against corrosion to withstand the test prescribed by paragraph (c)(6) of this section without

**§ 162.039-4**

**46 CFR Ch. I (10-1-11 Edition)**

showing more than traces of slight corrosion, which may be easily wiped off after rinsing with tapwater.

[CGFR 65-9, 30 FR 11487, Sept. 8, 1965, as amended by CGFR 65-64, 31 FR 563, Jan. 18, 1966; CGD 73-73R, 38 FR 27354, Oct. 3, 1973; CGD 77-039, 44 FR 34133, June 14, 1979]

**§ 162.039-4 Marine type label.**

(a) In addition to all other marking, every semiportable extinguisher shall bear a label containing the "marine type" listing manifest issued by a recognized laboratory. This label will include the classification of the extinguisher in accordance with the Coast Guard classification system, and the Coast Guard approval number, thus: "Marine Type USCG Type \_\_\_\_, Size \_\_\_\_, Approval No. 162.039/Ex \_\_\_\_." All such labels are to be obtained from the recognized laboratory and will remain under its control until attached to product found acceptable under its listing and labeling program.

(b) [Reserved]

**§ 162.039-5 Recognized laboratory.**

(a) A recognized laboratory is one which is regularly engaged in the examination, testing, and evaluation of semi-portable fire extinguishers; which has an established factory inspection, listing, and labeling program; and which has special standards for listing and labeling as a "marine type" semiportable fire extinguisher acceptable to the Commandant as approved for use on merchant vessels and motorboats. The following laboratories are recognized, and the semiportable fire extinguishers bearing their "marine type" labels are approved for use on merchant vessels and motorboats:

(1) Underwriters' Laboratories, Inc., mailing address: Post Office Box 247, Northbrook, Ill., 60062.

(2) [Reserved]

(b) [Reserved]

**§ 162.039-6 Examinations, tests, and inspections.**

(a) Full examinations, tests, and inspections to determine the suitability of a product for listing and labeling, and to determine conformance of labeled product to the applicable requirements are conducted by the recognized laboratory. Whenever any work is

being done on components or the assembly of such product, the manufacturer shall notify the recognized laboratory in order that an inspector may be assigned to the factory to conduct such examinations, inspections, and tests as to satisfy himself that the quality assurance program of the manufacturer is satisfactory, and that the labeled product is in conformance with the applicable requirements.

(b) Manufacturers of listed or labeled marine type semiportable fire extinguishers shall maintain quality control of the materials used, manufacturing methods, and the finished product so as to meet the applicable requirements, and shall make sufficient inspections and tests of representative samples of the extinguishers and various components produced to maintain the quality of the finished product. Records of tests conducted by the manufacturer shall be made available to the laboratory inspector or to the Coast Guard marine inspector, or both, for review upon request.

(c) Followup check tests, examinations, and inspections of product listed and labeled as a "marine type" semiportable fire extinguisher acceptable to the Commandant as approved for use on merchant vessels and motorboats may be conducted by the Coast Guard, as well as by the recognized laboratory.

(d) The laboratory inspector, or the Coast Guard merchant marine inspector assigned by the Commander of the District in which the factory is located, or both, shall be admitted to any place in the factory where work is being done on listed or labeled product, and either or both inspectors may take samples of parts or materials entering into construction, of final assemblies, for further examinations, inspections, or tests. The manufacturer shall provide a suitable place and the apparatus necessary for the performance of the tests which are done at the place of manufacture.

**§ 162.039-7 Procedure for listing and labeling.**

(a) Manufacturers having models of extinguishers which they believe are suitable for marine service may make application for listing and labeling of

such product as a “marine type” semiportable fire extinguisher which will be acceptable to the Commandant as approved for use on merchant vessels, by addressing a request directly to a recognized laboratory. The laboratory will inform the submitter as to the requirements for inspections, examinations, and testing necessary for such listing and labeling. All costs in connection with the examinations, tests, and inspections, listings and labelings are payable by the manufacturer.

(b) [Reserved]

**§ 162.039-8 Termination of listing or labeling.**

(a) Listing or labeling as a marine type semiportable fire extinguisher acceptable to the Commandant as approved for use on inspected vessels or motorboats may be terminated, withdrawn, canceled, or suspended by written notice to the recognized laboratory from the Commandant, or by written notice to the manufacturer from the recognized laboratory or from the Commandant under the following conditions:

- (1) When the manufacturer does not desire to retain the service.
- (2) When the listed product is no longer being manufactured.
- (3) When the manufacturer’s own program does not provide suitable assurance of the quality of the listed or labeled product being manufactured.
- (4) When the product manufactured no longer conforms to the current applicable requirements.

(b) [Reserved]

**Subpart 162.050—Pollution Prevention Equipment**

SOURCE: CGD 76-088a, 44 FR 53359, Sept. 13, 1979, unless otherwise noted.

**§ 162.050-1 Scope.**

(a) This subpart contains—

- (1) Procedures for approval of 15 ppm separators, oil content meters, and bilge alarms.
- (2) Design specifications for this equipment;
- (3) Tests required for approval;

(4) Procedures for obtaining designation as a facility authorized to conduct approval tests;

(5) Marking requirements; and

(6) Factory inspection procedures.

(b) [Reserved]

[CGD 76-088a, 44 FR 53359, Sept. 13, 1979, as amended by USCG-2004-18939, 74 FR 3382, Jan. 16, 2009]

**§ 162.050-3 Definitions.**

As used in this subpart—

*15 ppm separator* means a separator that is designed to remove enough oil from an oil-water mixture to provide a resulting mixture that has an oil concentration of 15 ppm or less.

*Bilge alarm* means an instrument that is designed to measure the oil content of oily mixtures from machinery space bilges and fuel oil tanks that carry ballast and activate an alarm at a set concentration limit and record date, time, alarm status, and operating status of the 15 ppm separator.

*Independent laboratory* means a laboratory that—

(1) Has the equipment and procedures necessary to approve the electrical components described in §§ 162.050-21(b) and 162.050-25(c), or to conduct the test described in § 162.050-37(a); and

(2) Is not owned or controlled by a manufacturer, supplier, or vendor of separators, oil content meters, or bilge alarms.

*Oil content meter* or *meter* means a component of the oil discharge monitoring and control system that is designed to measure the oil content of cargo residues from cargo tanks and oily mixtures combined with these residues.

*PPM* means parts per million by volume of oil in water.

*Response time* means the time elapsed between an alteration in the sample being supplied to the bilge alarm and the ppm display showing the correct response.

[USCG-2004-18939, 74 FR 3382, Jan. 16, 2009]

**§ 162.050-4 Incorporation by reference: Where can I get a copy of the publications mentioned in this part?**

(a) Certain material is incorporated by reference into this subpart with the approval of the Director of the Federal Register under 5 U.S.C. 552(a) and 1

§ 162.050-5

46 CFR Ch. I (10-1-11 Edition)

CFR part 51. To enforce any edition other than that specified in paragraph (b) of this section, the Coast Guard must publish a notice of change in the FEDERAL REGISTER and the material must be available to the public. All approved material is available for inspection at the National Archives and Records Administration (NARA). For information on the availability of this material at NARA, call 202-741-6030 or go to [http://www.archives.gov/federal-register/code\\_of\\_federal\\_regulations/ibr\\_locations.html](http://www.archives.gov/federal-register/code_of_federal_regulations/ibr_locations.html). Also, it is available for inspection at the Coast Guard, Office of Design and Engineering Standards (CG-521), 2100 2nd St., SW., Stop 7126, Washington, DC 20593-7126, telephone 202-372-1379, and is available from the sources indicated in paragraph (b) of this section.

(b) *American Society for Testing and Materials* 100 Barr Harbor Drive, West Conshohocken, PA 19428-2959.

(1) ASTM D2777-98, Standard Practice for Determination of Precision and Bias of Applicable Test Methods of Committee D-19 on Water (“ASTM D2777-98”), incorporation by reference approved for §162.050-15.

(2) [Reserved]

(c) *International Organization for Standardization (ISO)* 1, rue de Varembé, Case postale 56, CH-1211 Geneva 20, Switzerland (Internet: <http://www.iso.org>):

(1) International Standard ISO 8217 Third edition 2005-11-01, Petroleum products—Fuels (class F)—Specifications of marine fuels (“ISO 8217”), incorporation by reference approved for §162.050-20.

(2) International Standard ISO 9377-2 First edition 2000-10-15, Water Quality—Determination of hydrocarbon oil index—Part 2: Method using solvent extraction and gas chromatography (“ISO 9377-2”), incorporation by reference approved for §162.050-39.

(d) *Underwriters Laboratories, Inc., (UL)* 12 Laboratory Drive, Research Triangle Park, NC 27709-3995

(1) Underwriters Laboratories Standard 913 (as revised April 8, 1976), incorporation by reference approved for §§162.050-21, 162.050-25.

(2) [Reserved]

[USCG-2004-18939, 74 FR 3383, Jan. 16, 2009, as amended by USCG-2009-0702, 74 FR 49238, Sept. 25, 2009]

§ 162.050-5 Contents of application.

(a) An application for approval of a separator, oil content meter, or a bilge alarm must contain the following information:

(1) A brief description of the item submitted for approval.

(2) The name and address of the applicant and its manufacturing facility.

(3) A detailed description of quality control procedures, in-process and final inspections and tests followed in manufacturing the item, and construction and sales record keeping systems maintained.

(4) Arrangement drawings and piping diagrams of the item that give the information prescribed by §56.01-10(d) of this chapter.

(5) Detailed electrical plans of the type described in §110.25-1 of this chapter.

(6) An operating and maintenance manual containing detailed and easily understandable instructions on installation, operation, calibration, zeroing, and maintenance of the item.

(7) For each monitor and bilge alarm and each control on a separator, the vibration test report described in §162.050-37.

(8) For each oil content meter, a statement of whether it is to be used with crude oils, refined products, or both.

(9) A list of the substances used in operating the item that require certification under part 147 of this chapter as articles of ships’ stores and supplies.

(10) The name of the facility to conduct approval testing.

(11) If the applicant intends to use a test rig other than a test rig of the facility, a detailed description of the rig.

(b) An applicant may incorporate by reference in his application information that he has submitted in a previous application.

[44 FR 53359, Sept. 13, 1979, as amended by USCG-1999-6216, 64 FR 53228, Oct. 1, 1999; USCG-2004-18939, 74 FR 3383, Jan. 16, 2009]



**§ 162.050-7 Approval procedures.**

(a) An application for approval of equipment under this subpart must either be delivered by visitors to the Commanding Officer, U.S. Coast Guard Marine Safety Center, Engineering Division, 1900 Half Street, SW., Suite 1000, Room 525, Washington, DC 20024, or transmitted by mail to Commanding Officer, U.S. Coast Guard Marine Safety Center, 2100 2nd St., SW., Stop 7126, Washington, DC 20593-7126, in a written or electronic format. Information for submitting the VSP electronically can be found at <http://www.uscg.mil/HQ/MSC>.

(b) The application is examined by the Coast Guard to determine whether the item complies with the design requirements and vibration standard prescribed in this subpart and to determine what probability the item has of passing the approval tests. The applicant is notified of the results of the examination.

(c) If examination of the application reveals that it is incomplete, it is returned to the applicant with a statement of reasons why it is incomplete.

(d) The applicant must make arrangements for approval testing directly with a testing facility and must provide the facility with a copy of the instructions manual for the equipment to be tested.

(e) If applications for approval of a separator have been made for more than one size, the applicant, in lieu of submitting each size for approval testing, may submit each size that has a capacity exceeding 50 cubic meters per hour throughput, if any, and two additional sizes that have a capacity of 50 cubic meters per hour throughput or less. One of the additional sizes must have a capacity that is in the highest quartile of capacities manufactured in the 0-50 cubic meters per hour throughput range and the other must be from the lowest quartile.

(f) The approval tests in this subpart must be performed by a facility designated under §162.050-15. The facility must also be accepted as an independent laboratory by the Coast Guard under subpart 159.010 of this chapter. The facility must perform each test in accordance with the test conditions prescribed in this subpart for the test, prepare a test report for the item if it

completes all of the tests, and send the report with three copies to the Commanding Officer, USCG Marine Safety Center. The applicant may observe the tests. If an item does not complete testing, a new application must be made before retesting.

(g) The Commanding Officer, USCG Marine Safety Center, sends a copy of the test report to the applicant and advises him whether the item is approved. If the item is approved, an approval certificate is sent to the applicant. The approval certificate lists conditions of approval applicable to the item.

(h) A separator is approved under this subpart if—

(1) It meets the design requirements in §162.050-21 and is tested in accordance with this subpart;

(2) The oil content of each sample of separated water effluent taken during approval testing is 15 ppm or less;

(3) During Test No. 3A an oily mixture is not observed at the separated water outlet of the separator;

(4) During Test No. 5A its operation is continuous; and

(5) Any substance used in operating the separator that requires certification under part 147 of this chapter as an article of ships' stores or supplies has been certified.

(i) An oil content meter is approved under this subpart if—

(1) It meets the design requirements in §162.050-25 and is tested in accordance with this subpart;

(2) Each oil content reading recorded during approval testing is  $\pm 10$  ppm or  $\pm 10$  percent, whichever is greater, of the oil content of the sample influent mixture taken at the time of the reading;

(3) Its response time is twenty (20) seconds or less in Test No. 3CM;

(4) The time intervals between successive readings recorded in Test No. 4CM are twenty (20) seconds or less; and

(5) Any substance used in operating the monitor that requires certification under part 147 of this chapter as an article of ships' stores or supplies has been certified.

(j) A bilge alarm is approved under this subpart if—

**§ 162.050-9**

**46 CFR Ch. I (10-1-11 Edition)**

(1) It meets the design requirements in §162.050-33 and is tested in accordance with this subpart;

(2) The oil content of each sample taken during approval testing is 15 ppm ± 5 ppm;

(3) Its response time is five seconds or less; and

(4) Any substance used in operating the alarm that requires certification under part 147 of this chapter as an article of ships' stores or supplies has been certified.

[44 FR 53359, Sept. 13, 1979, as amended by CGD 82-063b, 48 FR 4783, Feb. 3, 1983; 48 FR 45114, Oct. 3, 1983; CGD 88-070, 53 FR 34537, Sept. 7, 1988; CGD 95-072, 60 FR 50467, Sept. 29, 1995; CGD 96-041, 61 FR 50734, Sept. 27, 1996; USCG-1999-6216, 64 FR 53228, Oct. 1, 1999; USCG 2001-10224, 66 FR 48621, Sept. 21, 2001; USCG-2007-29018, 72 FR 53967, Sept. 21, 2007; USCG-2004-18939, 74 FR 3383, Jan. 16, 2009; USCG-2009-0702, 74 FR 49238, Sept. 25, 2009]

**§ 162.050-9 Test report.**

(a) A report of approval testing must contain the following:

(1) Name of the testing facility.

(2) Name of the applicant.

(3) Date of receiving the item for testing and the dates of the tests conducted.

(4) Trade name and brief description of the item.

(5) A listing of the following properties of the test oils used:

(i) Relative density at 15 °C.

(ii) Viscosity in centistokes at 37.8 °C.

(iii) Flashpoint.

(iv) Weight of ash content.

(v) Weight of water content.

(vi) Relative density at 15 °C. the of water used during testing and the weight of solid content in the water.

(vii) The data recorded during each test.

(6) A statement that the lab followed the testing procedures prescribed in 46 CFR subpart 162.050.

(b) [Reserved]

[CGD 76-088a, 44 FR 53359, Sept. 13, 1979, as amended by USCG-2004-18939, 74 FR 3383, Jan. 16, 2009]

**§ 162.050-11 Marking.**

(a) Each separator, oil content meter, and bilge alarm manufactured under Coast Guard approval must be plainly marked by the manufacturer with the

information listed in paragraph (b) of this section. The marking must be securely fastened to the item.

(b) Each marking must include the following information:

(1) Name of the manufacturer.

(2) Name or model number of the item.

(3) If the item is a separator, the maximum throughput and the maximum influent pressure at which the separator is designed to operate.

(4) The month and year of completion of manufacture.

(5) The manufacturer's serial number for the item.

(6) The Coast Guard approval number assigned to the item in the certificate of approval.

(7) A list of bilge cleaners, solvents, and other chemical compounds that do not impair operation of the item.

(8) If the item is an oil content meter, the oils for which use has been approved.

(9) If the item is a separator that uses replaceable filter or coalescer elements, the part numbers of the elements.

[CGD 76-088a, 44 FR 53359, Sept. 13, 1979, as amended by USCG-2004-18939, 74 FR 3383, Jan. 16, 2009]

**§ 162.050-13 Factory production and inspection.**

(a) Equipment manufactured under Coast Guard approval must be of the type described in the current certificate of approval issued for the equipment.

(b) Equipment manufactured under Coast Guard approval is not inspected on a regular schedule at the place of manufacture. However, the Commanding Officer, USCG Marine Safety Center, may detail Coast Guard personnel at any time to visit a factory where the equipment is manufactured to conduct an inspection of the manufacturing process.

[44 FR 53359, Sept.13, 1979, as amended by USCG 2001-10224, 66 FR 48621, Sept. 21, 2001]

**§ 162.050-15 Designation of facilities.**

(a) Each request for designation as a facility authorized to perform approval

tests must be submitted to the Commandant (CG-5213), Systems Engineering Division, 2100 2nd St., SW., Stop 7126, Washington, DC 20593-7126.

(b) Each request must include the following:

(1) Name and address of the facility.

(2) Each type of equipment the facility proposes to test.

(3) A description of the facility's capability to perform approval tests including detailed information on the following:

(i) Management organization including personnel qualifications.

(ii) Equipment available for conducting sample analysis.

(iii) Materials available for approval testing.

(iv) Each of the facility's test rigs, if any.

(c) The Coast Guard reviews each request submitted to determine whether the facility meets the requirements of paragraphs (g)(1) through (g)(4) of this section.

(d) If the facility meets the requirements in paragraphs (g)(1) through (g)(4) of this section, they must obtain 12 samples containing mixtures of oil in water that are within a 10-to-30 ppm range that can be verified by an independent third-party source mutually acceptable to the applying lab and the Coast Guard prior to verification.

(e) The facility must measure the oil content of each sample using the method described in §162.050-39 and report the value of each of the 12 measurements to the Commandant (CG-5213), Systems Engineering Division, 2100 2nd St., SW., Stop 7126, Washington, DC 20593-7126.

(f) The measurements must meet the following criteria:

(1) Except as provided in paragraph (f)(2) of this section, the absolute value of  $T_n$  for each measurement, as determined by the American Society for Testing and Materials, "Standard Practice for Determination of Precision and Bias of Methods of Committee D-19 on Water", D 2777 (incorporated by reference, see §162.050-4), must be less than or equal to 2.29 at a confidence level of 0.05.

(2) The absolute value of  $T_n$  for one measurement may exceed 2.29 if the  $T_n$  values for the other eleven measure-

ments are less than or equal to 2.23 at a confidence level of 0.05. If the  $T_n$  value for one measurement exceeds 2.29, that measurement is not used in the method described in paragraph (f)(3) of this section.

(3) The absolute value of  $X_d$  must be smaller than  $u$  based on the following analysis of paired observations:

(i) Calculate the value of  $\bar{X}_d$  and  $S_d$ . This is the mean and standard deviation, respectively, of the differences between the known sample concentrations and the values obtained by the facility with their equipment. The value of  $\bar{X}_d$  for the 12 measurements described in paragraph (e) of this section, or for 11 measurements if paragraph (f)(2) of this section applies, must be within the range  $1 \leq \bar{X}_d \leq +1$ .

(ii) Determine the appropriate critical value of the Student's  $t$ -distribution with  $(n-1)$  degrees of freedom for a confidence level of  $\alpha = 0.01$ . If all 12 samples meet the criteria of paragraph (f)(1) of this section then  $(n-1) = 11$  and the critical value,

$$t_{1-\frac{\alpha}{2}}$$

is 3.106. If paragraph (f)(2) of this section applies, then  $(n-1) = 10$  and

$$t_{1-\frac{\alpha}{2}} = 3.169.$$

=3.169.

(iii) Compute the value of  $u$ , where

$$u = t_{1-\frac{\alpha}{2}} \left( \frac{S_d}{\sqrt{n}} \right),$$

where  $n = 12$  if all samples meet the criteria of paragraph (f)(1) and  $n = 11$  if paragraph (f)(2) applies.

(iv) Compare the absolute value of  $\bar{X}_d$  to the value of  $u$ . If  $|\bar{X}_d| < u$ , then the facility meets the criteria.

(g) To obtain authorization to conduct approval tests—

(1) A facility must have the management organization, equipment for conducting sample analysis, and the materials necessary to perform the tests;

(2) Each facility test rig must be of a type described in §162.050-17 or §162.050-19;

§ 162.050-17

46 CFR Ch. I (10-1-11 Edition)

(3) The loss or award of a specific contract to test equipment must not be a substantial factor in the facility's financial well being;

(4) The facility must be free of influence and control of the manufacturers, suppliers, and vendors of the equipment; and

(5) The oil content measurements submitted to the Commandant must meet the criteria in paragraph (f) of this section.

(h) A facility may not subcontract for approval testing unless previously authorized by the Coast Guard. A request for authorization to subcontract must be sent to the Commandant (CG-5213), Systems Engineering Division,

2100 2nd St., SW., Stop 7126, Washington, DC 20593-7126.

[44 FR 53359, Sept. 13, 1979, as amended by CGD 82-063b, 48 FR 45114, Oct. 3, 1983; CGD 88-070, 53 FR 34537, Sept. 7, 1988; CGD 95-072, 60 FR 50467, Sept. 29, 1995; CGD 96-041, 61 FR 50734, Sept. 27, 1996; USCG-1999-5151, 64 FR 67185, Dec. 1, 1999; USCG 2001-10224, 66 FR 48621, Sept. 21, 2001; USCG-2007-29018, 72 FR 53968, Sept. 21, 2007; USCG-2004-18939, 74 FR 3383, Jan. 16, 2009; 74 FR 6358, Feb. 9, 2009; USCG-2009-0702, 74 FR 49238, Sept. 25, 2009]

§ 162.050-17 Separator test rig.

(a) This section contains requirements for test rigs used in approval testing of separators. A diagram of a typical test rig is shown in Figure 162.050-17(a).

FIGURE 162.050-17(a)—SEPARATOR TEST RIG

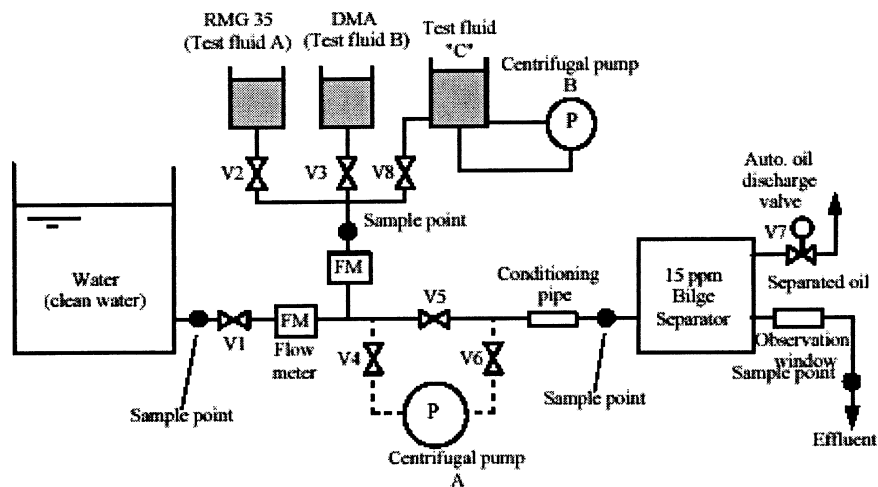

(b) Each mixture pump on a test rig must—

(1) Be a centrifugal pump capable of operating at 1,000 revolutions per minute or more;

(2) Have a delivery capacity of at least 1.5 times the maximum throughput at which the separator being tested is designed to operate;

(3) Have a maximum delivery pressure that is equal to or greater than the maximum influent pressure at

which the separator is designed to operate; and

(4) Have either bypass piping to its suction side or a throttle valve or orifice on its discharge side.

(c) The inlet piping of the test rig must be sized so that—

(1) Influent water flows at a Reynolds Number of at least 10,000;

(2) The influent flow rate is between one and three meters per second; and

(3) Its length is at least 20 times its inside diameter.

(d) Each sample point on a test rig must meet the design requirements described in Figure 162.050-17(d) and must

be in a vertical portion of the test rig piping.

FIGURE 162.050-17(d)—SAMPLE POINT

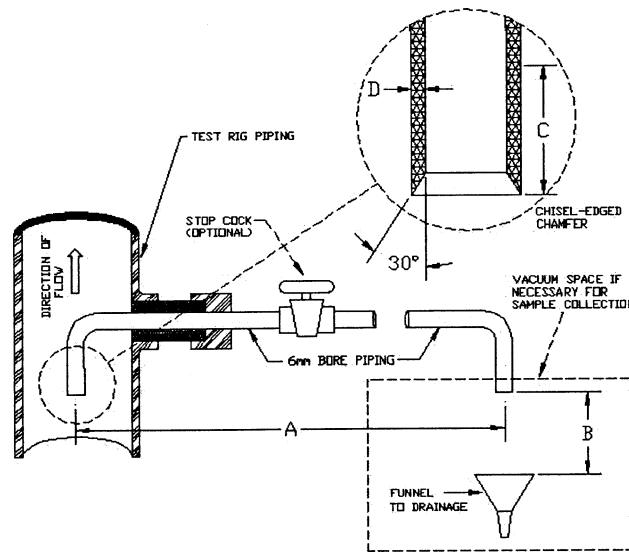

- A DIMENSION A IS NOT GREATER THAN 400 MM
- B HEIGHT B IS LARGE ENOUGH TO INSERT A SAMPLE BOTTLE
- C DISTANCE C IS A STRAIGHT LINE OF NOT LESS THAN 60 MM
- D WIDTH D IS NOT GREATER THAN 2 MM

[CGD 76-088a, 44 FR 53359, Sept. 13, 1979, as amended by USCG-2004-18939, 74 FR 3384, Jan. 16, 2009]

**§ 162.050-19 Oil content meter and bilge alarm test rig.**

(a) This section contains requirements for test rigs used in approval testing of oil content meters and meter. A typical test rig is described in Figure 162.050-19. The mixture pipe shown in Figure 162.050-19 is the portion of test rig piping between the oil injection point and the meter or bilge alarm point.

(b) Each sample point on a test rig must be of the type described in Figure 162.050-17(e) and must be in a vertical portion of the test rig piping.

(c) Each test rig must have a centrifugal pump that is designed to operate at 1,000 revolutions per minute or more.

(d) The mixture pipe on a test rig must have a uniform inside diameter.

FIGURE 162.050-19—MONITOR AND BILGE ALARM TEST RIG

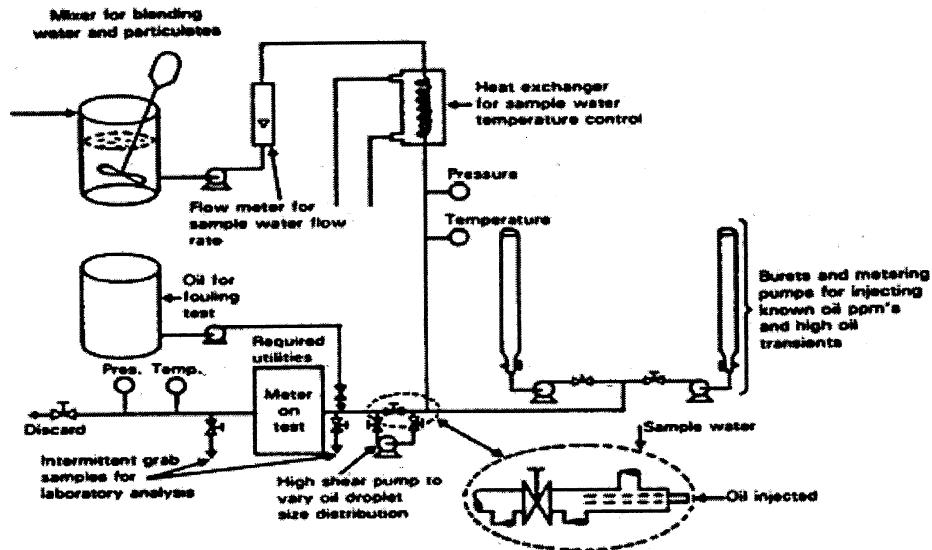

[CGD 76-088a, 44 FR 53359, Sept. 13, 1979, as amended by USCG-2004-18939, 74 FR 3385, Jan. 16, 2009]

**§ 162.050-20 Separator and bilge alarm test fluids.**

(a) Tests required in §§162.050-23 and 162.050-35 must be performed using the following three types of test fluids:

- (1) Test Fluid A, which is a marine residual fuel oil in accordance with ISO 8217 (incorporated by reference, see §162.050-4), type RMG 380 (density at 15 °C not less than 980 kg/m<sup>3</sup>);
- (2) Test Fluid B which is a marine distillate fuel oil in accordance with ISO 8217, type DMA (density at 15 °C not less than 830 kg/m<sup>3</sup>);
- (3) Test Fluid C must be a mixture of an oil-in-fresh water emulsion, where 1 kg of the mixture consists of:
  - (i) 947.8 g of fresh water;
  - (ii) 25.0 g of Test Fluid A;
  - (iii) 25.0 g of Test Fluid B;
  - (iv) 0.5 g of surfactant (sodium salt of dodecylbenzene sulfonic acid) in the dry form; and
  - (v) 1.7 g of iron oxides, a black ferrosiferrous oxide (Fe<sub>3</sub>O<sub>4</sub>) with a particle size distribution of which 90 percent is less than 10 microns, the remainder having a maximum particle size of 100 microns.

(b) Test Fluid C must be prepared as needed for §162.050-23 or §162.050-35 by using the following procedures:

- (1) Measure out 1.2 times the quantity of surfactant required from the WORKSHEET FOR DETERMINING CONSTITUENTS OF TEST FLUID C, see figure 162.050-20;
- (2) Mix it with fresh water and stir well in a small container to make a mixture until the surfactant has been thoroughly dissolved, but use no more than the minimum amount of water necessary to make a complete solution;
- (3) Fill clean test fluid tank with fresh water with a quantity 1.2 times the volume of the total quantity of water in Test Fluid C needed for the test described in §§162.050-23 and 162.050-35;
- (4) Operate the centrifugal pump B running at a speed of not less than 3,000 rpm with a flow rate at which the volume of the test fluid has been changed out at least once per minute;
- (5) Add the surfactant mixture from paragraph (b)(2) of this section first, followed by oil and suspended solids (iron oxides) respectively, both 1.2 times of the required amounts, to the fresh water in the tank;
- (6) To establish a stable emulsion keep running the centrifugal pump B

Coast Guard, DHS

§ 162.050-20

for one hour and confirm no oil floats on the surface of the test fluid; and

(7) After the one hour stated in paragraph (b)(6) of this section, keep running the centrifugal pump B at reduced

speed to approximately 10 percent of original flow rate, until the end of the test.

FIGURE 162.050-20

WORKSHEET FOR DETERMINING CONSTITUENTS OF TEST FLUID C:

1. Determine volumetric flow rate of separator in m<sup>3</sup>/hr.
2. Determine net volume of fluid needed for testing with fluid C:
  - a. Multiply volumetric flow rate x 3 hours = Net volume (assumes conditioning time of approximately 30 minutes added to 2-1/2-hour test period)
3. Determine volume of Test Fluid C:
  - a. Multiply net volume \* 0.06 = Fluid C volume
4. Determine amounts of constituents:
  - a. Volume of Test Fluid C: 1.2 x Net Volume;
  - b. Volume of fresh water in Test Fluid C: 0.9478 x volume of Test Fluid C;
  - c. Weight of Test Fluid A: 25 x volume of Test Fluid C;
  - d. Weight of Test Fluid B: 25 x volume of Test Fluid C;
  - e. Weight of surfactant: 0.5 x volume of Test Fluid C; and
  - f. Weight of iron oxide 1.7 x volume of Test Fluid C.
  - g. Specifications for tank of Test Fluid .C.

(1) The tank should be of a cylindrical shape, as illustrated in the diagram below. The level of the water should be:  $2D \geq H \geq 0.5D$ , when preparing Test Fluid C.

(2) Outlet going to centrifugal pump B should be placed at as low a position to the tank as possible.

(3) Inlet to the tank should be fitted at the center of tank bottom so that the mixture flows upward to obtain uniform and stable emulsion.

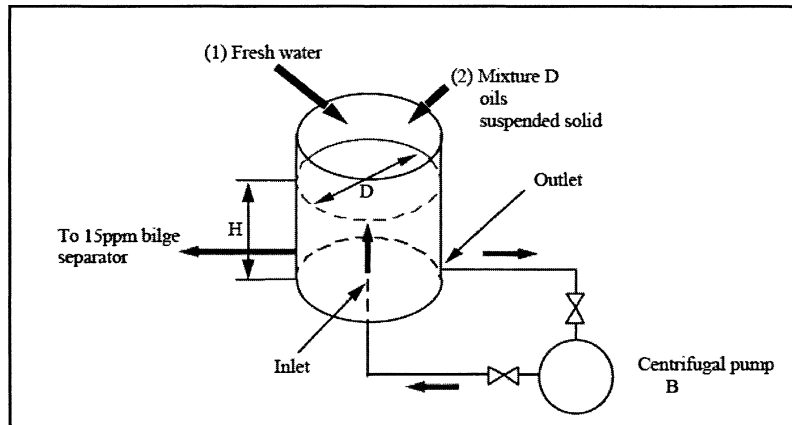

Figure 3 - Tank of Test Fluid "C"

**Note:**

- (1) The tank should be of a cylindrical shape. The level of the water should be:

$$2D \geq H \geq 0.5D, \text{ when preparing Test Fluid "C".}$$

- (2) Outlet going to centrifugal pump B should be placed at as low a position to the tank as possible.
- (3) Inlet to the tank should be fitted at the center of tank bottom so that the mixture flows upward to obtain uniform and stable emulsion.



Example:

1. Bilge separator is rated at  $2\text{m}^3/\text{hr}$ ;
2. Net volume needed for the test: Volume of test water:  
 $2\text{m}^3 \times 3 \text{ hours} = 6\text{m}^3$ ;
3. Volume test Fluid C: 6 percent of test water =  $0.06 \times 6\text{m}^3 = 0.36\text{m}^3$ ;
4. Actual volume to be prepared:
  - a. Volume of Test Fluid C to be prepared: 1.2 times of the Net Volume of Test Fluid C =  $1.2 \times 0.36 = 0.432\text{m}^3$ ;
  - b. Volume of fresh water in Test Fluid C:  $(947.8\text{g}/1000\text{g})$  of Test Fluid C =  $0.9478 \times 0.432 = 0.4094\text{m}^3$ ;
  - c. Weight of Test Fluid A:  $(25\text{g}/1000\text{g})$  of Test Fluid C =  $25/1000 \times 0.432 \times 1000 = 10.8\text{kg}$ ;
  - d. Weight of Test Fluid B:  $(25\text{g}/1000\text{g})$  of Test Fluid C =  $25/1000 \times 0.432 \times 1000 = 10.8\text{kg}$ ;
  - e. Weight of surfactant:  $(0.5\text{g}/1000\text{g})$  of Test Fluid C =  $0.5/1000 \times 0.432 \times 1000 = 0.216\text{kg}$ ; and
  - f. Weight of iron oxide:  $(1.7\text{g}/1000\text{g})$  of Test Fluid C =  $1.7/1000 \times 0.432 \times 1000 = 0.734\text{kg}$ .

[USCG-2004-18939, 74 FR 3385, Jan. 16, 2009]

**§ 162.050-21 Separator: Design specification.**

(a) A separator must be designed to operate in each plane that forms an angle of  $22.5^\circ$  with the plane of its normal operating position.

(b) The electrical components of a separator that are to be installed in an explosive atmosphere must be approved by an independent laboratory as components that Underwriters Laboratories Standard 913 (dated April 8, 1976) (incorporated by reference, see § 162.050-4) defines as intrinsically safe

for use in a Class I, Group D hazardous location.

(c) Each separator component that is a moving part must be designed so that its movement during operation of the separator does not cause formation of static electricity.

(d) Each separator must be designed in accordance with the applicable requirements in subchapters F and J of this chapter.

(e) Each separator must be designed to be operated both automatically and

manually. Each separator must be capable of operating automatically for at least 24 hours.

(f) Each separator must be designed so that adjustments to valves or other equipment are not necessary to start it.

(g) Each part of a separator that is susceptible to wear and tear must be readily accessible for maintenance in its installed position.

(h) A separator must be designed so that it does not rely in whole or in part on dilution of influent mixtures as a means of performing its function.

[CGD 76-088a, 44 FR 53359, Sept. 13, 1979, as amended by USCG-2004-18939, 74 FR 3388, Jan. 16, 2009]

**§ 162.050-23 Separator: Approval tests.**

(a) *Test Conditions.* (1) Each test described in this section must be performed at a throughput and influent pressure equal to the maximum throughput and pressure at which the separator being tested is designed to operate. The tests and each of the steps in the tests must be carried out in the order described in this section. Each test must be performed without time delay between steps in the test.

(2) A test rig of the type described in § 162.050-17 must be used in performing each test.

(3) If a separator has a supply pump, it must be tested using that pump. If a separator does not have a supply pump, it must be tested using the mixture pump on the test rig.

(4) The influent water used in each test must be clean fresh water or clean fresh water in solution with sodium chloride. In either case, the relative density of the water must be no greater than 1.015 at 20 °C.

(5) Each test must be conducted at an ambient temperature of between 10 °C and 30 °C.

(6) The oil content of each sample must be measured using the method described in § 162.050-39.

(7) Influent oil content must be determined during testing by measuring the flow rates of the oil and water that are mixed to form the influent or by use of an oil content meter on the inlet piping of the test rig. If an oil content meter is used, a sample of influent and a meter reading must be taken at the

beginning of each test. If the meter reading is not within  $\pm 10$  percent of the oil content of the sample, the meter readings subsequently taken during the test are unacceptable test results.

(8) When collecting a sample at a sample point that has a stop cock, the first minute of fluid flow through the stop cock must not be included in the sample collected.

(9) In each test, the separator must be operated in accordance with the procedures described in its instruction manual.

(10) No maintenance, including replacement of parts, may be performed on a separator during or between the tests described in this section.

(11) A 1 liter sample of each oil to be used in testing must be taken and provided for use in the sample analysis required by § 162.050-39.

(12) The separator may not be operated manually in Test No. 5A.

(13) If a separator has an integral bilge alarm, the separator must be tested with the bilge alarm installed.

(b) The following tests must be conducted using Test Fluid A:

(1) *Test No. 1A.* The separator is filled with water and started. Next, the separator is fed with pure Test Fluid A for at least 5 minutes and then with a mixture of Test Fluid A and water influent containing Test Fluid A content of between 5,000 and 10,000 ppm until a steady flow rate at a steady, constant ppm occurs. After the flow rate is steady, the influent is fed to the separator for 30 minutes. Samples of separated water effluent are taken after the first 10 and 20 minutes. At the end of the 30-minute period, the air cock on the test rig is opened and, if necessary, the oil and water supply valves are closed to stop the flow of influent. A sample is then taken of the separated water effluent as the effluent flow ceases.

(2) *Test No. 2A.* Repeat Test No. 1A in paragraph (b)(1) of this section using an influent containing approximately 25 percent oil and 75 percent water. Percentage is on a by volume basis.

(3) *Test No. 3A.* The separator is fed with 100 percent Test Fluid A until Fluid A is discharged at the oil discharge outlet of the separator at essentially the same rate that oil is being

fed to the separator. The separator is then fed with 100 percent Test Fluid A for 5 additional minutes. If any oily mixture is discharged from the separated water outlet on the separator during the test, that observation is recorded.

(4) *Test No. 4A.* The separator is fed with water for 15 minutes. Samples of the separated water effluent are taken at the beginning of the test and after the first 10 minutes.

(5) *Test No. 5A.* The separator is operated automatically for 3 hours. During the test, the separator is continuously fed with an influent varying from water to a mixture of 25 percent Test Fluid A in water and back to water every 15 minutes. The Test Fluid A concentration in the influent is varied in at least five equal increments during each 15-minute period and the time intervals between the incremental changes are equal. During the last hour, the separator must be inclined at an angle of 22.5° with the plane of its normal operating position. During the last time increment in which the unit is fed a 25 percent Fluid A mixture, a sample of the separated water effluent is taken. If the separator stops at any time during this test, that observation is recorded.

(c) The following tests must be conducted using Test Fluid B:

(1) *Test No. 1B.* Repeat Test No. 1A in paragraph (b)(1) of this section using Test Fluid B; and

(2) *Test No. 2B.* Repeat Test No. 2A in paragraph (b)(2) of this section using Test Fluid B.

(d) The following tests must be conducted using Test Fluid C: *Test No. 1C.* The separator is fed with a mixture composed of 6 percent Test Fluid C and 94 percent water by volume such that the emulsified Test Fluid C content is approximately 3,000 ppm in the test water until a steady flow rate occurs. After the flow rate is steady, the influent containing the 6 percent Test Fluid C solution is fed to the separator operating automatically for 3 hours. Samples of separated water effluent are taken at 50 minutes and 100 minutes. At the end of the 3-hour period, the air cock on the test rig is opened and, if necessary, the oil and water supply valves are closed to stop the flow of in-

fluent. A sample is then taken of the separated water effluent as the effluent flow ceases.

[CGD 76-088a, 44 FR 53359, Sept. 13, 1979, as amended by USCG-2004-18939, 74 FR 3388, Jan. 16, 2009]

**§ 162.050-25 Cargo monitor: Design specification.**

(a) This section contains requirements that apply to cargo monitors.

(b) Each monitor must be designed so that it is calibrated by a means that does not involve manually mixing a known quantity of oil and a known quantity of water to form a mixture and manually feeding the mixture into the monitor.

(c) The electrical components of a monitor that are to be installed in an explosive atmosphere must be approved by an independent laboratory as components that Underwriters Laboratories Standard 913 (dated April 8, 1976) (incorporated by reference, see § 162.050-4) defines as intrinsically safe for use in a Class I, Group D hazardous location.

(d) Each monitor component that is a moving part must be designed so that its movement during operation of the monitor does not cause formation of static electricity.

(e) A monitor must be designed to operate in each plane that forms an angle of 22.5° with the plane of its normal operating position.

(f) Each monitor must be designed in accordance with the applicable requirements contained in subchapters F and J of this chapter.

(g) Each monitor must be designed so that it records each change in oil content of the mixture it is measuring within 20 seconds after the change occurs.

(h) Each monitor must have a device that produces a warning signal and a signal that can be used to actuate valves in a vessel's fixed piping system, when—

(1) The oil content of the mixture being measured exceeds the concentration limit set by the operator of the monitor; and

(2) Malfunction, breakdown, or other failure of the monitor occurs.

## § 162.050-27

## 46 CFR Ch. I (10-1-11 Edition)

(i) Each monitor must have a means to determine whether it is accurately calibrated.

[44 FR 53359, Sept. 13, 1979, as amended by CGD 76-088c, 48 FR 45727, Oct. 6, 1983; USCG-2004-18939, 74 FR 3389, Jan. 16, 2009]

### § 162.050-27 Oil content meter: Approval tests.

This section contains requirements that apply to performing each test.

(a) *Test conditions.* (1) The tests and each step in the tests must be carried out in the order described in this section. Each test must be performed without time delay between steps in the test. No maintenance, including replacement of parts, may be performed on the meter during or between the tests described in this section.

(2) A test rig of the type described in § 162.050-19 must be used when performing each test.

(3) Each mixture used during the tests must be prepared by combining oil supplied from the oil injection pipe of the test rig and water supplied from the mixture tank of the test rig. However, if the flow of oil through the oil injection pipe becomes intermittent, oil and water may be combined in the mixture tank to form the mixture.

(4) A mixture may be circulated through a meter only once during testing.

(5) Unless otherwise provided in a specific test, the water used in each test must be clean, fresh water.

(6) The oil used in each test, except Test No. 2 in paragraph (c) of this section, must be Arabian light crude oil.

(7) Each test must be performed at an ambient temperature of between 10 °C and 30 °C.

(8) Unless otherwise provided in a specific test, each test must be performed at the maximum mixture pressure, the maximum flow rate, and the power supply ratings at which the meter is designed to operate.

(9) The particulate contaminant described in Test No. 5 in paragraph (f) of this section, if not attapulgate, must be of a type that does not lose more than 3 percent of its weight after ignition and must be insoluble in a 500 ppm mixture.

(10) In each test the meter must be operated in accordance with the proce-

dures described in its instructions manual.

(11) Unless otherwise provided in a specific test, the centrifugal pump shown in Figure 162.050-19 in § 162.050-19 must be operated at 1,000 revolutions per minute or more in each test.

(12) Whenever the oil content of a mixture is recorded, a sample of the mixture must also be taken. The oil content of the sample must be measured using the method described in § 162.050-39.

(13) A one-liter sample of each oil to be used in testing must be taken and provided for use in the sample analysis required by § 162.050-39.

(b) *Test No. 1 Calibration and Zero Test.* The meter is calibrated and zeroed to manufacturer's instructions. It is then fed with water for 15 minutes and then with mixtures in the following concentrations: 15 ppm, 50 ppm, 100 ppm, and each additional concentration, in increments of 50 ppm up to the highest oil concentration that can be read on the meter. Each mixture is fed to the meter in the order listed in Table 162.050-27(c) for 15 minutes. Water is fed to the meter for a 15-minute period between each mixture. At the end of each 15-minute period, an oil content reading is obtained and recorded, and a calibration curve must be created.

(c) *Test No. 2 Response to Different Oil Types Test.* (1) If the meter is designed for use with crude oils, it is fed with a mixture of water and the first oil listed in Table 162.050-27(c) at the following concentrations: 15 ppm, 100 ppm, and a concentration that is 90 percent of the highest oil concentration in water that can be read on the meter. Each concentration is fed to the meter in the order listed until a steady reading occurs and is recorded. After each steady reading is recorded, the meter is fed with water for 15 minutes. At the end of each 15-minute period of feeding the meter with water, an oil content reading is again obtained and recorded, and a calibration curve must be created.

(2) The steps described in paragraph (c)(1) of this section are repeated using each of the other oils listed in Table 162.050-27(c). A calibration curve must be created for each oil tested.

TABLE 162.050-27(c)—OIL TYPE AND CHARACTERISTICS

Oil type	Characteristics
Sahara blend crude oil .....	Density—low. Viscosity—low. Pour point—very low. Producing country—Algeria. General description—mixed base.
Arabian light crude oil .....	Density—medium. Viscosity—medium. Pour point—low. Producing country—Saudi Arabia. General description—mixed base.
Nigerian medium crude oil .....	Density—high. Viscosity—medium. Pour point—low. Producing country—Nigeria. General description—naphthenic base.
Bachaquero 17 crude oil .....	Density—very high. Viscosity—very high. Pour point—low. Producing country—Venezuela. General description—asphaltic base.
Minas crude oil .....	Density—medium. Viscosity—high. Pour point—very high. Producing country—Indonesia. General description—paraffinic base.
Residual fuel oil .....	Bunker C or No. 6 Fuel Oil.

(3) If any oil listed in Table 162.050-27(c) is unavailable, an oil with similar properties may be substituted in testing.

(4) If the meter will be used with refined oil products, the steps described in paragraph (c)(1) of this section are performed using each of the following:

- (i) Leaded regular grade automotive gasoline;
- (ii) Unleaded automotive gasoline;
- (iii) Kerosene; and
- (iv) Light diesel or No. 2 fuel oil.

(5) If the meter will be used with category C and D oil-like noxious liquid substances to meet the requirements of 33 CFR 151.41(b), the tests described in paragraphs (c) and (d) of this section are to be performed using the substances for which approval is sought.

(d) *Test No. 3 Response Time Test.* (1) The meter is fed with water, zeroed, and then fed with a 100 ppm mixture. The time at which the meter first detects oil in the mixture, the times of reading 63 ppm and 90 ppm, and the time of reaching the highest steady reading of oil content are recorded. The oil content of the mixture at the highest steady reading is also recorded.

(2) The metering pump is turned off and the time at which the highest reading starts to decrease, the times of

reading 37 ppm and 10 ppm, and the time of returning to the lowest steady oil content reading are recorded. The oil content of the mixture at the lowest steady reading is also recorded.

(3) The time interval between first detecting oil in the mixture and reading 63 ppm, and the time interval between the first decrease in the highest reading and reading 37 ppm, are averaged and recorded as the response time for the meter.

(e) *Test No. 4 Oil Fouling and Calibration Shift Test.* (1) The meter is fed with water, zeroed, and then fed with a mixture containing 10 percent oil for one minute. The following must be recorded:

- (i) Time at which the meter first detects oil;
- (ii) Time of reading 15 ppm;
- (iii) Time of reading 100 ppm;
- (iv) Time of exceeding the highest oil concentration that can be read on the meter;
- (v) Time of returning to the highest oil concentration that can be read on the meter;
- (vi) Time of returning to a reading of 100 ppm;
- (vii) Time of returning to a reading of 15 ppm; and

(viii) Time of returning to the lowest steady oil content reading.

(2) The oil content of the mixture at the lowest steady reading described in paragraph (e)(1)(viii) of this section is recorded.

(3) The meter is fed with water, zeroed, and then fed with oil for 1 minute after which the flow of water is resumed. The times described in paragraph (e)(1) of this section are recorded.

(4) If it is necessary to clean the meter after each oil-fouling test for it to return to a zero reading, this fact and the time required to clean and recalibrate the meter must be noted and recorded in the test report.

(5) The meter is fed with a 100 ppm mixture until a steady oil content reading is obtained and recorded.

(f) *Test No. 5 Contaminant Test.* (1) The meter is fed with a 15 ppm mixture until a steady oil content reading is obtained and recorded.

(2) The meter is fed with a 15 ppm oil mixture of contaminated water consisting of not less than 270 ppm by weight of the clay mineral attapulgite, or similar contaminant that is stable in both fresh and salt water and 30 ppm by weight of iron oxides. The test contaminant should have a particle size distribution with about 30 percent of 10 microns or less and a maximum particle size of 100 microns. The oil content reading, when steady, is recorded.

(3) Each of the two contaminants will be mixed sequentially in the following manner: the mixing of attapulgite shall be for a period of not less than 15 minutes so that a homogeneous suspension is formed; then, iron oxides will be added for an additional period of not less than 10 minutes. The mixing process should maintain the contaminants in suspension throughout the test period.

(4) The test in paragraph (f)(2) of this section is repeated for 100 and 300 ppm oil mixtures in contaminated water.

(g) *Test No. 6 Air Entrainment Test.* (1) The meter is fed with a 15 ppm mixture until a steady oil content reading is obtained and recorded.

(2) Air is injected into the meter test rig before the sample pump or, in the absence of such pump, immediately before any conditioning unit used to pre-

pare the mixture for measurement. Injection must be by needle having an orifice dimension not exceeding 0.5 mm in diameter arranged in line with the sample flow. The quantity of air injected must be 1 percent of the designated flow rate of the sample pump or conditioning unit at the point of injection.

(3) Air must be delivered to the system by direct injection or pump via a suitable measuring device designed to permit a constant controllable flow rate within  $\pm 10$  percent of the required rate of injection for an uninterrupted effective test period of not less than 15 minutes.

(4) The oil content reading, when steady, is recorded.

(h) *Test No. 7 Oil Particle Size—Centrifugal Pump Test.* (1) The meter is fed with a 100 ppm mixture until a steady oil content reading is obtained and recorded.

(2) The meter is fed with a 100 ppm mixture that has first passed through the centrifugal pump of the test rig. The pump is run at one-fourth of its design speed. The oil content reading, when steady, is recorded.

(3) The steps described in paragraph (h)(2) of this section are repeated with the pump running at one-half of its design speed and then repeated at its design speed.

(i) *Test No. 8 Temperature Test.* (1) The steps described in paragraph (h)(1) of this section are repeated.

(2) The temperature of the mixture is adjusted to 10 °C and the flow continued until a steady oil content reading is obtained and recorded.

(3) The steps described in paragraph (i)(2) of this section are repeated with the temperature of the mixture at 65 °C or the highest mixture temperature at which the meter is designed to operate, whichever is lower.

(j) *Test No. 9 Sample Pressure or Flow Test.* (1) The steps described in paragraph (h)(1) of this section are repeated.

(2) If the meter has a positive displacement mixture pump, the mixture pressure is lowered to one-half of the meter's maximum design pressure. If the meter has a centrifugal mixture

pump, or is not equipped with a mixture pump, the mixture flow rate is reduced to one-half of the meter's design flow rate. The reduced flow rate or mixture pressure is maintained until a steady oil content reading is obtained and recorded.

(3) If the meter has a positive displacement mixture pump, the mixture pressure is increased to twice the meter's design pressure. If the meter has a centrifugal mixture pump or does not have a mixture pump, the mixture flow rate is increased to twice the meter's maximum design flow rate. The increased flow rate or mixture pressure is maintained until a steady oil content reading is obtained and recorded.

(k) *Test No. 10 Shutoff Test.* (1) The steps described in paragraph (h)(1) of this section are repeated.

(2) The water and metering pumps on the test rig are stopped for 8 hours after which the steps described in paragraph (h)(1) of this section are repeated.

(1) *Test No. 11 Supply Voltage Variation Test.* (1) The supply voltage to the meter is increased to 110 percent of its design supply voltage. The meter is then fed a 100 ppm mixture for one hour. At the end of the 1-hour period, an oil content reading is obtained and recorded.

(2) The steps described in paragraph (1)(1) of this section are repeated with the supply voltage to the meter lowered to 90 percent of its design supply voltage.

(3) Upon completing the steps described in paragraph (1)(2) of this section, the supply voltage to the meter is returned to the design rating.

(4) The steps described in paragraphs (1)(1) through (1)(3) of this section are repeated varying each power supply to the meter in the manner prescribed in those steps for supply voltage.

(m) *Test No. 12 Calibration and Zero Drift Test.* (1) The meter is calibrated and zeroed.

(2) The steps described in paragraph (h)(1) of this section are repeated.

(3) A 100 ppm mixture is fed to the meter for 8 hours. At the end of the 8-hour period, an oil content reading is obtained and recorded.

(4) The meter is fed with water until a steady oil content reading is obtained and recorded.

(n) *Test No. 13 Shutdown and Restart Test.* (1) All power to the meter is shut-off for one week. After 1 week the meter is restarted, zeroed, and calibrated.

(2) The meter is fed with a 100 ppm mixture for 1 hour. An oil content reading is then obtained and recorded.

(3) The meter is fed with water for 1 hour. An oil content reading is then obtained and recorded.

(4) The steps described in paragraphs (n)(2) and (n)(3) of this section are repeated three additional times. During the last hour in which the meter is fed with a 100 ppm mixture, the meter is inclined at an angle of 22.5° with the plane of its normal operating position.

[USCG-2004-18939, 74 FR 3389, Jan. 16, 2009]

#### § 162.050-33 Bilge alarm: Design specification.

(a) This section contains requirements that apply to bilge alarms.

(b) Each bilge alarm must be designed to meet the requirements for an oil content meter in §162.050-25(b) through (f) and 162.050-25(i), and the requirements in this section.

(c) Each bilge alarm must have a device that produces a warning signal, and a signal that can be used to actuate stop valves in a vessel's fixed piping system, when—

(1) the oil content of the mixture being measured by the bilge alarm exceeds 15 ppm  $\pm$ 5 ppm, and

(2) malfunction, breakdown, or other failure of the bilge alarm occurs.

(d) Each bilge alarm must have a ppm display. Emulsions and/or the type of oil must not affect the ppm display. Calibrating the bilge alarm must not be necessary once installed on board the vessel, however, onboard testing in accordance with the manufacturer's operating instructions is permitted for the purposes of checking instrument drift and repeatability of the instrument reading, as well as the ability to re-zero the instrument. The accuracy of the readings must at all times remain within the limits described in paragraph (c)(1) of this section.

(e) Each bilge alarm must be designed so that it displays each change

§ 162.050-35

46 CFR Ch. I (10-1-11 Edition)

in oil content of the mixture it is measuring within 5 seconds after the change occurs.

(f) Access to the bilge alarm must require the breaking of a seal, except when—

- (1) Re-zeroing the instrument;
- (2) Checking the instrument drift; or
- (3) Checking the repeatability of the instrument reading.

(g) Each bilge alarm must activate its alarm whenever clean water is used for cleaning or zeroing purposes.

(h) The bilge alarm must record date, time, alarm status, and operating status of the 15 ppm bilge separator. The recording device must also store data for at least 18 months and be able to display or print a protocol. In the event the 15 ppm bilge alarm is replaced, means must be provided to ensure the data recorded remains available on board for 18 months.

[CGD 76-088a, 44 FR 53359, Sept. 13, 1979, as amended by USCG-2004-18939, 74 FR 3391, Jan. 16, 2009]

**§ 162.050-35 Bilge alarm: Approval tests.**

This section contains requirements that apply to bilge alarms.

(a) *Test Conditions.* (1) Each test must be conducted under the conditions prescribed for meters in §162.050-27(a)(1) through (a)(5), (a)(7), (a)(8), (a)(10), (a)(11), and (a)(13).

(2) The tests in this section must be performed using test fluids described in §162.050-20.

(3) The oil content of each sample must be measured using the method described in §162.050-39.

(b) *Test No. 1A Calibration and Zero Test.* (1) The bilge alarm is calibrated and zeroed to manufacturer's instructions.

(2) It is then fed with water for 15 minutes and then with a mixture of Test Fluid A and water in the following concentrations: 0 ppm, 15 ppm, and the highest oil concentration that can be read on the monitor. A sample of the mixture causing actuation of the alarm is taken. The alarm is then fed with water for 15 minutes.

(3) Repeat steps in paragraphs (b)(2) of this section first using Test Fluid B and then again with Test Fluid C. Collect samples as required in the test for

each run of Test Fluid B and Test Fluid C.

(4) If the bilge alarm must be calibrated and re-zeroed between test fluids, this must be noted in the test report.

(c) *Test No. 2A Contaminant Test.* (1) The bilge alarm is fed for 5 minutes with a 10 ppm mixture of Test Fluid B and water. At the end of the 5-minute period an oil content reading is obtained and recorded.

(2) The bilge alarm is then fed for 5 minutes with a 10 ppm mixture of Test Fluid B and water contaminated with a 10 ppm concentration of iron oxide. Any change in the bilge alarm reading during the 5 minutes is recorded.

(3) Repeat steps in paragraphs (c)(1) and (2) of this section using iron oxide concentrations of 50 ppm and 100 ppm.

(4) The bilge alarm is then fed for 5 minutes with a 10 ppm mixture of Test Fluid B and water. At the end of the 5-minute period an oil content reading is obtained and recorded.

(5) The bilge alarm is fed for 5 minutes with a 10 ppm mixture of Test Fluid B and fresh water with 6 percent sodium chloride. Any change in the bilge alarm reading is recorded.

(d) *Test No. 3A Sample Pressure or Flow Test.* (1) The bilge alarm is fed with a mixture of Test Fluid B and water and the test fluid content of the mixture is increased until the bilge alarm actuates. The ppm display is recorded and a sample of the mixture causing actuation of the alarm is taken.

(2) If the alarm has a positive displacement mixture pump, the mixture pressure is reduced to one-half of the alarm's maximum design pressure. If the alarm has a centrifugal mixture pump or is not equipped with a mixture pump, the mixture flow rate is reduced to one-half of the alarm's maximum design flow rate. After reduction of pressure or flow rate, the oil content in the mixture is increased until the alarm actuates. The ppm display is recorded and a sample of the mixture causing actuation of the alarm is taken.

(3) If the alarm has a positive displacement mixture pump, the influent pressure is increased to twice the alarm's minimum design pressure. If the alarm has a centrifugal mixture



pump or if the alarm is not equipped with a mixture pump, the influent flow rate is increased to twice the alarm's maximum design flow rate. After increasing the pressure or flow rate, the oil content in the mixture is increased until the alarm actuates. The ppm display is recorded and a sample of the mixture causing actuation is taken.

(e) *Test No. 4A Shutoff Test.* (1) The steps described in paragraph (d)(1) of this section are repeated.

(2) The metering and water pumps of the test rig are stopped for 8 hours with the bilge alarm left turned on with no other changes made.

(3) The metering and water pumps are started and the Test Fluid B content of the mixture is increased until the bilge alarm actuates. A sample of the mixture causing actuation is taken. The bilge alarm ppm display readings before and after the 8-hour period will be recorded.

(f) *Test No. 5A Supply Voltage Variation Test.* (1) The supply voltage to the bilge alarm is raised to 110 percent of its design supply voltage. The bilge alarm is fed with a mixture of Test Fluid B and water and the test fluid content of the mixture is increased until the bilge alarm actuates. The ppm display is recorded and a sample of the mixture causing actuation is taken.

(2) The supply voltage to the alarm is lowered to 90 percent of its design supply voltage. The bilge alarm is fed with a mixture of Test Fluid B and water and the test fluid content of the mixture is increased until the bilge alarm actuates. The ppm display is recorded and a sample of the mixture causing actuation is taken.

(3) Upon completion of the steps described in paragraph (f)(2) of this section, the supply voltage to the alarm is returned to its design value.

(4) The steps described in paragraphs (f)(1) through (f)(3) of this section are repeated varying each other power supply to the alarm in the manner prescribed in those steps for supply voltage.

(g) *Test No. 6A Calibration and Zero Drift Test.* (1) The steps described in paragraph (b)(1) of this section are repeated and then the steps in paragraph (d)(1) of this section are repeated.

(2) The bilge alarm is fed with a 15 ppm mixture of Test Fluid B and water for eight hours and any calibration drift is recorded. Samples of the mixture must be taken at the beginning of the test and at 2-hour intervals until the completion of the 8-hour period.

(3) Following the steps in paragraph (g)(2) of this section, the bilge alarm must be run on clean, oil-free water only and any zero drift must be recorded.

(h) *Test No. 7A Response Time Test.* (1) The bilge alarm is fed with a 40 ppm mixture of Test Fluid B and water until the bilge alarm actuates. The time of turning on the metering pump of the test rig and the time of alarm actuation are recorded. The flow rate on the flow meter of the test rig is also recorded.

(i) *Test No. 8A Shutdown and Restart Test.* (1) All power to the bilge alarm is shutoff for 1 week. After 1 week the alarm is then restarted, zeroed, and calibrated.

(2) The steps described in paragraph (d)(1) of this section are repeated. Water is then fed to the bilge alarm for 1 hour.

(3) The steps described in paragraph (i)(2) of this section are repeated seven additional times. During the last hour, the alarm must be inclined at an angle of 22.5° with the plane of its normal operating position.

[USCG-2004-18939, 74 FR 3391, Jan. 16, 2009]

#### § 162.050-37 Vibration test.

(a) Equipment submitted for Coast Guard approval must first be tested under the conditions prescribed in paragraph (b) of this section. The test must be performed at an independent laboratory that has the equipment to subject the item under test to the vibrating frequencies and amplitudes prescribed in paragraph (b) of this section. The test report submitted with the application for Coast Guard approval must be prepared by the laboratory and must contain the test results.

(b)(1) Each oil content meter and bilge alarm and each control of a separator must be subjected to continuous sinusoidal vibration in each of the following directions for a 2 hour period in each direction:

(i) Vertically up and down;

## § 162.050-39

(ii) Horizontally from side to side; and

(iii) Horizontally from end to end.

(2) The vibrating frequency must be 80 Hz, except that the vibrating frequency of equipment that has a resonant frequency between 2 Hz and 80 Hz must be the resonant frequency. If the vibrating frequency is between 2 Hz and 13.2 Hz, the displacement amplitude must be  $\pm 1$  mm. If the vibrating frequency is between 13.2 Hz and 80 Hz, the acceleration amplitude must be  $\pm [(.7)(\text{gravity})]$ .

(c) After completion of the tests specified in paragraph (b) of this section, a search must again be made for resonance and any significant change in the vibration pattern must be noted in the test report.

[CGD 76-088a, 44 FR 53359, Sept. 13, 1979, as amended by USCG-2004-18939, 74 FR 3392, Jan. 16, 2009]

## § 162.050-39 Measurement of oil content.

The collection and testing of all samples of oil in water from the required test will be accomplished in accordance with ISO 9377-2 (2000), Water Quality—Determination of hydrocarbon oil index-Part 2: Method Using solvent extraction and Gas Chromatography (incorporated by reference, see § 162.050-4).

[USCG-2004-18939, 74 FR 3393, Jan. 16, 2009]

## PART 163—CONSTRUCTION

### Subpart 163.001 [Reserved]

### Subpart 163.002—Pilot Hoist

Sec.

- 163.002-1 Scope.
- 163.002-3 Applicable technical regulations.
- 163.002-5 Definitions.
- 163.002-7 Independent laboratory.
- 163.002-9 Approval procedure.
- 163.002-11 Materials.
- 163.002-13 Construction.
- 163.002-15 Performance.
- 163.002-17 Instructions and marking.
- 163.002-21 Approval tests.
- 163.002-25 Marking.
- 163.002-27 Production tests and examination.

### Subpart 163.003—Pilot Ladder

- 163.003-1 Scope.
- 163.003-3 ASTM standard.

## 46 CFR Ch. I (10-1-11 Edition)

- 163.003-7 Independent laboratory.
- 163.003-9 Approval procedure.
- 163.003-11 Materials.
- 163.003-13 Construction.
- 163.003-15 Performance.
- 163.003-17 Strength.
- 163.003-21 Approval tests.
- 163.003-25 Marking.
- 163.003-27 Production tests and examination.

AUTHORITY: 46 U.S.C. 3306, 3703, 5115; E.O. 12234, 45 FR 58801, 3 CFR, 1980 Comp., p. 277; 49 CFR 1.46.

SOURCE: CGFR 50-30, 16 FR 1086, Feb. 6, 1951, unless otherwise noted.

### Subpart 163.001 [Reserved]

### Subpart 163.002—Pilot Hoist

SOURCE: CGD 74-140, 46 FR 63287, Dec. 31, 1981, unless otherwise noted.

#### § 163.002-1 Scope.

(a) This subpart contains standards and approval and production tests for pilot hoists used on merchant vessels.

(b) The requirements in this subpart apply to a pilot hoist designed for use along a vertical portion of a vessel's hull.

#### § 163.002-3 Applicable technical regulations.

(a) This subpart makes reference to the following Coast Guard regulations in this chapter:

- (1) Subpart 58.30 (Fluid Power and Control Systems).
  - (2) Section 94.33-10 (Description of Fleet Angle).
  - (3) Part 111 (Electrical System, General Requirements).
  - (4) Subpart 163.003 (Pilot Ladder).
- (b) [Reserved]

#### § 163.002-5 Definitions.

(a) *Maximum persons capacity* means—

(1) If the hoist has a rigid ladder, one person; or

(2) If the hoist has a platform, one person per square meter (10.75 sq. ft.) or fraction thereof of platform area (including hatch area);

(b) *Working load* means the sum of the weights of—

(1) The rigid ladder or lift platform, the suspension cables (if any) and the pilot ladder on a pilot hoist; and