

3 degrees, passing through point V<sub>1</sub>, and parallel to the Y axis.

S5.4 *Low speed vehicles.* Windshields of low speed vehicles must meet the ANSI/SAE Z26.1-1996 specifications for either AS-1 or AS-4 glazing.

S5.5 Item 4A Glazing. Item 4A glazing may be used in all areas in which Item 4 safety glazing may be used, and also for side windows rearward of the "C" pillar. I.e., Item 4A glazing may be used under Item 4A paragraph (b) of ANSI/SAE Z26.1-1996 only in side windows rearward of the "C" pillar.

S6. *Certification and marking.*

S6.1 A prime glazing material manufacturer must certify, in accordance with 49 U.S.C. 30115, each piece of glazing material to which this standard applies that is designed—

(a) As a component of any specific motor vehicle or camper; or

(b) To be cut into components for use in motor vehicles or items of motor vehicle equipment.

S6.2 A prime glazing manufacturer certifies its glazing by adding to the marks required by section 7 of ANSI/SAE Z26.1-1996, in letters and numerals of the same size, the symbol "DOT" and a manufacturer's code mark that NHTSA assigns to the manufacturer. NHTSA will assign a code mark to a manufacturer after the manufacturer submits a written request to the Office of Vehicle Safety Compliance, National Highway Traffic Safety Administration, 400 Seventh Street, SW., Washington, DC 20590. The request must include the company name, address, and a statement from the manufacturer certifying its status as a prime glazing manufacturer as defined in S4.

S6.3 A manufacturer or distributor who cuts a section of glazing material to which this standard applies, for use in a motor vehicle or camper, must—

(a) Mark that material in accordance with section 7 of ANSI/SAE Z26.1-1996; and

(b) Certify that its product complies with this standard in accordance with 49 U.S.C. 30115.

[37 FR 12239, June 21, 1972]

EDITORIAL NOTE: For FEDERAL REGISTER citations affecting § 571.205 see the List of CFR Sections Affected which appears in the Finding Aids section of the printed volume and on GPO Access.

**§ 571.205(a) Glazing equipment manufactured before September 1, 2006 and glazing materials used in vehicles manufactured before November 1, 2006.**

S1. *Scope.* This standard specifies requirements for glazing equipment manufactured before September 1, 2006 for use in motor vehicles and motor vehicle equipment, and specifies requirements for motor vehicles manufactured before November 1, 2006 and for replacement glazing for those vehicles. A manufacturer may, at its option, comply with 49 CFR 571.205 instead of this standard.

S2. *Purpose.* The purpose of this standard is to reduce injuries resulting from impact to glazing surfaces, to ensure a necessary degree of transparency in motor vehicle windows for driver visibility, and to minimize the possibility of occupants being thrown through the vehicle windows in collisions.

S3. *Application.* This standard applies to glazing equipment manufactured before September 1, 2006 for use in motor vehicles and motor vehicle equipment. In addition, this standard applies to the following vehicles manufactured before November 1, 2006: passenger cars, low speed vehicles, multipurpose passenger vehicles, trucks, buses, and motorcycles. This standard also applies to slide-in campers, and pickup covers designed to carry persons while in motion, manufactured before November 1, 2006.

S4. *Definitions*

*Bullet resistant shield* means a shield or barrier that is installed completely inside a motor vehicle behind and separate from glazing materials that independently comply with the requirements of this standard.

*Camper* means a structure designed to be mounted in the cargo area of a truck, or attached to an incomplete vehicle with motive power, for the purpose of providing shelter for persons.

*Glass-plastic glazing material* means a laminate of one or more layers of glass and one or more layers of plastic in which a plastic surface of the glazing faces inward when the glazing is installed in a vehicle.

§ 571.205(a)

49 CFR Ch. V (10–1–10 Edition)

*Motor home* means a multipurpose passenger vehicle that provides living accommodations for persons.

*Pickup cover* means a camper having a roof and sides but without a floor, designed to be mounted on and removable from the cargo area of a truck by the user.

*Slide-in camper* means a camper having a roof, floor, and sides, designed to be mounted on and removable from the cargo area of a truck by the user.

S5. Requirements

S5.1. Materials

S5.1.1 Glazing materials for use in motor vehicles, except as otherwise provided in this standard shall conform to the American National Standard “Safety Code for Safety Glazing Materials for Glazing Motor Vehicles Operating on Land Highways” Z-26.1-1977, January 26, 1977, as supplemented by Z26.1a, July 3, 1980 (hereinafter referred to as “ANS Z26”). However, Item 11B glazing as specified in that standard may not be used in motor vehicles at levels requisite for driving visibility, and Item 11B glazing is not required to pass Tests Nos. 17, 30, and 31.

S5.1.1.1 The chemicals specified for testing chemical resistance in Tests Nos. 19 and 20 of ANS Z26 shall be:

(a) One percent solution of nonabrasive soap.

(b) Kerosene.

(c) Undiluted denatured alcohol, Formula SD No. 30 (1 part 100-percent methyl alcohol in 10 parts 190-proof ethyl alcohol by volume).

(d) Gasoline, ASTM Reference Fuel C, which is composed of Isooctane 50 volume percentage and Toluene 50 volume percentage. Isooctane must conform to A2.7 in Annex 2 of the Motor Fuels Section of the 1985 *Annual Book of ASTM Standards*, Vol. 05.04, and Toluene must conform to ASTM Specification D362-84, *Standard Specification for Industrial Grade Toluene*. ASTM Reference Fuel C must be used as specified in:

(1) Paragraph A2.3.2 and A2.3.3 of Annex 2 of Motor Fuels, Section 1 in the 1985 *Annual Book of ASTM Standards*; and

(2) OSHA Standard 29 CFR 1910.106—“Handling Storage and Use of Flammable Combustible Liquids.” This incorporation by reference was approved by the Director of the Federal Register

in accordance with 5 U.S.C. 552(a) and in 1 CFR part 51. Copies may be inspected at the Technical Reference Library, NHTSA, 400 Seventh Street, SW., Room 5108, Washington, DC 20590, or at the Office of the Federal Register, 800 North Capitol Street, NW., Suite 700, Washington, DC 20408.

S5.1.1.2 The following locations are added to the lists specified in ANS Z26 in which item 4, item 5, item 8, and item 9 safety glazing may be used:

(a)–(i) [Reserved]

(j) Windows and doors in motor homes, except for the windshield and windows to the immediate right or left of the driver.

(k) Windows and doors in slide-in campers and pickup covers.

(l) Windows and doors in buses except for the windshield, windows to the immediate right or left of the driver, and rearmost windows if used for driving visibility.

(m) For Item 5 safety glazing only: Motorcycle windscreens below the intersection of a horizontal plane 380 millimeters vertically above the lowest seating position.

S5.1.1.3 The following locations are added to the lists specified in ANS Z26 in which item 6 and item 7 safety glazing may be used:

(a)–(i) [Reserved]

(j) Windows and doors in motor homes, except for the windshield, forward-facing windows, and windows to the immediate right or left of the driver.

(k) Windows, except forward-facing windows, and doors in slide-in campers and pickup covers.

(1) For item 7 safety glazing only:

(1) Standee windows in buses.

(2) Interior partitions.

(3) Openings in the roof.

S5.1.1.4 The following locations are added to the lists specified in ANS Z26 in which item 8 and item 9 safety glazing may be used:

(a)–(e) [Reserved]

(f) Windows and doors in motor homes, except for the windshield and windows to the immediate right or left of the driver.

(g) Windows and doors in slide-in campers and pickup covers.

S5.1.1.5 The phrase “readily removable” windows as defined in ANS Z26,

for the purposes of this standard, in buses having a GVWR of more than 4536 kilograms (10,000 pounds), shall include pushout windows and windows mounted in emergency exits that can be manually pushed out of their location in the vehicle without the use of tools, regardless of whether such windows remain hinged at one side to the vehicle.

S5.1.1.6 Multipurpose passenger vehicles. Except as otherwise specifically provided by this standard, glazing for use in multipurpose passenger vehicles shall conform to the requirements for glazing for use in trucks as specified in ANS Z26.

S5.1.1.7 Test No. 17 is deleted from the list of tests specified in ANS Z26 for Item 5 glazing material and Test No. 18 is deleted from the lists of tests specified in ANS Z26 for Item 3 and Item 9 glazing material.

S5.1.2 In addition to the glazing materials specified in ANS Z26, materials conforming to S5.1.2.1, S5.1.2.2, S5.1.2.3, S5.1.2.4, S5.1.2.5, S5.1.2.6, S5.1.2.7, S5.1.2.8, and S5.1.2.11 may be used in the locations of motor vehicles specified in those sections.

S5.1.2.1 Item 11C—Safety Glazing Material for Use in Bullet Resistant Shields. Bullet resistant glazing that complies with Tests Nos. 2, 17, 19, 20, 21, 24, 27, 28, 29, 30 and 32 of ANS Z26 and the labeling requirements of S5.1.2.5 may be used only in bullet resistant shields that can be removed from the motor vehicle easily for cleaning and maintenance. A bullet resistant shield may be used in areas requisite for driving visibility only if the combined parallel luminous transmittance with perpendicular incidence through both the shield and the permanent vehicle glazing is at least 60 percent.

S5.1.2.2 Item 12—Rigid Plastics. Safety plastics materials that comply with Tests Nos. 10, 13, 16, 19, 20, 21, and 24 of ANS Z26, with the exception of the test for resistance to undiluted denatured alcohol Formula SD No. 30, and that comply with the labeling requirements of S5.1.2.5, may be used in a motor vehicle only in the following specified locations at levels not requisite for driving visibility.

(a) Window and doors in slide-in campers and pickup covers.

(b) Motorcycle windscreens below the intersection of a horizontal plane 380 millimeters vertically above the lowest seating position.

(c) Standee windows in buses.

(d) Interior partitions.

(e) Openings in the roof.

(f) Flexible curtains or readily removable windows or in ventilators used in conjunction with readily removable windows.

(g) Windows and doors in motor homes, except for the windshield and windows to the immediate right or left of the driver.

(h) Windows and doors in buses, except for the windshield and window to the immediate right and left of the driver.

S5.1.2.3 Item 13—Flexible plastics. Safety plastic materials that comply with Tests Nos. 16, 19, 20, 22, and 23 or 24 of ANS Z26, with the exception of the test for resistance to undiluted denatured alcohol Formula SD No. 30, and that comply with the labeling requirements of S5.1.2.5 may be used in the following specific locations at levels not requisite for driving visibility.

(a) Windows, except forward-facing windows, and doors in slide-in campers and pickup covers.

(b) Motorcycle windscreens below the intersection of a horizontal plane 380 millimeters vertically above the lowest standing position.

(c) Standee windows in buses.

(d) Interior partitions.

(e) Openings in the roof.

(f) Flexible curtains or readily removable windows or in ventilators used in conjunction with readily removable windows.

(g) Windows and doors in motor homes, except for the windshield, forward-facing windows, and windows to the immediate right or left of the driver.

S5.1.2.4 Item 14—Glass Plastics. Glass-plastic glazing materials that comply with the labeling requirements of S5.1.2.10 and Tests Nos. 1, 2, 3, 4, 9, 12, 15, 16, 17, 18, 19, 24, 26, and 28, as those tests are modified in S5.1.2.9, Test Procedures for Glass-Plastics, may be used anywhere in a motor vehicle, except that it may not be used in windshields of any of the following vehicles: convertibles, vehicles that have

**§ 571.205(a)**

**49 CFR Ch. V (10–1–10 Edition)**

no roof, vehicles whose roofs are completely removable.

S5.1.2.5 Item 15A—Annealed Glass-Plastic for Use in All Positions in a Vehicle Except the Windshield. Glass-plastic glazing materials that comply with Tests Nos. 1, 2, 3, 4, 9, 12, 16, 17, 18, 19, 24, and 28, as those tests are modified in S5.1.2.9 Test Procedures for Glass-Plastics, may be used anywhere in a motor vehicle except the windshield.

S5.1.2.6 Item 15B—Tempered Glass-Plastic for Use in All Positions in a Vehicle Except the Windshield. Glass-plastic glazing materials that comply with Tests Nos. 1, 2, 3, 4, 6, 7, 8, 16, 17, 18, 19, 24, and 28, as those tests are modified in S5.1.2.9 Test Procedures for Glass-Plastics, may be used anywhere in a motor vehicle except the windshield.

S5.1.2.7 Item 16A—Annealed Glass-Plastic for Use in All Positions in a Vehicle Not Requisite for Driving Visibility. Glass-plastic glazing materials that comply with Tests Nos. 3, 4, 9, 12, 16, 19, 24, and 28, as those tests are modified in S5.1.2.9 Test Procedures for Glass-Plastics, may be used in a motor vehicle in all locations not requisite for driving visibility.

S5.1.2.8 Item 16B—Tempered Glass-Plastic for Use in All Positions in a Vehicle Not Requisite for Driving Visibility. Glass-plastic glazing materials that comply with Tests Nos. 3, 4, 6, 7, 8, 16, 19, 24, and 28, as those tests are modified in S5.1.2.9 Test Procedures for Glass-Plastics, may be used in a motor vehicle in all locations not requisite for driving visibility.

S5.1.2.9—Test Procedures for Glass-Plastics. (a) Tests Nos. 6, 7, 8, 9, 12, 16, and 18, shall be conducted on the glass side of the specimen, i.e., the surface which would face the exterior of the vehicle. Tests Nos. 17, 19, 24, and 26 shall be conducted on the plastic side of the specimen, i.e., the surface which would face the interior of the vehicle. Test No. 15 should be conducted with the glass side of the glazing facing the illuminated box and the screen, respectively. For Test No. 19, add the following to the specified list: an aqueous solution of isopropanol and glycol ether solvents in concentration no greater than ten percent or less

than five percent by weight and ammonium hydroxide no greater than five percent or less than one percent by weight, simulating typical commercial windshield cleaner.

(b) Glass-plastic specimens shall be exposed to an ambient air temperature of –40 degrees Celsius (plus or minus 5 degrees Celsius), for a period of 6 hours at the commencement of Test No. 28, rather than at the initial temperature specified in that test. After testing, the glass-plastic specimens shall show no evidence of cracking, clouding, delaminating, or other evidence of deterioration.

(c) Glass-plastic specimens tested in accordance with Test No. 17 shall be carefully rinsed with distilled water following the abrasion procedure and wiped dry with lens paper. After this procedure, the arithmetic means of the percentage of light scattered by the three specimens as a result of abrasion shall not exceed 4.0 percent.

(d) Data obtained from Test No. 1 should be used when conducting Test No. 2.

(e)(1) Except as provided in S5.1.2.9(e)(2), glass-plastic glazing specimens tested in accordance with Tests Nos. 9, 12, and 26 shall be clamped in the test fixture in Figure 1 of this standard in the manner shown in that figure. The clamping gasket shall be made of rubber 3 millimeters (mm) thick of hardness 50 IRHD (International Rubber Hardness Degrees), plus or minus five degrees. Movement of the test specimen, measured after the test, shall not exceed 2 mm at any point along the inside periphery of the fixture. Movement of the test specimen beyond the 2 mm limit shall be considered an incomplete test, not a test failure. A specimen used in such an incomplete test shall not be retested.

(2) At the option of the manufacturer, glass-plastic glazing specimens tested in accordance with Tests Nos. 9 and 12 may be tested unclamped. Such specimens shall be tested using the fixture in Figure 1 of the standard, including the upper frame (unclamped) which holds the specimen in place.

S5.1.2.10 Cleaning Instructions. (a) Each manufacturer of glazing materials designed to meet the requirements of S5.1.2.1., S5.1.2.2., S5.1.2.3,

S5.1.2.4, S5.1.2.5, S5.1.2.6, S5.1.2.7, S5.1.2.8, or S5.1.2.11 shall affix a label, removable by hand without tools, to each item of glazing materials. The label shall identify the product involved, specify instructions and agents for cleaning the material that will minimize the loss of transparency, and instructions for removing frost and ice, and, at the option of the manufacturer, refer owners to the vehicle's Owners Manual for more specific cleaning and other instructions.

(b) Each manufacturer of glazing materials designed to meet the requirements of paragraphs S5.1.2.4, S5.1.2.5, S5.1.2.6, S5.1.2.7, or S5.1.2.8 may permanently and indelibly mark the lower center of each item of such glazing material, in letters not less than 4.5 millimeters nor more than 6 millimeters high, the following words, GLASS PLASTIC MATERIAL—SEE OWNER'S MANUAL FOR CARE INSTRUCTIONS.

S5.1.2.11 Test Procedures for Item 4A—Rigid Plastic for Use in Side Windows Rearward of the C" Pillar. (a) Glazing materials that comply with Tests Nos. 2, 10, 13, 16, 17, as that test is modified in S5.1.2.9(c) (on the interior side only), 17, as that test is modified in paragraph (b) of this section (on the exterior side only), 19, 20, 21, and 24 of ANS Z26.1, may be used in the following specific locations:

(1) All areas in which item 4 safety glazing may be used.

(2) Any side window that meets the criteria in S5.1.2.11(a)(2)(i) and (ii):

(i) Is in a vehicle whose rearmost designated seating position is forward-facing and cannot be adjusted so that it is side or rear-facing; and

(ii) The forwardmost point on its visible interior surface is rearward of the vertical transverse plane that passes through the shoulder reference point (as described in Figure 1 of Section 571.210 Seat belt assembly anchorages) of that rearmost seating position.

(b)(1) The initial maximum haze level shall not exceed 1.0 percent. The specimens are subjected to abrasion for 100 cycles and then carefully wiped with dry lens paper (or its equivalent). The light scattered by the abraded track is measured in accordance with Test 17. The arithmetic mean of the percentages of light scattered by the three

specimens shall not exceed 4.0 percent after being subjected to abrasion for 100 cycles.

(2) The specimen is remounted on the specimen holder so that it rotates substantially in a plane and subjected to abrasion for an additional 400 cycles on the same track already abraded for 100 cycles. Specimens are carefully wiped after abrasion with dry lens paper (or its equivalent). The light scattered by the abraded track is then measured as specified in Test 17. The arithmetic mean of the percentages of light scattered by the three specimens shall not exceed 10.0 percent after being subjected to abrasion for 500 cycles.

S5.2 Edges. In vehicles except schoolbuses, exposed edges shall be treated in accordance with SEA Recommended Practice J673a, "Automotive Glazing," August 1967. In schoolbuses, exposed edges shall be banded.

S6. Certification and Marking.

S6.1 Each prime glazing material manufacturer, except as specified below, shall mark the glazing materials it manufactures in accordance with section 6 of ANS Z26. The materials specified in S5.1.2.1, S5.1.2.2, S5.1.2.3, S5.1.2.4, S5.1.2.5, S5.1.2.6, S5.1.2.7, S5.1.2.8, and S5.1.2.11 shall be identified by the marks "AS 11C", "AS 12", "AS 13", "AS 14", "AS 15A", "AS 15B", "AS 16A", "AS 16B", and "AS 4", respectively. A prime glazing material manufacturer is one which fabricates, laminates, or tempers the glazing material.

S6.2 Each prime glazing material manufacturer shall certify each piece of glazing material to which this standard applies that is designed as a component of any specific motor vehicle or camper, pursuant to section 114 of the National Traffic and Motor Vehicle Safety Act of 1966 (49 U.S.C. §30115), by adding to the mark required by S6.1 in letters and numerals of the size specified in section 6 of ANS Z26, the symbol "DOT" and a manufacturer's code mark, which will be assigned by NHTSA on the written request of the manufacturer.

S6.3 Each prime glazing material manufacturer shall certify each piece of glazing material to which this standard applies that is designed to be cut

**§ 571.205(a)**

into components for use in motor vehicles or items of motor vehicle equipment, pursuant to section 114 of the National Traffic and Motor Vehicle Safety Act (49 U.S.C. § 30115).

S6.4 Each manufacturer or distributor who cuts a section of glazing material to which this standard applies, for use in a motor vehicle or camper, shall mark that material in accordance with section 6 of ANS Z26.

**49 CFR Ch. V (10-1-10 Edition)**

S6.5 Each manufacturer or distributor who cuts a section of glazing material to which this standard applies, for use in a motor vehicle or camper, shall certify that his product complies with this standard in accordance with section 114 of the National Traffic and Motor Vehicle Safety Act (49 U.S.C. 30115).

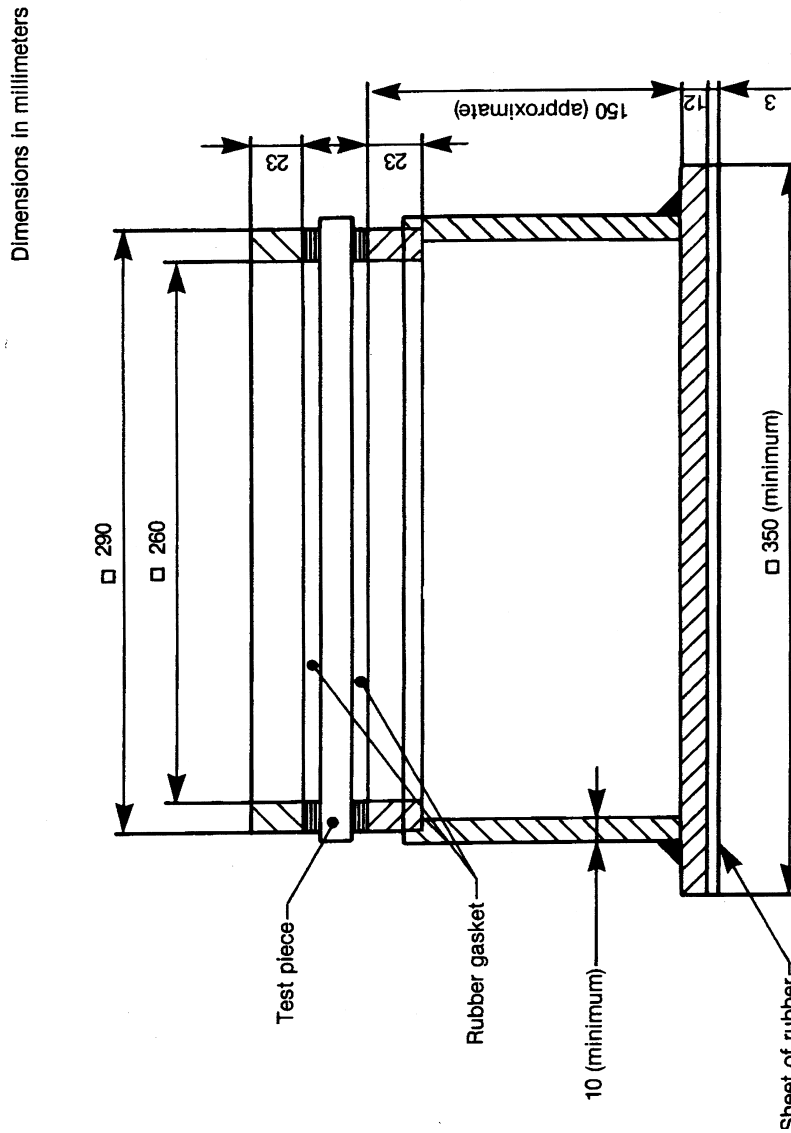

Figure 1 — Test Fixture For Clamped Specimens

[70 FR 39966, July 12, 2005]

**§571.206 Standard No. 206; Door locks and door retention components.**

S1. *Scope and Purpose.* This standard specifies requirements for vehicle door locks and door retention components, including latches, hinges, and other supporting means, to minimize the

likelihood of occupants being ejected from a vehicle as a result of impact.

S2. *Application.* This standard applies to passenger cars, multipurpose passenger vehicles, and trucks, and buses with a gross vehicle weight rating (GVWR) of 4,536 kg or less.

S3. *Definitions.*