



# Code of Federal Regulations

---

## 36

**Part 300 to End**

Revised as of July 1, 2003

### **Parks, Forests, and Public Property**

---

Containing a codification of documents  
of general applicability and future effect

As of July 1, 2003

*With Ancillaries*

Published by  
Office of the Federal Register  
National Archives and Records  
Administration

A Special Edition of the Federal Register

**U.S. GOVERNMENT PRINTING OFFICE  
WASHINGTON : 2003**

---

For sale by the Superintendent of Documents, U.S. Government Printing Office  
Internet: [bookstore.gpo.gov](http://bookstore.gpo.gov) Phone: toll free (866) 512-1800; DC area (202) 512-1800  
Fax: (202) 512-2250 Mail: Stop SSOP, Washington, DC 20402-0001

# Table of Contents

	<i>Page</i>
Explanation .....	v
Title 36:	
Chapter III—Corps of Engineers, Department of the Army .....	3
Chapter IV—American Battle Monuments Commission .....	35
Chapter V—Smithsonian Institution .....	53
Chapter VI [Reserved]	
Chapter VII—Library of Congress .....	61
Chapter VIII—Advisory Council on Historic Preservation .....	99
Chapter IX—Pennsylvania Avenue Development Corporation .....	149
Chapter X—Presidio Trust .....	215
Chapter XI—Architectural and Transportation Barriers Compliance Board .....	271
Chapter XII—National Archives and Records Administration .....	539
Chapter XV—Oklahoma City National Memorial Trust .....	853
Chapter XVI—Morris K. Udall Scholarship and Excellence in National Environmental Policy Foundation .....	857

Finding Aids:

	<i>Page</i>
Material Approved for Incorporation by Reference .....	875
Table of CFR Titles and Chapters .....	879
Alphabetical List of Agencies Appearing in the CFR .....	897
List of CFR Sections Affected .....	907



---

*Cite this Code:* CFR

*To cite the regulations in  
this volume use title,  
part and section num-  
ber. Thus, 36 CFR 312.1  
refers to title 36, part  
312, section 1.*

---

## Explanation

The Code of Federal Regulations is a codification of the general and permanent rules published in the Federal Register by the Executive departments and agencies of the Federal Government. The Code is divided into 50 titles which represent broad areas subject to Federal regulation. Each title is divided into chapters which usually bear the name of the issuing agency. Each chapter is further subdivided into parts covering specific regulatory areas.

Each volume of the Code is revised at least once each calendar year and issued on a quarterly basis approximately as follows:

Title 1 through Title 16.....	as of January 1
Title 17 through Title 27.....	as of April 1
Title 28 through Title 41.....	as of July 1
Title 42 through Title 50.....	as of October 1

The appropriate revision date is printed on the cover of each volume.

### LEGAL STATUS

The contents of the Federal Register are required to be judicially noticed (44 U.S.C. 1507). The Code of Federal Regulations is prima facie evidence of the text of the original documents (44 U.S.C. 1510).

### HOW TO USE THE CODE OF FEDERAL REGULATIONS

The Code of Federal Regulations is kept up to date by the individual issues of the Federal Register. These two publications must be used together to determine the latest version of any given rule.

To determine whether a Code volume has been amended since its revision date (in this case, July 1, 2003), consult the "List of CFR Sections Affected (LSA)," which is issued monthly, and the "Cumulative List of Parts Affected," which appears in the Reader Aids section of the daily Federal Register. These two lists will identify the Federal Register page number of the latest amendment of any given rule.

### EFFECTIVE AND EXPIRATION DATES

Each volume of the Code contains amendments published in the Federal Register since the last revision of that volume of the Code. Source citations for the regulations are referred to by volume number and page number of the Federal Register and date of publication. Publication dates and effective dates are usually not the same and care must be exercised by the user in determining the actual effective date. In instances where the effective date is beyond the cut-off date for the Code a note has been inserted to reflect the future effective date. In those instances where a regulation published in the Federal Register states a date certain for expiration, an appropriate note will be inserted following the text.

### OMB CONTROL NUMBERS

The Paperwork Reduction Act of 1980 (Pub. L. 96-511) requires Federal agencies to display an OMB control number with their information collection request.

Many agencies have begun publishing numerous OMB control numbers as amendments to existing regulations in the CFR. These OMB numbers are placed as close as possible to the applicable recordkeeping or reporting requirements.

#### OBSOLETE PROVISIONS

Provisions that become obsolete before the revision date stated on the cover of each volume are not carried. Code users may find the text of provisions in effect on a given date in the past by using the appropriate numerical list of sections affected. For the period before January 1, 2001, consult either the List of CFR Sections Affected, 1949–1963, 1964–1972, 1973–1985, or 1986–2000, published in 11 separate volumes. For the period beginning January 1, 2001, a “List of CFR Sections Affected” is published at the end of each CFR volume.

#### INCORPORATION BY REFERENCE

*What is incorporation by reference?* Incorporation by reference was established by statute and allows Federal agencies to meet the requirement to publish regulations in the Federal Register by referring to materials already published elsewhere. For an incorporation to be valid, the Director of the Federal Register must approve it. The legal effect of incorporation by reference is that the material is treated as if it were published in full in the Federal Register (5 U.S.C. 552(a)). This material, like any other properly issued regulation, has the force of law.

*What is a proper incorporation by reference?* The Director of the Federal Register will approve an incorporation by reference only when the requirements of 1 CFR part 51 are met. Some of the elements on which approval is based are:

- (a) The incorporation will substantially reduce the volume of material published in the Federal Register.
- (b) The matter incorporated is in fact available to the extent necessary to afford fairness and uniformity in the administrative process.
- (c) The incorporating document is drafted and submitted for publication in accordance with 1 CFR part 51.

Properly approved incorporations by reference in this volume are listed in the Finding Aids at the end of this volume.

*What if the material incorporated by reference cannot be found?* If you have any problem locating or obtaining a copy of material listed in the Finding Aids of this volume as an approved incorporation by reference, please contact the agency that issued the regulation containing that incorporation. If, after contacting the agency, you find the material is not available, please notify the Director of the Federal Register, National Archives and Records Administration, Washington DC 20408, or call (202) 741-6010.

#### CFR INDEXES AND TABULAR GUIDES

A subject index to the Code of Federal Regulations is contained in a separate volume, revised annually as of January 1, entitled CFR INDEX AND FINDING AIDS. This volume contains the Parallel Table of Statutory Authorities and Agency Rules (Table I). A list of CFR titles, chapters, and parts and an alphabetical list of agencies publishing in the CFR are also included in this volume.

An index to the text of “Title 3—The President” is carried within that volume.

The Federal Register Index is issued monthly in cumulative form. This index is based on a consolidation of the “Contents” entries in the daily Federal Register.

A List of CFR Sections Affected (LSA) is published monthly, keyed to the revision dates of the 50 CFR titles.

#### REPUBLICATION OF MATERIAL

There are no restrictions on the republication of material appearing in the Code of Federal Regulations.

#### INQUIRIES

For a legal interpretation or explanation of any regulation in this volume, contact the issuing agency. The issuing agency's name appears at the top of odd-numbered pages.

For inquiries concerning CFR reference assistance, call 202-741-6000 or write to the Director, Office of the Federal Register, National Archives and Records Administration, Washington, DC 20408 or e-mail [info@fedreg.nara.gov](mailto:info@fedreg.nara.gov).

#### SALES

The Government Printing Office (GPO) processes all sales and distribution of the CFR. For payment by credit card, call toll free, 866-512-1800 or DC area, 202-512-1800, M-F, 8 a.m. to 4 p.m. e.s.t. or fax your order to 202-512-2250, 24 hours a day. For payment by check, write to the Superintendent of Documents, Attn: New Orders, P.O. Box 371954, Pittsburgh, PA 15250-7954. For GPO Customer Service call 202-512-1803.

#### ELECTRONIC SERVICES

The full text of the Code of Federal Regulations, The United States Government Manual, the Federal Register, Public Laws, Public Papers, Weekly Compilation of Presidential Documents and the Privacy Act Compilation are available in electronic format at [www.access.gpo.gov/nara](http://www.access.gpo.gov/nara) ("GPO Access"). For more information, contact Electronic Information Dissemination Services, U.S. Government Printing Office. Phone 202-512-1530, or 888-293-6498 (toll-free). E-mail, [gpoaccess@gpo.gov](mailto:gpoaccess@gpo.gov).

The Office of the Federal Register also offers a free service on the National Archives and Records Administration's (NARA) World Wide Web site for public law numbers, Federal Register finding aids, and related information. Connect to NARA's web site at [www.archives.gov/federal\\_register](http://www.archives.gov/federal_register). The NARA site also contains links to GPO Access.

RAYMOND A. MOSLEY,

*Director,*

*Office of the Federal Register.*

*July 1, 2003.*

## THIS TITLE

Title 36—PARKS, FORESTS, AND PUBLIC PROPERTY is composed of three volumes. The parts in these volumes are arranged in the following order: parts 1 to 199, parts 200 to 299, and part 300 to End. The contents of these volumes represent all current regulations codified under this title of the CFR as of July 1, 2003.



# Title 36—Parks, Forests, and Public Property

(This book contains part 300 to End)

---

	<i>Part</i>
CHAPTER III—Corps of Engineers, Department of the Army ..	312
CHAPTER IV—American Battle Monuments Commission .....	400
CHAPTER V—Smithsonian Institution .....	504
CHAPTER VI [Reserved]	
CHAPTER VII—Library of Congress .....	701
CHAPTER VIII—Advisory Council on Historic Preservation ....	800
CHAPTER IX—Pennsylvania Avenue Development Corpora- tion .....	901
CHAPTER X—Presidio Trust .....	1001
CHAPTER XI—Architectural and Transportation Barriers Compliance Board .....	1120
CHAPTER XII—National Archives and Records Administra- tion .....	1200
CHAPTER XV—Oklahoma City National Memorial Trust .....	1501
CHAPTER XVI—Morris K. Udall Scholarship and Excellence in National Environmental Policy Foundation .....	1600





## CHAPTER III—CORPS OF ENGINEERS, DEPARTMENT OF THE ARMY

---

<i>Part</i>		<i>Page</i>
312	Prohibition of discriminatory practices in water resource development projects .....	5
327	Rules and regulations governing public use of water resource development projects administered by the Chief of Engineers .....	5
328	Regulation of seaplane operations at civil works water resource development projects administered by the Chief of Engineers .....	24
330	Regulation of law enforcement services contracts at civil works water resource projects administered by the Chief of Engineers .....	27
331	Regulations governing the protection, use and management of the falls of the Ohio National Wildlife Conservation Area, Kentucky and Indiana .....	30
332-399	[Reserved]	



## PART 312—PROHIBITION OF DISCRIMINATORY PRACTICES IN WATER RESOURCE DEVELOPMENT PROJECTS

Sec.

312.1 Areas covered.

312.2 Discriminatory practices prohibited.

AUTHORITY: Sec. 4, 58 Stat. 889, as amended; 16 U.S.C. 460d.

### § 312.1 Areas covered.

The regulation covered in this part shall be applicable to all water resource project lands under the supervision of the Secretary of the Army not covered in parts 311 and 326, of this title.

[29 FR 9710, July 18, 1964]

### § 312.2 Discriminatory practices prohibited.

All project land and water areas which are open to the public shall be available for use and enjoyment by the public without regard to race, creed, color or national origin. Each lessee or licensee of a project area under lease or license providing for a public or quasi-public use, including group camp activities, and each concessionaire of a lessee or licensee providing a service to the public including facilities and accommodations, shall not discriminate against any person or persons because of race, creed, color or national origin in the conduct of its operations under the lease, license or concession agreement.

[29 FR 9710, July 18, 1964]

## PART 327—RULES AND REGULATIONS GOVERNING PUBLIC USE OF WATER RESOURCE DEVELOPMENT PROJECTS ADMINISTERED BY THE CHIEF OF ENGINEERS

Sec.

327.0 Applicability.

327.1 Policy.

327.2 Vehicles.

327.3 Vessels.

327.4 Aircraft.

327.5 Swimming.

327.6 Picnicking.

327.7 Camping.

327.8 Hunting, fishing, and trapping.

327.9 Sanitation.

327.10 Fires.

327.11 Control of animals.

327.12 Restrictions.

327.13 Explosives, firearms, other weapons and fireworks.

327.14 Public property.

327.15 Abandonment and impoundment of personal property.

327.16 Lost and found articles.

327.17 Advertisement.

327.18 Commercial activities.

327.19 Permits.

327.20 Unauthorized structures.

327.21 Special events.

327.22 Unauthorized occupation.

327.23 Recreation use fees.

327.24 Interference with Government employees.

327.25 Violations of rules and regulations.

327.26 State and local laws.

327.27–327.29 [Reserved]

327.30 Shoreline Management on Civil Works Projects.

327.31 Shoreline management fee schedule.

AUTHORITY: 16 U.S.C. 460d; 16 U.S.C. 4601–6a; Sec. 210, Pub. L. 90–483, 82 Stat. 746.; 33 U.S.C. 1, 28 Stat. 362.

SOURCE: 50 FR 35556, Sept. 3, 1985, unless otherwise noted.

### § 327.0 Applicability.

The regulations covered in this part 327 shall be applicable to water resources development projects, completed or under construction, administered by the Chief of Engineers, and to those portions of jointly administered water resources development projects which are under the administrative jurisdiction of the Chief of Engineers. All other Federal, state and local laws and regulations remain in full force and effect where applicable to those water resources development projects.

[65 FR 6898, Feb. 11, 2000]

### § 327.1 Policy.

(a) It is the policy of the Secretary of the Army, acting through the Chief of Engineers, to manage the natural, cultural and developed resources of each project in the public interest, providing the public with safe and healthful recreational opportunities while protecting and enhancing these resources.

(b) Unless otherwise indicated in this part, the term “District Commander” shall include the authorized representatives of the District Commander.

(c) The term “project” or “water resources development project” refers to

## § 327.2

the water areas of any water resources development project administered by the Chief of Engineers, without regard to ownership of underlying land, to all lands owned in fee by the Federal Government and to all facilities therein or thereon of any such water resources development project.

(d) All water resources development projects open for public use shall be available to the public without regard to sex, race, color, creed, age, nationality or place of origin. No lessee, licensee, or concessionaire providing a service to the public shall discriminate against any person because of sex, race, creed, color, age, nationality or place of origin in the conduct of the operations under the lease, license or concession contract.

(e) In addition to the regulations in this part 327, all applicable Federal, state and local laws and regulations remain in full force and effect on project lands or waters which are outgranted by the District Commander by lease, license or other written agreement.

(f) The regulations in this part 327 shall be deemed to apply to those lands and waters which are subject to treaties and Federal laws and regulations concerning the rights of Indian Nations and which lands and waters are incorporated, in whole or in part, within water resources development projects administered by the Chief of Engineers, to the extent that the regulations in this part 327 are not inconsistent with such treaties and Federal laws and regulations.

(g) Any violation of any section of this part 327 shall constitute a separate violation for each calendar day in which it occurs.

(h) For the purposes of this part 327, the operator of any vehicle, vessel or aircraft as described in this part, shall be presumed to be responsible for its use on project property. In the event where an operator cannot be determined, the owner of the vehicle, vessel, or aircraft, whether attended or unattended, will be presumed responsible. Unless proven otherwise, such presumption will be sufficient to issue a citation for the violation of regulations applicable to the use of such vehicle, vessel or aircraft as provided for in § 327.25.

## 36 CFR Ch. III (7-1-03 Edition)

(i) For the purposes of this part 327, the registered user of a campsite, picnic area, or other facility shall be presumed to be responsible for its use. Unless proven otherwise, such presumption will be sufficient to issue a citation for the violation of regulations applicable to the use of such facilities as provided for in § 327.25.

[65 FR 6898, Feb. 11, 2000]

### § 327.2 Vehicles.

(a) This section pertains to all vehicles, including, but not limited to, automobiles, trucks, motorcycles, mini-bikes, snowmobiles, dune buggies, all-terrain vehicles, and trailers, campers, bicycles, or any other such equipment.

(b) Vehicles shall not be parked in violation of posted restrictions and regulations, or in such a manner as to obstruct or impede normal or emergency traffic movement or the parking of other vehicles, create a safety hazard, or endanger any person, property or environmental feature. Vehicles so parked are subject to removal and impoundment at the owner's expense.

(c) The operation and/or parking of a vehicle off authorized roadways is prohibited except at locations and times designated by the District Commander. Taking any vehicle through, around or beyond a restrictive sign, recognizable barricade, fence, or traffic control barrier is prohibited.

(d) Vehicles shall be operated in accordance with posted restrictions and regulations.

(e) No person shall operate any vehicle in a careless, negligent or reckless manner so as to endanger any person, property or environmental feature.

(f) At designated recreation areas, vehicles shall be used only to enter or leave the area or individual sites or facilities unless otherwise posted.

(g) Except as authorized by the District Commander, no person shall operate any motorized vehicle without a proper and effective exhaust muffler as defined by state and local laws, or with an exhaust muffler cutout open, or in any other manner which renders the exhaust muffler ineffective in muffling the sound of engine exhaust.

(h) Vehicles shall be operated in accordance with applicable Federal, state

and local laws, which shall be regulated by authorized enforcement officials as prescribed in § 327.26.

[65 FR 6899, Feb. 11, 2000]

**§ 327.3 Vessels.**

(a) This section pertains to all vessels or watercraft, including, but not limited to, powerboats, cruisers, houseboats, sailboats, rowboats, canoes, kayaks, personal watercraft, and any other such equipment capable of navigation on water or ice, whether in motion or at rest.

(b) The placement and/or operation of any vessel or watercraft for a fee or profit upon project waters or lands is prohibited except as authorized by permit, lease, license, or concession contract with the Department of the Army. This paragraph shall not apply to the operation of commercial tows or passenger carrying vessels not based at a Corps project which utilize project waters as a link in continuous transit over navigable waters of the United States.

(c) Vessels or other watercraft may be operated on the project waters, except in prohibited or restricted areas, in accordance with posted regulations and restrictions, including buoys. All vessels or watercraft so required by applicable Federal, state and local laws shall display an appropriate registration on board whenever the vessel is on project waters.

(d) No person shall operate any vessel or other watercraft in a careless, negligent, or reckless manner so as to endanger any person, property, or environmental feature.

(e) All vessels, when on project waters, shall have safety equipment, including personal flotation devices, on board in compliance with U.S. Coast Guard boating safety requirements and in compliance with boating safety laws issued and enforced by the state in which the vessel is located. Owners or operators of vessels not in compliance with this section may be requested to remove the vessel immediately from project waters until such time as items of non-compliance are corrected.

(f) Unless otherwise permitted by Federal, state or local law, vessels or other watercraft, while moored in commercial facilities, community or cor-

porate docks, or at any fixed or permanent mooring point, may only be used for overnight occupancy when such use is incidental to recreational boating. Vessels or other watercraft are not to be used as a place of habitation or residence.

(g) Water skis, parasails, ski-kites and similar devices are permitted in nonrestricted areas except that they may not be used in a careless, negligent, or reckless manner so as to endanger any person, property or environmental feature.

(h) Vessels shall not be attached or anchored to structures such as locks, dams, buoys or other structures unless authorized by the District Commander. All vessels when not in actual use shall be removed from project lands and waters unless securely moored or stored at designated areas approved by the District Commander. The placing of floating or stationary mooring facilities on, adjacent to, or interfering with a buoy, channel marker or other navigational aid is prohibited.

(i) The use at a project of any vessel not constructed or maintained in compliance with the standards and requirements established by the Federal Safe Boating Act of 1971 (Pub. L. 92-75, 85 Stat. 213), or promulgated pursuant to such act, is prohibited.

(j) Except as authorized by the District Commander, no person shall operate any vessel or watercraft without a proper and effective exhaust muffler as defined by state and local laws, or with an exhaust muffler cutout open, or in any other manner which renders the exhaust muffler ineffective in muffling the sound of engine exhaust.

(k) All vessels or other watercraft shall be operated in accordance with applicable Federal, state and local laws, which shall be regulated by authorized enforcement officials as prescribed in § 327.26.

[65 FR 6899, Feb. 11, 2000]

**§ 327.4 Aircraft.**

(a) This section pertains to all aircraft including, but not limited to, airplanes, seaplanes, helicopters, ultralight aircraft, motorized hang gliders, hot air balloons, any non-powered flight devices or any other such equipment.

**§ 327.5**

**36 CFR Ch. III (7-1-03 Edition)**

(b) The operation of aircraft on project lands at locations other than those designated by the District Commander is prohibited. This provision shall not be applicable to aircraft engaged on official business of Federal, state or local governments or law enforcement agencies, aircraft used in emergency rescue in accordance with the directions of the District Commander or aircraft forced to land due to circumstances beyond the control of the operator.

(c) No person shall operate any aircraft while on or above project waters or project lands in a careless, negligent or reckless manner so as to endanger any person, property or environmental feature.

(d) Nothing in this section bestows authority to deviate from rules and regulations or prescribed standards of the appropriate State Aeronautical Agency, or the Federal Aviation Administration, including, but not limited to, regulations and standards concerning pilot certifications or ratings, and airspace requirements.

(e) Except in extreme emergencies threatening human life or serious property loss, the air delivery or retrieval of any person, material or equipment by parachute, balloon, helicopter or other means onto or from project lands or waters without written permission of the District Commander is prohibited.

(f) In addition to the provisions in paragraphs (a) through (e) of this section, seaplanes are subject to the following restrictions:

(1) Such use is limited to aircraft utilized for water landings and takeoff, in this part called seaplanes, at the risk of owner, operator and passenger(s).

(2) Seaplane operations contrary to the prohibitions or restrictions established by the District Commander (pursuant to part 328 of this title) are prohibited. The responsibility to ascertain whether seaplane operations are prohibited or restricted is incumbent upon the person(s) contemplating the use of, or using, such waters.

(3) All operations of seaplanes while upon project waters shall be in accordance with U.S. Coast Guard navigation rules for powerboats or vessels and § 327.3.

(4) Seaplanes on project waters and lands in excess of 24 hours shall be securely moored at mooring facilities and at locations permitted by the District Commander. Seaplanes may be temporarily moored on project waters and lands, except in areas prohibited by the District Commander, for periods less than 24 hours providing:

(i) The mooring is safe, secure, and accomplished so as not to damage the rights of the Government or members of the public, and

(ii) The operator remains in the vicinity of the seaplane and reasonably available to relocate the seaplane if necessary.

(5) Commercial operation of seaplanes from project waters is prohibited without written approval of the District Commander following consultation with and necessary clearance from the Federal Aviation Administration (FAA) and other appropriate public authorities and affected interests.

(6) Seaplanes may not be operated at Corps projects between sunset and sunrise unless approved by the District Commander.

[65 FR 6899, Feb. 11, 2000]

**§ 327.5 Swimming.**

(a) Swimming, wading, snorkeling or scuba diving at one's own risk is permitted, except at launching sites, designated mooring points and public docks, or other areas so designated by the District Commander.

(b) An international diver down, or inland diving flag must be displayed during underwater activities.

(c) Diving, jumping or swinging from trees, bridges or other structures which cross or are adjacent to project waters is prohibited.

[65 FR 6900, Feb. 11, 2000]

**§ 327.6 Picnicking.**

Picnicking and related day-use activities are permitted, except in those areas where prohibited by the District Commander.

[65 FR 6900, Feb. 11, 2000]

**§ 327.7 Camping.**

(a) Camping is permitted only at sites and/or areas designated by the District Commander.

(b) Camping at one or more campsites at any one water resource project for a period longer than 14 days during any 30-consecutive-day period is prohibited without the written permission of the District Commander.

(c) The unauthorized placement of camping equipment or other items on a campsite and/or personal appearance at a campsite without daily occupancy for the purpose of reserving that campsite for future occupancy is prohibited.

(d) The digging or leveling of any ground or the construction of any structure without written permission of the District Commander is prohibited.

(e) Occupying or placement of any camping equipment at a campsite which is posted or otherwise marked or indicated as "reserved" without an authorized reservation for that site is prohibited.

[65 FR 6900, Feb. 11, 2000]

**§ 327.8 Hunting, fishing, and trapping.**

(a) Hunting is permitted except in areas and during periods where prohibited by the District Commander.

(b) Trapping is permitted except in areas and during periods where prohibited by the District Commander.

(c) Fishing is permitted except in swimming areas, on boat ramps or other areas designated by the District Commander.

(d) Additional restrictions pertaining to these activities may be established by the District Commander.

(e) All applicable Federal, State and local laws regulating these activities apply on project lands and waters, and shall be regulated by authorized enforcement officials as prescribed in § 327.26.

[65 FR 6900, Feb. 11, 2000]

**§ 327.9 Sanitation.**

(a) Garbage, trash, rubbish, litter, gray water, or any other waste material or waste liquid generated on the project and incidental to authorized recreational activities shall be either removed from the project or deposited in receptacles provided for that purpose. The improper disposal of such wastes, human and animal waste included, on the project is prohibited.

(b) It is a violation to bring onto a project any household or commercial garbage, trash, rubbish, debris, dead animals or litter of any kind for disposal or dumping without the written permission of the District Commander.

For the purposes of this section, the owner of any garbage, trash, rubbish, debris, dead animals or litter of any kind shall be presumed to be responsible for proper disposal. Such presumption will be sufficient to issue a citation for violation.

(c) The spilling, pumping, discharge or disposal of contaminants, pollutants or other wastes, including, but not limited to, human or animal waste, petroleum, industrial and commercial products and by-products, on project lands or into project waters is prohibited.

(d) Campers, picnickers, and all other persons using a water resources development project shall keep their sites free of trash and litter during the period of occupancy and shall remove all personal equipment and clean their sites upon departure.

(e) The discharge or placing of sewage, galley waste, garbage, refuse, or pollutants into the project waters from any vessel or watercraft is prohibited.

[65 FR 6900, Feb. 11, 2000]

**§ 327.10 Fires.**

(a) Gasoline and other fuels, except that which is contained in storage tanks of vehicles, vessels, camping equipment, or hand portable containers designed for such purpose, shall not be carried onto or stored on the project without written permission of the District Commander.

(b) Fires shall be confined to those areas designated by the District Commander, and shall be contained in fireplaces, grills, or other facilities designated for this purpose. Fires shall not be left unattended and must be completely extinguished prior to departure. The burning of materials that produce toxic fumes, including, but not limited to, tires, plastic and other floatation materials or treated wood products is prohibited. The District Commander may prohibit open burning of any type for environmental considerations.

**§ 327.11**

(c) Improper disposal of lighted smoking materials, matches or other burning material is prohibited.

[65 FR 6900, Feb. 11, 2000]

**§ 327.11 Control of animals.**

(a) No person shall bring or allow dogs, cats, or other pets into developed recreation areas or adjacent waters unless penned, caged, on a leash under six feet in length, or otherwise physically restrained. No person shall allow animals to impede or restrict otherwise full and free use of project lands and waters by the public. No person shall allow animals to bark or emit other noise which unreasonably disturbs other people. Animals and pets, except properly trained animals assisting those with disabilities (such as seeing-eye dogs), are prohibited in sanitary facilities, playgrounds, swimming beaches and any other areas so designated by the District Commander. Abandonment of any animal on project lands or waters is prohibited. Unclaimed or unattended animals are subject to immediate impoundment and removal in accordance with state and local laws.

(b) Persons bringing or allowing pets in designated public use areas shall be responsible for proper removal and disposal of any waste produced by these animals.

(c) No person shall bring or allow horses, cattle, or other livestock in camping, picnicking, swimming or other recreation areas or on trails except in areas designated by the District Commander.

(d) Ranging, grazing, watering or allowing livestock on project lands and waters is prohibited except when authorized by lease, license or other written agreement with the District Commander.

(e) Unauthorized livestock are subject to impoundment and removal in accordance with Federal, state and local laws.

(f) Any animal impounded under the provisions of this section may be confined at a location designated by the District Commander, who may assess a reasonable impoundment fee. This fee shall be paid before the impounded animal is returned to its owner(s).

(g) Wild or exotic pets and animals (including but not limited to cougars,

**36 CFR Ch. III (7-1-03 Edition)**

lions, bears, bobcats, wolves, and snakes), or any pets or animals displaying vicious or aggressive behavior or otherwise posing a threat to public safety or deemed a public nuisance, are prohibited from project lands and waters unless authorized by the District Commander, and are subject to removal in accordance with Federal, state and local laws.

[65 FR 6901, Feb. 11, 2000]

**§ 327.12 Restrictions.**

(a) The District Commander may establish and post a schedule of visiting hours and/or restrictions on the public use of a project or portion of a project. The District Commander may close or restrict the use of a project or portion of a project when necessitated by reason of public health, public safety, maintenance, resource protection or other reasons in the public interest. Entering or using a project in a manner which is contrary to the schedule of visiting hours, closures or restrictions is prohibited.

(b) Quiet shall be maintained in all public use areas between the hours of 10 p.m. and 6 a.m., or those hours designated by the District Commander. Excessive noise during such times which unreasonably disturbs persons is prohibited.

(c) Any act or conduct by any person which interferes with, impedes or disrupts the use of the project or impairs the safety of any person is prohibited. Individuals who are boisterous, rowdy, disorderly, or otherwise disturb the peace on project lands or waters may be requested to leave the project.

(d) The operation or use of any sound producing or motorized equipment, including but not limited to generators, vessels or vehicles, in such a manner as to unreasonably annoy or endanger persons at any time or exceed state or local laws governing noise levels from motorized equipment is prohibited.

(e) The possession and/or consumption of alcoholic beverages on any portion of the project land or waters, or the entire project, may be prohibited when designated and posted by the District Commander.

(f) Unless authorized by the District Commander, smoking is prohibited in



## Corps of Engineers, Army, DoD

## § 327.15

Visitor Centers, enclosed park buildings and in areas posted to restrict smoking.

[65 FR 6901, Feb. 11, 2000]

### § 327.13 Explosives, firearms, other weapons and fireworks.

(a) The possession of loaded firearms, ammunition, loaded projectile firing devices, bows and arrows, crossbows, or other weapons is prohibited unless:

(1) In the possession of a Federal, state or local law enforcement officer;

(2) Being used for hunting or fishing as permitted under §327.8, with devices being unloaded when transported to, from or between hunting and fishing sites;

(3) Being used at authorized shooting ranges; or

(4) Written permission has been received from the District Commander.

(b) Possession of explosives or explosive devices of any kind, including fireworks or other pyrotechnics, is prohibited unless written permission has been received from the District Commander.

[65 FR 6901, Feb. 11, 2000]

### § 327.14 Public property.

(a) Destruction, injury, defacement, removal or any alteration of public property including, but not limited to, developed facilities, natural formations, mineral deposits, historical and archaeological features, paleontological resources, boundary monumentation or markers and vegetative growth, is prohibited except when in accordance with written permission of the District Commander.

(b) Cutting or gathering of trees or parts of trees and/or the removal of wood from project lands is prohibited without written permission of the District Commander.

(c) Gathering of dead wood on the ground for use in designated recreation areas as firewood is permitted, unless prohibited and posted by the District Commander.

(d) The use of metal detectors is permitted on designated beaches or other previously disturbed areas unless prohibited by the District Commander for reasons of protection of archaeological, historical or paleontological resources. Specific information regarding metal

detector policy and designated use areas is available at the Manager's Office. Items found must be handled in accordance with §§327.15 and 327.16 except for non-identifiable items such as coins of value less than \$25.

[65 FR 6901, Feb. 11, 2000]

### § 327.15 Abandonment and impoundment of personal property.

(a) Personal property of any kind shall not be abandoned, stored or left unattended upon project lands or waters. After a period of 24 hours, or at any time after a posted closure hour in a public use area or for the purpose of providing public safety or resource protection, unattended personal property shall be presumed to be abandoned and may be impounded and stored at a storage point designated by the District Commander, who may assess a reasonable impoundment fee. Such fee shall be paid before the impounded property is returned to its owner.

(b) Personal property placed on Federal lands or waters adjacent to a private residence, facility and/or developments of any private nature for more than 24 hours without permission of the District Commander shall be presumed to have been abandoned and, unless proven otherwise, such presumption will be sufficient to impound the property and/or issue a citation as provided for in §327.25.

(c) The District Commander shall, by public or private sale or otherwise, dispose of all lost, abandoned or unclaimed personal property that comes into Government custody or control. However, property may not be disposed of until diligent effort has been made to find the owner, heirs, next of kin or legal representative(s). If the owner, heirs, next of kin or legal representative(s) are determined but not found, the property may not be disposed of until the expiration of 120 days after the date when notice, giving the time and place of the intended sale or other disposition, has been sent by certified or registered mail to that person at the last known address. When diligent efforts to determine the owner, heirs, next of kin or legal representative(s) are unsuccessful, the property may be disposed of without delay except that if it has a fair market value of \$100 or

**§ 327.16**

more the property may not be disposed of until 90 days after the date it is received at the storage point designated by the District Commander. The net proceeds from the sale of property shall be conveyed into the Treasury of the United States as miscellaneous receipts.

[65 FR 6901, Feb. 11, 2000]

**§ 327.16 Lost and found articles.**

All articles found shall be deposited by the finder at the Manager's office or with a ranger. All such articles shall be disposed of in accordance with the procedures set forth in § 327.15.

[65 FR 6902, Feb. 11, 2000]

**§ 327.17 Advertisement.**

(a) Advertising and the distribution of printed matter is allowed within project land and waters provided that a permit to do so has been issued by the District Commander and provided that this activity is not solely commercial advertising.

(b) An application for such a permit shall set forth the name of the applicant, the name of the organization (if any), the date, time, duration, and location of the proposed advertising or the distribution of printed matter, the number of participants, and any other information required by the permit application form. Permit conditions and procedures are available from the District Commander.

(c) Vessels and vehicles with semipermanent or permanent painted or installed signs are exempt as long as they are used for authorized recreational activities and comply with all other rules and regulations pertaining to vessels and vehicles.

(d) The District Commander shall, without unreasonable delay, issue a permit on proper application unless:

(1) A prior application for a permit for the same time and location has been made that has been or will be granted and the activities authorized by that permit do not reasonably allow multiple occupancy of the particular area; or

(2) It reasonably appears that the advertising or the distribution of printed matter will present a clear and present

**36 CFR Ch. III (7-1-03 Edition)**

danger to the public health and safety; or

(3) The number of persons engaged in the advertising or the distribution of printed matter exceeds the number that can reasonably be accommodated in the particular location applied for, considering such things as damage to project resources or facilities, impairment of a protected area's atmosphere of peace and tranquility, interference with program activities, or impairment of public use facilities; or

(4) The location applied for has not been designated as available for the advertising or the distribution of printed matter; or

(5) The activity would constitute a violation of an applicable law or regulation.

(e) If a permit is denied, the applicant shall be so informed in writing, with the reason(s) for the denial set forth.

(f) The District Commander shall designate on a map, which shall be available for inspection in the applicable project office, the locations within the project that are available for the advertising or the distribution of printed matter. Locations may be designated as not available only if the advertising or the distribution of printed matter would:

(1) Cause injury or damage to project resources; or

(2) Unreasonably impair the atmosphere of the peace and tranquility maintained in natural, historic, or commemorative zones; or

(3) Unreasonably interfere with interpretive, visitor service, or other program activities, or with the administrative activities of the Corps of Engineers; or

(4) Substantially impair the operation of public use facilities or services of Corps of Engineers concessioners or contractors.

(5) Present a clear and present danger to the public health and safety.

(g) The permit may contain such conditions as are reasonably consistent with protection and use of the project area for the purposes for which it is established.

(h) No permit shall be issued for a period in excess of 14 consecutive days, provided that permits may be extended

for like periods, upon a new application, unless another applicant has requested use of the same location and multiple occupancy of that location is not reasonably possible.

(i) It is prohibited for persons engaged in the activity under this section to obstruct or impede pedestrians or vehicles, harass project visitors with physical contact or persistent demands, misrepresent the purposes or affiliations of those engaged in the advertising or the distribution of printed matter, or misrepresent whether the printed matter is available without cost or donation.

(j) A permit may be revoked under any of those conditions, as listed in paragraph (d) of this section, that constitute grounds for denial of a permit, or for violation of the terms and conditions of the permit. Such a revocation shall be made in writing, with the reason(s) for revocation clearly set forth, except under emergency circumstances, when an immediate verbal revocation or suspension may be made, to be followed by written confirmation within 72 hours.

(k) Violation of the terms and conditions of a permit issued in accordance with this section may result in the suspension or revocation of the permit.

[65 FR 26137, May 5, 2000]

#### § 327.18 Commercial activities.

(a) The engaging in or solicitation of business on project land or waters without the express written permission of the District Commander is prohibited.

(b) It shall be a violation of this part to refuse to or fail to comply with any terms, clauses or conditions of any lease, license or agreements issued by the District Commander.

[65 FR 6902, Feb. 11, 2000]

#### § 327.19 Permits.

(a) It shall be a violation of this part to refuse to or fail to comply with the fee requirements or other terms or conditions of any permit issued under the provisions of this part 327.

(b) Permits for floating structures (issued under the authority of § 327.30) of any kind on/in waters of water resources development projects, whether

or not such waters are deemed navigable waters of the United States but where such waters are under the management of the Corps of Engineers, shall be issued at the discretion of the District Commander under the authority of this section. District Commanders will delineate those portions of the navigable waters of the United States where this provision is applicable and post notices of this designation in the vicinity of the appropriate Manager's office.

(c) Permits for non-floating structures (issued under the authority of § 327.30) of any kind constructed, placed in or affecting waters of water resources development projects where such waters are deemed navigable waters of the U.S. shall be issued under the provisions of section 10 of the Rivers and Harbors Act approved March 3, 1899 (33 U.S.C. 403). If a discharge of dredged or fill material in these waters is involved, a permit is required under section 404 of the Clean Water Act (33 U.S.C. 1344). (See 33 CFR parts 320 through 330.)

(d) Permits for non-floating structures (issued under the authority of § 327.30) of any kind in waters of water resources development projects, where such waters are under the management of the Corps of Engineers and where such waters are not deemed navigable waters of the United States, shall be issued as set forth in paragraph (b) of this section. If a discharge of dredged or fill material into any water of the United States is involved, a permit is required under section 404 of the Clean Water Act (33 U.S.C. 1344) (See 33 CFR parts 320 through 330). Water quality certification may be required pursuant to Section 401 of the Clean Water Act (33 U.S.C. 1341).

(e) Shoreline Use Permits to authorize private shoreline use facilities, activities or development (issued under the authority of § 327.30) may be issued in accordance with the project Shoreline Management Plan. Failure to comply with the permit conditions issued under § 327.30 is prohibited.

[65 FR 6902, Feb. 11, 2000]

#### § 327.20 Unauthorized structures.

The construction, placement, or existence of any structure (including, but

### § 327.21

not limited to, roads, trails, signs, non-portable hunting stands or blinds, buoys, docks, or landscape features) of any kind under, upon, in or over the project lands, or waters is prohibited unless a permit, lease, license or other appropriate written authorization has been issued by the District Commander. The design, construction, placement, existence or use of structures in violation of the terms of the permit, lease, license, or other written authorization is prohibited. The government shall not be liable for the loss of, or damage to, any private structures, whether authorized or not, placed on project lands or waters. Unauthorized structures are subject to summary removal or impoundment by the District Commander. Portable hunting stands, climbing devices, steps, or blinds, that are not nailed or screwed into trees and are removed at the end of a day's hunt may be used.

[65 FR 6902, Feb. 11, 2000]

### § 327.21 Special events.

(a) Special events including, but not limited to, water carnivals, boat regattas, fishing tournaments, music festivals, dramatic presentations or other special recreation programs are prohibited unless written permission has been granted by the District Commander. Where appropriate, District Commanders can provide the state a blanket letter of permission to permit fishing tournaments while coordinating the scheduling and details of tournaments with individual projects. An appropriate fee may be charged under the authority of § 327.23.

(b) The public shall not be charged any fee by the sponsor of such event unless the District Commander has approved in writing (and the sponsor has properly posted) the proposed schedule of fees. The District Commander shall have authority to revoke permission, require removal of any equipment, and require restoration of an area to prevent condition, upon failure of the sponsor to comply with terms and conditions of the permit/permission or the regulations in this part 327.

[65 FR 6902, Feb. 11, 2000]

### 36 CFR Ch. III (7-1-03 Edition)

### § 327.22 Unauthorized occupation.

(a) Occupying any lands, buildings, vessels or other facilities within water resource development projects for the purpose of maintaining the same as a full-or part-time residence without the written permission of the District Commander is prohibited. The provisions of this section shall not apply to the occupation of lands for the purpose of camping, in accordance with the provisions of § 327.7.

(b) Use of project lands or waters for agricultural purposes is prohibited except when in compliance with terms and conditions authorized by lease, license or other written agreement issued by the District Commander.

[65 FR 6903, Feb. 11, 2000]

### § 327.23 Recreation use fees.

(a) In accordance with the Land and Water Conservation Fund Act of 1965 (16 U.S.C. 4601) and the Omnibus Budget Reconciliation Act of 1993, Pub. L. 103-66, the Corps of Engineers collects day use fees, special recreation use fees and/or special permit fees for the use of specialized sites, facilities, equipment or services related to outdoor recreation furnished at Federal expense.

(b) Where such fees are charged, the District Commander shall insure that clear notice of fee requirements is prominently posted at each area, and at appropriate locations therein and that the notice be included in publications distributed at such areas. Failure to pay authorized recreation use fees as established pursuant to Pub. L. 88-578, 78 Stat. 897, as amended (16 U.S.C. 4601-6a), is prohibited and is punishable by a fine of not more than \$100.

(c) Failure to pay authorized day use fees, and/or properly display applicable receipt, permit or pass is prohibited.

(d) Any Golden Age or Golden Access Passport permittee shall be entitled, upon presentation of such a permit, to utilize special recreation facilities at a rate of 50 percent off the established use fee at Federally operated areas. Fraudulent use of a Golden Age or Golden Access Passport is prohibited.

[65 FR 6903, Feb. 11, 2000]

## Corps of Engineers, Army, DoD

## § 327.30

### § 327.24 Interference with Government employees.

(a) It is a Federal crime pursuant to the provisions of sections 111 and 1114 of Title 18, United States Code, to forcibly assault, resist, oppose, impede, intimidate, or interfere with, attempt to kill or kill any civilian official or employee for the U.S. Army Corps of Engineers engaged in the performance of his or her official duties, or on account of the performance of his or her official duties. Such actions or interference directed against a Federal employee while carrying out the regulations in this part are violation of such regulations and may be a state crime pursuant to the laws of the state where they occur.

(b) Failure to comply with a lawful order issued by a Federal employee acting pursuant to the regulations in this part shall be considered as interference with that employee while engaged in the performance of their official duties. Such interference with a Federal employee includes failure to provide a correct name, address or other information deemed necessary for identification upon request of the Federal employee, when that employee is authorized by the District Commander to issue citations in the performance of the employee's official duties.

[65 FR 6903, Feb. 11, 2000]

### § 327.25 Violations of rules and regulations.

(a) Any person who violates the provisions of the regulations in this part, other than for a failure to pay authorized recreation use fees as separately provided for in § 327.23, may be punished by a fine of not more than \$5,000 or imprisonment for not more than six months or both and may be tried and sentenced in accordance with the provisions of section 3401 of Title 18, United States Code. Persons designated by the District Commander shall have the authority to issue a citation for violation of the regulations in this part, requiring any person charged with the violation to appear before the United States Magistrate within whose jurisdiction the affected water re-

sources development project is located (16 U.S.C. 460d).

(b) Any person who commits an act against any official or employee of the U.S. Army Corps of Engineers that is a crime under the provisions of section 111 or section 1114 of Title 18, United States Code or under provisions of pertinent state law may be tried and sentenced as further provided under Federal or state law, as the case may be.

[65 FR 6903, Feb. 11, 2000]

### § 327.26 State and local laws.

(a) Except as otherwise provided in this part or by Federal law or regulation, state and local laws and ordinances shall apply on project lands and waters. This includes, but is not limited to, state and local laws and ordinances governing:

- (1) Operation and use of motor vehicles, vessels, and aircraft;
- (2) Hunting, fishing and trapping;
- (3) Use or possession of firearms or other weapons;
- (4) Civil disobedience and criminal acts;
- (5) Littering, sanitation and pollution; and
- (6) Alcohol or other controlled substances.

(b) These state and local laws and ordinances are enforced by those state and local enforcement agencies established and authorized for that purpose.

[65 FR 6903, Feb. 11, 2000]

### §§ 327.27-327.29 [Reserved]

### § 327.30 Shoreline Management on Civil Works Projects.

(a) *Purpose.* The purpose of this regulation is to provide policy and guidance on management of shorelines of Civil Works projects where 36 CFR part 327 is applicable.

(b) *Applicability.* This regulation is applicable to all field operating agencies with Civil Works responsibilities except when such application would result in an impingement upon existing Indian rights.

(c) *References.* (1) Section 4, 1944 Flood Control Act, as amended (16 U.S.C. 460d).

(2) The Rivers and Harbors Act of 1894, as amended and supplemented (33 U.S.C. 1)

## § 327.30

## 36 CFR Ch. III (7-1-03 Edition)

(3) Section 10, River and Harbor Act of 1899 (33 U.S.C. 403).

(4) National Historic Preservation Act of 1966 (Pub. L. 89-665; 80 Stat. 915) as amended (16 U.S.C. 470 *et seq.*).

(5) The National Environmental Policy Act of 1969 (42 U.S.C. 4321, *et seq.*).

(6) The Clean Water Act (33 U.S.C. 1344, *et seq.*).

(7) The Water Resources Development Act of 1986 (Pub. L. 99-662).

(8) Title 36, chapter III, part 327, Code of Federal Regulations, "Rules and Regulations Governing Public Use of Water Resource Development Projects Administered by the Chief of Engineers."

(9) Executive Order 12088 (13 Oct. 78).

(10) 33 CFR parts 320-330, "Regulatory Programs of the Corps of Engineers."

(11) ER 1130-2-400, "Management of Natural Resources and Outdoor Recreation at Civil Works Water Resource Projects."

(12) EM 385-1-1, "Safety and Health Requirements Manual."

(d) *Policy.* (1) It is the policy of the Chief of Engineers to protect and manage shorelines of all Civil Works water resource development projects under Corps jurisdiction in a manner which will promote the safe and healthful use of these shorelines by the public while maintaining environmental safeguards to ensure a quality resource for use by the public. The objectives of all management actions will be to achieve a balance between permitted private uses and resource protection for general public use. Public pedestrian access to and exit from these shorelines shall be preserved. For projects or portions of projects where Federal real estate interest is limited to easement title only, management actions will be appropriate within the limits of the estate acquired.

(2) Private shoreline uses may be authorized in designated areas consistent with approved use allocations specified in Shoreline Management Plans. Except to honor written commitments made prior to publication of this regulation, private shoreline uses are not allowed on water resource projects where construction was initiated after December 13, 1974, or on water resource projects where no private shoreline uses existed as of that date. Any exist-

ing permitted facilities on these projects will be grandfathered until the facilities fail to meet the criteria set forth in § 327.30(h).

(3) A Shoreline Management Plan, as described in § 327.30(e), will be prepared for each Corps project where private shoreline use is allowed. This plan will honor past written commitments. The plan will be reviewed at least once every five years and revised as necessary. Shoreline uses that do not interfere with authorized project purposes, public safety concerns, violate local norms or result in significant environmental effects should be allowed unless the public participation process identifies problems in these areas. If sufficient demand exists, consideration should be given to revising the shoreline allocations (e.g. increases/decreases). Maximum public participation will be encouraged as set forth in § 327.30(e)(6). Except to honor written commitments made prior to the publication of this regulation, shoreline management plans are not required for those projects where construction was initiated after December 13, 1974, or on projects not having private shoreline use as of that date. In that case, a statement of policy will be developed by the district commander to present the shoreline management policy. This policy statement will be subject to the approval of the division commander. For projects where two or more agencies have jurisdiction, the plan will be cooperatively prepared with the Corps as coordinator.

(4) Where commercial or other public launching and/or moorage facilities are not available within a reasonable distance, group owned mooring facilities may be allowed in Limited Development Areas to limit the proliferation of individual facilities. Generally only one permit will be necessary for a group owned mooring facility with that entity, if incorporated, or with one person from the organization designated as the permittee and responsible for all moorage spaces within the facility. No charge may be made for use of any permitted facility by others nor shall any commercial activity be engaged in thereon.

(5) The issuance of a private shoreline use permit does not convey any

real estate or personal property rights or exclusive use rights to the permit holder. The public's right of access and use of the permit area must be maintained and preserved. Owners of permitted facilities may take necessary precautions to protect their property from theft, vandalism or trespass, but may in no way preclude the public right of pedestrian or vessel access to the water surface or public land adjacent to the facility.

(6) Shoreline Use Permits will only be issued to individuals or groups with legal right of access to public lands.

(e) *Shoreline Management Plan*—

(1) *General.* The policies outlined in §327.30(d) will be implemented through preparation of Shoreline Management Plans, where private shoreline use is allowed.

(2) *Preparation.* A Shoreline Management Plan is prepared as part of the Operational Management Plan. A moratorium on accepting applications for new permits may be placed in effect from the time an announcement of creation of a plan or formal revision of a plan is made until the action is completed.

(3) *Approval.* Approval of Shoreline Management Plans rests with division commanders. After approval, one copy of each project Shoreline Management Plan will be forwarded to HQUSACE (CECW-ON) WASH DC 20314-1000. Copies of the approved plan will also be made available to the public.

(4) *Scope and Format.* The Shoreline Management Plan will consist of a map showing the shoreline allocated to the uses listed in §327.30(e)(6), related rules and regulations, a discussion of what areas are open or closed to specific activities and facilities, how to apply for permits and other information pertinent to the Corps management of the shoreline. The plan will be prepared in sufficient detail to ensure that it is clear to the public what uses are and are not allowed on the shoreline of the project and why. A process will be developed and presented in the Shoreline Management Plan that prescribes a procedure for review of activities requested but not specifically addressed by the Shoreline Management Plan.

(5) *Shoreline Allocation.* The entire shoreline will be allocated within the

classifications below and delineated on a map. Any action, within the context of this rule, which gives a special privilege to an individual or group of individuals on land or water at a Corps project, that precludes use of those lands and waters by the general public, is considered to be private shoreline use. Shoreline allocations cover that land and/or water extending from the edge of the water and waterward with the exception of allocations for the purpose of vegetation modification which extends landward to the project boundary. These allocations should complement, but certainly not contradict, the land classifications in the project master plan. A map of sufficient size and scale to clearly display the shoreline allocations will be conspicuously displayed or readily available for viewing in the project administration office and will serve as the authoritative reference. Reduced or smaller scale maps may be developed for public dissemination but the information contained on these must be identical to that contained on the display map in the project administration office. No changes will be made to these maps except through the formal update process. District commanders may add specific constraints and identify areas having unique characteristics during the plan preparation, review, or updating process in addition to the allocation classifications described below.

(i) *Limited Development Areas.* Limited Development Areas are those areas in which private facilities and/or activities may be allowed consistent with §327.30(h) and appendix A. Modification of vegetation by individuals may be allowed only following the issuance of a permit in accordance with appendix A. Potential low and high water conditions and underwater topography should be carefully evaluated before shoreline is allocated as Limited Development Area.

(ii) *Public Recreation Areas.* Public Recreation Areas are those areas designated for commercial concessionaire facilities, Federal, state or other similar public use. No private shoreline use facilities and/or activities will be permitted within or near designated or developed public recreation areas. The

term “near” depends on the terrain, road system, and other local conditions, so actual distances must be established on a case by case basis in each project Shoreline Management Plan. No modification of land forms or vegetation by private individuals or groups of individuals is permitted in public recreation areas.

(iii) *Protected Shoreline Areas.* Protected Shoreline Areas are those areas designated to maintain or restore aesthetic, fish and wildlife, cultural, or other environmental values. Shoreline may also be so designated to prevent development in areas that are subject to excessive siltation, erosion, rapid dewatering, or exposure to high wind, wave, or current action and/or in areas in which development would interfere with navigation. No Shoreline Use Permits for floating or fixed recreation facilities will be allowed in protected areas. Some modification of vegetation by private individuals, such as clearing a narrow meandering path to the water, or limited mowing, may be allowed only following the issuance of a permit if the resource manager determines that the activity will not adversely impact the environment or physical characteristics for which the area was designated as protected. In making this determination the effect on water quality will also be considered.

(iv) *Prohibited Access Areas.* Prohibited Access Areas are those in which public access is not allowed or is restricted for health, safety or security reasons. These could include hazardous areas near dams, spillways, hydro-electric power stations, work areas, water intake structures, etc. No shoreline use permits will be issued in Prohibited Access Areas.

(6) *Public Participation.* District commanders will ensure public participation to the maximum practicable extent in Shoreline Management Plan formulation, preparation and subsequent revisions. This may be accomplished by public meetings, group workshops, open houses or other public involvement techniques. When master plan updates and preparation of the Shoreline Management Plans are concurrent, public participation may be combined and should consider all as-

pects of both plans, including shoreline allocation classifications. Public participation will begin during the initial formulation stage and must be broad-based to cover all aspects of public interest. The key to successful implementation is an early and continual public relations program. Projects with significant numbers of permits should consider developing computerized programs to facilitate exchange of information with permittees and to improve program efficiency. Special care will be taken to advise citizen and conservation organizations; Federal, state and local natural resource management agencies; Indian Tribes; the media; commercial concessionaires; congressional liaisons; adjacent landowners and other concerned entities during the formulation of Shoreline Management Plans and subsequent revisions. Notices shall be published prior to public meetings to assure maximum public awareness. Public notices shall be issued by the district commander allowing for a minimum of 30 days for receipt of written public comment in regard to the proposed Shoreline Management Plan or any major revision thereto.

(7) *Periodic Review.* Shoreline Management Plans will be reviewed periodically, but no less often than every five years, by the district commander to determine the need for update. If sufficient controversy or demand exists, consideration should be given, consistent with other factors, to a process of reevaluation of the shoreline allocations and the plan. When changes to the Shoreline Management Plan are needed, the plan will be formally updated through the public participation process. Cumulative environmental impacts of permit actions and the possibility of preparing or revising project NEPA documentation will be considered. District commanders may make minor revisions to the Shoreline Management Plan when the revisions are consistent with policy and funds for a complete plan update are not available. The amount and type of public involvement needed for such revision is at the discretion of the district commander.

(f) *Instruments for Shoreline Use.* Instruments used to authorize private



shoreline use facilities, activities or development are as follows:

(1) *Shoreline Use Permits.* (i) Shoreline Use Permits are issued and enforced in accordance with provisions of 36 CFR 327.19.

(ii) Shoreline Use Permits are required for private structures/activities of any kind (except boats) in waters of Civil Works projects whether or not such waters are deemed navigable and where such waters are under the primary jurisdiction of the Secretary of the Army and under the management of the Corps of Engineers.

(iii) Shoreline Use Permits are required for non-floating structures on waters deemed commercially non-navigable, when such waters are under management of the Corps of Engineers.

(iv) Shoreline Use Permits are also required for land vegetation modification activities which do not involve disruption to land form.

(v) Permits should be issued for a term of five years. To reduce administration costs, one year permits should be issued only when the location or nature of the activity requires annual reissuance.

(vi) Shoreline Use Permits for erosion control may be issued for the life or period of continual ownership of the structure by the permittee and his/her legal spouse.

(2) *Department of the Army Permits.* Dredging, construction of fixed structures, including fills and combination fixed-floating structures and the discharge of dredged or fill material in waters of the United States will be evaluated under authority of section 10, River and Harbor Act of 1899 (33 U.S.C. 403) and section 404 of the Clean Water Act (33 U.S.C. 1344). Permits will be issued where appropriate.

(3) *Real Estate Instruments.* Commercial development activities and activities which involve grading, cuts, fills, or other changes in land form, or establishment of appropriate land-based support facilities required for private floating facilities, will continue to be covered by a lease, license or other legal grant issued through the appropriate real estate element. Shoreline Management Plans should identify the types of activities that require real estate instruments and indicate the gen-

eral process for obtaining same. Shoreline Use Permits are not required for facilities or activities covered by a real estate instrument.

(g) *Transfer of Permits.* Shoreline Use Permits are non-transferable. They become null and void upon sale or transfer of the permitted facility or the death of the permittee and his/her legal spouse.

(h) *Existing Facilities Now Under Permit.* Implementation of a Shoreline Management Plan shall consider existing permitted facilities and prior written Corps commitments implicit in their issuance. Facilities or activities permitted under special provisions should be identified in a way that will set them apart from other facilities or activities.

(1) Section 6 of Pub. L. 97-140 provides that no lawfully installed dock or appurtenant structures shall be required to be removed prior to December 31, 1989, from any Federal water resources reservoir or lake project administered by the Secretary of the Army, acting through the Chief of Engineers, on which it was located on December 29, 1981, if such property is maintained in usable condition, and does not occasion a threat to life or property.

(2) In accordance with section 1134(d) of Pub. L. 99-662, any houseboat, boat-house, floating cabin or lawfully installed dock or appurtenant structures in place under a valid shoreline use permit as of November 17, 1986, cannot be forced to be removed from any Federal water resources project or lake administered by the Secretary of the Army on or after December 31, 1989, if it meets the three conditions below except where necessary for immediate use for public purposes or higher public use or for a navigation or flood control project.

(i) Such property is maintained in a usable and safe condition,

(ii) Such property does not occasion a threat to life or property, and

(iii) The holder of the permit is in substantial compliance with the existing permit.

(3) All such floating facilities and appurtenances will be formally recognized in an appropriate Shoreline Management Plan. New permits for these

## § 327.30

permitted facilities will be issued to new owners. If the holder of the permit fails to comply with the terms of the permit, it may be revoked and the holder required to remove the structure, in accordance with the terms of the permit as to notice, time, and appeal.

(i) *Facility Maintenance.* Permitted facilities must be operated, used and maintained by the permittee in a safe, healthful condition at all times. If determined to be unsafe, the resource manager will establish together with the permittee a schedule, based on the seriousness of the safety deficiency, for correcting the deficiency or having it removed, at the permittee's expense. The applicable safety and health prescriptions in EM 385-1-1 should be used as a guide.

(j) *Density of Development.* The density of private floating and fixed recreation facilities will be established in the Shoreline Management Plan for all portions of Limited Development areas consistent with ecological and aesthetic characteristics and prior written commitments. The facility density in Limited Development Areas should, if feasible, be determined prior to the development of adjacent private property. The density of facilities will not be more than 50 per cent of the Limited Development Area in which they are located. Density will be measured by determining the linear feet of shoreline as compared to the width of the facilities in the water plus associated moorage arrangements which restrict the full unobstructed use of that portion of the shoreline. When a Limited Development Area or a portion of a Limited Development area reaches maximum density, notice should be given to the public and facility owners in that area that no additional facilities will be allowed. In all cases, sufficient open area will be maintained for safe maneuvering of watercraft. Docks should not extend out from the shore more than one-third of the width of a cove at normal recreation or multipurpose pool. In those cases where current density of development exceeds the density level established in the Shoreline Management Plan, the density will be reduced to the prescribed level through attrition.

## 36 CFR Ch. III (7-1-03 Edition)

(k) *Permit Fees.* Fees associated with the Shoreline Use Permits shall be paid prior to issuing the permit in accordance with the provisions of § 327.30(c)(1). The fee schedule will be published separately.

### APPENDIX A TO § 327.30—GUIDELINES FOR GRANTING SHORELINE USE PERMITS

#### 1. General

a. Decisions regarding permits for private floating recreation facilities will consider the operating objectives and physical characteristics of each project. In developing Shoreline Management Plans, district commanders will give consideration to the effects of added private boat storage facilities on commercial concessions for that purpose. Consistent with established policies, new commercial concessions may be alternatives to additional limited development shoreline.

b. Permits for individually or group owned shoreline use facilities may be granted only in Limited Development Areas when the sites are not near commercial marine services and such use will not despoil the shoreline nor inhibit public use or enjoyment thereof. The installation and use of such facilities will not be in conflict with the preservation of the natural characteristics of the shoreline nor will they result in significant environmental damage. Charges will be made for Shoreline Use Permits in accordance with the separately published fee schedule.

c. Permits may be granted within Limited Development Areas for ski jumps, floats, boat moorage facilities, duck blinds, and other private floating recreation facilities when they will not create a safety hazard and inhibit public use or enjoyment of project waters or shoreline. A Corps permit is not required for temporary ice fishing shelters or duck blinds when they are regulated by a state program. When the facility or activity is authorized by a shoreline use permit, a separate real estate instrument is generally not required.

d. Group owned boat mooring facilities may be permitted in Limited Development Areas where practicable (e.g. where physically feasible in terms of access, water depths, wind protection, etc.).

#### 2. Applications for Shoreline Use Permits

a. Applications for private Shoreline Use Permits will be reviewed with full consideration of the policies set forth in this and referenced regulations, and the Shoreline Management Plan. Fees associated with the Shoreline Use Permit shall be paid prior to issuing the permit. Plans and specifications of the proposed facility shall be submitted and approved prior to the start of construction. Submissions should include engineering

details, structural design, anchorage method, and construction materials; the type, size, location and ownership of the facility; expected duration of use; and an indication of willingness to abide by the applicable regulations and terms and conditions of the permit. Permit applications shall also identify and locate any land-based support facilities and any specific safety considerations.

b. Permits will be issued by the district commander or his/her authorized representative on ENG Form 4264-R (Application for Shoreline Use Permit) (appendix B). Computer generated forms may be substituted for ENG Form 4264-R provided all information is included. The computer generated form will be designated, "ENG Form 4264-R-E, Oct 87 (Electronic generation approved by USACE, Oct 87)".

c. The following are guides to issuance of Shoreline Use Permits:

(1) Use of boat mooring facilities, including piers and boat (shelters) houses, will be limited to vessel or watercraft mooring and storage of gear essential to vessel or watercraft operation.

(2) Private floating recreation facilities, including boat mooring facilities shall not be constructed or used for human habitation or in a manner which gives the appearance of converting Federal public property on which the facility is located to private, exclusive use. New docks with enclosed sides (i.e. boat-houses) are prohibited.

(3) No private floating facility will exceed the minimum size required to moor the owner's boat or boats plus the minimum size required for an enclosed storage locker of oars, life preservers and other items essential to watercraft operation. Specific size limitations may be established in the project Shoreline Management Plan.

(4) All private floating recreation facilities including boat mooring facilities will be constructed in accordance with plans and specifications, approved by the resource manager, or a written certification from a licensed engineer, stating the facility is structurally safe will accompany the initial submission of the plans and specifications.

(5) Procedures regarding permits for individual facilities shall also apply to permits for non-commercial group mooring facilities.

(6) Facilities attached to the shore shall be securely anchored by means of moorings which do not obstruct the free use of the shoreline, nor damage vegetation or other natural features. Anchoring to vegetation is prohibited.

(7) Electrical service and equipment leading to or on private mooring facilities must not pose a safety hazard nor conflict with other recreational use. Electrical installations must be weatherproof and meet all current applicable electrical codes and regulations. The facility must be equipped with quick disconnect fittings mounted above the

flood pool elevation. All electrical installations must conform to the National Electric Code and all state, and local codes and regulations. In those states where electricians are licensed, registered, or otherwise certified, a copy of the electrical certification must be provided to the resource manager before a Shoreline Use Permit can be issued or renewed. The resource manager will require immediate removal or disconnection of any electrical service or equipment that is not certified (if appropriate), does not meet code, or is not safely maintained. All new electrical lines will be installed underground. This will require a separate real estate instrument for the service right-of-way. Existing overhead lines will be allowed, as long as they meet all applicable electrical codes, regulations and above guidelines, to include compatibility and safety related to fluctuating water levels.

(8) Private floating recreation facilities will not be placed so as to interfere with any authorized project purposes, including navigation, or create a safety or health hazard.

(9) The district commander or his/her authorized representative may place special conditions on the permit when deemed necessary. Requests for waivers of shoreline management plan permit conditions based on health conditions will be reviewed on a case by case basis by the Operations Manager. Efforts will be made to reduce onerous requirements when a limiting health condition is obvious or when an applicant provides a doctor's certification of need for conditions which are not obvious.

(10) Vegetation modification, including but not limited to, cutting, pruning, chemical manipulation, removal or seeding by private individuals is allowed only in those areas designated as Limited Development Areas or Protected Shoreline Areas. An existing (as of July 1, 1987) vegetation modification permit, within a shoreline allocation which normally would not allow vegetation modification, should be grandfathered. Permittees will not create the appearance of private ownership of public lands.

(11) The term of a permit for vegetation modification will be for five years. Where possible, such permits will be consolidated with other shoreline management permits into a single permit. The district commander is authorized to issue vegetation modification permits of less than five years for one-time requests or to aid in the consolidation of shoreline management permits.

(12) When issued a permit for vegetative modification, the permittee will delineate the government property line, as surveyed and marked by the government, in a clear but unobtrusive manner approved by the district commander and in accordance with the project Shoreline Management Plan and the conditions of the permit. Other adjoining owners may also delineate the common

boundary subject to these same conditions. This delineation may include, but is not limited to, boundary plantings and fencing. The delineation will be accomplished at no cost to the government.

(13) No permit will be issued for vegetation modification in Protected Shoreline Areas until the environmental impacts of the proposed modification are assessed by the resource manager and it has been determined that no significant adverse impacts will result. The effects of the proposed modification on water quality will also be considered in making this determination.

(14) The original of the completed permit application is to be retained by the permittee. A duplicate will be retained in the resource manager's office.

*3. Permit Revocation*

Permits may be revoked by the district commander when it is determined that the public interest requires such revocation or when the permittee fails to comply with terms and conditions of the permit, the Shoreline Management Plan, or of this regulation. Permits for duck blinds and ice fishing shelters will be issued to cover a period not to exceed 30 days prior to and 30 days after the season.

*4. Removal of Facilities*

Facilities not removed when specified in the permit or when requested after termination or revocation of the permit will be treated as unauthorized structures pursuant to 36 CFR 327.20.

*5. Posting of Permit Number*

Each district will procure 5"x8" or larger printed permit tags of light metal or plastic for posting. The permit display tag shall be posted on the facility and/or on the land area covered by the permit, so that it can be visually checked, with ease in accordance with instructions provided by the resource manager. Facilities or activities permitted under special provisions should be identified in a way that will set apart from other facilities or activities.

APPENDIX B TO § 327.30—APPLICATION FOR SHORELINE USE PERMIT [RESERVED]

APPENDIX C TO § 327.30—SHORELINE USE PERMIT CONDITIONS

1. This permit is granted solely to the applicant for the purpose described on the attached permit.

2. The permittee agrees to and does hereby release and agree to save and hold the Government harmless from any and all causes of action, suits at law or equity, or claims or demands or from any liability of any nature whatsoever for or on account of any damages to persons or property, including a permitted

facility, growing out of the ownership, construction, operation or maintenance by the permittee of the permitted facilities and/or activities.

3. Ownership, construction, operation, use and maintenance of a permitted facility are subject to the Government's navigation servitude.

4. No attempt shall be made by the permittee to forbid the full and free use by the public of all public waters and/or lands at or adjacent to the permitted facility or to unreasonably interfere with any authorized project purposes, including navigation in connection with the ownership, construction, operation or maintenance of a permitted facility and/or activity.

5. The permittee agrees that if subsequent operations by the Government require an alteration in the location of a permitted facility and/or activity or if in the opinion of the district commander a permitted facility and/or activity shall cause unreasonable obstruction to navigation or that the public interest so requires, the permittee shall be required, upon written notice from the district commander to remove, alter, or relocate the permitted facility, without expense to the Government.

6. The Government shall in no case be liable for any damage or injury to a permitted facility which may be caused by or result from subsequent operations undertaken by the Government for the improvement of navigation or for other lawful purposes, and no claims or right to compensation shall accrue from any such damage. This includes any damage that may occur to private property if a facility is removed for noncompliance with the conditions of the permit.

7. Ownership, construction, operation, use and maintenance of a permitted facility and/or activity are subject to all applicable Federal, state and local laws and regulations. Failure to abide by these applicable laws and regulations may be cause for revocation of the permit.

8. This permit does not convey any property rights either in real estate or material; and does not authorize any injury to private property or invasion of private rights or any infringement of Federal, state or local laws or regulations, nor does it obviate the necessity of obtaining state or local assent required by law for the construction, operation, use or maintenance of a permitted facility and/or activity.

9. The permittee agrees to construct the facility within the time limit agreed to on the permit issuance date. The permit shall become null and void if construction is not completed within that period. Further, the permittee agrees to operate and maintain any permitted facility and/or activity in a manner so as to provide safety, minimize

any adverse impact on fish and wildlife habitat, natural, environmental, or cultural resources values and in a manner so as to minimize the degradation of water quality.

10. The permittee shall remove a permitted facility within 30 days, at his/her expense, and restore the waterway and lands to a condition accepted by the resource manager upon termination or revocation of this permit or if the permittee ceases to use, operate or maintain a permitted facility and/or activity. If the permittee fails to comply to the satisfaction of the resource manager, the district commander may remove the facility by contract or otherwise and the permittee agrees to pay all costs incurred thereof.

11. The use of a permitted boat dock facility shall be limited to the mooring of the permittee's vessel or watercraft and the storage, in enclosed locker facilities, of his/her gear essential to the operation of such vessel or watercraft.

12. Neither a permitted facility nor any houseboat, cabin cruiser, or other vessel moored thereto shall be used as a place of habitation or as a full or part-time residence or in any manner which gives the appearance of converting the public property, on which the facility is located, to private use.

13. Facilities granted under this permit will not be leased, rented, sub-let or provided to others by any means of engaging in commercial activity(s) by the permittee or his/her agent for monetary gain. This does not preclude the permittee from selling total ownership to the facility.

14. Floats and the flotation material for all docks and boat mooring buoys shall be fabricated of materials manufactured for marine use. The float and its flotation material shall be 100% warranted for a minimum of 8 years against sinking, becoming waterlogged, cracking, peeling, fragmenting, or losing beads. All floats shall resist puncture and penetration and shall not be subject to damage by animals under normal conditions for the area. All floats and the flotation material used in them shall be fire resistant. Any float which is within 40 feet of a line carrying fuel shall be 100% impervious to water and fuel. The use of new or recycled plastic or metal drums or non-compartmentalized air containers for encasement or floats is prohibited. Existing floats are authorized until it or its flotation material is no longer serviceable, at which time it shall be replaced with a float that meets the conditions listed above. For any floats installed after the effective date of this specification, repair or replacement shall be required when it or its flotation material no longer performs its designated function or it fails to meet the specifications for which it was originally warranted.

15. Permitted facilities and activities are subject to periodic inspection by authorized Corps representatives. The resource manager

will notify the permittee of any deficiencies and together establish a schedule for their correction. No deviation or changes from approved plans will be allowed without prior written approval of the resource manager.

16. Floating facilities shall be securely attached to the shore in accordance with the approved plans by means of moorings which do not obstruct general public use of the shoreline or adversely affect the natural terrain or vegetation. Anchoring to vegetation is prohibited.

17. The permit display tag shall be posted on the permitted facility and/or on the land areas covered by the permit so that it can be visually checked with ease in accordance with instructions provided by the resource manager.

18. No vegetation other than that prescribed in the permit will be damaged, destroyed or removed. No vegetation of any kind will be planted, other than that specifically prescribed in the permit.

19. No change in land form such as grading, excavation or filling is authorized by this permit.

20. This permit is non-transferable. Upon the sale or other transfer of the permitted facility or the death of the permittee and his/her legal spouse, this permit is null and void.

21. By 30 days written notice, mailed to the permittee by certified letter, the district commander may revoke this permit whenever the public interest necessitates such revocation or when the permittee fails to comply with any permit condition or term. The revocation notice shall specify the reasons for such action. If the permittee requests a hearing in writing to the district commander through the resource manager within the 30-day period, the district commander shall grant such hearing at the earliest opportunity. In no event shall the hearing date be more than 60 days from the date of the hearing request. Following the hearing, a written decision will be rendered and a copy mailed to the permittee by certified letter.

22. Notwithstanding the conditions cited in condition 21 above, if in the opinion of the district commander, emergency circumstances dictate otherwise, the district commander may summarily revoke the permit.

23. When vegetation modification on these lands is accomplished by chemical means, the program will be in accordance with appropriate Federal, state and local laws, rules and regulations.

24. The resource manager or his/her authorized representative shall be allowed to cross the permittee's property, as necessary to inspect facilities and/or activities under permit.

**§ 327.31**

25. When vegetation modification is allowed, the permittee will delineate the government property line in a clear, but unobtrusive manner approved by the resource manager and in accordance with the project Shoreline Management Plan.

26. If the ownership of a permitted facility is sold or transferred, the permittee or new owner will notify the Resource Manager of the action prior to finalization. The new owner must apply for a Shoreline Use Permit within 14 days or remove the facility and restore the use area within 30 days from the date of ownership transfer.

27. If permitted facilities are removed for storage or extensive maintenance, the resource manager may require all portions of the facility be removed from public property.

APPENDIX D TO § 327.30—PERMIT [RESERVED]

[55 FR 30697, July 27, 1990, as amended at 57 FR 21895, May 26, 1992; 57 FR 29220, July 1, 1992; 63 FR 35828, July 1, 1998]

EFFECTIVE DATE NOTE: The amendment to § 327.30 revising the last sentence of paragraph (k), published at 56 FR 29587, June 28, 1991, was deferred indefinitely. See 56 FR 49706, Oct. 1, 1991. The administrative charges contained in § 327.30, Shoreline Management on Civil Works Projects, published in the July 1, 1991 edition of the Code of Federal Regulations will remain in effect. Any future decisions affecting this regulation will be published in the FEDERAL REGISTER at a later date by the Corps of Engineers, Department of the Army. For the convenience of the user, the rule published on June 28, 1991, at FR page 29587, is set forth as follows:

**§ 327.30 Shoreline Management on Civil Works Projects.**

\* \* \* \* \*

(k) \* \* \* The Fee Schedule is published in § 327.31.

**§ 327.31 Shoreline management fee schedule.**

A charge will be made for Shoreline Use Permits to help defray expenses associated with issuance and administration of the permits. As permits become eligible for renewal after July 1, 1976, a charge of \$10 for each new permit and a \$5 annual fee for inspection of floating facilities will be made. There will be no annual inspection fee for permits for vegetative modification on Shoreline areas. In all cases the total administrative charge will be collected initially

**36 CFR Ch. III (7-1-03 Edition)**

at the time of permit issuance rather than on a piecemeal annual basis.

[56 FR 61163, Dec. 2, 1991; 56 FR 65190, Dec. 16, 1991]

**PART 328—REGULATION OF SEAPLANE OPERATIONS AT CIVIL WORKS WATER RESOURCE DEVELOPMENT PROJECTS ADMINISTERED BY THE CHIEF OF ENGINEERS**

Sec.

- 328.1 Purpose.
- 328.2 Applicability.
- 328.3 References.
- 328.4 Policy.
- 328.5 Guidelines for seaplane use of project waters.
- 328.6 Procedures.
- 328.7 Other authorities.

AUTHORITY: Sec. 4 of the Act of Dec. 22, 1944, 58 Stat. 889, as amended, (16 U.S.C. 460d).

SOURCE: 42 FR 59076, Nov. 15, 1977, unless otherwise noted.

**§ 328.1 Purpose.**

This regulation, in connection with the modification of the present prohibition of seaplane operations by the amendment to § 327.4 of title 36 of the Code of Federal Regulations, is designed to provide uniform policies and criteria for designating Corps projects, or portions thereof, at which seaplane operations are prohibited or restricted; and to continue to protect the integrity and all authorized uses of such projects and the safety of users of such projects. As used in this regulation, *projects* or *Corps projects* means water resources development projects administered by the Chief of Engineers.

**§ 328.2 Applicability.**

This regulation is applicable to all Field Operating Agencies having Civil Works responsibilities.

**§ 328.3 References.**

- (a) Title 36 CFR, part 327, Rules and Regulations Governing Public Use of Water Resource Development Projects Administered by the Chief of Engineers (38 FR 7552, March 23, 1973).
- (b) ER 1105-2-507.
- (c) ER 1130-2-400.

## Corps of Engineers, Army, DoD

## § 328.6

- (d) ER 1145-2-301.
- (e) ER 1145-2-303.
- (f) ER 1165-2-400.
- (g) ER 405-2-800 Series.

### § 328.4 Policy.

(a) The objective of Corps of Engineers resources management is to maximize public enjoyment and use of the lands, waters, forests, and associated recreational resources, consistent with their aesthetic and biological values. Such management includes efforts to preserve and enhance the environmental amenities that are the source of the recreational value associated with the project and to allow such other new and innovative uses of the projects that are not detrimental thereto.

(b) Seaplane operations at water resource development projects administered by the Chief of Engineers may involve hazards including, but not limited to, conflicting recreational activities, floating debris, and underwater hazards, which may be accentuated by the normal fluctuations of water levels.

(c) Seaplane operations may be prohibited or restricted at such water resource development projects, or portions thereof, for a variety of management reasons. Prohibiting or restricting seaplane operations in certain portions within a project in no way implies that safety hazards to seaplane operations or to other recreation users may not exist in other portions of such project.

(d) The operation of a seaplane at Corps projects is at the risk of the plane's owner, operator, and passenger(s). The responsibility to ascertain whether seaplane operations are permitted, prohibited or restricted at such projects, and portions thereof, is incumbent upon the person(s) contemplating the use of, or using, such waters.

### § 328.5 Guidelines for seaplane use of project waters.

(a) All operations of the aircraft while upon the water shall be in accordance with the marine rules of the road for power boats or vessels.

(b) Seaplanes on project waters and lands in excess of 24 hours shall be se-

curally moored at mooring facilities and at locations permitted by the District Engineer. Seaplanes may be temporarily moored on project waters and lands, except in areas prohibited by the District Engineer, for periods less than 24 hours providing that—

(1) The mooring is safe, secure, and accomplished so as not to damage the rights of the government or members of the public and

(2) The operator remains in the vicinity of the seaplane and reasonably available to relocate the seaplane if necessary.

(c) No commercial operation of seaplanes from project waters will be allowed without written approval of the District Engineer following consultation with and the necessary clearance from the Federal Aviation Administration (FAA) and other appropriate public authorities and affected interests.

(d) Seaplanes may not be operated at Corps projects between sunset and sunrise unless adequate lighting and supervision are available.

(e) Requests for public commercial facilities in support of seaplanes will be handled under normal concession policies.

(f) Permits for floating and non-floating structures of any kind, in, on, or affecting project waters, under the management of the Resource Manager, including waters under lease, license or other outgrant agreement, shall be handled in accordance with the lake-shore management plan or policy statement for the project involved, §327.19 of title 36, Code of Federal Regulations and, where required by statute or regulation, section 10 of the River and Harbor Act (approved March 3, 1899) and section 404 of the Federal Water Pollution Control Act of 1972 (Pub. L. 92-500).

(g) Appropriate signs should be employed to inform users of projects, or portions thereof, where seaplane operations are permitted.

### § 328.6 Procedures.

(a) In order to protect the integrity and all authorized uses of Corps projects and the safety of all users of the lake projects, the District Engineer shall:

(1) Examine and investigate each Corps project within his district which a seaplane operator could conceivably attempt to use for seaplane operations, and determine those projects, or portions thereof, in which seaplane operations should be prohibited.

(2) Establish such restrictions on seaplane operations as he deems necessary or desirable in accordance with these regulations for other areas. Seaplane takeoff and landing maneuvers within specified distances of the shoreline, bridges, causeways, water utility crossings, dams, and similar structures should be prohibited.

(3) Prior to concluding any such examination and investigation, consult with the FAA, appropriate State aeronautical agency, lessee or licensee of outgranted lands, the Coast Guard, and state boating law administrators, and use his best efforts to consult with other interested or affected public authorities and private interests for their guidance, particularly for those projects which are regularly used by the public for recreational purposes or are located in the vicinity of actively used airports, air fields, or densely populated areas. News releases, public notice, and congressional liaison should be used. Public hearings are encouraged.

(4) In making his investigation, examination, and determination, consider environmental factors in accordance with the National Environmental Policy Act of 1969 (NEPA), Pub. L. 91-190—particularly should he consider the impact that seaplane operations may have on the safety at the project, aquatic, fish and wildlife, noise levels, recreation, and air and water quality. Prior to concluding such investigation and examination, he shall prepare an environmental impact assessment (EIA) and, if necessary, an environmental impact statement (EIS) assessing the environmental impacts of permitting seaplanes to operate at the projects, or portions thereof, in his district.

(5) Place on Corps maps, brochures and otherwise adequately apprise the public and interested agencies of projects, or portions thereof, where seaplane operations are prohibited or restricted. Each map, brochure, or

other notice should clearly indicate that operation of a seaplane at Corps projects is at the risk of the plane's owner, operator, and/or passenger(s).

(6) Notify the FAA by letter of projects, or portions thereof, where seaplane operations are prohibited or restricted. The letter should use the words "seaplane operations prohibited," or "seaplane operations restricted," describe the geographical location of such areas as precisely as possible, describe any restrictions, include a telephone number for FAA to contact the District, and be sent to: Federal Aviation Administration, Area Traffic Service, Flight Services Division (AAT-432), 800 Independence Avenue SW., Washington, DC 20591.

(b) The removal of the present prohibition on seaplane operations will be effective one year from the date of publication of these regulations. The District Engineer should complete the examination, investigation, determination and notification to the FAA of projects, or portions thereof, where seaplane operations are prohibited or restricted, within one year from the date of this regulation. The District Engineer may extend the present prohibition for up to one additional year if he cannot complete his examination, investigation, determination, and notification within one year. In such event, he should notify the FAA by letter and publish other appropriate notices. Any further extension of time will require the approval of the Chief of Engineers.

(c) After he has completed his examination, investigation, determination and notification of the FAA of projects, or portions thereof where seaplane operations will be prohibited or restricted, The District Engineer should periodically reevaluate his determination as additional operational data becomes available. He may modify, delete, or add projects, or portions thereof, where seaplane operations are prohibited or restricted. Except where immediate action is required, he should consult with appropriate public authorities and private interests for their guidance with regard to such actions. Notification of these actions shall be forwarded to the FAA as indicated in paragraph (a)(6) of this section.



§ 328.7 Other authorities.

Nothing in the preceding provisions bestows authority to deviate from rules and regulations or prescribed standards of the State Aeronautical Agency, Federal Aviation Administration, Coast Guard, or other appropriate Federal, state, or local authority.

**PART 330—REGULATION OF LAW ENFORCEMENT SERVICES CONTRACTS AT CIVIL WORKS WATER RESOURCE PROJECTS ADMINISTERED BY THE CHIEF OF ENGINEERS**

- Sec.
- 330.1 Purpose.
- 330.2 Applicability.
- 330.3 References.
- 330.4 General.
- 330.5 Policy.
- 330.6 Criteria.
- 330.7 Funding.
- 330.8 Annual report.

AUTHORITY: Sec. 120 of the Water Resource Development Act of 1976, 90 Stat. 2917.

SOURCE: 42 FR 61986, Dec. 8, 1977, unless otherwise noted.

§ 330.1 Purpose.

This regulation provides policy and guidance for the establishment and management of the contract law enforcement program including preparation of and management of contracts ensuing from this program.

§ 330.2 Applicability.

This regulation is applicable to all field operating agencies having responsibilities for Civil Works water resource development projects.

§ 330.3 References.

- (a) Section 4 of the Flood Control Act of 1944, as amended (16 U.S.C. 460d).
- (b) Section 234 of the River and Harbor and Flood Control Act of 1970 (Pub. L. 91-611, 84 Stat. 1818).
- (c) Section 120 of the Water Resource Development Act of 1976 (Pub. L. 94-587, 90 Stat. 2917).
- (d) 36 CFR chapter III.
- (e) ER 190-2-3.
- (f) ER 190-3-4.

§ 330.4 General.

(a) Section 120(a) of reference § 330.3(c) authorizes the Secretary of the Army, acting through the Chief of Engineers, to contract with States and their political subdivisions for the purpose of obtaining increased law enforcement services at water resource development projects under the jurisdiction of the Secretary of the Army to meet needs during peak visitation periods.

(b) Further, section 120(b) of the Act authorizes a maximum appropriation of up to \$6,000,000 per fiscal year for the fiscal years ending 30 September 1978 and 30 September 1979, to carry out section 120(a).

§ 330.5 Policy.

(a) It is the policy of the Corps of Engineers to provide, to the extent of its authorities, a safe and healthful environment for public use of lands and waters at Civil Works water resource development projects. To insure this safe and healthful environment, and to augment the citation authorities granted to the Corps of Engineers by reference § 330.3(b), District Engineers, subject to the authority of the Division Engineers, as set out below, are hereby delegated the authority to contract with States or their political subdivisions to obtain increased law enforcement services at Civil Works water resource development projects. Division Engineers are hereby delegated the authority to approve any minor deviations from this regulation except that any substantial deviations from the policies expressed within this regulation will require the prior approval of the Chief of Engineers or his authorized representative. Any required approval for deviation shall be made prior to the execution of the contract. When fiscal year 1978 and fiscal year 1979 work allowances are issued, instructions will be furnished on reporting requirements and the control of expenditures.

(b) Contracts for law enforcement services, as authorized in § 330.5(a), shall be subject to the terms and conditions as provided for within this regulation and in accordance with standard contracting and accounting procedures applicable to the Corps of Engineers.

### § 330.6

### 36 CFR Ch. III (7-1-03 Edition)

(c) This regulation is not intended to diminish or otherwise limit the existing law enforcement responsibilities of the State or local law enforcement agencies.

(d) Contract law enforcement personnel shall not be given Federal citation authority for enforcement of regulations contained in title 36 of the Code of Federal Regulations, Chapter III nor shall they be empowered to enforce such regulations. These regulations shall remain the responsibility of the Corps of Engineers.

(e) Contracts for increased law enforcement shall be for those projects or portions of projects that are operated and maintained by the Corps of Engineers. Law enforcement services will not be provided under this program to those outgrant areas operated and maintained by a non-Federal sponsor.

#### § 330.6 Criteria.

(a) In order to provide reimbursement for law enforcement services supplied by a State or local law enforcement agency, a contract must be executed and approved in accordance with this regulation prior to the provisions of such services.

(b) The authorized contract law enforcement program extends only to 30 September 1979. Law enforcement services acquired by contract under this program shall be limited to those increased law enforcement services required to meet the needs of the public during peak visitation periods. Accordingly, the contract period shall not extend beyond the dates of 1 April through 30 September inclusive, and in no event shall the contract be written for more than 120 days within that time period. The contract may provide for an option to renew for a similar, additional period not to exceed 120-day period in Fiscal Year 1979. Any exceptions to this criteria must be approved by the Chief of Engineers or his authorized representative.

(c) Contracts shall be consummated only with those public law enforcement agencies legally empowered to enforce State and local criminal and civil laws within their respective political jurisdictions. In light of this requirement and the authority cited in § 330.3(c), it is recognized that sole source negotia-

tions may necessarily be utilized in the procurement of these services. In negotiating law enforcement contracts with these agencies the District Engineer must determine the reasonableness of the price for the law enforcement services offered under the contract. Such a determination shall be made prior to execution of the contract, in accordance with the applicable Contract Cost Principles and Procedures as set out in ASPR, section 15, part 7, and as subject to the policies contained in this regulation. Such a determination shall be contained in the official contract file and must accompany any requests for deviations from the Division Engineer or Chief of Engineers as provided for in § 330.5(a) of this regulation. Contract law enforcement personnel must meet all the qualifications, including minimal law enforcement training, required by State and local laws and regulations.

(d) The contractor shall provide all personnel, equipment and supplies which are required to provide the increased law enforcement services contracted for by the District Engineer. The Corps of Engineers shall not reimburse the contractor for the purchase of any equipment or supplies desired by the contractor for use under this program. However, the Corps of Engineers shall reimburse the contractor for the reasonable costs incurred by him in the rental or use of such equipment which is allocated to the work performed by him under the contract. Such use shall include:

(1) A depreciation or use allowance for such equipment as determined by the service life evaluation system used by the contractor, and (2) the costs of necessary maintenance, repair, and upkeep of the property which neither adds to the permanent value of the property nor appreciably prolongs its intended life, but keeps it at an efficient operating condition.

(e) Reimbursement for law enforcement services shall be considered only for increased law enforcement services to meet needs during peak visitation periods. Each District Engineer shall evaluate and establish a normal law enforcement service standard for each contract situation and include such standard in the plan of operation to be

developed in accordance with § 330.6(h). Each District Engineer shall evaluate the existing law enforcement services now being provided by State or local law enforcement agencies at those water resources projects or recreation areas where it is anticipated that law enforcement service contracts may be executed, and determine the scope including the type and amount, of law enforcement service which exceeds the normal law enforcement standard, and which will become eligible for reimbursement under the contract. Normally, requests by the District Engineer or his authorized representative for emergency or unanticipated law enforcement assistance will be considered nonreimbursable. Increased law enforcement services, eligible for reimbursement under the terms of the contract, shall be those regularly scheduled patrols or surveillance in excess of the normal law enforcement standard presently being provided by the contractor.

(f) An appropriate orientation program will be given by Corps personnel to all contract law enforcement personnel assigned to Corps projects. The purpose of this orientation will be to familiarize the contract law enforcement personnel with the policies and procedures of the Corps of Engineers, and to familiarize Corps personnel with the functions and duties of the State or local law enforcement agency. The Corps of Engineers shall reimburse the contractor for the cost per man hour as set out in § 330.6(h)(4) for attending the orientation program.

(g) The contractor shall be required to keep a record of the services provided to the District under the terms and conditions of the contract in accordance with the criteria established in the plan of operation required in § 330.6(h).

(h) The District Engineer, in cooperation with the Contractor, shall prepare a Plan of Operation for the Provision of law enforcement services as an attachment to the contract. The Plan of Operation shall contain, but not necessarily be limited to, the following information:

(1) Identify, by name and location, the project or projects and specific

areas (recreation and others) that require law enforcement services.

(2) Describe the normal law enforcement services to be provided by the Contractor without reimbursement by the Government (see § 330.6(e)). Identify time of day, number of hours-per-day, number of days-per-week, and the number of patrols.

(3) Describe the increased law enforcement services to be provided by the Contractor under the contract. Identify the time-of-day, number of hours-per-day, number of days-per-week, number of patrols, manpower per patrol, and effective starting and ending dates.

(4) Identify the cost-per-man-hour for the provision of reimbursable law enforcement services, and identify the costs for utilization and operation, maintenance and repair of such equipment as allocated for use under the contract. (See § 330.6(d).)

(5) The District Engineer and the Contractor should designate specific individuals to issue or receive requests for reimbursable law enforcement services under the contract.

(6) Describe the billing procedures to be utilized for the increased law enforcement services. The Contractor shall provide, at a minimum, the total charges, the number of hours involved, and starting and ending dates of the billing period.

(7) The Contractor shall prepare a Daily Law Enforcement Log (see § 330.6(g) for the law enforcement services rendered as specified in § 330.6(h)(3)). These logs shall be compiled by the Contractor and submitted to the District Engineer or his designated representative on a regular basis throughout the life of the contract. It is intended by this reporting requirement to minimize the paperwork burden on behalf of the Contractor while, at the same time, providing assurance to the Government with an adequate information base on which to administer the law enforcement services being provided under the contract. Any requirement for additional information to be contained in these reports due to unique or special circumstances encountered in negotiating a Plan of Operation with a particular law enforcement jurisdiction

**§ 330.7**

must receive the prior approval of the Division Engineer.

**§ 330.7 Funding.**

(a) Section 330.3(c) sets forth the maximum authorized funds for law enforcement contracting in FY 1978 and FY 1979. The Division funding levels for FY 1978 are based on information as previously submitted.

(b) The FY 1979 funding request for law enforcement contracting will be submitted as part of the FY 1979 budget submittal.

**§ 330.8 Annual report.**

(RCS-DAEN-CWO-53) The Division Engineer will submit a consolidated annual report to reach HQDA (DAEN-CWO-R) WASH DC 20314 not later than 30 October. This requirement expires 30 October 1979. The report will contain the following:

- (a) Districts reporting.
- (b) Number assigned each contract.
- (c) Name of projects covered under each contract.
- (d) Number of man-hours of increased law enforcement services provided under each contract.
- (e) Total contract cost.
- (f) Cost per man-hour for each contract.
- (g) Corps of Engineers administrative or overhead costs associated with each contract.
- (h) Number of arrests and type of offense committed, i.e., assault, burglary, auto theft, etc.
- (i) The Division Engineers assessment of the effects of the contract law enforcement program and recommendation.

**PART 331—REGULATIONS GOVERNING THE PROTECTION, USE AND MANAGEMENT OF THE FALLS OF THE OHIO NATIONAL WILDLIFE CONSERVATION AREA, KENTUCKY AND INDIANA**

- Sec.
- 331.1 Applicability and scope.
- 331.2 Policy.
- 331.3 Hunting and trapping.
- 331.4 Fishing.
- 331.5 Explosives and fireworks.
- 331.6 Public property.
- 331.7 Sanitation.

- 331.8 Picnicking.
- 331.9 Camping.
- 331.10 Swimming.
- 331.11 Special events.
- 331.12 Vehicles.
- 331.13 Vessels.
- 331.14 Aircraft.
- 331.15 Fires.
- 331.16 Interference with government employees.
- 331.17 Minerals.
- 331.18 Restrictions.
- 331.19 Commercial activities.
- 331.20 Advertisement.
- 331.21 Unauthorized structures.
- 331.22 Abandonment of personal property.
- 331.23 Control of animals.
- 331.24 Permits.
- 331.25 Violation of regulations.

AUTHORITY: Pub. L. 97-137.

SOURCE: 48 FR 40720, Sept. 9, 1983, unless otherwise noted.

**§ 331.1 Applicability and scope.**

(a) The regulations contained in this part apply to those lands and waters within the established boundary of the Falls of the Ohio National Wildlife Conservation Area (WCA). Included in this boundary, which was published in the FEDERAL REGISTER of August 12, 1982, are publicly and privately owned lands, waters and improvements. The Federal Government, acting through the Corps of Engineers, will acquire such rights to privately-owned properties in the WCA as are necessary to carry out the purposes of title II, Pub. L. 97-137. The regulations prescribed herein are for the use, management and protection of the resources of the WCA and all persons entering, using or visiting within the boundaries of the WCA are subject to these regulations. All other applicable Federal, State and local laws and regulations remain in full force and effect. The District Engineer, US Army Corps of Engineers, exercises non-exclusive jurisdiction over the lands and waters of the WCA and enforces these regulations.

(b) The WCA boundary encompasses an existing hydroelectric generating station and the McAlpine Locks and Dam, operating navigation structures which are part of the authorized Ohio River Navigation System. The continued operation and maintenance of this

system take precedence over the purposes of the WCA, except that such operation and maintenance will be consistent with the basic purpose of the WCA as regards prohibition of hunting, vandalism, and dumping of refuse. Management of the WCA to achieve its intended purposes will, to the extent practicable, be accomplished in a manner consistent and compatible with continued generation of electricity and navigation on the Ohio River, including operation and maintenance of the McAlpine Locks and Dam and the Louisville Repair Station and material storage areas located on Shippingport Island.

#### § 331.2 Policy.

(a) It is the policy of the Secretary of the Army, acting through the Chief of Engineers, to manage the natural and cultural resources of the WCA in the public interest, providing the public with safe and healthful recreational opportunities while protecting and enhancing these resources.

(b) Unless otherwise indicated herein, the term *District Engineer* shall include the authorized representatives of the District Engineer.

(c) The WCA shall be available to the public without regard to sex, race, color, creed or national origin. No lessee, licensee or concessionaire providing a service to the public shall discriminate against any person because of sex, race, creed, color, or national origin in the conduct of the operations under the lease, license, or concession contract.

#### § 331.3 Hunting and trapping.

Unless authorized in writing by the District Engineer:

(a) The hunting, trapping, catching, molesting, killing, or having in possession any wild animal or bird, or taking the eggs of any such bird, is prohibited.

(b) Possession of equipment (including, but not limited to, firearms, ammunition, traps, projectile firing devices including bow and arrow) which could be used for hunting, trapping, or the taking of wildlife, is prohibited.

#### § 331.4 Fishing.

Unless otherwise authorized in writing by the District Engineer:

(a) Fishing is only permitted in accordance with the laws and regulations of the State within whose exterior boundaries that portion of the WCA is located, and such laws and regulations which are now or may hereafter be in effect are hereby adopted as part of these regulations.

(b) Fishing by means of the use of drugs, poisons, explosives, bow and arrow or electricity is prohibited.

(c) Commercial fishing and fishing with gill nets, trammel nets, hoop nets, bow and arrow or trot lines is prohibited.

#### § 331.5 Explosives and fireworks.

Unless otherwise authorized in writing by the District Engineer.

(a) The possession or use of fireworks is prohibited.

(b) The possession or use of explosives is prohibited.

#### § 331.6 Public property.

Unless otherwise authorized in writing by the District Engineer, the destruction, injury, defacement, removal, or any alteration of public property including, but not limited to natural formations, paleontological features, historical and archaeological features and vegetative growth is prohibited. Any such destruction, removal, or alteration of public property shall be in accordance with the conditions of any permission granted.

#### § 331.7 Sanitation.

(a) Garbage, trash, rubbish, litter, or any other waste material or waste liquid generated on the WCA shall be removed from the area or deposited in receptacles provided for that purpose. The improper disposal of such wastes within the boundaries of the WCA is prohibited.

(b) The use of refuse containers for the disposal of refuse not generated on the WCA is prohibited.

(c) It is a violation to bring any material onto the WCA for the purpose of disposal.

(d) The discharge or placing of sewage, galley waste, garbage, refuse or pollutants into the WCA waters from any vessel or watercraft is prohibited.

**§ 331.8**

**§ 331.8 Picnicking.**

(a) Picnicking is permitted only in designated areas.

(b) Picnickers shall remove all personal equipment and clean their sites upon departure.

**§ 331.9 Camping.**

Camping is not permitted within the WCA.

**§ 331.10 Swimming.**

Swimming is prohibited unless authorized in writing by the District Engineer.

**§ 331.11 Special events.**

(a) Special events including, but not limited to, water carnivals, boat regattas, music festivals, dramatic presentations, or other special recreation programs are prohibited unless written permission has been granted by the District Engineer.

(b) The public shall not be charged any fee by the sponsor of such permitted event unless the District Engineer has approved in writing the proposed schedule of fees. The District Engineer shall have authority to revoke permission and require removal of any equipment upon failure of the sponsor to comply with terms and conditions of the permit/permission. Any violation shall constitute a separate violation for each calendar day in which it occurs.

**§ 331.12 Vehicles.**

(a) The use of a vehicle off roadways is prohibited except as may be authorized by the District Engineer.

(b) Vehicles shall not be parked in violation of any posted restriction, or in such a manner as to endanger any Federal property to include natural features. The owner of any vehicle parked in violation of this section shall be presumed to have parked it, and unless rebutted such presumption will be sufficient to sustain a conviction as provided for in § 331.25.

(c) Vehicles shall be operated in accordance with all posted regulations.

(d) Driving or operating any vehicle in a careless, negligent, or reckless manner, heedlessly or in willful disregard for the safety of other persons,

or in such manner as to endanger any property or environmental feature, or without due care or at a speed greater than is reasonable and prudent under prevailing conditions with regard to traffic, weather, road, light and surface conditions, is prohibited.

(e) This section pertains to all vehicles, including, but not limited to, automobiles, trucks, motorcycles, minibikes, trail bikes, snowmobiles, dune buggies, all terrain vehicles, bicycles, trailers, campers, or any other such equipment.

(f) Except as authorized by the District Engineer, no person shall operate any motorized vehicle without a proper and effective exhaust muffler, or with an exhaust muffler cutout open, or in any other manner which renders the exhaust muffler ineffective in muffling the sound of engine exhaust.

**§ 331.13 Vessels.**

(a) Vessels or other watercraft may be operated in the WCA waters except in prohibited or restricted areas in accordance with posted regulations and applicable Federal, State and local laws.

(b) All vessels when not in actual use shall be removed from the WCA unless securely moored at mooring facilities approved by the District Engineer. The placing of floating or stationary mooring facilities to, or interfering with, a buoy, channel marker, or other navigational aid is prohibited.

(c) The operation of vessels or other watercraft in a careless, negligent, or reckless manner so as to endanger any property (including the operator and/or user(s) of the vessel or watercraft) is prohibited.

**§ 331.14 Aircraft.**

(a) The operation of aircraft on WCA lands and waters is prohibited, unless authorized in writing by the District Engineer.

(b) Except in extreme emergencies threatening human life or serious property loss, the air delivery of any person or thing by parachute, helicopter, or other means onto project lands or waters without written permission of the District Engineer is prohibited.

## Corps of Engineers, Army, DoD

## § 331.22

(c) The provisions of this section shall not be applicable to aircraft engaged on official business of the Federal Government or used in emergency rescue in accordance with the directions of the District Engineer.

### § 331.15 Fires.

Open fires are prohibited unless confined to fireplaces, grills, or other facilities designed for this purpose as designated by the District Engineer. Fires shall not be left unattended and must be completely extinguished prior to departure.

### § 331.16 Interference with government employees.

Interference with any Government employee in the conduct of his or her official duties pertaining to the administration of these regulations is prohibited. It is a violation to fail to comply with a lawful order directed by any Government employee or to knowingly give any false, fictitious, or fraudulent report or other information to any government employee in the performance of his or her official duties pertaining to the administration of these regulations.

### § 331.17 Minerals.

All activities in connection with prospecting, exploration, development, mining or other removal or the processing of mineral resources and all uses reasonably incident thereto are prohibited.

### § 331.18 Restrictions.

The District Engineer may establish and post a schedule of visiting hours and/or restrictions on the public use of a portion or portions of the WCA. The District Engineer may close or restrict the use of the WCA or portion of the WCA when necessitated by reason of public health, public safety, security, maintenance, or other reasons in the public interest. Entering or using the project in a manner which is contrary to the schedule of visiting hours, closure or restrictions is prohibited.

### § 331.19 Commercial activities.

Unless otherwise authorized in writing by the District Engineer, the en-

gaging in or solicitation of business or money is prohibited.

### § 331.20 Advertisement.

Unless otherwise authorized in writing by the District Engineer, advertising by the use of billboards, signs, markers, audio devices, or any other means whatsoever including handbills, circulars, and posters is prohibited. Vessels or vehicles with semipermanent or permanently installed signs are exempt if being used for authorized recreational activities or special events and in compliance with all other rules and regulations pertaining to vessels and vehicles.

### § 331.21 Unauthorized structures.

The construction, placing, or continued existence of any structure of any kind under, upon, in, or over WCA lands or waters is prohibited unless a permit, lease, license, or other appropriate written agreement therefor has been issued by the District Engineer. Structures not so authorized are subject to summary removal or impoundment by the District Engineer. The design, construction, placing, existence, or use of structures in violation of the terms of the permit, lease, license, or other written agreement therefor is prohibited.

### § 331.22 Abandonment of personal property.

(a) Personal property of any kind left unattended upon WCA lands or waters for a period of 24 hours shall be considered abandoned and may be impounded and stored at a storage point designated by the District Engineer who may assess a reasonable impoundment fee. Such fee shall be paid before the impounded property is returned to its owner.

(b) If abandoned property is not claimed by its owner within 3 months after the date it is received at the storage point designated by the District Engineer, it may be disposed of by public or private sale or by other means determined by the District Engineer. Any net proceeds from the sale of property shall be conveyed unto the Treasury of the United States as miscellaneous receipts.

**§ 331.23**

**§ 331.23 Control of animals.**

(a) No person shall bring or allow horses, cattle, or other livestock in the WCA.

(b) No person shall bring dogs, cats, or other pets into the WCA unless penned, caged, or on a leash under 6 feet in length, or otherwise under physical restraint at all times. Unclaimed or unattended animals are subject to immediate impoundment and removal in accordance with State and local laws.

**§ 331.24 Permits.**

It shall be a violation of these regulations to refuse to or fail to comply with the terms or conditions of any permit issued by the District Engineer.

**36 CFR Ch. III (7-1-03 Edition)**

**§ 331.25 Violation of regulations.**

Anyone violating the provisions of this regulation shall be subject to a fine of not more than \$500 or imprisonment for not more than 6 months, or both. All persons designated by the Chief of Engineers, U.S. Army Corps of Engineers, for that purpose shall have the authority to issue a citation for the violation of these regulations, requiring the appearance of any person charged with violation to appear before the U.S. Magistrate within whose jurisdiction the violation occurred.

**PARTS 332-399 [RESERVED]**



## CHAPTER IV—AMERICAN BATTLE MONUMENTS COMMISSION

---

<i>Part</i>		<i>Page</i>
400	Employee responsibilities and conduct .....	37
401	Procedures .....	38
402	Erection of war memorials in foreign countries by American citizens, States, municipalities, or as- sociations .....	39
403	Erection of memorial monuments, buildings, and headstones in American cemeteries located out- side the United States and its Territories and possessions .....	39
404	Procedures and guidelines for compliance with the Freedom of Information Act .....	39
406	Enforcement of nondiscrimination on the basis of handicap in programs or activities conducted by American Battle Monuments Commission .....	46
407-499	[Reserved]	



## **PART 400—EMPLOYEE RESPONSIBILITIES AND CONDUCT**

Sec.

400.735-1 Adoption of regulations.

400.735-2 Review of statements of employment and financial interests.

400.735-3 Disciplinary and other remedial action.

400.735-4 Gifts, entertainment, and favors.

400.735-5 Outside employment and other activity.

400.735-6 Specific provisions of agency regulations governing special Government employees.

400.735-7 Statements of employment and financial interests.

400.735-8 Supplementary statements.

AUTHORITY: E.O. 11222, 30 FR 6469, 3 CFR 1965 Supp.; 5 CFR 735.101 *et seq.*

SOURCE: 33 FR 15379, Oct. 17, 1968, unless otherwise noted.

### **§ 400.735-1 Adoption of regulations.**

Pursuant to 5 CFR 735.104(f), the American Battle Monuments Commission (referred to hereinafter as the agency) hereby adopts the following sections of part 735 of title 5, Code of Federal Regulations: §§ 735.101, 735.102, 735.201a, 735.202 (a), (d), (e), (f), 735.210, 735.302, 735.303(a), 735.304, 735.305(a), 735.403(a), 735.404, 735.405, 735.407—735.411, 735.412 (b) and (d). These adopted sections are modified and supplemented as set forth in this part.

### **§ 400.735-2 Review of statements of employment and financial interests.**

Each statement of employment and financial interests submitted under this part shall be reviewed by the Officer in Charge, U.S. Office, except those of the Officer in Charge, U.S. Office, and the Secretary, American Battle Monuments Commission. The statement of the Officer in Charge, U.S. Office, shall be reviewed by the Secretary of the American Battle Monuments Commission. The statement of the Secretary, American Battle Monuments Commission, shall be reviewed by the Chairman of the Agency. When a review indicates a conflict between the interests of an employee or special Government employee of the agency and the performance of his services for

the Government, the reviewer shall have the indicated conflict brought to the attention of the employee or special Government employee, grant the employee or special Government employee an opportunity to explain the indicated conflict, and attempt to resolve the indicated conflict. If the indicated conflict cannot be resolved, the reviewer shall forward a written report on the indicated conflict to the Chairman, American Battle Monuments Commission, through the counselor for the agency designated under 5 CFR 735.105(a).

### **§ 400.735-3 Disciplinary and other remedial action.**

An employee or special Government employee of the agency who violates any of the regulations in this part or adopted under § 400.735-1 may be disciplined. The disciplinary action may be in addition to any penalty prescribed by law for the violation. In addition to or in lieu of disciplinary action, remedial action to end conflicts or appearance of conflicts of interest may include but is not limited to:

(a) Changes in assigned duties;

(b) Divestment by the employee or special Government employee of his conflicting interest; or

(c) Disqualification for a particular assignment.

### **§ 400.735-4 Gifts, entertainment, and favors.**

The agency authorizes the exceptions to 5 CFR 735.202(a) set forth in 5 CFR 735.202(b) (1)–(4).

### **§ 400.735-5 Outside employment and other activity.**

An employee of the agency may engage in outside employment or other outside activity not incompatible with the full and proper discharge of the duties and responsibilities of his Government employment. An employee who engages in outside employment shall report that fact in writing to his supervisor.

**§ 400.735-6**

**§ 400.735-6 Specific provisions of agency regulations governing special Government employees.**

(a) Special Government employees of the agency shall adhere to the standards of conduct applicable to employees as set forth in this part and adopted under § 400.735-1, except 5 CFR 735.203(b).

(b) Special Government employees of the agency may teach, lecture, or write in a manner not inconsistent with 5 CFR 735.203(c).

(c) Pursuant to 5 CFR 735.305(b), the agency authorizes the same exceptions concerning gifts, entertainment, and favors for special Government employees as are authorized for employees by § 400.735-4.

**§ 400.735-7 Statements of employment and financial interests.**

(a) In addition to the employees required to submit statements of employment and financial interests under 5 CFR 735.403(a), employees in the following named positions shall submit statements of employment and financial interests:

- (1) Secretary;
- (2) Officer in Charge, U.S. Office;
- (3) Officer in Charge, European Office;
- (4) Chief Maintenance Division, European Office;
- (5) Chief Purchasing and Contracting Branch, European Office;
- (6) Officer in Charge, Mediterranean Office;
- (7) Superintendent, Manila American Cemetery.

(b) Each statement of employment and financial interests required by this section shall be submitted to:

American Battle Monuments Commission  
2018 Munitions Building, Washington, DC  
20360. Attention: Officer in Charge.

Statements shall be submitted in double sealed envelopes, and the inner envelope shall be annotated with the words: "Statement of Employment and Financial Interests—Attention: Officer in Charge."

(c) An employee who believes that his position has been improperly included in this section as one requiring the submission of a statement of employment and financial interests may ob-

**36 CFR Ch. IV (7-1-03 Edition)**

tain a review of his complaint under the agency's grievance procedure.

**§ 400.735-8 Supplementary statements.**

Notwithstanding the filing of the annual supplementary statement required by 5 CFR 735.406, each employee shall at all times avoid acquiring a financial interest that could result, or taking an action that would result, in a violation of the conflicts-of-interest provisions of section 208 of title 18 U.S.C. or the regulations in this part or adopted under § 400.735-1.

**PART 401—PROCEDURES**

AUTHORITY: Sec. 3, 70 Stat. 640, 641; 5 U.S.C. 132 note, 36 U.S.C. 123-125; E.O. 6614, E.O. 9704, 11 FR 2675, 3 CFR 1949-53 Comp., p. 519, E.O. 10057, 10087, 14 FR 2585, 7287, 3 CFR 1949-1953 Comp., pp. 269, 285.

**§ 401.1 Erection of war memorials outside continental limits of United States.**

Federal Government agencies, American citizens, States, municipalities, or associations desiring to erect war memorials outside the continental limits of the United States should proceed as follows:

(a) Submit general idea of the memorial to the American Battle Monuments Commission, with a request for the tentative allocation of the site desired.

(b) When site is provisionally allocated, prepare and submit the design of the memorial, together with the inscription, for approval. The design of the memorial will then be referred, in accordance with law, by the Commission to the National Commission of Fine Arts for its approval.

(c) After a site is allocated and the design and inscription are approved, the American Battle Monuments Commission will, if the sponsors so desire, consult with the foreign government concerning the question of securing approval for the erection of the memorial.

(d) When the approval of the foreign government is obtained, the Commission will cooperate, if the sponsors so desire, in obtaining the ground and erection of the memorial. Such cooperation may include construction of

## American Battle Monuments Commission

## § 404.1

the memorial by the Commission, using funds provided by the sponsors, in which case user charges will be made in accordance with general Government policy.

[35 FR 19666, Dec. 29, 1970]

### **PART 402—ERECTION OF WAR MEMORIALS IN FOREIGN COUNTRIES BY AMERICAN CITIZENS, STATES, MUNICIPALITIES, OR ASSOCIATIONS**

AUTHORITY: Sec. 3, 70 Stat. 640, 641; 5 U.S.C. 132 note, 36 U.S.C. 123, 125; E.O. 6614, E.O. 9704, 11 FR 2675, 3 CFR 1943-1948 Comp., p. 519, E.O. 10057, 10087, 14 FR 2585, 7287, 3 CFR, 1949-1953 Comp., pp. 269, 285.

#### **§ 402.1 Restrictions on erection.**

(a) No administrative agency of the United States shall give assistance to American citizens, States, municipalities, or associations in erecting any war memorial outside the continental United States unless the plan has been approved in accordance with § 401.1 above.

(b) It is the opinion of the Commission that no battlefield memorial should be erected to any unit smaller than a division or comparable unit or to an individual, unless the services of such unit or individual clearly were of such distinguished character as to warrant a separate memorial.

(c) It is the opinion of the Commission that, as a general rule, memorials should be erected to organizations rather than to troops from a particular locality of the United States.

(d) The policy of the Commission is to approve plans for memorials in foreign countries only in cases in which the sponsors make adequate and permanent arrangements for their maintenance. If the sponsors so desire, the Commission will maintain such memorials, including those previously existing which it deems worthy of preservation, using funds provided by the sponsors; in such cases it will make user charges in accordance with general Government policy.

[35 FR 19666, Dec. 29, 1970]

### **PART 403—ERECTION OF MEMORIAL MONUMENTS, BUILDINGS, AND HEADSTONES IN AMERICAN CEMETERIES LOCATED OUTSIDE THE UNITED STATES AND ITS TERRITORIES AND POSSESSIONS**

AUTHORITY: Sec. 3, 70 Stat. 641; 36 U.S.C. 123; E.O. 6614, Feb. 26, 1934; E.O. 9704, 3 CFR, 1943-1948 Comp., 519; E.O. 10057, 10087, 3 CFR 1949-1953 Comp., pp. 269, 285.

#### **§ 403.1 Restrictions on erection.**

(a) No memorial monuments or buildings shall be placed in these cemeteries unless the design and site have been approved by the American Battle Monuments Commission. No steps toward the erection of any memorial monument or building in these cemeteries should be taken until the idea has first been approved by the American Battle Monuments Commission.

(b) There shall be no variation in the types of headstones officially adopted for use in American cemeteries located outside the United States and its Territories and possessions.

[13 FR 6812, Nov. 19, 1948, as amended at 23 FR 9780, Dec. 19, 1958]

### **PART 404—PROCEDURES AND GUIDELINES FOR COMPLIANCE WITH THE FREEDOM OF INFORMATION ACT**

Sec.

- 404.1 General.
- 404.2 Authority and functions.
- 404.3 Organization.
- 404.4 Access to information.
- 404.5 Inspection and copying.
- 404.6 Definitions.
- 404.7 Fees to be charged—general.
- 404.8 Fees to be charged—categories of requesters.
- 404.9 Miscellaneous fee provisions.
- 404.10 Waiver or reduction of charges.

AUTHORITY: 5 U.S.C. 552.

SOURCE: 68 FR 8826, Feb. 26, 2003, unless otherwise noted.

#### **§ 404.1 General.**

This information is furnished for the guidance of the public and in compliance with the requirements of section 552 of Title 5, United States Code, as amended.

## § 404.2

## 36 CFR Ch. IV (7-1-03 Edition)

### § 404.2 Authority and functions.

The general functions of the American Battle Monuments Commission, as provided by statute, 36 U.S.C. Section 2101, *et seq.*, are to build and maintain suitable memorials commemorating the service of American Armed Forces and to maintain permanent American military cemeteries in foreign countries.

### § 404.3 Organization.

(a) The brief description of the central organization of the American Battle Monuments Commission follows:

(1) The Commission is composed of not more than 11 members appointed by the President.

(2) The day to day operation of the Commission is under the direction of a Secretary appointed by the President.

(3) Principal Officials include the Executive Director, Director of Finance, Director of Procurement and Contracting, Director of Engineering, Maintenance, and Operations and Director of Personnel and Administration.

(4) The Commission also creates temporary offices when tasked with major additional responsibilities not of a permanent nature.

(b) *Locations.* (1) The principal offices of the American Battle Monuments Commission are located at Courthouse Plaza II, Suite 500, 2300 Clarendon Boulevard, Arlington, VA 22201. Persons desiring to visit offices or employees of the American Battle Monuments Commission should write or telephone ahead (703-696-6897 or 703-696-6895) to make an appointment.

(2) Field offices are located in Paris, France; Rome, Italy; Manila, Republic of the Philippines; the Republic of Panama; and Mexico City, Mexico.

### § 404.4 Access to information.

(a) The American Battle Monuments Commission makes available information pertaining to Commission matters within the scope of 5 U.S.C. 552(a)(2) by publishing them electronically at the ABMC home page at <http://www.abmc.gov>.

(b) The ABMC FOIA Officer is responsible for acting on all initial requests. Individuals wishing to file a request under the Freedom of Information Act

(FOIA) should address their request in writing to the FOIA Officer, American Battle Monuments Commission, Courthouse Plaza II, Suite 500, 2300 Clarendon Boulevard, Arlington, VA 22201 (telephone 703-696-6897 or 703-696-6895). Requests for information shall be as specific as possible.

(c) Upon receipt of any request for information or records, the FOIA Officer will determine within 20 days (excepting Saturdays, Sundays and legal public holidays) after the receipt of such request whether it is appropriate to grant the request and will immediately provide written notification to the person making the request. If the request is denied, the written notification to the person making the request shall include the names of the individuals who participated in the determination, the reasons for the denial, and a notice that an appeal may be lodged within the American Battle Monuments Commission. (Receipt of a request as used herein means the date the request is received in the office of the FOIA Officer.)

(d) *Expedited processing.* (1) Requests and appeals will be taken out of order and given expedited treatment whenever it is determined that they involve:

(i) Circumstances in which the lack of expedited treatment could reasonably be expected to pose an imminent threat to the life or physical safety of an individual;

(ii) An urgency to inform the public about an actual or alleged federal government activity, if made by a person primarily engaged in disseminating information;

(iii) The loss of substantial due process rights; or

(iv) A matter of widespread and exceptional media interest in which there exist possible questions about the government's integrity which effect public confidence.

(2) A request for expedited processing may be made at the time of the initial request for records or at any later time.

(3) A requester who seeks expedited processing must submit a statement, certified to be true and correct to the best of that person's knowledge and belief, explaining in detail the basis for requesting expedited processing. For

example, a requester within the category described in paragraph (d)(1)(ii) of this section, if not a full-time member of the news media, must establish that he or she is a person whose main professional activity or occupation is information dissemination, though it need not be his or her sole occupation. A requester within the category (d)(1)(ii) of this section also must establish a particular urgency to inform the public about the government activity involved in the request, beyond the public's right to know about government activity generally. The formality of certification may be waived as a matter of administrative discretion.

(4) Within 10 days of its receipt of a request for expedited processing, ABMC will decide whether to grant it and will notify the requester of the decision. If a request for expedited treatment is granted, the request will be given priority and will be processed as soon as practicable. If a request for expedited processing is denied, any appeal of that decision will be acted on expeditiously.

(e) Appeals shall be set forth in writing within 30 days of receipt of a denial and addressed to the FOIA Officer at the address specified in paragraph (b) of this section. The appeal shall include a statement explaining the basis for the appeal. Determinations of appeals will be set forth in writing and signed by the Executive Director, or his designee, within 20 days (excepting Saturdays, Sundays, and legal public holidays). If, on appeal, the denial is in whole or in part upheld, the written determination will also contain a notification of the provisions for judicial review and the names of the persons who participated in the determination.

(f) In unusual circumstances, the time limits prescribed in paragraphs (c) and (e) of this section may be extended for not more than 10 days (excepting Saturdays, Sundays, or legal public holidays). Extensions may be granted by the FOIA Officer. The extension period may be split between the initial request and the appeal but in no instance may the total period exceed 10 working days. Extensions will be by written notice to the persons making the request and will set forth the reasons for the extension and the date the determination is expected.

(g) With respect to a request for which a written notice under paragraph (f) of this section extends the time limits prescribed under paragraph (c) of this section, the agency shall notify the person making the request if the request cannot be processed within the time limit specified in paragraph (f) of this section and shall provide the person an opportunity to limit the scope of the request so that it may be processed within that time limit or an opportunity to arrange with the agency an alternative time frame for processing the request or a modified request. Refusal by the person to reasonably modify the request or arrange such an alternative time frame shall be considered as a factor in determining whether exceptional circumstances exist for purposes of 5 U.S.C. 552(a)(6)(C). When ABMC reasonably believes that a requester, or a group of requestors acting in concert, has submitted requests that constitute a single request, involving clearly related matters, ABMC may aggregate those requests for purposes of this paragraph. One element to be considered in determining whether a belief would be reasonable is the time period over which the requests have occurred.

(h) As used herein, but only to the extent reasonably necessary to the proper processing of the particular request, the term unusual circumstances means:

(1) The need to search for and collect the requested records from establishments that are separated from the office processing the request;

(2) The need to search for, collect, and appropriately examine a voluminous amount of separate and distinct records which are demanded in a single request; or

(3) The need for consultation, which shall be conducted with all practicable speed, with another agency having a substantial interest in the determination of the request or among two or more components of the agency which have a substantial subject matter interest therein.

#### § 404.5 Inspection and copying.

When a request for information has been approved pursuant to § 404.4, the person making the request may make

an appointment to inspect or copy the materials requested during regular business hours by writing or telephoning the FOIA Officer at the address or telephone number listed in § 404.4(b). Such materials may be copied and reasonable facilities will be made available for that purpose. Copies of individual pages of such materials will be made available at the price per page specified in § 404.7(d); however, the right is reserved to limit to a reasonable quantity the copies of such materials which may be made available in this manner when copies also are offered for sale by the Superintendent of Documents.

#### § 404.6 Definitions.

For the purpose of these regulations:

(a) All the terms defined in the Freedom of Information Act apply.

(b) A *statute specifically providing for setting the level of fees for particular types of records* (5 U.S.C. 552(a)(4)(A)(vi)) means any statute that specifically requires a government agency, such as the Government Printing Office (GPO) or the National Technical Information Service (NTIS), to set the level of fees for particular types of records, in order to:

(1) Serve both the general public and private sector organizations by conveniently making available government information;

(2) Ensure that groups and individuals pay the cost of publications and other services that are for their special use so that these costs are not borne by the general taxpaying public;

(3) Operate an information dissemination activity on a self-sustaining basis to the maximum extent possible; or

(4) Return revenue to the Treasury for defraying, wholly or in part, appropriated funds used to pay the cost of disseminating government information. Statutes, such as the User Fee Statute, which only provide a general discussion of fees without explicitly requiring that an agency set and collect fees for particular documents do not supersede the Freedom of Information Act under section (a)(4)(A)(vi) of that statute.

(c) The term *direct costs* means those expenditures that ABMC actually in-

curs in searching for and duplicating (and in the case of commercial requesters, reviewing) documents to respond to a FOIA request. Direct costs include, for example, the salary of the employee performing work (the basic rate of pay for the employee plus 16 percent of that rate to cover benefits) and the cost of operating duplicating machinery. Not included in direct costs are overhead expenses such as costs of space, and heating or lighting the facility in which the records are stored.

(d) The term *search* means the process of looking for and retrieving records or information responsive to a request. It includes page-by-page or line-by-line identification of information within records and also includes reasonable efforts to locate and retrieve information from records maintained in electronic form or format. ABMC employees should ensure that searching for material is done in the most efficient and least expensive manner so as to minimize costs for both the agency and the requester. For example, employees should not engage in line-by-line search when merely duplicating an entire document would prove the less expensive and quicker method of complying with a request. Search should be distinguished, moreover, from review of material in order to determine whether the material is exempt from disclosure (see paragraph (f) of this section).

(e) The term *duplication* means the making of a copy of a document, or of the information contained in it, necessary to respond to a FOIA request. Such copies can take the form of paper, microform, audio-visual materials, or electronic records (e.g., magnetic tape or disk), among others. The requester's specified preference of form or format of disclosure will be honored if the record is readily reproducible in that format.

(f) The term *review* refers to the process of examining documents located in response to a request that is for a commercial use (see paragraph (g) of this section) to determine whether any portion of any document located is permitted to be withheld. It also includes processing any documents for disclosure, e.g., doing all that is necessary to excise them and otherwise prepare



them for release. Review does not include time spent resolving general legal or policy issues regarding the application of exemptions.

(g) The term *commercial use request* refers to a request from or on behalf of one who seeks information for a use or purpose that furthers the commercial, trade, or profit interests of the requester or the person on whose behalf the request is made. In determining whether a requester properly belongs in this category, ABMC must determine the use to which a requester will put the documents requested. Moreover, where an ABMC employee has reasonable cause to doubt the use to which a requester will put the records sought, or where that use is not clear from the request itself, the employee should seek additional clarification before assigning the request to a specific category.

(h) The term *educational institution* refers to a preschool, a public or private elementary or secondary school, an institution of graduate higher education, an institution of undergraduate higher education, an institution of professional education, or an institution of vocational education, that operates a program or programs of scholarly research.

(i) The term *non-commercial scientific institution* refers to an institution that is not operated on a commercial basis (as that term is referenced in paragraph (g) of this section), and that is operated solely for the purpose of conducting scientific research the results of which are not intended to promote any particular product or industry.

(j) The term *representative of the news media* refers to any person actively gathering news for an entity that is organized and operated to publish or broadcast news to the public. The term news means information that is about current events or that would be of current interest to the public. Examples of news media entities include television or radio stations broadcasting to the public at large, and publishers of periodicals (but only in those instances when they can qualify as disseminators of news) who make their products available for purchase or subscription by the general public. These examples are not intended to be all-inclusive.

Moreover, as traditional methods of news delivery evolve (e.g., electronic dissemination of newspapers through telecommunications services), such alternative media would be included in this category. In the case of freelance journalists, they may be regarded as working for a news organization if they can demonstrate a solid basis for expecting publication through that organization, even though not actually employed by it. A publication contract would be the clearest proof, but ABMC may also look to the past publication record of a requester in making this determination.

#### § 404.7 Fees to be charged—general.

ABMC shall charge fees that recoup the full allowable direct costs it incurs. Moreover, it shall use the most efficient and least costly methods to comply with requests for documents made under the FOIA. When documents that would be responsive to a request are maintained for distribution by agencies operating statutory-based fee schedule programs (see definition in § 404.6(b)), such as the NTIS, ABMC should inform requesters of the steps necessary to obtain records from those sources.

(a) *Manual searches for records.* ABMC will charge at the salary rate(s) (i.e., basic pay plus 16 percent) of the employee(s) making the search.

(b) *Computer searches for records.* ABMC will charge at the actual direct cost of providing the service. This will include the cost of operating the central processing unit (CPU) for that portion of operating time that is directly attributable to searching for records responsive to a FOIA request and operator/programmer salary apportionable to the search.

(c) *Review of records.* Only requesters who are seeking documents for commercial use may be charged for time spent reviewing records to determine whether they are exempt from mandatory disclosure. Charges may be assessed only for the initial review; i.e., the review undertaken the first time ABMC analyzes the applicability of a specific exemption to a particular record or portion of a record. Records or portions of records withheld in full under an exemption that is subsequently determined not to apply may

#### § 404.8

#### 36 CFR Ch. IV (7-1-03 Edition)

be reviewed again to determine the applicability of other exemptions not previously considered. The costs for such a subsequent review is assessable.

(d) *Duplication of records.* Records will be duplicated at a rate of \$.15 per page. For copies prepared by computer, such as tapes or printouts, ABMC shall charge the actual cost, including operator time, of production of the tape or printout. For other methods of reproduction or duplication, ABMC will charge the actual direct costs of producing the document(s). If ABMC estimates that duplication charges are likely to exceed \$25, it shall notify the requester of the estimated amount of fees, unless the requester has indicated in advance his willingness to pay fees as high as those anticipated. Such a notice shall offer a requester the opportunity to confer with agency personnel with the object of reformulating the request to meet his or her needs at a lower cost.

(e) *Other charges.* When it elects to charge them, ABMC will recover the full costs of providing services such as:

(1) Certifying that records are true copies;

(2) Sending records by special methods such as express mail.

(3) Eight by ten inch black and white photographs—\$3.75

(4) Eight by ten inch color photographs—\$5.00

(5) \$1.50 per publication

(6) Video Purchase: The Price of Freedom—\$13.00

(f) Remittances shall be in the form either of a personal check or bank draft drawn on a bank in the United States, or a postal money order. Remittances shall be made payable to the order of the Treasury of the United States and mailed to the FOIA Officer, American Battle Monuments Commission, Courthouse Plaza II, Suite 500, 2300 Clarendon Blvd., Arlington, Virginia 22201

(g) *A receipt for fees paid will be given upon request.* Refund of fees paid for services actually rendered will not be made.

(h) *Restrictions on assessing fees.* With the exception of requesters seeking documents for a commercial use, ABMC will provide the first 100 pages of duplication and the first 2 hours of

search time without charge. Moreover, ABMC will not charge fees to any requester, including commercial use requesters, if the cost of collecting a fee would be equal to or greater than the fee itself.

(1) The elements to be considered in determining the cost of collecting a fee are the administrative costs of receiving and recording a requester's remittance, and processing the fee for deposit in the Treasury Department's special account.

(2) For purposes of these restrictions on assessment of fees, the word *pages* refers to paper copies of 8½ × 11 or 11 × 14. Thus, requesters are not entitled to 100 microfiche or 100 computer disks, for example. A microfiche containing the equivalent of 100 pages or 100 pages of computer printout, does meet the terms of the restriction.

(3) Similarly, the term *search time* in this context has as its basis, manual search. To apply this term to searches made by computer, ABMC will determine the hourly cost of operating the central processing unit and the operator's hourly salary plus 16 percent. When the cost of search (including the operator time and the cost of operating the computer to process a request) equals the equivalent dollar amount of two hours of the salary of the person performing the search, *i.e.*, the operator, ABMC will begin assessing charges for computer search.

#### § 404.8 Fees to be charged—categories of requesters.

There are four categories of FOIA requesters: commercial use requesters; educational and noncommercial scientific institutions; representatives of the news media; and all other requesters. The specific levels of fees for each of these categories:

(a) *Commercial use requesters.* When ABMC receives a request for documents for commercial use, it will assess charges that recover the full direct costs of searching for, reviewing for release, and duplicating the record sought. Requesters must reasonably describe the records sought. Commercial use requesters are not entitled to 2 hours of free search time nor 100 free pages of reproduction of documents.

ABMC may recover the cost of searching for and reviewing records even if there is ultimately no disclosure of records (see paragraph (b) of this section).

(b) *Educational and noncommercial scientific institution requesters.* ABMC shall provide documents to requesters in this category for the cost of reproduction alone, excluding charges for the first 100 pages. To be eligible for inclusion in this category, requesters must show that the request is being made as authorized by and under the auspices of a qualifying institution and that the records are not sought for a commercial use, but are sought in furtherance of scholarly (if the request is from an educational institution) or scientific (if the request is from a non-commercial scientific institution) research. Requesters must reasonably describe the records sought.

(c) *Requesters who are representatives of the news media.* ABMC shall provide documents to requesters in this category when serving the news dissemination function for the cost of reproduction alone, excluding charges for the first 100 pages. To be eligible for inclusion in this category, a requester must meet the criteria in § 404.4(j), and his or her request must not be made for a commercial use. In reference to this class of requester, a request for records supporting the news dissemination function of the requester shall not be considered to be a request that is for a commercial use. Requesters must reasonably describe the records sought.

(d) *All other requesters.* ABMC shall charge requesters who do not fit into any of the categories above fees that recover the full reasonable direct cost of searching for and reproducing records that are responsive to the request, except that the first 100 pages of reproduction and the first 2 hours of search time shall be furnished without charge. Moreover, requests for records about the requesters filed in ABMC's systems of records will continue to be treated under the fee provisions of the Privacy Act of 1974 which permit fees only for reproduction. Requesters must reasonably describe the records sought.

#### § 404.9 Miscellaneous fee provisions.

(a) *Charging interest—notice and rate.* ABMC may begin assessing interest charges on an unpaid bill starting on the 31st day following the day on which the billing was sent. The fact that the fee has been received by ABMC within the 30-day grace period, even if not processed, will suffice to stay the accrual of interest. Interest will be at the rate prescribed in section 3717 of Title 31 of the United States Code and will accrue from the date of the billing.

(b) *Charges for unsuccessful search.* ABMC may assess charges for time spent searching, even if it fails to locate the records or if records located are determined to be exempt from disclosure. If ABMC estimates that search charges are likely to exceed \$25, it shall notify the requester of the estimated amount of fees, unless the requester has indicated in advance his willingness to pay fees as high as those anticipated. Such a notice shall offer the requester the opportunity to confer with agency personnel with the object of reformulating the request to meet his or her needs at a lower cost.

(c) *Aggregating requests.* A requester may not file multiple requests at the same time, each seeking portions of a document or documents, solely in order to avoid payment of fees. When ABMC reasonably believes that a requester, or a group of requestors acting in concert, has submitted requests that constitute a single request, involving clearly related matters, ABMC may aggregate those requests and charge accordingly. One element to be considered in determining whether a belief would be reasonable is the time period over which the requests have occurred.

(d) *Advance payments.* ABMC may not require a requester to make an advance payment, *i.e.*, payment before work is commenced or continued on a request, unless:

(1) ABMC estimates or determines that allowable charges that a requester may be required to pay are likely to exceed \$250. Then, ABMC will notify the requester of the likely cost and obtain satisfactory assurance of full payment where the requester has a history of prompt payment of FOIA fees, or require an advance payment of an amount up to the full estimated

**§ 404.10**

**36 CFR Ch. IV (7-1-03 Edition)**

charges in the case of requesters with no history of payment; or

(2) A requester has previously failed to pay a fee charged in a timely fashion (*i.e.*, within 30 days of the date of the billing). Then, ABMC may require the requester to pay the full amount owed plus any applicable interest as provided above or demonstrate that he or she has, in fact, paid the fee, and to make an advance payment of the full amount of the estimated fee before the agency begins to process a new request or a pending request from that requester.

(3) When ABMC acts under paragraph (d)(1) or (2) of this section, the administrative time limits prescribed in the FOIA, 5 U.S.C. 552(a)(6) (*i.e.*, 20 working days from receipt of initial requests and 20 working days from receipt of appeals from initial denial, plus permissible extensions of these time limits), will begin only after ABMC has received fee payments described in paragraphs (d)(1) and (2) of this section. Effect of the Debt Collection Act of 1982 (Pub. L. 97-365). ABMC should comply with provisions of the Debt Collection Act, including disclosure to consumer reporting agencies and use of collection agencies, where appropriate, to encourage repayment.

**§ 404.10 Waiver or reduction of charges.**

Fees otherwise chargeable in connection with a request for disclosure of a record shall be waived or reduced where it is determined that disclosure is in the public interest because it is likely to contribute significantly to public understanding of the operations or activities of the Government and is not primarily in the commercial interest of the requester.

**PART 406—ENFORCEMENT OF NONDISCRIMINATION ON THE BASIS OF HANDICAP IN PROGRAMS OR ACTIVITIES CONDUCTED BY AMERICAN BATTLE MONUMENTS COMMISSION**

- Sec.
- 406.101 Purpose.
- 406.102 Application.
- 406.103 Definitions.
- 406.104-406.109 [Reserved]
- 406.110 Self-evaluation.

- 406.111 Notice.
- 406.112-406.129 [Reserved]
- 406.130 General prohibitions against discrimination.
- 406.131-406.139 [Reserved]
- 406.140 Employment.
- 406.141-406.148 [Reserved]
- 406.149 Program accessibility: Discrimination prohibited.
- 406.150 Program accessibility: Existing facilities.
- 406.151 Program accessibility: New construction and alterations.
- 406.152-406.159 [Reserved]
- 406.160 Communications.
- 406.161-406.169 [Reserved]
- 406.170 Compliance procedures.
- 406.171-406.999 [Reserved]

AUTHORITY: 29 U.S.C. 794.

SOURCE: 51 FR 4577, Feb. 5, 1986, unless otherwise noted.

**§ 406.101 Purpose.**

This part effectuates section 119 of the Rehabilitation, Comprehensive Services, and Developmental Disabilities Amendments of 1978, which amended section 504 of the Rehabilitation Act of 1973 to prohibit discrimination on the basis of handicap in programs or activities conducted by Executive agencies or the United States Postal Service.

**§ 406.102 Application.**

This part applies to all programs or activities conducted by the agency.

**§ 406.103 Definitions.**

For purposes of this part, the term—*Assistant Attorney General* means the Assistant Attorney General, Civil Rights Division, United States Department of Justice.

*Auxiliary aids* means services or devices that enable persons with impaired sensory, manual, or speaking skills to have an equal opportunity to participate in, and enjoy the benefits of, programs or activities conducted by the agency. For example, auxiliary aids useful for persons with impaired vision include readers, Brailled materials, audio recordings, telecommunications devices and other similar services and devices. Auxiliary aids useful for persons with impaired hearing include telephone handset amplifiers, telephones compatible with hearing aids, telecommunication devices for deaf persons (TDD's), interpreters,

notetakers, written materials, and other similar services and devices.

*Complete complaint* means a written statement that contains the complainant's name and address and describes the agency's alleged discriminatory action in sufficient detail to inform the agency of the nature and date of the alleged violation of section 504. It shall be signed by the complainant or by someone authorized to do so on his or her behalf. Complaints filed on behalf of classes or third parties shall describe or identify (by name, if possible) the alleged victims of discrimination.

*Facility* means all or any portion of buildings, structures, equipment, roads, walks, parking lots, rolling stock or other conveyances, or other real or personal property.

*Handicapped person* means any person who has a physical or mental impairment that substantially limits one or more major life activities, has a record of such an impairment, or is regarded as having such an impairment.

As used in this definition, the phrase:

(1) *Physical or mental impairment* includes—

(i) Any physiological disorder or condition, cosmetic disfigurement, or anatomical loss affecting one or more of the following body systems: Neurological; musculoskeletal; special sense organs; respiratory, including speech organs; cardiovascular; reproductive; digestive; genitourinary; hemic and lymphatic; skin; and endocrine; or

(ii) Any mental or psychological disorder, such as mental retardation, organic brain syndrome, emotional or mental illness, and specific learning disabilities. The term *physical or mental impairment* includes, but is not limited to, such diseases and conditions as orthopedic, visual, speech, and hearing impairments, cerebral palsy, epilepsy, muscular dystrophy, multiple sclerosis, cancer, heart disease, diabetes, mental retardation, emotional illness, and drug addition and alcoholism.

(2) *Major life activities* includes functions such as caring for one's self, performing manual tasks, walking, seeing, hearing, speaking, breathing, learning, and working.

(3) *Has a record of such an impairment* means has a history of, or has been misclassified as having, a mental or

physical impairment that substantially limits one or more major life activities.

(4) *Is regarded as having an impairment* means—

(i) Has a physical or mental impairment that does not substantially limit major life activities but is treated by the agency as constituting such a limitation;

(ii) Has a physical or mental impairment that substantially limits major life activities only as a result of the attitudes of others toward such impairment; or

(iii) Has none of the impairments defined in subparagraph (1) of this definition but is treated by the agency as having such an impairment.

*Qualified handicapped person* means—

(1) With respect to any agency program or activity under which a person is required to perform services or to achieve a level of accomplishment, a handicapped person who meets the essential eligibility requirements and who can achieve the purpose of the program or activity without modifications in the program or activity that the agency can demonstrate would result in a fundamental alteration in its nature; or

(2) With respect to any other program or activity, a handicapped person who meets the essential eligibility requirements for participation in, or receipt of benefits from, that program or activity.

(3) *Qualified handicapped person* is defined for purposes of employment in 29 CFR 1613.702(f), which is made applicable to this part by § 406.140.

*Section 504* means section 504 of the Rehabilitation Act of 1973 (Pub. L. 93-112, 87 Stat. 394 (29 U.S.C. 794)), as amended by the Rehabilitation Act Amendments of 1974 (Pub. L. 93-516, 88 Stat. 1617), and the Rehabilitation, Comprehensive Services, and Developmental Disabilities Amendments of 1978 (Pub. L. 95-602, 92 Stat. 2955). As used in this part, section 504 applies only to programs or activities conducted by Executive agencies and not to federally assisted programs.

[51 FR 4577, Feb. 5, 1986; 51 FR 7543, Mar. 5, 1986]

§§ 406.104–406.109 [Reserved]

§ 406.110 Self-evaluation.

(a) The agency shall, by April 9, 1987, evaluate its current policies and practices, and the effects thereof, that do not or may not meet the requirements of this part, and, to the extent modification of any such policies and practices is required, the agency shall proceed to make the necessary modifications.

(b) The agency shall provide an opportunity to interested persons, including handicapped persons or organizations representing handicapped persons, to participate in the self-evaluation process by submitting comments (both oral and written).

(c) The agency shall, until three years following the completion of the self-evaluation, maintain on file and make available for public inspections:

- (1) A description of areas examined and any problems identified, and
- (2) A description of any modifications made.

§ 406.111 Notice.

The agency shall make available to employees, applicants, participants, beneficiaries, and other interested persons such information regarding the provisions of this part and its applicability to the programs or activities conducted by the agency, and make such information available to them in such manner as the head of the agency finds necessary to apprise such persons of the protections against discrimination assured them by section 504 and this regulation.

§§ 406.112–406.129 [Reserved]

§ 406.130 General prohibitions against discrimination.

(a) No qualified handicapped person shall, on the basis of handicap, be excluded from participation in, be denied the benefits of, or otherwise be subjected to discrimination under any program or activity conducted by the agency.

(b)(1) The agency, in providing any aid, benefit, or service, may not, directly or through contractual, licensing, or other arrangements, on the basis of handicap—

(i) Deny a qualified handicapped person the opportunity to participate in or benefit from the aid, benefit, or service;

(ii) Afford a qualified handicapped person an opportunity to participate in or benefit from the aid, benefit, or service that is not equal to that afforded others;

(iii) Provide a qualified handicapped person with an aid, benefit, or service that is not as effective in affording equal opportunity to obtain the same result, to gain the same benefit, or to reach the same level of achievement as that provided to others;

(iv) Provide different or separate aid, benefits, or services to handicapped persons or to any class of handicapped persons than is provided to others unless such action is necessary to provide qualified handicapped persons with aid, benefits, or services that are as effective as those provided to others;

(v) Deny a qualified handicapped person the opportunity to participate as a member of planning or advisory boards; or

(vi) Otherwise limit a qualified handicapped person in the enjoyment of any right, privilege, advantage, or opportunity enjoyed by others receiving the aid, benefit, or service.

(2) The agency may not deny a qualified handicapped person the opportunity to participate in programs or activities that are not separate or different, despite the existence of permissibly separate or different programs or activities.

(3) The agency may not, directly or through contractual or other arrangements, utilize criteria or methods of administration the purpose or effect of which would—

(i) Subject qualified handicapped persons to discrimination on the basis of handicap; or

(ii) Defeat or substantially impair accomplishment of the objectives of a program or activity with respect to handicapped persons.

(4) The agency may not, in determining the site or location of a facility, make selections the purpose or effect of which would—

(i) Exclude handicapped persons from, deny them the benefits of, or otherwise subject them to discrimination

under any program or activity conducted by the agency; or

(ii) Defeat or substantially impair the accomplishment of the objectives of a program or activity with respect to handicapped persons.

(5) The agency, in the selection of procurement contractors, may not use criteria that subject qualified handicapped persons to discrimination on the basis of handicap.

(c) The exclusion of nonhandicapped persons from the benefits of a program limited by Federal statute or Executive order to handicapped persons or the exclusion of a specific class of handicapped persons from a program limited by Federal statute or Executive order to a different class of handicapped persons is not prohibited by this part.

(d) The agency shall administer programs and activities in the most integrated setting appropriate to the needs of qualified handicapped persons.

**§§ 406.131–406.139 [Reserved]**

**§ 406.140 Employment.**

No qualified handicapped person shall, on the basis of handicap, be subjected to discrimination in employment under any program or activity conducted by the agency. The definitions, requirements, and procedures of section 501 of the Rehabilitation Act of 1973 (29 U.S.C. 791), as established by the Equal Employment Opportunity Commission in 29 CFR part 1613, shall apply to employment in federally conducted programs or activities.

**§§ 406.141–406.148 [Reserved]**

**§ 406.149 Program accessibility: Discrimination prohibited.**

Except as otherwise provided in § 406.150, no qualified handicapped person shall, because the agency's facilities are inaccessible to or unusable by handicapped persons, be denied the benefits of, be excluded from participation in, or otherwise be subjected to discrimination under any program or activity conducted by the agency.

**§ 406.150 Program accessibility: Existing facilities.**

(a) *General.* The agency shall operate each program or activity so that the

program or activity, when viewed in its entirety, is readily accessible to and usable by handicapped persons. This paragraph does not—

(1) Necessarily require the agency to make each of its existing facilities accessible to and usable by handicapped persons; or

(2) Require the agency to take any action that it can demonstrate would result in a fundamental alteration in the nature of a program or activity or in undue financial and administrative burdens. In those circumstances where agency personnel believe that the proposed action would fundamentally alter the program or activity or would result in undue financial and administrative burdens, the agency has the burden of proving that compliance with § 406.150(a) would result in such alteration or burdens. The decision that compliance would result in such alteration or burdens must be made by the agency head or his or her designee after considering all agency resources available for use in the funding and operation of the conducted program or activity, and must be accompanied by a written statement of the reasons for reaching that conclusion. If an action would result in such an alteration or such burdens, the agency shall take any other action that would not result in such an alteration or such burdens but would nevertheless ensure that handicapped persons receive the benefits and services of the program or activity.

(b) *Methods.* The agency may comply with the requirements of this section through such means as redesign of equipment, reassignment of services to accessible buildings, assignment of aides to beneficiaries, home visits, delivery of services at alternate accessible sites, alteration of existing facilities and construction of new facilities, use of accessible rolling stock, or any other methods that result in making its programs or activities readily accessible to and usable by handicapped persons. The agency is not required to make structural changes in existing facilities where other methods are effective in achieving compliance with this section. The agency, in making alterations to existing buildings, shall meet

## § 406.151

accessibility requirements to the extent compelled by the Architectural Barriers Act of 1968, as amended (42 U.S.C. 4151-4157), and any regulations implementing it. In choosing among available methods for meeting the requirements of this section, the agency shall give priority to those methods that offer programs and activities to qualified handicapped persons in the most integrated setting appropriate.

(c) *Time period for compliance.* The agency shall comply with the obligations established under this section by June 6, 1986, except that where structural changes in facilities are undertaken, such changes shall be made by April 7, 1989, but in any event as expeditiously as possible.

(d) *Transition plan.* In the event that structural changes to facilities will be undertaken to achieve program accessibility, the agency shall develop, by October 7, 1986, a transition plan setting forth the steps necessary to complete such changes. The agency shall provide an opportunity to interested persons, including handicapped persons or organizations representing handicapped persons, to participate in the development of the transition plan by submitting comments (both oral and written). A copy of the transition plan shall be made available for public inspection. The plan shall, at a minimum—

(1) Identify physical obstacles in the agency's facilities that limit the accessibility of its programs or activities to handicapped persons;

(2) Describe in detail the methods that will be used to make the facilities accessible;

(3) Specify the schedule for taking the steps necessary to achieve compliance with this section and, if the time period of the transition plan is longer than one year, identify steps that will be taken during each year of the transition period; and

(4) Indicate the official responsible for implementation of the plan.

[51 FR 4577, Feb. 5, 1986; 51 FR 7543, Mar. 5, 1986]

### § 406.151 Program accessibility: New construction and alterations.

Each building or part of a building that is constructed or altered by, on

## 36 CFR Ch. IV (7-1-03 Edition)

behalf of, or for the use of the agency shall be designed, constructed, or altered so as to be readily accessible to and usable by handicapped persons. The definitions, requirements, and standards of the Architectural Barriers Act (42 U.S.C. 4151-4157), as established in 41 CFR 101-19.600 to 101-19.607, apply to buildings covered by this section.

### §§ 406.152-406.159 [Reserved]

### § 406.160 Communications.

(a) The agency shall take appropriate steps to ensure effective communication with applicants, participants, personnel of other Federal entities, and members of the public.

(1) The agency shall furnish appropriate auxiliary aids where necessary to afford a handicapped person an equal opportunity to participate in, and enjoy the benefits of, a program or activity conducted by the agency.

(i) In determining what type of auxiliary aid is necessary, the agency shall give primary consideration to the requests of the handicapped person.

(ii) The agency need not provide individually prescribed devices, readers for personal use or study, or other devices of a personal nature.

(2) Where the agency communicates with applicants and beneficiaries by telephone, telecommunication devices for deaf persons (TDD's) or equally effective telecommunication systems shall be used.

(b) The agency shall ensure that interested persons, including persons with impaired vision or hearing, can obtain information as to the existence and location of accessible services, activities, and facilities.

(c) The agency shall provide signage at a primary entrance to each of its inaccessible facilities, directing users to a location at which they can obtain information about accessible facilities. The international symbol for accessibility shall be used at each primary entrance of an accessible facility.

(d) This section does not require the agency to take any action that it can demonstrate would result in a fundamental alteration in the nature of a program or activity or in undue financial and administrative burdens. In



## American Battle Monuments Commission

## § 406.170

those circumstances where agency personnel believe that the proposed action would fundamentally alter the program or activity or would result in undue financial and administrative burdens, the agency has the burden of proving that compliance with § 406.160 would result in such alteration or burdens. The decision that compliance would result in such alteration or burdens must be made by the agency head or his or her designee after considering all agency resources available for use in the funding and operation of the conducted program or activity, and must be accompanied by a written statement of the reasons for reaching that conclusion. If an action required to comply with this section would result in such an alteration or such burdens, the agency shall take any other action that would not result in such an alteration or such burdens but would nevertheless ensure that, to the maximum extent possible, handicapped persons receive the benefits and services of the program or activity.

### §§ 406.161–406.169 [Reserved]

#### § 406.170 Compliance procedures.

(a) Except as provided in paragraph (b) of this section, this section applies to all allegations of discrimination on the basis of handicap in programs or activities conducted by the agency.

(b) The agency shall process complaints alleging violations of section 504 with respect to employment according to the procedures established by the Equal Employment Opportunity Commission in 29 CFR part 1613 pursuant to section 501 of the Rehabilitation Act of 1973 (29 U.S.C. 791).

(c) The Director, Personnel and Administration shall be responsible for coordinating implementation of this section. Complaints may be sent to the Director, Personnel and Administration, American Battle Monuments Commission, Room 5127, Pulaski Building, 20 Massachusetts Ave., NW., Washington, DC 20314.

(d) The agency shall accept and investigate all complete complaints for which it has jurisdiction. All complete complaints must be filed within 180 days of the alleged act of discrimination. The agency may extend this time period for good cause.

(e) If the agency receives a complaint over which it does not have jurisdiction, it shall promptly notify the complainant and shall make reasonable efforts to refer the complaint to the appropriate government entity.

(f) The agency shall notify the Architectural and Transportation Barriers Compliance Board upon receipt of any complaint alleging that a building or facility that is subject to the Architectural Barriers Act of 1968, as amended (42 U.S.C. 4151–4157), or section 502 of the Rehabilitation Act of 1973, as amended (29 U.S.C. 792), is not readily accessible to and usable by handicapped persons.

(g) Within 180 days of the receipt of a complete complaint for which it has jurisdiction, the agency shall notify the complainant of the results of the investigation in a letter containing—

(1) Findings of fact and conclusions of law;

(2) A description of a remedy for each violation found;

**§§ 406.171–406.999**

(3) A notice of the right to appeal.

(h) Appeals of the findings of fact and conclusions of law or remedies must be filed by the complainant within 90 days of receipt from the agency of the letter required by §406.170(g). The agency may extend this time for good cause.

(i) Timely appeals shall be accepted and processed by the head of the agency.

(j) The head of the agency shall notify the complainant of the results of the appeal within 60 days of the receipt of the request. If the head of the agency determines that additional information is needed from the complainant, he or she shall have 60 days from the date of receipt of the additional infor-

**36 CFR Ch. IV (7–1–03 Edition)**

mation to make his or her determination on the appeal.

(k) The time limits cited in paragraphs (g) and (j) of this section may be extended with the permission of the Assistant Attorney General.

(l) The agency may delegate its authority for conducting complaint investigations to other Federal agencies, except that the authority for making the final determination may not be delegated to another agency.

[51 FR 4577, Feb. 5, 1986, as amended at 51 FR 4577, Feb. 5, 1986]

**§§ 406.171–406.999 [Reserved]**

**PARTS 407–499 [RESERVED]**

## CHAPTER V—SMITHSONIAN INSTITUTION

---

<i>Part</i>		<i>Page</i>
504	Rules and regulations governing Smithsonian Institution buildings and grounds .....	55
520	Rules and regulations governing the buildings and grounds of the National Zoological Park of the Smithsonian Institution .....	57
530	Claims against the Smithsonian Institution including the National Gallery of Art, the John F. Kennedy Center for the Performing Arts and the Woodrow Wilson International Center for Scholars .....	59
531-599	[Reserved]	



**PART 504—RULES AND REGULATIONS GOVERNING SMITHSONIAN INSTITUTION BUILDINGS AND GROUNDS**

Sec.

- 504.1 General.
- 504.2 Recording presence.
- 504.3 Preservation of property.
- 504.4 Conformity with signs and emergency directions.
- 504.5 Nuisances.
- 504.6 Gambling.
- 504.7 Intoxicating beverages and narcotics.
- 504.8 Soliciting, vending, debt collection, and distribution of handbills.
- 504.9 Placards, signs, banners and flags.
- 504.10 Dogs and other animals.
- 504.11 Photographs for news, advertising, or commercial purposes.
- 504.12 Items to be checked.
- 504.13 Vehicular and pedestrian traffic.
- 504.14 Weapons and explosives.
- 504.15 Nondiscrimination.
- 504.16 Penalties.

AUTHORITY: Secs. 1-9, 65 Stat. 634, as amended, secs. 1-4, 78 Stat. 365; 40 U.S.C. 193n-193w.

SOURCE: 33 FR 6656, May 1, 1968, unless otherwise noted.

**§ 504.1 General.**

These rules and regulations apply to all buildings and grounds of the Smithsonian Institution, as defined in section 3, 78 Stat. 366; 40 U.S.C. 193v(1) (A) and (C), and to all persons entering in or on such buildings and grounds, hereinafter referred to as the premises

**§ 504.2 Recording presence.**

Except as otherwise ordered, Smithsonian buildings shall be closed to the public after normal visiting hours. Such buildings, or portions thereof, shall also be closed to the public in emergency situations and at such other times as may be necessary for the orderly conduct of business. Whenever the buildings are closed to the public for any reason, visitors will immediately leave the premises upon being requested by a guard or other authorized individuals. Admission to such premises during periods when closed to the public will be limited to authorized individuals who will be required to register and identify themselves when re-

quested by guards or other authorized individuals.

**§ 504.3 Preservation of property.**

It is unlawful willfully to destroy, damage, or remove property or any part thereof. Any parcels, portfolios, bags, or containers of any kind may be required to be opened and the contents identified prior to removal from the premises. In order to remove any property from the premises, a properly completed property pass signed by an authorized official of the Smithsonian Institution may be required prior to removal.

**§ 504.4 Conformity with signs and emergency directions.**

Persons in or on the premises shall comply with official signs of a prohibitory or directory nature and with the directions of authorized individuals.

**§ 504.5 Nuisances.**

The use of loud, abusive, or otherwise improper language; unwarranted loitering, sleeping or assembly; the creation of any hazard to persons or things; improper disposal of rubbish; spitting, prurient prying; the commission of any obscene or indecent act, or any other unseemly or disorderly conduct on the premises; throwing articles of any kind from or within a building; or climbing upon any part of a building is prohibited.

**§ 504.6 Gambling.**

Participating in games for money or other personal property or the operation of gambling devices, the conduct of a lottery or pool, or the selling or purchasing of numbers tickets in or on the premises is prohibited.

**§ 504.7 Intoxicating beverages and narcotics.**

Entering the premises or the operating of a motor vehicle thereon by a person under the influence of any intoxicating beverage or narcotic drug or the use of such drug in or on the premises is prohibited. Consumption of intoxicating beverages on the premises is prohibited unless officially authorized.

## § 504.8

### § 504.8 Soliciting, vending, debt collection, and distribution of handbills

The soliciting of alms and contributions, commercial soliciting and vending of all kinds, the display or distribution of commercial advertising, or the collecting of private debts, in or on the premises is prohibited. This rule does not apply to national or local drives for funds for welfare, health, and other purposes sponsored or approved by the Smithsonian Institution concessions, or personal notices posted by employees on authorized bulletin boards. Distribution of material such as pamphlets, handbills, and flyers is prohibited without prior approval of authorized individuals.

### § 504.9 Placards, signs, banners and flags.

The displaying or carrying of placards, signs, banners, or flags is prohibited unless officially authorized.

### § 504.10 Dogs and other animals.

Dogs and other animals, except seeing-eye dogs, shall not be brought upon the premises for other than official purposes.

### § 504.11 Photographs for news, advertising, or commercial purposes.

No photographs for advertising or any other commercial purpose may be taken on the premises unless officially authorized.

### § 504.12 Items to be checked.

Umbrellas, canes (not needed to assist in walking), or other objects capable of inflicting damage to property or exhibits may be required to be checked in buildings where checking facilities are provided.

### § 504.13 Vehicular and pedestrian traffic.

(a) Drivers of all vehicles in or on the premises shall drive in a careful and safe manner at all times and shall comply with the signals and directions of the guards and all posted traffic signs.

(b) The blocking of entrances, driveways, walks, loading platforms, or fire hydrants in or on property is prohibited. Parking without authority, or

## 36 CFR Ch. V (7-1-03 Edition)

parking in unauthorized locations or in locations reserved for other persons or contrary to the direction of posted signs, is prohibited. This paragraph may be supplemented from time to time by the issuance and posting of such additional traffic and parking directives as may be required, and such directives shall have the same force and effect as if made a part thereof.

### § 504.14 Weapons and explosives.

No person while on the premises shall carry firearms, other dangerous or deadly weapons, or explosives, either openly or concealed, except for official purposes.

### § 504.15 Nondiscrimination.

There shall be no discrimination by segregation or otherwise against any person or persons because of race, religion, color, or national origin in furnishing or by refusing to furnish to such person or persons the use of any facility of a public nature, including all services, privileges, accommodations, and activities provided thereby on the premises.

### § 504.16 Penalties.

Section 6 of the Smithsonian Institution Special Policing Statute, Act of October 24, 1951, 65 Stat. 635, 40 U.S.C. 193(s) states that:

Whoever violates any provision of sections 193o-193q of this Title, or any regulation prescribed under section 193r of this Title, shall be fined not more than \$100 or imprisoned not more than sixty days, or both, prosecution for such offenses to be had in the District of Columbia Court of General Sessions, upon information by the U.S. attorney or any of his assistants: *Provided*, That in any case where, in the commission of such offense, property is damaged in an amount exceeding \$100, the amount of the fine for the offense may be not more than \$5,000, the period of imprisonment for the offense may be not more than 5 years and prosecution shall be had in the U.S. District Court for the District of Columbia by indictment, or if the defendant, after he has been advised of the nature of the charge and of his rights, waives in open court prosecution by indictment, by information by the U.S. attorney or any of his assistants.

**PART 520—RULES AND REGULATIONS GOVERNING THE BUILDINGS AND GROUNDS OF THE NATIONAL ZOOLOGICAL PARK OF THE SMITHSONIAN INSTITUTION**

Sec.

- 520.1 General.
- 520.2 Recording presence.
- 520.3 Preservation of property.
- 520.4 Protection of zoo animals.
- 520.5 Conformity with signs and emergency directions.
- 520.6 Nuisances.
- 520.7 Gambling.
- 520.8 Intoxicating beverages and narcotics.
- 520.9 Soliciting, vending, debt collection, and distribution of handbills.
- 520.10 Placards, signs, banners, and flags.
- 520.11 Dogs and other animals.
- 520.12 Photographs for news, advertising, or commercial purposes.
- 520.13 Items to be checked.
- 520.14 Vehicular and pedestrian traffic.
- 520.15 Weapons and explosives.
- 520.16 Nondiscrimination.
- 520.17 Lost and found.
- 520.18 Penalties.

AUTHORITY: Secs. 1-9, 65 Stat. 634, as amended, secs. 1-4, 78 Stat. 365; 40 U.S.C. 193n-193w.

SOURCE: 33 FR 17175, Nov. 20, 1968, unless otherwise noted.

**§ 520.1 General.**

The rules and regulations in this part apply to all buildings and grounds of the National Zoological Park of the Smithsonian Institution, as defined in sec. 3, 78 Stat. 366; 40 U.S.C. 193v(1)(B), and to all persons entering in or on such buildings and grounds, hereinafter referred to as the premises.

**§ 520.2 Recording presence.**

Except as otherwise ordered, National Zoological Park buildings and grounds shall be closed to the public after posted visiting hours. Such buildings and grounds, or portions thereof, shall be also closed to the public in emergency situations and at such other times as may be necessary for the orderly conduct of business. Whenever the buildings and grounds or portions thereof are closed to the public for any reason, visitors will immediately leave the premises upon being requested by a police officer or other authorized indi-

vidual. Admission to such premises during periods when closed to the public will be limited to authorized individuals who will be required to register and identify themselves when requested by police officers or other authorized individuals.

**§ 520.3 Preservation of property.**

It is unlawful willfully to destroy, damage, or remove property or any part thereof. Any parcels, portfolios, bags, or containers of any kind may be required to be opened and the contents identified prior to removal from the premises. In order to remove any property from the premises, a properly completed property pass signed by an authorized official of the National Zoological Park may be required prior to removal.

**§ 520.4 Protection of zoo animals.**

Except for official purposes, no person shall:

- (a) Kill, injure, or disturb any exhibit or research animal by any means except to secure personal safety;
- (b) Pet, attempt to pet, handle, move, or remove exhibit or research animals;
- (c) Feed exhibit or research animals, except in strict accordance with authorized signs;
- (d) Catch, attempt to catch, trap, remove, or kill any free roaming animals inhabiting the premises;
- (e) Go over, under, between, or otherwise cross any guardrail, fence, moat, wall, or any other safety barrier; or to seat, stand, or hold children over any of the above-mentioned barriers;
- (f) Throw or toss rocks, or any other missiles into, from, or while on premises;
- (g) Bring strollers, baby carriages, or other conveyances, except wheel chairs, into exhibit buildings and public restrooms;
- (h) Engage in ball games, or any athletic activity, except in places as may be officially designated for such purposes;
- (i) Smoke or carry lighted cigarettes, cigars, or pipes into exhibit buildings, or to have a fire of any kind on the premises; or
- (j) Damage, deface, pick, or remove any herb, shrub, bush, tree, or turf, or portion thereof, on the premises.

**§ 520.5**

**§ 520.5 Conformity with signs and emergency directions.**

Persons in or on the premises shall comply with official signs of a prohibitory or directory nature and with the directions of authorized individuals.

**§ 520.6 Nuisances.**

The use of loud, abusive, or otherwise improper language; unwarranted loitering, sleeping or assembly; the creation of any hazard to persons or things; improper disposal of rubbish; spitting; prurient prying; the commission of any obscene or indecent act, or any other unseemly or disorderly conduct on the premises; throwing articles of any kind on the premises, or climbing upon any part of the building is prohibited.

**§ 520.7 Gambling.**

Participating in games for money or other personal property or the operation of gambling devices, the conduct of a lottery or pool, or the selling or purchasing of numbers tickets in or on the premises is prohibited.

**§ 520.8 Intoxicating beverages and narcotics.**

Entering the premises or the operation of a motor vehicle thereon by a person under the influence of any intoxicating beverage or narcotic drug or the use of such drug in or on the premises is prohibited. Consumption of intoxicating beverages on the premises is prohibited, unless officially authorized.

**§ 520.9 Soliciting, vending, debt collection, and distribution of handbills.**

The soliciting of alms and contributions, commercial soliciting and vending of all kinds, the display or distribution of commercial advertising or the collecting of private debts, in or on the premises is prohibited. This rule does not apply to national or local drives for funds for welfare, health, and other purposes sponsored or approved by the National Zoological Park, concessions, or personal notices posted by employees on authorized bulletin boards. Distribution of material such as pamphlets, handbills, and flyers is prohibited without prior approval of authorized individuals.

**36 CFR Ch. V (7-1-03 Edition)**

**§ 520.10 Placards, signs, banners, and flags.**

The displaying or carrying of placards, signs, banners, or flags is prohibited unless officially authorized.

**§ 520.11 Dogs and other animals.**

Dogs and other animals, except seeing-eye dogs, shall not be brought upon the premises for other than official purposes unless confined to automobiles.

**§ 520.12 Photographs for news, advertising, or commercial purposes.**

No photographs for advertising or any other commercial purpose may be taken on the premises unless officially authorized.

**§ 520.13 Items to be checked.**

Umbrellas, canes (not needed to assist in walking), or other objects capable of inflicting damage to property or exhibits may be required to be checked at the police station where checking facilities are provided.

**§ 520.14 Vehicular and pedestrian traffic.**

(a) Drivers of all vehicles in or on the premises shall drive in a careful and safe manner at all times and shall comply with the signals and directions of the police and all posted traffic signs.

(b) The blocking of entrances, driveways, walks, loading platforms, or fire hydrants in or on property is prohibited. Parking without authority, or parking in unauthorized locations or in locations reserved for other persons or contrary to the direction of posted signs, is prohibited. This paragraph may be supplemented from time to time by the issuance and posting of such additional traffic and parking directives as may be required, and such directives shall have the same force and effect as if made a part thereof.

**§ 520.15 Weapons and explosives.**

No person while on the premises shall carry firearms, other dangerous or deadly weapons, or explosives, either openly or concealed, except for official purposes, nor shall any person discharge or set off any firework or explosive of any nature on the premises.



## Smithsonian Institution

## § 530.1

### § 520.16 Nondiscrimination.

There shall be no discrimination by segregation or otherwise against any person or persons because of race, religion, color, or national origin in furnishing or by refusing to furnish to such person or persons the use of any facility of a public nature, including all services, privileges, accommodations, and activities provided thereby on the premises.

### § 520.17 Lost and found.

(a) Lost articles or money which are found in areas covered by this part shall be immediately referred to the police station. Proper records shall be kept at Police Headquarters of the receipt and disposition of such articles. If an article or money found on park areas and referred to Zoo Police Headquarters is not claimed by the owner within a period of 60 days, it shall be returned to the finder and appropriate receipt obtained; except that in the case of National Zoological Park employees, articles or money turned in which are not claimed by the owner within 60 days shall be considered as abandoned to the Smithsonian Institution. Such articles or money shall be transferred to the Treasurer of the Smithsonian Institution, who shall make suitable disposition of articles and remit all proceeds of such disposition and all unclaimed money into the unrestricted funds of the Smithsonian Institution.

(b) The abandonment of any personal property in any of the park areas is prohibited.

### § 520.18 Penalties.

Section 6 of the Smithsonian Institution Special Policing Statute, Act of October 24, 1951, 65 Stat. 635, 40 U.S.C. 193 (s) states that:

Whoever violates any provision of sections 193o-193q of this title, or any regulation prescribed under section 193r of this Title, shall be fined not more than \$100 or imprisoned not more than 60 days, or both, prosecution for such offenses to be had in the District of Columbia Court of General Sessions, upon information by the United States attorney or any of his assistants: *Provided*, That in any case where, in the commission of such offense, property is damaged in an amount exceeding \$100, the amount of the fine for the

offense may be not more than \$5,000, the period of imprisonment for the offense may be not more than 5 years and prosecution shall be had in the U.S. District Court for the District of Columbia by indictment, or if the defendant, after he has been advised of the nature of the charge and of his rights, waives in open court prosecution by indictment, by information by the U.S. attorney or any of his assistants.

## PART 530—CLAIMS AGAINST THE SMITHSONIAN INSTITUTION INCLUDING THE NATIONAL GALLERY OF ART, THE JOHN F. KENNEDY CENTER FOR THE PERFORMING ARTS AND THE WOODROW WILSON INTERNATIONAL CENTER FOR SCHOLARS

AUTHORITY: 20 U.S.C. 41, *et seq.*

### § 530.1 Tort claims.

The Smithsonian Institution (which encompasses the National Gallery of Art, the John F. Kennedy Center for the Performing Arts and the Woodrow Wilson International Center for Scholars) falls within the purview of the Federal Tort Claims Act. Internal procedures for implementing the Act follow the current general guidance issued by the U.S. Department of Justice in 28 CFR part 14. Information on specific claims procedures can be obtained as follows:

(a) Smithsonian Institution: Office of the General Counsel, Smithsonian Institution, Washington, DC 20560.

(b) National Gallery of Art: Administrator, National Gallery of Art, Washington, DC 20565.

(c) John F. Kennedy Center for the Performing Arts: Director of Operations, John F. Kennedy Center for the Performing Arts, Washington, DC 20566.

(d) Woodrow Wilson International Center for Scholars: Assistant Director for Administration, Woodrow Wilson International Center for Scholars, Smithsonian Institution, Washington, DC 20560.

[49 FR 9421, Mar. 13, 1984]

**PARTS 531-599 [RESERVED]**



CHAPTER VI [RESERVED]  
CHAPTER VII—LIBRARY OF CONGRESS

---

EDITORIAL NOTE: The regulations in this chapter VII were formerly codified in 44 CFR chapter V.

<i>Part</i>		<i>Page</i>
701	Procedures and services .....	63
702	Conduct on Library premises .....	78
703	Disclosure or production of records or information	82
704	National Film Registry of the Library of Congress	89
705	Financial Administration .....	95
706-799	[Reserved]	



## PART 701—PROCEDURES AND SERVICES

- Sec.
- 701.1 Application for employment.
  - 701.2 Access to Library buildings.
  - 701.3 Removal of materials from the Library buildings.
  - 701.4 Information about the Library.
  - 701.5 The Library's reading rooms and public use thereof.
  - 701.6 Service of the general collections.
  - 701.7 Reference and bibliographic assistance.
  - 701.8 Assignment of special research facilities.
  - 701.9 Loans of library materials.
  - 701.10 Loans of library materials for blind and other physically handicapped persons.
  - 701.11 Lending of materials from the Library for exhibition.
  - 701.12 Photoduplication service.
  - 701.13 Service of African and Middle Eastern materials.
  - 701.14 Service of Asian materials.
  - 701.15 Service of European materials.
  - 701.16 Service of folklife materials.
  - 701.17 Service of Hispanic materials.
  - 701.18 Service of legal materials.
  - 701.19 Service of local history and genealogical materials.
  - 701.20 Service of manuscript materials.
  - 701.21 Service of maps and cartographic materials.
  - 701.22 Service of microfilmed materials.
  - 701.23 Service of motion picture and television materials.
  - 701.24 Service of music materials.
  - 701.25 Service of prints and photographs.
  - 701.26 Service of rare books and special collections.
  - 701.27 Service of scientific and technical materials.
  - 701.28 Service of serial materials.
  - 701.29 Service of sound recordings.
  - 701.30 Cataloging distribution.
  - 701.31 Library of Congress publications.
  - 701.32 Offers of materials for purchase.
  - 701.33 Acquisition of library materials by non-purchase means and disposition of surplus library materials.
  - 701.34 Contracting officers.
  - 701.35 Policy on the authorized use of the Library name, seal, or logo.
  - 701.36 Use of the Seal of the Library of Congress and the Library of Congress Trust Fund Board.

AUTHORITY: 2 U.S.C. 136; 18 U.S.C. 1017.

### §701.1 Application for employment.

The Library of Congress is an Excepted Service Legislative Branch agency. As such, it has its own independent merit system, and applicants

do not need Civil Service status to apply for its positions. The Library has a wide range of clerical, technical, and professional positions (the latter being primarily oriented to library operations such as processing, cataloging, and reference, but with some positions in non-librarian occupations such as computer, subject area and research analyst specialists). The Library's Employment Office is located in Room LM-107, James Madison Building, First Street and Independence Avenue, SE., Washington, DC 20540. Information about current employment needs and the procedure for application may be obtained by either visiting this office (Monday-Friday, 8:30 a.m. to 4:30 p.m.), calling during these hours at (202) 287-JOBS, or writing to the above address. A 24-hour recording of general information is available at (202) 287-5295.

[46 FR 48660, Oct. 2, 1981]

### §701.2 Access to Library buildings.

(a) In accordance with the Library's general policy, persons other than staff members may be admitted to the Library buildings and to the various areas therein that are open to the public during the announced hours of public opening. Such persons may be admitted to other areas within the buildings and at other times only in accordance with established access regulations.

(b) Persons having legitimate business in buildings closed to the public may be admitted after identification by responsible officials in the building or by authority as evidenced by a building access pass issued by the Associate Librarian for Management.

[35 FR 10588, June 30, 1970. Redesignated at 38 FR 27049, Sept. 28, 1973, and amended at 46 FR 48660, Oct. 2, 1981]

### §701.3 Removal of materials from the Library buildings.

No material may be removed from the Library buildings without the proper stamp, pass, or other authorization as prescribed by regulations established by The Librarian of Congress. All property including, but not limited to, suitcases, briefcases, handbags, large envelopes, packages, and office

#### § 701.4

equipment may be inspected upon leaving Library buildings in order to prevent the improper removal of property belonging to the U.S. Government.

[51 FR 22073, June 18, 1986]

#### § 701.4 Information about the Library.

(a) *Information about the Library.* It is the Library's policy to furnish freely information about the Library to the media. All requests from the media, for other than generally published information and Library records, should be referred to the Public Affairs Office.

(b) *Public Affairs Office.* The Public Affairs Office shall have the principal responsibility for responding to requests for information about the Library from representatives of the media; giving advice to Library officers and staff members on public-relations and public-information matters; keeping the Librarian and other officers informed of important developments in this field; and promoting the resources and activities of the Library.

(1) During regular office hours (8:30 a.m. to 5 p.m.) telephone operators shall refer requests for information, from the media only, about the Library to the Public Affairs Office. All other requests for information shall be referred to the National Reference Service or other appropriate offices of the Library.

(2) All other Library offices and staff members who receive inquiries directly from representatives of the media for information about the Library, other than generally published information, shall refer such inquiries to the Public Affairs Office.

(3) The Public Affairs Office shall respond directly to inquiries concerning the Library, calling upon other offices to supply information to it as necessary, or shall arrange for other offices or staff members, as appropriate, to supply such information directly and report back to Public Affairs after the contact has been made. Requests for Library of Congress records, however, shall be made in accordance with 36 CFR Part 703.

(4) When the Public Affairs Office is closed (evenings, Saturdays, Sundays, and holidays), requests from the media for information about the Library shall be referred to the Public Affairs Officer

#### 36 CFR Ch. VII (7-1-03 Edition)

at his/her home. In the event that person is not available, inquiries shall be referred to the Acting Public Affairs Officer, or, in turn, a designated public affairs specialist.

(c) *Other Library Units and Staff Members.* All Other Library Units and Staff Members shall be responsible for keeping the Public Affairs Office fully and promptly informed of contacts with the press, except in those instances of routine reference inquiries; supplying the Public Affairs Office with any data it requires in order to respond to inquiries from representatives of the media; and reporting promptly to the Public Affairs Office substantive contacts with media representatives about the Library and its policies or activities.

[65 FR 11736, Mar. 6, 2000]

#### § 701.5 The Library's reading rooms and public use thereof.

(a) All members of the public wishing to use materials from the Library's collections first must obtain a User Card. The Library will issue User Cards, in accordance with established access regulations, to those persons who present a valid photo identification card containing their name and current address. The Library-issued User Card will include the name, digitized photograph, and signature of the user. It must be presented when requesting materials housed in the book stacks or other non-public areas or upon request of a Library staff member. In accordance with Library regulations which prescribe the conditions of reader registration and use of Library materials, presentation of a User Card may be required for entry into certain reading rooms. The Library will maintain the information found on the User Cards, including the digitized photograph and other pertinent information, in an automated file for collections security purposes. Access to the automated file shall be limited to only those Library staff whose official duties require access. The automated file shall be physically separated and accessible only from inside the Library.

(b) Materials in the general classified collections of the Library are serviced in the Main and Local History and Genealogy reading rooms (Thomas Jefferson Building), and the Science and

Social Science reading rooms (John Adams Building). Special collections, as explained further in subsequent sections, are serviced in the following reading rooms; Archive of Folk Culture, European, Microform, and Rare Book and Special Collections (Thomas Jefferson Building), African and Middle East and Asian (Adams Building), and Geography and Map, Law Library, Manuscript, Motion Picture and Television, Newspaper and Current Periodical, Performing Arts, Prints and Photographs, and Recorded Sound Reference Center (James Madison Memorial Building). Reference and bibliographic assistance is provided by the staff on duty in the reading rooms, to the extent necessary to supplement the reader's prior use of library resources elsewhere and/or to facilitate use of the Library's collections.

[51 FR 22073, June 18, 1986, as amended at 60 FR 34853, July 5, 1995]

**§ 701.6 Service of the general collections.**

(a) Requests for materials in the general classified collections are submitted by readers on forms provided for that purpose. Available materials so requested are located and delivered to readers by the staff. Subject to specified limitations, materials may be reserved for continued use. Access to the bookstacks is permitted only under regulations established by the Librarian of Congress.

(b) *Definitions.* (1) *Security* means administration of continuing, effective controls in areas where materials are housed for the purpose of preprocessing or processing, storage, access, or use. These controls are designed to safeguard against theft, loss, misplacement, or damage from improper use or vandalism and may vary as appropriate to the quality, monetary value, replaceability, fragility, or other special or unusual conditions relating to the materials concerned.

(2) *Library material* means:

(i) Items in all formats (including, but not limited to, books and pamphlets; documents; manuscripts; maps; microfiche, microfilms, and other microforms; motion pictures, photographs, posters, prints, drawings, videotapes, and other visual materials;

newspapers and periodicals; recorded discs, tapes, or audio/video/digital materials in other formats) either in the collections of the Library of Congress or acquired for and in process for the Library's collections;

(ii) Objects such as musical instruments, printing blocks, copper engraving plates, paintings, and scrolls, and

(iii) Control files, which are manual or automated files essential to the physical or intellectual access to Library materials, such as catalogs, computer tapes, finding aids, and shelflists. These include items that are acquired as an integral part of Library materials and are accessioned into the collections with them permanent inventory records, public catalogs, and other finding aids.

(3) *Security-controlled environment* means, but is not limited to: general and special reading rooms and research facilities where materials are issued under controlled circumstances for use of readers; the bookstacks and other storage facilities where materials are housed when not in use; and work areas where materials are held temporarily for processing.

(c) *General policy for use of Library materials.* Materials retrieved for readers' use shall be used only in assigned reading rooms or research facilities. Use elsewhere in Library buildings requires specific authorization from designated staff members of the custodial unit. Use of materials assigned to reference collections shall be in accordance with established regulations. To minimize the risk of theft, loss, or damage when the materials are removed from designated storage areas, the conditions of availability and use will vary as appropriate to the quality of materials, their monetary value, replaceability, format, physical condition, and the purpose for which they are to be circulated—reader use within the Library, exhibits, preservation, photoduplication, or loan outside the Library. Unless otherwise specified by Library regulations, and/or legal or contractual obligations, the conditions and procedures for use of materials, including duplication, either inside or outside of the Library buildings, shall be determined by or in consultation

## § 701.7

with the unit head responsible for the custody of the material used.

(1) Any material removed from the security-controlled environment of a reading room or storage area, and meeting the established criteria must be charged as an internal or external loan through the Loan Division, in accordance with established loan regulations. The security of in-process material, and special collections material not meeting the criteria of these regulations, is the responsibility of the division chief or equivalent Library officer with physical control of the material. That division shall determine whether or not a Loan Division internal charge must be created when an item is removed for use. If a Loan Division record is not created, the division shall create and maintain a local record until the item is returned.

(2) When the period of use is completed, all materials shall be returned immediately to the custodial unit to be placed in designated shelf or other locations in assigned storage areas. Charge records for the returned materials shall be removed from the charge files.

(d) *Penalties.* Readers who violate established conditions and/or procedures for using material are subject to penalties to be determined by or in consultation with the unit head responsible for the custody of the material used.

(1) When a reader violates a condition and/or procedure for using material, the division chief or head of the unit where the infraction occurred may, upon written notification, deny further access to the material, or to the unit in which it is housed, to be determined by the nature of the infraction and the material involved.

(2) Within five workdays of receipt of such notification, the reader may make a written request, including the reasons for such request to the Associate Librarian for that service unit, or his/her designee, for a reconsideration of said notification.

(3) The Associate Librarian for that service unit, or his/her designee, shall respond within five workdays of receipt of such request for reconsideration and may rescind, modify, or reaffirm said notification, as appropriate.

## 36 CFR Ch. VII (7-1-03 Edition)

(4) Repeated violations of established conditions and/or procedures for using material may result in denial of further access to the premises and further use of the Library's facilities or revocation of the reader's User Card, in accordance with established access regulations.

(5) Mutilation or theft of Library property also may result in criminal prosecution, as set forth in 18 U.S.C. 641, 1361, and 2071; and 22 D.C. Code 3106.

(6) In certain emergency situations requiring prompt action, the division chief or head of the unit where the infraction occurred immediately may deny further access to the material or unit prior to making written notification action. In such cases, the reader shall be notified, in writing, within three days of the action taken and the reasons therefor. The reader then may request reconsideration.

(7) A copy of any written notification delivered pursuant to this part shall be forwarded to the Captain, Library Police, the service unit, and the Director, Integrated Support Services, for retention.

[35 FR 10588, June 30, 1970. Redesignated at 38 FR 27049, Sept. 28, 1973, and amended at 51 FR 22073, June 18, 1986; 60 FR 34853, July 5, 1995]

### § 701.7 Reference and bibliographic assistance.

(a) Reference and bibliographic services provided in response to requests from readers and requests received by telephone and by mail are governed by policies and regulations established by the Librarian of Congress.

(b) Readers requiring reference and bibliographic assistance in the general collections and aid in the use of the catalogs may request help from the staff on duty in the general reading rooms. Requests for such assistance in special collections are referred to the appropriate specialized division and reading rooms.

(c) Reference inquiries and requests for service which cannot be satisfied by other libraries or scholarly institutions nearer the inquirer may be submitted to the Library of Congress, which will respond to them insofar and on such



## Library of Congress

## § 701.9

conditions as available staff and facilities permit.

[35 FR 10588, June 30, 1970. Redesignated at 38 FR 27049, Sept. 28, 1973, and amended at 46 FR 48661, Oct. 2, 1981]

### § 701.8 Assignment of special research facilities.

(a) *Study shelves.* Individually-assigned reserve shelves are available adjacent to several reading rooms for the use of researchers whose work requires access to the same materials over an extended period of time. Shelves are assigned to applicants for a specific period through the Research Facilities Office, Humanities and Social Sciences Division. Shelves must be renewed at designated intervals.

(b) *Study desks.* A limited number of study desks are available for the use of researchers engaged in full-time research projects involving extensive use of materials requiring larger amounts of material drawn from the Library's collections, more work space, greater physical security, and/or a more private environment than might be possible in a reading room. Study desk areas shall not be used as a primary office from which the project undertaken is operated, nor as a business location. Study desks are initially assigned for a period not to exceed one year, with the assignment and termination dates determined by the Head of the Main Reading Room Section, Humanities and Social Sciences Division. The assignment of a study desk beyond the first year may be made by the Chief of the Humanities and Social Sciences Division for a maximum of two years from the first assignment when there is a demonstrated need for the continuation of the assignment. Assignments beyond two years require an exception to this part and shall be specifically authorized by the Associate Librarian for Library Services. Any researcher who demonstrates a continuing need for a facility beyond an expiration date may reapply, but priority will be given to applicants on the waiting list who meet the specific criteria.

(c) *Congressional use of study rooms.* Rooms 225A-225E in the James Madison Building are available for the exclusive use of Members of Congress and Committees for official research that re-

quires use of the Library's collections or files in the Congressional Research Service. Assignment of study rooms shall be made in accordance with the Resolution of the Joint Committee on the Library of September 12, 1959, which states: " \* \* \* occupancy of study rooms assigned to Members should not be delegated to others than members of their own office staff who are paid no less than 20 hours per week from U.S. Government funds and at a rate of not less than the minimum salary of a GS-3 clerk-typist \* \* \*, and that Members should not request assignments of rooms for themselves merely for the purpose of sponsoring the work of private individuals and non-Government groups. \* \* \*" Rooms are assigned for one year or the life of the project, whichever is less, with the assignment and termination dates determined by the Director of the Congressional Relations Office.

[62 FR 64280, Dec. 5, 1997]

### § 701.9 Loans of library materials.

The Library of Congress is not a public circulating library and no material in its collections may be taken from the Library buildings except upon approval by the Chief of the Loan Division. Members of Congress, heads of executive departments, and other statutory borrowers, however, have the privilege of withdrawing books by virtue of their office. Subject to regulations and conditions established by The Librarian of Congress, special permission to withdraw materials may be given to congressional staff. Applications for such privilege are acted upon by the Chief of the Loan Division, who is responsible for the interpretation and enforcement of the regulations governing loans. Except for Members of Congress, heads of executive departments, and others authorized by the Librarian to have materials assembled and delivered to them, persons having the borrowing privilege must present materials to be borrowed to the Loan Division for recording and for issuance of a door pass. Borrowers must present the materials for inspection to the guards on duty at the exits to the Library buildings. Materials are issued on interlibrary loan to other libraries

within and outside the District of Columbia under regulations established by the Librarian of Congress. Applications from established libraries for such loans, and requests for information about interlibrary loans and loan service, generally, should be directed to the Chief of the Loan Division.

[35 FR 10588, June 30, 1970. Redesignated at 38 FR 27049, Sept. 28, 1973, and amended at 46 FR 48661, Oct. 2, 1981; 51 FR 22073, June 18, 1986]

**§ 701.10 Loans of library materials for blind and other physically handicapped persons.**

(a) *Program.* In connection with the Library's program of service under the Act of March 3, 1931 (46 Stat. 1487), as amended, its National Library Service for the Blind and Physically Handicapped provides books in raised characters (braille), on sound reproduction recordings, or in any other form, under regulations established by the Librarian of Congress. The National Library Service also provides and maintains reproducers for such sound reproduction recordings for the use of blind and other physically handicapped residents of the United States, including the several States, Territories, Insular Possessions, and the District of Columbia, and American citizens temporarily domiciled abroad.

(b) *Eligibility criteria.* (1) The following persons are eligible for such service:

(i) Blind persons whose visual acuity, as determined by competent authority, is 20/200 or less in the better eye with correcting glasses, or whose widest diameter if visual field subtends an angular distance no greater than 20 degrees.

(ii) Persons whose visual disability, with correction and regardless of optical measurement, is certified by competent authority as preventing the reading of standard printed material.

(iii) Persons certified by competent authority as unable to read or unable to use standard printed material as a result of physical limitations.

(iv) Persons certified by competent authority as having a reading disability resulting from organic dysfunction and of sufficient severity to prevent their reading printed material in a normal manner.

(2) In connection with eligibility for loan services "competent authority" is defined as follows:

(i) In cases of blindness, visual disability, or physical limitations "competent authority" is defined to include doctors of medicine, doctors of osteopathy, ophthalmologists, optometrists, registered nurses, therapists, professional staff of hospitals, institutions, and public or welfare agencies (e.g., social workers, case workers, counselors, rehabilitation teachers, and superintendents). In the absence of any of these, certification may be made by professional librarians or by any persons whose competence under specific circumstances is acceptable to the Library of Congress.

(ii) In the case of reading disability from organic dysfunction, competent authority is defined as doctors of medicine who may consult with colleagues in associated disciplines.

(c) *Loans through regional libraries.* Sound reproducers are lent to individuals and appropriate centers through agencies, libraries, and other organizations designated by the Librarian of Congress to service specific geographic areas, to certify eligibility of prospective readers, and to arrange for maintenance and repair of reproducers. Libraries designated by the Librarian of Congress serve as local or regional centers for the direct loan of such books, reproducers, or other specialized material to eligible readers in specific geographic areas. They share in the certification of prospective readers, and utilize all available channels of communication to acquaint the public within their jurisdiction with all aspects of the program.

(d) *National collections.* The Librarian of Congress, through the National Library Service for the Blind and Physically Handicapped, defines regions and determines the need for new regional libraries in cooperation with other libraries or agencies whose activities are primarily concerned with the blind and physically handicapped. It serves as the center from which books, recordings, sound reproducers, and other specialized materials are lent to eligible blind and physically handicapped readers who may be temporarily domiciled outside the jurisdictions enumerated

## Library of Congress

## § 701.13

by the Act. It maintains a special collection of books in raised characters and on sound reproduction recordings not housed in regional libraries and makes these materials available to eligible borrowers on interlibrary loan.

(e) *Institutions.* The reading materials and sound reproducers for the use of blind and physically handicapped persons may be loaned to individuals who qualify, to institutions such as nursing homes and hospitals, and to schools for the blind or physically handicapped for the use of such persons only. The reading materials and sound reproducers may also be used in public or private schools where handicapped students are enrolled; however, the students in public or private schools must be certified as eligible on an individual basis and must be the direct and only recipients of the materials and equipment.

(f) *Musical scores.* The National Library Service also maintains a library of musical scores, instructional texts, and other specialized materials for the use of the blind and other physically handicapped residents of the United States and its possessions in furthering their educational, vocational, and cultural opportunities in the field of music. Such scores, texts, and materials are made available on a loan basis under regulations developed by the Librarian of Congress in consultation with persons, organizations, and agencies engaged in work for the blind and for other physically handicapped persons.

(g) *Veterans.* In the lending of such books, recordings, reproducers, musical scores, instructional texts, and other specialized materials, preference shall be at all times given to the needs of the blind and other physically handicapped persons who have been honorably discharged from the Armed Forces of the United States.

(h) Inquiries for information relative to the prescribed procedures and regulations governing such loans and requests for loans should be addressed to: Director, National Library Service for the Blind and Physically Handicapped, Library of Congress, Washington, DC 20542.

[39 FR 20203, June 7, 1974, as amended at 46 FR 48661, Oct. 2, 1981]

### § 701.11 Lending of materials from the Library for exhibition.

Subject to special conditions and procedures determined by the Library, certain materials in the Library's collections are available for loan to recognized institutions, such as libraries and museums, with established exhibition programs and with staffs proficient in handling the particular material requested. This service is subject to limitations in terms of the character of the materials and the availability of staff to prepare materials for shipment. Each request for loan is judged on its particular merits, i.e., type of institution and program for which loan is proposed in relation to the importance and value, both monetary and intrinsic, of the material requested and the probability of its being replaceable in the event of loss. Communications concerning the lending of materials for exhibition should be addressed to the Exhibits Officer, Library of Congress, Washington, DC 20540.

[35 FR 10588, June 30, 1970. Redesignated at 38 FR 27049, Sept. 28, 1973]

### § 701.12 Photoduplication service.

Photocopies of materials in the Library's general and special collections may be obtained from the Library's Photoduplication Service at prevailing rates and subject to prescribed contract provisions, provided that they are not subject to copyright or other restrictions, or provided that permission to copy has been obtained. Order forms for photocopies may be secured from the Photoduplication Service, Library of Congress, Washington, DC 20540.

[35 FR 10588, June 30, 1970. Redesignated at 38 FR 27049, Sept. 28, 1973]

### § 701.13 Service of African and Middle Eastern materials.

(a) Services to readers in the African and Middle Eastern Division are provided in accordance with prescribed conditions of use of materials in the custody of the division: materials written or printed in Arabic, Hebrew, Persian, Turkish, Yiddish, etc.

(b) Readers requiring reference and bibliographic assistance in the general areas of African and Middle Eastern studies are assisted in the African and

#### § 701.14

Middle Eastern Division's three component sections: African, Hebraic, and Near East, each of which maintains a reference collection and pertinent bibliographic tools. Reference service on special materials of interest to African and Middle Eastern studies (except law) is provided by the divisions holding such materials, as identified in § 701.5. In the fields of science and technology, reference and bibliographic services are provided by the Science and Technology Division.

[51 FR 22073, June 18, 1986]

#### § 701.14 Service of Asian materials.

(a) Services to readers in the Asian Division are provided in accordance with prescribed conditions of use of materials in the custody of the division: materials written or printed in Bengali, Burmese, Chinese, Hindi, Indonesian, Japanese, Korean, Thai, Urdu, Vietnamese, etc.

(b) Readers requiring reference and bibliographic assistance in the general areas of Asian studies are assisted in the Asian Division's three component sections. Reference service on special materials of interest to Asian studies (except law) is provided by the divisions holding such materials, as identified in § 701.5. In the fields of science and technology, reference and bibliographic services are provided by the Science and Technology Division.

[51 FR 22073, June 18, 1986]

#### § 701.15 Service of European materials.

(a) Services to readers in the European Division are provided in accordance with prescribed conditions of use of the materials in the custody of the European Division: Unbound serials and newspapers, (with the exception of those assigned to the Law Library), written or printed in any of the Slavic languages and in Estonian, Latvian, and Lithuanian. Readers requesting reference and bibliographic assistance on European materials classified in the general collections are assisted by staff on duty in the general reading rooms, or in the European Reading Room, which maintains a reference collection and pertinent informational files.

(b) The professional staff of the European Division renders reference and

#### 36 CFR Ch. VII (7-1-03 Edition)

bibliographic services pertaining to the cultural, political, social, and economic life of Albania, Austria, Belgium, Bulgaria, Cyprus, Czechoslovakia, Denmark, Estonia, Finland, France, the German Democratic Republic, the Federal Republic of Germany, Greece, Hungary, Iceland, Italy, Latvia, Liechtenstein, Lithuania, Luxembourg, Monaco, The Netherlands, Norway, Poland, Romania, San Marino, the Soviet Union, Sweden, Switzerland, the Vatican City, and Yugoslavia. Reference service on special materials of interest to European studies (except law) is provided by the divisions holding such materials, as identified in § 701.5. In the fields of science and technology, reference and bibliographic services are provided by the Science and Technology Division.

[51 FR 22073, June 18, 1986]

#### § 701.16 Service of folklife materials.

(a) The American Folklife Center renders specialized reference, bibliographic and consulting services pertaining to "preserving and presenting" folk cultural traditions in the United States. The Center is not a grant-giving agency but concentrates on varied services to the field—coordination of folk cultural activities, local, state, Federal and at the Library of Congress; field projects, technical and consultant services; research and archival service; and publications, exhibits and live presentations designed to disseminate ideas and materials pertaining to American folk culture.

(b) The Center's Archive of Folk Song provides reference and referral services concerning folklife and ethnomusicology by telephone, through correspondence, and directly to readers in the Archive's Reading Room on the Library's pertinent collection of books, periodicals, recordings, manuscripts, etc. Printed descriptions of the Archive's published reference and findings aids, recordings, intern program, and other services, are available from the Archive of Folk Culture, Library of Congress, Washington, DC 20540.

[46 FR 48663, Oct. 2, 1981, as amended at 51 FR 22073, June 18, 1986]

## Library of Congress

## § 701.22

### § 701.17 Service of Hispanic materials.

(a) Readers requesting reference and bibliographic assistance on hispanic materials classified in the general collections may consult staff on duty in the general reading rooms, or in the Hispanic Reading Room, which maintains a reference collection and pertinent informational files.

(b) The professional staff of the Hispanic Division renders reference and bibliographic services pertaining to the cultural, political, social and economic life of Spain, Portugal, and the countries of Latin America and the Caribbean, as well as for materials pertaining to the social and cultural life of Hispanics in the United States. Reference service on special materials of interest to Hispanic studies (except law) is provided by the divisions holding such materials, as identified in § 701.5. In the fields of science and technology, reference and bibliographic services are provided by the Science and Technology Division.

[51 FR 22074, June 18, 1986]

### § 701.18 Service of legal materials.

(a) Legal materials are served in the reading room of the Law Library in the James Madison Building. Those volumes which are not on the open shelves may be obtained for reading room use by filling out and presenting to a reference assistant a slip provided for the purpose.

(b) The collections of the Law Library are available in part, for use outside the Library for a limited period, to authorized borrowers in Washington, DC, and through interlibrary loan to the general public residing in other parts of the country, in conformity with Loan Division procedures. Books which are lent for use outside of the Law Library must be charged in the Law Library. Books which are lent for use outside the Library building must be charged in the Loan Division, where a formal charge is made and a door pass is issued.

[46 FR 48662, Oct. 2, 1981]

### § 701.19 Service of local history and genealogical materials.

Readers requesting reference and bibliographic assistance on materials in

local history and genealogy may consult the staff in the Local History and Genealogy Room.

[46 FR 48662, Oct. 2, 1981]

### § 701.20 Service of manuscript materials.

(a) Services to readers in the Manuscript Reading Room are provided in accordance with prescribed conditions of reader registration and use of the materials in the custody of the Manuscript Division. The use of such materials is restricted to the Manuscript Reading Room.

(b) The professional staff of the Manuscript Division renders reference and bibliographic services pertaining to its collections by telephone, through correspondence, and directly to adult readers in the Manuscript Reading Room.

[51 FR 22074, June 18, 1986]

### § 701.21 Service of maps and cartographic materials.

(a) Services to readers in the Geography and Map Reading Room are provided in accordance with prescribed conditions of reader registration and use of the maps, atlases and globes in the custody of the Geography and Map Division. The use of such materials is restricted to the Geography and Map Reading Room.

(b) The professional staff of the Geography and Map Division renders reference and bibliographic services pertaining to its collections by telephone, through correspondence, and directly to adult readers in the Geography and Map Reading Room.

[51 FR 22074, June 18, 1986]

### § 701.22 Service of microfilmed materials.

(a) Service to readers in the Microform Reading Room is provided in accordance with conditions governing the use of microfilm and microprint material in the custody of the Microform Reading Room. Investigators may requisition inkprint materials from other collections of the Library for use in the Microform Reading Room, but such requests will be subject to limitations consistent with the care and service of the collections, and with

### § 701.23

regard for service to readers in other reading rooms.

(b) Other units have custody of microfilmed materials, such as manuscripts, newspapers, music, law, and orientalia, and render service on these materials.

[46 FR 48662, Oct. 2, 1981]

### § 701.23 Service of motion picture and television materials.

(a) Services to readers in the Motion Picture and Television Reading Room are provided in accordance with prescribed conditions of reader registration and use of the motion picture film, and videotape materials in the custody of the Motion Picture, Broadcasting and Recorded Sound Division. The use of such materials is restricted to the Motion Picture and Television Reading Room.

(b) The professional staff of the Motion Picture, Broadcasting and Recorded Sound Division renders reference and filmographic services pertaining to its collections by telephone, through correspondence and directly to adult readers in the Motion Picture and Television Reading Room.

[51 FR 22074, June 18, 1986]

### § 701.24 Service of music materials.

(a) Services to readers in the Performing Arts Reading Room are provided in accordance with prescribed conditions of reader registration and use of the music materials in the custody of the Music Division. The use of such materials is restricted to the Performing Arts Reading Room.

(b) The professional staff of the Music Division renders reference and bibliographic services pertaining to its collections, by telephone, through correspondence and directly to adult readers in Performing Arts Reading Room (see also § 701.29).

[51 FR 22074, June 18, 1986]

### § 701.25 Service of prints and photographs.

(a) Services to readers in the Prints and Photographs Reading Room are provided in accordance with prescribed conditions of reader registration and use of the collections of fine and historical prints, drawings, photographs,

### 36 CFR Ch. VII (7-1-03 Edition)

posters, and architectural drawings and photographs, in the custody of the Prints and Photographs Division. The use of such materials is restricted to the Prints and Photographs Reading Room.

(b) The professional staff of the Prints and Photographs Division renders reference and bibliographic services pertaining to its collections, by telephone, through correspondence and directly to adult readers in the Prints and Photographs Reading Room.

[51 FR 22074, June 18, 1986]

### § 701.26 Service of rare books and special collections.

(a) Services to readers in the Rare Book and Special Collections Reading Room are provided in accordance with prescribed conditions of reader registration and use of the materials in the custody of the Rare Book and Special Collections Division. The use of such materials is restricted to the Rare Book and Special Collections Reading Room.

(b) The professional staff of the Rare Book and Special Collections Division renders reference and bibliographic services pertaining to its collections by telephone, through correspondence, and directly to adult readers in the Rare Book and Special Collections Reading Room.

(c) Service to readers of the rare books in the custody of the Law Library and the Music Division are subject to similar regulations.

[51 FR 22074, June 18, 1986]

### § 701.27 Service of scientific and technical materials.

(a) Readers requesting reference and bibliographic assistance in science and technology may consult the staff on duty in the Science Reading Room. Inquiries are referred when necessary to subject specialists in the Science and Technology Division. A special collection of technical reports is available in the Science Reading Room. Materials on science in the Library's subject-classified collections are also served in the Library's other general reading rooms.

(b) In answering requests for referral service, the Resources Analysis Section

## Library of Congress

## § 701.31

of the General Reading Rooms Division compiles names, addresses, telephone numbers, and brief descriptions of appropriate informational resources, which may include professional societies, university research bureaus and institutes, Federal and State agencies, industrial laboratories, museums, testing stations, and individual experts as well as more traditional sources of information, such as technical libraries, information and document centers, and abstracting and indexing services.

[51 FR 22074, June 18, 1986]

### § 701.28 Service of serial materials.

(a) Services to readers in the Newspaper and Current Periodical Reading Room are provided in accordance with prescribed conditions of use of the collections of current and unbound periodicals, bound, unbound and micro-filmed newspapers, Government documents, ephemera, etc. not assigned to other divisions, in the custody of the Serial and Government Publications Division. The use of such materials is restricted to the Newspaper and Current Periodical Reading Room.

(b) The professional staff of the Serial and Government Publications Division renders reference and bibliographic services pertaining to its collections as well as to the government publications in the general classified collections, by telephone, through correspondence and directly to adult readers in the Newspaper and Current Periodical Reading Room.

[51 FR 22074, June 18, 1986]

### § 701.29 Service of sound recordings.

(a) Services to readers in the Recorded Sound Reference Center in the Performing Arts Reading Room are provided in accordance with prescribed conditions of reader registration and use of the sound recordings of all kinds (except recordings for the blind) in the custody of the Motion Picture, Broadcasting and Recorded Sound Division. The use of such materials, for serious research only, is restricted to the Performing Arts Reading Room and appointments to use them must be sought in advance by application to the Motion Picture, Broadcasting and Recorded Sound Division.

(b) The professional staff of the Recorded Sound Reference Center renders reference and discographic services pertaining to the collections, by telephone, through correspondence, and directly to adult readers in the Performing Arts Reading Room.

(c) Reference and information pertaining to folk music and ethnomusicology are available from the Archive of Folk Culture, American Folklife Center.

(d) A list of recordings of poetry and folk music issued by the Library of Congress and available for a sale may be obtained from the Public Services Coordinator, Motion Picture, Broadcasting and Recorded Sound Division, Library of Congress, Washington, DC 20540.

[51 FR 22075, June 18, 1986]

### § 701.30 Cataloging distribution.

Bibliographic products and services are produced and supplied to the Library of Congress and other libraries by the Cataloging Distribution Service. The Service sells bibliographic data in the form of printed cards, machine-readable tapes (MARC), book catalogs, microfiche catalogs and technical publications to libraries, learned societies, professional institutions, government agencies, private institutions, and cooperative and commercial processing centers. Information may be obtained from the Cataloging Distribution Service, Library of Congress.

[51 FR 22075, June 18, 1986]

### § 701.31 Library of Congress publications.

Publications of the Library include guides to its collections and services, catalogs of materials in the Library of Congress and other libraries, lists and descriptions of serials and monographs received, registers of personal papers of American public figures, bibliographies, facsimiles of rare items in its collections, exhibit catalogs, annual reports, acquisitions reports, and various other issuances relating to the Library and its programs. Most of the Library's publications are sold by the Superintendent of Documents, Government Printing Office, Washington, DC

## § 701.32

20402. A complete list of available publications, *Library of Congress Publications in Print*, is distributed free by the Central Services Division, Library of Congress, Washington, DC 20540.

[46 FR 48663, Oct. 2, 1981, as amended at 51 FR 22075, June 18, 1986]

### § 701.32 Offers of materials for purchase.

The Library solicits offers of library materials (including books, periodicals, pamphlets, manuscripts, maps, views, music, recordings, motion pictures, photographs, posters, prints, etc.). Lists or catalogs offering materials should specify author, title, place of publication, date of publication, whether or not copyrighted, edition note, series note, and number of pages or volumes. Each item must be priced. All offers of materials and all other correspondence concerning the acquisition by purchase of materials for the Library's collections (including invoices, statements, and questions concerning payment for material purchased by the Library) should be addressed to the Library of Congress, Order Division, Washington, DC 20504. Materials should be sent "on approval" unless specifically requested by the Order Division.

[51 FR 22075, June 18, 1986; 51 FR 23537, June 30, 1986]

### § 701.33 Acquisition of library materials by non-purchase means and disposition of surplus library materials.

(a) *Gifts.* It is the policy of the Library of Congress to foster the enrichment of its collections through gifts of materials within the terms of the Library's acquisitions policies. In implementing this policy, division chiefs and other authorized officers of the Library may undertake, as representatives of the Library, preliminary negotiations for gifts to the Library. However, responsibility for formal acceptance of gifts of material and for approval of conditions of such gifts rests with The Librarian of Congress or his designee. The Chief, African/Asian Acquisitions and Overseas Operations Division, Chief, Anglo-American Acquisitions Division, and Chief, European and Latin American Acquisitions Division

## 36 CFR Ch. VII (7-1-03 Edition)

are responsible for routine gifts in the geographic areas covered by their divisions.

(b) *Deposits.* (1) The Anglo-American Acquisitions Division is the only division in the Library authorized to make technical arrangements, formally negotiate for the transportation of materials and conditions of use at the Library, and prepare written Agreements of Deposit to formalize these negotiations. The term "deposit" is used to mean materials which are placed in the custody of the Library for general use on its premises, but which remain the property of their owners during the time of deposit and until such time as title in them may pass to the Library of Congress. A deposit becomes the permanent property of the Library when title to it is conveyed by gift or bequest. A deposit may be withdrawn by the owner rather than conveyed to the Library. A deposit shall be accompanied by a signed Agreement of Deposit.

(2) It is the policy of the Library of Congress to accept certain individual items or special collections as deposits when: permanent acquisition of such materials cannot be effected immediately; the depositors give reasonable assurance of their intention to donate the materials deposited to the United States of America for the benefit of the Library of Congress; the Library of Congress determines that such ultimate transfer of title will enrich its collections; and the depositors agree that the materials so deposited may be available for unrestricted use or use in the Library under reasonable restrictions.

(c) *Methods of disposition of surplus and/or duplicate materials—(1) Exchange.* All libraries may make selections on an exchange basis from the materials available in the "Exchange/Transfer" category. The policy governing these selections is that exchange be made only when materials of approximately equal value are expected to be furnished in return within a reasonable period. Dealers also may negotiate exchanges of this type for items selected from available exchange materials, but surplus copyright deposit copies of works published after 1977 shall not knowingly be exchanged with dealers.



**Library of Congress**

**§ 701.34**

Offers of exchange submitted by libraries shall be submitted to the Chief of the African/Asian Acquisitions and Overseas Operations Division, Anglo-American Acquisitions Division, or European/Latin American Acquisitions Division, or their designees, as appropriate, who shall establish the value of the material concerned. Offers from dealers shall be referred to the Chief of the Anglo-American Acquisitions Division. Exchange offers involving materials valued at \$1,000 or more must be approved by the Acquisitions Division Chief; offers of \$10,000 or more must be approved by the Director for Acquisitions and Support Services; and offers of \$50,000 or more must be approved by the Associate Librarian for Library Services. The Library also explicitly reserves the right to suspend, for any period of time it deems appropriate, the selection privileges of any book dealer who fails to comply fully with any rules prescribed for the disposal of library materials under this section or any other pertinent regulations or statutes.

(2) *Transfer of materials to Government Agencies.* Library materials no longer needed by the Library of Congress, including the exchange use mentioned above, shall be available for transfer to Federal agency libraries or to the District of Columbia Public Library, upon the request of appropriate officers of such entities, and may be selected from both the "Exchange/Transfer" and "Donation" categories. Existing arrangements for the transfer of materials, such as the automatic transfer of certain classes of books, etc., to specified Government libraries, shall be continued unless modified by the Library.

(3) *Donations of Library materials to educational institutions, public bodies, and nonprofit tax-exempt organizations in the United States.* It is the Library's policy, in keeping with the Federal Property and Administrative Services Act of 1949, 40 U.S.C. 471 *et seq.*, which does not cover the Library of Congress, to use materials no longer needed for any of the purposes mentioned above to strengthen the educational resources of the Nation by enriching the book collections of educational institutions (full-time, tax-supported or nonprofit schools, school systems, colleges, uni-

versities, museums, and public libraries), public bodies (agencies of local, state, or Federal Government), and nonprofit tax-exempt organizations (section 501 of the Internal Revenue Code of 1954, 26 U.S.C. 501, (see 41 CFR 101-44.207 (a)(17)) by authorizing the Anglo-American Acquisitions Division to donate to such groups in the United States any materials selected by their representatives. Eligibility to participate in the donation program shall be limited as defined by procedures established by the Anglo-American Acquisitions Division.

(4) *Disposition of residue.* Library materials not needed for the collections of the Library, for its exchange and transfer programs, for sale, or for donation, and which, in the opinion of the Chief, Anglo-American Acquisitions Division, have no commercial value, may be turned over to the General Services Administration (GSA) to be disposed of in accordance with standard Government practice.

[65 FR 11735, Mar. 6, 2000]

**§ 701.34 Contracting officers.**

Incumbents of the following positions are authorized to contract for materials and services on behalf of the Library of Congress and to execute contracts in the areas as specified below. The Librarian of Congress may further delegate contracting authority in specific situations.

Library officers	Area of contracting authority
The Librarian of Congress.	All areas.
The Deputy Librarian of Congress.	All areas.
The Associate Librarian of Congress.	All areas.
Associate Librarian for Management.	All areas except materials for the Library's collections.
Director, Congressional Research Service (CRS).	Agreements to procure experts or consultants (including stenographic reporters) pursuant to 2 U.S.C. 166(h)(2).
Assistant Librarian for Research Services.	Performance fees for readings, lectures, dramatic fees, and the Council of Scholars.
Director, Library Environment Resources Office.	Rental/space agreements with Government agencies.
Director, Acquisitions and Overseas Operations, Processing Services.	Agreements for bibliographic services.

§ 701.35

36 CFR Ch. VII (7-1-03 Edition)

Library officers	Area of contracting authority
Director, National Library for the Blind and Physically Handicapped.	Collection materials for the Library's blind and physically handicapped program.
Director of Publishing.	Agreements directly related to publications of the Publishing Office.
Chief, Procurement and Supply Division.	All areas except materials for the Library's collections.
Chief and Assistant Chief, Order Division.	Purchased materials for the Library's collections.
Chief and Assistant Chief, Exchange and Gift Division.	Agreements involving all non-purchase materials for the Library's collections (exchanges, gifts, deposits, and so forth).
Chief, Financial Management Office, and Budget Officer.	Interagency agreements, entertainment, performance of services by the Library and interdepartmental charges.
Chief, Manuscript Division.	Agreements involving the Library's literature programs (nonappropriated funds).
Chief, Music Division.	Agreements involving the Library's music programs (nonappropriated funds).
Exhibits Officer .....	Agreements involving loans of exhibits.
Staff Training and Development Officer.	Training agreements with educational institutions.

[52 FR 34383, Sept. 11, 1987]

**§ 701.35 Policy on the authorized use of the Library name, seal, or logo.**

(a) *Purpose.* The purpose of this part is three-fold:

(1) To assure that the Library of Congress is properly and appropriately identified and credited as a source of materials in publications.

(2) To assure that the name or logo of the Library of Congress, or any unit thereof, is used only with the prior approval of the Librarian of Congress or his designee; and

(3) To assure that the seal of the Library of Congress is used only on official documents or publications of the Library.

(b) *Definitions.* (1) For the purposes of this part, *publication* means any tangible expression of words or thoughts in any form or format, including print, sound recording, television, optical disc, software, online delivery, or other technology now known or hereinafter created. It includes the whole range of tangible products from simple signs, posters, pamphlets, and brochures to books, television productions, and movies.

(2) *Internal Library publication* means a publication over which any unit of the Library has complete or substantial control or responsibility.

(3) *Cooperative publications* are those in which the Library is a partner with the publisher by terms of a cooperative publishing agreement.

(4) *Commercial publications* are those known or likely to involve subsequent mass distribution, whether by a for-profit or not-for-profit organization or individual, which involve a cooperative agreement. A commercial publication can also include a significant number of LC references and is also approved by the LC office that entered into a formal agreement. Noncommercial publications are those which are produced by non-commercial entities.

(5) *Internet sites* are those on-line entities, both commercial and non-commercial, that have links to the Library's site.

(6) *Library logo* refers to any official symbol of the Library or any entity thereof and includes any design officially approved by the Librarian of Congress for use by Library officials.

(7) *Seal* refers to any statutorily recognized seal.

(c) *Credit and recognition policy.* (1) The name "Library of Congress," or any abbreviation or subset such as "Copyright Office" or "Congressional Research Service," thereof, is used officially to represent the Library of Congress and its programs, projects, functions, activities, or elements thereof. The use of the Library's name, explicitly or implicitly to endorse a product or service, or materials in any publication is prohibited, except as provided for in this part.

(2) The Library of Congress seal symbolizes the Library's authority and standing as an official agency of the U.S. Government. As such, it shall be displayed only on official documents or publications of the Library. The seal of the Library of Congress Trust Fund Board shall be affixed to documents of that body as prescribed by the Librarian of Congress. The seal of the National Film Preservation Board shall be affixed to documents of that body as prescribed by the Librarian of Congress. Procedures governing the use of

## Library of Congress

## § 701.35

any Library of Congress logo or symbol are set out below.

(3) Questions regarding the appropriateness of the use of any Library logos or symbols, or the use of the Library's name, shall be referred to the Public Affairs Officer.

(4) *Internal Publications.* Each internal Library publication shall include a copy of an official Library logo in a position, format, and location suitable to the particular media involved. The logo may be alone or in addition to an approved unit or activity logo, but shall be no less prominent than any other logo used, except in the cases of the Copyright Office, the Congressional Research Service, and the Center for the Book. Other exceptions to this policy may be made only if a written request is approved by the Executive Committee member under whose jurisdiction the publication falls.

(5) *Cooperative Ventures.* (i) Individual, commercial enterprises or non-commercial entities with whom the Library has a cooperative agreement to engage in cooperative efforts shall be instructed regarding Library policy on credit, recognition, and endorsement by the officer or manager with whom they are dealing.

(ii) Ordinarily, the Library logo should appear in an appropriate and suitable location on all cooperative publications. The Library requires that a credit line accompany reproductions of images from its collections and reflect the nature of the relationship such as "published in association with \* \* \*".

(iii) The size, location, and other attributes of the logo and credit line should be positioned in such a way that they do not imply Library endorsement of the publication unless such endorsement is expressly intended by the Library, as would be the case in cooperative activities. Use of the Library name or logo in any context suggesting an explicit or implicit endorsement may be approved in only those instances where the Library has sufficient control over the publication to make changes necessary to reflect Library expertise.

(iv) Library officers working on cooperative projects shall notify all collaborators of Library policy in writing

if the collaboration is arranged through an exchange of correspondence. All uses of the Library of Congress's name, seal or logo on promotional materials must be approved by the Public Affairs Officer, in consultation with the Office of the General Counsel, in advance. A statement of Library policy shall be incorporated into the agreement if the terms of the collaboration are embodied in any written instrument, such as a contract or letter of understanding. The statement could read as follows:

NAME OF PARTNER recognizes the great value, prestige and goodwill associated with the name, "Library of Congress" and any logo pertaining thereto. NAME OF PARTNER agrees not to knowingly harm, misuse, or bring into disrepute the name or logo of the Library of Congress, and further to assist the Library, as it may reasonably request, in preserving all rights, integrity and dignity associated with its name. Subject to the Library's prior written approval over all aspects of the use and presentation of the Library's name and logo, the NAME OF PARTNER may use the name of the Library of Congress in connection with publication, distribution, packaging, advertising, publicity and promotion of the \_\_\_\_, produced as a result of this Agreement. The Library will have fifteen (15) business days from receipt of NAME OF PARTNER'S written request to approve or deny with comment such requests for use of its name or logo.

(5) *Noncommercial Users.* Library officers assisting individuals who are non-commercial users of Library resources shall encourage them to extend the customary professional courtesy of acknowledging their sources in publications, including films, television, and radio, and to use approved credit lines.

(6) Each product acquired for resale by the Library that involves new labeling or packaging shall bear a Library logo and shall contain information describing the relevance of the item to the Library or its collections. Items not involving new packaging shall be accompanied by a printed description of the Library and its mission, with Library logo, as well as the rationale for operating a gift shop program in a statement such as, "Proceeds from gift shop sales are used to support the Library collections and to further the Library's educational mission."

(7) *Electronic Users.* Links to other sites from the Library of Congress's

§ 701.36

36 CFR Ch. VII (7-1-03 Edition)

site should adhere to the Appropriate Use Policy for External Linking in the Internet Policies and Procedures Handbook. Requests for such linkage must be submitted to the Public Affairs Office for review and approval.

(8) Office Systems Services shall make available copies of the Library seal or logo in a variety of sizes and formats, including digital versions, if use has been approved by the Public Affairs Officer, in consultation with the Office of General Counsel.

(9) Each service unit head shall be responsible for devising the most appropriate way to carry out and enforce this policy in consultation with the General Counsel and the Public Affairs Officer.

(e) *Prohibitions and Enforcement.* (1) All violations, or suspected violations, of this part, shall be reported to the Office of the General Counsel as soon as they become known. Whoever, except as permitted by laws of the U.S., or with the written permission of the Librarian of Congress or his designee, falsely advertises or otherwise represents by any device whatsoever that his or its business, product, or service has been in any way endorsed, authorized, or approved by the Library of Congress shall be subject to criminal penalties pursuant to law.

(2) Whenever the General Counsel has determined that any person or organization is engaged in or about to engage in an act or practice that constitutes or will constitute conduct prohibited by this part or a violation of any requirement of this part, the General Counsel shall take whatever steps are necessary, including seeking the assistance of the U.S. Department of Justice, to enforce the provisions of the applicable statutes and to seek all means of redress authorized by law, including both civil and criminal penalties.

[63 FR 8854, Feb. 23, 1998]

§ 701.36 Use of the Seal of the Library of Congress and the Library of Congress Trust Fund Board.

(a) The Seal is the official emblem of the Library of Congress and its use is therefore permitted only on official documents or publications of the Library.

(b) The Seal may be used on Library publications, leaflets, brochures, letterhead, or other printed matter prepared as official documents of the Library.

(c) The embossed Seal shall be used primarily to authenticate contracts, agreements, certifications, and other documents signed by The Librarian, or his/her designated representative(s).

(d) With the approval of The Associate Librarian of Congress, the Seal may be used in cooperative programs in which the Library officially engages with other organization(s).

(e) Any other use shall be approved in advance by The Associate Librarian of Congress.

(f) The official Seal of the Library of Congress Trust Fund Board shall be affixed to documents of that body as prescribed by The Librarian of Congress.

(g) Any person or organization that uses the Library Seal or the Seal of the Library of Congress Trust Fund Board in a manner other than as authorized by the provisions of this section shall be subject to the criminal provisions of 18 U.S.C. 1017.

[49 FR 8607, Mar. 8, 1984]

PART 702—CONDUCT ON LIBRARY PREMISES

- Sec.
702.1 Applicability.
702.2 Access to Library buildings and collections.
702.3 Conduct on Library premises.
702.4 Demonstrations.
702.5 Photographs.
702.6 Gambling.
702.7 Alcoholic beverages and controlled substances.
702.8 Weapons and explosives.
702.9 Use and carrying of food and beverages in Library buildings.
702.10 Inspection of property.
702.11 Protection of property.
702.12 Smoking In Library buildings.
702.13 Space for meetings and special events.
702.14 Soliciting, vending, debt collection, and distribution of handbills.
702.15 Penalties.

AUTHORITY: Sec. 1, 29 Stat. 544, 546; 2 U.S.C. 136.

§ 702.1 Applicability.

The rules and regulations in this part apply to all Federal property under the

## Library of Congress

## § 702.3

charge and control of the Librarian of Congress and to all persons entering in or on such property.

[35 FR 19019, Dec. 16, 1970. Redesignated at 38 FR 27049, Sept. 28, 1973]

### § 702.2 Access to Library buildings and collections.

Admittance and movement of visitors in Library buildings will be restricted to the areas providing facilities and services to the public during announced hours of public opening. Persons having legitimate business in areas closed to the public may be admitted after identification by responsible officials in the building or by authority as evidenced by a building access pass issued by the Associate Librarian for Management.

[35 FR 19019, Dec. 16, 1970. Redesignated at 38 FR 27049, Sept. 28, 1973, and amended at 46 FR 48663, Oct. 2, 1981]

### § 702.3 Conduct on Library premises.

(a) All persons using the premises shall conduct themselves in such manner as not to affect detrimentally the peace, tranquility, and good order of the Library. Such persons shall:

(1) Use areas that are open to them only at the times those areas are open to them and only for the purposes for which those areas are intended;

(2) Comply with any lawful order of the police or of other authorized individuals; and

(3) Comply with official signs of a restrictive or directory nature.

(b) All persons using the premises shall refrain from:

(1) Creating any hazard to persons or property, such as by fighting or by throwing or deliberately dropping any breakable article, such as glass, pottery, or any sharp article, or stones or other missiles;

(2) Using Library facilities for living accommodation purposes, such as unauthorized bathing, sleeping, or storage of personal belongings, regardless of the specific intent of the individual;

(3) Engaging in inordinately loud or noisy activities;

(4) Disposing of rubbish other than in receptacles provided for that purpose;

(5) Throwing articles of any kind from or at a Library building or appurtenance;

(6) Committing any obscene or indecent act such as prurient prying, indecent exposure, and soliciting for illegal purposes;

(7) Removing, defacing, damaging, or in any other way so misusing a statue, seat, wall, fountain, or other architectural feature or any tree, shrub, plant, or turf;

(8) Stepping upon or climbing upon any statue, fountain, or other ornamental architectural feature or any tree, shrub, or plant;

(9) Bathing or swimming in any fountain;

(10) Painting, marking or writing on, or posting or otherwise affixing any handbill or sign upon any part of a Library building or appurtenance, except on bulletin boards installed for that purpose and with the appropriate authorization;

(11) Bringing any animal onto Library buildings and turf other than dogs trained to assist hearing or visually impaired persons;

(12) Threatening the physical well-being of an individual; and

(13) Unreasonably obstructing reading rooms, food service facilities, entrances, foyers, lobbies, corridors, offices, elevators, stairways, or parking lots in such manner as to impede or disrupt the performance of official duties by the Library staff or to prevent Library patrons from using or viewing the collections.

(c) Public reading rooms, research facilities, and catalog rooms are designated as nonpublic forums. As such, they shall be used only for quiet scholarly research or educational purposes requiring use of Library materials. All persons using these areas shall comply with the rules in effect in the various public reading rooms, shall avoid disturbing other readers, and shall refrain from, but not limited to,

(1) Eating, drinking, or smoking in areas where these activities are expressly prohibited;

(2) Using loud language or making disruptive noises;

(3) Using any musical instrument or device, loudspeaker, sound amplifier, or other similar machine or device for the production or reproduction of

#### § 702.4

sound, except for devices to assist hearing or visually impaired persons, without authorization;

(4) Interfering by offensive personal hygiene with the use of the area by other persons;

(5) Spitting, defecating, urinating, or similar disruptive activities;

(6) Intentionally abusing the furniture or furnishings in the area;

(7) Intentionally damaging any item from the collections of the Library of Congress or any item of Library property;

(8) Using computing terminals for purposes other than searching or training persons to search the Library's data bases or those under contract to the Library, or misusing the terminals by intentional improper or obstructive searching; and

(9) Using the Library's photocopy machines for purposes other than copying Library materials whenever other persons are waiting in line.

[52 FR 672, Jan. 8, 1987]

#### § 702.4 Demonstrations.

(a) Library buildings and grounds are designated as limited public forums, except for those areas designated as nonpublic forums. However, only Library grounds (defined in 2 U.S.C. 167j), not buildings, may be utilized for demonstrations, including assembling, marching, picketing, or rallying. In addition, as the need for the determination of other matters arises, The Librarian will determine what additional First Amendment activities may not be permitted in a limited public forum. In making such determination, The Librarian will consider only whether the intended activity is incompatible with the primary purpose and intended use of that area.

(b) The only areas of the Library grounds that are designated for use for demonstrations are the following:

(1) *Thomas Jefferson Building*: The Neptune Plaza and the interior sidewalks on the north and south sides of the building;

(2) *John Adams Building*: The plaza in front of the south entrance to the building; and

(3) *James Madison Building*: The portion of Independence Plaza between the pylons that demarcate the driveway

#### 36 CFR Ch. VII (7-1-03 Edition)

and Independence Avenue, and the western and eastern ends of the plaza beyond the ramps for the handicapped.

(c) Persons seeking to use such designated areas for the purpose of demonstrations shall first secure written permission from the Associate Librarian for Management. An application for such permission shall be filed with the Library Support Services Office no later than three workdays before the time of the proposed demonstration. Permission to demonstrate shall be based upon—

(1) The availability of the requested location and

(2) The likelihood that the demonstration will not interfere with Library operations or exceed city noise limitations as defined by District of Columbia regulations (26 D.C. Reg. 229 and 24 D.C. Reg. 293).

(d) No person(s) having permission to demonstrate pursuant to this Regulation shall at any time block either the entrances to or exits from the Library buildings nor shall such person(s) harass, intimidate, or otherwise interfere with the use of the Library's facilities by persons not participating in the demonstration.

[52 FR 672, Jan. 8, 1987]

#### § 702.5 Photographs.

Photographs for advertising or commercial purposes may be taken only with the permission of the Library's Information Officer. Cameras and other photographic equipment may be carried on the premises, but their use in certain areas may be restricted by rules or posted signs. Persons using still, motion picture, or video cameras with flash attachments or lights or with tripods or other stationary equipment shall obtain the prior permission of the Library's Information Officer.

[52 FR 672, Jan. 8, 1987]

#### § 702.6 Gambling.

Participation in any illegal gambling, such as the operation of gambling devices, the conduct of an illegal pool or lottery, or the unauthorized sale or purchase of numbers or lottery tickets, on the premises is prohibited.

[52 FR 673, Jan. 8, 1987]

## Library of Congress

## § 702.13

### § 702.7 Alcoholic beverages and controlled substances.

(a) The use of alcoholic beverages on the premises is prohibited except on official occasions for which advance written approval has been given by the Associate Librarian for Management and except for concessionaires to whom Library management has granted permission to sell alcoholic beverages on the premises.

(b) The illegal use or possession of controlled substances on the premises is prohibited.

[52 FR 673, Jan. 8, 1987]

### § 702.8 Weapons and explosives.

Except where duly authorized by law, and in the performance of law enforcement functions, no person shall carry firearms, other dangerous or deadly weapons, or explosives, either openly or concealed, while on the premises.

[52 FR 673, Jan. 8, 1987]

### § 702.9 Use and carrying of food and beverages in Library buildings.

Consumption of food and beverages in Library buildings is prohibited except at point of purchase or other authorized eating places. Under no circumstances may food or beverages be carried to the bookstacks or other areas where there exists significant risk to Library materials or property or where there may result a detraction from the dignity or efficiency of public service.

[35 FR 19019, Dec. 16, 1970. Redesignated at 38 FR 27049, Sept. 28, 1973 and 52 FR 672, Jan. 8, 1987]

### § 702.10 Inspection of property.

(a) Individuals entering Library buildings do so with the understanding that all property in their possession including, but not limited to, suitcases, briefcases, large envelopes, packages, and office equipment may be inspected.

(b) Upon entering the Library buildings privately owned office machines including but not limited to typewriters, computing machines, stenotype machines, and dictating machines, shall be registered at the guard's desk at the entrance to buildings for the purpose of controlling such equipment.

(c) In the discharge of official duties, Library officials are authorized to inspect Government-owned or furnished property assigned to readers and the general public for their use, such as cabinets, lockers, and desks. Unauthorized property or contraband found in the possession of members of the Library staff, readers, or the general public as a result of such inspections will be subject to confiscation by Library officials.

[35 FR 19019, Dec. 16, 1970. Redesignated at 38 FR 27049, Sept. 28, 1973 and 52 FR 672, Jan. 8, 1987]

### § 702.11 Protection of property.

(a) Any person who shall steal, wrongfully deface, injure, mutilate, tear, or destroy library materials, or any portion thereof, shall be punished by a fine of not more than \$2,000 or imprisoned not more than 3 years, or both (18 U.S.C. 641; 18 U.S.C. 1361; 18 U.S.C. 2071; and 22 D.C. Code 3106).

(b) Any person who embezzles, steals, purloins, or, without authority, disposes of anything of value of the United States, or willfully injures or commits any depredation against any Government property shall be punished by a fine of not more than \$10,000 or imprisoned not more than 10 years, or both; but if the value of such property does not exceed the sum of \$100, he shall be fined not more than \$1,000 or imprisoned not more than 1 year, or both. (18 U.S.C. 641 and 18 U.S.C. 1361.)

[35 FR 19019, Dec. 16, 1970. Redesignated at 38 FR 27049, Sept. 28, 1973, and amended at 46 FR 48664, Oct. 2, 1981; further redesignated at 52 FR 672, Jan. 8, 1987]

### § 702.12 Smoking in Library buildings.

Smoking in Library buildings is prohibited except in those areas specifically designated for this purpose.

[35 FR 19019, Dec. 16, 1970. Redesignated at 38 FR 27049, Sept. 28, 1973 and 52 FR 672, Jan. 8, 1987]

### § 702.13 Space for meetings and special events.

The use of "meeting places" in the Library shall be limited to official staff functions, or functions sponsored by the Library. The Library's facilities

## § 702.14

are not available for meetings, performances or special events that: (a) Involve any organization practicing or promoting discrimination based upon race, religion, color, sex, age, marital status, handicap, national origin, or political affiliation; (b) have a partisan political, sectarian, or similar nature or purpose; (c) are sponsored by profit-making organizations that promote commercial enterprises or commodities.

[46 FR 48664, Oct. 2, 1981. Redesignated at 52 FR 672, Jan. 8, 1987]

### § 702.14 Soliciting, vending, debt collection, and distribution of handbills.

(a) The soliciting of alms and contributions, commercial soliciting and vending of all kinds, the display or distribution of commercial advertising, the offering or exposing of any article for sale, or the collecting of private debts on the grounds or within the buildings of the Library is prohibited. This rule does not apply to national or local drive for funds for welfare, health, or other purposes sponsored or approved by The Librarian of Congress, nor does it apply to authorized concessions, vending devices in approved areas, or as specifically allowed by the Associate Librarian for Management.

(b) Distribution of material such as pamphlets, handbills, and flyers is prohibited without prior approval of the Associate Librarian for Management.

(c) Peddlers and solicitors will not be permitted to enter Library buildings unless they have a specific appointment, and they will not be permitted to canvass Library buildings.

[52 FR 673, Jan. 8, 1987]

### § 702.15 Penalties.

(a) Persons violating provisions of 2 U.S.C. 167a to 167e, inclusive, regulations promulgated pursuant to 2 U.S.C. 167f, this Regulation, or other applicable Federal laws relating to the Library's property, including its collections, are subject to removal from the premises, to arrest, and to any additional penalties prescribed by law. In instances of mutilation or theft of Library materials or other Library property, prosecution by appropriate au-

## 36 CFR Ch. VII (7-1-03 Edition)

thorities shall be in accordance with the provisions of the statutes cited in § 702.11.

(b) Upon written notification by the Associate Librarian for Management, disruptive persons may be denied further access to the premises and may be prohibited from further use of the Library's facilities.

(1) Within three workdays of receipt of such notification, an affected individual may make a written request, including the reasons for such a request, to the Associate Librarian for Management for a reconsideration of said notification.

(2) The Associate Librarian for Management shall respond within three workdays of receipt of such request for reconsideration and may, at his or her option, rescind, modify, or reaffirm said notification.

[52 FR 673, Jan. 8, 1987]

## PART 703—DISCLOSURE OR PRODUCTION OF RECORDS OR INFORMATION

### Subpart A—Availability of Library of Congress Records

Sec.

703.1 Purpose and scope of this subpart.

703.2 Policy.

703.3 Administration responsibilities.

703.4 Definitions.

703.5 Records exempt from disclosure.

703.6 Procedures for access to and copying of records.

703.7 Public reading facility.

703.8 Fees and charges.

APPENDIX A TO SUBPART A—FEES AND CHARGES FOR SERVICES PROVIDED TO REQUESTORS OF RECORD

### Subpart B—testimony by Employees and Production of Documents in Certain Legal Proceedings Where the Library Is Not a Party

703.15 Purpose and scope of this subpart.

703.16 Policy on presentation of testimony and production of documents.

703.17 Procedures when testimony and/or documents are demanded.

703.18 Procedures when an employee's appearance is demanded or documents are demanded.

703.19 Requests for authenticated copies of Library documents.

703.20 File copies.

703.21 Effect of this part.



## Library of Congress

## § 703.4

703.22 Where to serve demands.

AUTHORITY: 2 U.S.C. 136.

SOURCE: 67 FR 16019, Apr. 4, 2002, unless otherwise noted.

### Subpart A—Availability of Library of Congress Records

#### § 703.1 Purpose and scope of this subpart.

(a) This subpart implements the policy of the Library with respect to the public availability of Library of Congress records. Although the Library is not subject to the Freedom of Information Act, as amended (5 U.S.C. 552), this subpart follows the spirit of that Act consistent with the Library's duties, functions, and responsibilities to the Congress. The application of that Act to the Library is not to be inferred, nor should this subpart be considered as conferring on any member of the public a right under that Act of access to or information from the records of the Library. Nothing in this subpart modifies current instructions and practices in the Library with respect to handling Congressional correspondence.

(b) The Copyright Office, although a service unit of the Library, is by law (17 U.S.C. 701) subject to the provisions of the Freedom of Information Act, as amended, only for purposes of actions taken under the copyright law. The Copyright Office has published its own regulation with respect to the general availability of information (*see* 37 CFR 201.2) and requests for copyright records made pursuant to the Freedom of Information Act (*see* 37 CFR 203.1 *et seq.*) and the Privacy Act (*see* 37 CFR 204.1 *et seq.*).

#### § 703.2 Policy.

(a) Subject to limitations set out in this part, Library of Congress records shall be available as hereinafter provided and shall be furnished as promptly as possible within the Library to any member of the public at appropriate places and times and for an appropriate fee, if any.

(b) The Library shall not provide records from its files that originate in another federal agency or non-federal organization to persons who may not be entitled to obtain the records from

the originator. In such instances, the Library shall refer requesters to the agency or organization that originated the records.

(c) In order to avoid disruption of work in progress, and in the interests of fairness to those who might be adversely affected by the release of information which has not been fully reviewed to assure its accuracy and completeness, it is the policy of the Library not to provide records which are part of on-going reviews or other current projects. In response to such requests, the Library will inform the requester of the estimated completion date of the review or project so that the requester may then ask for the records. At that time, the Library may release the records unless the same are exempt from disclosure as identified in § 703.5.

#### § 703.3 Administration responsibilities.

The administration of this part shall be the responsibility of the Chief, Office Systems Services (OSS), Library of Congress, 101 Independence Avenue, SE., Washington, DC 20540-9440, and to that end, the Chief may promulgate such supplemental rules or guidelines as may be necessary.

#### § 703.4 Definitions.

(a) *Records* includes all books, papers, maps, photographs, reports, and other documentary materials, exclusive of materials in the Library's collections, regardless of physical form or characteristics, made or received and under the control of the Library in pursuance of law or in connection with the transaction of public business, and retained, or appropriate for retention, by the Library as evidence of the organization, functions, policies, decisions, procedures, operations, or other activities of the government or because of the informational value of data contained therein. The term refers only to such items in being and under the control of the Library. It does not include the compiling or procuring of a record, nor does the term include objects or articles, such as furniture, paintings, sculpture, three-dimensional models, structures, vehicles, and equipment.

(b) *Identifiable* means a reasonably specific description of a particular

## § 703.5

record sought, such as the date of the record, subject matter, agency or person involved, etc. which will permit location or retrieval of the record.

(c) *Records available to the public* means records which may be examined or copied or of which copies may be obtained, in accordance with this part, by the public or representatives of the press regardless of interest and without specific justification.

(d) *Disclose* or *disclosure* means making available for examination or copying, or furnishing a copy.

(e) *Person* includes an individual, partnership, corporation, association, or public or private organization other than a federal agency.

### § 703.5 Records exempt from disclosure.

(a) The public disclosure of Library records provided for by this part does not apply to records, or any parts thereof, within any of the categories set out below. Unless precluded by law, the Chief, OSS, nevertheless may release records within these categories, except for Congressional correspondence and other materials identified in § 703.5(b)(1), after first consulting with the General Counsel.

(b) Records exempt from disclosure under this part are the following:

(1) Congressional correspondence and other materials relating to work performed in response to or in anticipation of Congressional requests, unless authorized for release by officials of the Congress.

(2) Materials specifically authorized under criteria established by Executive Order to be withheld from public disclosure in the interest of national defense or foreign policy and that are properly classified pursuant to Executive Orders.

(3) Records related solely to the internal personnel rules and practices of the Library. This category includes, in addition to internal matters of personnel administration, internal rules and practices which cannot be disclosed without prejudice to the effective performance of a Library function, such as guidelines and procedures used by auditors, investigators, or examiners in the Office of the Inspector General.

## 36 CFR Ch. VII (7-1-03 Edition)

(4) Records specifically exempted from disclosure by statute, provided that such statute:

(i) Requires that the matters be withheld from the public in such a manner as to leave no discretion on the issue, or

(ii) Establishes particular criteria for withholding or refers to particular types of matters to be withheld.

(5) Records containing trade secrets and commercial or financial information obtained from a person as privileged or confidential. This exemption may include, but is not limited to, business sales statistics, inventories, customer lists, scientific or manufacturing processes or development information.

(6) Personnel and medical files and similar files the disclosure of which could constitute a clearly unwarranted invasion of personal privacy. This exemption includes all private or personal information contained in files compiled to evaluate candidates for security clearances.

(7) Materials and information contained in investigative or other records compiled for law enforcement purposes.

(8) Materials and information contained in files prepared in connection with government litigation and adjudicative proceedings, except for those portions of such files which are available by law to persons in litigation with the Library.

(9) Records having information contained in or related to examination, operation, or condition reports prepared by, on behalf of, or for the use of an agency responsible for the regulation or supervision of financial institutions.

(10) Inter-agency or intra-agency memoranda, letters or other materials that are part of the deliberative process, the premature disclosure of which would inhibit internal communications or be detrimental to a Library function (e.g., case files in the Manuscript Division).

(11) Records containing information customarily subject to protection as privileged in a court or other proceedings such as information protected by the doctor-patient, attorney work product, or attorney-client privilege.

(12) Information submitted by a person to the Library in confidence or

which the Library has obligated itself not to disclose such as information received by the Office of the Inspector General through its hotline.

(13) Materials related to specific patron use of the Library's collections, resources, or facilities either on site or off site. This exemption includes:

(i) Reader Records. Library records which identify readers by name, such as registration records, reading room logs or registers, telephone inquiry logs, and charge slips, if retained for administrative purposes.

(ii) Use Records. Users of the Library are entitled to privacy with respect to their presence and use of the Library's facilities and resources. Records pertaining to the use of the Library and of Library collections and subjects of inquiry are confidential and are not to be disclosed either to other readers, to members of the staff who are not authorized, or to other inquirers including officials of law enforcement, intelligence, or investigative agencies, except pursuant to court order or administratively by order of the Librarian of Congress.

(c) Any reasonably segregable portion of a record shall be provided to anyone requesting such records after deletion of the portions which are exempt under this section. A portion of a record shall be considered reasonably segregable when segregation can produce an intelligible record which is not distorted out of context, does not contradict the record being withheld, and can reasonably provide all relevant information.

**§ 703.6 Procedure for access to and copying of records.**

(a) A request to inspect or obtain a copy of an identifiable record of the Library of Congress shall be submitted in writing to the Chief, OSS, Library of Congress, 101 Independence Avenue, SE., Washington, DC 20540-9440, who shall promptly record and process the request.

(b) Requests for records shall be specific and shall identify the precise records or materials that are desired by name, date, number, or other identifying data sufficient to allow the OSS staff to locate, retrieve, and prepare the record for inspection or copying

and to delete exempted matter where appropriate to do so. Blanket or generalized requests (such as "all matters relating to" a general subject) shall not be honored and shall be returned to the requester.

(c) Records shall be available for inspection and copying in person during business hours.

(d) Records in media other than print (*e.g.*, microforms and machine-readable media) shall be available for inspection in the medium in which they exist. Copies of records in machine-readable media shall be made in media determined by the Chief, OSS.

(e) Library staff shall respond to requests with reasonable dispatch. Use of a record by the Library or Library employees, however, shall take precedence over any request. Under no circumstances shall official records be removed from Library control without the written authorization of the Librarian.

(f) The Chief, OSS, shall make the initial determination on whether:

(1) The record described in a request can be identified and located pursuant to a reasonable search, and

(2) The record (or portions thereof) may be made available or withheld from disclosure under the provisions of this part. In making the initial determinations, the Chief shall consult with any unit in the Library having a continuing substantial interest in the record requested. Where the Chief finds no valid objection or doubt as to the propriety of making the requested record available, the Chief shall honor the request upon payment of prescribed fees, if any are required by § 703.8.

(g) If the Chief, OSS, determines that a requested record should be withheld, the Chief shall inform the requester in writing that the request has been denied; shall identify the material withheld; and shall explain the basis for the denial. The Chief shall inform the requester that further consideration of the denied request may be obtained by a letter to the General Counsel setting out the basis for the belief that the denial of the request was unwarranted.

(h) The General Counsel shall make the final determination on any request for reconsideration and shall notify the

## § 703.7

requester in writing of that determination. The decision of the General Counsel shall be the final administrative review within the Library.

(1) If the General Counsel's decision reverses in whole or in part the initial determination by the Chief, OSS, the Chief shall make the requested record, or parts thereof, available to the requester, subject to the provisions of § 703.8.

(2) If the General Counsel's decision sustains in whole or in part the initial determination by the Chief, OSS, the General Counsel shall explain the basis on which the record, or portions thereof, will not be made available.

### § 703.7 Public Reading Facility.

(a) The Chief, OSS, shall maintain a reading facility for the public inspection and copying of Library records. This facility shall be open to the public from 8:30 a.m. to 4:30 p.m., except Saturdays, Sundays, holidays, and such other times as the Library shall be closed to the public.

(b) The General Counsel shall advise the Chief, OSS, of the records to be available in the public reading facility following consultation with the Library managers who may be concerned.

### § 703.8 Fees and charges.

(a) The Library will charge no fees for:

(1) Access to or copies of records under the provisions of this part when the direct search and reproduction costs are less than \$10.

(2) Records requested which are not found or which are determined to be exempt under the provisions of this part.

(3) Staff time spent in resolving any legal or policy questions pertaining to a request.

(4) Copies of records, including those certified as true copies, that are furnished for official use to any officer or employee of the federal government.

(5) Copies of pertinent records furnished to a party having a direct and immediate interest in a matter pending before the Library, when furnishing such copies is necessary or desirable to the performance of a Library function.

(b) When the costs for services are \$10 or more, the Chief, OSS, shall assess

## 36 CFR Ch. VII (7-1-03 Edition)

and collect the fees and charges set out in appendix A to this part for the direct costs of search and reproduction of records available to the public.

(c) The Chief, OSS, is authorized to waive fees and charges, in whole or in part, where it is determined that the public interest is best served to do so, because waiver is likely to contribute significantly to public understanding of the operations or activities of the government and is not primarily in the commercial interest of the requester. Persons seeking a waiver or reduction of fees may be required to submit a written statement setting forth the intended purpose for which the records are requested or otherwise indicate how disclosure will primarily benefit the public and, in appropriate cases, explain why the volume of records requested is necessary. Determinations made pursuant to the authority set out herein are solely within the discretion of the Chief, OSS.

(d) Fees and charges for services identified in the appendix to this part shall be paid in full by the requester before the records are delivered. Payment shall be made in U.S. funds by personal check, money order, or bank draft made payable to the Library of Congress. The Chief, OSS, shall remit all fees collected to the Director, Financial Services, who shall cause the same to be credited to appropriate accounts or deposited with the U.S. Treasury as miscellaneous receipts.

(e) The Chief, OSS, shall notify a requester and may require an advance deposit where the anticipated fees will exceed \$50.

### APPENDIX A TO SUBPART A—FEES AND CHARGES FOR SERVICES PROVIDED TO REQUESTERS OF RECORDS

#### (a) Searches.

(1) There is no charge for searches of less than one hour.

(2) Fees charged for searches of one hour or more are based on prevailing rates. Currently, those charges are:

(i) Personnel searches (clerical): \$15 per hour.

(ii) Personnel searches (professional): \$25 per hour.

(iii) Reproduction costs: \$.50 per page.

(iv) Shipping and mailing fees: variable.

(3) In situations involving the use of computers to locate and extract the requested

information, charges will be based on the direct cost to the Library, including labor, material, and computer time.

(b) *Duplication of Records.* Fees charged for the duplication of records shall be according to the prevailing rates established by the Library's Photoduplication Service, or in the case of machine media duplication, by the Resources Management Staff, Information Technology Services.

(c) *Certifications.* The fee charges for certification of a record as authentic or a true copy shall be \$10.00 for each certificate.

(d) *Other Charges.* When no specific fee has been established for a service required to meet the request for records, the Chief, OSS, shall establish an appropriate fee based on direct costs in accordance with the Office of Management and Budget Circular No. A-25.

### **Subpart B—Testimony by Employees and Production of Documents in Certain Legal Proceedings Where the Library Is Not a Party**

#### **§ 703.15 Purpose and scope of this subpart.**

This subpart sets forth the policy and procedures of the Library of Congress regarding, first, the testimony, as witnesses in legal proceedings where the Library is not a party, of employees and former employees concerning information acquired in the course of performing official duties or because of the employee's official relationship with the Library of Congress, and second, the production or disclosure of information contained in Library of Congress documents for use in legal proceedings where the Library is not a party, pursuant to a request, order, or subpoena (collectively referred to in this subpart as a "demand").

(a) This subpart applies to:

- (1) State court proceedings (including grand jury proceedings);
- (2) Federal court proceedings; and
- (3) State and local legislative and administrative proceedings.

(b) This subpart does not apply to:

- (1) Matters that are not related to the Library of Congress but relate solely to an employee's personal dealings;
- (2) Congressional demands for testimony or documents;
- (3) Any demand relating to activity within the scope of Title 17 of the United States Code (the Copyright Act and related laws). These are governed

by Copyright Office regulations, which provide for different procedures and for service on the General Counsel of the Copyright Office. See 37 CFR 201.1, sec. 203, sec. 204, and sec. 205.

(c) The purpose of this subpart is to ensure that employees' official time is used only for official purposes, to maintain the impartiality of the Library of Congress among private litigants, to ensure that public funds are not used for private purposes, to ensure the protection of Congress' interests, and to establish centralized procedures for deciding whether or not to approve testimony or the production of documents.

#### **§ 703.16 Policy on presentation of testimony and production of documents.**

No Library of Congress employee may provide testimony or produce documents in any proceeding to which this part applies concerning information acquired in the course of performing official duties or because of the employee's official relationship with the Library of Congress, unless authorized by the General Counsel or his/her designee, or the Director of the Congressional Research Service (CRS) with respect to records and testimony relating to CRS's work for Congress, or the Law Librarian for records and testimony relating to the Law Library's work for Congress or materials prepared for other federal agencies covered by evidentiary privileges. The aforementioned officials (hereinafter "deciding officials") will consider and act upon demands under this part with due regard for the interests of Congress, where appropriate, statutory requirements, the Library's interests, and the public interest, taking into account factors such as applicable privileges and immunities, including the deliberative process privilege and the speech or debate clause, the need to conserve the time of employees for conducting official business, the need to avoid spending the time and money of the United States for private purposes, the need to maintain impartiality among private litigants in cases where a substantial government interest is not involved, the established legal standards for determining whether or not justification exists for the

### § 703.17

disclosure of confidential information and records, and any other purpose that the deciding official deems to be in the interest of Congress or the Library of Congress.

#### **§ 703.17 Procedures when testimony and/or documents are demanded.**

A demand for testimony and/or documents by a Library employee must be in writing, must state the nature of the requested testimony and/or specify documents, and must meet the requirements of § 703.15. A demand must also show that the desired testimony or document is not reasonably available from any other source and must show that no document could be provided and used in lieu of testimony. When an employee of the Library receives such a request the employee will immediately forward it, with the recommendation of the employee's supervisors, to the appropriate deciding official under § 703.22 of this part. The deciding official, in consultation with the appropriate offices of the Library or congressional offices, will determine whether or not compliance with the request would be appropriate and will respond as soon as practicable.

#### **§ 703.18 Procedures when an employee's appearance is demanded or documents are demanded.**

(a) If the deciding official has not acted by the return date on a subpoena, the employee must appear at the stated time and place (unless advised by the deciding official that the subpoena was not validly issued or served or that the subpoena has been withdrawn) and inform the court (or other interested parties) that the demand has been or is being, as the case may be, referred for the prompt consideration of the appropriate Library or congressional officials and shall respectfully request the court (or other authority) to stay the demand pending receipt of the requested instructions.

(b) If the deciding official has denied approval to comply with the subpoena, and the court or authority rules that the demand must be complied with irrespective of such a denial, the employee upon whom such a demand has been made shall produce a copy of this Part and shall respectfully refuse to

### 36 CFR Ch. VII (7-1-03 Edition)

provide any testimony or produce any documents. *United States ex rel. Touhy v. Ragen*, 340 U.S. 462 (1951).

(c) The deciding official, as appropriate, will request the assistance of the Department of Justice or the U.S. Attorney's Office or congressional officials where necessary to represent the interests of the Library, the Congress, and the employee in any of the foregoing proceedings.

#### **§ 703.19 Requests for authenticated copies of Library documents.**

Requests for authenticated copies of Library documents for purposes of admissibility under 28 U.S.C. 1733 and Rule 44 of the Federal Rules of Civil Procedure will be granted for documents that would otherwise be released pursuant to the Library's Regulations governing the release of information. The advice of the appropriate deciding official should be obtained concerning the proper form of authentication and information as to the proper person having custody of the record.

#### **§ 703.20 File copies.**

The Office of the General Counsel will maintain the official file of copies of all demands served on the Library and deciding officials' responses.

#### **§ 703.21 Effect of this part.**

This part is intended only to provide guidance for the internal operations of the Library of Congress and is not intended to, and does not, and may not, be relied upon to create any right or benefit, substantive or procedural, enforceable at law by a party against the Library of Congress or the United States.

#### **§ 703.22 Where to serve demands.**

Requesting parties must serve subpoenas:

(a) For Congressional Research Service matters: Director, Congressional Research Service, LM 203, Library of Congress, Washington, DC 20540.

(b) For Law Library matters: Law Librarian, LM 240, Library of Congress, Washington, DC 20540.

(c) For all other matters: General Counsel, LM 601, Library of Congress, Washington, DC 20540.

**PART 704—NATIONAL FILM REGISTRY OF THE LIBRARY OF CONGRESS**

**Subpart A—Films Selected for Inclusion in the National Film Registry**

Sec.

- 704.10 Criteria for the selection of films for inclusion in the National Film Registry.
- 704.11 Procedures for the public to recommend films for inclusion in the National Film Registry.
- 704.20 Films selected for inclusion in the National Film Registry in the Library of Congress for 1989.
- 704.21 Films selected for inclusion in the National Film Registry in the Library of Congress for 1990.
- 704.22 Films selected for inclusion in the National Film Registry in the Library of Congress for 1991.
- 704.23 Films selected for inclusion in the National Film Registry in the Library of Congress for 1992.
- 704.24 Films selected for inclusion in the National Film Registry in the Library of Congress for 1993.
- 704.25 Films Selected for Inclusion in the National Film Registry in the Library of Congress for 1994.
- 704.26 Films Selected for Inclusion in the National Film Registry in the Library of Congress for 1995.
- 704.27 Films Selected for Inclusion in the National Film Registry in the Library of Congress for 1996.
- 704.28 Films Selected for Inclusion in the National Film Registry in the Library of Congress for 1997.
- 704.29 Films Selected for Inclusion in the National Film Registry in the Library of Congress for 1998.
- 704.30 Films Selected for Inclusion in the National Film Registry in the Library of Congress for 1999.
- 704.31 Films Selected for Inclusion in the National Film Registry in the Library of Congress for 2000.
- 704.32 Films Selected for Inclusion in the National Film Registry in the Library of Congress for 2001.
- 704.33 Films Selected for Inclusion in the National Film Registry in the Library of Congress for 2002.

**Subpart B [Reserved]**

AUTHORITY: Public Law 102-307, 106 Stat. 267 (2 U.S.C. 179).

**Subpart A—Films Selected for Inclusion in the National Film Registry**

**§ 704.10 Criteria for the selection of films for inclusion in the National Film Registry.**

(a) All of the films nominated for inclusion in the National Film Registry should reflect the mission of the National Film Registry in the Library of Congress, found in section 202 of the National Film Preservation Act of 1992 (Pub. L. 102-307), of “maintaining and preserving films that are culturally, historically or aesthetically significant.”

(b) In accordance with the intent of Congress, all of the guidelines for the selection of films in the National Film Registry are intended to be read broadly, so that as many films as possible will be eligible for inclusion in the National Film Registry.

(c) For the purposes of film selection, the term “film” means a “motion picture” as defined in the U.S. copyright law, except, that the term “film” does not include any work not originally fixed on film stock, such as a work fixed on videotape or laser disks. “Motion pictures” are defined in the copyright law as: “audiovisual works consisting of a series of related images which, when shown in succession, impart an impression of motion, together with accompanying sounds, if any.” 17 U.S.C. 101.

(d) Films should not be considered for inclusion in the National Film Registry if no element or copy of the film exists. While the Librarian intends to promote the goals of film preservation and restoration provided for in the Act, no film will be denied inclusion in the National Film Registry because that film has already been preserved or restored.

(e) No film is eligible for inclusion in the National Film Registry until 10 years after such film’s first publication. “Publication” is defined in the copyright act as: “the distribution of copies or phonorecords of a work to the public by sale or other transfer of ownership, or by rental, lease, or lending. The offering to distribute copies or phonorecords to a group of persons for purposes of further distribution, public

## § 704.11

performance, or public display, constitutes publication. A public performance or display of a work does not of itself constitute publication.” 17 U.S.C. 101.

[58 FR 30708, May 27, 1993]

### § 704.11 Procedures for the public to recommend films for inclusion in the National Film Registry.

(a) The public shall be informed of all open meetings of the National Film Preservation Board.

(b) A mailing address within the Library of Congress will be maintained to allow the public to make nominations of films to the Librarian and the National Film Preservation Board. All nominations should include the film title, and any other relevant information necessary to prevent confusion with similarly named titles.

(c) Materials will be available to congressional offices and members of the Board to make information available to the public regarding nominations of films. Materials will also be made available for distribution to libraries, movie theaters, and through the guilds and societies representing directors, producers, screenwriters, actors, cinematographers, film critics, film preservation organizations and representatives of academic institutions with film study programs, in order to encourage broad participation from the general public. Nominations received by the Librarian, will be forwarded to the Board to assist in the film selection process.

(d) All nominations for inclusion of films in the National Film Registry must be submitted in writing to the Librarian of Congress no later than March 30th of each year. All nominations should be mailed to: National Film Registry, Library of Congress, Washington, DC 20540.

[58 FR 30709, May 27, 1993]

### § 704.20 Films selected for inclusion in the National Film Registry in the Library of Congress for 1989.

(a) The Librarian of Congress, Dr. James H. Billington, after consultation with the National Film Preservation Board registers these films in the National Film registry within the Library of Congress for 1989:

## 36 CFR Ch. VII (7-1-03 Edition)

- (1) The Best Years Of Our Lives (1946)
- (2) Casablanca (1942)
- (3) Citizen Kane (1941)
- (4) The Crowd (1928)
- (5) Dr. Strangelove (or, How I Learned To Stop Worrying And Love the Bomb) (1964)
- (6) The General (1927)
- (7) Gone With The Wind (1939)
- (8) The Grapes Of Wrath (1940)
- (9) High Noon (1952)
- (10) Intolerance (1916)
- (11) The Learning Tree (1969)
- (12) The Maltese Falcon (1941)
- (13) Mr. Smith Goes to Washington (1939)
- (14) Modern Times (1936)
- (15) Nanook Of The North (1922)
- (16) On The Waterfront (1954)
- (17) The Searchers (1956)
- (18) Singin' In The Rain (1952)
- (19) Snow White And The Seven Dwarfs (1937)
- (20) Some Like it Hot (1959)
- (21) Star Wars (1977)
- (22) Sunrise (1927)
- (23) Sunset Boulevard (1950)
- (24) Vertigo (1958)
- (25) The Wizard Of Oz (1939)

(b) In keeping with section 3(c) of the Act, 2 U.S.C. 178b, the Librarian will endeavor to obtain an archival quality copy for each of these twenty-five films for the National Film Board Collection in the Library of Congress.

[55 FR 32570, Aug. 9, 1990]

### § 704.21 Films selected for inclusion in the National Film Registry in the Library of Congress for 1990.

(a) The Librarian of Congress, Dr. James H. Billington, after consultation with the National Film Preservation Board registers these films in the National Film Registry within the Library of Congress for 1990:

- (1) All About Eve (1950)
- (2) All Quiet On the Western Front (1930)
- (3) Bringing Up Baby (1938)
- (4) Dodsworth (1936)
- (5) Duck Soup (1933)
- (6) Fantasia (1940)
- (7) The Freshman (1925)
- (8) The Godfather (1972)
- (9) The Great Train Robbery (1903)
- (10) Harlan County, U.S.A. (1976)
- (11) How Green Was My Valley (1941)
- (12) It's A Wonderful Life (1946)
- (13) Killer Of Sheep (1977)
- (14) Love Me Tonight (1932)
- (15) Meshes Of the Afternoon (1943)
- (16) Ninotchka (1939)
- (17) Primary (1960)
- (18) Raging Bull (1980)
- (19) Rebel Without A Cause (1955)



## Library of Congress

## § 704.24

- (20) Red River (1948)
- (21) The River (1937)
- (22) Sullivan's Travels (1941)
- (23) Top Hat (1935)
- (24) The Treasure Of The Sierra Madre (1948)
- (25) A Woman Under The Influence (1974)

(b) In keeping with section 3(c) of the Act (2 U.S.C. 178b), the Librarian will endeavor to obtain an archival quality copy for each of these twenty-five films for the National Film Board Collection in the Library of Congress.

[55 FR 52845, Dec. 24, 1990]

### § 704.22 Films Selected for Inclusion in the National Film Registry in the Library of Congress for 1991.

(a) The Librarian of Congress, Dr. James H. Billington, after consultation with the National Film Preservation Board registers these films in the National Film Registry within the Library of Congress for 1991:

- (1) 2001: A Space Odyssey (1968)
- (2) Battle Of San Pietro, The (1945)
- (3) Blood Of Jesus, The (1941)
- (4) Chinatown (1974)
- (5) City Lights (1931)
- (6) David Holzman's Diary (1968)
- (7) Frankenstein (1931)
- (8) Gertie The Dinosaur (1914)
- (9) Gigi (1958)
- (10) Greed (1924)
- (11) High School (1968)
- (12) I Am A Fugitive From A Chain Gang (1932)
- (13) Italian, The (1915)
- (14) King Kong (1933)
- (15) Lawrence Of Arabia (1962)
- (16) Magnificent Ambersons, The (1942)
- (17) My Darling Clementine (1946)
- (18) Out Of The Past (1947)
- (19) Place In The Sun, A (1951)
- (20) Poor Little Rich Girl (1917)
- (21) Prisoner of Zenda, The (1937)
- (22) Shadow Of A Doubt (1943)
- (23) Sherlock, Jr. (1924)
- (24) Tevye (1939)
- (25) Trouble In Paradise (1932)

(b) In keeping with section 3(c) of the Act, 2 U.S.C. 178b, the Librarian will endeavor to obtain an archival quality copy for each of these twenty-five films for the National Film Board Collection in the Library of Congress.

[56 FR 49414, Sept. 30, 1991]

### § 704.23 Films Selected for Inclusion in the National Film Registry in the Library of Congress for 1992.

(a) The Librarian of Congress, Dr. James H. Billington, after consultation with the National Film Preservation Board, registers these films in the National Film Registry within the Library of Congress for 1992:

1. Adam's Rib (1949)
2. Annie Hall (1977)
3. The Bank Dick (1940)
4. Big Business (1929)
5. The Big Parade (1925)
6. The Birth of a Nation (1915)
7. Bonnie and Clyde (1967)
8. Carmen Jones (1954)
9. Castro Street (1966)
10. Detour (1946)
11. Dog Star Man (1964)
12. Double Indemnity (1944)
13. Footlight Parade (1933)
14. The Gold Rush (1925)
15. Letter From an Unknown Woman (1948)
16. Morocco (1930)
17. Nashville (1975)
18. The Night of the Hunter (1955)
19. Paths of Glory (1957)
20. Psycho (1960)
21. Ride the High Country (1962)
22. Salesman (1969)
23. Salt of the Earth (1954)
24. What's Opera, Doc? (1957)
25. Within Our Gates (1920)

(b) In keeping with section 206(a) of the Act, 2 U.S.C. 179d(a), the Librarian shall endeavor to obtain an archival quality copy for each of these twenty-five films for the National Film Registry Collection of the Library of Congress.

[59 FR 35034, July 8, 1994]

### § 704.24 Films Selected for Inclusion in the National Film Registry in the Library of Congress for 1993.

(a) The Librarian of Congress, Dr. James H. Billington, after consultation with the National Film Preservation Board, registers these films in the National Film Registry within the Library of Congress for 1993:

1. An American in Paris (1951)
2. Badlands (1973)
3. The Black Pirate (1926)
4. Blade Runner (1982)
5. Cat People (1942)
6. The Cheat (1915)
7. Chulas Fronteras (1976)
8. Eaux D'Artifice (1953)
9. The Godfather, Part II (1974)

## § 704.25

10. His Girl Friday (1940)
11. It Happened One Night (1934)
12. Lassie Come Home (1943)
13. Magical Maestro (1952)
14. March of Time: Inside Nazi Germany—1938 (1938)
15. A Night at the Opera (1935)
16. Nothing But a Man (1964)
17. One Flew Over the Cuckoo's Nest (1975)
18. Point of Order (1964)
19. Shadows (1959)
20. Shane (1953)
21. Sweet Smell of Success (1957)
22. Touch of Evil (1958)
23. Where Are My Children? (1916)
24. The Wind (1928)
25. Yankee Doodle Dandy (1942)

(b) In keeping with section 206(a) of the Act, 2 U.S.C. 179d(a), the Librarian shall endeavor to obtain an archival quality copy for each of these twenty-five films for the National Film Registry Collection of the Library of Congress.

[59 FR 35035, July 8, 1994]

## § 704.25 Films Selected for Inclusion in the National Film Registry in the Library of Congress for 1994.

(a) The Librarian of Congress, Dr. James H. Billington, after consultation with the National Film Preservation Board, registers these films in the National Film Registry within the Library of Congress for 1994:

- (1) The African Queen (1951)
- (2) The Apartment (1960)
- (3) The Cool World (1963)
- (4) A Corner in Wheat (1909)
- (5) E.T. The Extra-Terrestrial (1982)
- (6) The Exploits of Elaine (1914)
- (7) Force of Evil (1948)
- (8) Freaks (1932)
- (9) Hell's Hinges (1916)
- (10) Hospital (1970)
- (11) Invasion of the Body Snatchers (1956)
- (12) The Lady Eve (1941)
- (13) Louisiana Story (1948)
- (14) The Manchurian Candidate (1962)
- (15) Marty (1955)
- (16) Meet Me in St. Louis (1944)
- (17) Midnight Cowboy (1969)
- (18) A Movie (1958)
- (19) Pinocchio (1940)
- (20) Safety Last (1923)
- (21) Scarface (1932)
- (22) Snow White (1933)
- (23) Tabu (1931)
- (24) Taxi Driver (1976)
- (25) Zapruder Film (1963)

(b) In keeping with section 106(a) of the Act, 2 U.S.C. 179(p), the Librarian

## 36 CFR Ch. VII (7-1-03 Edition)

shall endeavor to obtain an archival quality copy for each of these twenty-five films for the National Film Registry Collection of the Library of Congress.

[68 FR 11975, Mar. 13, 2003]

## § 704.26 Films Selected for Inclusion in the National Film Registry in the Library of Congress for 1995.

(a) The Librarian of Congress, Dr. James H. Billington, after consultation with the National Film Preservation Board, registers these films in the National Film Registry within the Library of Congress for 1995:

- (1) The Adventures of Robin Hood (1938)
- (2) All That Heaven Allows (1955)
- (3) American Graffiti (1973)
- (4) The Band Wagon (1953)
- (5) Blacksmith Scene (1893)
- (6) Cabaret (1972)
- (7) Chan Is Missing (1982)
- (8) The Conversation (1974)
- (9) The Day the Earth Stood Still (1951)
- (10) El Norte (1983)
- (11) Fatty's Tintype Tangle (1915)
- (12) The Four Horsemen of the Apocalypse (1921)
- (13) Fury (1936)
- (14) Gerald McBoing Boing (1951)
- (15) The Hospital (1971)
- (16) Jammin' the Blues (1944)
- (17) The Last of the Mohicans (1920)
- (18) Manhatta (1921)
- (19) North By Northwest (1959)
- (20) The Philadelphia Story (1940)
- (21) Rip Van Winkle (1896)
- (22) Seventh Heaven (1927)
- (23) Stagecoach (1939)
- (24) To Fly (1976)
- (25) To Kill a Mockingbird (1962)

(b) In keeping with section 106(a) of the Act, 2 U.S.C. 179(p), the Librarian shall endeavor to obtain an archival quality copy for each of these twenty-five films for the National Film Registry Collection of the Library of Congress.

[68 FR 11975, Mar. 13, 2003]

## § 704.27 Films Selected for Inclusion in the National Film Registry in the Library of Congress for 1996.

(a) The Librarian of Congress, Dr. James H. Billington, after consultation with the National Film Preservation Board, registers these films in the National Film Registry within the Library of Congress for 1996:

## Library of Congress

## § 704.29

- (1) The Awful Truth (1937)
- (2) Broken Blossoms (1919)
- (3) The Deer Hunter (1978)
- (4) Destry Rides Again (1939)
- (5) Flash Gordon serial (1936)
- (6) The Forgotten Frontier (1931)
- (7) Frank Film (1973)
- (8) The Graduate (1967)
- (9) The Heiress (1949)
- (10) The Jazz Singer (1927)
- (11) Life and Times of Rosie the Riveter (1980)
- (12) M\*A\*S\*H (1970)
- (13) Mildred Pierce (1945)
- (14) The Outlaw Josey Wales (1976)
- (15) The Producers (1968)
- (16) Pull My Daisy (1959)
- (17) Road to Morocco (1942)
- (18) She Done Him Wrong (1933)
- (19) Shock Corridor (1963)
- (20) Show Boat (1936)
- (21) The Thief of Baghdad (1924)
- (22) To Be Or Not To Be (1942)
- (23) Topaz (1943–45) (home movie footage taken at Japanese American Internment Camp, the Topaz War Relocation Authority Center)
- (24) Verbena Tragica (1939)
- (25) Woodstock (1970)

(b) In keeping with section 106(a) of the Act, 2 U.S.C. 179(p), the Librarian shall endeavor to obtain an archival quality copy for each of these twenty-five films for the National Film Registry Collection of the Library of Congress.

[68 FR 11975, Mar. 13, 2003]

### § 704.28 Films Selected for Inclusion in the National Film Registry in the Library of Congress for 1997.

(a) The Librarian of Congress, Dr. James H. Billington, after consultation with the National Film Preservation Board, registers these films in the National Film Registry within the Library of Congress for 1997:

- (1) Ben-Hur (1926)
- (2) The Big Sleep (1946)
- (3) The Bridge on the River Kwai (1957)
- (4) Cops (1922)
- (5) Czechoslovakia 1968 (1968)
- (6) Grass (1925)
- (7) The Great Dictator (1940)
- (8) Harold and Maude (1972)
- (9) Hindenburg Disaster Newsreel Footage (1937)
- (10) How the West Was Won (1962)
- (11) The Hustler (1961)
- (12) Knute Rockne, All American (1940)
- (13) The Life and Death of 9413—A Hollywood Extra (1928)
- (14) The Little Fugitive (1953)

- (15) Mean Streets (1973)
- (16) Motion Painting No. 1 (1947)
- (17) The Music Box (1932)
- (18) The Naked Spur (1953)
- (19) Rear Window (1954)
- (20) Republic Steel Strike Riots Newsreel Footage (1937)
- (21) Return of the Secaucus 7 (1980)
- (22) The Thin Man (1934)
- (23) Tulips Shall Grow (1942)
- (24) West Side Story (1961)
- (25) Wings (1927)

(b) In keeping with section 106(a) of the Act, 2 U.S.C. 179(p), the Librarian shall endeavor to obtain an archival quality copy for each of these twenty-five films for the National Film Registry Collection of the Library of Congress.

[68 FR 11975, Mar. 13, 2003]

### § 704.29 Films Selected for Inclusion in the National Film Registry in the Library of Congress for 1998.

(a) The Librarian of Congress, Dr. James H. Billington, after consultation with the National Film Preservation Board, registers these films in the National Film Registry within the Library of Congress for 1998:

- (1) Bride of Frankenstein (1935)
- (2) The City (1939)
- (3) Dead Birds (1964)
- (4) Don't Look Back (1967)
- (5) Easy Rider (1969)
- (6) 42nd Street (1933)
- (7) From the Manger to the Cross (1912)
- (8) Gun Crazy (1949)
- (9) The Hitch-Hiker (1953)
- (10) The Immigrant (1917)
- (11) The Last Picture Show (1972)
- (12) Little Miss Marker (1934)
- (13) The Lost World (1925)
- (14) Modesta (1956)
- (15) The Ox-Bow Incident (1943)
- (16) Pass the Gravy (1928)
- (17) Phantom of the Opera (1925)
- (18) Powers of Ten (1978)
- (19) The Public Enemy (1931)
- (20) Sky High (1922)
- (21) Steamboat Willie (1928)
- (22) Tacoma Narrows Bridge Collapse (1940)
- (23) Tootsie (1982)
- (24) Twelve O'Clock High (1949)
- (25) "Westinghouse Works, 1904" (1904)

(b) In keeping with section 106(a) of the Act, 2 U.S.C. 179(p), the Librarian shall endeavor to obtain an archival quality copy for each of these twenty-

### § 704.30

five films for the National Film Registry Collection of the Library of Congress.

[68 FR 11976, Mar. 13, 2003]

#### § 704.30 Films Selected for Inclusion in the National Film Registry in the Library of Congress for 1999.

(a) The Librarian of Congress, Dr. James H. Billington, after consultation with the National Film Preservation Board, registers these films in the National Film Registry within the Library of Congress for 1999:

- (1) Civilization (1916)
- (2) Do the Right Thing (1989)
- (3) The Docks of New York (1928)
- (4) Duck Amuck (1953)
- (5) The Emperor Jones (1933)
- (6) Gunga Din (1939)
- (7) In the Land of the Head-Hunters (1914) aka In the Land of the War Canoes
- (8) Jazz on a Summer's Day (1959)
- (9) King: A Filmed Record . . . Montgomery to Memphis (1970)
- (10) The Kiss (1896)
- (11) Kiss Me Deadly (1955)
- (12) Lambchops (1929)
- (13) Laura (1944)
- (14) Master Hands (1936)
- (15) My Man Godfrey (1936)
- (16) Night of the Living Dead (1968)
- (17) The Plow That Broke the Plains (1936)
- (18) Raiders of the Lost Ark (1981)
- (19) Roman Holiday (1953)
- (20) The Shop Around the Corner (1940)
- (21) A Streetcar Named Desire (1951)
- (22) The Ten Commandments (1956)
- (23) Trance and Dance in Bali (1938-39)
- (24) The Wild Bunch (1969)
- (25) Woman of the Year (1942)

(b) In keeping with section 106(a) of the Act, 2 U.S.C. 179(p), the Librarian shall endeavor to obtain an archival quality copy for each of these twenty-five films for the National Film Registry Collection of the Library of Congress.

[68 FR 11976, Mar. 13, 2003]

#### § 704.31 Films Selected for Inclusion in the National Film Registry in the Library of Congress for 2000.

(a) The Librarian of Congress, Dr. James H. Billington, after consultation with the National Film Preservation Board, registers these films in the National Film Registry within the Library of Congress for 2000:

- (1) Apocalypse Now (1979)

### 36 CFR Ch. VII (7-1-03 Edition)

- (2) Dracula (1931)
- (3) The Fall of the House of Usher (1928)
- (4) Five Easy Pieces (1970)
- (5) GoodFellas (1990)
- (6) Koyaanisqatsi (1983)
- (7) The Land Beyond the Sunset (1912)
- (8) Let's All Go to the Lobby (1957)
- (9) The Life of Emile Zola (1937)
- (10) Little Caesar (1930)
- (11) The Living Desert (1953)
- (12) Love Finds Andy Hardy (1938)
- (13) Multiple Sclerosis (1970)
- (14) Network (1976)
- (15) Peter Pan (1924)
- (16) Porky in Wackyland (1938)
- (17) President McKinley Inauguration Footage (1901)
- (18) Regeneration (1915)
- (19) Salome (1922)
- (20) Shaft (1971)
- (21) Sherman's March (1986)
- (22) A Star is Born (1954)
- (23) The Tall T (1957)
- (24) Why We Fight (series) (1943-45)
- (25) Will Success Spoil Rock Hunter? (1957)

(b) In keeping with section 106(a) of the Act, 2 U.S.C. 179(p), the Librarian shall endeavor to obtain an archival quality copy for each of these twenty-five films for the National Film Registry Collection of the Library of Congress.

[68 FR 11976, Mar. 13, 2003]

#### § 704.32 Films Selected for Inclusion in the National Film Registry in the Library of Congress for 2001.

(a) The Librarian of Congress, Dr. James H. Billington, after consultation with the National Film Preservation Board, registers these films in the National Film Registry within the Library of Congress for 2001:

- (1) Abbott and Costello Meet Frankenstein (1948)
- (2) All That Jazz (1979)
- (3) All the King's Men (1949)
- (4) America, America (1963)
- (5) Cologne: From the Diary of Ray and Esther (1939)
- (6) Evidence of the Film (1913)
- (7) Hoosiers (1986)
- (8) The House in the Middle (1954)
- (9) It (1927)
- (10) Jam Session (1942)
- (11) Jaws (1975)
- (12) Manhattan (1979)
- (13) Marian Anderson: The Lincoln Memorial Concert (1939)
- (14) Memphis Belle (1944)
- (15) The Miracle of Morgan's Creek (1944)
- (16) Miss Lulu Bett (1921)

## Library of Congress

## § 705.1

- (17) National Lampoon's Animal House (1978)
- (18) Planet of the Apes (1968)
- (19) Rose Hobart (1936)
- (20) Serene Velocity (1970)
- (21) The Sound of Music (1965)
- (22) Stormy Weather (1943)
- (23) The Tell-Tale Heart (1953)
- (24) The Thin Blue Line (1988)
- (25) The Thing From Another World (1951)

(b) In keeping with section 106(a) of the Act, 2 U.S.C. 179(p), the Librarian shall endeavor to obtain an archival quality copy for each of these twenty-five films for the National Film Registry Collection of the Library of Congress.

[68 FR 11976, Mar. 13, 2003]

### § 704.33 Films Selected for Inclusion in the National Film Registry in the Library of Congress for 2002.

(a) The Librarian of Congress, Dr. James H. Billington, after consultation with the National Film Preservation Board, registers these films in the National Film Registry within the Library of Congress for 2002:

- (1) Alien (1979)
- (2) All My Babies (1953)
- (3) The Bad and the Beautiful (1952)
- (4) Beauty and the Beast (1991)
- (5) The Black Stallion (1979)
- (6) Boyz N the Hood (1991)
- (7) Theodore Case Sound Test: Gus Visser and his Singing Duck (1925)
- (8) The Endless Summer (1966)
- (9) From Here to Eternity (1953)
- (10) From Stump to Ship (1930)
- (11) Fuji (1974)
- (12) In the Heat of the Night (1967)
- (13) Lady Windermere's Fan (1925)
- (14) Melody Ranch (1940)
- (15) The Pearl (1948)
- (16) Punch Drunks (1934)
- (17) Sabrina (1954)
- (18) Star Theatre (1901)
- (19) Stranger Than Paradise (1984)
- (20) This is Cinerama (1952)
- (21) This is Spinal Tap (1984)
- (22) Through Navajo Eyes (series) (1966)
- (23) Why Man Creates (1968)
- (24) Wild and Woolly (1917)
- (25) Wild River (1960)

(b) In keeping with section 106(a) of the Act, 2 U.S.C. 179(p), the Librarian shall endeavor to obtain an archival quality copy for each of these twenty-five films for the National Film Reg-

istry Collection of the Library of Congress.

[68 FR 11976, Mar. 13, 2003]

## Subpart B [Reserved]

## PART 705—FINANCIAL ADMINISTRATION

AUTHORITY: 5 U.S.C. 5514 and 5 CFR 550.1101.

### § 705.1 Salary offset

(a) *Purpose.* This part describes the rights of current and former staff members in the collection of debts owed to the Federal Government by them and sets out the procedures for collecting debts through deductions from their pay following due process.

(b) *Definitions.*—(1) *Debt* is an amount owed to the U.S. Government from insured or guaranteed loans, fees, leases, rents, royalties, services, sales of real or personal property, overpayments, penalties, damages, interest, fines and forfeitures (except those arising under the Uniform Code of Military Justice), and all other similar sources.

(2) *Disposable pay*, for purposes of this part, means that part of current basic pay, special pay, incentive pay, retirement pay, retainer pay, or other authorized pay remaining after the deduction of any amount required by law to be withheld, such as Federal taxes, retirement, court-ordered payments, and FICA.

(3) *Staff member* refers to current and former employees who owe debts to the Library and/or other Federal Government agencies.

(c) *Procedures*—(1) *Notification of indebtedness.* The Director of Human Resources, or designee, shall notify the staff member, in writing, of the individual's indebtedness to the Library and the intention of the Library to collect this debt by deductions from the individual's pay. This notice shall be given not less than 30 days before any deduction is made. This notice shall state, at a minimum:

(i) The Library's determination that a debt is owed, including the origin, nature, and amount of the debt;

(ii) The Library's intention to collect the debt by means of deduction from

§ 705.1

36 CFR Ch. VII (7-1-03 Edition)

the staff member's disposable pay account;

(iii) The amount, frequency, proposed beginning date, and duration of the intended deductions;

(iv) An explanation of the Library's policy concerning interest, penalties, and administrative costs, including a statement that such assessments must be made unless excused;

(v) The staff member's right to inspect and to copy Government records relating to the debt or, if he or she or his or her representative cannot personally inspect the records, to request and receive a copy of such records;

(vi) If not previously provided, the opportunity (under terms agreeable to the Library) to establish a schedule for the voluntary repayment of the debt or to enter into a written agreement to establish a schedule for the repayment of the debt in lieu of offset (the agreement must be in writing, signed by both the staff member and the Library, and documented in the Library's files);

(vii) The staff member's right to a hearing conducted by an official arranged for or engaged by the Library (an administrative law judge or, alternatively, a hearing official not under the control of the Librarian of Congress) if a petition is filed as prescribed by the Library;

(viii) The method and time period for petitioning for a hearing;

(ix) That the timely filing of a petition for hearing will stay the commencement of collection proceedings;

(x) That a final decision on the hearing, if one is requested, will be issued at the earliest practicable date, but not later than 60 days after the filing of the petition requesting the hearing unless the staff member requests and the hearing official grants a delay in the proceedings;

(xi) That any knowingly false or frivolous statements, representations, or evidence may subject the staff member to

(A) Disciplinary procedures appropriate under Library of Congress Regulation 2020-3, or any other applicable regulations or statutes,

(B) Penalties under the False Claim Act, Section 3729 of Title 31, U.S. Code, or any other applicable statutory authority, or

(C) Criminal penalties under Sections 286, 287, 1001, and 1002 of Title 18, U.S. Code, or any other applicable statutory authority;

(xii) Any other rights and remedies available to the staff member under statutes or regulations governing the program for which the collection is being made;

(xiii) Unless there are applicable contractual or statutory provisions to the contrary, that amounts paid on or deducted for the debt which are later waived or found not owed to the United States will be promptly refunded to the staff member;

(xiv) That if the staff member elects not to contest the determination of indebtedness or the amount or the terms of a repayment schedule, the staff member may still wish to exercise the right to request a waiver of the collection of the indebtedness pursuant to the provisions of Library of Congress Regulation 1556, *Claims* (if the amount of the indebtedness exceeds \$1,500, the staff member should be advised that a final determination must be made by the Comptroller General of the United States); and

(xv) That any involuntary payments already made or withheld from salary of any portion of the indebtedness will not be construed as a waiver by the staff member of any rights that he or she may have under this part.

(2) *Amount of deduction.* If possible, the debt shall be collected in one lump sum. If multiple deductions are necessary, however, the amount deducted from a staff member's pay for any single period will not exceed 15 percent of disposable pay, except that a greater percentage may be deducted upon the written consent of the individual involved. The staff member may enter into a written agreement for a repayment schedule different from that proposed so long as the terms are approved by the Library. If the individual retires or resigns or if his or her employment otherwise ends before collection of the amount of the indebtedness is completed, deduction shall be made from subsequent payments of any nature due the individual.

(3) *Petitions for hearing.* (i) To elect a hearing, the staff member must notify the Director, Human Resources, no

later than 15 days after the receipt of the notification of indebtedness. A timely filing of a petition for hearing will stay any further commencement of collection proceedings. A final decision on the hearing will be issued at the earliest practicable date, but not later than 60 days after the filing of petition, unless the individual requests and the hearing official grants a delay in the proceedings.

(ii) The petition or statement must be signed by the staff member and must fully identify and explain with reasonable specificity all the facts, evidence, and witnesses, if any, which he or she believes supports his or her position.

(iii) Petitions for hearings made later than 15 days after the receipt of the notification of indebtedness will be accepted provided the staff member can show that the delay was because of circumstances beyond his or her control or because of failure to receive notice of the time limit (unless otherwise aware of it).

(4) *Form of hearings and final decisions.* (i) The staff member shall be provided an appropriate hearing as decided by the hearing official, based on the nature of the transactions giving rise to the debt. The hearing official shall be guided by the procedures set out in 4 CFR 102.3(c) in deciding on the type of hearing to provide.

(ii) A written decision will be provided to the staff member and must, at a minimum, state the fact(s) purported to support the nature and origin of the alleged debt; the hearing official's analysis, findings, and conclusions, in light of the hearing, as to the staff member's or the Library's grounds; the amount and validity of the alleged debt; and, where applicable, the repayment schedule.

(d) *Creditor agency is not the Library of Congress.* When the Library receives from a creditor agency a debt claim properly certified in accordance with 5 CFR 550.1108(a), deductions shall be scheduled to begin at the next officially established pay interval. The Director, Human Resources, shall provide the employee with written notice stating that the Library has received a certified debt claim from the creditor agency (including the amount) and written notice of the date deductions from salary will commence and of the amount of such deductions. When the Library receives an incomplete debt claim from a creditor agency, the Director, Human Resources, shall return the debt claim with a written notice that procedures under 5 U.S.C. 5514 must be followed and a properly determined debt claim received before action will be taken to collect from the employee's pay account.

(e) *Exclusions and exceptions.* (1) This part does not apply to debts where collection of the debt is explicitly provided for or prohibited by another statute, or to debts of \$1 or less, which, it is hereby determined, is not cost effective to attempt to collect (65 Comp. Gen. 843, September 29, 1986).

(2) An exception to the entitlement of notice, hearings, written responses, and final decisions provided for under paragraph (c) of this section is made for overpayments arising out of an employee's election of coverage or a change in coverage under a Federal benefits program requiring periodic deductions from pay, if the amount to be recovered was accumulated over four pay periods or less.

[59 FR 38367, July 28, 1994]

**PARTS 706-799 [RESERVED]**





## CHAPTER VIII—ADVISORY COUNCIL ON HISTORIC PRESERVATION

---

<i>Part</i>		<i>Page</i>
800	Protection of historic properties. ....	101
801	Historic preservation requirements of the Urban Development Action Grant Program .....	125
805	Procedures for implementation of National Envi- ronmental Policy Act .....	138
810	Freedom of Information Act regulations .....	139
811	Employee responsibilities and conduct .....	142
812	Enforcement of nondiscrimination on the basis of handicap in programs or activities conducted by the Advisory Council on Historic Preservation ...	142
813-899	[Reserved]	



## PART 800—PROTECTION OF HISTORIC PROPERTIES

### Subpart A—Purposes and Participants

Sec.

800.1 Purposes.

800.2 Participants in the Section 106 process.

### Subpart B—The Section 106 Process

800.3 Initiation of the section 106 process.

800.4 Identification of historic properties.

800.5 Assessment of adverse effects.

800.6 Resolution of adverse effects.

800.7 Failure to resolve adverse effects.

800.8 Coordination with the National Environmental Policy Act.

800.9 Council review of Section 106 compliance.

800.10 Special requirements for protecting National Historic Landmarks.

800.11 Documentation standards.

800.12 Emergency situations.

800.13 Post-review discoveries.

### Subpart C—Program Alternatives

800.14 Federal agency program alternatives.

800.15 Tribal, State, and local program alternatives. [Reserved]

800.16 Definitions.

APPENDIX A TO PART 800—CRITERIA FOR COUNCIL INVOLVEMENT IN REVIEWING INDIVIDUAL SECTION 106 CASES

AUTHORITY: 16 U.S.C. 470s.

SOURCE: 65 FR 77725, Dec. 12, 2000, unless otherwise noted.

### Subpart A—Purposes and Participants

#### § 800.1 Purposes.

(a) *Purposes of the section 106 process.* Section 106 of the National Historic Preservation Act requires Federal agencies to take into account the effects of their undertakings on historic properties and afford the Council a reasonable opportunity to comment on such undertakings. The procedures in this part define how Federal agencies meet these statutory responsibilities. The section 106 process seeks to accommodate historic preservation concerns with the needs of Federal undertakings through consultation among the agency official and other parties with an interest in the effects of the undertaking on historic properties, commencing at the early stages of project planning.

The goal of consultation is to identify historic properties potentially affected by the undertaking, assess its effects and seek ways to avoid, minimize or mitigate any adverse effects on historic properties.

(b) *Relation to other provisions of the act.* Section 106 is related to other provisions of the act designed to further the national policy of historic preservation. References to those provisions are included in this part to identify circumstances where they may affect actions taken to meet section 106 requirements. Such provisions may have their own implementing regulations or guidelines and are not intended to be implemented by the procedures in this part except insofar as they relate to the section 106 process. Guidelines, policies, and procedures issued by other agencies, including the Secretary, have been cited in this part for ease of access and are not incorporated by reference.

(c) *Timing.* The agency official must complete the section 106 process “prior to the approval of the expenditure of any Federal funds on the undertaking or prior to the issuance of any license.” This does not prohibit agency official from conducting or authorizing non-destructive project planning activities before completing compliance with section 106, provided that such actions do not restrict the subsequent consideration of alternatives to avoid, minimize or mitigate the undertaking’s adverse effects on historic properties. The agency official shall ensure that the section 106 process is initiated early in the undertaking’s planning, so that a broad range of alternatives may be considered during the planning process for the undertaking.

#### § 800.2 Participants in the Section 106 process.

(a) *Agency official.* It is the statutory obligation of the Federal agency to fulfill the requirements of section 106 and to ensure that an agency official with jurisdiction over an undertaking takes legal and financial responsibility for section 106 compliance in accordance with subpart B of this part. The agency official has approval authority for the undertaking and can commit the Federal agency to take appropriate action

for a specific undertaking as a result of section 106 compliance. For the purposes of subpart C of this part, the agency official has the authority to commit the Federal agency to any obligation it may assume in the implementation of a program alternative. The agency official may be a State, local, or tribal government official who has been delegated legal responsibility for compliance with section 106 in accordance with Federal law.

(1) *Professional standards.* Section 112(a)(1)(A) of the act requires each Federal agency responsible for the protection of historic resources, including archeological resources, to ensure that all actions taken by employees or contractors of the agency shall meet professional standards under regulations developed by the Secretary.

(2) *Lead Federal agency.* If more than one Federal agency is involved in an undertaking, some or all the agencies may designate a lead Federal agency, which shall identify the appropriate official to serve as the agency official who shall act on their behalf, fulfilling their collective responsibilities under section 106. Those Federal agencies that do not designate a lead Federal agency remain individually responsible for their compliance with this part.

(3) *Use of contractors.* Consistent with applicable conflict of interest laws, the agency official may use the services of applicants, consultants, or designees to prepare information, analyses and recommendations under this part. The agency official remains legally responsible for all required findings and determinations. If a document or study is prepared by a non-Federal party, the agency official is responsible for ensuring that its content meets applicable standards and guidelines.

(4) *Consultation.* The agency official shall involve the consulting parties described in paragraph (c) of this section in findings and determinations made during the section 106 process. The agency official should plan consultations appropriate to the scale of the undertaking and the scope of Federal involvement and coordinated with other requirements of other statutes, as applicable, such as the National Environmental Policy Act, the Native American Graves Protection and Repa-

triation Act, the American Indian Religious Freedom Act, the Archeological Resources Protection Act, and agency-specific legislation. The Council encourages the agency official to use to the extent possible existing agency procedures and mechanisms to fulfill the consultation requirements of this part.

(b) *Council.* The Council issues regulations to implement section 106, provides guidance and advice on the application of the procedures in this part, and generally oversees the operation of the section 106 process. The Council also consults with and comments to agency officials on individual undertakings and programs that affect historic properties.

(1) *Council entry into the section 106 process.* When the Council determines that its involvement is necessary to ensure that the purposes of section 106 and the act are met, the Council may enter the section 106 process. Criteria guiding Council decisions to enter the section 106 process are found in appendix A to this part. The Council will document that the criteria have been met and notify the parties to the section 106 process as required by this part.

(2) *Council assistance.* Participants in the section 106 process may seek advice, guidance and assistance from the Council on the application of this part to specific undertakings, including the resolution of disagreements, whether or not the Council is formally involved in the review of the undertaking. If questions arise regarding the conduct of the section 106 process, participants are encouraged to obtain the Council's advice on completing the process.

(c) *Consulting parties.* The following parties have consultative roles in the section 106 process.

(1) *State historic preservation officer.* (i) The State historic preservation officer (SHPO) reflects the interests of the State and its citizens in the preservation of their cultural heritage. In accordance with section 101(b)(3) of the act, the SHPO advises and assists Federal agencies in carrying out their section 106 responsibilities and cooperates with such agencies, local governments and organizations and individuals to

ensure that historic properties are taken into consideration at all levels of planning and development.

(ii) If an Indian tribe has assumed the functions of the SHPO in the section 106 process for undertakings on tribal lands, the SHPO shall participate as a consulting party if the undertaking takes place on tribal lands but affects historic properties off tribal lands, if requested in accordance with § 800.3(c)(1), or if the Indian tribe agrees to include the SHPO pursuant to § 800.3(f)(3).

(2) *Indian tribes and Native Hawaiian organizations.* (i) *Consultation on tribal lands.* (A) *Tribal historic preservation officer.* For a tribe that has assumed the responsibilities of the SHPO for section 106 on tribal lands under section 101(d)(2) of the act, the tribal historic preservation officer (THPO) appointed or designated in accordance with the act is the official representative for the purposes of section 106. The agency official shall consult with the THPO in lieu of the SHPO regarding undertakings occurring on or affecting historic properties on tribal lands.

(B) *Tribes that have not assumed SHPO functions.* When an Indian tribe has not assumed the responsibilities of the SHPO for section 106 on tribal lands under section 101(d)(2) of the act, the agency official shall consult with a representative designated by such Indian tribe in addition to the SHPO regarding undertakings occurring on or affecting historic properties on its tribal lands. Such Indian tribes have the same rights of consultation and concurrence that the THPOs are given throughout subpart B of this part, except that such consultations shall be in addition to and on the same basis as consultation with the SHPO.

(ii) *Consultation on historic properties of significance to Indian tribes and Native Hawaiian organizations.* Section 101(d)(6)(B) of the act requires the agency official to consult with any Indian tribe or Native Hawaiian organization that attaches religious and cultural significance to historic properties that may be affected by an undertaking. This requirement applies regardless of the location of the historic property. Such Indian tribe or Native

Hawaiian organization shall be a consulting party.

(A) The agency official shall ensure that consultation in the section 106 process provides the Indian tribe or Native Hawaiian organization a reasonable opportunity to identify its concerns about historic properties, advise on the identification and evaluation of historic properties, including those of traditional religious and cultural importance, articulate its views on the undertaking's effects on such properties, and participate in the resolution of adverse effects. It is the responsibility of the agency official to make a reasonable and good faith effort to identify Indian tribes and Native Hawaiian organizations that shall be consulted in the section 106 process. Consultation should commence early in the planning process, in order to identify and discuss relevant preservation issues and resolve concerns about the confidentiality of information on historic properties.

(B) The Federal Government has a unique legal relationship with Indian tribes set forth in the Constitution of the United States, treaties, statutes, and court decisions. Consultation with Indian tribes should be conducted in a sensitive manner respectful of tribal sovereignty. Nothing in this part alters, amends, repeals, interprets, or modifies tribal sovereignty, any treaty rights, or other rights of an Indian tribe, or preempts, modifies, or limits the exercise of any such rights.

(C) Consultation with an Indian tribe must recognize the government-to-government relationship between the Federal Government and Indian tribes. The agency official shall consult with representatives designated or identified by the tribal government or the governing body of a Native Hawaiian organization. Consultation with Indian tribes and Native Hawaiian organizations should be conducted in a manner sensitive to the concerns and needs of the Indian tribe or Native Hawaiian organization.

(D) When Indian tribes and Native Hawaiian organizations attach religious and cultural significance to historic properties off tribal lands, section 101(d)(6)(B) of the act requires Federal agencies to consult with such Indian

## § 800.2

## 36 CFR Ch. VIII (7–1–03 Edition)

tribes and Native Hawaiian organizations in the section 106 process. Federal agencies should be aware that frequently historic properties of religious and cultural significance are located on ancestral, aboriginal, or ceded lands of Indian tribes and Native Hawaiian organizations and should consider that when complying with the procedures in this part.

(E) An Indian tribe or a Native Hawaiian organization may enter into an agreement with an agency official that specifies how they will carry out responsibilities under this part, including concerns over the confidentiality of information. An agreement may cover all aspects of tribal participation in the section 106 process, provided that no modification may be made in the roles of other parties to the section 106 process without their consent. An agreement may grant the Indian tribe or Native Hawaiian organization additional rights to participate or concur in agency decisions in the section 106 process beyond those specified in subpart B of this part. The agency official shall provide a copy of any such agreement to the Council and the appropriate SHPOs.

(F) An Indian tribe that has not assumed the responsibilities of the SHPO for section 106 on tribal lands under section 101(d)(2) of the act may notify the agency official in writing that it is waiving its rights under § 800.6(c)(1) to execute a memorandum of agreement.

(3) *Representatives of local governments.* A representative of a local government with jurisdiction over the area in which the effects of an undertaking may occur is entitled to participate as a consulting party. Under other provisions of Federal law, the local government may be authorized to act as the agency official for purposes of section 106.

(4) *Applicants for Federal assistance, permits, licenses, and other approvals.* An applicant for Federal assistance or for a Federal permit, license, or other approval is entitled to participate as a consulting party as defined in this part. The agency official may authorize an applicant or group of applicants to initiate consultation with the SHPO/THPO and others, but remains legally responsible for all findings and deter-

minations charged to the agency official. The agency official shall notify the SHPO/THPO when an applicant or group of applicants is so authorized. A Federal agency may authorize all applicants in a specific program pursuant to this section by providing notice to all SHPO/THPOs. Federal agencies that provide authorizations to applicants remain responsible for their government-to-government relationships with Indian tribes.

(5) *Additional consulting parties.* Certain individuals and organizations with a demonstrated interest in the undertaking may participate as consulting parties due to the nature of their legal or economic relation to the undertaking or affected properties, or their concern with the undertaking's effects on historic properties.

(d) *The public.* (1) *Nature of involvement.* The views of the public are essential to informed Federal decision-making in the section 106 process. The agency official shall seek and consider the views of the public in a manner that reflects the nature and complexity of the undertaking and its effects on historic properties, the likely interest of the public in the effects on historic properties, confidentiality concerns of private individuals and businesses, and the relationship of the Federal involvement to the undertaking.

(2) *Providing notice and information.* The agency official must, except where appropriate to protect confidentiality concerns of affected parties, provide the public with information about an undertaking and its effects on historic properties and seek public comment and input. Members of the public may also provide views on their own initiative for the agency official to consider in decisionmaking.

(3) *Use of agency procedures.* The agency official may use the agency's procedures for public involvement under the National Environmental Policy Act or other program requirements in lieu of public involvement requirements in subpart B of this part, if they provide adequate opportunities for public involvement consistent with this subpart.

### Subpart B—The section 106 Process

#### § 800.3 Initiation of the section 106 process.

(a) *Establish undertaking.* The agency official shall determine whether the proposed Federal action is an undertaking as defined in § 800.16(y) and, if so, whether it is a type of activity that has the potential to cause effects on historic properties.

(1) *No potential to cause effects.* If the undertaking is a type of activity that does not have the potential to cause effects on historic properties, assuming such historic properties were present, the agency official has no further obligations under section 106 or this part.

(2) *Program alternatives.* If the review of the undertaking is governed by a Federal agency program alternative established under § 800.14 or a programmatic agreement in existence before January 11, 2001, the agency official shall follow the program alternative.

(b) *Coordinate with other reviews.* The agency official should coordinate the steps of the section 106 process, as appropriate, with the overall planning schedule for the undertaking and with any reviews required under other authorities such as the National Environmental Policy Act, the Native American Graves Protection and Repatriation Act, the American Indian Religious Freedom Act, the Archeological Resources Protection Act, and agency-specific legislation, such as section 4(f) of the Department of Transportation Act. Where consistent with the procedures in this subpart, the agency official may use information developed for other reviews under Federal, State, or tribal law to meet the requirements of section 106.

(c) *Identify the appropriate SHPO and/or THPO.* As part of its initial planning, the agency official shall determine the appropriate SHPO or SHPOs to be involved in the section 106 process. The agency official shall also determine whether the undertaking may occur on or affect historic properties on any tribal lands and, if so, whether a THPO has assumed the duties of the SHPO. The agency official shall then

initiate consultation with the appropriate officer or officers.

(1) *Tribal assumption of SHPO responsibilities.* Where an Indian tribe has assumed the section 106 responsibilities of the SHPO on tribal lands pursuant to section 101(d)(2) of the act, consultation for undertakings occurring on tribal land or for effects on tribal land is with the THPO for the Indian tribe in lieu of the SHPO. Section 101(d)(2)(D)(iii) of the act authorizes owners of properties on tribal lands which are neither owned by a member of the tribe nor held in trust by the Secretary for the benefit of the tribe to request the SHPO to participate in the section 106 process in addition to the THPO.

(2) *Undertakings involving more than one State.* If more than one State is involved in an undertaking, the involved SHPOs may agree to designate a lead SHPO to act on their behalf in the section 106 process, including taking actions that would conclude the section 106 process under this subpart.

(3) *Conducting consultation.* The agency official should consult with the SHPO/THPO in a manner appropriate to the agency planning process for the undertaking and to the nature of the undertaking and its effects on historic properties.

(4) *Failure of the SHPO/THPO to respond.* If the SHPO/THPO fails to respond within 30 days of receipt of a request for review of a finding or determination, the agency official may either proceed to the next step in the process based on the finding or determination or consult with the Council in lieu of the SHPO/THPO. If the SHPO/THPO re-enters the Section 106 process, the agency official shall continue the consultation without being required to reconsider previous findings or determinations.

(d) *Consultation on tribal lands.* Where the Indian tribe has not assumed the responsibilities of the SHPO on tribal lands, consultation with the Indian tribe regarding undertakings occurring on such tribe's lands or effects on such tribal lands shall be in addition to and on the same basis as consultation with the SHPO. If the SHPO has withdrawn from the process, the agency official may complete the section 106 process

#### § 800.4

with the Indian tribe and the Council, as appropriate. An Indian tribe may enter into an agreement with a SHPO or SHPOs specifying the SHPO's participation in the section 106 process for undertakings occurring on or affecting historic properties on tribal lands.

(e) *Plan to involve the public.* In consultation with the SHPO/THPO, the agency official shall plan for involving the public in the section 106 process. The agency official shall identify the appropriate points for seeking public input and for notifying the public of proposed actions, consistent with § 800.2(d).

(f) *Identify other consulting parties.* In consultation with the SHPO/THPO, the agency official shall identify any other parties entitled to be consulting parties and invite them to participate as such in the section 106 process. The agency official may invite others to participate as consulting parties as the section 106 process moves forward.

(1) *Involving local governments and applicants.* The agency official shall invite any local governments or applicants that are entitled to be consulting parties under § 800.2(c).

(2) *Involving Indian tribes and Native Hawaiian organizations.* The agency official shall make a reasonable and good faith effort to identify any Indian tribes or Native Hawaiian organizations that might attach religious and cultural significance to historic properties in the area of potential effects and invite them to be consulting parties. Such Indian tribe or Native Hawaiian organization that requests in writing to be a consulting party shall be one.

(3) *Requests to be consulting parties.* The agency official shall consider all written requests of individuals and organizations to participate as consulting parties and, in consultation with the SHPO/THPO and any Indian tribe upon whose tribal lands an undertaking occurs or affects historic properties, determine which should be consulting parties.

(g) *Expediting consultation.* A consultation by the agency official with the SHPO/THPO and other consulting parties may address multiple steps in §§ 800.3 through 800.6 where the agency official and the SHPO/THPO agree it is

#### 36 CFR Ch. VIII (7–1–03 Edition)

appropriate as long as the consulting parties and the public have an adequate opportunity to express their views as provided in § 800.2(d).

#### § 800.4 Identification of historic properties.

(a) *Determine scope of identification efforts.* In consultation with the SHPO/THPO, the agency official shall:

(1) Determine and document the area of potential effects, as defined in § 800.16(d);

(2) Review existing information on historic properties within the area of potential effects, including any data concerning possible historic properties not yet identified;

(3) Seek information, as appropriate, from consulting parties, and other individuals and organizations likely to have knowledge of, or concerns with, historic properties in the area, and identify issues relating to the undertaking's potential effects on historic properties; and

(4) Gather information from any Indian tribe or Native Hawaiian organization identified pursuant to § 800.3(f) to assist in identifying properties, including those located off tribal lands, which may be of religious and cultural significance to them and may be eligible for the National Register, recognizing that an Indian tribe or Native Hawaiian organization may be reluctant to divulge specific information regarding the location, nature, and activities associated with such sites. The agency official should address concerns raised about confidentiality pursuant to § 800.11(c).

(b) *Identify historic properties.* Based on the information gathered under paragraph (a) of this section, and in consultation with the SHPO/THPO and any Indian tribe or Native Hawaiian organization that might attach religious and cultural significance to properties within the area of potential effects, the agency official shall take the steps necessary to identify historic properties within the area of potential effects.

(1) *Level of effort.* The agency official shall make a reasonable and good faith effort to carry out appropriate identification efforts, which may include background research, consultation,



oral history interviews, sample field investigation, and field survey. The agency official shall take into account past planning, research and studies, the magnitude and nature of the undertaking and the degree of Federal involvement, the nature and extent of potential effects on historic properties, and the likely nature and location of historic properties within the area of potential effects. The Secretary's standards and guidelines for identification provide guidance on this subject. The agency official should also consider other applicable professional, State, tribal, and local laws, standards, and guidelines. The agency official shall take into account any confidentiality concerns raised by Indian tribes or Native Hawaiian organizations during the identification process.

(2) *Phased identification and evaluation.* Where alternatives under consideration consist of corridors or large land areas, or where access to properties is restricted, the agency official may use a phased process to conduct identification and evaluation efforts. The agency official may also defer final identification and evaluation of historic properties if it is specifically provided for in a memorandum of agreement executed pursuant to §800.6, a programmatic agreement executed pursuant to §800.14(b), or the documents used by an agency official to comply with the National Environmental Policy Act pursuant to §800.8. The process should establish the likely presence of historic properties within the area of potential effects for each alternative or inaccessible area through background research, consultation and an appropriate level of field investigation, taking into account the number of alternatives under consideration, the magnitude of the undertaking and its likely effects, and the views of the SHPO/THPO and any other consulting parties. As specific aspects or locations of an alternative are refined or access is gained, the agency official shall proceed with the identification and evaluation of historic properties in accordance with paragraphs (b)(1) and (c) of this section.

(c) *Evaluate historic significance.* (1) *Apply National Register criteria.* In consultation with the SHPO/THPO and

any Indian tribe or Native Hawaiian organization that attaches religious and cultural significance to identified properties and guided by the Secretary's standards and guidelines for evaluation, the agency official shall apply the National Register criteria (36 CFR part 63) to properties identified within the area of potential effects that have not been previously evaluated for National Register eligibility. The passage of time, changing perceptions of significance, or incomplete prior evaluations may require the agency official to reevaluate properties previously determined eligible or ineligible. The agency official shall acknowledge that Indian tribes and Native Hawaiian organizations possess special expertise in assessing the eligibility of historic properties that may possess religious and cultural significance to them.

(2) *Determine whether a property is eligible.* If the agency official determines any of the National Register criteria are met and the SHPO/THPO agrees, the property shall be considered eligible for the National Register for section 106 purposes. If the agency official determines the criteria are not met and the SHPO/THPO agrees, the property shall be considered not eligible. If the agency official and the SHPO/THPO do not agree, or if the Council or the Secretary so request, the agency official shall obtain a determination of eligibility from the Secretary pursuant to 36 CFR part 63. If an Indian tribe or Native Hawaiian organization that attaches religious and cultural significance to a property off tribal lands does not agree, it may ask the Council to request the agency official to obtain a determination of eligibility.

(d) *Results of identification and evaluation.* (1) *No historic properties affected.* If the agency official finds that either there are no historic properties present or there are historic properties present but the undertaking will have no effect upon them as defined in §800.16(i), the agency official shall provide documentation of this finding, as set forth in §800.11(d), to the SHPO/THPO. The agency official shall notify all consulting parties, including Indian tribes and Native Hawaiian organizations, and make the documentation available

## § 800.5

## 36 CFR Ch. VIII (7–1–03 Edition)

for public inspection prior to approving the undertaking. If the SHPO/THPO, or the Council if it has entered the section 106 process, does not object within 30 days of receipt of an adequately documented finding, the agency official's responsibilities under section 106 are fulfilled.

(2) *Historic properties affected.* If the agency official finds that there are historic properties which may be affected by the undertaking or the SHPO/THPO or the Council objects to the agency official's finding under paragraph (d)(1) of this section, the agency official shall notify all consulting parties, including Indian tribes or Native Hawaiian organizations, invite their views on the effects and assess adverse effects, if any, in accordance with § 800.5.

### § 800.5 Assessment of adverse effects.

(a) *Apply criteria of adverse effect.* In consultation with the SHPO/THPO and any Indian tribe or Native Hawaiian organization that attaches religious and cultural significance to identified historic properties, the agency official shall apply the criteria of adverse effect to historic properties within the area of potential effects. The agency official shall consider any views concerning such effects which have been provided by consulting parties and the public.

(1) *Criteria of adverse effect.* An adverse effect is found when an undertaking may alter, directly or indirectly, any of the characteristics of a historic property that qualify the property for inclusion in the National Register in a manner that would diminish the integrity of the property's location, design, setting, materials, workmanship, feeling, or association. Consideration shall be given to all qualifying characteristics of a historic property, including those that may have been identified subsequent to the original evaluation of the property's eligibility for the National Register. Adverse effects may include reasonably foreseeable effects caused by the undertaking that may occur later in time, be farther removed in distance or be cumulative.

(2) *Examples of adverse effects.* Adverse effects on historic properties include, but are not limited to:

(i) Physical destruction of or damage to all or part of the property;

(ii) Alteration of a property, including restoration, rehabilitation, repair, maintenance, stabilization, hazardous material remediation, and provision of handicapped access, that is not consistent with the Secretary's standards for the treatment of historic properties (36 CFR part 68) and applicable guidelines;

(iii) Removal of the property from its historic location;

(iv) Change of the character of the property's use or of physical features within the property's setting that contribute to its historic significance;

(v) Introduction of visual, atmospheric or audible elements that diminish the integrity of the property's significant historic features;

(vi) Neglect of a property which causes its deterioration, except where such neglect and deterioration are recognized qualities of a property of religious and cultural significance to an Indian tribe or Native Hawaiian organization; and

(vii) Transfer, lease, or sale of property out of Federal ownership or control without adequate and legally enforceable restrictions or conditions to ensure long-term preservation of the property's historic significance.

(3) *Phased application of criteria.* Where alternatives under consideration consist of corridors or large land areas, or where access to properties is restricted, the agency official may use a phased process in applying the criteria of adverse effect consistent with phased identification and evaluation efforts conducted pursuant to § 800.4(b)(2).

(b) *Finding of no adverse effect.* The agency official, in consultation with the SHPO/THPO, may propose a finding of no adverse effect when the undertaking's effects do not meet the criteria of paragraph (a)(1) of this section or the undertaking is modified or conditions are imposed, such as the subsequent review of plans for rehabilitation by the SHPO/THPO to ensure consistency with the Secretary's standards for the treatment of historic properties (36 CFR part 68) and applicable guidelines, to avoid adverse effects.

(c) *Consulting party review.* If the agency official proposes a finding of no adverse effect, the agency official shall notify all consulting parties of the finding and provide them with the documentation specified in § 800.11(e). The SHPO/THPO shall have 30 days from receipt to review the finding.

(1) *Agreement with finding.* Unless the Council is reviewing the finding pursuant to § 800.5(c)(3), the agency official may proceed if the SHPO/THPO agrees with the finding. The agency official shall carry out the undertaking in accordance with § 800.5(d)(1). Failure of the SHPO/THPO to respond within 30 days from receipt of the finding shall be considered agreement of the SHPO/THPO with the finding.

(2) *Disagreement with finding.* (i) If the SHPO/THPO or any consulting party disagrees within the 30-day review period, it shall specify the reasons for disagreeing with the finding. The agency official shall either consult with the party to resolve the disagreement, or request the Council to review the finding pursuant to paragraph (c)(3) of this section.

(ii) The agency official should seek the concurrence of any Indian tribe or Native Hawaiian organization that has made known to the agency official that it attaches religious and cultural significance to a historic property subject to the finding. If such Indian tribe or Native Hawaiian organization disagrees with the finding, it may within the 30-day review period specify the reasons for disagreeing with the finding and request the Council to review the finding pursuant to paragraph (c)(3) of this section.

(iii) If the Council on its own initiative so requests within the 30-day review period, the agency official shall submit the finding, along with the documentation specified in § 800.11(e), for review pursuant to paragraph (c)(3) of this section. A Council decision to make such a request shall be guided by the criteria in appendix A to this part.

(3) *Council review of findings.* When a finding is submitted to the Council pursuant to paragraph (c)(2) of this section, the agency official shall include the documentation specified in § 800.11(e). The Council shall review the finding and notify the agency official

of its determination as to whether the adverse effect criteria have been correctly applied within 15 days of receiving the documented finding from the agency official. The Council shall specify the basis for its determination. The agency official shall proceed in accordance with the Council's determination. If the Council does not respond within 15 days of receipt of the finding, the agency official may assume concurrence with the agency official's findings and proceed accordingly.

(d) *Results of assessment.* (1) *No adverse effect.* The agency official shall maintain a record of the finding and provide information on the finding to the public on request, consistent with the confidentiality provisions of § 800.11(c). Implementation of the undertaking in accordance with the finding as documented fulfills the agency official's responsibilities under section 106 and this part. If the agency official will not conduct the undertaking as proposed in the finding, the agency official shall reopen consultation under paragraph (a) of this section.

(2) *Adverse effect.* If an adverse effect is found, the agency official shall consult further to resolve the adverse effect pursuant to § 800.6.

#### § 800.6 Resolution of adverse effects.

(a) *Continue consultation.* The agency official shall consult with the SHPO/THPO and other consulting parties, including Indian tribes and Native Hawaiian organizations, to develop and evaluate alternatives or modifications to the undertaking that could avoid, minimize, or mitigate adverse effects on historic properties.

(1) *Notify the Council and determine Council participation.* The agency official shall notify the Council of the adverse effect finding by providing the documentation specified in § 800.11(e).

(i) The notice shall invite the Council to participate in the consultation when:

(A) The agency official wants the Council to participate;

(B) The undertaking has an adverse effect upon a National Historic Landmark; or

(C) A programmatic agreement under § 800.14(b) will be prepared;

## § 800.6

## 36 CFR Ch. VIII (7–1–03 Edition)

(ii) The SHPO/THPO, an Indian tribe or Native Hawaiian organization, or any other consulting party may at any time independently request the Council to participate in the consultation.

(iii) The Council shall advise the agency official and all consulting parties whether it will participate within 15 days of receipt of notice or other request. Prior to entering the process, the Council shall provide written notice to the agency official and the consulting parties that its decision to participate meets the criteria set forth in appendix A to this part. The Council shall also advise the head of the agency of its decision to enter the process. Consultation with Council participation is conducted in accordance with paragraph (b)(2) of this section.

(iv) If the Council does not join the consultation, the agency official shall proceed with consultation in accordance with paragraph (b)(1) of this section.

(2) *Involve consulting parties.* In addition to the consulting parties identified under § 800.3(f), the agency official, the SHPO/THPO and the Council, if participating, may agree to invite other individuals or organizations to become consulting parties. The agency official shall invite any individual or organization that will assume a specific role or responsibility in a memorandum of agreement to participate as a consulting party.

(3) *Provide documentation.* The agency official shall provide to all consulting parties the documentation specified in § 800.11(e), subject to the confidentiality provisions of § 800.11(c), and such other documentation as may be developed during the consultation to resolve adverse effects.

(4) *Involve the public.* The agency official shall make information available to the public, including the documentation specified in § 800.11(e), subject to the confidentiality provisions of § 800.11(c). The agency official shall provide an opportunity for members of the public to express their views on resolving adverse effects of the undertaking. The agency official should use appropriate mechanisms, taking into account the magnitude of the undertaking and the nature of its effects upon historic properties, the likely ef-

fects on historic properties, and the relationship of the Federal involvement to the undertaking to ensure that the public's views are considered in the consultation. The agency official should also consider the extent of notice and information concerning historic preservation issues afforded the public at earlier steps in the section 106 process to determine the appropriate level of public involvement when resolving adverse effects so that the standards of § 800.2(d) are met.

(5) *Restrictions on disclosure of information.* Section 304 of the act and other authorities may limit the disclosure of information under paragraphs (a)(3) and (a)(4) of this section. If an Indian tribe or Native Hawaiian organization objects to the disclosure of information or if the agency official believes that there are other reasons to withhold information, the agency official shall comply with § 800.11(c) regarding the disclosure of such information.

(b) *Resolve adverse effects.* (1) *Resolution without the Council.*

(i) The agency official shall consult with the SHPO/THPO and other consulting parties to seek ways to avoid, minimize or mitigate the adverse effects.

(ii) The agency official may use standard treatments established by the Council under § 800.14(d) as a basis for a memorandum of agreement.

(iii) If the Council decides to join the consultation, the agency official shall follow paragraph (b)(2) of this section.

(iv) If the agency official and the SHPO/THPO agree on how the adverse effects will be resolved, they shall execute a memorandum of agreement. The agency official must submit a copy of the executed memorandum of agreement, along with the documentation specified in § 800.11(f), to the Council prior to approving the undertaking in order to meet the requirements of section 106 and this subpart.

(v) If the agency official, and the SHPO/THPO fail to agree on the terms of a memorandum of agreement, the agency official shall request the Council to join the consultation and provide the Council with the documentation set forth in § 800.11(g). If the Council decides to join the consultation, the

agency official shall proceed in accordance with paragraph (b)(2) of this section. If the Council decides not to join the consultation, the Council will notify the agency and proceed to comment in accordance with §800.7(c).

(2) *Resolution with Council participation.* If the Council decides to participate in the consultation, the agency official shall consult with the SHPO/THPO, the Council, and other consulting parties, including Indian tribes and Native Hawaiian organizations under §800.2(c)(3), to seek ways to avoid, minimize or mitigate the adverse effects. If the agency official, the SHPO/THPO, and the Council agree on how the adverse effects will be resolved, they shall execute a memorandum of agreement.

(c) *Memorandum of agreement.* A memorandum of agreement executed and implemented pursuant to this section evidences the agency official's compliance with section 106 and this part and shall govern the undertaking and all of its parts. The agency official shall ensure that the undertaking is carried out in accordance with the memorandum of agreement.

(1) *Signatories.* The signatories have sole authority to execute, amend or terminate the agreement in accordance with this subpart.

(i) The agency official and the SHPO/THPO are the signatories to a memorandum of agreement executed pursuant to paragraph (b)(1) of this section.

(ii) The agency official, the SHPO/THPO, and the Council are the signatories to a memorandum of agreement executed pursuant to paragraph (b)(2) of this section.

(iii) The agency official and the Council are signatories to a memorandum of agreement executed pursuant to §800.7(a)(2).

(2) *Invited signatories.* (i) The agency official may invite additional parties to be signatories to a memorandum of agreement. Any such party that signs the memorandum of agreement shall have the same rights with regard to seeking amendment or termination of the memorandum of agreement as other signatories.

(ii) The agency official may invite an Indian tribe or Native Hawaiian organization that attaches religious and

cultural significance to historic properties located off tribal lands to be a signatory to a memorandum of agreement concerning such properties.

(iii) The agency official should invite any party that assumes a responsibility under a memorandum of agreement to be a signatory.

(iv) The refusal of any party invited to become a signatory to a memorandum of agreement pursuant to paragraph (c)(2) of this section does not invalidate the memorandum of agreement.

(3) *Concurrence by others.* The agency official may invite all consulting parties to concur in the memorandum of agreement. The signatories may agree to invite others to concur. The refusal of any party invited to concur in the memorandum of agreement does not invalidate the memorandum of agreement.

(4) *Reports on implementation.* Where the signatories agree it is appropriate, a memorandum of agreement shall include a provision for monitoring and reporting on its implementation.

(5) *Duration.* A memorandum of agreement shall include provisions for termination and for reconsideration of terms if the undertaking has not been implemented within a specified time.

(6) *Discoveries.* Where the signatories agree it is appropriate, a memorandum of agreement shall include provisions to deal with the subsequent discovery or identification of additional historic properties affected by the undertaking.

(7) *Amendments.* The signatories to a memorandum of agreement may amend it. If the Council was not a signatory to the original agreement and the signatories execute an amended agreement, the agency official shall file it with the Council.

(8) *Termination.* If any signatory determines that the terms of a memorandum of agreement cannot be or are not being carried out, the signatories shall consult to seek amendment of the agreement. If the agreement is not amended, any signatory may terminate it. The agency official shall either execute a memorandum of agreement with signatories under paragraph (c)(1) of this section or request the comments of the Council under §800.7(a).

## § 800.7

(9) *Copies.* The agency official shall provide each consulting party with a copy of any memorandum of agreement executed pursuant to this subpart.

### § 800.7 Failure to resolve adverse effects.

(a) *Termination of consultation.* After consulting to resolve adverse effects pursuant to § 800.6(b)(2), the agency official, the SHPO/THPO, or the Council may determine that further consultation will not be productive and terminate consultation. Any party that terminates consultation shall notify the other consulting parties and provide them the reasons for terminating in writing.

(1) If the agency official terminates consultation, the head of the agency or an Assistant Secretary or other officer with major department-wide or agency-wide responsibilities shall request that the Council comment pursuant to paragraph (c) of this section and shall notify all consulting parties of the request.

(2) If the SHPO terminates consultation, the agency official and the Council may execute a memorandum of agreement without the SHPO's involvement.

(3) If a THPO terminates consultation regarding an undertaking occurring on or affecting historic properties on its tribal lands, the Council shall comment pursuant to paragraph (c) of this section.

(4) If the Council terminates consultation, the Council shall notify the agency official, the agency's Federal preservation officer and all consulting parties of the termination and comment under paragraph (c) of this section. The Council may consult with the agency's Federal preservation officer prior to terminating consultation to seek to resolve issues concerning the undertaking and its effects on historic properties.

(b) *Comments without termination.* The Council may determine that it is appropriate to provide additional advisory comments upon an undertaking for which a memorandum of agreement will be executed. The Council shall provide them to the agency official when it executes the memorandum of agreement.

## 36 CFR Ch. VIII (7–1–03 Edition)

(c) *Comments by the Council.* (1) *Preparation.* The Council shall provide an opportunity for the agency official, all consulting parties, and the public to provide their views within the time frame for developing its comments. Upon request of the Council, the agency official shall provide additional existing information concerning the undertaking and assist the Council in arranging an onsite inspection and an opportunity for public participation.

(2) *Timing.* The Council shall transmit its comments within 45 days of receipt of a request under paragraph (a)(1) or (a)(3) of this section or § 800.8(c)(3), or termination by the Council under § 800.6(b)(1)(v) or paragraph (a)(4) of this section, unless otherwise agreed to by the agency official.

(3) *Transmittal.* The Council shall provide its comments to the head of the agency requesting comment with copies to the agency official, the agency's Federal preservation officer, all consulting parties, and others as appropriate.

(4) *Response to Council comment.* The head of the agency shall take into account the Council's comments in reaching a final decision on the undertaking. Section 110(l) of the act directs that the head of the agency shall document this decision and may not delegate his or her responsibilities pursuant to section 106. Documenting the agency head's decision shall include:

(i) Preparing a summary of the decision that contains the rationale for the decision and evidence of consideration of the Council's comments and providing it to the Council prior to approval of the undertaking;

(ii) Providing a copy of the summary to all consulting parties; and

(iii) Notifying the public and making the record available for public inspection.

### § 800.8 Coordination With the National Environmental Policy Act.

(a) *General principles.* (1) *Early coordination.* Federal agencies are encouraged to coordinate compliance with section 106 and the procedures in this part with any steps taken to meet the requirements of the National Environmental Policy Act (NEPA). Agencies

should consider their section 106 responsibilities as early as possible in the NEPA process, and plan their public participation, analysis, and review in such a way that they can meet the purposes and requirements of both statutes in a timely and efficient manner. The determination of whether an undertaking is a “major Federal action significantly affecting the quality of the human environment,” and therefore requires preparation of an environmental impact statement (EIS) under NEPA, should include consideration of the undertaking’s likely effects on historic properties. A finding of adverse effect on a historic property does not necessarily require an EIS under NEPA.

(2) *Consulting party roles.* SHPO/THPOs, Indian tribes, and Native Hawaiian organizations, other consulting parties, and organizations and individuals who may be concerned with the possible effects of an agency action on historic properties should be prepared to consult with agencies early in the NEPA process, when the purpose of and need for the proposed action as well as the widest possible range of alternatives are under consideration.

(3) *Inclusion of historic preservation issues.* Agency officials should ensure that preparation of an environmental assessment (EA) and finding of no significant impact (FONSI) or an EIS and record of decision (ROD) includes appropriate scoping, identification of historic properties, assessment of effects upon them, and consultation leading to resolution of any adverse effects.

(b) *Actions categorically excluded under NEPA.* If a project, activity or program is categorically excluded from NEPA review under an agency’s NEPA procedures, the agency official shall determine if it still qualifies as an undertaking requiring review under section 106 pursuant to §800.3(a). If so, the agency official shall proceed with section 106 review in accordance with the procedures in this subpart.

(c) *Use of the NEPA process for section 106 purposes.* An agency official may use the process and documentation required for the preparation of an EA/FONSI or an EIS/ROD to comply with section 106 in lieu of the procedures set forth in §§800.3 through 800.6 if the

agency official has notified in advance the SHPO/THPO and the Council that it intends to do so and the following standards are met.

(1) *Standards for developing environmental documents to comply with Section 106.* During preparation of the EA or draft EIS (DEIS) the agency official shall:

(i) Identify consulting parties either pursuant to §800.3(f) or through the NEPA scoping process with results consistent with §800.3(f);

(ii) Identify historic properties and assess the effects of the undertaking on such properties in a manner consistent with the standards and criteria of §§800.4 through 800.5, provided that the scope and timing of these steps may be phased to reflect the agency official’s consideration of project alternatives in the NEPA process and the effort is commensurate with the assessment of other environmental factors;

(iii) Consult regarding the effects of the undertaking on historic properties with the SHPO/THPO, Indian tribes, and Native Hawaiian organizations that might attach religious and cultural significance to affected historic properties, other consulting parties, and the Council, where appropriate, during NEPA scoping, environmental analysis, and the preparation of NEPA documents;

(iv) Involve the public in accordance with the agency’s published NEPA procedures; and (v) Develop in consultation with identified consulting parties alternatives and proposed measures that might avoid, minimize or mitigate any adverse effects of the undertaking on historic properties and describe them in the EA or DEIS.

(2) *Review of environmental documents.*

(i) The agency official shall submit the EA, DEIS, or EIS to the SHPO/THPO, Indian tribes, and Native Hawaiian organizations that might attach religious and cultural significance to affected historic properties, and other consulting parties prior to or when making the document available for public comment. If the document being prepared is a DEIS or EIS, the agency official shall also submit it to the Council.

(ii) Prior to or within the time allowed for public comment on the document, a SHPO/THPO, an Indian tribe or

## § 800.9

## 36 CFR Ch. VIII (7–1–03 Edition)

Native Hawaiian organization, another consulting party or the Council may object to the agency official that preparation of the EA, DEIS, or EIS has not met the standards set forth in paragraph (c)(1) of this section or that the substantive resolution of the effects on historic properties proposed in an EA, DEIS, or EIS is inadequate. If the agency official receives such an objection, the agency official shall refer the matter to the Council.

(3) *Resolution of objections.* Within 30 days of the agency official's referral of an objection under paragraph (c)(2)(ii) of this section, the Council shall notify the agency official either that it agrees with the objection, in which case the agency official shall enter into consultation in accordance with § 800.6(b)(2) or seek Council comments in accordance with § 800.7(a), or that it disagrees with the objection, in which case the agency official shall continue its compliance with this section. Failure of the Council to respond within the 30 day period shall be considered disagreement with the objection.

(4) *Approval of the undertaking.* If the agency official has found, during the preparation of an EA or EIS that the effects of an undertaking on historic properties are adverse, the agency official shall develop measures in the EA, DEIS, or EIS to avoid, minimize, or mitigate such effects in accordance with paragraph (c)(1)(v) of this section. The agency official's responsibilities under section 106 and the procedures in this subpart shall then be satisfied when either:

(i) A binding commitment to such proposed measures is incorporated in:

(A) The ROD, if such measures were proposed in a DEIS or EIS; or

(B) An MOA drafted in compliance with § 800.6(c); or

(ii) The Council has commented under § 800.7 and received the agency's response to such comments.

(5) *Modification of the undertaking.* If the undertaking is modified after approval of the FONSI or the ROD in a manner that changes the undertaking or alters its effects on historic properties, or if the agency official fails to ensure that the measures to avoid, minimize or mitigate adverse effects (as specified in either the FONSI or the

ROD, or in the binding commitment adopted pursuant to paragraph (c)(4) of this section) are carried out, the agency official shall notify the Council and all consulting parties that supplemental environmental documents will be prepared in compliance with NEPA or that the procedures in §§ 800.3 through 800.6 will be followed as necessary.

### § 800.9 Council review of section 106 compliance.

(a) *Assessment of agency official compliance for individual undertakings.* The Council may provide to the agency official its advisory opinion regarding the substance of any finding, determination or decision or regarding the adequacy of the agency official's compliance with the procedures under this part. The Council may provide such advice at any time at the request of any individual, agency or organization or on its own initiative. The agency official shall consider the views of the Council in reaching a decision on the matter in question.

(b) *Agency foreclosure of the Council's opportunity to comment.* Where an agency official has failed to complete the requirements of section 106 in accordance with the procedures in this part prior to the approval of an undertaking, the Council's opportunity to comment may be foreclosed. The Council may review a case to determine whether a foreclosure has occurred. The Council shall notify the agency official and the agency's Federal preservation officer and allow 30 days for the agency official to provide information as to whether foreclosure has occurred. If the Council determines foreclosure has occurred, the Council shall transmit the determination to the agency official and the head of the agency. The Council shall also make the determination available to the public and any parties known to be interested in the undertaking and its effects upon historic properties.

(c) *Intentional adverse effects by applicants.* (1) *Agency responsibility.* Section 110(k) of the act prohibits a Federal agency from granting a loan, loan



guarantee, permit, license or other assistance to an applicant who, with intent to avoid the requirements of section 106, has intentionally significantly adversely affected a historic property to which the grant would relate, or having legal power to prevent it, has allowed such significant adverse effect to occur, unless the agency, after consultation with the Council, determines that circumstances justify granting such assistance despite the adverse effect created or permitted by the applicant. Guidance issued by the Secretary pursuant to section 110 of the act governs its implementation.

(2) *Consultation with the Council.* When an agency official determines, based on the actions of an applicant, that section 110(k) is applicable and that circumstances may justify granting the assistance, the agency official shall notify the Council and provide documentation specifying the circumstances under which the adverse effects to the historic property occurred and the degree of damage to the integrity of the property. This documentation shall include any views obtained from the applicant, SHPO/THPO, an Indian tribe if the undertaking occurs on or affects historic properties on tribal lands, and other parties known to be interested in the undertaking.

(i) Within thirty days of receiving the agency official's notification, unless otherwise agreed to by the agency official, the Council shall provide the agency official with its opinion as to whether circumstances justify granting assistance to the applicant and any possible mitigation of the adverse effects.

(ii) The agency official shall consider the Council's opinion in making a decision on whether to grant assistance to the applicant, and shall notify the Council, the SHPO/THPO, and other parties known to be interested in the undertaking prior to granting the assistance.

(3) *Compliance with Section 106.* If an agency official, after consulting with the Council, determines to grant the assistance, the agency official shall comply with §§800.3 through 800.6 to take into account the effects of the undertaking on any historic properties.

(d) *Evaluation of Section 106 operations.* The Council may evaluate the operation of the section 106 process by periodic reviews of how participants have fulfilled their legal responsibilities and how effectively the outcomes reached advance the purposes of the act.

(1) *Information from participants.* Section 203 of the act authorizes the Council to obtain information from Federal agencies necessary to conduct evaluation of the section 106 process. The agency official shall make documentation of agency policies, operating procedures and actions taken to comply with section 106 available to the Council upon request. The Council may request available information and documentation from other participants in the section 106 process.

(2) *Improving the operation of section 106.* Based upon any evaluation of the section 106 process, the Council may make recommendations to participants, the heads of Federal agencies, and the Secretary of actions to improve the efficiency and effectiveness of the process. Where the Council determines that an agency official or a SHPO/THPO has failed to properly carry out the responsibilities assigned under the process in this part, the Council may participate in individual case reviews conducted under such process in addition to the SHPO/THPO for such period that it determines is necessary to improve performance or correct deficiencies. If the Council finds a pattern of failure by a Federal agency in carrying out its responsibilities under section 106, the Council may review the policies and programs of the agency related to historic preservation pursuant to section 202(a)(6) of the act and recommend methods to improve the effectiveness, coordination, and consistency of those policies and programs with section 106.

**§800.10 Special requirements for protecting National Historic Landmarks.**

(a) *Statutory requirement.* Section 110(f) of the act requires that the agency official, to the maximum extent possible, undertake such planning and actions as may be necessary to minimize harm to any National Historic

## § 800.11

## 36 CFR Ch. VIII (7–1–03 Edition)

Landmark that may be directly and adversely affected by an undertaking. When commenting on such undertakings, the Council shall use the process set forth in §§ 800.6 through 800.7 and give special consideration to protecting National Historic Landmarks as specified in this section.

(b) *Resolution of adverse effects.* The agency official shall request the Council to participate in any consultation to resolve adverse effects on National Historic Landmarks conducted under § 800.6.

(c) *Involvement of the Secretary.* The agency official shall notify the Secretary of any consultation involving a National Historic Landmark and invite the Secretary to participate in the consultation where there may be an adverse effect. The Council may request a report from the Secretary under section 213 of the act to assist in the consultation.

(d) *Report of outcome.* When the Council participates in consultation under this section, it shall report the outcome of the section 106 process, providing its written comments or any memoranda of agreement to which it is a signatory, to the Secretary and the head of the agency responsible for the undertaking.

### § 800.11 Documentation standards.

(a) *Adequacy of documentation.* The agency official shall ensure that a determination, finding, or agreement under the procedures in this subpart is supported by sufficient documentation to enable any reviewing parties to understand its basis. The agency official shall provide such documentation to the extent permitted by law and within available funds. When an agency official is conducting phased identification or evaluation under this subpart, the documentation standards regarding description of historic properties may be applied flexibly. If the Council, or the SHPO/THPO when the Council is not involved, determines the applicable documentation standards are not met, the Council or the SHPO/THPO, as appropriate, shall notify the agency official and specify the information needed to meet the standard. At the request of the agency official or any of the consulting parties, the Council shall re-

view any disputes over whether documentation standards are met and provide its views to the agency official and the consulting parties.

(b) *Format.* The agency official may use documentation prepared to comply with other laws to fulfill the requirements of the procedures in this subpart, if that documentation meets the standards of this section.

(c) *Confidentiality.* (1) *Authority to withhold information.* Section 304 of the act provides that the head of a Federal agency or other public official receiving grant assistance pursuant to the act, after consultation with the Secretary, shall withhold from public disclosure information about the location, character, or ownership of a historic property when disclosure may cause a significant invasion of privacy; risk harm to the historic property; or impede the use of a traditional religious site by practitioners. When the head of a Federal agency or other public official has determined that information should be withheld from the public pursuant to these criteria, the Secretary, in consultation with such Federal agency head or official, shall determine who may have access to the information for the purposes of carrying out the act.

(2) *Consultation with the Council.* When the information in question has been developed in the course of an agency's compliance with this part, the Secretary shall consult with the Council in reaching determinations on the withholding and release of information. The Federal agency shall provide the Council with available information, including views of the SHPO/THPO, Indian tribes and Native Hawaiian organizations, related to the confidentiality concern. The Council shall advise the Secretary and the Federal agency within 30 days of receipt of adequate documentation.

(3) *Other authorities affecting confidentiality.* Other Federal laws and program requirements may limit public access to information concerning an undertaking and its effects on historic properties. Where applicable, those authorities shall govern public access to information developed in the section 106 process and may authorize the agency

## Advisory Council on Historic Preservation

## § 800.12

official to protect the privacy of non-governmental applicants.

(d) *Finding of no historic properties affected.* Documentation shall include:

(1) A description of the undertaking, specifying the Federal involvement, and its area of potential effects, including photographs, maps, drawings, as necessary;

(2) A description of the steps taken to identify historic properties, including, as appropriate, efforts to seek information pursuant to § 800.4(b); and

(3) The basis for determining that no historic properties are present or affected.

(e) *Finding of no adverse effect or adverse effect.* Documentation shall include:

(1) A description of the undertaking, specifying the Federal involvement, and its area of potential effects, including photographs, maps, and drawings, as necessary;

(2) A description of the steps taken to identify historic properties;

(3) A description of the affected historic properties, including information on the characteristics that qualify them for the National Register;

(4) A description of the undertaking's effects on historic properties;

(5) An explanation of why the criteria of adverse effect were found applicable or inapplicable, including any conditions or future actions to avoid, minimize or mitigate adverse effects; and

(6) Copies or summaries of any views provided by consulting parties and the public.

(f) *Memorandum of agreement.* When a memorandum of agreement is filed with the Council, the documentation shall include, any substantive revisions or additions to the documentation provided the Council pursuant to § 800.6(a)(1), an evaluation of any measures considered to avoid or minimize the undertaking's adverse effects and a summary of the views of consulting parties and the public.

(g) *Requests for comment without a memorandum of agreement.* Documentation shall include:

(1) A description and evaluation of any alternatives or mitigation measures that the agency official proposes to resolve the undertaking's adverse effects;

(2) A description of any reasonable alternatives or mitigation measures that were considered but not chosen, and the reasons for their rejection;

(3) Copies or summaries of any views submitted to the agency official concerning the adverse effects of the undertaking on historic properties and alternatives to reduce or avoid those effects; and

(4) Any substantive revisions or additions to the documentation provided the Council pursuant to § 800.6(a)(1).

### § 800.12 Emergency situations.

(a) *Agency procedures.* The agency official, in consultation with the appropriate SHPOs/THPOs, affected Indian tribes and Native Hawaiian organizations, and the Council, is encouraged to develop procedures for taking historic properties into account during operations which respond to a disaster or emergency declared by the President, a tribal government, or the Governor of a State or which respond to other immediate threats to life or property. If approved by the Council, the procedures shall govern the agency's historic preservation responsibilities during any disaster or emergency in lieu of §§ 800.3 through 800.6.

(b) *Alternatives to agency procedures.* In the event an agency official proposes an emergency undertaking as an essential and immediate response to a disaster or emergency declared by the President, a tribal government, or the Governor of a State or another immediate threat to life or property, and the agency has not developed procedures pursuant to paragraph (a) of this section, the agency official may comply with section 106 by:

(1) Following a programmatic agreement developed pursuant to § 800.14(b) that contains specific provisions for dealing with historic properties in emergency situations; or

(2) Notifying the Council, the appropriate SHPO/THPO and any Indian tribe or Native Hawaiian organization that may attach religious and cultural significance to historic properties likely to be affected prior to the undertaking and affording them an opportunity to comment within seven days of notification. If the agency official determines that circumstances do not

permit seven days for comment, the agency official shall notify the Council, the SHPO/THPO and the Indian tribe or Native Hawaiian organization and invite any comments within the time available.

(c) *Local governments responsible for section 106 compliance.* When a local government official serves as the agency official for section 106 compliance, paragraphs (a) and (b) of this section also apply to an imminent threat to public health or safety as a result of a natural disaster or emergency declared by a local government's chief executive officer or legislative body, provided that if the Council or SHPO/THPO objects to the proposed action within seven days, the agency official shall comply with §§ 800.3 through 800.6.

(d) *Applicability.* This section applies only to undertakings that will be implemented within 30 days after the disaster or emergency has been formally declared by the appropriate authority. An agency may request an extension of the period of applicability from the Council prior to the expiration of the 30 days. Immediate rescue and salvage operations conducted to preserve life or property are exempt from the provisions of section 106 and this part.

#### § 800.13 Post-review discoveries.

(a) *Planning for subsequent discoveries.*

(1) *Using a programmatic agreement.* An agency official may develop a programmatic agreement pursuant to § 800.14(b) to govern the actions to be taken when historic properties are discovered during the implementation of an undertaking.

(2) *Using agreement documents.* When the agency official's identification efforts in accordance with § 800.4 indicate that historic properties are likely to be discovered during implementation of an undertaking and no programmatic agreement has been developed pursuant to paragraph (a)(1) of this section, the agency official shall include in any finding of no adverse effect or memorandum of agreement a process to resolve any adverse effects upon such properties. Actions in conformance with the process satisfy the agency official's responsibilities under section 106 and this part.

(b) *Discoveries without prior planning.*

If historic properties are discovered or unanticipated effects on historic properties found after the agency official has completed the section 106 process without establishing a process under paragraph (a) of this section, the agency official shall make reasonable efforts to avoid, minimize or mitigate adverse effects to such properties and:

(1) If the agency official has not approved the undertaking or if construction on an approved undertaking has not commenced, consult to resolve adverse effects pursuant to § 800.6; or

(2) If the agency official, the SHPO/THPO and any Indian tribe or Native Hawaiian organization that might attach religious and cultural significance to the affected property agree that such property is of value solely for its scientific, prehistoric, historic or archeological data, the agency official may comply with the Archeological and Historic Preservation Act instead of the procedures in this part and provide the Council, the SHPO/THPO, and the Indian tribe or Native Hawaiian organization with a report on the actions within a reasonable time after they are completed; or

(3) If the agency official has approved the undertaking and construction has commenced, determine actions that the agency official can take to resolve adverse effects, and notify the SHPO/THPO, any Indian tribe or Native Hawaiian organization that might attach religious and cultural significance to the affected property, and the Council within 48 hours of the discovery. The notification shall describe the agency official's assessment of National Register eligibility of the property and proposed actions to resolve the adverse effects. The SHPO/THPO, the Indian tribe or Native Hawaiian organization and the Council shall respond within 48 hours of the notification. The agency official shall take into account their recommendations regarding National Register eligibility and proposed actions, and then carry out appropriate actions. The agency official shall provide the SHPO/THPO, the Indian tribe or Native Hawaiian organization and the Council a report of the actions when they are completed.

(c) *Eligibility of properties.* The agency official, in consultation with the SHPO/THPO, may assume a newly-discovered property to be eligible for the National Register for purposes of section 106. The agency official shall specify the National Register criteria used to assume the property's eligibility so that information can be used in the resolution of adverse effects.

(d) *Discoveries on tribal lands.* If historic properties are discovered on tribal lands, or there are unanticipated effects on historic properties found on tribal lands, after the agency official has completed the section 106 process without establishing a process under paragraph (a) of this section and construction has commenced, the agency official shall comply with applicable tribal regulations and procedures and obtain the concurrence of the Indian tribe on the proposed action.

### Subpart C—Program Alternatives

#### § 800.14 Federal agency program alternatives.

(a) *Alternate procedures.* An agency official may develop procedures to implement section 106 and substitute them for all or part of subpart B of this part if they are consistent with the Council's regulations pursuant to section 110(a)(2)(E) of the act.

(1) *Development of procedures.* The agency official shall consult with the Council, the National Conference of State Historic Preservation Officers, or individual SHPO/THPOs, as appropriate, and Indian tribes and Native Hawaiian organizations, as specified in paragraph (f) of this section, in the development of alternate procedures, publish notice of the availability of proposed alternate procedures in the FEDERAL REGISTER and take other appropriate steps to seek public input during the development of alternate procedures.

(2) *Council review.* The agency official shall submit the proposed alternate procedures to the Council for a 60-day review period. If the Council finds the procedures to be consistent with this part, it shall notify the agency official and the agency official may adopt them as final alternate procedures.

(3) *Notice.* The agency official shall notify the parties with which it has consulted and publish notice of final alternate procedures in the FEDERAL REGISTER.

(4) *Legal effect.* Alternate procedures adopted pursuant to this subpart substitute for the Council's regulations for the purposes of the agency's compliance with section 106, except that where an Indian tribe has entered into an agreement with the Council to substitute tribal historic preservation regulations for the Council's regulations under section 101(d)(5) of the act, the agency shall follow those regulations in lieu of the agency's procedures regarding undertakings on tribal lands. Prior to the Council entering into such agreements, the Council will provide Federal agencies notice and opportunity to comment on the proposed substitute tribal regulations.

(b) *Programmatic agreements.* The Council and the agency official may negotiate a programmatic agreement to govern the implementation of a particular program or the resolution of adverse effects from certain complex project situations or multiple undertakings.

(1) *Use of programmatic agreements.* A programmatic agreement may be used:

(i) When effects on historic properties are similar and repetitive or are multi-State or regional in scope;

(ii) When effects on historic properties cannot be fully determined prior to approval of an undertaking;

(iii) When nonfederal parties are delegated major decisionmaking responsibilities;

(iv) Where routine management activities are undertaken at Federal installations, facilities, or other land-management units; or

(v) Where other circumstances warrant a departure from the normal section 106 process.

(2) *Developing programmatic agreements for agency programs.*

(i) The consultation shall involve, as appropriate, SHPO/THPOs, the National Conference of State Historic Preservation Officers (NCSHPO), Indian tribes and Native Hawaiian organizations, other Federal agencies, and

members of the public. If the programmatic agreement has the potential to affect historic properties on tribal lands or historic properties of religious and cultural significance to an Indian tribe or Native Hawaiian organization, the agency official shall also follow paragraph (f) of this section.

(ii) *Public participation.* The agency official shall arrange for public participation appropriate to the subject matter and the scope of the program and in accordance with subpart A of this part. The agency official shall consider the nature of the program and its likely effects on historic properties and take steps to involve the individuals, organizations and entities likely to be interested.

(iii) *Effect.* The programmatic agreement shall take effect when executed by the Council, the agency official and the appropriate SHPOs/THPOs when the programmatic agreement concerns a specific region or the president of NCSHPO when NCSHPO has participated in the consultation. A programmatic agreement shall take effect on tribal lands only when the THPO, Indian tribe, or a designated representative of the tribe is a signatory to the agreement. Compliance with the procedures established by an approved programmatic agreement satisfies the agency's section 106 responsibilities for all individual undertakings of the program covered by the agreement until it expires or is terminated by the agency, the president of NCSHPO when a signatory, or the Council. Termination by an individual SHPO/THPO shall only terminate the application of a regional programmatic agreement within the jurisdiction of the SHPO/THPO. If a THPO assumes the responsibilities of a SHPO pursuant to section 101(d)(2) of the act and the SHPO is signatory to programmatic agreement, the THPO assumes the role of a signatory, including the right to terminate a regional programmatic agreement on lands under the jurisdiction of the tribe.

(iv) *Notice.* The agency official shall notify the parties with which it has consulted that a programmatic agreement has been executed under paragraph (b) of this section, provide appropriate public notice before it takes effect, and make any internal agency

procedures implementing the agreement readily available to the Council, SHPO/THPOs, and the public.

(v) If the Council determines that the terms of a programmatic agreement are not being carried out, or if such an agreement is terminated, the agency official shall comply with subpart B of this part with regard to individual undertakings of the program covered by the agreement.

(3) *Developing programmatic agreements for complex or multiple undertakings.* Consultation to develop a programmatic agreement for dealing with the potential adverse effects of complex projects or multiple undertakings shall follow §800.6. If consultation pertains to an activity involving multiple undertakings and the parties fail to reach agreement, then the agency official shall comply with the provisions of subpart B of this part for each individual undertaking.

(4) *Prototype programmatic agreements.* The Council may designate an agreement document as a prototype programmatic agreement that may be used for the same type of program or undertaking in more than one case or area. When an agency official uses such a prototype programmatic agreement, the agency official may develop and execute the agreement with the appropriate SHPO/THPO and the agreement shall become final without need for Council participation in consultation or Council signature.

(c) *Exempted categories.* (1) *Criteria for establishing.* An agency official may propose a program or category of agency undertakings that may be exempted from review under the provisions of subpart B of this part, if the program or category meets the following criteria:

(i) The actions within the program or category would otherwise qualify as "undertakings" as defined in §800.16;

(ii) The potential effects of the undertakings within the program or category upon historic properties are foreseeable and likely to be minimal or not adverse; and

(iii) Exemption of the program or category is consistent with the purposes of the act.

(2) *Public participation.* The agency official shall arrange for public participation appropriate to the subject matter and the scope of the exemption and in accordance with the standards in subpart A of this part. The agency official shall consider the nature of the exemption and its likely effects on historic properties and take steps to involve individuals, organizations and entities likely to be interested.

(3) *Consultation with SHPOs/THPOs.* The agency official shall notify and consider the views of the SHPOs/THPOs on the exemption.

(4) *Consultation with Indian tribes and Native Hawaiian organizations.* If the exempted program or category of undertakings has the potential to affect historic properties on tribal lands or historic properties of religious and cultural significance to an Indian tribe or Native Hawaiian organization, the Council shall follow the requirements for the agency official set forth in paragraph (f) of this section.

(5) *Council review of proposed exemptions.* The Council shall review a request for an exemption that is supported by documentation describing the program or category for which the exemption is sought, demonstrating that the criteria of paragraph (c)(1) of this section have been met, describing the methods used to seek the views of the public, and summarizing any views submitted by the SHPO/THPOs, the public, and any others consulted. Unless it requests further information, the Council shall approve or reject the proposed exemption within 30 days of receipt, and thereafter notify the agency official and SHPO/THPOs of the decision. The decision shall be based on the consistency of the exemption with the purposes of the act, taking into consideration the magnitude of the exempted undertaking or program and the likelihood of impairment of historic properties in accordance with section 214 of the act.

(6) *Legal consequences.* Any undertaking that falls within an approved exempted program or category shall require no further review pursuant to subpart B of this part, unless the agency official or the Council determines that there are circumstances under which the normally excluded under-

taking should be reviewed under subpart B of this part.

(7) *Termination.* The Council may terminate an exemption at the request of the agency official or when the Council determines that the exemption no longer meets the criteria of paragraph (c)(1) of this section. The Council shall notify the agency official 30 days before termination becomes effective.

(8) *Notice.* The agency official shall publish notice of any approved exemption in the FEDERAL REGISTER.

(d) *Standard treatments.* (1) *Establishment.* The Council, on its own initiative or at the request of another party, may establish standard methods for the treatment of a category of historic properties, a category of undertakings, or a category of effects on historic properties to assist Federal agencies in satisfying the requirements of subpart B of this part. The Council shall publish notice of standard treatments in the FEDERAL REGISTER.

(2) *Public participation.* The Council shall arrange for public participation appropriate to the subject matter and the scope of the standard treatment and consistent with subpart A of this part. The Council shall consider the nature of the standard treatment and its likely effects on historic properties and the individuals, organizations and entities likely to be interested. Where an agency official has proposed a standard treatment, the Council may request the agency official to arrange for public involvement.

(3) *Consultation with SHPOs/THPOs.* The Council shall notify and consider the views of SHPOs/THPOs on the proposed standard treatment.

(4) *Consultation with Indian tribes and Native Hawaiian organizations.* If the proposed standard treatment has the potential to affect historic properties on tribal lands or historic properties of religious and cultural significance to an Indian tribe or Native Hawaiian organization, the Council shall follow the requirements for the agency official set forth in paragraph (f) of this section.

(5) *Termination.* The Council may terminate a standard treatment by publication of a notice in the FEDERAL REGISTER 30 days before the termination takes effect.

(e) *Program comments.* An agency official may request the Council to comment on a category of undertakings in lieu of conducting individual reviews under §§ 800.4 through 800.6. The Council may provide program comments at its own initiative.

(1) *Agency request.* The agency official shall identify the category of undertakings, specify the likely effects on historic properties, specify the steps the agency official will take to ensure that the effects are taken into account, identify the time period for which the comment is requested and summarize any views submitted by the public.

(2) *Public participation.* The agency official shall arrange for public participation appropriate to the subject matter and the scope of the category and in accordance with the standards in subpart A of this part. The agency official shall consider the nature of the undertakings and their likely effects on historic properties and the individuals, organizations and entities likely to be interested.

(3) *Consultation with SHPOs/THPOs.* The Council shall notify and consider the views of SHPOs/THPOs on the proposed program comment.

(4) *Consultation with Indian tribes and Native Hawaiian organizations.* If the program comment has the potential to affect historic properties on tribal lands or historic properties of religious and cultural significance to an Indian tribe or Native Hawaiian organization, the Council shall follow the requirements for the agency official set forth in paragraph (f) of this section.

(5) *Council action.* Unless the Council requests additional documentation, notifies the agency official that it will decline to comment, or obtains the consent of the agency official to extend the period for providing comment, the Council shall comment to the agency official within 45 days of the request.

(i) If the Council comments, the agency official shall take into account the comments of the Council in carrying out the undertakings within the category and publish notice in the FEDERAL REGISTER of the Council's comments and steps the agency will take to ensure that effects to historic properties are taken into account.

(ii) If the Council declines to comment, the agency official shall continue to comply with the requirements of §§ 800.3 through 800.6 for the individual undertakings.

(6) *Withdrawal of comment.* If the Council determines that the consideration of historic properties is not being carried out in a manner consistent with the program comment, the Council may withdraw the comment and the agency official shall comply with the requirements of §§ 800.3 through 800.6 for the individual undertakings.

(f) *Consultation with Indian tribes and Native Hawaiian organizations when developing program alternatives.* Whenever an agency official proposes a program alternative pursuant to paragraphs (a) through (e) of this section, the agency official shall ensure that development of the program alternative includes appropriate government-to-government consultation with affected Indian tribes and consultation with affected Native Hawaiian organizations.

(1) *Identifying affected Indian tribes and Native Hawaiian organizations.* If any undertaking covered by a proposed program alternative has the potential to affect historic properties on tribal lands, the agency official shall identify and consult with the Indian tribes having jurisdiction over such lands. If a proposed program alternative has the potential to affect historic properties of religious and cultural significance to an Indian tribe or a Native Hawaiian organization which are located off tribal lands, the agency official shall identify those Indian tribes and Native Hawaiian organizations that might attach religious and cultural significance to such properties and consult with them. When a proposed program alternative has nationwide applicability, the agency official shall identify an appropriate government to government consultation with Indian tribes and consult with Native Hawaiian organizations in accordance with existing Executive orders, Presidential memoranda, and applicable provisions of law.

(2) *Results of consultation.* The agency official shall provide summaries of the views, along with copies of any written comments, provided by affected Indian



## Advisory Council on Historic Preservation

## § 800.16

tribes and Native Hawaiian organizations to the Council as part of the documentation for the proposed program alternative. The agency official and the Council shall take those views into account in reaching a final decision on the proposed program alternative.

### § 800.15 Tribal, State, and local program alternatives. [Reserved]

### § 800.16 Definitions.

(a) *Act* means the National Historic Preservation Act of 1966, as amended, 16 U.S.C. 470–470w-6.

(b) *Agency* means agency as defined in 5 U.S.C. 551.

(c) *Approval of the expenditure of funds* means any final agency decision authorizing or permitting the expenditure of Federal funds or financial assistance on an undertaking, including any agency decision that may be subject to an administrative appeal.

(d) *Area of potential effects* means the geographic area or areas within which an undertaking may directly or indirectly cause alterations in the character or use of historic properties, if any such properties exist. The area of potential effects is influenced by the scale and nature of an undertaking and may be different for different kinds of effects caused by the undertaking.

(e) *Comment* means the findings and recommendations of the Council formally provided in writing to the head of a Federal agency under section 106.

(f) *Consultation* means the process of seeking, discussing, and considering the views of other participants, and, where feasible, seeking agreement with them regarding matters arising in the section 106 process. The Secretary's "Standards and Guidelines for Federal Agency Preservation Programs pursuant to the National Historic Preservation Act" provide further guidance on consultation.

(g) *Council* means the Advisory Council on Historic Preservation or a Council member or employee designated to act for the Council.

(h) *Day or days* means calendar days.

(i) *Effect* means alteration to the characteristics of a historic property qualifying it for inclusion in or eligibility for the National Register.

(j) *Foreclosure* means an action taken by an agency official that effectively precludes the Council from providing comments which the agency official can meaningfully consider prior to the approval of the undertaking.

(k) *Head of the agency* means the chief official of the Federal agency responsible for all aspects of the agency's actions. If a State, local, or tribal government has assumed or has been delegated responsibility for section 106 compliance, the head of that unit of government shall be considered the head of the agency.

(l)(1) *Historic property* means any prehistoric or historic district, site, building, structure, or object included in, or eligible for inclusion in, the National Register of Historic Places maintained by the Secretary of the Interior. This term includes artifacts, records, and remains that are related to and located within such properties. The term includes properties of traditional religious and cultural importance to an Indian tribe or Native Hawaiian organization and that meet the National Register criteria.

(2) The term *eligible for inclusion in the National Register* includes both properties formally determined as such in accordance with regulations of the Secretary of the Interior and all other properties that meet the National Register criteria.

(m) *Indian tribe* means an Indian tribe, band, nation, or other organized group or community, including a native village, regional corporation, or village corporation, as those terms are defined in section 3 of the Alaska Native Claims Settlement Act (43 U.S.C. 1602), which is recognized as eligible for the special programs and services provided by the United States to Indians because of their status as Indians.

(n) *Local government* means a city, county, parish, township, municipality, borough, or other general purpose political subdivision of a State.

(o) *Memorandum of agreement* means the document that records the terms and conditions agreed upon to resolve the adverse effects of an undertaking upon historic properties.

(p) *National Historic Landmark* means a historic property that the Secretary

of the Interior has designated a National Historic Landmark.

(q) *National Register* means the National Register of Historic Places maintained by the Secretary of the Interior.

(r) *National Register criteria* means the criteria established by the Secretary of the Interior for use in evaluating the eligibility of properties for the National Register (36 CFR part 60).

(s)(1) *Native Hawaiian organization* means any organization which serves and represents the interests of Native Hawaiians; has as a primary and stated purpose the provision of services to Native Hawaiians; and has demonstrated expertise in aspects of historic preservation that are significant to Native Hawaiians.

(2) *Native Hawaiian* means any individual who is a descendant of the aboriginal people who, prior to 1778, occupied and exercised sovereignty in the area that now constitutes the State of Hawaii.

(t) *Programmatic agreement* means a document that records the terms and conditions agreed upon to resolve the potential adverse effects of a Federal agency program, complex undertaking or other situations in accordance with § 800.14(b).

(u) *Secretary* means the Secretary of the Interior acting through the Director of the National Park Service except where otherwise specified.

(v) *State Historic Preservation Officer (SHPO)* means the official appointed or designated pursuant to section 101(b)(1) of the act to administer the State historic preservation program or a representative designated to act for the State historic preservation officer.

(w) *Tribal Historic Preservation Officer (THPO)* means the tribal official appointed by the tribe's chief governing authority or designated by a tribal ordinance or preservation program who has assumed the responsibilities of the SHPO for purposes of section 106 compliance on tribal lands in accordance with section 101(d)(2) of the act.

(x) *Tribal lands* means all lands within the exterior boundaries of any Indian reservation and all dependent Indian communities.

(y) *Undertaking* means a project, activity, or program funded in whole or

in part under the direct or indirect jurisdiction of a Federal agency, including those carried out by or on behalf of a Federal agency; those carried out with Federal financial assistance; those requiring a Federal permit, license or approval; and those subject to State or local regulation administered pursuant to a delegation or approval by a Federal agency.

#### APPENDIX A TO PART 800—CRITERIA FOR COUNCIL INVOLVEMENT IN REVIEWING INDIVIDUAL SECTION 106 CASES

(a) *Introduction.* This appendix sets forth the criteria that will be used by the Council to determine whether to enter an individual section 106 review that it normally would not be involved in.

(b) *General policy.* The Council may choose to exercise its authorities under the section 106 regulations to participate in an individual project pursuant to the following criteria. However, the Council will not always elect to participate even though one or more of the criteria may be met.

(c) *Specific criteria.* The Council is likely to enter the section 106 process at the steps specified in the regulations in this part when an undertaking:

(1) *Has substantial impacts on important historic properties.* This may include adverse effects on properties that possess a national level of significance or on properties that are of unusual or noteworthy importance or are a rare property type; or adverse effects to large numbers of historic properties, such as impacts to multiple properties within a historic district.

(2) *Presents important questions of policy or interpretation.* This may include questions about how the Council's regulations are being applied or interpreted, including possible foreclosure or anticipatory demolition situations; situations where the outcome will set a precedent affecting Council policies or program goals; or the development of programmatic agreements that alter the way the section 106 process is applied to a group or type of undertakings.

(3) *Has the potential for presenting procedural problems.* This may include cases with substantial public controversy that is related to historic preservation issues; with disputes among or about consulting parties which the Council's involvement could help resolve; that are involved or likely to be involved in litigation on the basis of section 106; or carried out by a Federal agency, in a State or locality, or on tribal lands where the Council has previously identified problems with section 106 compliance pursuant to § 800.9(d)(2).

(4) *Presents issues of concern to Indian tribes or Native Hawaiian organizations.* This may include cases where there have been concerns

raised about the identification of, evaluation of or assessment of effects on historic properties to which an Indian tribe or Native Hawaiian organization attaches religious and cultural significance; where an Indian tribe or Native Hawaiian organization has requested Council involvement to assist in the resolution of adverse effects; or where there are questions relating to policy, interpretation or precedent under section 106 or its relation to other authorities, such as the Native American Graves Protection and Repatriation Act.

**PART 801—HISTORIC PRESERVATION REQUIREMENTS OF THE URBAN DEVELOPMENT ACTION GRANT PROGRAM**

Sec.

- 801.1 Purpose and authorities.
- 801.2 Definitions.
- 801.3 Applicant responsibilities.
- 801.4 Council comments.
- 801.5 State Historic Preservation Officer responsibilities.
- 801.6 Coordination with requirements under the National Environmental Policy Act (42 U.S.C. 4321 *et seq.*).
- 801.7 Information requirements.
- 801.8 Public participation.

APPENDIX 1 TO PART 801—IDENTIFICATION OF PROPERTIES: GENERAL

APPENDIX 2 TO PART 801—SPECIAL PROCEDURES FOR IDENTIFICATION AND CONSIDERATION OF ARCHEOLOGICAL PROPERTIES IN AN URBAN CONTEXT

AUTHORITY: Pub. L. 89-665, 80 Stat. 915 (16 U.S.C. 470); Pub. L. 94-422, 90 Stat. 1320 (16 U.S.C. 470(i)); Pub. L. 96-399, 94 Stat. 1619 (42 U.S.C. 5320).

SOURCE: 46 FR 42428, Aug. 20, 1981, unless otherwise noted.

**§ 801.1 Purpose and authorities.**

(a) These regulations are required by section 110(c) of the Housing and Community Development Act of 1980 (HCDA) (42 U.S.C. 5320) and apply only to projects proposed to be funded by the Department of Housing and Urban Development (HUD) under the Urban Development Action Grant (UDAG) Program authorized by title I of the Housing and Community Development Act of 1974, as amended (42 U.S.C. 5301). These regulations establish an expedited process for obtaining the comments of the Council specifically for the UDAG program and, except as specifically provided, substitute for the Council's regulations for the "Protec-

tion of Historic and Cultural Properties" (36 CFR part 800).

(b) Section 110(c) of the HCDA of 1980 requires UDAG applicants to: (1) Identify all properties, if any, which are included in the National Register of Historic Places and which will be affected by the project for which the application is made; (2) identify all other properties, if any, which will be affected by such project and which, as determined by the applicant, may meet the Criteria established by the Secretary of the Interior for inclusion in the National Register (36 CFR 60.6); and (3) provide a description of the effect, as determined by the applicant, of the project on properties identified pursuant to (1) and (2). If the applicant determines that such properties are affected, the Act requires that the information developed by the applicant must be forwarded to the appropriate State Historic Preservation Officer (SHPO) for review and to the Secretary of the Interior for a determination as to whether the affected properties are eligible for inclusion in the National Register.

(c) Section 106 of the National Historic Preservation Act of 1966, as amended (16 U.S.C. 470), requires the head of any Federal agency with jurisdiction over a Federal, federally assisted or federally licensed undertaking that affects a property included in or eligible for inclusion in the National Register of Historic Places to take into account the effect of the undertaking on such property and afford the Council a reasonable opportunity to comment. Under the UDAG program, applicants assume the status of a Federal agency for purposes of complying with section 106.

**§ 801.2 Definitions.**

The terms defined in 36 CFR 800.2 shall be used in conjunction with this regulation. Furthermore, as used in these regulations:

(a) *Urban Development Action Grant (UDAG) Program* means the program of the Department of Housing and Urban Development (HUD) authorized by title I of the Housing and Community Development Act (HCDA) of 1977 (42 U.S.C. 5318) to assist revitalization efforts in distressed cities and urban counties

### § 801.3

### 36 CFR Ch. VIII (7-1-03 Edition)

which require increased public and private investment.

(b) *Applicant* means cities and urban counties or Pocket of Poverty Communities which meet the criteria at 24 CFR 570.453. Except as specifically provided below, applicants, rather than the Secretary of HUD, must comply with these regulations.

(c) *Project* means a commercial, industrial, and/or neighborhood project supported by the UDAG program of the Department of HUD, as defined in 24 CFR 570.451(g). A project includes the group of integrally related public and private activities described in the grant application which are to be carried out to meet the objectives of the action grant program and consists of all action grant funded activities together with all non-action grant funded activities. A project is an *undertaking* as defined in 36 CFR 800.2(c).

(d) *State Historic Preservation Officer Review Period* is a 45 day period provided to the appropriate State Historic Preservation Officer by section 110(c) of the Housing and Community Development Act (HCDA) of 1980 for comment on the formal submission by the applicant of data on properties listed in the National Register or which may meet the Criteria and which will be affected by the proposed UDAG project. This period does not include any period during which the applicant seeks information from the State Historic Preservation Officer to assist the applicant in identifying properties, determining whether a property meets the Criteria for listing in the National Register of Historic Places and determining whether such property is affected by the project.

(e) *Secretary of the Interior Determination Period* is a 45 day period provided by section 110(c) of the HCDA of 1980 for a determination as to whether the identified properties are eligible for inclusion in the National Register.

#### § 801.3 Applicant responsibilities.

As early as possible before the applicant makes a final decision concerning a project and in any event prior to taking any action that would foreclose alternatives or the Council's ability to comment, the applicant should take the following steps to comply with the

requirements of section 106 of the National Historic Preservation Act and section 110 of the HCDA of 1980.

In order to facilitate the commenting process the applicant should forward to the Council information on the proposed project at the earliest practicable time if it appears that National Register properties or properties which meet the Criteria for inclusion will be affected. This will allow the Council to assist the applicant in expeditiously meeting its historic preservation requirements and facilitate the development of the Council's comments.

(a) *Information required.* It is the primary responsibility of the applicant requesting Council comments to conduct the appropriate studies and to provide the information necessary for a review of the effect a proposed project may have on a National Register property or a property which meets the Criteria, as well as the information necessary for adequate consideration of modifications or alterations to the proposed project that could avoid, mitigate, or minimize any adverse effects. It is the responsibility of the applicant to provide the information specified in § 801.7, to make an informed and reasonable evaluation of whether a property meets the National Register Criteria (36 CFR 60.6) and to determine the effect of a proposed undertaking on a National Register property or property which meets the Criteria.

(b) *Identification of properties.* Section 110 of the HCDA of 1980 makes UDAG applicants responsible for the identification of National Register properties and properties which may meet the Criteria for listing in the National Register that may be affected by the project. An appendix to these regulations sets forth guidance to applicants in meeting their identification responsibilities but does not set a fixed or inflexible standard for such efforts. Meeting this responsibility requires the applicant to make an earnest effort to identify and evaluate potentially affected historic properties by:

(1) Consulting the National Register of Historic Places to determine whether the project's impact area includes such properties;

(2) Obtaining, prior to initiating the State Historic Preservation Officer Review Period, relevant information that the State Historic Preservation Officer may have available concerning historic properties, if any are known, in the project's impact area;

(3) Utilizing local plans, surveys, and inventories of historic properties prepared by the locality or a recognized State or local historic authority;

(4) Utilizing other sources of information or advice the applicant deems appropriate;

(5) Conducting an on-the-ground inspection of the project's impact area by qualified personnel to identify properties which may meet the Criteria for evaluation taking into consideration the views of the State Historic Preservation Officer as to the need for and methodology of such inspections;

(6) Applying the Department of the Interior Criteria for Evaluation (36 CFR 60.6) to properties within the project's impact area.

(c) *Evaluation of effect.* Applicants are required by section 110(a) of the HCDA of 1980 to include in their applications a description of the effect of a proposed UDAG project on any National Register property and or any property which may meet the Criteria.

(1) *Criteria of Effect and Adverse Effect.* The following criteria, similar to those set forth in 36 CFR 800.3, shall be used to determine whether a project has an effect or an adverse effect.

(i) *Criteria of effect.* The effect of a project on a National Register or eligible property is evaluated in the context of the historical, architectural, archeological, or cultural significance possessed by the property. A project shall be considered to have an effect whenever any condition of the project causes or may cause any change, beneficial or adverse, in the quality of the historical, architectural, archeological, or cultural characteristics that qualify the property to meet the Criteria of the National Register. An effect occurs when a project changes the integrity of location, design, setting, materials, workmanship, feeling or association of the property that contributes to its significance in accordance with the National Register Criteria. An effect may be direct or indirect. Direct effects are

caused by the project and occur at the same time and place. Indirect effects include those caused by the undertaking that are later in time or farther removed in distance, but are still reasonably foreseeable. Such effects involve development of the project site around historic properties so as to affect the access to, use of, or significance of those properties.

(ii) *Criteria of adverse effect.* Adverse effects on National Register properties or properties which meet the Criteria may occur under conditions which include but are not limited to:

(A) Destruction or alteration of all or part of a property;

(B) Isolation from or alteration of the property's surrounding environment;

(C) Introduction of visual, audible, or atmospheric elements that are out of character with the property or alter its setting;

(D) Neglect of a property resulting in its deterioration or destruction;

(iii) *Special considerations.* If rehabilitation is a project activity, such components of the project may be considered to have no adverse effect and need not be referred to the Council if they are undertaken in accordance with the Secretary of the Interior's Standards for Historic Preservation Projects (U.S. Department of the Interior, Heritage Conservation and Recreation Service, Washington, DC, 1979) and the State Historic Preservation Officer concurs in the proposed activity. Additionally, the following types of project components or elements will be considered to not normally adversely affect properties listed in the National Register or which meet the Criteria.

(A) Insulation (except for the use of granular or liquid injected foam insulation in exterior walls or other vertical surfaces);

(B) Caulking;

(C) Weatherstripping;

(D) Replacement of Heating, Ventilating and Air Conditioning (HVAC) equipment, provided that such equipment is not historic and that replacement equipment is screened from public view and that the State Historic Preservation Officer and the applicant agree the equipment will not affect those qualities of the property which

### § 801.3

### 36 CFR Ch. VIII (7-1-03 Edition)

qualify it to meet the 36 CFR 60.6 Criteria;

(E) In-kind refenestration (for example, replacement of deteriorated windows of a similar configuration, color and material);

(F) Lowering of ceilings, provided the ceilings will not be visible from outside of the building or from an interior public space and that the State Historic Preservation Officer and the applicant agree it will not affect a quality which qualified the building to meet the 36 CFR 60.6 Criteria;

(G) Replacement in-kind of substantially deteriorated material, provided that the State Historic Preservation Officer and the applicant agree;

(H) Installation of machinery, equipment, furnishings, fixtures, etc., in the interior of existing buildings, provided that the State Historic Preservation Officer and the applicant agree such installations will not affect a quality which qualified the building to meet the 36 CFR 60.6 Criteria.

(I) Site improvements such as sidewalk paving and landscaping, provided that the State Historic Preservation Officer and the applicant agree that the site improvement will not affect those qualities of the property which qualify it to meet the 36 CFR 60.6 Criteria.

(iv) *Special considerations for archeological sites.* Under certain conditions, alteration of land containing archeological resources in the project area may have no adverse effect on those resources. Procedures for determining whether such conditions exist were published by the Council in the FEDERAL REGISTER on November 26, 1980 (45 FR 78808), as part X of the "Executive Director's Procedures for Review of Proposals for Treatment of Archeological Properties." Because the identification of archeological sites in an urban context, and consideration of appropriate treatment methods, present special problems, further guidance is provided in Appendix 2.

(2) *Determinations of Effect.* Prior to submitting an application to HUD, the applicant shall apply the Criteria of Effect and Adverse Effect to all properties which are listed in the National Register or which may meet the Criteria in the area of the project's poten-

tial environmental impact. The determination of the Secretary of the Interior shall be final with respect to properties which are eligible for listing in the National Register. The Council will not comment on affected properties which are not either listed in or eligible for listing in the National Register. In order to facilitate the process, information to be requested from the State Historic Preservation Officer under § 801.3(b)(2) should include advice on applying the Criteria of Effect and Adverse Effect provided that this period shall not be included in the 45 day State Historic Preservation Officer Review Period. Special attention should be paid to indirect effects, such as changes in land use, traffic patterns, street activity, population density and growth rate. While some aspects of a project may have little potential to adversely affect the significant qualities of a historic property, other project components may meet the Criteria of Effect and Adverse Effect. If any aspect of the project results in an effect determination, further evaluation of the effect shall be undertaken in accordance with these regulations. The resulting determination regarding the effect shall be included in the application.

(i) *No effect.* If the applicant determines that the project will have no effect on any National Register property and/or property which meets the Criteria, the project requires no further review by the Council unless a timely objection is made by the Executive Director. An objection may be made by the Executive Director at any time during the UDAG application process prior to the expiration of the period for receiving objections to HUD's release of funds as specified in 24 CFR 58.31. The manner in which the Executive Director shall make an objection is set forth in § 801.4(a).

(ii) *Determinations of no adverse effect.* If the applicant finds there is an effect on the property but it is not adverse, the applicant after receiving the comments of the State Historic Preservation Officer during the State Historic Preservation Officer Review Period shall forward adequate documentation (see § 801.7(a)) of the Determination, including the written comments of the State Historic Preservation Officer, if

available, to the Executive Director for review in accordance with § 801.4.

(iii) *Adverse effect determination.* If the applicant finds the effect to be adverse or if the Executive Director objects to an applicant's no adverse effect determination pursuant to § 801.4(a), the applicant shall proceed with the consultation process in accordance with § 801.4(b).

**§ 801.4 Council comments.**

The following subsections specify how the Council will respond to an applicant's request for the Council's comments required to satisfy the applicant's responsibilities under section 106 of the Act and section 110 of the HCDA of 1980. When appropriate, an applicant may waive the Council time periods specified in these regulations.

(a) *Executive Director's Objection to No Effect Determination.* If the Executive Director has reason to question an applicant's determination of no effect, he shall notify the applicant and HUD. If the Executive Director does not object within 15 days of such notification, the project may proceed. If the Executive Director objects, he shall specify whether or not the project will have an adverse effect on National Register property and/or property which meets the Criteria. Normally, the Executive Director will object to a determination of no effect when the record does not support the applicant's determination (see § 801.7(a)). The applicant must then comply with the provisions of subsection (b) if the Executive Director determines that the project will have no adverse effect or subsection (c) if the Executive Director has determined that the project will have an adverse effect.

(b) *Response to Determinations of No Adverse Effect.* (1) Upon receipt of a Determination of No Adverse Effect from an applicant, the Executive Director will review the Determination and supporting documentation required by § 801.7(a). Failure to provide the required information at the time the applicant requests Council comments will delay the process. The Executive Director will respond to the applicant within 15 days after receipt of the information required in § 801.7(a). Unless the Executive Director objects to the Determina-

tion within 15 days after receipt, the applicant will be considered to have satisfied its responsibilities under section 106 of the Act and these regulations and no further Council review is required.

(2) If the Executive Director objects to a Determination of No Adverse Effect, the consultation process pursuant to § 801.4(c) shall be initiated.

(c) *Consultation process.* If any aspect of the project is found to have adverse effects on National Register property or property which has been determined by the applicant or the Secretary of the Interior to meet the Criteria, the applicant, the State Historic Preservation Officer and the Executive Director shall consult to consider feasible and prudent alternatives to the project that could avoid, mitigate, or minimize the adverse effect on the affected property.

(1) *Parties.* The applicant, the State Historic Preservation Officer and the Executive Director shall be the consulting parties. The Department of HUD, other representatives of national, State, or local units of government, other parties in interest, and public and private organizations, may be invited by the consulting parties to participate in the consultation process.

(2) *Timing.* The consulting parties shall have a total of 45 days from the receipt by the Executive Director of the information required in § 801.7(a) to agree upon feasible and prudent alternatives to avoid, mitigate, or minimize any adverse effects of the project. Failure of an applicant to provide the information required in § 801.7(b) will delay the beginning of the time period specified above.

(3) *Information requirements.* The applicant shall provide copies of the information required in § 801.7(b) to the consulting parties at the initiation of the consultation process and make it readily available for public inspection.

(4) *Public meeting.* An onsite inspection and a Public Information Meeting may be held in accordance with the provisions of 36 CFR 800.6(b). Public hearings or meetings conducted by the applicant in the preparation of the application may, as specified below, substitute for such Public Information

#### § 801.4

#### 36 CFR Ch. VIII (7-1-03 Edition)

Meetings. Upon request of the applicant, the Executive Director may find that such public meetings have been adequate to consider the effect of the project on National Register properties or properties which meet the Criteria, and no further Public Information Meeting is required.

(5) *Consideration of alternatives.* During the consultation period, the consulting parties shall, in accordance with the policies set forth in 36 CFR 800.6(b) (4) and (5), review the proposed project to determine whether there are prudent and feasible alternatives to avoid or satisfactorily mitigate adverse effect. If they agree on such alternatives, they shall execute a Memorandum of Agreement in accordance with § 801.4(c) specifying how the undertaking will proceed to avoid or mitigate the adverse effect.

(6) *Acceptance of adverse effect.* If the consulting parties determine that there are no feasible and prudent alternatives that could avoid or satisfactorily mitigate the adverse effects and agree that it is in the public interest to proceed with the proposed project they shall execute a Memorandum of Agreement in accordance with § 801.4(c) acknowledging this determination and specifying any recording, salvage, or other measures associated with acceptance of the adverse effects that shall be taken before the project proceeds.

(7) *Failure to agree.* Upon the failure of the consulting parties to agree upon the terms for a Memorandum of Agreement within the specified time period, or upon notice of a failure to agree by any consulting party to the Executive Director, the Executive Director within 15 days shall recommend to the Chairman whether the matter should be scheduled for consideration at a Council meeting. If the Executive Director recommends that the Council not consider the matter, he shall simultaneously notify all Council members and provide them copies of the preliminary case report and the recommendation to the Chairman. The applicant and the State Historic Preservation Officer shall be notified in writing of the Executive Director's recommendation.

(d) *Memorandum of Agreement—(1) Preparation of Memorandum of Agree-*

*ment.* It shall be the responsibility of the Executive Director to prepare each Memorandum of Agreement required under this part. As appropriate, other parties may be invited by the consulting parties to be signatories to the Agreement or otherwise indicate their concurrence with the Agreement. In order to facilitate the process, the applicant may provide the Executive Director a draft for a Memorandum of Agreement. At the applicant's option, such draft may be prepared at the time the applicant makes its determinations that properties listed in the National Register or which may meet the Criteria for listing in the National Register may be adversely affected. The applicant must provide the State Historic Preservation Officer an opportunity to concur in or comment on its draft Agreement.

(2) *Review of Memorandum of Agreement.* Upon receipt of an executed Memorandum of Agreement, the Chairman shall institute a 15 day review period. Unless the Chairman notifies the applicant that the matter has been placed on the agenda for consideration at a Council meeting, the Agreement shall become final when ratified by the Chairman or upon the expiration of the 15 day review period with no action taken. Copies will be provided to signatories. A copy of the Memorandum of Agreement should be included in any Environmental Assessment or Environmental Impact Statement prepared pursuant to the National Environmental Policy Act.

(3) *Effect of Memorandum of Agreement.* (i) Agreements duly executed in accordance with these regulations shall constitute the comments of the Council and shall evidence satisfaction of the applicant's responsibilities for the proposed project under section 106 of the Act and these regulations.

(ii) If the Council has commented on an application that is not approved by HUD and a subsequent UDAG application is made for the same project, the project need not be referred to the Council again unless there is a significant amendment to the project which would alter the effect of the project on previously considered properties or result in effects on additional National



## Advisory Council on Historic Preservation

## § 801.4

Register properties or properties which meet the Criteria.

(iii) Failure to carry out the terms of a Memorandum of Agreement requires that the applicant again request the Council's comments in accordance with these regulations. In such instances, until the Council issues its comments under these regulations the applicant shall not take or sanction any action or make any irreversible or irretrievable commitment that could result in an adverse effect with respect to National Register properties or properties which are eligible for inclusion in the National Register covered by the Agreement or that would foreclose the Council's consideration of modifications or alternatives to the proposed project that could avoid or mitigate the adverse effect.

(4) *Amendment of a Memorandum of Agreement.* Amendments to the Agreement may be made as specified in 36 CFR 800.6(c)(4).

(5) *Report on Memorandum of Agreement.* Within 90 days after carrying out the terms of the Agreement, the applicant shall report to all signatories on the actions taken.

(e) *Council Meetings.* Council meetings to consider a project will be conducted in accordance with the policies set forth in 36 CFR 800.6(d).

(1) *Response to recommendation concerning consideration at Council meeting.* Upon receipt of a recommendation from the Executive Director concerning consideration of a proposed project at a Council meeting, the Chairman shall determine whether or not the project will be considered. The Chairman shall make a decision within 15 days of receipt of the recommendation of the Executive Director. In reaching a decision the Chairman shall consider any comments from Council members. If three members of the Council object within the 15 day period to the Executive Director's recommendation, the project shall be scheduled for consideration at a Council or panel meeting. Unless the matter is scheduled for consideration by the Council the Chairman shall notify the applicant, the Department of HUD, the State Historic Preservation Officer and other parties known to be interested of the decision not to consider the mat-

ter. Such notice shall be evidence of satisfaction of the applicant's responsibilities for the proposed project under section 106 of the Act and these regulations.

(2) *Decision to consider the project.* When the Council will consider a proposed project at a meeting, the Chairman shall either designate five members as a panel to hear the matter on behalf of the full Council or schedule the matter for consideration by the full Council. In either case, the meeting shall take place within 30 days of the Chairman's decision to consider the project, unless the applicant agrees to a longer time.

(i) A panel shall consist of three non-Federal members, one as Chairman, and two Federal members. The Department of HUD may not be a member of such panel.

(ii) Prior to any panel or full Council consideration of a matter, the Chairman will notify the applicant and the State Historic Preservation Officer and other interested parties of the date on which the project will be considered. The Executive Director, the applicant, the Department of HUD, and the State Historic Preservation Officer shall prepare reports in accordance with § 801.7(b). Reports from the applicant and the State Historic Preservation Officer must be received by the Executive Director at least 7 days before any meeting.

(3) *Notice of Council meetings.* At least 7 days notice of all meetings held pursuant to this section shall be given by publication in the FEDERAL REGISTER. The Council shall provide a copy of the notice by mail to the applicant, the State Historic Preservation Officer, and the Department of Housing and Urban Development. The Council will inform the public of the meeting through appropriate local media.

(4) *Statements to the Council.* An agenda shall provide for oral statements from the Executive Director; the applicant; the Department of HUD; parties in interest; the Secretary of the Interior; the State Historic Preservation Officer; representatives of national, State, or local units of government; and interested public and private organizations and individuals. Parties wishing to make oral remarks should notify

the Executive Director at least two days in advance of the meeting. Parties wishing to have their written statements distributed to Council members prior to the meeting should send copies of the statements to the Executive Director at least 5 days in advance.

(5) *Comments of the Council.* The written comments of the Council will be issued within 7 days after a meeting. Comments by a panel shall be considered the comments of the full Council. Comments shall be made to the applicant requesting comment and to the Department of HUD. Immediately after the comments are made to the applicant and the Department of HUD, the comments of the Council will be forwarded to the President and the Congress as a special report under authority of section 202(b) of the Act and a notice of availability will be published in the FEDERAL REGISTER. The comments of the Council shall be made available to the State Historic Preservation Officer, other parties in interest, and the public upon receipt of the comments by the applicant. The applicant should include the comments of the Council in any final Environmental Impact Statement prepared pursuant to the National Environmental Policy Act.

(6) *Action in response to Council comments.* The comments of the Council shall be taken into account in reaching a final decision on the proposed project. When a final decision regarding the proposed project is reached by the applicant and the Department of HUD, they shall submit written reports to the Council describing the actions taken by them and other parties in response to the Council's comments and the impact that such actions will have on the affected National Register properties or properties eligible for inclusion in the National Register. Receipt of this report by the Chairman shall be evidence that the applicant has satisfied its responsibilities for the proposed project under section 106 of the Act and these regulations. The Council may issue a final report to the President and the Congress under authority of section 202(b) of the Act describing the actions taken in response to the Council's comments including rec-

ommendations for changes in Federal policy and programs, as appropriate.

(f) *Suspense of Action.* Until the Council issues its comments under these regulations and during the State Historic Preservation Officer Review Period and the determination period of the Secretary of the Interior, good faith consultation shall preclude the applicant from taking or sanctioning any action or making any irreversible or irretrievable commitment that could result in an adverse effect on a National Register property or property which may meet the Criteria or that would foreclose the consideration of modifications or alternatives to the proposed project that could avoid, mitigate, or minimize such adverse effects. In no case shall UDAG funds be used for physical activities on the project site until the Council comments have been completed. Normal planning and processing of applications short of actual commitment of funds to the project may proceed.

(g) *Lead Agency.* If the project proposed by the applicant involves one or more Federal agencies, they may agree on a single lead agency to meet the requirements of section 106 of the National Historic Preservation Act and section 110 of the Housing and Community Development Act of 1980 and notify the Executive Director. If the applicant is the designated lead agency, these regulations shall be followed. If a Federal agency is designated lead agency, the process in 36 CFR part 800 shall be used.

(h) *Compliance by a Federal Agency.* An applicant may make a finding that it proposes to accept a Federal agency's compliance with section 106 of the Act and 36 CFR 800 where its review of the Federal agency's findings indicate that:

(1) The project is identical with an undertaking reviewed by the Council under 36 CFR part 800; and

(2) The project and its impacts are included within the area of potential environmental impact described by the Federal agency;

The applicant shall notify the State Historic Preservation Officer and the Executive Director of its finding of compliance with section 106 of the Act and 36 CFR part 800 and provide a copy

## Advisory Council on Historic Preservation

## § 801.7

of the Federal agency's document where the finding occurs. Unless the Executive Director objects within 10 days of receipt of such notice the Council need not be afforded further opportunity for comment. If the Executive Director objects to the finding of the applicant, the applicant shall comply with § 801.4.

### § 801.5 State Historic Preservation Officer responsibilities.

(a) The State Historic Preservation Officer shall have standing to participate in the review process established by section 110(c) of the HCDA of 1980 whenever it concerns a project located within the State Historic Preservation Officer's jurisdiction by the following means: providing, within 30 days, information requested by an applicant under § 801.3(b); responding, within 45 days, to submittal of a determination by the applicant under section 110 of the HCDA of 1980 that National Register property or property which meets the Criteria may be affected by the proposed project; participating in a Memorandum of Agreement that the applicant or the Executive Director may prepare under this part; and participating in a panel or full Council meeting that may be held pursuant to these regulations. Pursuant to section 110(c) of the HCDA of 1980, the State Historic Preservation Officer has a maximum period of 45 days in which to formally comment on an applicant's determination that the project may affect a property that is listed in the National Register or which may meet the Criteria for listing in the National Register. This period does not include the time during which the applicant seeks information from the State Historic Preservation Officer for determining whether a property meets the Criteria for listing in the National Register and whether such property is affected by the project.

(b) The failure of a State Historic Preservation Officer to participate in any required steps of the process set forth in this part shall not prohibit the Executive Director and the applicant from concluding the section 106 process, including the execution of a Memorandum of Agreement.

### § 801.6 Coordination with requirements under the National Environmental Policy Act (42 U.S.C. 4321 et seq.).

The National Historic Preservation Act and the National Environmental Policy Act create separate and distinct responsibilities. The National Historic Preservation Act applies to those aspects of a project which may affect National Register properties and those which are eligible for listing in the National Register. The requirements for the National Environmental Policy Act apply to the effect that the project will have on the human environment. To the extent that the applicant finds it practicable to do so, the requirements of these two statutes should be integrated. Some projects, for reasons other than the effects on historic properties, may require an Environmental Impact Statement (EIS) subject to the time requirements for a draft and final EIS, in which case the applicant may choose to separately relate to the State Historic Preservation Officer, the Department of the Interior, and the Council for purposes of section 110(c) of the HCDA of 1980. In that event, information in the draft EIS should indicate that compliance with section 106 and these regulations is underway and the final EIS should reflect the results of this process. Applicants are directed to 36 CFR 800.9, which describes in detail the manner in which the requirements of these two acts should be integrated and applies to all UDAG applicants under these regulations.

In those instances in which an Environmental Impact Statement will be prepared for the project, the applicant should consider phasing compliance with these procedures and the preparation of the Statement.

### § 801.7 Information requirements.

(a) *Information To Be Retained by Applicants Determining No Effect.* (1) Recommended Documentation for a Determination of No Effect. Adequate documentation of a Determination of No Effect pursuant to § 801.3(c)(2)(i) should include the following:

(i) A general discussion and chronology of the proposed project;

## § 801.7

## 36 CFR Ch. VIII (7–1–03 Edition)

(ii) A description of the proposed project including, as appropriate, photographs, maps, drawings, and specifications;

(iii) A statement that no National Register property or property which meets the Criteria exist in the project area, or a brief statement explaining why the Criteria of Effect (See §801.3(c)) was found inapplicable;

(iv) Evidence of consultation with the State Historic Preservation Officer concerning the Determination of No Effect; and

(v) Evidence of efforts to inform the public concerning the Determination of No Effect.

(2) The information requirements set forth in this section are meant to serve as guidance for applicants in preparing No Effect Determinations. The information should be retained by the applicant, incorporated into any environmental reports or documents prepared concerning the project, and provided to the Executive Director only in the event of an objection to the applicant's determination.

(b) *Reports to the Council.* In order to adequately assess the impact of a proposed project on National Register and eligible properties, it is necessary for the Council to be provided certain information. For the purposes of developing Council comments on UDAG projects the following information is required. Generally, to the extent that relevant portions of a UDAG application meet the requirements set forth below it will be sufficient for the purposes of Council review and comment.

(1) *Documentation for Determination of No Adverse Effect.* Adequate documentation of a Determination of No Adverse Effect pursuant to §801.3(c)(1) should include the following:

(i) A general discussion and chronology of the proposed project;

(ii) A description of the proposed project including, as appropriate, photographs, maps, drawings and specifications;

(iii) A copy of the National Register form or a copy of the Determination of Eligibility documentation for each property that will be affected by the project including a description of each property's physical appearance and significance;

(iv) A brief statement explaining why each of the Criteria of Adverse Effect (See §801.3(c)(1)) was found inapplicable;

(v) Written views of the State Historic Preservation Officer concerning the Determination of No Adverse Effect, if available; and,

(vi) An estimate of the cost of the project including the amount of the UDAG grant and a description of any other Federal involvement.

(2) *Preliminary Case Reports.* Preliminary Case Reports should be submitted with a request for comments pursuant to §801.4(b) and should include the following information:

(i) A general discussion and chronology of the proposed project;

(ii) The status of the project in the HUD approval process;

(iii) The status of the project in the National Environmental Policy Act compliance process and the target date for completion of all the applicant's environmental responsibilities;

(iv) A description of the proposed project including as appropriate, photographs, maps, drawings and specifications;

(v) A copy of the National Register form or a copy of the Determination of Eligibility documentation for each property that will be affected by the project including a description of each property's physical appearance and significance;

(vi) A brief statement explaining why any of the Criteria of Adverse Effect (See §801.3(c)(1)(b)) apply;

(vii) Written views of the State Historic Preservation Officer concerning the effect on the property, if available;

(viii) The views of Federal agencies, State and local governments, and other groups or individuals when known as obtained through the OMB Circular A-95 process or the environmental review process, public hearings or other applicant processes;

(ix) A description and analysis of alternatives that would avoid the adverse effects;

(x) A description and analysis of alternatives that would mitigate the adverse effects; and,

(xi) An estimate of the cost of the project including the amount of the

UDAG grant and a description of any other Federal involvement.

(c) *Reports for Council Meetings.* Consideration of a proposed project by the full Council or a panel pursuant to §801.4(b) is based upon reports from the Executive Director, the State Historic Preservation Officer and Secretary of the Interior. Requirements for these reports are specified in 36 CFR 800.13(c). Additionally, reports from the applicant and the Department of HUD are required by these regulations. The requirements for these reports consist of the following:

(1) *Report of the Applicant.* The report from the applicant requesting comments shall include a copy of the relevant portions of the UDAG application; a general discussion and chronology of the proposed project; an account of the steps taken to comply with the National Environmental Policy Act (NEPA); any relevant supporting documentation in studies that the applicant has completed; an evaluation of the effect of the project upon the property or properties, with particular reference to the impact on the historical, architectural, archeological, and cultural values; steps taken or proposed by the applicant to avoid or mitigate adverse effects of the project; a thorough discussion of alternate courses of action; and an analysis comparing the advantages resulting from the project with the disadvantages resulting from the adverse effects on National Register or eligible properties.

(2) *Report of the Secretary of Housing and Urban Development.* The report from the Secretary shall include the status of the application in the UDAG approval process, past involvement of the Department with the applicant and the proposed project or land area for the proposed project, and information on how the applicant has met other requirements of the Department for the proposed project.

**§801.8 Public participation.**

(a) The Council encourages maximum public participation in the process established by these regulations. Particularly important, with respect to the UDAG program, is participation by the citizens of neighborhoods directly or indirectly affected by projects, and

by groups concerned with historic and cultural preservation.

(b) The applicant, in preparing and following its citizen participation plan called for by 24 CFR 570.456(c)(11)(i)(A), should ensure that adequate provision is made for participation by citizens and organizations having interests in historic preservation and in the historic and cultural values represented in affected neighborhoods. 24 CFR 570.431(c) sets forth criteria for citizen participation plans. These should be carefully considered with specific reference to ensuring that local concerns relevant to historic preservation are fully identified, and that citizens are provided with full and accurate information about each project and its effects on historic properties. The applicant should ensure that potentially concerned citizens and organizations are fully involved in the identification of properties which may meet the National Register Criteria, and that they are fully informed, in a timely manner, of determinations of No Effect, No Adverse Effect, and Adverse Effect, and of the progress of the consultation process. Applicants are referred to 36 CFR 800.15 for Council guidelines for public participation.

(c) The Council welcomes the views of the public, especially those groups which may be affected by the proposed project, during its evaluation of the applicant's determination of effect, and will solicit the participation of the public in Council and panel meetings held to consider projects.

APPENDIX 1 TO PART 801—IDENTIFICATION OF PROPERTIES: GENERAL

*A. Introduction*

Because of the high probability of locating properties which are listed in the National Register or which meet the Criteria for listing in many older city downtowns, this appendix is designed to serve as guidance for UDAG applicants in identifying such properties. This appendix sets forth guidance for applicants and does not set a fixed or inflexible standard for identification efforts.

*B. Role of the State Historic Preservation Officer*

In any effort to locate National Register properties or properties which meet the Criteria, the State Historic Preservation Officer is a key source of information and advice.

The State Historic Preservation Officer will be of vital assistance to the applicant. The State Historic Preservation Officer can provide information on known properties and on studies which have taken place in and around the project area. Early contact should be made with the State Historic Preservation Officer for recommendations about how to identify historic properties. For UDAG projects, identification of National Register properties and properties which meet the Criteria is the responsibility of the applicant. The extent of the identification effort should be made with the advice of the State Historic Preservation Officer. The State Historic Preservation Officer can be a knowledgeable source of information regarding cases wherein the need for a survey of historic properties is appropriate, recommended type and method of a survey and the boundaries of any such survey. Due consideration should be given to the nature of the project and its impacts, the likelihood of historic properties being affected and the state of existing knowledge regarding historic properties in the area of the project's potential environmental impact.

#### C. Levels of Identification

1. The area of the project's potential environmental impact consists of two distinct subareas: that which will be disturbed directly (generally the construction site and its immediate environs) and that which will experience indirect effects. Within the area of indirect impact, impacts will be induced as a result of carrying the project out. Historic and cultural properties subject to effect must be identified in both subareas, and the level of effort necessary in each may vary. The level of effort needed is also affected by the stage of planning and the quality of pre-existing information. Obviously, if the area of potential environmental impact has already been fully and intensively studied before project planning begins, there is no need to duplicate this effort. The State Historic Preservation Officer should be contacted for information on previous studies. If the area has not been previously intensively studied, identification efforts generally fall into three levels:

a. *Overview Study:* This level of study is normally conducted as a part of general planning and is useful at an early stage in project formulation. It is designed to obtain a general understanding of an area's historic and cultural properties in consultation with the State Historic Preservation Officer, by:

- (1) Assessing the extent to which the area has been previously subjected to study;
- (2) Locating properties previously recorded;
- (3) Assessing the probability that properties eligible for the National Register will be found if the area is closely inspected, and

- (4) Determining the need, if any, for further investigation.

An overview study includes study of pertinent records (local histories, building inventories, architectural reports, archeological survey reports, etc.), and usually some minor on-the-ground inspection.

b. *Identification Study:* An identification study attempts to specifically identify and record all properties in an area that may meet the criteria for listing in the National Register. In conducting the study, the applicant should seek the advice of the State Historic Preservation Officer regarding pertinent background data. A thorough on-the-ground inspection of the subject area by qualified personnel should be undertaken. For very large areas, or areas with uncertain boundaries, such a study may focus on representative sample areas, from which generalizations may be made about the whole.

c. *Definition and Evaluation Study:* If an overview and/or an identification study have indicated the presence or probable presence of properties that may meet the National Register Criteria but has not documented them sufficiently to allow a determination to be made about their eligibility, a definition and evaluation study is necessary. Such a study is directed at specific potentially eligible properties or at areas known or suspected to contain such properties. It includes an intensive on-the-ground inspection and related studies as necessary, conducted by qualified personnel, and provides sufficient information to apply the National Register's "Criteria for Evaluation" (36 CFR 60.6).

2. An overview study will normally be needed to provide basic information for planning in the area of potential environmental impact. Unless this study indicates clearly that no further identification efforts are needed (e.g., by demonstrating that the entire area has already been intensively inspected with negative results, or by demonstrating that no potentially significant buildings have ever been built there and there is virtually no potential for archeological resources), and identification study will probably be needed within the area of potential environmental impact. This study may show that there are no potentially eligible properties within the area, or may show that only a few such properties exist and document them sufficiently to permit a determination of eligibility to be made in accordance with 36 CFR part 60. Alternatively, the study may indicate that potentially eligible properties exist in the area, but may not document them to the standards of 36 CFR part 60. Should this occur, a definition and evaluation study is necessary for those properties falling within the project's area of direct effect and for those properties subject to indirect effects. If a property falls within the general area of indirect effect, but no indirect effects are actually anticipated on the

property in question, a definition and evaluation study will normally be superfluous.

APPENDIX 2 TO PART 801—SPECIAL PROCEDURES FOR IDENTIFICATION AND CONSIDERATION OF ARCHEOLOGICAL PROPERTIES IN AN URBAN CONTEXT

A. Archeological sites in urban contexts are often difficult to identify and evaluate in advance of construction because they are sealed beneath modern buildings and structures. Prehistoric and historic sites within cities may be important both to science and to an understanding of each city's history, however, and should be considered in project planning. Special methods can be used to ensure effective and efficient consideration and treatment of archeological sites in UDAG projects.

1. If it is not practical to physically determine the existence or nonexistence of archeological sites in the project area, the probability or improbability of their existence can be determined, in most cases, through study of:

- a. Information on the pre-urban natural environment, which would have had an effect on the location of prehistoric sites;
- b. Information from surrounding areas and general literature concerning the location of prehistoric sites;
- c. State and local historic property registers or inventories;
- d. Archeological survey reports;
- e. Historic maps, atlases, tax records, photographs, and other sources of information on the locations of earlier structures;
- f. Information on discoveries of prehistoric or historic material during previous construction, land levelling, or excavation, and
- g. Some minor on-the-ground inspection.

2. Should the study of sources such as those listed in section (1)(a) above reveal that the following conditions exist, it should be concluded that a significant likelihood exists that archeological sites which meet the National Register Criteria exist on the project site:

- a. Discoveries of prehistoric or historic material remains have been reliably reported on or immediately adjacent to the project site, and these are determined by the State Historic Preservation Officer or other archeological authority to meet the Criteria for the National Register because of their potential value for public interpretation or the study of significant scientific or historical research problems; or
- b. Historical or ethnographic data, or discoveries of material, indicate that a property of potential cultural value to the community or some segment of the community (e.g., a cemetery) lies or lay within the project site; or
- c. The pre-urbanization environment of the project site would have been conducive to

prehistoric occupation, or historic buildings or occupation sites are documented to have existed within the project site in earlier times, and such sites or buildings are determined by the State Historic Preservation Officer or other archeological authority to meet the Criteria of the National Register because of their potential value for public interpretation or the study of significant scientific or historical research questions, and

d. The recent history of the project site has not included extensive and intensive ground disturbance (grading, blasting, cellar digging, etc.) in the location, or extending to the depth at which the remains of significant sites, buildings, or other features would be expected.

B. Where review of sources of information such as those listed in section (1)(a) above reveals no significant likelihood that archeological resources which meet the National Register Criteria exist on the project site, no further review is required with respect to archeology provided the State Historic Preservation Officer concurs.

C. Where review of sources of information such as those listed in section (1)(a) above, reveals that archeological resources which meet the National Register Criteria are likely to exist on the project site, but these resources are so deeply buried that the project will not intrude upon them, or they are in a portion of the project site that will not be disturbed, a determination of "No Effect" is appropriate in accordance with §801.3(c)(2)(i).

D. Where review of sources of information such as those listed in section (1)(a) above, reveals that archeological resources which meet the Criteria exist or are likely to exist on the project site, and that the project is likely to disturb them, a determination of "No Adverse Effect" may be made in accordance with §801.3(c)(2)(ii) if:

1. The applicant and/or developer is committed to fund a professionally supervised and planned pre-construction testing program, and to modification of the project in consultation with the State Historic Preservation Officer to protect or incorporate within the project the archeological resources discovered with a minimum of damage to them, or if:

2. The applicant and/or developer is committed to fund a professionally supervised and planned archeological salvage program, coordinated with site clearing and construction, following the standards of the Secretary of the Interior issued pursuant to the Archeological and Historic Preservation Act (16 U.S.C. 469) and the applicant finds that this program negates the adverse effect, in accordance with the standards set forth in section X of the Council's "Supplementary Guidance for Review of Proposals for Treatment of Archeological Properties" (45 FR 78808).

E. When archeological sites included in the National Register or which meet the Criteria are found to exist on the project site or in the area of the project's environmental impact, and where the project is likely to disturb such resources, and where the adverse effect of such disturbance cannot be negated by archeological salvage, a determination of "Adverse Effect" is appropriate in accordance with § 801.3(a)(2)(iii).

## PART 805—PROCEDURES FOR IMPLEMENTATION OF NATIONAL ENVIRONMENTAL POLICY ACT

### Sec.

- 805.1 Background.
- 805.2 Purpose.
- 805.3 Applicability.
- 805.4 Ensuring environmental documents are actually considered in Council decisionmaking.
- 805.5 Typical classes of action.
- 805.6 Interagency cooperation.
- 805.7 Environmental information.

AUTHORITY: Pub. L. 89-665, 80 Stat. 915 (16 U.S.C. 470), as amended, 84 Stat. 204 (1970), 87 Stat. 139 (1973), 90 Stat. 1320 (1976), 92 Stat. 3467 (1978); E.O. 11593, 3 CFR 1971 Comp., p. 154; President's Memorandum on Environmental Quality and Water Resources Management, July 12, 1978.

SOURCE: 45 FR 4353, Jan. 22, 1980, unless otherwise noted.

### § 805.1 Background.

(a) The National Environmental Policy Act (NEPA) of 1969 (42 U.S.C. 4321 *et seq.*) establishes national policies and goals for the protection of the environment. Section 102(2) of NEPA contains certain procedural requirements directed toward the attainment of such goals. In particular, all Federal agencies are required to give appropriate consideration to the environmental effects of their proposed actions in their decisionmaking and to prepare detailed environmental statements on recommendations or reports on proposals for legislation and other major Federal actions significantly affecting the quality of the human environment.

(b) Executive Order 11991 of May 24, 1977, directed the Council on Environmental Quality (CEQ) to issue regulations to implement the procedural provisions of NEPA. Accordingly, CEQ issued final NEPA regulations (40 CFR parts 1500-1508) on November 29, 1978, which are binding on all Federal agen-

cies as of July 30, 1979. These regulations provide that each Federal agency shall as necessary adopt implementing procedures to supplement the regulations. Section 1507.3(b) of the NEPA regulations identifies those sections of the regulations which must be addressed in agency procedures.

### § 805.2 Purpose.

The purpose of this part is to establish Council procedures that supplement the NEPA regulations and provide for the implementation of those provisions identified in § 1507.3(b) of the regulations (40 CFR 1507.3(b)).

### § 805.3 Applicability.

(a) These procedures apply to actions of the full Council and the Council staff acting on behalf of the full Council.

(b) The following actions are covered by these procedures:

- (1) Recommendations for legislation.
- (2) Regulations implementing section 106 of the National Historic Preservation Act (NHPA).
- (3) Procedures implementing other authorities.
- (4) Policy recommendations that do not require implementation by another Federal agency.

(c) In accordance with § 1508.4 of the NEPA regulations (40 CFR 1508.4), Council comments on Federal, federally assisted and federally licensed undertakings provided pursuant to section 106 of the NHPA and 36 CFR part 800 are categorically excluded from these procedures. This exclusion is justified because Federal agencies seeking the Council's comments under section 106 have the responsibility for complying with NEPA on the action they propose. The Council's role is advisory and its comments are to be considered in the agency decisionmaking process. Coordination between the section 106 and the NEPA processes is set forth in 36 CFR 800.9.

### § 805.4 Ensuring environmental documents are actually considered in Council decisionmaking.

(a) Section 1505.1 of the NEPA regulations (40 CFR 1505.1) contains requirements to ensure adequate consideration of environmental documents in



agency decisionmaking. To implement these requirements the Council shall:

- (1) Consider all relevant environmental documents in evaluating proposals for action;
- (2) Ensure that all relevant environmental documents, comments, and responses accompany the proposal through internal Council review processes;
- (3) Consider only those alternatives encompassed by the range of alternatives discussed in the relevant environmental documents when evaluating proposals for the Council action; and,

(4) Where an environmental impact statement (EIS) has been prepared consider the specific alternative analyzed in the EIS when evaluating the proposal which is the subject of the EIS.

(b) For each of the Council's principal activities covered by NEPA, the following chart identifies the point at which the NEPA process begins, the point at which it ends, and the key officials required to consider environmental documents in their decision-making.

Activity	Start of NEPA process	Completion of NEPA process	Key officials required to consider environmental documents
Recommendations for legislation.	During staff formulation of proposal.	Prior to submission to Congress or OMB.	Executive Director and full Council, as appropriate.
Regulations and procedures ...	Prior to publication of draft regulations in FEDERAL REGISTER.	Prior to publication of final regulations in FEDERAL REGISTER.	Executive Director and full Council as appropriate.
Policy recommendations .....	During staff formulation of proposal.	Prior to adoption by full Council or Executive Director.	Executive Director and full Council, as appropriate.

**§ 805.5 Typical classes of action.**

(a) Section 1507.3(c)(2) (40 CFR 1507.3(c)(2)) in conjunction with §1508.4 requires agencies to establish three typical classes of action for similar treatment under NEPA: actions normally requiring EIS; actions normally requiring assessments but not necessarily EISs; and actions normally not requiring assessments or EISs. Each of the covered categories of Council actions generally falls within the second category, normally requiring an assessment but not necessarily an EIS.

(b) The Council shall independently determine whether an EIS or an environmental assessment is required where:

- (1) A proposal for Council action is not covered by one of the typical classes of action above; or
- (2) For actions which are covered, the presence of extraordinary circumstances indicates that some other level of environmental review may be appropriate.

**§ 805.6 Interagency cooperation.**

The Council shall consult with appropriate Federal and non-Federal agencies and with interested private persons and organizations when it is con-

sidering actions involving such parties and requiring environmental assessments. Where other Federal agencies are involved in the proposed action, the Council shall cooperate in the required environmental assessment and the preparation of necessary environmental documents. Where appropriate as determined by the nature and extent of Council involvement in the proposed action, the Council shall assume the status of lead agency.

**§ 805.7 Environmental information.**

Interested persons may contact the Executive Director for information regarding the Council's compliance with NEPA.

**PART 810—FREEDOM OF INFORMATION ACT REGULATIONS**

- Sec.
- 810.1 Purpose and scope.
- 810.2 Procedure for requesting information.
- 810.3 Action on requests.
- 810.4 Appeals.
- 810.5 Fees.
- 810.6 Exemptions.

AUTHORITY: Pub. L. 89-665, 80 Stat. 915 (16 U.S.C. 470) as amended by Pub. L. 91-243, Pub. L. 93-54, Pub. L. 94-422, Pub. L. 94-458, Pub. L. 96-199, Pub. L. 96-244, Pub. L. 96-515.

## § 810.1

SOURCE: 46 FR 45334, Sept. 11, 1981, unless otherwise noted.

### § 810.1 Purpose and scope.

This subpart contains the regulations of the Advisory Council on Historic Preservation implementing the Freedom of Information Act (5 U.S.C. 552). Procedures for obtaining the records covered by the Act are established in these regulations. Persons seeking information or records of the Council are encouraged to consult first with the staff of the Council before filing a formal request under the Act pursuant to these regulations. The informal exchange of information is encouraged wherever possible.

### § 810.2 Procedure for requesting information.

(a) Requests for information or records not available through informal channels shall be directed to the Administrative Officer, Advisory Council on Historic Preservation, 1522 K Street NW., Washington, DC 20005. All such requests should be clearly marked "FREEDOM OF INFORMATION REQUEST" in order to ensure timely processing. Requests that are not so marked will be honored, but will be deemed not to have been received by the Council, for purposes of computing the response time, until the date on which they are identified by a member of the Council staff as being a request pursuant to the Freedom of Information Act.

(b) Requests should describe the records sought in sufficient detail to allow Council staff to locate them with a reasonable amount of effort. Thus, where possible, specific information, including dates, geographic location of cases, and parties involved, should be supplied.

(c) A request for all records falling within a reasonably specific category shall be regarded as conforming to the statutory requirement that records be reasonably described if the records can be identified by any process that is not unreasonably burdensome or disruptive of Council operations.

(d) If a request is denied on the ground that it does not reasonably describe the records sought, the denial shall specify the reasons why the re-

## 36 CFR Ch. VIII (7-1-03 Edition)

quest was denied and shall extend to the requester an opportunity to confer with Council staff in order to reformulate the request in sufficient detail to allow the records to be produced.

### § 810.3 Action on requests.

(a) Once a requested record has been identified, the Administrative Officer shall notify the requester of a date and location where the records may be examined or of the fact that copies are available. The notification shall also advise the requester of any applicable fees under § 810.5.

(b) A reply denying a request shall be in writing, signed by the Administrative Officer and shall include:

(1) Reference to the specific exemption under the Act which authorizes the denial of the record, a brief explanation of how the exemption applies to the record requested, and a brief statement of why a discretionary release is not appropriate; and,

(2) A statement that the denial may be appealed under § 810.4 within 30 days by writing to the Executive Director, Advisory Council on Historic Preservation, 1522 K Street NW., Washington, DC 20005.

(c) The requirements of § 810.3 (b)(1) and (2) do not apply to requests denied on the ground that they are not described with reasonable specificity and consequently cannot be identified.

(d) Within 10 working days from receipt of a request, the Administrative Officer shall determine whether to grant or deny the request and shall promptly notify the requester of the decision. In certain unusual circumstances specified below, the time for determinations on requests may be extended up to a total of 10 additional working days. The requester shall be notified in writing of any extension and of the reason for it, as well as of the data on which a determination will be made. Unusual circumstances include:

(1) The need to search for and collect records from field offices or other establishments that are separate from the Washington office of the Council;

(2) The need to search for, collect, and examine a voluminous amount of material which is sought in a request; or,

## Advisory Council on Historic Preservation

## § 810.6

(3) The need for consultation with another agency having substantial interest in the subject matter of the request.

If no determination has been made by the end of the 10-day period or the end of the last extension, the requester may deem his request denied and may exercise a right of appeal in accordance with § 810.4.

### § 810.4 Appeals.

(a) When a request has been denied, the requester may, within 30 days of receipt of the denial, appeal the denial to the Executive Director of the Council. Appeals to the Executive Director shall be in writing, shall be addressed to the Executive Director, Advisory Council on Historic Preservation, 1522 K Street NW., Washington, DC 20005, and shall be clearly marked "FREEDOM OF INFORMATION APPEAL." Requests that are not so marked will be honored, but will be deemed not to have been received by the Council, for purposes of computing the response time, until the date on which they are identified by a member of the Council staff as being an appeal pursuant to the Freedom of Information Act.

(b) The appeal will be acted on within 20 working days of receipt. A written decision shall be issued. Where the decision upholds an initial denial of information, the decision shall include a reference to the specific exemption in the Freedom of Information Act which authorizes withholding the information, a brief explanation of how the exemption applies to the record withheld, and a brief statement of why a discretionary release is not appropriate. The decision shall also inform the requester of the right to seek judicial review in the U.S. District Court where the requester resides or has his principal place of business, or in which the agency records are situated, or in the District of Columbia.

(c) If no decision has been issued within 20 working days, the requester is deemed to have exhausted his administrative remedies.

### § 810.5 Fees.

(a) Fees shall be charged according to the schedules contained in paragraph (b) of this section unless it is deter-

mined that the requested information will be of primary benefit to the general public rather than to the requester. In that case, fees may be waived. Fees shall not be charged where they would amount to less than \$3.00.

(b) The following charges shall be assessed:

(1) Copies of documents—\$0.10 per page.

(2) Clerical searches—\$1.00 for each one quarter hour in excess of the first quarter hour spent by clerical personnel in searching for requested records.

(3) Professional searches—\$2.00 for each one quarter hour in excess of the first quarter hour spent by professional or managerial personnel in determining which records are covered by a request or other tasks that cannot be performed by clerical personnel.

(c) Where it is anticipated that fees may amount to more than \$25.00, the requester shall be advised of the anticipated amount of the fee and his consent obtained before the request is processed. The time limits for processing the request under § 810.3 shall not begin to run until the requester's written agreement to pay the fees has been received. In the discretion of the Administrative Officer, advance payment of fees may be required before requested records are made available.

(d) Payment should be made by check or money order payable to the Advisory Council on Historic Preservation.

### § 810.6 Exemptions.

(a) The Freedom of Information Act exempts from disclosure nine categories of records which are described in 5 U.S.C. 552(b).

(b) When a request encompasses records which would be of concern to or which have been created primarily by another Federal agency, the record will be made available by the Council only if the document was created primarily to meet the requirements of the Council's regulations implementing section 106 of the National Historic Preservation Act or other provisions of law administered primarily by the Council. If

the record consists primarily of materials submitted by State or local governments, private individuals, organizations, or corporations, to another Federal agency in fulfillment of requirements for receiving assistance, permits, licenses, or approvals from the agency, the Council may refer the request to that agency. The requester shall be notified in writing of the referral.

### PART 811—EMPLOYEE RESPONSIBILITIES AND CONDUCT

AUTHORITY: 5 U.S.C. 7301 and 16 U.S.C.470, as amended.

SOURCE: 63 FR 54355, Oct. 9, 1998, unless otherwise noted.

#### § 811.1 Cross-references to employees' ethical conduct standards, financial disclosure and financial interests regulations and other conduct rules.

Employees of the Advisory Council on Historic Preservation are subject to the executive branch-wide standards of ethical conduct, financial disclosure and financial interests regulations at 5 CFR Parts 2634, 2635 and 2640, as well as the executive branch-wide employee responsibilities and conduct regulations at 5 CFR Part 735.

### PART 812—ENFORCEMENT OF NONDISCRIMINATION ON THE BASIS OF HANDICAP IN PROGRAMS OR ACTIVITIES CONDUCTED BY THE ADVISORY COUNCIL ON HISTORIC PRESERVATION

Sec.

- 812.101 Purpose.
- 812.102 Application.
- 812.103 Definitions.
- 812.104-812.109 [Reserved]
- 812.110 Self-evaluation.
- 812.111 Notice.
- 812.112-812.129 [Reserved]
- 812.130 General prohibitions against discrimination.
- 812.131-812.139 [Reserved]
- 812.140 Employment.
- 812.141-812.148 [Reserved]
- 812.149 Program accessibility: Discrimination prohibited.
- 812.150 Program accessibility: Existing facilities.

812.151 Program accessibility: New construction and alterations.

812.152-812.159 [Reserved]

812.160 Communications.

812.161-812.169 [Reserved]

812.170 Compliance procedures.

812.171-812.999 [Reserved]

AUTHORITY: 29 U.S.C. 794.

SOURCE: 51 FR 22896, June 23, 1986, unless otherwise noted.

#### § 812.101 Purpose.

This part effectuates section 119 of the Rehabilitation, Comprehensive Services, and Developmental Disabilities Amendments of 1978, which amended section 504 of the Rehabilitation Act of 1973 to prohibit discrimination on the basis of handicap in programs or activities conducted by Executive agencies or the United States Postal Service.

#### § 812.102 Application.

This part applies to all programs or activities conducted by the agency.

#### § 812.103 Definitions.

For purposes of this part, the term—  
*Assistant Attorney General* means the Assistant Attorney General, Civil Rights Division, United States Department of Justice.

*Auxiliary aids* means services or devices that enable persons with impaired sensory, manual, or speaking skills to have an equal opportunity to participate in, and enjoy the benefits of, programs or activities conducted by the agency. For example, auxiliary aids useful for persons with impaired vision include readers, brailled materials, audio recordings, telecommunications devices and other similar services and devices. Auxiliary aids useful for persons with impaired hearing include telephone handset amplifiers, telephones compatible with hearing aids, telecommunication devices for deaf persons (TDD's), interpreters, notetakers, written materials, and other similar services and devices.

*Complete complaint* means a written statement that contains the complainant's name and address and describes the agency's alleged discriminatory action in sufficient detail to inform the agency of the nature and date of the alleged violation of section 504. It shall

be signed by the complainant or by someone authorized to do so on his or her behalf. Complaints filed on behalf of classes or third parties shall describe or identify (by name, if possible) the alleged victims of discrimination.

*Facility* means all or any portion of buildings, structures, equipment, roads, walks, parking lots, rolling stock or other conveyances, or other real or personal property.

*Handicapped person* means any person who has a physical or mental impairment that substantially limits one or more major life activities, has a record of such an impairment, or is regarded as having such an impairment.

As used in this definition, the phrase:

(1) *Physical or mental impairment* includes—

(i) Any physiological disorder or condition, cosmetic disfigurement, or anatomical loss affecting one or more of the following body systems: Neurological; musculoskeletal; special sense organs; respiratory, including speech organs; cardiovascular; reproductive; digestive; genitourinary; hemic and lymphatic; skin; and endocrine; or

(ii) Any mental or psychological disorder, such as mental retardation, organic brain syndrome, emotional or mental illness, and specific learning disabilities. The term *physical or mental impairment* includes, but is not limited to, such diseases and conditions as orthopedic, visual, speech, and hearing impairments, cerebral palsy, epilepsy, muscular dystrophy, multiple sclerosis, cancer, heart disease, diabetes, mental retardation, emotional illness, and drug addiction and alcoholism.

(2) *Major life activities* includes functions such as caring for one's self, performing manual tasks, walking, seeing, hearing, speaking, breathing, learning, and working.

(3) *Has a record of such an impairment* means has a history of, or has been misclassified as having, a mental or physical impairment that substantially limits one or more major life activities.

(4) *Is regarded as having an impairment* means—

(i) Has a physical or mental impairment that does not substantially limit major life activities but is treated by

the agency as constituting such a limitation;

(ii) Has a physical or mental impairment that substantially limits major life activities only as a result of the attitudes of others toward such impairment; or

(iii) Has none of the impairments defined in paragraph (1) of this definition but is treated by the agency as having such an impairment.

*Historic preservation programs* means programs conducted by the agency that have preservation of historic properties as a primary purpose.

*Historic properties* means those properties that are listed or eligible for listing in the National Register of Historic Places or properties designated as historic under a statute of the appropriate State or local government body.

*Qualified handicapped person* means—

(1) With respect to preschool, elementary, or secondary education services provided by the agency, a handicapped person who is a member of a class of persons otherwise entitled by statute, regulation, or agency policy to receive education services from the agency.

(2) With respect to any other agency program or activity under which a person is required to perform services or to achieve a level of accomplishment, a handicapped person who meets the essential eligibility requirements and who can achieve the purpose of the program or activity without modifications in the program or activity that the agency can demonstrate would result in a fundamental alteration in its nature;

(3) With respect to any other program or activity, a handicapped person who meets the essential eligibility requirements for participation in, or receipt of benefits from, that program or activity; and

(4) *Qualified handicapped person* is defined for purposes of employment in 29 CFR 1613.702(f), which is made applicable to this part by § 812.140.

*Section 504* means section 504 of the Rehabilitation Act of 1973 (Pub. L. 93-112, 87 Stat. 394 (29 U.S.C. 794)), as amended by the Rehabilitation Act Amendments of 1974 (Pub. L. 93-516, 88 Stat. 1617), and the Rehabilitation, Comprehensive Services, and Developmental Disabilities Amendments of

**§§ 812.104–812.109**

1978 (Pub. L. 95–602, 92 Stat. 2955). As used in this part, section 504 applies only to programs or activities conducted by Executive agencies and not to federally assisted programs.

*Substantial impairment* means a significant loss of the integrity of finished materials, design quality, or special character resulting from a permanent alteration.

**§§ 812.104–812.109 [Reserved]**

**§ 812.110 Self-evaluation.**

(a) The agency shall, by August 24, 1987, evaluate its current policies and practices, and the effects thereof, that do not or may not meet the requirements of this part, and, to the extent modification of any such policies and practices is required, the agency shall proceed to make the necessary modifications.

(b) The agency shall provide an opportunity to interested persons, including handicapped persons or organizations representing handicapped persons, to participate in the self-evaluation process by submitting comments (both oral and written).

(c) The agency shall, until three years following the completion of the self-evaluation, maintain on file and make available for public inspection:

(1) A description of areas examined and any problems identified, and

(2) A description of any modifications made.

**§ 812.111 Notice.**

The agency shall make available to employees, applicants, participants, beneficiaries, and other interested persons such information regarding the provisions of this part and its applicability to the programs or activities conducted by the agency, and make such information available to them in such manner as the head of the agency finds necessary to apprise such persons of the protections against discrimination assured them by section 504 and this regulation.

**36 CFR Ch. VIII (7–1–03 Edition)**

**§§ 812.112–812.129 [Reserved]**

**§ 812.130 General prohibitions against discrimination.**

(a) No qualified handicapped person shall, on the basis of handicap, be excluded from participation in, be denied the benefits of, or otherwise be subjected to discrimination under any program or activity conducted by the agency.

(b)(1) The agency, in providing any aid, benefit, or service, may not, directly or through contractual, licensing, or other arrangements, on the basis of handicap—

(i) Deny a qualified handicapped person the opportunity to participate in or benefit from the aid, benefit, or service;

(ii) Afford a qualified handicapped person an opportunity to participate in or benefit from the aid, benefit, or service that is not equal to that afforded others;

(iii) Provide a qualified handicapped person with an aid, benefit, or service that is not as effective in affording equal opportunity to obtain the same result, to gain the same benefit, or to reach the same level of achievement as that provided to others;

(iv) Provide different or separate aid, benefits, or services to handicapped persons or to any class of handicapped persons than is provided to others unless such action is necessary to provide qualified handicapped persons with aid, benefits, or services that are as effective as those provided to others;

(v) Deny a qualified handicapped person the opportunity to participate as a member of planning or advisory boards; or

(vi) Otherwise limit a qualified handicapped person in the enjoyment of any right, privilege, advantage, or opportunity enjoyed by others receiving the aid, benefit, or service.

(2) The agency may not deny a qualified handicapped person the opportunity to participate in programs or activities that are not separate or different, despite the existence of permissibly separate or different programs or activities.

(3) The agency may not, directly or through contractual or other arrangements, utilize criteria or methods of administration the purpose or effect of which would—

(i) Subject qualified handicapped persons to discrimination on the basis of handicap; or

(ii) Defeat or substantially impair accomplishment of the objectives of a program or activity with respect to handicapped persons.

(4) The agency may not, in determining the site or location of a facility, make selections the purpose or effect of which would—

(i) Exclude handicapped persons from, deny them the benefits of, or otherwise subject them to discrimination under any program or activity conducted by the agency; or

(ii) Defeat or substantially impair the accomplishment of the objectives of a program or activity with respect to handicapped persons.

(5) The agency, in the selection of procurement contractors, may not use criteria that subject qualified handicapped persons to discrimination on the basis of handicap.

(6) The agency may not administer a licensing or certification program in a manner that subjects qualified handicapped persons to discrimination on the basis of handicap, nor may the agency establish requirements for the programs or activities of licensees or certified entities that subject qualified handicapped persons to discrimination on the basis of handicap. However, the programs or activities of entities that are licensed or certified by the agency are not, themselves, covered by this part.

(c) The exclusion of nonhandicapped persons from the benefits of a program limited by Federal statute or Executive order to handicapped persons or the exclusion of a specific class of handicapped persons from a program limited by Federal statute or Executive order to a different class of handicapped persons is not prohibited by this part.

(d) The agency shall administer programs and activities in the most integrated setting appropriate to the needs of qualified handicapped persons.

§§ 812.131–812.139 [Reserved]

**§ 812.140 Employment.**

No qualified handicapped person shall, on the basis of handicap, be subjected to discrimination in employment under any program or activity conducted by the agency. The definitions, requirements, and procedures of section 501 of the Rehabilitation Act of 1973 (29 U.S.C. 791), as established by the Equal Employment Opportunity Commission in 29 CFR part 1613, shall apply to employment in federally conducted programs or activities.

§§ 812.141–812.148 [Reserved]

**§ 812.149 Program accessibility: Discrimination prohibited.**

Except as otherwise provided in § 812.150, no qualified handicapped person shall, because the agency's facilities are inaccessible to or unusable by handicapped persons, be denied the benefits of, be excluded from participation in, or otherwise be subjected to discrimination under any program or activity conducted by the agency.

**§ 812.150 Program accessibility: Existing facilities.**

(a) *General.* The agency shall operate each program or activity so that the program or activity, when viewed in its entirety, is readily accessible to and usable by handicapped persons. This paragraph does not—

(1) Necessarily require the agency to make each of its existing facilities accessible to and usable by handicapped persons;

(2) In the case of historic preservation programs, require the agency to take any action that would result in a substantial impairment of significant historic features of an historic property; or

(3) Require the agency to take any action that it can demonstrate would result in a fundamental alteration in the nature of a program or activity or in undue financial and administrative burdens. In those circumstances where agency personnel believe that the proposed action would fundamentally alter the program or activity or would result in undue financial and administrative burdens, the agency has the

## §812.151

burden of proving that compliance with §812.150(a) would result in such alteration or burdens. The decision that compliance would result in such alteration or burdens must be made by the agency head or his or her designee after considering all agency resources available for use in the funding and operation of the conducted program or activity, and must be accompanied by a written statement of the reasons for reaching that conclusion. If an action would result in such an alteration or such burdens, the agency shall take any other action that would not result in such an alteration or such burdens but would nevertheless ensure that handicapped persons receive the benefits and services of the program or activity.

(b) *Methods*—(1) *General*. The agency may comply with the requirements of this section through such means as redesign of equipment, reassignment of services to accessible buildings, assignment of aides to beneficiaries, home visits, delivery of services at alternate accessible sites, alteration of existing facilities and construction of new facilities, use of accessible rolling stock, or any other methods that result in making its programs or activities readily accessible to and usable by handicapped persons. The agency is not required to make structural changes in existing facilities where other methods are effective in achieving compliance with this section. The agency, in making alterations to existing buildings, shall meet accessibility requirements to the extent compelled by the Architectural Barriers Act of 1968, as amended (42 U.S.C. 4151-4157), and any regulations implementing it. In choosing among available methods for meeting the requirements of this section, the agency shall give priority to those methods that offer programs and activities to qualified handicapped persons in the most integrated setting appropriate.

(2) *Historic preservation programs*. In meeting the requirements of §812.150(a) in historic preservation programs, the agency shall give priority to methods that provide physical access to handicapped persons. In cases where a physical alteration to an historic property is not required because of §812.150(a)(2)

## 36 CFR Ch. VIII (7-1-03 Edition)

or (a)(3), alternative methods of achieving program accessibility include—

(i) Using audio-visual materials and devices to depict those portions of an historic property that cannot otherwise be made accessible;

(ii) Assigning persons to guide handicapped persons into or through portions of historic properties that cannot otherwise be made accessible; or

(iii) Adopting other innovative methods.

(c) *Time period for compliance*. The agency shall comply with the obligations established under this section by October 21, 1986, except that where structural changes in facilities are undertaken, such changes shall be made by August 22, 1989, but in any event as expeditiously as possible.

(d) *Transition plan*. In the event that structural changes to facilities will be undertaken to achieve program accessibility, the agency shall develop, by February 23, 1987, a transition plan setting forth the steps necessary to complete such changes. The agency shall provide an opportunity to interested persons, including handicapped persons or organizations representing handicapped persons, to participate in the development of the transition plan by submitting comments (both oral and written). A copy of the transition plan shall be made available for public inspection. The plan shall, at a minimum—

(1) Identify physical obstacles in the agency's facilities that limit the accessibility of its programs or activities to handicapped persons;

(2) Describe in detail the methods that will be used to make the facilities accessible;

(3) Specify the schedule for taking the steps necessary to achieve compliance with this section and, if the time period of the transition plan is longer than one year, identify steps that will be taken during each year of the transition period; and

(4) Indicate the official responsible for implementation of the plan.

### §812.151 Program accessibility: New construction and alterations.

Each building or part of a building that is constructed or altered by, on



## Advisory Council on Historic Preservation

## § 812.170

behalf of, or for the use of the agency shall be designed, constructed, or altered so as to be readily accessible to and usable by handicapped persons. The definitions, requirements, and standards of the Architectural Barriers Act (42 U.S.C. 4151-4157), as established in 41 CFR 101-19.600 to 101-19.607, apply to buildings covered by this section.

### §§ 812.152-812.159 [Reserved]

#### § 812.160 Communications.

(a) The agency shall take appropriate steps to ensure effective communication with applicants, participants, personnel of other Federal entities, and members of the public.

(1) The agency shall furnish appropriate auxiliary aids where necessary to afford a handicapped person an equal opportunity to participate in, and enjoy the benefits of, a program or activity conducted by the agency.

(i) In determining what type of auxiliary aid is necessary, the agency shall give primary consideration to the requests of the handicapped person.

(ii) The agency need not provide individually prescribed devices, readers for personal use or study, or other devices of a personal nature.

(2) Where the agency communicates with applicants and beneficiaries by telephone, telecommunication devices for deaf person (TDD's) or equally effective telecommunication systems shall be used.

(b) The agency shall ensure that interested persons, including persons with impaired vision or hearing, can obtain information as to the existence and location of accessible services, activities, and facilities.

(c) The agency shall provide signage at a primary entrance to each of its inaccessible facilities, directing users to a location at which they can obtain information about accessible facilities. The international symbol for accessibility shall be used at each primary entrance of an accessible facility.

(d) This section does not require the agency to take any action that it can demonstrate would result in a fundamental alteration in the nature of a program or activity or in undue financial and administrative burdens. In those circumstances where agency per-

sonnel believe that the proposed action would fundamentally alter the program or activity or would result in undue financial and administrative burdens, the agency has the burden of proving that compliance with § 812.160 would result in such alteration or burdens. The decision that compliance would result in such alteration or burdens must be made by the agency head or his or her designee after considering all agency resources available for use in the funding and operation of the conducted program or activity, and must be accompanied by a written statement of the reasons for reaching that conclusion. If an action required to comply with this section would result in such an alteration or such burdens, the agency shall take any other action that would not result in such an alteration or such burdens but would nevertheless ensure that, to the maximum extent possible, handicapped persons receive the benefits and services of the program or activity.

### §§ 812.161-812.169 [Reserved]

#### § 812.170 Compliance procedures.

(a) Except as provided in paragraph (b) of this section, this section applies to all allegations of discrimination on the basis of handicap in programs or activities conducted by the agency.

(b) The agency shall process complaints alleging violations of section 504 with respect to employment according to the procedures established by the Equal Employment Opportunity Commission in 29 CFR part 1613 pursuant to section 501 of the Rehabilitation Act of 1973 (29 U.S.C. 791).

(c) The General Counsel shall be responsible for coordinating implementation of this section. Complaints may be sent to the General Counsel, Advisory Council on Historic Preservation, 1100 Pennsylvania Avenue, NW., Washington, DC 20004.

(d) The agency shall accept and investigate all complete complaints for which it has jurisdiction. All complete complaints must be filed within 180 days of the alleged act of discrimination. The agency may extend this time period for good cause.

**§§ 812.171–812.999**

**36 CFR Ch. VIII (7–1–03 Edition)**

(e) If the agency receives a complaint over which it does not have jurisdiction, it shall promptly notify the complainant and shall make reasonable efforts to refer the complaint to the appropriate government entity.

(f) The agency shall notify the Architectural and Transportation Barriers Compliance Board upon receipt of any complaint alleging that a building or facility that is subject to the Architectural Barriers Act of 1968, as amended (42 U.S.C. 4151–4157), or section 502 of the Rehabilitation Act of 1973, as amended (29 U.S.C. 792), is not readily accessible to and usable by handicapped persons.

(g) Within 180 days of the receipt of a complete complaint for which it has jurisdiction, the agency shall notify the complainant of the results of the investigation in a letter containing—

- (1) Findings of fact and conclusions of law;
- (2) A description of a remedy for each violation found; and
- (3) A notice of the right to appeal.

(h) Appeals of the findings of fact and conclusions of law or remedies must be filed by the complainant within 90 days of receipt from the agency of the letter

required by §812.170(g). The agency may extend this time for good cause.

(i) Timely appeals shall be accepted and processed by the head of the agency.

(j) The head of the agency shall notify the complainant of the results of the appeal within 60 days of the receipt of the request. If the head of the agency determines that additional information is needed from the complainant, he or she shall have 60 days from the date of receipt of the additional information to make his or her determination on the appeal.

(k) The time limits cited in paragraphs (g) and (j) of this section may be extended with the permission of the Assistant Attorney General.

(l) The agency may delegate its authority for conducting complaint investigations to other Federal agencies, except that the authority for making the final determination may not be delegated to another agency.

[51 FR 22896, June 23, 1986, as amended at 51 FR 22893, June 23, 1986]

**§§ 812.171–812.999 [Reserved]**

**PARTS 813–899 [RESERVED]**

## CHAPTER IX—PENNSYLVANIA AVENUE DEVELOPMENT CORPORATION

<i>Part</i>		<i>Page</i>
901	Bylaws of the Corporation .....	151
902	Freedom of Information Act .....	154
903	Privacy Act .....	168
904	Uniform relocation assistance and real property acquisition for Federal and federally assisted programs .....	174
905	Standards of conduct .....	174
906	Affirmative action policy and procedure .....	182
907	Environmental quality .....	188
908	Policy and procedures to facilitate the retention of displaced businesses and residents in the Penn- sylvania Avenue Development Area .....	194
909	Enforcement of nondiscrimination on the basis of handicap in programs or activities conducted by the Pennsylvania Avenue Development Corpora- tion .....	199
910	General guidelines and uniform standards for urban planning and design of development within the Pennsylvania Avenue Development Area .....	205
911-999	[Reserved]	

NOTE: Public Law 104-99, which incorporated the terms of the Department of the Interior and Related Agencies Appropriations Act, 1996 (H.R. 1977), as passed by the House of Representatives on December 13, 1995, provides that the Pennsylvania Avenue Development Corporation terminates as of April 1, 1996. H.R. 1977 provides that "any regulations prescribed by the [Pennsylvania Avenue Development] Corporation in connection with the Pennsylvania Avenue Development Corporation Act of 1972 (40 U.S.C. 871-885) and the Federal Triangle Development Act (40 U.S.C. 1101-1109) shall continue in effect until suspended by regulations prescribed by the Administrator of the General Services Administration." Accordingly, the authority to administer the regulations in 36 CFR Chapter IX is transferred to the General Services Administration. See the Pennsylvania Avenue Development Corporation document, "Transfer of Responsibilities and Effectiveness of PADC Regulations After PADC Termination", published at 61 FR 11308, March 20, 1996.



## PART 901—BYLAWS OF THE CORPORATION

Sec.	
901.1	Title and office.
901.2	Establishment.
901.3	Board of directors.
901.4	Officers.
901.5	Annual report.
901.6	Seal.
901.7	Amendments.

AUTHORITY: Sec. 6(5), Pub. L. 92-578, 88 Stat. 1270(5) (40 U.S.C. 875(5)).

SOURCE: 40 FR 41524, Sept. 8, 1975, unless otherwise noted.

### § 901.1 Title and office.

(a) *Title.* The name of the Corporation is the Pennsylvania Avenue Development Corporation.

(b) *Office.* The office of the Corporation shall be in the city of Washington, District of Columbia.

### § 901.2 Establishment.

(a) *Creation.* The Corporation, a wholly owned instrumentality of the United States subject to the Government Corporation Control Act (31 U.S.C. 841 *et seq.*), was established by the Pennsylvania Avenue Development Corporation Act of 1972 (Pub. L. 92-578, 86 Stat. 1266 (40 U.S.C. 871 *et seq.*)), as amended, hereinafter referred to as *the Act*.

(b) *Purposes.* The purposes for which this Corporation was established are those stated and promulgated by Congress in the Act.

### § 901.3 Board of directors.

(a) *Powers and responsibilities.* The business, property and affairs of the Corporation shall be managed and controlled by the Board of Directors, and all powers specified in the Act are vested in them. The Board may, at its discretion and as hereinafter provided, delegate authority necessary to carry on the ordinary operations of the Corporation to officers and staff of the Corporation.

(b) *Composition; number; selection; terms of office.* The Board of Directors shall be comprised of fifteen voting members and eight nonvoting members. The powers and management of the Corporation shall reside with the fifteen voting members, and the proce-

dures of the Board shall be determined by them.

(1) The fifteen voting members shall include the seven government agency representatives specified in subsection 3(c) of the Act (or, their designees), and eight individuals meeting the qualifications of that subsection, appointed by the President of the United States from private life, at least four of whom shall be residents and registered voters of the District of Columbia.

(2) The Chairman and Vice Chairman shall be designated by the President of the United States from among those members appointed from private life.

(3) Upon his appointment, the Chairman shall invite the eight representatives designated in subsection 3(g) of the Act to serve as non-voting members of the Board of Directors.

(4) Each member of the Board of Directors appointed from private life shall serve a term of six years from the expiration of his predecessor's term; except that the terms of the Directors first taking office shall begin on October 27, 1972 and shall expire as designated at the time of appointment. A Director may continue to serve until his successor has qualified.

(5) A Director appointed from private life wishing to resign shall submit a letter of resignation to the President of the United States, and his resignation shall become effective upon the date of the President's acceptance thereof.

(6) A Director, appointed to fill a vacancy occurring prior to the expiration of the term for which his predecessor was appointed, shall serve for the remainder of such term.

(c) *Meetings.* (1) The Board of Directors shall meet and keep its records at the office of the Corporation.

(2) Meetings of the Board of Directors shall be held at the call of the Chairman, but not less often than once every three months. The Chairman shall also call a meeting at the written request of any five voting members.

(3) The Chairman shall direct the Secretary to give the members of the Board notice of each meeting, either personally, or by mail, or by telegram, stating the time, the place and the agenda for the meeting. Notice by telephone shall be personal notice. Any Director may waive, in writing, notice as

### § 901.3

### 36 CFR Ch. IX (7-1-03 Edition)

to himself, whether before or after the time of the meeting, and the presence of a Director at any meeting shall constitute a waiver of notice of that meeting. Notice, in whatever form, shall be given so that a Director will have received it five working days prior to the time of the meeting.

(4) Unless otherwise limited by the notice thereof, any and all Corporation business may be transacted at any meeting.

(5) The Chairman shall preside at meetings of the Board of Directors, or the Vice Chairman in the absence of the Chairman. In the event of the absence of both the Chairman and the Vice Chairman, the Directors present at the meeting shall designate a Presiding Officer.

(d) *Quorum.* The presence of a majority of the number of voting Directors serving at the time of a meeting of the Board shall constitute a quorum for the transaction of business at such meeting of the Board. The act of a majority of the voting Directors at any meeting at which there is a quorum shall be an act of the Board of Directors. If there shall be less than a quorum at any meeting, a majority of the voting Directors present may adjourn the meeting until such time as a quorum can practically and reasonably be obtained.

(e) *Directors serving in stead.* Each member of the Board of Directors specified in paragraphs (1) through (7) of subsection 3(c) of the Act, if unable to serve in person, may designate up to two officials from his agency or department to serve on the Board in his stead. Such designation shall be effected by a letter of appointment, from the Director specified in the Act, received by the Chairman prior to or at a meeting of the Board of Directors. If two officials are so designated, then the Director specified in the Act shall identify one as the First Designee and the other as the Second Designee. The Second Designee may only serve as a Director if the First Designee is not in attendance at a meeting of the Board of Directors. An official designated to serve in stead shall serve as the voting Director of the represented agency until the Chairman receives written notice from the Director specified in

the Act, or his successor, that the designation is rescinded.

(f) *Vote by proxy.* Voting members of the Board of Directors unable to attend a meeting may vote by proxy on resolutions which have been printed in the agenda in advance for the meeting.

(1) A Director unable to attend a meeting of the Board may submit a vote to be cast by the Presiding Officer by means of a written signed statement of his vote and the resolution to which it pertains together with any statement bearing on the matter the Director wishes to have read. The proxy vote shall be submitted to the Chairman with a separate signed copy to the Secretary, to be received not later than the close of business of the day prior to the date fixed for the meeting.

(2) The Presiding Officer shall cast proxy votes received by the Chairman in the following manner:

(i) Upon the close of discussion on a resolution for which there has been submitted one or more valid proxy votes, the Presiding Officer shall announce that he holds proxy vote(s) from named Director(s), and shall read any explanatory statements submitted by the Director(s) voting by proxy;

(ii) The Presiding Officer shall take the vote of the Directors present and then declare the proxy votes in hand;

(iii) The Secretary shall orally verify the validity of the votes submitted to be cast by proxy, and shall record them with the votes cast by the Directors present on the resolution.

(3) Proxy votes shall not be utilized to effect the presence of a quorum.

(g) *Compensation of Directors.* Members of the Board of Directors shall be compensated in the manner provided in section 3 of the Act.

(h) *Approval of annual budget.* Upon completion by the staff of a draft annual budget request, the Chairman shall call a meeting of the Board of Directors for its review and consideration. Upon approval by the Board of the draft budget request, it may be submitted to the Office of Management and Budget.

[40 FR 41524, Sept. 8, 1975, as amended at 48 FR 20903, May 10, 1983]

§ 901.4 **Officers.**

(a) *General provisions.* The corporate officers of the Corporation shall consist of a President, an Executive Director, two Assistant Directors, a Secretary (who shall be appointed by the Chairman from among the staff of the Corporation), and such other officers as the Board of Directors may from time-to-time appoint. Any corporate officer elected or appointed by the Board of Directors may be removed at any time, with or without cause, by the affirmative vote of a majority of the Board of Directors.

(b)(1) *Powers and duties of the President.* The Chairman of the Board of Directors shall be the President and chief executive officer of the Corporation and shall have the general powers and duties of supervision and management usually vested in the office of a president of a corporation. The President shall see that all resolutions and policies of the Board are carried into effect, and shall have power to execute contracts, leases, agreements, and other documents necessary for the operation of the Corporation.

(2) *Assumption of powers and duties by Vice Chairman.* In the event that the position of Chairman becomes vacant, the Vice Chairman shall promptly notify the President of the United States in writing to that effect and upon giving such notice, shall assume the Chairman's powers and duties as President and Chief Executive Officer of the Corporation, including specific powers and duties delegated to the Chairman by the Board of Directors. Such assumption of the Chairman's powers and duties shall cease upon the appointment or designation of a new Chairman or Acting Chairman by the President of the United States. The Vice Chairman shall also assume the powers and duties of the Chairman in the event of the latter's incapacity, if the Chairman so requests in writing, or if a majority of the voting members of the Board of Directors finds by resolution that the Chairman is unable to exercise the powers and duties of his office. Such assumption of the Chairman's powers and duties shall cease upon the Vice Chairman's receipt of a letter from the Chairman stating that he or she is able

to resume the exercise of the powers and duties of his office.

(c) *Appointment of certain officers.* The Board of Directors shall appoint an Executive Director and two Assistant Directors, who may be appointed and compensated without regard to the provisions of title 5 U.S.C. governing appointments in the competitive service and chapter 51 and subchapter IV of chapter 53 of title 5 U.S.C. Between meetings of the Board of Directors the Chairman may make appointments to the foregoing positions, when they become vacant by resignation or otherwise. However, the Chairman shall move to have such interim appointments confirmed at the next meeting of the Board. The Chairman shall have power to increase or decrease the salaries of the officers appointed under this section.

(d) *Powers and duties of the Executive Director.* The Executive Director shall be the chief of the Corporation's staff and shall have general powers of supervision and management over the administration of the Corporation. The Executive Director shall have power to:

- (1) Execute contracts, agreements, and other documents necessary for planning and design work and for ordinary operations of the Corporation.
- (2) Hire staff (including temporary or intermittent experts and consultants).
- (3) Procure space, equipment, supplies, and obtain interagency and commercial support services.
- (4) Direct and manage the day-to-day operations and work of the Corporation.
- (5) Supervise planning and development activities of the Corporation in accordance with the development plan and resolutions of the Board of Directors.
- (6) Perform such other duties and exercise such powers as the President and Board of Directors may prescribe.

(e) *Powers and duties of the Assistant Director/Legal.* The Assistant Director/Legal shall be the General Counsel of the Corporation, advising the Board of Directors and the staff on all legal matters affecting the functioning of the Corporation. He shall:

- (1) Coordinate with the Department of Justice in assuring that the interests of the Corporation are represented

## § 901.5

in any litigation arising from its authorities or actions.

(2) Advise the Board of Directors and the staff of statutory or regulatory requirements, and assure compliance therewith.

(3) Prepare or review all contracts, agreements or other documents of a legal nature.

(4) Prepare or review all draft legislation, regulations, official notices and other legal publications.

(5) Perform such other duties as may be prescribed by the Board of Directors, the President, or the Executive Director.

(f) *Powers and duties of the Assistant Director/Development.* The Assistant Director/Development shall advise the Board of Directors, officers and staff of the Corporation on all development activities to accomplish the goals of the development plan. He shall:

(1) Manage development activities in accordance with the development plan.

(2) Function as a key management official performing a wide range of duties required to accomplish the rebuilding of Pennsylvania Avenue.

(3) Provide managerial responsibility for the work of all project managers and consultants relating to development projects.

(4) Coordinate the tasks of other staff professionals as required for accomplishment of projects.

(5) Be liaison between the Corporation and other governmental agencies that review projects in the development area.

(6) Perform such other duties as may be prescribed by the Board of Directors, the President, or the Executive Director.

(g) *Powers and Duties of the Secretary.* The Secretary, to be appointed by the Chairman from among the Corporation's staff, shall give notice of all meetings of the Board of Directors and record and keep the minutes thereof, keep in safe custody the seal of the Corporation, and shall affix the same to any instrument requiring it. When so affixed, the seal shall be attested by the signature of the Secretary. The Secretary shall also perform such other duties as may be prescribed by the

## 36 CFR Ch. IX (7-1-03 Edition)

Board of Directors, the President, or the Executive Director.

[40 FR 41524, Sept. 8, 1975, as amended at 47 FR 34536, Aug. 10, 1982]

### § 901.5 Annual report.

The Executive Director shall prepare annually a comprehensive and detailed report of the Corporation's operations, activities, and accomplishments for the review of the Board of Directors. Upon approval by the Board, the Chairman shall transmit the report in January of each year to the President of the United States and to the Congress.

### § 901.6 Seal.

The Corporation may adopt a corporate seal which shall have the name of the Corporation and year of incorporation printed upon it. The seal may be used by causing it or a facsimile thereof to be impressed, affixed, or reproduced.

### § 901.7 Amendments.

These bylaws may be altered, amended, or repealed by the Board of Directors at any meeting, if notice of the proposed alteration, amendment, or repeal is contained in the notice of the meeting.

## PART 902—FREEDOM OF INFORMATION ACT

### Subpart A—Applicability and Policy

- Sec.  
902.01 Purpose and applicability.  
902.02 Statement of policy.  
902.03 Definitions.

### Subpart B—General Administration

- 902.10 Delegation of administration of this part.  
902.11 How records may be requested.  
902.12 Maintenance of statistics; annual report to Congress.  
902.13 Indexes of Corporation records.  
902.14 Deletion of nondiscloseable information from requested records.  
902.15 Protection of records.

### Subpart C—Publication in the Federal Register

- 902.20 Applicability.  
902.21 Publication in the FEDERAL REGISTER shall be constructive notice of information that affects the public.



**Subpart D—Availability of Records Not Published in the Federal Register**

- 902.30 Applicability.
- 902.31 Access, inspection and copying.

**Subpart E—Availability of Reasonably Described Records**

- 902.40 Applicability.
- 902.41 Public access to reasonably described records.
- 902.42 Request for records of concern to more than one government organization.

**Subpart F—Exemptions From Public Access to Corporation Records**

- 902.50 Applicability.
- 902.51 Records relating to matters that are required by Executive order to be kept secret.
- 902.52 Records related solely to internal personnel rules and practices.
- 902.53 Records exempted from disclosure by statute.
- 902.54 Trade secrets and commercial or financial information that is privileged or confidential.
- 902.55 Intragovernmental exchanges.
- 902.56 Protection of personal privacy.
- 902.57 Investigatory files compiled for law enforcement purposes.
- 902.58 Reports of financial institutions.
- 902.59 Geological and geophysical information.

**Subpart G—Time Limitations**

- 902.60 Initial determination.
- 902.61 Final determination.
- 902.62 Extension of time limits.

**Subpart H—Procedures for Administrative Appeal of Decisions Not To Disclose Records**

- 902.70 General.
- 902.71 Forms for appeal.
- 902.72 Time limitations on filing an appeal.
- 902.73 Where to appeal.
- 902.74 Agency decision.

**Subpart I—Fees**

- 902.80 General.
- 902.81 Payment of fees.
- 902.82 Fee schedule.
- 902.83 Waiver or reduction of fees.

AUTHORITY: 5 U.S.C. 552; 52 FR 10012-10019 (March 27, 1987); E.O. 12600, 52 FR 23781 (June 23, 1987).

SOURCE: 41 FR 43143, Sept. 30, 1976, unless otherwise noted.

**Subpart A—Applicability and Policy**

**§ 902.01 Purpose and applicability.**

This part contains regulations of the Corporation implementing 5 U.S.C. 552, as amended. It informs the public about where and how the Corporation's records may be obtained. The following provisions are applicable to all records of the Corporation in existence at the time a request for records is made. The regulations establish fee schedules applicable to the search and copying of requested records. This part identifies the officials having authority to act on requests and prescribes the procedures to appeal decisions which initially deny disclosure. Indexes maintained to reflect all records subject to this part are available for public inspection and copying as provided herein.

**§ 902.02 Statement of policy.**

In keeping with the spirit of the Freedom of Information Act, 5 U.S.C. 552, the policy of the Corporation is one of full and responsible disclosure of its records to the public. Therefore, all records of the Corporation, unless otherwise exempted under subpart F of this part, are declared to be available for public inspection and copying. Each officer and employee of the Corporation is directed to cooperate to this end and shall make records available to the public with reasonable promptness. A record may not be withheld from the public solely because its release might suggest administrative error or embarrass an officer or employee of the Corporation.

**§ 902.03 Definitions.**

As used in this part—

(a) *Act* means section 552 of title 5 U.S.C., as amended, Pub. L. 90-23, 81 Stat. 54, June 5, 1967; as amended, Pub. L. 93-502, 88 Stat. 1561, November 11, 1974. Pub. L. 90-23 repealed and superseded Pub. L. 89-487, 80 Stat. 250. July 4, 1966, sometimes referred to as the *Freedom of Information Act* or *Public Information Act*.

(b) *Chairman* means the Chairman of the Corporation's Board of Directors and President of the Corporation.

**§ 902.10**

**36 CFR Ch. IX (7-1-03 Edition)**

(c) *Corporation* means the Pennsylvania Avenue Development Corporation, including the Board of Directors, Executive Officers, Corporation staff, and any subordinate organizational units operating under the Pennsylvania Avenue Development Corporation Act of 1972, Pub. L. 92-578, 86 Stat. 1266 (40 U.S.C. 871 *et seq.*), as amended.

(d) *Person* means *person* as defined in 5 U.S.C. 551(2).

(e) *Records* means any and all writing, drawings, maps, recordings, tapes, films, slides, photographs, or other documentary materials by which information is preserved.

(f) *Submitter* means any person or entity that provides or has provided information to the Corporation or about which the Corporation possess records subject to Exemption 4 of the Freedom of Information Act.

(g) *Workday* means a calendar day excluding Saturday, Sunday and Federal holidays, office hours being 9 a.m. to 5 p.m.

[41 FR 43143, Sept. 30, 1976, as amended at 53 FR 10374, Mar. 31, 1988]

**Subpart B—General Administration**

**§ 902.10 Delegation of administration of this part.**

Except as provided in subpart H of this part, authority to administer this part is delegated to the Administrative Officer, who shall act upon all requests for access to records which are received by the Corporation from any person citing the Act.

[41 FR 43143, Sept. 30, 1976, as amended at 48 FR 17354, Apr. 22, 1983]

**§ 902.11 How records may be requested.**

In accordance with § 902.41 of subpart E of this part all requests for records shall be made to the Administrative Officer, Pennsylvania Avenue Development Corporation, 1331 Pennsylvania Avenue, NW, Suite 1220 North, Washington, DC 20004.

[41 FR 43143, Sept. 30, 1976, as amended at 48 FR 17354, Apr. 22, 1983; 50 FR 45824, Nov. 4, 1985]

**§ 902.12 Maintenance of statistics; annual report to Congress.**

(a) The Administrative Officer shall maintain records of:

(1) The fees collected by the Corporation for making records available under this part;

(2) The number of denials of requests for records made under this part, and the reasons for each denial;

(3) The number of appeals arising from denials, the result of each appeal, and the reasons for the action upon each appeal that results in a denial of information;

(4) The names and titles or positions of each person responsible for each denial of records requested under this part, and the number of instances of participation for each person;

(5) The results of each proceeding conducted pursuant to subsection 552(a)(4)(f) of title 5, U.S.C., including a report of the disciplinary action against the official or employee who was primarily responsible for improperly withholding records or an explanation of why disciplinary action was not taken;

(6) Every rule made by the Corporation affecting or implementing the Act;

(7) The fee schedule listing fees for search and duplication of records pursuant to request under the Act; and

(8) All other information which indicates efforts to administer fully the letter and spirit of the Act.

(b) The Administrative Officer shall annually prepare a report accounting for each item in paragraph (a) of this section for the prior calendar year. On or before March 1st of each year, the report shall be submitted to the Speaker of the House of Representatives and the President of the Senate for referral to the appropriate committees of Congress.

[41 FR 43143, Sept. 30, 1976, as amended at 48 FR 17354, Apr. 22, 1983]

**§ 902.13 Indexes of Corporation records.**

(a) The Administrative Officer shall be responsible for maintenance, publication, distribution and availability for inspection and copying of the current indexes and supplements which are required by 5 U.S.C. (a)(2). Such indexes

## Pennsylvania Avenue Development Corporation

## § 902.20

shall be published promptly on a quarterly basis unless the Chairman determines by order published in the FEDERAL REGISTER that the publication would be unnecessary and impractical.

(b) The index of materials under this subpart covers all materials issued, adopted, or promulgated after July 4, 1967 by the Corporation. However, earlier materials may be included in the index to the extent practicable. Each index contains instruction for its use.

[41 FR 43143, Sept. 30, 1976, as amended at 48 FR 17354, Apr. 22, 1983]

### § 902.14 Deletion of nondiscloseable information from requested records.

Whenever a requested record contains information which falls within one of the exempted categories of subpart F of this part, identifying details shall be deleted from the record before it is made available for public inspection and copying. When a requested record contains both discloseable and nondiscloseable information, only that portion which is reasonably segregable after deletion of the nondiscloseable portions, will be released. If the information in the discloseable portion is readily available from another source and that source is made known to the person making the request, the Corporation need not disclose the requested record. In all cases where a deletion is made, an explanation of the deletion shall be attached to the record made available for inspection, distribution, or copying. Appeal of deletions shall be made in accordance with subpart H of this part.

### § 902.15 Protection of records.

(a) No person may, without permission of the Administrative Officer, remove from the Corporation's offices any record made available to him for inspection or copying. In addition, no person may steal, alter, mutilate, obliterate, or destroy, in whole or in part, such a record.

(b) Section 641 of title 18 U.S.C. provides, in pertinent part, as follows:

(1) Whoever \* \* \* steals, purloins, knowingly converts to his use or the use of any other or without authority sells, conveys or disposes of any record \* \* \* or thing of value

shall be fined not more than \$10,000 or imprisoned not more than 10 years or both; but if the value of such property does not exceed the sum of \$100, he shall be fined not more than \$1,000 or imprisoned not more than one year or both. \* \* \*

(c) Section 2071 of title 18 U.S.C. provides, in pertinent part, as follows:

(1) Whoever willfully and unlawfully conceals, removes, mutilates, obliterates, or destroys, or attempts to do so, or with intent to do so takes and carries away any record, proceeding, map, book, paper document, or other thing, filed or deposited \* \* \* in any public office, or with any \* \* \* public officer of the United States, shall be fined not more than \$2,000 or imprisoned not more than 3 years, or both.

[41 FR 43143, Sept. 30, 1976, as amended at 48 FR 17354, Apr. 22, 1983]

## Subpart C—Publication in the Federal Register

### § 902.20 Applicability.

Subject to the exemptions in subpart F of this part, the Corporation, for the guidance of the public, shall submit to the Director of the Federal Register for publication—

(a) Descriptions of the Corporation's organization and functional responsibilities and the designation of places at which the public may secure information, obtain forms and applications, make submittals or requests, or obtain decisions:

(b) Statements of the general course and method by which the Corporation's functions are channeled and determined, including the nature and requirements of all formal and informal procedures available;

(c) Rules of procedure, descriptions of forms available, and instructions as to the scope and contents of all papers, reports, or examinations;

(d) Substantive rules of general applicability adopted as authorized by law, and statements of general policy or interpretations of general applicability; and,

(e) Each amendment, revision, or repeal of the foregoing.

## § 902.21

### **§ 902.21 Publication in the Federal Register shall be constructive notice of information that affects the public.**

(a) All material described in § 902.20 shall be published in the FEDERAL REGISTER. For the purpose of this section, material that is reasonably available to the class of persons affected by it is considered to be published in the FEDERAL REGISTER when it is incorporated by reference with the approval of the Director of the Federal Register.

(b) Publication in the FEDERAL REGISTER of all relevant information shall be considered constructive notice of information that affects the public, except that no person shall be required to resort to or be adversely affected by any matter which is required to be published in the FEDERAL REGISTER and is not so published unless such person has actual and timely notice of the terms of the unpublished matter.

## **Subpart D—Availability of Records Not Published in the Federal Register**

### **§ 902.30 Applicability.**

(a) This subpart implements section 552(a)(2) of title 5 U.S.C., as amended by 88 Stat. 1561 (1974). It prescribes the rules governing the availability for public inspection and copying of the following:

(1) Final opinions or orders (including concurring and dissenting opinions, if any) made in the adjudication of cases;

(2) Statements of policy or interpretations which have been adopted under the authority of the Corporation's enabling act, including statements of policy or interpretation concerning a particular factual situation. If they can reasonably be expected to have precedential value in any case involving a member of the public in a similar situation, and have not been published in the FEDERAL REGISTER.

(3) Administrative staff manuals or instructions to the staff of the Corporation which affects any member of the public. Included within this category are manuals or instructions which prescribe the manner or performance of any activity by any person. Excepted from this category are

## 36 CFR Ch. IX (7-1-03 Edition)

staff manuals or instructions to staff concerning internal operating rules, practices, guidelines and procedures for Corporation negotiators and inspectors, the release of which would substantially impair the effective performance of their duties.

(4) Documents and materials offered for sale under the auspices of the Corporation.

(5) Any index of materials which is required to be maintained by the Corporation under § 902.13.

(b) Records listed in paragraph (a) of this section, which the Corporation does not make available for public inspection and copying, or that are not indexed as required by § 902.13, may not be cited, relied upon, or used as a precedent by the Corporation to adversely affect any person, unless the person against whom it is cited, relied upon, or used, has had actual and timely notice of that material.

(c) This subpart shall not apply to information published in the FEDERAL REGISTER or that is a reasonably described record covered by subpart E of this part.

### **§ 902.31 Access, inspection and copying.**

(a) Records listed in § 902.30(a), are available for inspection and copying by any person at the Corporation's office, 1331 Pennsylvania Avenue, NW., Suite 1220 North, Washington, DC 20004. Facilities for inspection and copying shall be open to the public every workday.

(b) Records listed in § 902.30(a), that are published and offered for sale, shall be indexed as required under § 902.13, and shall be available for public inspection. Records offered for sale will not be copied by the Corporation for the requester without the approval of the Administrative Officer.

(c) Records listed in § 902.30(a) are subject to subpart F of this part and access may be restricted by the Corporation in accordance with that subpart. A refusal to disclose may be appealed by the requester under the provisions of subpart H of this part.

[41 FR 43143, Sept. 30, 1976, as amended at 48 FR 17354, Apr. 22, 1983; 50 FR 45824, Nov. 4, 1985]

**Subpart E—Availability of Reasonably Described Records**

**§ 902.40 Applicability.**

This subpart implements section 552(a)(3) of title 5 U.S.C., as amended, and prescribes regulations governing public inspection and copying of reasonably described records in the Corporation's custody. This subpart shall not apply to material which is covered by subparts C and D of this part, and records exempted under subpart F of this part.

**§ 902.41 Public access to reasonably described records.**

(a) Any person desiring access to a record covered by this subpart may make request for records and copies either in person on any workday at the Corporation's office, or by written request. In either instance, the requester must comply with the following provisions;

(1) A written request must be made for the record;

(2) The request must indicate that it is being made under the Freedom of Information Act (section 552 of title 5 U.S.C.); and

(3) The request must be addressed to the attention of the Administrative Officer, as provided in §902.11.

(b) Each request for a record should reasonably describe the particular record sought. The request should specify, to the extent possible, the subject matter of the record, the date when it was made, the place where it was made and the person who made it. If the description is insufficient to process the request, the Public Information offices shall promptly notify the person making the request and solicit further information. The Administrative Officer may assist the person in perfecting the request.

(c) Requests made in person at the Corporation's office during regular working hours (9 a.m. to 5 p.m., Monday through Friday, except Federal holidays) shall be processed as provided in subpart G of this part. The Corporation shall provide adequate inspection and copying facilities. Original records may be copied, but may not be released

from the custody of the Corporation. Upon payment of the appropriate fee, copies will be provided to the requester by mail or in person.

(d) Every effort will be made to make a record in use by the staff of the Corporation available when requested, and availability may be deferred only to the extent necessary to avoid serious interference with the business of the Corporation.

(e) Notwithstanding paragraphs (a) through (d) of this section, informational materials and services, such as press releases, and similar materials prepared by the Corporation, shall be made available upon written or oral request. These services are considered as part of any informational program of the Government and are readily made available to the public. There is no fee for individual copies of such materials as long as they are in supply. In addition, the Corporation will continue to respond, without charge, to routine oral or written inquiries that do not involve direct access to records of the Corporation.

[41 FR 43143, Sept. 30, 1976, as amended at 48 FR 17354, Apr. 22, 1983]

**§ 902.42 Request for records of concern to more than one government organization.**

(a) If the release of a record covered by this subpart would be of concern to both the Corporation and another Federal agency, the record will be made available only after consultation with the other agency concerned. Records of another agency in the Corporation's possession will not be disclosed without the approval of the other agency.

(b) If the release of a record covered by this subpart would be of concern to both the Corporation and to a foreign, state or local government, the record will be made available by the Corporation only after consultation with the other interested foreign state or local government. Records of a foreign, state or local government will not be disclosed without the approval of the government concerned.

### Subpart F—Exemptions From Public Access to Corporation Records

#### § 902.50 Applicability.

(a) This subpart implements section 552(b) of title 5 U.S.C., which exempts certain records from public inspection under section 552(a). This subpart applies to records requested under subparts D and E of this part. The Corporation may, however, release a record authorized to be withheld under §§ 902.52 through 902.59 unless it determines that the release of that record would be inconsistent with a purpose of the aforementioned sections. Examples given in §§ 902.52 through 902.59 of records included within a particular statutory exemption are not necessarily illustrative of all types of records covered by the exemption. Any reasonably segregable portion of a record withheld under this subpart shall be provided to a requester, after deletion of the portions which are exempt under this subpart.

(b) This subpart does not authorize withholding of information or limit the availability of records to the public, except as specifically stated. This subpart is not authority to withhold information from Congress.

#### § 902.51 Records relating to matters that are required by Executive order to be kept secret.

Records relating to matters that are specifically authorized under criteria established by an Executive order to be kept secret in the interest of national defense or foreign policy, include those within the scope of the following, and any further amendment of any of them, but only to the extent that the records are in fact properly classified pursuant to such Executive order:

(a) Executive Order 11652 of March 8, 1972 (3 CFR 1974 Comp. p. 339);

(b) Executive Order 10865 of February 20, 1960 (3 CFR 1959-1963 Comp. p. 398); and

(c) Executive Order 10104 of February 1, 1950 (3 CFR 1949-1953 Comp., p. 298).

These records may not be made available for public inspection.

#### § 902.52 Records related solely to internal personnel rules and practices.

(a) Records related solely to internal personnel rules and practices that are within the statutory exemption include memoranda pertaining to personnel matters such as staffing policies, and policies and procedures for the hiring, training, promotion, demotion, and discharge of employees, and management plans, records, or proposals related to labor-management relationships.

(b) The purpose of this section is to authorize the protection of any record related to internal personnel rules and practices dealing with the relations between the Corporation and its employees.

#### § 902.53 Records exempted from disclosure by statute.

(a) Records relating to matters that are specifically exempted by statute from disclosure may not be made available for public inspection. For example: section 1905 of title 18 U.S.C., protecting trade secrets, processes, and certain economic and other data obtained by examination or investigation, or from reports.

(b) The purpose of this section is to preserve the effectiveness of statutes of the kind cited as an example, in accordance with their terms.

#### § 902.54 Trade secrets and commercial or financial information that is privileged or confidential.

(a) Trade secrets and commercial or financial information that are privileged and for which confidentiality is requested by the person possessing such privilege are within the statutory exemption. This includes the following:

(1) Commercial or financial information not customarily released to the public, furnished and accepted in confidence or disclosure of which could reasonably be expected to cause substantial competitive harm, or both;

(2) Statements of financial interest furnished by officers and employees of the Corporation;

(3) Commercial, technical, and financial information furnished by any person in connection with an application for a loan or a loan guarantee;

(4) Commercial or financial information customarily subjected to an attorney-client or similar evidentiary privilege; or,

(5) Materials in which the Corporation has a property right such as designs, drawings, and other data and reports acquired in connection with any research project, inside or outside of the Corporation, or any grant or contract.

(b) The purpose of this section is to authorize the protection of trade secrets and commercial or financial records that are customarily privileged or are appropriately given to the Corporation in confidence. It assures the confidentiality of trade secrets and commercial or financial information obtained by the Corporation through questionnaires and required reports to the extent that the information would not customarily be made public by the person from whom it was obtained. In any case in which the Corporation has obligated itself not to disclose trade secrets and commercial or financial information it receives, this section indicates the Corporation's intention to honor that obligation to the extent permitted by law. In addition, this section recognizes that certain materials, such as research data and materials, formulae, designs, and architectural drawings, have significance not as records but as items of property acquired, in many cases at public expense. In any case in which similar proprietary material in private hands would be held in confidence, material covered in this section may be held in confidence.

(c)(1) *In general.* For commercial or financial information furnished to the Corporation on or after March 30, 1988, the Corporation shall require the submitter to designate, at the time the information is furnished or within a reasonable time thereafter, any information the submitter considers confidential or privileged. Commercial or financial information provided to the Corporation shall not be disclosed pursuant to a Freedom of Information Act request except in accordance with this paragraph.

(2) *Notice to submitters.* The Corporation shall provide a submitter with prompt written notice of a request encompassing its commercial or financial

information whenever required under paragraph (c)(3) of this section, and except as is provided in paragraph (c)(7) of this section. Such written notice shall either describe the exact nature of the information requested or provide copies of the records or portions thereof containing the information. Concurrently with its notice to a submitter, the Corporation shall inform a requestor in writing that the submitter is afforded a reasonable period within which to object to disclosure and that the 10 workday initial determination period provided for in 36 CFR 902.60 may therefore be extended.

(3) *When notice is required.* (i) For information submitted to the Corporation prior to March 30, 1988, the Corporation shall provide a submitter with notice of a request whenever:

(A) The information is less than ten years old;

(B) The information is subject to prior express commitment of confidentiality given by the Corporation to the submitter; or

(C) The Corporation has reason to believe that disclosure of the information may result in substantial competitive harm to the submitter.

(ii) For information submitted to the Corporation on or after March 30, 1988, the Corporation shall provide a submitter with notice of a request whenever:

(A) The submitter has in good faith designated the information as confidential, or

(B) The Corporation has reason to believe that disclosure of the information may result in substantial competitive harm to the submitter.

Notice of a request for information falling within the former category shall be required for a period of not more than ten years after the date of submission unless the submitter requests, and provides acceptable justification for, a specific notice period of greater duration. The submitter's claim of confidentiality should be supported by a statement or certification by an officer or authorized representative that the information in question is in fact confidential and has not been disclosed to the public.

**§ 902.55**

**36 CFR Ch. IX (7-1-03 Edition)**

(4) *Opportunity to object to disclosure.* Through the notice described in paragraph (c)(2) of this section, the Corporation shall afford a submitter a reasonable period within which to provide the Corporation with a detailed statement of any objection to disclosure. Such statement shall specify all grounds for withholding any of the information under any exemption of the Freedom of Information Act and, in the case of Exemption 4, shall demonstrate why the information is contended to be privileged or confidential. Information provided by a submitter pursuant to this paragraph may itself be subject to disclosure under the Freedom of Information Act.

(5) *Notice of intent to disclose.* The Corporation shall consider carefully a submitter's objections and specific grounds for nondisclosure prior to determining whether to disclose information. Whenever the Corporation decides to disclose information over the objection of a submitter, the Corporation shall forward to the submitter a written notice which shall include:

- (i) A statement of the reasons for which the submitter's disclosure objections were not sustained;
- (ii) A description of the information to be disclosed; and
- (iii) A specified disclosure date.

Such notice of intent to disclose shall be forwarded a reasonable number of days, as circumstances permit, prior to the specified date upon which disclosure is intended. A copy of such disclosure notice shall be forwarded to the requester at the same time.

(6) *Notice of lawsuit.* Whenever a requester brings suit seeking to compel disclosure of information covered by paragraph (c) of this section, the Corporation shall promptly notify the submitter.

(7) *Exceptions to notice requirements.* The notice requirements of this section shall not apply if:

- (i) The Corporation determines that the information should not be disclosed;
- (ii) The information lawfully has been published or otherwise made available to the public;
- (iii) Disclosure of the information is required by law (other than 5 U.S.C. 552); or

(iv) The designation made by the submitter in accordance with paragraphs (c)(1) and (c)(3)(ii) of this section appears obviously frivolous; except that, in such case, the Corporation shall provide the submitter with written notice of any final decision to disclose information within a reasonable number of days prior to a specified disclosure date.

[41 FR 43143, Sept. 30, 1976, as amended at 53 FR 10374, Mar. 31, 1988]

**§ 902.55 Intragovernmental exchanges.**

(a) Any record prepared by a Government officer or employee (including those prepared by a consultant or advisory body) for internal Government use is within the statutory exemption to the extent that it contains—

(1) Opinions, advice, deliberations, or recommendations made in the course of developing official action by the Government, but not actually made a part of that official action, or

(2) Information concerning any pending proceeding or similar matter including any claim or other dispute to be resolved before a court of law, administrative board, hearing officer, or contracting officer.

(b) This section has two distinct purposes. One is to protect the full and frank exchange of ideas, views, and opinions necessary for the effective functioning of the Government and to afford this protection both before and after any action is taken. This judicially recognized privilege of protection against disclosure in litigation or elsewhere is intended to assure that these resources will be fully and readily available to those officials upon whom the responsibility rests to take official and final Corporation action. However, the action itself, any memoranda made part of that action, and the facts on which it is based are not within this protection. The other purpose is to protect against the premature disclosure of material that is in the development stage if premature disclosure would be detrimental to the authorized and appropriate purposes for which the material is being used, or if, because of its tentative nature, the material is likely to be revised or modified before it is officially presented to the public.



(c) Examples of records covered by this section include minutes to the extent they contain matter described in paragraph (a) of this section; staff papers containing advice, opinions, suggestions, or exchanges of views, preliminary to final agency decision or action; budgetary planning and programming information; advance information on such things as proposed plans to procure, lease, or otherwise hire and dispose of materials, real estate, or facilities, documents exchanged preparatory to anticipated legal proceedings; material intended for public release at a specified future time, if premature disclosure would be detrimental to orderly processes of the Corporation; records of inspection, investigations, and surveys pertaining to internal management of the Department; and matters that would not be routinely disclosed under disclosure procedures in litigation and which are likely to be the subject of litigation. However, if such a record also contains factual information, that information must be made available under subpart E of this part unless the facts are so inextricably intertwined with deliberative or policymaking processes, that they cannot be separated without disclosing those processes.

**§902.56 Protection of personal privacy.**

(a) Any of the following personnel, medical, or similar records is within the statutory exemption if its disclosure would harm the individual concerned or be a clearly unwarranted invasion of his personal privacy:

- (1) Personnel and background records personal to any officer or employee of the Corporation, or other person, including his home address;
- (2) Medical histories and medical records concerning individuals, including applicants for licenses; or
- (3) Any other detailed record containing personal information identifiable with a particular person.

(b) The purpose of this section is to provide a proper balance between the protection of personal privacy and the preservation of the public's rights to Corporation information by authorizing the protection of information that, if released, might unjustifiably

invade an individual's personal privacy.

**§902.57 Investigatory files compiled for law enforcement purposes.**

(a) Files compiled by the Corporation for law enforcement purposes, including the enforcement of the regulations of the Corporation, are within the statutory exemption to the extent that production of such records would:

- (1) Interfere with enforcement proceedings;
- (2) Deprive a person of a right to a fair trial or an impartial adjudication;
- (3) Constitute an unwarranted invasion of personal privacy;
- (4) Disclose the identity of a confidential source and in the case of a record compiled by a criminal law enforcement authority in the courts of a criminal investigation, or by an agency conducting a lawful national security intelligence investigation, confidential information furnished only by the confidential source;
- (5) Disclose investigative techniques and procedures; or,
- (6) Endanger the life or physical safety of law enforcement personnel.

(b) The purpose of this section is to protect from disclosure the law enforcement files of the Corporation including files prepared in connection with related litigation and adjudicative proceedings. It includes the enforcement not only of criminal statutes but all kinds of laws.

**§902.58 Reports of financial institutions.**

Any material contained in or related to any examination, operating, or condition report prepared by, on behalf of, or for the use of, any agency responsible for the regulation or supervision of financial institutions is within the statutory exemption.

**§902.59 Geological and geophysical information.**

Any geological or geophysical information and data (including maps) concerning wells is within the statutory exemption.

### Subpart G—Time Limitations

#### § 902.60 Initial determination.

(a) An initial determination whether or not to release a record requested under subparts D and E of this part shall be made by the Public Information Offices within 10 workdays after the receipt of a request which complies with § 902.21. Failure of the requester to comply with those provisions may toll the running of the 10 day period until the request is identified as one being made under the Act. This time limit may be extended by up to 10 workdays in accordance with § 902.62.

(b) Upon making initial determination, the Administrative Officer shall immediately notify the person making the request as to its disposition. If the determination is made to release the requested record, the Administrative Officer shall make the record promptly available. If the determination is to deny the release of the requested record, the Public Information Officer shall immediately notify the requester of the denial and shall provide the following information.

(1) The reason for the determination, including a reference to the appropriate exemption provided in subpart F of this part;

(2) The right of the request or to appeal the determination as provided in subpart H of this part; and

(3) The name and position of each person responsible for the denial of the request.

[41 FR 43143, Sept. 30, 1976, as amended at 48 FR 17354, Apr. 22, 1983]

#### § 902.61 Final determination.

A determination with respect to any appeal made pursuant to subpart H of this part will be made within twenty work days after the date of receipt of the appeal. The time limit provided may be extended by up to 10 workdays in accordance with § 902.62.

#### § 902.62 Extension of time limits.

(a) In unusual circumstances, the time limits prescribed in §§ 902.60 and 902.61 may be extended by written notice to the person making the request. The notice shall set forth the reasons

for the extension and the date on which a determination is expected to be dispatched. Under no circumstances shall the notice specify a date that would result in an extension for more than 10 workdays.

(b) As used in this section, *unusual circumstances* means (but only to the extent reasonably necessary to the proper processing of the particular request):

(1) The need to search for, collect and appropriately examine a voluminous amount of separate and distinct records which are demanded in a single request;

(2) The need to search for and collect the requested records from field facilities or other establishments that are separate from the office processing the request; or

(3) The need for consultation, which shall be conducted with all practicable speed, with another agency having a substantial interest in the determination of the request or among two or more components of the agency having substantial subject matter interest therein.

(c) Any person having made a request for records under this part shall have exhausted his administrative remedies with respect to such request, if the Corporation fails to comply with the applicable time limitations set forth in this subject.

### Subpart H—Procedures for Administrative Appeal of Decisions Not To Disclose Records

#### § 902.70 General.

Within the time limitations of subpart G of this part, if the Administrative Officer makes a determination not to disclose a record requested under subparts D and E of this part, he shall furnish a written statement of the reasons for that determination to the person making the request. The statement shall indicate the name(s) and title(s) of each person responsible for the denial of the request, and the availability of an appeal with the Corporation. Any person whose request for a record has

## Pennsylvania Avenue Development Corporation

## § 902.82

been denied may submit a written appeal to the Corporation requesting reconsideration of the decision.

[41 FR 43143, Sept. 30, 1976, as amended at 48 FR 17354, Apr. 22, 1983]

### § 902.71 Forms for appeal.

Although no particular written form is prescribed for on appeal, the letter or similar written statement appealing a denial of a record shall contain a description of the record requested, the name and position of the official who denied the request, the reason(s) given for the denial, and other pertinent facts and statements deemed appropriate by the appellant. The Corporation may request additional details if the information submitted is insufficient to support an appeal.

### § 902.72 Time limitations on filing an appeal.

An appeal must be submitted in writing within thirty days from the date of receipt of the initial written denial and must contain the information requested in § 902.71.

### § 902.73 Where to appeal.

An appeal shall be addressed to the Chairman of the Board of Directors, Pennsylvania Avenue Development Corporation, 1331 Pennsylvania Avenue, NW., Suite 1220 North, Washington, DC 20004.

[41 FR 43143, Sept. 30, 1976, as amended at 50 FR 45824, Nov. 4, 1985]

### § 902.74 Agency decision.

(a) The Chairman shall have sole authority to act on an appeal, which seeks to reverse an initial decision denying disclosure of a record. He shall review each appeal and provide the appellant and other interested parties with a written notice of his decision. The decision of the Chairman as to the availability of the record is administratively final.

(b) If the decision of the Chairman sustains the refusal to disclose, the notice of decision shall set forth the reasons for the refusal, including the specific exemptions from disclosure under the Act that are the bases of the decision not to disclose. The notice shall further advise the appellant that judi-

cial review is available on complaint to the appropriate District Court of the United States, as provided in section 552(a)(4)(B) of title 5 U.S.C.

(c) As set out in § 902.61, the final decision on appeal shall be made within 20 workdays after the receipt of the appeal. An extension of this limitation is authorized as prescribed under § 902.62.

## Subpart I—Fees

### § 902.80 General.

(a) This subpart prescribes fees for services performed by the Corporation under subparts D and E of this part. This subpart shall only apply to the services described herein. The fees for the service listed reflect the actual cost of the work involved in compiling requested record and copying, if necessary.

(b) A fee shall not be charged for time spent in resolving legal or policy issues.

[41 FR 43143, Sept. 30, 1976, as amended at 52 FR 26677, July 16, 1987]

### § 902.81 Payment of fees.

The fees prescribed in this part may be paid in cash or by check, draft, or postal money order made payable to the Pennsylvania Avenue Development Corporation.

[52 FR 26677, July 16, 1987]

### § 902.82 Fee schedule.

(a) *Definitions.* For purposes of this section—

(1) A *commercial use request* is a request from or on behalf of one who seeks information for a use or purpose that furthers the commercial, trade, or profit interests of the requester or the person on whose behalf the request is made. In determining whether a requester properly belongs in this category, the Corporation will determine the use to which the requester will put the records sought. Where the Corporation has reasonable cause to doubt the use to which a requester will put the records sought, or where that use is not clear from the request itself, the Corporation will seek additional clarification before assigning the request to a specific category.

(2) *Direct costs* means those expenditures the Corporation actually incurs in searching for and duplicating (and in the case of commercial requesters, reviewing) records to respond to an FOIA request. Direct costs include, for example, the salary of the employee performing work (the basic rate of pay for the employee plus 16 percent of that rate to cover benefits) and the cost of operating duplicating machinery. Not included in direct costs are overhead expenses such as costs of space, and heating or lighting the facility in which the records are stored.

(3) *Duplication* means the process of making a copy of a record necessary to respond to an FOIA request. Such copies can take the form of paper copy, microform, audio-visual materials, or machine-readable documentation (e.g., magnetic tape or disk), among others. The copy provided must be in a form that is reasonably usable by requesters.

(4) *Educational institution* means a preschool, a public or private elementary or secondary school, an institution of graduate higher education, an institution of undergraduate higher education, an institution of professional education, and an institution of vocational education, which operates a program or programs of scholarly research.

(5) *Non-commercial scientific institution* means an institution that is not operated on a *commercial* basis, within the meaning of paragraph (a)(1) of this section and that is operated solely for the purpose of conducting scientific research, the results of which are not intended to promote any particular product or industry.

(6) *Representative of the new media* means any person actively gathering news for an entity that is organized and operated to publish or broadcast news to the public. The term *news* means information that is about current events or that would be of current interest to the public. Examples of new media entities include television or radio stations broadcasting to the public at large, and publishers of periodicals (but only in those instances when they can qualify as disseminators of *news*) who make their products available for purchase or subscription by

the general public. These examples are not intended to be all-inclusive. Moreover, as traditional methods of news delivery evolve (e.g., electronic dissemination of newspapers through telecommunications services), such alternative media would be included in this category. *Freelance* journalists may be regarded as working for a news organization if they can demonstrate a solid basis for expecting publication through that organization, even though not actually employed by it. A publication contract would be the clearest proof, but the Corporation may also look to the past publication record of a requester in making this determination.

(7) *Review* means the process of examining records located in response to a request that is for a commercial use (see paragraph (a)(1) of this section) to determine whether any portion of any record located is permitted to be withheld. It also includes processing any records for disclosure, e.g., doing all that is necessary to excise them and otherwise prepare them for release. Review does not include time spent resolving general legal or policy issues regarding the application of exemptions.

(8) *Search* includes all time spent looking for material that is responsive to a request, including page-by-page or line-by-line identification of material within records. A line-by-line search will not be conducted when merely duplicating an entire record would be the less expensive and quicker method of complying with the request. *Search* does not include *review* of material to determine whether the material is exempt from disclosure (see paragraph (a)(7) of this section). Searches may be done manually or by computer using existing programming.

(b) The following provisions shall apply with respect to services rendered to the public in processing requests for disclosure of the Corporation's records under this part:

(1) *Fee for duplication of records*: \$0.25 per page. When the Corporation estimates that duplication charges are likely to exceed \$25.00, it will notify the requester of the estimated amount of fees, unless the requester has indicated in advance his willingness to pay fees as high as those anticipated. The

Corporation will offer the requester the opportunity to confer with the Corporation's staff in order to reformulate the request to meet the requester's needs at a lower cost.

(2) *Search and review fees.* (i) Searches for records by clerical personnel: \$7.00 per hour, including the time spent searching for and copying any records.

(ii) Search for and review of records by professional and supervisory personnel: \$11.50 per hour spent searching for any record or reviewing any record to determine whether it may be disclosed, including time spent in copying any record.

(iii) Except for requests seeking records for a commercial use, the Corporation will provide the first 100 pages of duplication and the first two hours of search time without charge. The word *pages* means paper copies of a standard size, either 8½" by 11" or 14" by 14".

(3) *Duplication of architectural drawings, maps, and similar materials:* (per copy) \$10.00.

(4) *Reproduction of 35 mm slides:* (per copy) \$1.00.

(5) *Reproduction of enlarged, black and white photographs:* (per copy) \$10.00.

(6) *Reproduction of enlarged color photographs:* (per copy) \$17.00.

(7) *Certification and validation fee:* \$1.75 for each certification or validation of a copy of any record.

(8) *Categories of FOIA requesters and fees to be charged—*(i) *Commercial use requesters.* When the Corporation receives a request for records for commercial use, it will assess charges to recover the full direct costs of searching for, reviewing for release, and duplicating the records sought. Requesters must reasonably describe the records sought.

(ii) *Educational and non-commercial scientific institution requesters.* The Corporation shall provide copies of records to requesters in this category for the cost of reproduction alone, excluding charges for the first 100 pages. To be eligible for inclusion in this category, requesters must show that the request is being made as authorized by and under the auspices of a qualifying institution and that the records are not sought for a commercial use but are sought in furtherance of scholarly (if the request is from an educational institution) or sci-

entific (if the request is from a non-commercial scientific institution) research. Requesters must reasonably describe the records sought.

(iii) *Requesters who are representatives of the news media.* The Corporation shall provide documents to requesters in this category for the cost of reproduction alone, excluding charges for the first 100 pages. To be eligible for inclusion in this category, a requester must meet the criteria in the definition of *representative of the news media* in paragraph (a)(6) of this section, and his or her request must not be made for a commercial use. In reference to this class of requester, a request for records supporting the news dissemination function of the requester shall not be considered to be a request that is for a commercial use. Requestors must reasonably describe the records sought.

(iv) *All other requesters.* The Corporation will charge requesters who do not fit into any of the categories above fees which recover the full reasonable direct cost of searching for and reproducing records that are responsive to the request, except that the first 100 pages of reproduction and the first two hours of search time shall be furnished without charge. Requests from record subjects for records about themselves filed in the Corporation's systems of records will be treated under the fee provisions of the Privacy Act of 1974 which permit fees only for reproduction. Requesters must reasonably describe the records sought.

(9) *Interest.* In the event a requester fails to remit payment of fees charged for processing a request under this part within 30 days from the date such fees were billed, interest on such fees may be assessed beginning on the 31st day after the billing date at the rate prescribed in section 3717 of title 31 U.S.C., and will accrue from the date of the billing.

(10) *Unsuccessful searches.* Except as provided in paragraph (b)(8)(iv) of this section, the cost of searching for a requested record shall be charged even if the search fails to locate such record or it is determined that the record is exempt from disclosure.

(11) *Aggregating requests.* A requester must not file multiple requests at the same time, each seeking portions of a

## § 902.83

record or records, solely in order to avoid payment of fees. When the Corporation reasonably believes that a requester, or a group of requesters acting in concert, is attempting to break a request down into a series of requests for the purpose of evading the assessment of fees, the Corporation may aggregate any such requests and charge accordingly.

(12) *Advance payments.* The Corporation will not require a requester to make an advance payment, i.e., payment before work is commenced or continued on a request unless:

(i) The Corporation estimates or determines that allowable charges that a requester may be required to pay are likely to exceed \$250; or

(ii) If a requester has previously failed to make timely payments (i.e., within 30 days of billing date) of fees charged under this part, the requester may be required to pay the full amount owed plus any applicable interest accrued thereon or demonstrate that he has, in fact, paid the fee, and to make an advance payment of the full amount of the estimated fee before the Corporation begins to process a new request or a pending request from this requester.

(iii) With regard to any request coming within paragraphs (b)(12) (i) and (ii) of this section, the administrative time limits set forth in §§ 902.60, 902.61, and 902.62 of this part will begin to run only after the Corporation has received the requisite fee payments.

(iv) *Non-payment.* In the event of non-payment of billed charges for disclosure of records, the provisions of the Debt Collection Act of 1982 (Pub. L. 97-365), including disclosure to consumer credit reporting agencies and referral to collection agencies, where appropriate, may be utilized to obtain payment.

[52 FR 26677, July 16, 1987]

### § 902.83 Waiver or reduction of fees.

Fees otherwise chargeable in connection with a request for disclosure of a record shall be waived or reduced where:

(a) Disclosure of the information is in the public interest because it is likely to contribute significantly to public understanding of the operations or ac-

## 36 CFR Ch. IX (7-1-03 Edition)

tivities of the government and is not primarily in the commercial interest of the requester; or

(b) The costs of routine collection and processing of the fee are likely to equal or exceed the amount of the fee.

[52 FR 26679, July 16, 1987]

## PART 903—PRIVACY ACT

Sec.

903.1 Purpose and scope.

903.2 Definitions.

903.3 Procedures for notification of records pertaining to individuals.

903.4 Requests for access to records.

903.5 Response to request for access.

903.6 Appeal of initial denial of access.

903.7 Requests for amendment of record.

903.8 Review of request for amendment of record.

903.9 Appeal of initial adverse determination of request for amendment of record.

903.10 Disclosure of records to persons or agencies.

903.11 Routine uses of records maintained in the system of records.

903.12 Fees for furnishing and reproducing records.

903.13 Penalties.

AUTHORITY: 5 U.S.C. 552a; 40 U.S.C. 870.

SOURCE: 42 FR 5973, Feb. 1, 1977, unless otherwise noted.

### § 903.1 Purpose and scope.

The purpose of this part is to enable the Pennsylvania Avenue Development Corporation to implement the Privacy Act of 1974, and in particular the provisions of 5 U.S.C. 552a, as added by the Act. The Act was designed to insure that personal information about individuals collected by Federal agencies be limited to that which is legally authorized and necessary, and that the information is maintained in a manner which precludes unwarranted intrusions upon individual privacy. The regulations in this part establish, and make public, procedures whereby an individual can:

(a) Request notification of whether or not the Corporation maintains or has disclosed a record pertaining to him or her,

(b) Request access to such a record or an accounting of its disclosure,

(c) Request that the record be amended, and

## Pennsylvania Avenue Development Corporation

## § 903.4

(d) Appeal any initial adverse determination of a request to amend a record.

### § 903.2 Definitions.

As used in this part:

(a) *Agency* means agency as defined in 5 U.S.C. 552(e).

(b) *Corporation* means the Pennsylvania Avenue Development Corporation.

(c) *Workday* shall be a day excluding a Saturday, Sunday or legal holiday.

(d) *Individual* means a citizen of the United States or an alien lawfully admitted for permanent residence.

(e) *Maintain* includes maintain, collect, use, or disseminate.

(f) *Record* means any items, collection, or grouping of information about an individual that is maintained by an agency, including, but not limited to, his or her education, financial transactions, medical history, and criminal or employment history and that contains his or her name, or the identifying number, symbol or other identifying particular assigned to the individual, such as a finger or voice print or a photograph.

(g) The term *system of records* means a group of records under the control of an agency from which information is retrieved by the name of the individual or by some identifying number, symbol, or other identifying particular assigned to the individual.

(h) The term *statistical record* means a record in a system of records maintained for statistical research or reporting purposes only and not used in whole or in part in making any determination about an identifiable individual except as provided by section 8 of title 13 U.S.C.

(i) The term *routine use* means, with respect to the disclosure of a record, the use of such record for a purpose which is compatible with the purpose for which it was collected.

### § 903.3 Procedures for notification of records pertaining to individuals.

(a) An individual making a written or oral request under the Privacy Act (5 U.S.C. 522a) shall be informed of any Corporation systems of records which pertain to the individual, if the request contains a reasonable identification of

the appropriate systems of records as described in the notice published in the FEDERAL REGISTER.

(b) Requests may be made in person between the hours of 9:00 a.m. and 5:00 p.m. Monday through Friday, (except legal holidays). The request should be addressed to the Privacy Protection Officer, Pennsylvania Avenue Development Corporation, 1331 Pennsylvania Avenue, NW., Suite 1220 North, Washington, DC 20004. The Privacy Protection Officer of the Corporation will require adequate personal identification before processing the request. If a request is made in writing it must be under the signature of the requesting individual and include the individual's address, date of birth, and an additional proof of identification, such as a photocopy of a driver's license or similar document bearing the individual's signature. A notarized, signed statement is acceptable to verify the identity of the individual involved without additional proof.

[42 FR 5973, Feb. 1, 1977, as amended at 50 FR 45824, Nov. 4, 1985]

### § 903.4 Requests for access to records.

(a) Except as otherwise provided by law or regulation, an individual, upon request made in person or delivered in writing may gain access to his or her record or to any information pertaining to him or her which is contained in a system of records maintained by the Corporation, and to review the record and have a copy made of all or any portion thereof in a form comprehensible to him or her. An individual seeking access to a Corporation record may be accompanied by a person of his or her choosing. However, the Corporation will require a written statement from the individual authorizing discussion of his or her record in the accompanying person's presence.

(b) A request under paragraph (a) of this section shall be directed to the Privacy Protection Officer at the place, times and in the manner prescribed in § 903.3(a) and (b). The request should include the following information:

- (1) The name of the individual;
- (2) If made in writing, the information required under § 903.3(b);

### § 903.5

(3) A description of system or systems of records which contain the record to which access is requested;

(4) The approximate dates covered by the record; and,

(5) A suggested date and time when the individual would like to view the record.

(c) Requests which do not contain information sufficient to identify the record requested will be returned promptly to the requester, with a notice indicating that information is lacking. Individuals making requests in person will be informed of any deficiency in the specification of records or identification at the time that the request is made. The Privacy Protection Officer of the Corporation will require adequate personal identification before processing a request made in person.

#### **§ 903.5 Response to request for access.**

(a) Within 10 days of receipt of a request made under § 903.4 the Privacy Protection Officer shall determine whether access to the record is available under the Privacy Act and shall notify the requesting individual in person or in writing of that determination.

(b) Notices granting access shall inform the individual when and where the requested record may be seen, how copies may be obtained, and of any anticipated fees or charges which may be incurred under § 903.11. Access shall be provided within 30 days of receipt of the request unless the Corporation, for good cause shown, is unable to provide prompt access, in which case the individual shall be informed in writing within the 30 days as to the cause for delay and when it is anticipated that access will be granted.

(c) Notices denying access shall state the reasons for the denial, and advise the individual that the decision may be appealed in accordance with the procedures set forth in § 903.6.

#### **§ 903.6 Appeal of initial denial of access.**

(a) After receiving notification of an initial denial of access to a record, an individual may request a review and reconsideration of the request by the Executive Director of the Corporation, or

### 36 CFR Ch. IX (7-1-03 Edition)

an officer of the Corporation designated by him, but other than the Privacy Protection Officer. Appeals for review shall be in writing, addressed to the Executive Director, Pennsylvania Avenue Development Corporation, 1331 Pennsylvania Avenue, NW., Suite 1220 North, Washington, DC 20004. The appeal shall identify the record as in the original request, shall indicate the date of the original request and the date of the initial denial, and shall indicate the expressed basis for the denial.

(b) Not later than 30 days after receipt of an appeal, the Executive Director, or an officer of the Corporation designated by him, will complete review of the appeal and the initial denial and either:

(1) Determine that the appeal should be granted, and notify the individual in writing to that effect; or,

(2) Determine that the appeal should be denied because the information requested is exempt from disclosure. If the reviewing official denies the appeal, he or she shall advise the individual in writing of the decision and the reasons for reaching it, and that the denial of the appeal is a final agency action entitling the individual to seek judicial review in the appropriate district court of the United States as provided in 5 U.S.C. 552a(g).

[42 FR 5973, Feb. 1, 1977, as amended at 50 FR 45824, Nov. 4, 1985]

#### **§ 903.7 Requests for amendment of record.**

(a) An individual may request amendment of a Corporation record pertaining to him or to her, if the individual believes that the record contains information which is not accurate, relevant, timely, or complete. The request shall be in writing, whether presented in person or by mail, shall state with specificity the record sought to be amended, and shall propose wording of the correction or amendment sought. The request shall be directed to the Privacy Protection Officer at the place, times, and in the manner specified in § 903.3 (a) and (b). Assistance in preparing a request to amend a record,



or to appeal an initial adverse determination under §903.3(a), may be obtained from the Privacy Officer, Pennsylvania Avenue Development Corporation, 1331 Pennsylvania Avenue, NW., Suite 1220 North, Washington, DC 20004.

(b) Not later than 10 days after the date of receipt of a request the Privacy Protection Officer will acknowledge it in writing. The acknowledgement will clearly describe the request, and if a determination has not already been made, will advise the individual when he or she may expect to be advised of action taken on the request. For requests presented in person, written acknowledgement will be provided at the time when the request is presented. No separate acknowledgement of receipt will be issued if the request can be reviewed and the individual advised of the results of the review within the 10 day period.

[42 FR 5973, Feb. 1, 1977, as amended at 50 FR 45824, Nov. 4, 1985]

**§ 903.8 Review of request for amendment of record.**

(a) Upon receipt of a request for amendment of a record the Privacy Protection Officer will promptly review the record and: Either:

(1) Amend any portion thereof which the individual believes is not accurate, relevant, timely, or complete; or

(2) Inform the individual of refusal to amend the record in accordance with the request. In reviewing a record pursuant to a request to amend it, the Corporation will assess the accuracy, relevance, timeliness and completeness of the record in terms of the criteria established in 5 U.S.C. 522a(e)(5). In reviewing a record in response to a request to amend it by deleting information, the Corporation will ascertain whether or not the information is relevant and necessary to accomplish a purpose of the Corporation required to be accomplished by statute or by executive order of the President, as prescribed by 5 U.S.C. 522a(e)(1).

(b) The Corporation shall take the action specified in paragraph (a) of this section within 30 days of receipt of a request for amendment of a record, unless unusual circumstances preclude completion of the action within that time. If the expected completion date

for the action, as indicated in the acknowledgement provided pursuant to §903.5 cannot be met, the individual shall be advised of the delay and of a revised date when action is expected to be completed. If necessary for an accurate review of the record, the Corporation will seek, and the individual will supply, additional information in support of his or her request for amending the record.

(c) If the Corporation agrees with all or any portion of an individual's request to amend a record, the Corporation will so advise the individual in writing, and amend the record to the extent agreed to by the Corporation. Where an accounting of disclosures has been kept, the Corporation will advise all previous recipients of the record of the fact that the amendment was made and the substance of the amendment.

(d) If the Corporation disagrees with all or any portion of an individual's request to amend a record, the Corporation shall:

(1) Advise the individual of its adverse determination and the reasons therefor, including the criteria used by the Corporation in conducting the review;

(2) Inform the individual that he or she may request a review of the adverse determination by the Executive Director of the Corporation, or by an officer of the Corporation designated by the Executive Director; and,

(3) Advise the individual of the procedures for requesting such a review including the name and address of the official to whom the request should be directed.

(e) If the Corporation is apprised by another agency of any corrections or other amendments made to a record contained in the Corporation's system of records, the Corporation will promptly amend its record and advise in writing all previous recipients of the record of the fact that the amendment was made and the substance of the amendment.

**§ 903.9 Appeal of initial adverse determination of request for amendment of record.**

(a) After receipt by an individual of notice of an adverse determination by

**§ 903.10**

**36 CFR Ch. IX (7-1-03 Edition)**

the Privacy Protection Officer concerning a request to amend a record, the individual may, within 60 working days after the date of receipt of the notice, appeal the determination by seeking a review by the Executive Director of the Corporation, or by an officer of the Corporation designated by him. The appeal shall be in writing, mailed or delivered to the Executive Director, Pennsylvania Avenue Development Corporation, 1331 Pennsylvania Avenue, NW, Suite 1220 North, Washington, DC 20004. The appeal shall identify the record in the same manner as it was identified in the original request, shall indicate the dates of the original request and of the adverse determination and shall indicate the expressed basis for that determination. In addition, the appeal shall state briefly the reasons why the adverse determination should be reversed.

(b) Not later than 30 days after receipt of an appeal, the Executive Director, or an officer of the Corporation designated by him, will complete a review of the appeal and the initial determination, and either: (1) Determine that the appeal should be granted, take the appropriate action with respect to the record in question, and notify the individual accordingly; or, (2) determine that the appeal should be denied.

(c) The reviewing official may, at his or her option, request from the individual such additional information as is deemed necessary to properly conduct the review. If additional time is required, the Executive Director may, for good cause shown, extend the period for action beyond the 30 days specified above. The individual will then be informed in writing of the delay and the reasons therefor, and of the approximate date on which action is expected to be completed.

(d) If the reviewing official denies the appeal, he or she shall advise the individual in writing:

(1) Of the decision and the reasons for reaching it;

(2) That the denial of the appeal is a final agency action entitling the individual to seek judicial review in the appropriate district court of the United States, as provided in 5 U.S.C. 552a(g); and,

(3) That the individual may file with the Corporation a concise statement setting forth the reasons for his or her disagreement with the refusal of the Corporation to amend the record in question.

(e) Any individual having received notices of a denial of an appeal to amend a record may file a statement of disagreement with the Executive Director not later than 60 working days from the date of receipt of the notice. Such statements shall ordinarily not exceed one page in length, and the Corporation reserves the right to reject statements of excessive length. Upon receipt of a proper and timely statement of disagreement, the Corporation will clearly annotate the record in question to indicate the portion of the record which is in dispute. In any subsequent disclosure containing information about which the individual has filed a statement of disagreement, the Corporation will provide a copy of the statement together with the record to which it pertains. In addition, prior recipients of the disputed record will be provided with a copy of statements of disagreement to the extent that an accounting of disclosures was maintained. If the Corporation deems it appropriate, it may also include in any disclosure its own concise statement of the reasons for not making the amendments requested.

[42 FR 5973, Feb. 1, 1977, as amended at 50 FR 45824, Nov. 4, 1985]

**§ 903.10 Disclosure of records to persons or agencies.**

(a) The Corporation will not disclose any record which is contained in a system of records, by any means of communication to any person or to another agency except:

(1) Pursuant to a written request by, or with the prior written consent of, the individual to whom the record pertains;

(2) To those officers and employees of the Corporation who have a need for the record in the performance of their duties;

(3) When required under 5 U.S.C. 522 (The Freedom of Information Act); or

(4) Pursuant to the conditions of disclosure contained in 5 U.S.C. 552a(b)(3) through 5 U.S.C. 522a(b)(11).

(b) The Privacy Protection Officer of the Corporation shall keep an accounting of each disclosure made pursuant to paragraph (a)(4) of this section, in accordance with 5 U.S.C. 552a(c). Except for disclosures made pursuant to 5 U.S.C. 552a(b)(7), the Privacy Protection Officer shall make the accounting kept under this paragraph available to an individual to whom the record pertains, upon his or her request. An individual requesting an accounting of disclosures should do so at the place, times and in the manner specified in §903.3 (a) and (b).

**§ 903.11 Routine uses of records maintained in the system of records.**

(a) It shall be a routine use of the records in this system of records to disclose them to the Department of Justice when:

- (1) The Corporation, or any component thereof; or
- (2) Any employee of the Corporation in his or her official capacity; or
- (3) Any employee of the Corporation in his or her individual capacity where the Department of Justice has agreed to represent the employee; or
- (4) The United States, where the Corporation determines that litigation is likely to affect the Corporation or any of its components, is a party to litigation or an interest in such litigation, and the use of such records by the Department of Justice is deemed by the Corporation to be relevant and necessary to the litigation, provided, however, that in each case, the Corporation determines that disclosure of the records to the Department of Justice is a use of the information contained in the records that is compatible with the purpose for which the records were collected.

(b) It shall be a routine use of records maintained by the Corporation to disclose them in a proceeding before a court or adjudicative body before which the Corporation is authorized to appear, when:

- (1) The Corporation, or any component thereof; or
- (2) Any employee of the Corporation is his or her individual capacity;
- (3) Any employee of the agency in his or her individual capacity where the

Department of Justice has agreed to represent the employee; or

(4) The United States, where the Corporation determines that litigation is likely to affect the Corporation or any of its components is a party to litigation or has an interest in such litigation and the Corporation determines that use of such records is relevant and necessary to the litigation, provided, however, that, in each case, the Corporation determines that disclosure of the records to the Department of Justice is a use of the information contained in the records that is compatible with the purpose for which the records were collected.

[52 FR 34384, Sept. 11, 1987; 52 FR 39224, Oct. 21, 1987]

**§ 903.12 Fees for furnishing and reproducing records.**

(a) Individuals will not be charged a fee for:

- (1) The search and review of the record;
- (2) Any copies of the record produced as a necessary part of the process of making the record available for access;
- (3) Any copies of the requested record when it has been determined that access can only be accomplished by providing a copy of the record through the mail. The Privacy Protection Officer may provide additional copies of any record without charge when it is determined that it is in the interest of the Government to do so.

(b) Except as provided in paragraph (a) of this section, fees will be charged for the duplication of records at a rate of 10¢ per page. If it is anticipated that the total fee chargeable to an individual under this subpart will exceed \$25, the Corporation shall promptly notify the requester of the anticipated cost. An advance deposit equal to 50% of the anticipated total fee will be required unless waived by the Privacy Protection Officer. In notifying the requester of the anticipated fee, the Privacy Protection Officer shall extend an offer to the requester to consult so that the request might be reformulated in a manner which will reduce the fee, yet still meet the needs of the requester.

## § 903.13

(c) Fees must be paid in full prior to delivery of the requested copies. Remittances may be in the form of cash, personal check, bank draft or a postal money order. Remittances, other than cash shall be made payable to the Treasurer of the United States.

[42 FR 5973, Feb. 1, 1977. Redesignated at 52 FR 34384, Sept. 11, 1987; 52 FR 39224, Oct. 21, 1987]

### § 903.13 Penalties.

The provision of 5 U.S.C. 552a(i), as added by section 3 of the Privacy Act, make it a misdemeanor subject to a maximum fine of \$5,000, to knowingly and willfully request or obtain any record concerning an individual from an agency under false pretenses. Similar penalties attach for violations by agency officers and employees of the Privacy Act or regulations established thereunder.

[42 FR 5973, Feb. 1, 1977. Redesignated at 52 FR 34384, Sept. 11, 1987; 52 FR 39224, Oct. 21, 1987]

## PART 904—UNIFORM RELOCATION ASSISTANCE AND REAL PROPERTY ACQUISITION FOR FEDERAL AND FEDERALLY ASSISTED PROGRAMS

AUTHORITY: Sec. 213, Uniform Relocation Assistance and Real Property Acquisition Policies Act of 1970, Pub. L. 91-646, 84 Stat. 1894 (42 U.S.C. 4601) as amended by the Surface Transportation and Uniform Relocation Assistance Act of 1987, title IV of Pub. L. 100-17, 101 Stat. 246-256 (42 U.S.C. 4601 *note*).

### § 904.1 Uniform relocation assistance and real property acquisition.

Regulations and procedures for complying with the Uniform Relocation Assistance and Real Property Acquisition Policies Act of 1970 (Pub. L. 91-646, 84 Stat. 1894, 42 U.S.C. 4601), as amended by the Surface Transportation and Uniform Relocation Assistance Act of 1987 (title IV of Pub. L. 100-17, 101 Stat. 246-255, 42 U.S.C. 4601 *note*) are set forth in 49 CFR part 24.

[52 FR 48022, Dec. 17, 1987 and 54 FR 8912, Mar. 2, 1989]

## 36 CFR Ch. IX (7-1-03 Edition)

## PART 905—STANDARDS OF CONDUCT

### Subpart A—General Provisions

- Sec.
- 905.735-101 Principles and purpose.
  - 905.735-102 Adoption of regulations.
  - 905.735-103 Definitions.
  - 905.735-104 Applicability.
  - 905.735-105 Designation of counselor.
  - 905.735-106 Notification to employees and special Government employees.
  - 905.735-107 Review of statements of employment and financial interests.
  - 905.735-108 Remedial and disciplinary action.

### Subpart B—Conduct and Responsibilities of Employees

- 905.735-201 General standards of conduct.
- 905.735-202 Gifts, entertainment, and favors.
- 905.735-203 Outside employment and other activity.
- 905.735-204 Disclosure of information.
- 905.735-205 Purchase of Government-owned property.

### Subpart C—Conduct and Responsibilities of Special Government Employees

- 905.735-301 General standards of conduct.

### Subpart D—Special Standards Applicable to Certain Board Members

- 905.735-401 Standards.
- 905.735-402 Advice and determination.

### Subpart E—Statements of Employment and Financial Interests

- 905.735-501 Form and content of statements.
- 905.735-502 Statements of employment and financial interests by employees.
- 905.735-503 Statements of employment and financial interests by special Government employees.
- 905.735-504 Procedures for obtaining statements.
- 905.735-505 Confidentiality of statements.

### Subpart F—Conduct and Responsibilities of Former Employees—Enforcement

- 905.737-101 Applicable provisions of law.
- 905.737-102 Enforcement proceedings.

AUTHORITY: 40 U.S.C. 875, unless otherwise noted.

SOURCE: 43 FR 60902, Dec. 29, 1978, unless otherwise noted.

**Subpart A—General Provisions**

**§ 905.735-101 Principles and purpose.**

In order to assure that the business of the Pennsylvania Avenue Development Corporation is conducted effectively, objectively, and without improper influence or appearance thereof, all employees and special Government employees must observe unquestionable standards of integrity and conduct. Employees and special Government employees shall not engage in criminal, infamous, dishonest, immoral, or disgraceful conduct or other conduct prejudicial to the Government. All employees and special Government employees must avoid conflicts of private interest with their public duties and responsibilities. They must consider the propriety of any action in relation to general ethical standards of the highest order, so that public confidence in the integrity of the Government will not be impaired. Certain standards are set by law. Others are set by regulation and by policy. This part incorporates by reference applicable general standards of conduct and prescribes additional necessary elements. Taken together, this part constitutes the Corporation's regulations on this subject. Failure to observe any of the regulations in this part is cause for remedial action.

**§ 905.735-102 Adoption of regulations.**

Under the authority of 5 CFR 735.104(f), the Corporation adopts the following sections of the Civil Service Commission regulations on "Employee Responsibilities and Conduct" found in part 735 of title 5, Code of Federal Regulations: §§ 735.202 (a), (d), (e), (f) through 735.210; 735.302; 735.303(a); 735.304; 735.305(a); 735.306; 735.404 through 735.411; and 735.412 (b) and (d).

[43 FR 60902, Dec. 29, 1978, as amended at 45 FR 15927, Mar. 12, 1980]

**§ 905.735-103 Definitions.**

As used in this part:

(a) *Board Member* means any member of the Board of Directors of the Pennsylvania Avenue Development Corporation, appointed or serving under section 3, Pub. L. 92-578, 86 Stat. 1267 (40 U.S.C. 872).

(b) *Chairman* means the Chairman of the Board of Directors and President of the Corporation.

(c) *Conflict* means the subordination of public responsibilities to private interests, and includes the appearance of such subordination.

(d) *Consultant* means an individual who serves as an advisor to an officer or division of the Corporation, as distinguished from an officer or employee who carries out the agency's duties and responsibilities. He gives his views or opinions on problems or questions presented him by the Corporation, but he neither performs nor supervises performance of operating functions. Ordinarily, he is expert in the field in which he advises, but he need not be a specialist. His expertness may lie in his possession of a high order of broad administrative, professional, or technical experience indicating that his ability and knowledge make his advice distinctively valuable to the agency. (Chapter 304, Federal Personnel Manual).

(e) *Corporation* means the Pennsylvania Avenue Development Corporation, created by the Pennsylvania Avenue Development Corporation Act of 1972, Pub. L. 92-578, 86 Stat. 1266 (40 U.S.C. 871).

(f) *Employee* means an officer or employee of the Corporation, but does not include a special Government employee as defined herein. The term includes those Board Members who are determined to be officers or employees of the executive or legislative branches of the United States or of the District of Columbia. The term does not include elected officials.

(g) *Executive order* means Executive Order 11222 of May 8, 1965.

(h) *Expert* means a person with excellent qualifications and a high degree of attainment in a professional, scientific, technical, or other field. His knowledge and mastery of the principles, practices, problems, methods, and techniques of his field of activity, or of a specialized area in the field, are clearly superior to those usually possessed by ordinarily competent individuals in that activity. His attainment is such that he usually is regarded as an authority or as a practitioner of unusual competence and skill by other

**§ 905.735-104**

persons in the profession, occupation, or activity. (Chapter 304, Federal Personnel Manual.)

(i) *Head of the agency* means the Chairman.

(j) *Person* means an individual, a corporation, a company, an association, a firm, a partnership, a society, a joint stock company, or any other institution or organization.

(k) *Special Government Employee* means an officer or employee of the Corporation who is retained, designated, appointed or employed to perform, with or without compensation, for not more than 130 days during any period of 365 consecutive days, temporary duties either on a full time or intermittent basis (18 U.S.C. 202(a)). The term includes those Board Members who are appointed from private life and required to file a statement of financial interests with the Chairman of the Civil Service Commission pursuant to part IV of the Executive order, or who are determined to be special government employees of the executive or legislative branches of the United States or the District of Columbia.

**§ 905.735-104 Applicability.**

This part applies to each employee and to each special Government employee of the Corporation as defined herein and supplements the Executive order and part 735 of title 5, Code of Federal Regulations, promulgated by the Civil Service Commission on employee responsibilities and conduct.

**§ 905.735-105 Designation of counselor.**

In accordance with 5 CFR 735.105(a), the General Counsel of the Corporation is designated to be Ethics Counselor and shall serve as the Corporation's liaison with the Civil Service Commission for matters covered in this part.

**§ 905.735-106 Notification to employees and special Government employees.**

(a) At the time these regulations are published, or amended, and not less often than once annually thereafter, the Corporation shall furnish each employee and special Government employees with a copy of the regulations. The Administrative Officer shall insure that each newly hired employee and special Government employee is given

**36 CFR Ch. IX (7-1-03 Edition)**

a copy of these regulations prior to or at the time of entry on duty.

(b) All employees and special Government employees will be advised by the Corporation of the availability of counseling regarding the provisions of this part.

**§ 905.735-107 Review of statements of employment and financial interests.**

The Ethics Counselor of the Corporation shall review each statement of employment and financial interests submitted under § 905.735-402 or § 905.735-403, except his own and those statements of special Government employees who file with the Chairman of the Civil Service Commission. When review discloses a conflict between the interests of an employee or special Government employee of the Corporation and the performance of his services for the Corporation, the Ethics Counselor shall bring the conflict to the attention of the employee or special Government employee, grant the individual an opportunity to explain the conflict, and attempt to resolve it. If the conflict cannot be resolved, the Ethics Counselor shall forward a written report on the conflict to the Chairman, recommending appropriate action. The Chairman shall review the report, solicit an explanation from the individual, and seek resolution of the conflict.

**§ 905.735-108 Remedial and disciplinary action.**

(a) In addition to any penalties prescribed by law, the Chairman, after review and consideration of any explanation given by an employee or special Government employee concerning a conflict of interest, may institute appropriate remedial action to resolve or otherwise eliminate the conflict. Appropriate remedial action may include, but is not limited to:

- (1) Divestment by the employee or the special Government employee of the conflicting interest;
- (2) Disqualification of the individual from a particular assignment;
- (3) Changes in the assigned duties of the individual; or
- (4) Disciplinary action.

(b) Where the situation warrants some form of disciplinary action, the

Chairman may choose from a wide range including a warning or reprimand, suspension, reduction in grade or pay, or termination of employment. The disciplinary action selected should reflect the character and degree of the offense which demands such action and should be reasonable in light of that offense.

(c) Remedial action, whether disciplinary or otherwise, shall be effected in accordance with applicable laws, Executive orders, and regulations.

**Subpart B—Conduct and Responsibilities of Employees**

**§ 905.735–201 General standards of conduct.**

(a) All employees shall conduct themselves on the job so as to efficiently discharge the work of the Corporation. Courtesy, consideration, and promptness are to be observed in dealing with the public, Congress, and other governmental agencies.

(b) All employees shall conduct themselves off the job so as not to reflect adversely upon the Corporation or the Federal service.

(c) Employee conduct shall exemplify the highest standards of integrity. Employees shall avoid any action, whether or not specifically prohibited by this part, which might result in, or create the appearance of:

- (1) Using public office for private gain;
- (2) Giving preferential treatment to any person;
- (3) Impeding Government efficiency or economy;
- (4) Losing complete independence or impartiality;
- (5) Making a Government decision outside official channels; or
- (6) Affecting adversely the confidence of the public in the integrity of the Government.

**§ 905.735–202 Gifts, entertainment, and favors.**

Pursuant to paragraph (b) of 5 CFR 735.202, the following exceptions to the restriction of paragraph (a) of that section are authorized. Employees may:

(a) Accept gifts and other things of value under circumstances which arise from an obvious family or personal re-

lationship(s) (such as between the parents, children, or spouse of the employee and the employee), when the circumstances make it clear that it is those relationships rather than the business of the persons concerned which are the motivating factors;

(b) Accept food and refreshments of nominal value on infrequent occasions in the ordinary course of a luncheon, dinner, or other meeting, or on an inspection tour where an employee may properly be in attendance;

(c) Accept loans from banks or other financial institutions on customary terms to finance proper and usual activities of employees, such as home purchase;

(d) Accept unsolicited advertising or promotional materials, such as pens, pencils, note pads, calendars and other items of nominal intrinsic value;

(e) Participating without payment in privately funded activities in the Washington metropolitan area if: (1) An invitation is addressed to the Chairman or Executive Director of the Corporation and approved by either of them; (2) no provision for individual payment is readily available; and (3) the activities are limited to ceremonies of interest to both the local community and the Corporation (such as ground breakings or openings), or are sponsored or encouraged by the Federal or District Government as a matter of policy; and,

(f) Participate in widely attended lunches, dinners, and similar gatherings sponsored by industrial, commercial, technical and professional associations, or groups, for discussion of matters of interest both to the Corporation and the public. Participation by an employee at the host's expense is appropriate if the host is an association or group and not an individual.

**§ 905.735–203 Outside employment and other activity.**

As provided in 5 CFR 735.203, an employee of the Corporation may engage in outside employment or other outside activity not incompatible with the full and proper discharge of the duties and responsibilities of his Government employment. An employee who proposes to engage in outside employment shall

**§ 905.735-204**

report that fact in writing to his supervisor prior to undertaking such employment.

**§ 905.735-204 Disclosure of information.**

(a) Every employee who is involved in the development, maintenance or use of Corporation records containing information about individuals shall familiarize himself with the requirements and penalties of the Privacy Act of 1974 (5 U.S.C. 552a) and Corporation regulations (36 CFR part 903) promulgated thereunder concerning the utilization of and access to such records.

(b) Every employee is directed to cooperate to the fullest extent possible in discharging the requirement of the Freedom of Information Act (5 U.S.C. 522) and Corporation regulations promulgated thereunder (36 CFR part 902). Every effort should be made to furnish service with reasonable promptness to persons who seek access to Corporation records and information.

**§ 905.735-205 Purchase of Government-owned property.**

Employees of the Corporation and members of their immediate families may purchase Government-owned personal property when it is offered for sale by the General Services Administration or any Federal agency other than the Corporation (41 CFR 101-45.302).

**Subpart C—Conduct and Responsibilities of Special Government Employees**

**§ 905.735-301 General standards of conduct.**

(a) Special Government employees of the Corporation shall adhere to applicable regulations adopted under § 904.735-102, except 5 CFR 735.203(b). In addition, the standards of conduct set forth in §§ 905.735-201, 905.735-204, and 905.735-205 shall apply to special Government employees.

(b) Special Government employees of the Corporation may teach, lecture, or write consistent with the provisions of 5 CFR 735.203(c).

(c) Pursuant to 5 CFR 735.305(b), the provisions concerning gifts, entertainment, and favors set forth in § 905.735-

**36 CFR Ch. IX (7-1-03 Edition)**

202 are hereby made applicable to special Government employees.

**Subpart D—Special Standards Applicable to Certain Board Members**

**§ 905.735-401 Standards.**

Section 3(c)(8) of the Pennsylvania Avenue Development Corporation Act of 1972, Pub. L. 92-578, 86 Stat. 1267 (40 U.S.C. 872(c)(8)) specifies that the eight members appointed to the Board by the President from private life, at least four of whom shall be residents of the District of Columbia, "shall have knowledge and experience in one or more fields of history, architecture, city planning, retailing, real estate, construction or government." As a result of these prerequisites for appointment of a private member to the Board of Directors, conflicts could arise for these Board Members as the Corporation proceeds with various development activities. Accordingly, Board Members should perform their responsibilities for the operation and management of the Corporation consistent with these regulations, and other applicable Federal laws and regulations, and consistent with the highest level of fiduciary responsibility.

**§ 905.735-402 Advice and determination.**

The Corporation's Ethics Counselor is readily available for consultation when a Board Member seeks advice as to the appropriateness of his actions in light of this part, the Executive order, or title 18 U.S.C., chapter 11. A Board Member has an affirmative duty to advise the Ethics Counselor of any potential conflict of interest which may arise with the individual's participation in any particular matter before the Corporation. If advised to do so, the Board Member should submit to the Chairman for determination the question of whether or not the conflict will disqualify the Board Member from participating in the action to be taken by the Corporation. Under the authority delegated to the Chairman pursuant to 18 U.S.C. 208(b), the Chairman may find that the Board Member need not be disqualified from participating in the particular matter, if:



(a) The Board Member makes a full disclosure of the financial interest; and

(b) The Chairman furnishes him with a written determination in advance of the action that the interest is not so substantial as to be deemed likely to affect the integrity of the services which the Government may expect from the Board Member. Requests for similar determinations for conflicts posed by the financial interests of the Chairman himself shall be submitted to the Chairman of the Civil Service Commission.

opment Corporation, 1331 Pennsylvania Avenue, NW., Suite 1220 North, Washington, DC 20004. The General Counsel, as Ethics Counselor, shall submit his statement directly to the Chairman for review.

(c) An employee who believes that his position has been improperly included in this section as one requiring the submission of a statement of employment and financial interests may obtain a review of this determination upon a written request to the Chairman.

[43 FR 60902, Dec. 29, 1978, as amended at 50 FR 45824, Nov. 4, 1985]

**Subpart E—Statements of Employment and Financial Interests**

**§ 905.735-501 Form and content of statements.**

Statements of employment and financial interests required to be submitted under this subpart by employees and special Government employees shall contain the information required in the formats prescribed by the Civil Service Commission in the Federal Personnel Manual.

**§ 905.735-502 Statements of employment and financial interests by employees.**

(a) Employees of the Corporation in the following named positions shall prepare and submit statements of employment and financial interests:

- (1) Executive Director;
- (2) Assistant Director Legal—General Counsel;
- (3) Assistant Director/Finance;
- (4) Development Director;
- (5) Secretary of the Corporation Administrative Officer;
- (6) Construction Manager;
- (7) Senior Architect/Planner;
- (8) Chief, Real Estate Operations;
- (9) Any Contracting Officer of the Corporation; and
- (10) Any employee classified as a GS-13 or above whose duties and responsibilities are such that the ethics counselor determines a statement should be filed.

(b) Each statement of employment and financial interests required by this section, except that of the General Counsel, shall be submitted to the Ethics Counselor, Office of the General Counsel, Pennsylvania Avenue Devel-

**§ 905.735-503 Statements of employment and financial interests by special Government employees.**

All special Government employees shall submit a statement of employment and financial interest prior to beginning employment or service with the Corporation. Each statement shall be submitted to the Ethics Counselor, Office of the General Counsel, Pennsylvania Avenue Development Corporation, 1331 Pennsylvania Avenue, NW., Suite 1220 North, Washington, D.C. 20004, except that the statements of Board Members appointed from private life shall be filed with the U.S. Civil Service Commission.

[43 FR 60902, Dec. 29, 1978, as amended at 50 FR 45824, Nov. 4, 1985]

**§ 905.735-504 Procedures for obtaining statements.**

(a) Upon the adopting of the regulations of this part, the Ethics Counselor shall deliver to the incumbent of each position named in § 905.735-402 and to each special Government employee, two copies of the appropriate form for filing a statement of employment and financial interests. An enclosure with the forms shall advise that:

- (1) The original of the completed form must be returned in a sealed envelope, marked "Personal—In Confidence," to the Ethics Counselor within the time specified by the Ethics Counselor;
- (2) The services of the ethics counselor are available to advise and assist in preparation of the statement;
- (3) Any additions or deletions to the information furnished must be reported

**§ 905.735-505**

in a supplementary statement at the end of the calendar quarter in which the change occurs; or in the case of a special Government employee, at the time the change occurs; and

(4) No later than June 30 of each year, all special Government employees and employees required to file under § 905.735-402(a) shall file an annual supplementary statement to update the information previously filed.

(b) The Administrative Officer shall be responsible for assuring that a completed statement of employment and financial interests is obtained from each special Government employee prior to the beginning of employment or service with the Corporation. The Administrative Officer shall promptly forward the statements to the Ethics Counselor for review.

**§ 905.735-505 Confidentiality of statements.**

The Ethics Counselor shall hold in confidence each statement of employment and financial interests, and each supplementary statement within his control. Access to or disclosure of information contained in these statements shall not be allowed, except as the Commission or the Ethics Counselor determine for good cause shown, consistent with the Privacy Act of 1974 (5 U.S.C. 552a), and the regulations and pertinent notices of systems of records prepared by the Civil Service Commission and the Corporation in accordance with that Act.

**Subpart F—Conduct and Responsibilities of Former Employees—Enforcement**

AUTHORITY: 18 U.S.C. 207(j); sec. 6(5), Pub. L. 92-578, 86 Stat. 1270 (40 U.S.C. 875)(5).

**§ 905.737-101 Applicable provisions of law.**

Former employees of the Corporation must abide by the provisions of 18 U.S.C. 207 and 5 CFR 737.1 through 737.25, which bar certain acts by former Government employees that may reasonably give the appearance of making unfair use of prior Government employment and affiliations. Violation of those provisions will give rise to Corporation enforcement proceedings as

**36 CFR Ch. IX (7-1-03 Edition)**

provided in § 905.737-102, and may also result in criminal sanctions, as provided in 18 U.S.C. 207.

[48 FR 38233, Aug. 23, 1984]

**§ 905.737-102 Enforcement proceedings.**

(a) *Delegation.* The Chairman of the Corporation may delegate his or her authority under this subpart.

(b) *Initiation of disciplinary hearing.*  
(1) Information regarding a possible violation of 18 U.S.C. 207 or 5 CFR part 737 should be communicated to the Chairman. The Chairman shall promptly initiate an investigation to determine whether there is reasonable cause to believe that a violation has occurred.

(2) On receipt of information regarding a possible violation of 18 U.S.C. 207, and after determining that such information appears substantiated, the Chairman of the Corporation shall expeditiously provide such information, along with any comments or regulations of the Corporation, to the Director of the Office of Government Ethics and to the Criminal Division, Department of Justice. The Corporation shall coordinate any investigation with the Department of Justice to avoid prejudicing criminal proceedings, unless the Department of Justice communicates to the Corporation that it does not intend to initiate criminal prosecution.

(3) Whenever the Corporation has determined after appropriate review, that there is reasonable cause to believe that a former employee has violated 18 U.S.C. 207 or 5 CFR part 737, it shall initiate a disciplinary proceeding by providing the former employee with notice as defined in paragraph (c) of this section.

(4) At each stage of any investigation or proceeding under this section, the Chairman shall take whatever steps are necessary to protect the privacy of the former employee. Only those individuals participating in an investigation or hearing shall have access to information collected by the Corporation pursuant to its investigation of the alleged violation.

(c) *Adequate notice.* (1) The Corporation shall provide the former employee with adequate notice of its intention to

institute a proceeding and an opportunity for a hearing.

(2) Notice to the former employee must include:

(i) A statement of the allegations (and the basis thereof) sufficiently detailed to enable the former employee to prepare an adequate defense;

(ii) Notification of the right to a hearing;

(iii) An explanation of the method by which a hearing may be requested; and

(iv) Notification that if a hearing is not requested within thirty days of receipt of notice, the Corporation will issue a final decision finding the alleged violations to have occurred.

(3) Failure to request a hearing within thirty days of the receipt of notice will be deemed an admission of the allegations contained in the notice and will entitle the Corporation to issue a final decision finding the alleged violations to have occurred.

(d) *Presiding official.* (1) The presiding official at proceedings under this subpart shall be the Chairman, or an individual to whom the Chairman has delegated authority to make an initial decision (hereinafter referred to as *examiner*).

(2) An examiner shall be an employee of the Corporation who is familiar with the relevant provisions of law and who is otherwise qualified to carry out the duties of that position. He or she shall be impartial. No individual who has participated in any manner in the decision to initiate the proceedings may serve as an examiner.

(e) *Time, date and place.* (1) The hearing shall be conducted at a reasonable time, date, and place.

(2) On setting a hearing date, the presiding official shall give due regard to the former employee's need for:

(i) Adequate time to prepare a defense properly; and

(ii) An expeditious resolution of allegations that may be damaging to his or her reputation.

(f) *Hearing rights.* A hearing shall include the following rights:

(1) To represent oneself or to be represented by counsel;

(2) To introduce and examine witnesses and to submit physical evidence;

(3) To confront and cross-examine adverse witnesses;

(4) To present oral argument; and

(5) To receive a transcript or recording of the proceedings, on request.

(g) *Burden of proof.* In any hearing under this subpart, the Corporation has the burden of proof and must establish substantial evidence of a violation.

(h) *Hearing decision.* (1) The presiding official shall make a determination exclusively on matters of record in the proceeding, and shall set forth in the decision all findings of fact and conclusions of law relevant to the matters at issue. If the hearing is conducted by the Chairman, the resulting written determination shall be an initial decision.

(2) Within thirty days of the date of an initial decision, either party may appeal the decision to the Chairman. The Chairman shall base his or her decision on such appeal solely on the record of the proceedings on those portions thereof cited by the parties to limit the issues.

(3) If the Chairman modifies or reverses the initial decision, he or she shall specify such findings of fact and conclusions of law as are different from those of the examiner.

(4) If no appeal is taken from an initial decision within thirty days, the initial decision shall become a final decision.

(i) *Sanctions.* The Chairman shall take appropriate action in the case of any individual who is found to be in violation of 18 U.S.C. 207 or 5 CFR part 737 after a final decision by:

(1) Prohibiting the individual from making, on behalf of any other person except the United States, any formal or informal appearance before, or, with the intent to influence, any oral or written communication to, the Corporation on any matter of business for a period not to exceed five years, which may be accomplished by directing employees of the Corporation to refuse to participate in any such appearance or to accept any such communication; or

(2) Taking other appropriate disciplinary action.

(j) *Judicial review.* Any person found by the Corporation to have participated in a violation of 18 U.S.C. 207 or

5 CFR part 737 may seek judicial review of the determination in an appropriate United States District Court.

[48 FR 38233, Aug. 23, 1984]

## PART 906—AFFIRMATIVE ACTION POLICY AND PROCEDURE

### Subpart A—Development Program

Sec.

- 906.1 Purpose and policy.
- 906.2 Definitions.
- 906.3 Procedures.
- 906.4 Formulation of affirmative action plan.
- 906.5 Administration of affirmative action plan.
- 906.6 Implementation.
- 906.7 Incentives.
- 906.8 Review and monitoring.
- 906.9 Voluntary compliance.
- 906.10 Confidentiality.

### Subpart B [Reserved]

EXHIBIT A TO PART 906—SUGGESTED MINIMUM GUIDELINES AND GOALS

EXHIBIT B TO PART 906—GUIDELINES FOR ESTABLISHING STRATEGY TO IMPLEMENT AFFIRMATIVE ACTION PERSONNEL PLAN

AUTHORITY: Pennsylvania Avenue Development Corporation Act of 1972, as amended, sec. 6(6), Pub. L. 92-578, 86 Stat. 1270 (40 U.S.C. 875(6)); E.O. 11625 (36 FR 19967) Oct. 14, 1971; title VII Civil Rights Act of 1964 (42 U.S.C. 2000e-2); Rehabilitation, Comprehensive Services, and Developmental Disabilities Amendments of 1978, secs. 119, 122(d)(2), Pub. L. 95-602, 92 Stat. 2982, 2987 (29 U.S.C. 794); E.O. 12138 (44 FR 29637) May 22, 1979.

SOURCE: 44 FR 37226, June 26, 1979, unless otherwise noted.

### Subpart A—Development Program

#### § 906.1 Purpose and policy.

(a) One of the objectives stated in the Congressionally approved Pennsylvania Avenue Plan—1974 is insuring that minority businesses, investors, and workers have an opportunity to share in the benefits that will occur as a result of redevelopment. Accordingly, the Corporation will take affirmative action to assure full minority participation in activities and benefits that result from implementation of The Pennsylvania Avenue Plan—1974.

(b) It is the policy of the Pennsylvania Avenue Development Corpora-

tion to foster a progressive Affirmative Action Program that affords minorities, women, handicapped persons, and Vietnam era veterans a fair and meaningful share in the opportunities generated by the development activities of the Corporation.

(c) It is mandatory for developers who respond to a solicitation for proposals made by the Corporation to comply with the rules stated in subpart A of part 906.

(d) It is mandatory for developers who receive property interests of ten percent (10%) or more of the area of a development parcel from the Corporation to comply with the rules stated in subpart A of part 906.

(e) The Corporation will encourage any entity not described in paragraphs (c) and (d) of this section to comply with the requirements set forth in this subpart A of part 906.

#### § 906.2 Definitions.

As used in this part:

(a) *Affirmative Action Plan* means a plan which at a minimum includes:

(1) A statement of the affirmative action policy of the development team and a list of the names of the members of the development team including equity investors, and identification of minority owned businesses and investors;

(2) A contracting and purchasing plan;

(3) A leasing plan;

(4) A personnel plan;

(5) An equity investment plan;

(6) The goals, timetables and strategy for achieving the goals of the developer;

(7) A list of specific, quantifiable committed opportunities; and

(8) Designation of an Affirmative Action Officer.

(b) *Committed Opportunity* means an opportunity set aside and committed for the sole involvement of a woman, minority group member, Vietnam era veteran, handicapped person, or minority owned business, including opportunities for training and equity investment.

(c) *Contracting and purchasing plan* means a plan for the subject project which at a minimum includes the following:

(1) A list of all minority enterprises and minority owned businesses that are involved in the development proposal or its implementation;

(2) An analysis of the types of contracts and purchases that will be required by the development team in order to implement the development through and including operation of the completed development;

(3) A list of goals and timetables by category of purchase or contract for involvement of minority owned businesses in the development process;

(4) Strategy for achieving the goals established; and

(5) A list of committed opportunities for the involvement of minority owned businesses in the development process.

(d) *Developer* means a person partnership, company, corporation, association, or other entity that develops a new structure on a site or substantially renovates a structure on a site within the Corporation's development area where the site either: (1) Has been offered to the public by the Corporation for development, or (2) the Corporation has transferred real property rights that equal or exceed ten percent (10%) of the area of the development parcel.

(e) *Development parcel* is an area of land established by the Corporation to be a minimum developable site under The Pennsylvania Avenue Plan—1974, as amended, and The Planning and Design Objectives, Controls, and Standards of the Corporation (36 CFR part 920 *et seq.*).

(f) *Development team* means the group that submits a proposal to develop a parcel including developers, architects, engineers, lawyers, financial institutions, insurance companies, and others who help formulate, develop, and otherwise make a proposal to the Corporation.

(g) *Equity Investment Plan* means a plan for the subject project which at a minimum includes the following:

(1) A statement as to whether or not equity investment has been or will be solicited to implement the subject project;

(2) A statement as to whether or not a joint venture has been or will be formed to implement the subject project;

(3) If equity investment has been solicited or if a joint venture has been formed, a statement of the efforts made to involve members of minority groups and women when these opportunities were offered;

(4) If equity investment will be solicited, or a joint venture will be formed, a plan to involve members of minority groups and women when these opportunities are offered, including a list of committed opportunities;

(5) A list of goals and a timetable for securing participation of members of minority groups and women in equity investment and joint venture.

(h) *Handicapped person* means any person who: (1) Has a physical or mental impairment that substantially limits one or more of the person's major life activities, (2) has a record of such impairment.

(i) *Leasing plan* means a plan for the subject project which at a minimum includes the following:

(1) A retail plan showing the types of retail businesses to be included in the project and a plan for the types of uses for the balance of the development;

(2) Goals and methods for inclusion of minority enterprises as tenants in the project;

(3) Committed opportunities for leasing to minority enterprises.

(j) *Minority Enterprise* means any enterprise that is either a minority owned business or a not for profit or non-profit organization (as defined in 26 U.S.C. 501(c)(3) or (c)(6)) and also fulfills one or more of the following criteria:

(1) The Board of Directors or equivalent policy making body is comprised of members, a majority of whom are minorities or women and the chief executive officer of the organization is a minority group member or a woman; or

(2) The objectives of the organization as described in its charter are substantially directed toward the betterment of minorities or women.

(k) *Minority group member* means any person residing in the United States who is Negro, Hispanic, Oriental, Native American, Eskimo, or Aleut, as defined below:

(1) Negro—is an individual of the Negro race of African origin;

### § 906.3

### 36 CFR Ch. IX (7-1-03 Edition)

(2) **Hispanic**—is an individual who is descended from and was raised in or participates in the culture of Spain, Portugal, or Latin America, or who has at least one parent who speaks Spanish or Portuguese as part of their native culture;

(3) **Oriental**—is an individual of a culture, origin, or parentage traceable to the areas south of the Soviet Union, East of Iran, inclusive of the islands adjacent thereto, located in the Pacific including, but limited to, Taiwan, Indonesia, Japan, Hawaii, and the Philippines, together with the islands of Polynesia;

(4) **Native American**—is an individual having origins in any of the original people of North America, who is recognized as an Indian by either a tribe, tribal organization, or suitable authority in the community. For purposes of this section a suitable authority in the community may be an educational institution, a religious organization, or a state or Federal agency.

(5) **Eskimo**—is an individual having origins in any of the original peoples of Alaska;

(6) **Aleut**—is an individual having origins in any of the original peoples of the Aleutian Islands.

(1) **Minority owned business** means a business that is:

(1) A sole proprietorship owned by a minority group member or a woman;

(2) A business entity at least 50 percent of which is owned by minority group members or women;

(3) A publicly owned business at least 51 percent of the stock of which is owned by minority group members or women;

(4) A certified minority owned business as evidenced by a certificate satisfactory to the Corporation's Affirmative Action Officer, and signed by the owner or the executive officer of the minority owned business.

For purposes of this definition, ownership means that the risk of gain or loss and the amount of control exercised must be equivalent to the ownership percentage.

(m) **Personnel plan** means a plan for the subject project which at a minimum includes the following:

(1) An analysis of participation of minority group members, women, Viet-

nam era veterans, and handicapped persons in the development project including an evaluation by category of employment, i.e., professional and managerial, skilled, semi-skilled, trainee, and other, and the number of employees in each category;

(2) An analysis of the salaries of minority group members, women, handicapped persons, and Vietnam era veterans showing the relative position of these employees with those not covered by the Affirmative Action Plan;

(3) Goals and timetables for employment by category and salary level of minorities, women, Vietnam era veterans, and handicapped persons employed for the development parcel;

(4) Strategy for achieving the goals established (see Exhibit B);

(5) A list of committed opportunities for the employment of minority group members, women, Vietnam era veterans, and handicapped persons.

(n) **Vietnam era veteran** means a person who:

(1) Served on active duty for a period of more than 180 days, any part of which occurred during the Vietnam era, and was discharged or released therefrom with other than a dishonorable discharge; or

(2) Was discharged or released from active duty for a service-connected disability if any part of such active duty was performed during the Vietnam era.

### § 906.3 Procedures.

(a) Affirmative Action Plans must be submitted to the Corporation at the following times:

(1) At the time a response is submitted to the Corporation's solicitation for proposals, the response must include an Affirmative Action Plan;

(2) If a property right exceeding 10 percent of the area of the development parcel is made available by the Corporation, but without the Corporation having made a solicitation for proposals, the developer must submit an Affirmative Action Plan within 30 days after the start of negotiations with the Corporation.

(b) Affirmative Action Plans will be reviewed as follows:

(1) Each Affirmative Action Plan submitted to the Corporation will be reviewed by the Corporation's Affirmative Action Officer, or his designee.

(2) In the case of a developer who responds to a solicitation for proposals, the Affirmative Action Plan will be reviewed by the Affirmative Action Officer, and if the Plan is in substantial compliance with the goals set forth in Exhibit A, the Plan and the recommendation of the Affirmative Action Officer will be submitted to the Chairman of the Board for approval prior to the Board's final selection.

(3) In the case of a developer who receives 10 percent or more of the area of a development parcel from the Corporation, the Affirmative Action Plan will be reviewed by the Corporation's Affirmative Action Officer, and if the Plan is in substantial compliance with the goals set forth in Exhibit A, the Plan and the recommendation of the Affirmative Action Officer will be submitted to the Chairman of the Board for approval within 15 days of submission.

(4) The Chairman may approve any Affirmative Action Plan that is not in substantial compliance with the goals set forth in Exhibit A, but for which the developer has documented a genuine effort to meet the goals of the regulations and complied with the spirit of the Corporation's policy.

(5) The Chairman may, in his discretion, submit any Affirmative Action Plan to the Board of Directors for approval, if there is not substantial compliance with the goals set forth in Exhibit A.

(6) The review of the Affirmative Action Plan will determine conformity with The Pennsylvania Avenue Plan—1974, the policy of the Corporation's Board of Directors, and the regulations and guidelines set forth in this subpart A, part 906.

(c) Revisions: (1) The Corporation may require a developer at any time prior to approval of the Affirmative Action Plan to revise the Plan for compliance with the requirements of this subpart.

(2) Each developer required to comply with this subpart must submit for approval an up-dated Affirmative Action Plan at the commencement of

construction, at the commencement of occupancy, and at the commencement of operation or management of any portion of the facility by the developer or a related entity. Each revision of the Affirmative Action Plan must address all the requirements set forth in § 906.4.

(3) The Corporation's Affirmative Action Officer will review all revisions submitted to the Corporation. If the revision is a substantial change from the originally approved Plan, the review procedures set forth in paragraph (b) of this section will be applicable. If the revision submitted is not a substantial change from the originally approved Plan, the Corporation's Affirmative Action Officer may approve the revision.

**§ 906.4 Formulation of affirmative action plan.**

(a) The developer, in formulating the Affirmative Action Plan, should consider all phases of development from establishment of the development team to operation and management of the development project including each component of the project (e.g., hotel, retail, office, residential). The developer should also consider the personnel profile of project contractors, sub-contractors.

(b) For each phase and each component, the developer should give consideration to creating business and employment opportunities and committed opportunities in the following:

- (1) Equity participation;
- (2) Professional and technical services such as legal, architectural, engineering, and financial;
- (3) Purchasing materials and supplies in connection with construction and operation;
- (4) Contracting for construction, operation, and maintenance; and,
- (5) Financing, including construction and permanent financing, and other financial and banking services.

**§ 906.5 Administration of affirmative action plan.**

(a) The developer shall appoint an Affirmative Action Officer, and for projects exceeding \$10 million in cost,

## § 906.6

the person appointed must have affirmative action as a primary responsibility.

(b) The developer shall report to the Corporation periodically its progress in meeting the goals and timetables in its Affirmative Action Plan with respect to its contracting and purchasing plan, leasing plan, and committed opportunities. In meeting the reporting requirements the developer shall:

(1) Count an individual only once for reporting purposes;

(2) Count an individual in the first appropriate category as follows:

(i) Minority Group Member;

(ii) Handicapped Person;

(iii) Woman;

(iv) Vietnam Era Veteran;

(3) Report the dollar amount of contracts and purchases from minority owned businesses including sub-contracts;

(4) In the event 10 percent or more of the dollar amount of a contract, sub-contract, or purchase from a minority owned business is performed by other than a minority owned business, the developer shall report only the dollar amount performed by the minority owned business.

## § 906.6 Implementation.

(a) Each developer's Affirmative Action Plan will be incorporated into the real estate agreement between the developer and the Corporation.

(b) Each developer shall include a clause requiring a contracting and purchasing plan and a personnel plan in any contract exceeding \$500,000.

(c) Each developer should consider including a clause requiring a contracting and purchasing plan and a personnel plan in any contract less than \$500,000.

(d) In order that the Corporation may be of assistance, and to the extent practical, the developer shall notify the Corporation's Affirmative Action Officer of any failure to meet the approved Affirmative Action Plan.

(e) The Corporation, at the request of the developer, shall provide the developer with assistance for meeting the goals set forth in the Affirmative Action Plan. Such assistance may be provided in the form of lists of minority enterprises, sources for recruiting and

## 36 CFR Ch. IX (7-1-03 Edition)

advertising, as well as other available information.

## § 906.7 Incentives.

(a) At the request of the developer, the Corporation may agree to deferral of a portion of rental, not to exceed 50 percent, during construction and during the first year of operation following construction of any phase of the development project. Allowable rent deferral during the construction phase will be two percent of the total base rent for each one percent of the value of all construction contracts which have been awarded to Minority Owned Businesses, not to exceed 50 percent. Rent deferral during the first year of operation following construction of any phase of the development project will be four percent for each one percent of total equity owned by minority group members, minority owned businesses, and women.

(b) Following review of Affirmative Action reports submitted to the Corporation pursuant to § 906.5(b), the Corporation will determine the developer's compliance with the goals set forth in the approved Affirmative Action Plan. Compliance with the goals established in the Plan will be measured by adding the percentages reported including overages in each category and dividing that by the number of categories covered in the Plan.

(c) If 75 percent compliance is not achieved during any rent deferral period, the Corporation will afford the developer 120 days to achieve at least that level of compliance. If, at the end of that 120 day period, 75 percent compliance is not achieved, all rental deferral, together with interest, will be due and payable to the Corporation on the 10th day following receipt of written notice that payment of the deferred rent has been accelerated.

## § 906.8 Review and monitoring.

The Corporation, either by its employees, consultants, or other government agency, shall analyze and monitor compliance with the developer's approved Affirmative Action Plan. The Corporation shall rely on the reports submitted by the developer. However:



(a) Further investigation by the Corporation may be undertaken if problems are brought to the attention of the Corporation through any reliable source, or if any formal complaints are filed against the developer that relate to performance of the Affirmative Action Plan; and

(b) The Corporation reserves the right to audit the records of the developer that pertain to any report submitted to the Corporation.

**§906.9 Voluntary compliance.**

The Corporation will encourage any individual or entity not described in §906.1(c) or (d) to submit and adopt an Affirmative Action Plan on any development project for which the Corporation's review and approval is required to determine conformity of the development project with the The Pennsylvania Avenue Plan—1974. Any such Affirmative Action Plan should accompany the development plans.

**§906.10 Confidentiality.**

All information submitted to the Corporation pursuant to this subpart A will be kept confidential, except as availability to the public may be required by the Freedom of Information Act.

**Subpart B [Reserved]**

**EXHIBIT A TO PART 906—SUGGESTED MINIMUM GUIDELINES AND GOALS**

The following are suggested for consideration by developers in formulation of minimum affirmative action goals for the development parcel:

(a) Equity participation—10 percent participation by minority group members, women, and minority owned businesses as investors in ownership of the development parcel.

(b) Contracts for professional and technical services—20 percent of the dollar value of the contracts to minority owned businesses.

(c) Persons providing professional or technical services—20 percent should be minority group members, women, handicapped persons, or Vietnam era veterans.

(d) Construction contracting—15 percent of the total dollar value to minority owned businesses. (In order to accomplish this goal, the developer must require that any prime contractor show at least 15 percent minority

subcontractors unless the prime contractor is a minority contractor.)

(e) Construction employment should comply with the Washington Plan as a minimum.

(f) Purchasing—20 percent of the dollar value of all purchases of materials and supplies to minority owned businesses.

(g) Hotel employment—20 percent of all hotel employees, 15 percent of all personnel earning an excess of \$2,000 a month (in 1978 dollars), and 60 percent of trainees for hotel positions should be minority group members, women, handicapped persons, or Vietnam era veterans.

(h) Leasing of space—15 percent of the retail space should be targeted for minority enterprises.

(i) Committed opportunities—should be created for professional, technical, construction, hotel, or other type operations where the representation of minority group members, women, or handicapped persons in a field is inconsistent with the demographic profile of the Washington metropolitan area.

**EXHIBIT B TO PART 906—GUIDELINES FOR ESTABLISHING STRATEGY TO IMPLEMENT AFFIRMATIVE ACTION PERSONNEL PLAN**

The following are suggested as the types of activities to be considered in the development of strategies for the affirmative action personnel plan:

(1) "Vigorous" searching for qualified minority and women applicants for job openings in professional and managerial positions, often including recruitment visits to educational institutions with large minority or female enrollments.

(2) Wide dissemination of affirmative action policy in advertisements and employment literature.

(3) Utilization of minority media in recruitment advertisements.

(4) Notification of job openings to minority community organizations and associations.

(5) Listing of all employment openings with compensation of under \$20,000 per year at a local office of the State Employment Service (or union hiring hall when union labor is required).

(6) Periodic review of minority, female, Vietnam era veteran, and handicapped employees to identify underutilized and unutilized skills and knowledge as well as opportunities for reassignment.

(7) Utilization of merit promotion and on-the-job training programs to create career ladders or otherwise qualify minority, female, Vietnam era veteran, and handicapped employees for advancement.

## PART 907—ENVIRONMENTAL QUALITY

- Sec.  
 907.1 Policy.  
 907.2 Purpose.  
 907.3 Definitions.  
 907.4 Designation of responsible Corporation official.  
 907.5 Specific responsibilities of designated Corporation official.  
 907.6 Major decision points.  
 907.7 Determination of requirement for EIS.  
 907.8 Actions that normally require an EIS.  
 907.9 Preparation of an EIS.  
 907.10 Categorical exclusions.  
 907.11 Actions that normally require an environmental assessment.  
 907.12 Preparation of an environmental assessment.  
 907.13 Public involvement.  
 907.14 Corporation decision making procedures.  
 907.15 Approval of private development proposals.  
 907.16 Actions where lead Agency designation is necessary.

### APPENDIX A TO PART 907

AUTHORITY: 40 U.S.C. 875(8); 42 U.S.C. 4321.

SOURCE: 47 FR 8768, Mar. 2, 1982, unless otherwise noted.

#### § 907.1 Policy.

The Pennsylvania Avenue Development Corporation's policy is to:

(a) Use all practical means, consistent with the Corporation's statutory authority, available resources, and national policy, to protect and enhance the quality of the human environment;

(b) Ensure that environmental factors and concerns are given appropriate consideration in decisions and actions by the Corporation;

(c) Use systematic and timely approaches which will ensure the integrated use of the natural and social sciences and environmental design arts in planning and decision making which may have an impact on the human environment;

(d) Develop and utilize ecological and other environmental information in the planning and development of projects implementing the Plan;

(e) Invite the cooperation and encourage the participation, where appropriate, of Federal, District of Columbia, and regional authorities and the public in Corporation planning and de-

cision-making processes, which affect the quality of the human environment; and

(f) Minimize any possible adverse effects of Corporation decisions and actions upon the quality of the human environment.

#### § 907.2 Purpose.

These regulations are prepared to supplement Council on Environmental Quality Regulations for implementing the procedural provisions of the National Environmental Policy Act of 1969, as amended, and describe how the Pennsylvania Avenue Development Corporation intends to consider environmental factors and concerns in the Corporation's decision making process.

#### § 907.3 Definitions.

(a) *CEQ Regulations* means the regulations for implementing the procedural provisions of the National Environmental Policy Act of 1969 as promulgated by the Council on Environmental Quality, Executive Office of the President, appearing at 40 CFR parts 1500-1509 (43 FR 55978-56007) and to which this part is a supplement.

(b) *The Act of October 27, 1972* or *Act* means the Pennsylvania Avenue Development Corporation Act of 1972, Pub. L. 92-578, October 27, 1972, 86 Stat. 1266 (40 U.S.C. 871).

(c) *The Plan* means the Pennsylvania Avenue Plan—1974, prepared by the Pennsylvania Avenue Development Corporation pursuant to the Act of October 27, 1972.

(d) *The Corporation* means the Pennsylvania Avenue Development Corporation, a wholly owned government corporation of the United States created by the Act of October 27, 1972.

(e) *Board of Directors* means the governing body of the Corporation in which the powers and management of the Corporation are vested by the Act of October 27, 1972.

(f) *EIS* means an environmental impact statement as defined in § 1508.11 of the CEQ Regulations.

(g) *Final EIS* means The Final Environmental Impact Statement, dated September 1974, prepared by the Corporation on The Pennsylvania Avenue Plan—1974.

(h) *Development Area* means the area under the Corporation's jurisdiction as specified in section 2(f) of the Act of October 27, 1972 and for which The Plan has been prepared and will be implemented by the Corporation.

(i) *Decision Maker* means the Board of Directors, unless a delegation to the Chairman, a member or committee of the Board of Directors, or the Executive Director has been made by the By-laws of the Corporation, a resolution of the Board of Directors, or an appropriate written delegation of authority.

(j) *Private Developer* means an individual, firm, joint venture, or other entity other than the Corporation which seeks to construct, reconstruct, rehabilitate, or restore real property within the development area.

(k) Other terms used in this part are defined in 40 CFR part 1508 of the CEQ Regulations.

**§ 907.4 Designation of responsible Corporation official.**

The Development Director is the Corporation official responsible for implementation and operation of the Corporation's policies and procedures on environmental quality and control.

**§ 907.5 Specific responsibilities of designated Corporation official.**

(a) Coordinate the formulation and revision of Corporation policies and procedures on matters pertaining to environmental protection and enhancement.

(b) Establish and maintain working relationships with relevant government agencies concerned with environmental matters.

(c) Develop procedures within the Corporation's planning and decision-making processes to ensure that environmental factors are properly considered in all proposals and decisions in accordance with this part.

(d) Develop, monitor, and review the Corporation's implementation of standards, procedures, and working relationships for protection and enhancement of environmental quality and compliance with applicable laws and regulations.

(e) Monitor processes to ensure that the Corporation's procedures regarding

consideration of environmental quality are achieving their intended purposes.

(f) Advise the Board of Directors, officers, and employees of the Corporation of technical and management requirements of environmental analysis, of appropriate expertise available, and, with the assistance of the Office of the General Counsel, of relevant legal developments.

(g) Monitor the consideration and documentation of the environmental aspects of the Corporation's planning and decisionmaking processes by appropriate officers and employees of the Corporation.

(h) Ensure that all environmental assessments and, where required, all EIS's are prepared in accordance with the appropriate regulations adopted by the Council on Environmental Quality and the Corporation, and are submitted with all proposed legislation.

(i) Consolidate and transmit to appropriate parties the Corporation's comments on EIS's and other environmental reports prepared by other agencies.

(j) Acquire information and prepare appropriate reports on environmental matters required of the Corporation. Information collection activities will be conducted in accordance with the Paperwork Reduction Act of 1980 and approval of OMB will be obtained prior to commencing such activities.

(k) Coordinate Corporation efforts to make available to other parties information and advice on the Corporation's policies for protecting and enhancing the quality of the environment.

**§ 907.6 Major decision points.**

(a) The possible environmental effects of a proposed action or project must be considered along with technical, economic, and other factors throughout the decisionmaking process. For most Corporation projects there are three distinct stages in the decision making process:

- (1) Conceptual or preliminary stage;
- (2) Detailed planning or final approval stage;
- (3) Implementation stage.

(b) Environmental review will be integrated into the decision making process of the Corporation as follows:

## § 907.7

## 36 CFR Ch. IX (7-1-03 Edition)

(1) During the conceptual or preliminary approval study stage, the responsible Corporation official shall determine whether the proposed action or project is one which is categorically excluded, requires an environmental assessment or an EIS.

(2) Prior to proceeding from the conceptual or preliminary approval stage to the detailed planning or final approval stage, an environmental assessment and the determination as to whether an EIS is required must be completed.

(3) An EIS, if determined necessary, must be completed and circulated prior to the decision to proceed from the detailed planning stage to implementation.

### § 907.7 Determination of requirement for EIS.

Determining whether to prepare an environmental impact statement is the first step in applying the NEPA process. In deciding whether to prepare an environmental impact statement, the responsible Corporation official will determine whether the proposal is one that:

(a) Normally requires an environmental impact statement.

(b) Normally does not require either an environmental impact statement or an environmental assessment (categorical exclusion).

(c) Normally requires an environmental assessment, but not necessarily an environmental impact statement.

### § 907.8 Actions that normally require an EIS.

PADC shall perform or have performed an environmental assessment to determine if a proposal requires an environmental impact statement. However, it may be readily apparent that a proposed action will have a significant impact on the environment; in such cases, an environmental assessment is not required and PADC will immediately begin to prepare or have prepared the environmental impact statement. To assist in determining if a proposal or action normally requires the preparation of an environmental impact statement, the following criteria and categories of action are provided.

(a) *Criteria.* Criteria used to determine whether or not actions or proposals may significantly affect the environment and therefore require an environmental impact statement are described in 40 CFR 1508.27 of the CEQ Regulations and as follows:

(1) Buildings or facades designated for retention in the Plan will be adversely affected by the proposal or action.

(2) Traffic generated by the proposal or action would represent a substantial increase over the traffic projections assessed in the Final EIS in the average daily traffic volume on avenues and streets within the Development Area or its environs;

(3) Air quality in the Development Area and its environs would be substantially affected by the proposal or action based upon the District of Columbia's adopted standard for hydrocarbons and carbon monoxide;

(4) Solid waste disposal generated by a project of the Corporation or of a developer who is constructing, reconstructing, or rehabilitating that project, would have an adverse effect on the capacity of the relevant solid waste disposal facility and compliance with "Solid Waste Management Guidelines" of the U.S. Environmental Protection Agency and related local and regional controls;

(5) Public utilities have insufficient capacity to provide reliable service to a project within the Development Area; and

(6) A project will be inconsistent with major elements of the Zoning Regulations of the District of Columbia as they are applicable to the Development Area.

(b) *Categories of action.* The following categories of action normally require an environmental impact statement:

(1) Amendments or supplements to the Plan that constitute a "substantial change" to the Plan as defined in 40 U.S.C. 874(c) of the Act.

(2) Acquisition or disposal of real property by the Corporation *not* related to any specific decision, plan, or program adopted by the Board of Directors of the Corporation for which an environmental assessment or an assessment and an EIS has been prepared.

(3) Legislative proposals made to Congress.

(4) Funding and/or construction by the Corporation or its agents or representatives of any building, if that activity is not consistent with the Plan and the Final EIS.

**§ 907.9 Preparation of an EIS.**

(a) *Notice of intent.* When PADC decides to prepare an environmental impact statement, it shall publish a notice of intent in the FEDERAL REGISTER in accordance with 40 CFR 1501.7 and 1508.22 of the CEQ Regulations.

(b) *Preparation.* After determining that an environmental impact statement will be prepared and publishing the notice of intent, PADC will begin to prepare or have prepared the environmental impact statement. Procedures for preparing the environmental impact statement are set forth in 40 CFR part 1502, CEQ Regulations.

(c) *Supplemental environmental impact statements.* PADC may supplement a draft or final environmental impact statement at any time. PADC shall prepare a supplement to either the draft or final environmental impact statement when (1) substantial changes are proposed to an action contained in the draft or final EIS that are relevant to environmental concerns or there are significant new circumstances or information relevant to environmental concerns and bearing on the proposed action or its impacts; or (2) actions are proposed which relate or are similar to other action(s) taken or proposed and that together will have a cumulatively significantly impact on the environment.

**§ 907.10 Categorical exclusion.**

The CEQ Regulations provide for the categorical exclusion (40 CFR 1508.4) of actions that do not individually or cumulatively have a significant effect on the human environment. Therefore, neither an environmental assessment nor an environmental impact statement is required for such actions.

(a) *Criteria.* Criteria used to determine those categories of action that normally do not require either an environmental impact statement or an environmental assessment include:

(1) The action or proposal is consistent with the Plan or the Act, and the environmental effects have been previously analyzed in the Final EIS, a supplement thereto, or in an environmental assessment or an EIS previously prepared; or

(2) The total estimated cost directly attributable to the action or proposal does not exceed \$500,000; or

(3) The action or proposal is related solely to internal administrative operations of the Corporation.

(b) *List of categorical exclusions.* Categories of action, identified in appendix A (attached) have been determined by PADC to have no significant effect on the human environment and are therefore categorically excluded from the preparation of environmental impact statements and environmental assessments.

(c) *Changes to the list of categorical exclusion.* (1) The PADC List of Categorical Exclusion will be continually reviewed and refined as additional categories are identified and as experience is gained in the categorical exclusion process.

(2) Additional categories of exclusion identified will be submitted to the Chairman of the Board of Directors for review and approval, and for amendments to this part, following public comment and review by the Council on Environmental Quality.

**§ 907.11 Actions that normally require an environmental assessment.**

If a proposal or action is not one that normally requires an environmental impact statement, and does not qualify for categorical exclusion, PADC will prepare or have prepared an environmental assessment.

(a) *Criteria.* Criteria used to determine those categories of action that normally require an environmental assessment, but not necessarily an environmental impact statement, include:

(1) Potential for minor degradation of environmental quality;

(2) Potential for cumulative impact on environmental quality; and

(3) Potential for impact on protected resources.

(b) *Categories of action.* The following categories of action normally require

## § 907.12

## 36 CFR Ch. IX (7-1-03 Edition)

the preparation of an environmental assessment.

(1) Amendments to the Plan that do not constitute a “substantial change” to the Plan.

(2) Regulations promulgated by the Corporation that have significant environmental impact on the public or persons residing in the development area including businesses.

(3) Development proposals submitted to the Corporation by private developers that are consistent with the Plan and General Guidelines prepared by the Corporation.

(4) Activities related to the Public Improvements Program of the Corporation for which no previous environmental assessment or EIS has been prepared.

(5) Contracts, work authorizations, and master agreements related to and implementing programs, policies, and proposals not categorically excluded and for which no environmental assessments or for which no environmental assessment and EIS have been previously prepared.

(6) Street closures and other rearrangements of public space which were not covered in the Plan or the Final EIS.

(7) Acquisition/disposal of personal property by the Corporation not related to any specific decision, plan, or program adopted by the Board of Directors of the Corporation for which an environmental assessment or an environmental assessment and an EIS is required to be prepared.

(8) Proposed construction of any public building within the development area by any executive agency of the United States Government, any agency or department of the District of Columbia Government, or any other public or quasi-public entity.

### § 907.12 Preparation of an environmental assessment.

(a) *When to prepare.* PADC will begin the preparation of an environmental assessment as early as possible after it is determined by the responsible corporation official to be required. PADC may prepare an environmental assessment at any time to assist planning and decision-making.

(b) *Content and format.* An environmental assessment is a concise public document used to determine whether to prepare an environmental impact statement. An environmental assessment aids in complying with the Act when no environmental impact statement is necessary, and it facilitates the preparation of an environmental impact statement, if one is necessary. The environmental assessment shall contain brief discussions of the following topics:

(1) Purpose and need for the proposed action.

(2) Description of the proposed action.

(3) Alternatives considered, including the No Action alternative.

(4) Environmental effects of the proposed action and alternative actions.

(5) Listing of agencies, organizations or persons consulted.

(6) In preparation of the environmental assessment, the most important or significant environmental consequences and effects on the areas listed below should be addressed. Only those areas which are specifically relevant to the particular proposal should be addressed. Those areas should be addressed in as much detail as is necessary to allow an analysis of the alternatives and the proposal. The areas to be considered are the following:

(i) Natural/ecological features (such as floodplain, wetlands, coastal zones, wildlife refuges, and endangered species);

(ii) Air quality;

(iii) Sound levels;

(iv) Water supply, wastewater treatment and water runoff;

(v) Energy requirements and conservation;

(vi) Solid waste;

(vii) Transportation;

(viii) Community facilities and services;

(ix) Social and economic;

(x) Historic and aesthetic; and

(xi) Other relevant factors.

(c) *Finding of no significant impact.* If PADC completes an environmental assessment and determines that an environmental impact statement is not required, then PADC shall prepare a finding of no significant impact. The finding of no significant impact shall be

## Pennsylvania Avenue Development Corporation

## § 907.16

made available to the public by PADDC as specified in 40 CFR 1506.6 of the CEQ Regulations.

### § 907.13 Public involvement.

Interested persons may obtain information concerning any pending EIS or any other element of the environmental review process of the Corporation by contacting the Public Information Officer of the Corporation, 1331 Pennsylvania Avenue, NW, Suite 1220 North, Washington, DC 20004, telephone (202) 566-1218.

[47 FR 8768, Mar. 2, 1982, as amended at 50 FR 45824, Nov. 4, 1985]

### § 907.14 Corporation decision making procedures.

To ensure that at major decision making points all relevant environmental concerns are considered by the Decision Maker, the following procedures are established.

(a) An environmental document, i.e., the EIS, Environmental Assessment, Finding of No Significant Impact, or Notice of Intent, in addition to being prepared at the earliest point in the decision making process, shall accompany the relevant proposal or action through the Corporation's decision making process to ensure adequate consideration of environmental factors.

(b) The decision maker shall consider in its decision making process only those decision alternatives discussed in the relevant environmental documents. Also, where an EIS has been prepared, the decision maker shall consider all alternatives described in the EIS. A written record of the consideration of alternatives during the decision making process shall be maintained.

(c) Any environmental document prepared for a proposal or action shall be made part of the record of any formal rulemaking by the Corporation.

### § 907.15 Approval of private development proposals.

(a) Each development proposal submitted by a private developer to the Corporation for its approval, unless categorically excluded, shall require, at a minimum, an environmental assessment.

(b) The Board of Directors may not take any approval action on a submitted development proposal of a private developer until such time as the appropriate environmental review has been prepared and submitted to the Board of Directors.

(c) At a minimum, and as part of any submission made by a private developer to the Board of Directors for its approval, a private developer shall make available data and materials concerning the development proposal sufficient to permit the Corporation to carry out its responsibilities on environmental review. When requested, the developer shall provide additional information that the Corporation believes is necessary to permit it to satisfy its environmental review functions.

(d) As part of a development proposal submission, a private developer may submit an environmental assessment on its development proposal.

(e) Where the responsible Corporation official determines that the preparation of an EIS is required, the EIS shall be prepared in accordance with part 1502 of the CEQ Regulations. The responsible Corporation official may set time limits for environmental review appropriate to each development proposal, consistent with CEQ Regulations 40 CFR 1601.8 and 1506.10.

(f) The responsible Corporation official shall at the earliest possible time ensure that the Corporation commences its environmental review on a proposed development project and shall provide to a private developer any policies or information deemed appropriate in order to permit effective and timely review by the Corporation of a development proposal once it is submitted to the Board of Directors for approval. The official shall designate, for the benefit of the developer, staff members of the Corporation to advise the developer with regard to information that may be required in order to accomplish the Corporation's environmental review.

### § 907.16 Actions where lead Agency designation is necessary.

(a) Consistent with CEQ Regulations, § 1501.5, where a proposed action by the Corporation involves one or more other

Federal agencies, or where a group of actions by the Corporation and one or more other Federal agencies are directly related to each other because of their functional interdependence or geographical proximity, the Corporation will seek designation as lead agency for those actions that directly relate to implementation of the Plan and those actions that relate solely to the Development Area.

(b) For an action that qualifies as one for which the Corporation will seek designation as lead agency, the Corporation will promptly consult with the appropriate Federal agencies such as the National Capital Planning Commission, the Department of the Interior, and the General Services Administration to establish lead agency and co-operating agency designations.

#### APPENDIX A TO PART 907

(a) Specific Corporation actions categorically excluded from the requirements for environmental assessment and an EIS are:

- (i) Personnel actions;
- (ii) Administrative actions and operations directly related to the operation of the Corporation (e.g., purchase of furnishings, services, and space acquisition for the Corporation offices);
- (iii) Property management actions related to routine maintenance, operation, upkeep, etc., of real property owned by the Corporation;
- (iv) Review of permit applications relating to minor development activities in the Development Area (sign approval, interior renovations, minor exterior changes to facade, etc.);
- (v) Promulgation of development general and square guidelines that implement the Plan as covered by the Final EIS;
- (vi) Contracts, work authorizations, procurement actions directly related to and implementing proposals, programs, and master agreements for which an environmental assessment or an environmental assessment and an EIS have been prepared, or which are related to administrative operation of the agency;
- (vii) Acquisition/disposal by lease, easement, or sale of real and personal property owned by the Corporation subsequent to and implementing a prior decision of the Board of Directors for which an environmental assessment or an assessment and an EIS were prepared;
- (viii) Activities directly related to and implementing the Public Improvements Program of the Corporation approved by the Board of Directors, and which are covered by

a previously prepared environmental assessment or an environmental assessment and an EIS;

(ix) Demolition actions preparatory for development by the Corporation, other public agencies, or private developers subsequent to approval of development proposals made by the Board of Directors;

(x) Development proposal identical to the requirements of the Plan and which was included in an EIS previously prepared.

(b) An action which falls into one of the above categories may still require the preparation of an EIS or environmental assessment if the designated corporation official determines it meets the criteria stated in §907.8(a) or involves extraordinary circumstances that may have a significant environmental effect.

### PART 908—POLICY AND PROCEDURES TO FACILITATE THE RETENTION OF DISPLACED BUSINESSES AND RESIDENTS IN THE PENNSYLVANIA AVENUE DEVELOPMENT AREA

#### Subpart A—General

Sec.

- 908.1 Policy.
- 908.2 Purpose.
- 908.3 Definitions.

#### Subpart B—Preferential Right To Relocate

- 908.10 Criteria of Qualified Persons.
- 908.11 List of Qualified Persons.
- 908.12 Retention on the List of Qualified Persons.
- 908.13 Rights of Qualified Persons.
- 908.14 Requirements placed on developers that have acquired or leased real property from the Corporation.
- 908.15 Requirements placed on developers that have not acquired or leased real property from the Corporation.

#### Subpart C [Reserved]

#### Subpart D—Review Procedure

- 908.30 Request for review.
- 908.31 Time for filing request for review.
- 908.32 Review procedures.
- 908.33 Final determination.

AUTHORITY: 40 U.S.C. 874(e); 40 U.S.C. 875(8); 40 U.S.C. 877(d).

SOURCE: 48 FR 55459, Dec. 13, 1983, unless otherwise noted.



**Subpart A—General**

**§ 908.1 Policy.**

One of the goals of The Pennsylvania Avenue Plan—1974, as amended, (*The Plan*) is the reduction of hardships experienced by businesses and residents within the development area of the Pennsylvania Avenue Development Corporation (*the Corporation*) when they are displaced as a result of implementation of The Plan. It is the policy of the Corporation to provide displaced businesses and residents with a preferential opportunity to relocate within the development area so that they may share in the benefits brought to the area by the implementation of The Plan. This rule shall not be construed to affect the eligibility, rights or responsibilities of persons who may be entitled to benefits provided under the Uniform Relocation Assistance and Real Property Acquisition Policies Act of 1970 as implemented by the Corporation (36 CFR part 904).

**§ 908.2 Purpose.**

The purpose of this rule is to:

- (a) Provide a meaningful opportunity to businesses displaced by the Corporation's program to return to, or remain in, the Development Area;
- (b) Establish procedures and requirements for displaced occupants by which they may establish and later exercise their preferential right to return to the Development Area;
- (c) Establish procedures which the Corporation and private Developers must follow in providing Qualified Persons with the opportunity to obtain their preferential right to return to the Development Area.

**§ 908.3 Definitions.**

The following definitions shall apply to this part:

- (a) *Developer* means a Person or team of Persons that has received preliminary approval for a development proposal or has been designated by the Corporation as Developer pursuant to a development competition.
- (b) *Development Area* means the area described in section 2 (f) of Pub. L. 92-578, October 27, 1972, as amended (40 U.S.C. 871 (f)), and for which the Plan

has been prepared and will be implemented by the Corporation.

(c) *List* means the List of Qualified Persons maintained by the Corporation as provided in §908.11(a) of this rule.

(d) *Newly developed space* means any leaseable part of a new building in the Development Area upon which construction was commenced after October 27, 1972 or an existing building in the Development Area which after October 27, 1972 underwent substantial remodeling, renovation, conversion, rebuilding, enlargement, extension or major structural improvement, but not including ordinary maintenance or remodeling or changes necessary to continue occupancy.

(e) *Person* means a partnership, company, corporation, or association as well as an individual or family, but does not include a department, agency, or instrumentality of any Federal, state, or local government.

(f) *Previous location* means the space from which the Eligible Person was or is being displaced as a result of the Corporation's or Developer's acquisition of real property, or as a result of receiving a written order to vacate from the Corporation.

**Subpart B—Preferential Right To Relocate**

**§ 908.10 Criteria of Qualified Person.**

*Qualified Person* is either

- (a) A Person whose place of business or residence was located in the Development Area and was displaced from its location by:
  - (1) The Corporation in connection with the acquisition of fee title, or a lesser interest, in the real property containing such business or residence; or
  - (2) A Developer in implementing a development project in accordance with the Plan; or
- (b) A Person whose place of business or residence is located in the Development Area and who has received notice of initiation of negotiations by the Corporation for purchase of the real property containing such business or residence.

## § 908.11

### § 908.11 List of Qualified Persons.

(a) The Corporation shall develop and maintain a List of Qualified Persons who meet the criteria of Qualified Person as defined in §908.10 and who ask to be placed on that list.

(b) The Corporation shall notify each occupant displaced by development provided an address is available to the Corporation, of this policy and the procedures to be followed for placement on the List.

(c) A person who wishes to be included on the List shall notify the Corporation in writing to that effect. The notice to the Corporation shall include:

(1) The address of the Previous Location;

(2) A short statement indicating the nature of the Qualified Person's occupancy;

(3) The amounts and type of space occupied prior to displacement;

(4) A description of any specialized equipment or unusual requirements for occupancy; and

(5) A copy of the notice to vacate from the Developer or notice of initiation of negotiations from the Corporation if either of these was received by the Qualified Person.

(d) The Corporation shall:

(1) Review the information furnished by the Person including any notice;

(2) Request additional information, if necessary to make a determination of the Person's qualifications;

(3) Determine whether the Person is qualified to be listed, and if so place the Person on the list; and

(4) Notify the Person of its determination.

(e) The Corporation urges that any Person who wishes to be placed on the List request such placement as soon as the Person meets the criteria for Qualified Person established in §908.10, and all Persons are encouraged to do so no later than one year of the time the Person is displaced in order to increase the opportunity to obtain Newly Developed Space. However, no Person shall be denied placement on the List because such placement was not requested within one year of displacement.

## 36 CFR Ch. IX (7-1-03 Edition)

### § 908.12 Retention on the List of Qualified Persons.

(a) Once placed on the List, the Corporation shall keep a Person on the List until:

(1) The Corporation receives a written request from the Qualified Person to be removed from the List;

(2) The Qualified Person is relocated into or has a binding lease commitment for Newly Developed Space;

(3) The Qualified Person sells, transfers, or merges its interest in the displaced business, unless after such change in ownership Qualified Persons have at least fifty-one percent of the interest in the resulting business; or

(4) The Corporation receives a mailing returned from the Post Office that the Person is not located at the known address and left no forwarding address, provided that the Corporation shall reinstate any such removed name if the Person provides the Corporation with a current address; or

(5) The Corporation ceases operations upon completion of the Plan.

(b) A Qualified person relocated into newly developed space, may only again be placed on the List:

(1) If another branch of its business is subsequently displaced from space within the Development Area which is not Newly Developed Space; and

(2) If all requirements of §908.10 of the rule are met with regard to the subsequent displacement.

### § 908.13 Rights of Qualified Persons.

(a) As provided in §§908.14(c) and 908.15(b), each Qualified Person on the List shall receive notices of opportunities to occupy Newly Developed Space as opportunities become available.

(b) As provided in §§908.14(d) and 908.15(c), each Qualified Person on the List shall be notified of any subsequent changes in the leasing plan which are, in the Corporation's opinion, major.

(c) Each Qualified Person on the List, who is interested in negotiating for occupancy of Newly Developed Space shall, within two weeks after receiving notice of a tenancing opportunity, provide written notice of its interest in the tenancing opportunity to the Developer, and furnish a copy of the written notice to the Corporation.

(d) Each Qualified Person on the List who provides a written notice of interest shall have ninety days following the Developer's receipt of the notice of interest for exclusive negotiations with the Developer for occupancy of the Developer's Newly Developed Space. During the ninety day period the Developer, subject to §§908.14 and 908.15 of this rule, shall not negotiate tenanting opportunities for the same Newly Developed Space requested by the Qualified Person with other than Qualified Persons.

(e) A Qualified Person's opportunity to occupy Newly Developed Space shall not be limited to the square on which its previous location was situated but extends throughout the Development Area. Similarly, no Qualified Person has an absolute right to return to the square where previous location was situated.

(f) A Qualified Person's opportunity to occupy space may be exercised in the Development Area at any time during the Corporation's existence, but such opportunity may only be exercised within Newly Developed Space.

(g) A Qualified Person has one opportunity to occupy Newly Developed Space for each location in the Development Area from which it is displaced.

(h) The Corporation cannot assure any Qualified Person that it will be relocated to Newly Developed Space.

**§ 908.14 Requirements placed on developers that have acquired or leased real property from the Corporation.**

Developers who have acquired or leased real property from the Corporation shall:

(a) Notify the Corporation, within six months of the approval of the Developer's building permit, of its leasing plan and when it intends to begin seeking tenants. The Developer shall include at least the following in its leasing plan:

- (1) The mix of uses and estimated square footage for each use;
- (2) The rentals to be charged by type of use and location;
- (3) The terms and conditions to be included in the leases, including financial participation;

(4) The selection criteria to be used by either the Developer or its agents; and

(5) The projected completion and occupancy dates.

(b) Notify the Corporation of any changes in the Developer's leasing plan.

(c) Send registered letters to all Qualified Persons on the List notifying them that the developer is seeking tenants and advising them that they have two weeks to provide the developer with written notice of their interest and ninety days thereafter for exclusive negotiations. This letter shall include a description of the mix of uses in the project, the rentals to be charged by type of use and location, the terms and conditions to be included in leases, the projected completion and occupancy dates, and the selection criteria to be used to choose tenants. The Developer will furnish the Corporation with an enumeration of the Qualified Persons it has notified and a copy of the letter and any attachments sent.

(d) Notify in writing each Qualified Person whom the Developer has previously contacted of changes in the Developer's leasing plan which the Corporation determines are major.

(e) Provide a ninety day period for exclusive negotiations with Qualified Persons, said period to commence with the timely receipt by the Developer of the written notice of interest from the Qualified Person. During this period the Developers shall:

- (1) Negotiate tenanting opportunities only with Qualified Persons who have notified the Developer of their interest in the opportunity;
  - (2) Not seek other potential tenants or negotiate agreements to occupy the Newly Developed Space requested by Qualified Persons with anyone other than those Qualified Persons who have timely notified the Developer of their interest in the opportunity, except that a Developer may negotiate agreements with equity partners in the project who will become tenants or with prime tenants; and
  - (3) Negotiate in good faith with interested Qualified Persons and seek to accommodate them as tenants.
- (f) Report to the Corporation at the conclusion of the ninety day period of

**§ 908.15**

exclusive negotiations concerning the results of its efforts. In particular the developer shall:

(1) State the number of responses which it received from Qualified Persons;

(2) State the number of Qualified Persons with whom it has reached agreement and the name of each;

(3) State the number of Qualified Persons with whom it is still negotiating and the name of each; and

(4) Describe the Developer's negotiations with each Qualified Person including a summary of each communication between the Developer and each Qualified Person with whom agreement has not been reached, the Developer's best offer to each Qualified Person, the best offer of each Qualified Person to the Developer, and the specific reasons why any Qualified Persons did not meet the selection criteria.

(g) Report to the Corporation quarterly thereafter until the project is fully leased or there are no more Qualified Persons interested in leasing space, whichever first occurs, concerning the results of its negotiations with Qualified Persons. In particular the Developer shall state:

(1) The number of Qualified Persons with whom it has reached agreement and the name of each;

(2) The percentage of square feet of total leasable space which it has leased to Qualified Persons; and

(3) A description of the Developer's negotiations with each Qualified Person including a summary of each communication between the Developer and each Qualified Person with whom agreement has not been reached, the Developer's best offer to each Qualified Person, the best offer of each Qualified Person to the Developer, and the specific reason why the Developer determines any Qualified Person did not meet its selection criteria.

**§ 908.15 Requirements placed on developers that have not acquired or leased real property from the Corporation.**

The Corporation shall encourage Developers that do not acquire or lease real property from the Corporation to lease to Qualified Persons.

**36 CFR Ch. IX (7-1-03 Edition)**

(a) While reviewing the Developer's preliminary or final plans, the Corporation shall explore the tenanting opportunities proposed by the Developer and furnish the Developer with the List.

(b) The Corporation shall notify those Qualified Persons on the List who appear to be prospective tenants for the available tenanting opportunities of this tenanting opportunity. To the extent that such information is available to the Corporation, these notices shall specify the mix of uses in the project, the rentals to be charged by type of use and location, the terms and conditions to be included in the leases, the projected completion and occupancy dates and the selection criteria to be used in choosing tenants.

(c) The Corporation shall notify in writing each Qualified Person whom it has previously contacted of changes in the Developer's plan provided the Corporation is informed of the changes and determines the changes are major.

(d) The Corporation shall request that the Developer make every effort to lease space to Persons on the List and to report to the Corporation the names of those Qualified Persons who have reached an agreement with the Developer.

**Subpart C [Reserved]**

**Subpart D—Review Procedure**

**§ 908.30 Request for review.**

(a) Any Person aggrieved by a determination concerning placement or retention on the List or any other right under subpart B of this rule, may request that the determination be reviewed.

(b) The applicant's request for review, shall be in writing, shall state the reasons for requesting review, and shall describe the relief sought (including all information the aggrieved person believes to be relevant). The applicant's written request shall be sent to the Director of Real Estate, Pennsylvania Avenue Development Corporation, 1331 Pennsylvania Avenue, NW., Suite 1220 North, Washington, DC 20004.

[48 FR 55459, Dec. 13, 1983, as amended at 50 FR 45824, Nov. 4, 1985]

**§ 908.31 Time for filing request for review.**

Any person who files a request for review must do so within one year of the date of the determination for which review is sought.

**§ 908.32 Review procedures.**

(a) Upon receipt of a request for review, the Director of Real Estate shall compile all pertinent records maintained on the aggrieved person's application, including the following:

(1) Information on which the original determination was based, including applicable regulations;

(2) Information submitted by the applicant including the request for review and any information submitted in support of the application;

(3) Any additional information the Director of Real Estate considers relevant to a full and fair review of the application and which he obtains by request, investigation or research.

(b) The Director of Real Estate shall submit the complete file together with a summary of the facts and issues involved in the application to the Chairman of the Board of Directors of the Corporation or his or her designee (*Chairman or designee*) within 30 days of receipt of the request for review.

(c) The Chairman may either review the application or designate one or more persons from the Board of Directors or from outside the Corporation to review the claim. During review the Chairman or designee(s) may consult with the Corporation's Office of General Counsel to obtain advice on legal issues arising from the claim.

**§ 908.33 Final determination.**

(a) The Chairman or designee(s) shall make a final determination on the claim within 45 days of receipt of the file from the Director of Real Estate. The final determination shall be in the form of Findings of Fact and Conclusions of Law and shall be sent to the aggrieved person and to the Director of Real Estate.

(b) If the applicant is determined to have been aggrieved, the Director of Real Estate shall promptly take appropriate action in accordance with the final determination.

(c) A notice of the right to judicial review shall be sent to the aggrieved person with the final determination.

**PART 909—ENFORCEMENT OF NONDISCRIMINATION ON THE BASIS OF HANDICAP IN PROGRAMS OR ACTIVITIES CONDUCTED BY THE PENNSYLVANIA AVENUE DEVELOPMENT CORPORATION**

Sec.

909.101 Purpose.

909.102 Application.

909.103 Definitions.

909.104-909.109 [Reserved]

909.110 Self-evaluation.

909.111 Notice.

909.112-909.129 [Reserved]

909.130 General prohibitions against discrimination.

909.131-909.139 [Reserved]

909.140 Employment.

909.141-909.148 [Reserved]

909.149 Program accessibility: Discrimination prohibited.

909.150 Program accessibility: Existing facilities.

909.151 Program accessibility: New construction and alterations.

909.152-909.159 [Reserved]

909.160 Communications.

909.161-909.169 [Reserved]

909.170 Compliance procedures.

909.171-909.999 [Reserved]

AUTHORITY: 29 U.S.C. 794.

SOURCE: 51 FR 22896, June 23, 1986, unless otherwise noted.

**§ 909.101 Purpose.**

This part effectuates section 119 of the Rehabilitation, Comprehensive Services, and Developmental Disabilities Amendments of 1978, which amended section 504 of the Rehabilitation Act of 1973 to prohibit discrimination on the basis of handicap in programs or activities conducted by Executive agencies or the United States Postal Service.

**§ 909.102 Application.**

This part applies to all programs or activities conducted by the agency.

**§ 909.103 Definitions.**

For purposes of this part, the term—  
*Assistant Attorney General* means the Assistant Attorney General, Civil

Rights Division, United States Department of Justice.

*Auxiliary aids* means services or devices that enable persons with impaired sensory, manual, or speaking skills to have an equal opportunity to participate in, and enjoy the benefits of, programs or activities conducted by the agency. For example, auxiliary aids useful for persons with impaired vision include readers, brailled materials, audio recordings, telecommunications devices and other similar services and devices. Auxiliary aids useful for persons with impaired hearing include telephone handset amplifiers, telephones compatible with hearing aids, telecommunication devices for deaf persons (TDD's), interpreters, notetakers, written materials, and other similar services and devices.

*Complete complaint* means a written statement that contains the complainant's name and address and describes the agency's alleged discriminatory action in sufficient detail to inform the agency of the nature and date of the alleged violation of section 504. It shall be signed by the complainant or by someone authorized to do so on his or her behalf. Complaints filed on behalf of classes or third parties shall describe or identify (by name, if possible) the alleged victims of discrimination.

*Facility* means all or any portion of buildings, structures, equipment, roads, walks, parking lots, rolling stock or other conveyances, or other real or personal property.

*Handicapped person* means any person who has a physical or mental impairment that substantially limits one or more major life activities, has a record of such an impairment, or is regarded as having such an impairment.

As used in this definition, the phrase:

(1) *Physical or mental impairment* includes—

(i) Any physiological disorder or condition, cosmetic disfigurement, or anatomical loss affecting one or more of the following body systems: Neurological; musculoskeletal; special sense organs; respiratory, including speech organs; cardiovascular; reproductive; digestive; genitourinary; hemic and lymphatic; skin; and endocrine; or

(ii) Any mental or psychological disorder, such as mental retardation, or-

ganic brain syndrome, emotional or mental illness, and specific learning disabilities. The term *physical or mental impairment* includes, but is not limited to, such diseases and conditions as orthopedic, visual, speech, and hearing impairments, cerebral palsy, epilepsy, muscular dystrophy, multiple sclerosis, cancer, heart disease, diabetes, mental retardation, emotional illness, and drug addiction and alcoholism.

(2) *Major life activities* includes functions such as caring for one's self, performing manual tasks, walking, seeing, hearing, speaking, breathing, learning, and working.

(3) *Has a record of such an impairment* means has a history of, or has been misclassified as having, a mental or physical impairment that substantially limits one or more major life activities.

(4) *Is regarded as having an impairment* means—

(i) Has a physical or mental impairment that does not substantially limit major life activities but is treated by the agency as constituting such a limitation;

(ii) Has a physical or mental impairment that substantially limits major life activities only as a result of the attitudes of others toward such impairment; or

(iii) Has none of the impairments defined in paragraph (1) of this definition but is treated by the agency as having such an impairment.

*Historic preservation programs* means programs conducted by the agency that have preservation of historic properties as a primary purpose.

*Historic properties* means those properties that are listed or eligible for listing in the National Register of Historic Places or properties designated as historic under a statute of the appropriate State or local government body.

*Qualified handicapped person* means—

(1) With respect to preschool, elementary, or secondary education services provided by the agency, a handicapped person who is a member of a class of persons otherwise entitled by statute, regulation, or agency policy to receive education services from the agency.

(2) With respect to any other agency program or activity under which a person is required to perform services or

to achieve a level of accomplishment, a handicapped person who meets the essential eligibility requirements and who can achieve the purpose of the program or activity without modifications in the program or activity that the agency can demonstrate would result in a fundamental alteration in its nature;

(3) With respect to any other program or activity, a handicapped person who meets the essential eligibility requirements for participation in, or receipt of benefits from, that program or activity; and

(4) *Qualified handicapped person* is defined for purposes of employment in 29 CFR 1613.702(f), which is made applicable to this part by § 909.140.

*Section 504* means section 504 of the Rehabilitation Act of 1973 (Pub. L. 93-112, 87 Stat. 394 (29 U.S.C. 794)), as amended by the Rehabilitation Act Amendments of 1974 (Pub. L. 93-516, 88 Stat. 1617), and the Rehabilitation, Comprehensive Services, and Developmental Disabilities Amendments of 1978 (Pub. L. 95-602, 92 Stat. 2955). As used in this part, section 504 applies only to programs or activities conducted by Executive agencies and not to federally assisted programs.

*Substantial impairment* means a significant loss of the integrity of finished materials, design quality, or special character resulting from a permanent alteration.

**§§ 909.104-909.109 [Reserved]**

**§ 909.110 Self-evaluation.**

(a) The agency shall, by August 24, 1987, evaluate its current policies and practices, and the effects thereof, that do not or may not meet the requirements of this part, and, to the extent modification of any such policies and practices is required, the agency shall proceed to make the necessary modifications.

(b) The agency shall provide an opportunity to interested persons, including handicapped persons or organizations representing handicapped persons, to participate in the self-evaluation process by submitting comments (both oral and written).

(c) The agency shall, until three years following the completion of the

self-evaluation, maintain on file and make available for public inspection:

- (1) A description of areas examined and any problems identified, and
- (2) A description of any modifications made.

**§ 909.111 Notice.**

The agency shall make available to employees, applicants, participants, beneficiaries, and other interested persons such information regarding the provisions of this part and its applicability to the programs or activities conducted by the agency, and make such information available to them in such manner as the head of the agency finds necessary to apprise such persons of the protections against discrimination assured them by section 504 and this regulation.

**§§ 909.112-909.129 [Reserved]**

**§ 909.130 General prohibitions against discrimination.**

(a) No qualified handicapped person shall, on the basis of handicap, be excluded from participation in, be denied the benefits of, or otherwise be subjected to discrimination under any program or activity conducted by the agency.

(b)(1) The agency, in providing any aid, benefit, or service, may not, directly or through contractual, licensing, or other arrangements, on the basis of handicap—

(i) Deny a qualified handicapped person the opportunity to participate in or benefit from the aid, benefit, or service;

(ii) Afford a qualified handicapped person an opportunity to participate in or benefit from the aid, benefit, or service that is not equal to that afforded others;

(iii) Provide a qualified handicapped person with an aid, benefit, or service that is not as effective in affording equal opportunity to obtain the same result, to gain the same benefit, or to reach the same level of achievement as that provided to others;

(iv) Provide different or separate aid, benefits, or services to handicapped persons or to any class of handicapped persons than is provided to others unless such action is necessary to provide

**§§ 909.131-909.139**

**36 CFR Ch. IX (7-1-03 Edition)**

qualified handicapped persons with aid, benefits, or services that are as effective as those provided to others;

(v) Deny a qualified handicapped person the opportunity to participate as a member of planning or advisory boards; or

(vi) Otherwise limit a qualified handicapped person in the enjoyment of any right, privilege, advantage, or opportunity enjoyed by others receiving the aid, benefit, or service.

(2) The agency may not deny a qualified handicapped person the opportunity to participate in programs or activities that are not separate or different, despite the existence of permissibly separate or different programs or activities.

(3) The agency may not, directly or through contractual or other arrangements, utilize criteria or methods of administration the purpose or effect of which would—

(i) Subject qualified handicapped persons to discrimination on the basis of handicap; or

(ii) Defeat or substantially impair accomplishment of the objectives of a program or activity with respect to handicapped persons.

(4) The agency may not, in determining the site or location of a facility, make selections the purpose or effect of which would—

(i) Exclude handicapped persons from, deny them the benefits of, or otherwise subject them to discrimination under any program or activity conducted by the agency; or

(ii) Defeat or substantially impair the accomplishment of the objectives of a program or activity with respect to handicapped persons.

(5) The agency, in the selection of procurement contractors, may not use criteria that subject qualified handicapped persons to discrimination on the basis of handicap.

(6) The agency may not administer a licensing or certification program in a manner that subjects qualified handicapped persons to discrimination on the basis of handicap, nor may the agency establish requirements for the programs or activities of licensees or certified entities that subject qualified handicapped persons to discrimination on the basis of handicap. However, the

programs or activities of entities that are licensed or certified by the agency are not, themselves, covered by this part.

(c) The exclusion of nonhandicapped persons from the benefits of a program limited by Federal statute or Executive order to handicapped persons or the exclusion of a specific class of handicapped persons from a program limited by Federal statute or Executive order to a different class of handicapped persons is not prohibited by this part.

(d) The agency shall administer programs and activities in the most integrated setting appropriate to the needs of qualified handicapped persons.

**§§ 909.131-909.139 [Reserved]**

**§ 909.140 Employment.**

No qualified handicapped person shall, on the basis of handicap, be subjected to discrimination in employment under any program or activity conducted by the agency. The definitions, requirements, and procedures of section 501 of the Rehabilitation Act of 1973 (29 U.S.C. 791), as established by the Equal Employment Opportunity Commission in 29 CFR part 1613, shall apply to employment in federally conducted programs or activities.

**§§ 909.141-909.148 [Reserved]**

**§ 909.149 Program accessibility: Discrimination prohibited.**

Except as otherwise provided in § 909.150, no qualified handicapped person shall, because the agency's facilities are inaccessible to or unusable by handicapped persons, be denied the benefits of, be excluded from participation in, or otherwise be subjected to discrimination under any program or activity conducted by the agency.

**§ 909.150 Program accessibility: Existing facilities.**

(a) *General.* The agency shall operate each program or activity so that the program or activity, when viewed in its entirety, is readily accessible to and usable by handicapped persons. This paragraph does not—



(1) Necessarily require the agency to make each of its existing facilities accessible to and usable by handicapped persons;

(2) In the case of historic preservation programs, require the agency to take any action that would result in a substantial impairment of significant historic features of an historic property; or

(3) Require the agency to take any action that it can demonstrate would result in a fundamental alteration in the nature of a program or activity or in undue financial and administrative burdens. In those circumstances where agency personnel believe that the proposed action would fundamentally alter the program or activity or would result in undue financial and administrative burdens, the agency has the burden of proving that compliance with § 909.150(a) would result in such alteration or burdens. The decision that compliance would result in such alteration or burdens must be made by the agency head or his or her designee after considering all agency resources available for use in the funding and operation of the conducted program or activity, and must be accompanied by a written statement of the reasons for reaching that conclusion. If an action would result in such an alteration or such burdens, the agency shall take any other action that would not result in such an alteration or such burdens but would nevertheless ensure that handicapped persons receive the benefits and services of the program or activity.

(b) *Methods*—(1) *General*. The agency may comply with the requirements of this section through such means as redesign of equipment, reassignment of services to accessible buildings, assignment of aides to beneficiaries, home visits, delivery of services at alternate accessible sites, alteration of existing facilities and construction of new facilities, use of accessible rolling stock, or any other methods that result in making its programs or activities readily accessible to and usable by handicapped persons. The agency is not required to make structural changes in existing facilities where other methods are effective in achieving compliance with this section. The agency, in mak-

ing alterations to existing buildings, shall meet accessibility requirements to the extent compelled by the Architectural Barriers Act of 1968, as amended (42 U.S.C. 4151-4157), and any regulations implementing it. In choosing among available methods for meeting the requirements of this section, the agency shall give priority to those methods that offer programs and activities to qualified handicapped persons in the most integrated setting appropriate.

(2) *Historic preservation programs*. In meeting the requirements of § 909.150(a) in historic preservation programs, the agency shall give priority to methods that provide physical access to handicapped persons. In cases where a physical alteration to an historic property is not required because of § 909.150(a)(2) or (a)(3), alternative methods of achieving program accessibility include—

(i) Using audio-visual materials and devices to depict those portions of an historic property that cannot otherwise be made accessible;

(ii) Assigning persons to guide handicapped persons into or through portions of historic properties that cannot otherwise be made accessible; or

(iii) Adopting other innovative methods.

(c) *Time period for compliance*. The agency shall comply with the obligations established under this section by October 21, 1986, except that where structural changes in facilities are undertaken, such changes shall be made by August 22, 1989, but in any event as expeditiously as possible.

(d) *Transition plan*. In the event that structural changes to facilities will be undertaken to achieve program accessibility, the agency shall develop, by February 23, 1987, a transition plan setting forth the steps necessary to complete such changes. The agency shall provide an opportunity to interested persons, including handicapped persons or organizations representing handicapped persons, to participate in the development of the transition plan by submitting comments (both oral and written). A copy of the transition plan shall be made available for public inspection. The plan shall, at a minimum—

**§ 909.151**

(1) Identify physical obstacles in the agency's facilities that limit the accessibility of its programs or activities to handicapped persons;

(2) Describe in detail the methods that will be used to make the facilities accessible;

(3) Specify the schedule for taking the steps necessary to achieve compliance with this section and, if the time period of the transition plan is longer than one year, identify steps that will be taken during each year of the transition period; and

(4) Indicate the official responsible for implementation of the plan.

**§ 909.151 Program accessibility: New construction and alterations.**

Each building or part of a building that is constructed or altered by, on behalf of, or for the use of the agency shall be designed, constructed, or altered so as to be readily accessible to and usable by handicapped persons. The definitions, requirements, and standards of the Architectural Barriers Act (42 U.S.C. 4151-4157), as established in 41 CFR 101-19.600 to 101-19.607, apply to buildings covered by this section.

**§§ 909.152-909.159 [Reserved]**

**§ 909.160 Communications.**

(a) The agency shall take appropriate steps to ensure effective communication with applicants, participants, personnel of other Federal entities, and members of the public.

(1) The agency shall furnish appropriate auxiliary aids where necessary to afford a handicapped person an equal opportunity to participate in, and enjoy the benefits of, a program or activity conducted by the agency.

(i) In determining what type of auxiliary aid is necessary, the agency shall give primary consideration to the requests of the handicapped person.

(ii) The agency need not provide individually prescribed devices, readers for personal use or study, or other devices of a personal nature.

(2) Where the agency communicates with applicants and beneficiaries by telephone, telecommunication devices for deaf person (TDD's) or equally effective telecommunication systems shall be used.

**36 CFR Ch. IX (7-1-03 Edition)**

(b) The agency shall ensure that interested persons, including persons with impaired vision or hearing, can obtain information as to the existence and location of accessible services, activities, and facilities.

(c) The agency shall provide signage at a primary entrance to each of its inaccessible facilities, directing users to a location at which they can obtain information about accessible facilities. The international symbol for accessibility shall be used at each primary entrance of an accessible facility.

(d) This section does not require the agency to take any action that it can demonstrate would result in a fundamental alteration in the nature of a program or activity or in undue financial and administrative burdens. In those circumstances where agency personnel believe that the proposed action would fundamentally alter the program or activity or would result in undue financial and administrative burdens, the agency has the burden of proving that compliance with § 909.160 would result in such alteration or burdens. The decision that compliance would result in such alteration or burdens must be made by the agency head or his or her designee after considering all agency resources available for use in the funding and operation of the conducted program or activity, and must be accompanied by a written statement of the reasons for reaching that conclusion. If an action required to comply with this section would result in such an alteration or such burdens, the agency shall take any other action that would not result in such an alteration or such burdens but would nevertheless ensure that, to the maximum extent possible, handicapped persons receive the benefits and services of the program or activity.

**§§ 909.161-909.169 [Reserved]**

**§ 909.170 Compliance procedures.**

(a) Except as provided in paragraph (b) of this section, this section applies to all allegations of discrimination on the basis of handicap in programs or activities conducted by the agency.

(b) The agency shall process complaints alleging violations of section

504 with respect to employment according to the procedures established by the Equal Employment Opportunity Commission in 29 CFR part 1613 pursuant to section 501 of the Rehabilitation Act of 1973 (29 U.S.C. 791).

(c) The Executive Director shall be responsible for coordinating implementation of this section. Complaints may be sent to the General Counsel, Pennsylvania Avenue Development Corporation, 1331 Pennsylvania Avenue, NW., Suite 1220 North, Washington, DC 20004-1730.

(d) The agency shall accept and investigate all complete complaints for which it has jurisdiction. All complete complaints must be filed within 180 days of the alleged act of discrimination. The agency may extend this time period for good cause.

(e) If the agency receives a complaint over which it does not have jurisdiction, it shall promptly notify the complainant and shall make reasonable efforts to refer the complaint to the appropriate government entity.

(f) The agency shall notify the Architectural and Transportation Barriers Compliance Board upon receipt of any complaint alleging that a building or facility that is subject to the Architectural Barriers Act of 1968, as amended (42 U.S.C. 4151-4157), or section 502 of the Rehabilitation Act of 1973, as amended (29 U.S.C. 792), is not readily accessible to and usable by handicapped persons.

(g) Within 180 days of the receipt of a complete complaint for which it has jurisdiction, the agency shall notify the complainant of the results of the investigation in a letter containing—

(1) Findings of fact and conclusions of law;

(2) A description of a remedy for each violation found; and

(3) A notice of the right to appeal.

(h) Appeals of the findings of fact and conclusions of law or remedies must be filed by the complainant within 90 days of receipt from the agency of the letter required by §909.170(g). The agency may extend this time for good cause.

(i) Timely appeals shall be accepted and processed by the head of the agency.

(j) The head of the agency shall notify the complainant of the results of

the appeal within 60 days of the receipt of the request. If the head of the agency determines that additional information is needed from the complainant, he or she shall have 60 days from the date of receipt of the additional information to make his or her determination on the appeal.

(k) The time limits cited in paragraphs (g) and (j) of this section may be extended with the permission of the Assistant Attorney General.

(l) The agency may delegate its authority for conducting complaint investigations to other Federal agencies, except that the authority for making the final determination may not be delegated to another agency.

[51 FR 22894, 22896, June 23, 1986, as amended at 51 FR 22894, June 23, 1986]

§§ 909.171-909.999 [Reserved]

**PART 910—GENERAL GUIDELINES AND UNIFORM STANDARDS FOR URBAN PLANNING AND DESIGN OF DEVELOPMENT WITHIN THE PENNSYLVANIA AVENUE DEVELOPMENT AREA**

**Subpart A—General**

Sec.

910.1 Policy.

910.2 Purpose.

910.3 Program administration.

**Subpart B—Urban Planning and Design Concerns**

910.10 General.

910.11 Comprehensive urban planning and design.

910.12 Development density.

910.13 Urban design of Washington, DC.

910.14 Historic preservation.

910.15 New development design.

910.16 Land use.

910.17 Pedestrian circulation system.

910.18 Vehicular circulation and storage systems.

**Subpart C—Standards Uniformly Applicable to the Development Area**

910.30 General.

910.31 High architectural quality.

910.32 Historic preservation.

910.33 Off-street parking.

910.34 Accommodations for the physically handicapped.

910.35 Fine arts.

## §910.1

## 36 CFR Ch. IX (7-1-03 Edition)

- 910.36 Energy conservation.
- 910.37 Fire and life safety.
- 910.38 Building exterior illumination.

### Subpart D—Glossary of Terms

- 910.50 General.
- 910.51 Access.
- 910.52 Buildable area.
- 910.53 Building restriction line.
- 910.54 Build-to height.
- 910.55 Build-to line.
- 910.56 Coordinated planning area.
- 910.57 Curb-cut.
- 910.58 Development.
- 910.59 Development parcel.
- 910.60 Gross floor area.
- 910.61 Height of development.
- 910.62 The Plan.
- 910.63 Rehabilitation.
- 910.64 Replication.
- 910.65 Restoration.
- 910.66 Sidewalk setback.
- 910.67 Square guidelines.
- 910.68 Storefront.
- 910.69 Structural bay.
- 910.70 Vault.
- 910.71 Weather protection.

AUTHORITY: Sec. 6(8) Pennsylvania Avenue Development Corporation Act of 1972 (40 U.S.C. 875(8)).

SOURCE: 48 FR 36642, Aug. 23, 1982, unless otherwise noted.

### Subpart A—General

#### §910.1 Policy.

(a) The Pennsylvania Avenue Development Corporation Act of 1972, Pub. L. 92-578, October 27, 1972, (the *Act*), (40 U.S.C. 871 *et seq.*) established the Pennsylvania Avenue Development Corporation (the *Corporation*) with jurisdiction over the Pennsylvania Avenue Development Area (*Development Area*). The Development Area is generally described as an area in Washington DC, bounded by Pennsylvania Avenue, NW., on the south, East Executive Drive on the west, 3rd Street, NW., on the east, and E and F Streets, NW., on the north.

(b) Prior to creation of the Corporation, the deterioration of the Development Area had an adverse impact upon the physical, economic, and social life of Washington, DC. The Corporation was created as the vehicle to develop, maintain, and use the Development Area in a manner suitable to its ceremonial, physical, and historic relationship to the legislative and executive branches of the Federal government, to

the governmental buildings, monuments, memorials, and parks in and adjacent to that area, and to the downtown commercial core of Washington, DC. The Corporation was directed to prepare a development plan for the Development Area and to submit that plan to the United States Congress. Congress accepted that plan and directed its implementation by the Corporation. The Corporation through a broad range of statutory powers has begun this implementation process.

(c) The Pennsylvania Avenue Plan—1974, as amended (*the Plan*) is a blueprint for social, economic, and architectural rejuvenation of the Development Area. Its goal is to make the Development Area once again a relevant and contributing element of Washington, DC. With the implementation of *the Plan*, the Development Area will become a showpiece of the Nation's Capital, proudly displaying the successful joint efforts of the Corporation, other Federal and District of Columbia government agencies, and private entrepreneurs.

(d) *The Plan*, containing the goals and objectives for *development*, is supplemented by various adopted policies and programs of the Corporation. *The Plan*, in conjunction with these policies and programs, represents the basis upon which the *development* and rejuvenation of the Development Area will proceed, whether publicly or privately inspired and accomplished. These policies and programs amplify, elaborate, and refine the planning and urban design concepts expressed in *the Plan*.

#### §910.2 Purpose.

(a) Implementation of *the Plan* occurs through two component actions: public improvements construction and square development. Public improvements construction consists of implementation by the Corporation of the Public Improvements Program which is a comprehensive plan for the design and construction of public amenities in public spaces and selected thoroughfares within the Development Area. This program outlines the details of roadway and sidewalk improvements, public space configuration, and pedestrian amenities. Square development consists of design and construction of

*development* projects primarily on city blocks, known as squares, within the Development Area. These *development* projects are generally pursued by private entrepreneurs with varying degrees of participation and involvement by the Corporation, through such means as land assemblage and leasing.

(b) This part 910, together with the *Square Guidelines* applicable to the *coordinated planning area*, pertains solely to square development and specifies the controlling mechanism for implementation of *the Plan* required by Chapter Six of *the Plan*.

**§910.3 Program administration.**

(a) This part 910, together with *Square Guidelines*, described below, provides interested parties with the urban planning and design information sufficient to understand and participate in the process of square development within the Development Area.

(1) This part 910, General Guidelines and Uniform Standards for Urban Planning and Design of Development, sets forth the general planning and design goals and objectives which govern the implementation of *the Plan*, specifies standards which are uniformly applicable to all *developments* throughout the Development Area, and provides a glossary of defined terms applicable to this part as well as *Square Guidelines*.

(2) *Square Guidelines* specifies detailed urban planning and design requirements and recommendations which are applicable to each particular *coordinated planning area*, a *coordinated planning area* being a square, a portion of a square, or a combination of squares. These requirements and recommendations set forth intentions and refinements of *the Plan* in light of the identified Planning and Design Concerns specified in subpart B of this part 910. Each set of *Square Guidelines* is adopted by the Board of Directors, issued by the Chairman, and is available, upon request, at the Corporation's office.

(3) *Square Guidelines* are developed in the context of the existing environment. Several provisions in the *Square Guidelines* are, therefore, established on the basis of certain assumptions in terms of existing buildings, a particular traffic pattern and roadway configuration, a market condition for a

particular land use, etc. In the event of a major change or casualty which would render it impossible or impracticable to meet certain requirements of *Square Guidelines*, the Corporation would expect to develop and issue up-to-date *Square Guidelines*. This statement does not, of course, preclude the Corporation from issuing amendments to *Square Guidelines* from time to time on any other basis.

(b) Pursuant to section 7(b) of the Act, each proposal for *development* within the Development Area must be submitted to the Corporation to determine its consistency with *the Plan*. The Corporation's adopted development policy, entitled "Development Policies and Procedures," sets forth the process for this determination. In determining whether a *development* proposal is consistent with *the Plan*, the Corporation shall review the proposal against all adopted Corporation programs, policies, and regulations, including:

- (1) This part 910.
- (2) Square Guidelines.
- (3) Development Policies and Procedures.
- (4) Historic Preservation Plan.
- (5) Energy Guidelines.
- (6) Side Street Improvements Program.
- (7) Policy on Environmental Quality and Control (36 CFR part 907).
- (8) Pennsylvania Avenue Lighting Plan.
- (9) Public Improvements Program.
- (10) Affirmative Action Policy and Procedure (36 CFR part 906).
- (11) Policy and Procedures to Facilitate Successful Relocation of Businesses and Residents within the Pennsylvania Avenue Development Area.
- (12) All other programs, policies, and regulations that may be approved and adopted by the Board of Directors from time to time.

(c) Pursuant to the Act, Federal and District of Columbia agencies and departments may exercise such existing authority and lawful powers over urban planning and design features of *development* as are consistent with *the Plan*. No department or agency may release, modify, or depart from any feature of *the Plan* without the prior approval of the Corporation.

### Subpart B—Urban Planning and Design Concerns

#### §910.10 General.

To facilitate review of each *development* proposal in light of the identified urban planning and design goals of *the Plan*, the following urban planning and design concerns will be the basis upon which the evaluation of such proposals will be made. These concerns are also more specifically reflected in subpart C of this Rule, and in the requirements and recommendations in *Square Guidelines*.

- (a) Comprehensive planning and design;
- (b) Development density;
- (c) Urban design of Washington, DC;
- (d) Historic preservation;
- (e) New development design;
- (f) Land use;
- (g) Pedestrian circulation systems; and
- (h) Vehicular circulation and storage systems.

#### §910.11 Comprehensive urban planning and design.

(a) All new *development* is conceived as an integral part of its surroundings, which include the remainder of the Development Area, the Mall, the Federal Triangle, and the District's downtown, and should support Pennsylvania Avenue's function as a bridge between the monumental Federal core to the south and the District's downtown to the north.

(b) All *development* shall be planned and designed to accommodate the requirements and needs of historic preservation, affirmative action, business relocation, and other concerns which will affect the overall planning and design of a *development*.

(c) The design of any *development* shall take into account *the Plan's* proposed future treatment of buildings, squares, and pedestrian spaces in the immediate surrounding area.

(d) The design of any *development* shall be coordinated with the massing, architectural design, servicing, pedestrian amenities, and uses of nearby *development* as prescribed under *the Plan*.

(e) Any *development* adjacent to F Street, NW, shall be accomplished in a

manner that will strengthen F Street as a retail core of Washington, DC.

(f) Any *development* along Pennsylvania Avenue shall be designed so as to support the transformation of the Avenue into an attractive and pleasant place for residents and visitors alike, offering pleasant places to stroll, rest, sit and talk, eat, and shop.

(g) All *development* within a *coordinated planning area* shall, to the maximum extent possible, be integrated with regard to the off-street loading and servicing, pedestrian features.

#### §910.12 Development density.

(a) Land would be developed to the fullest extent appropriate in terms of uses, economics, and design so that the city's economic life and tax base can be enhanced.

(b) New *development* shall be designed to achieve maximum development density within the building envelope delineated by specific height restrictions, but shall also establish a compatible and appropriate scale for historic preservation, residential and other uses, and other urban design elements.

(c) Development density is limited by the Zoning Regulations of the District of Columbia and may be further restricted by the Corporation in specific *coordinated planning areas*, provided that any lower density would be economically feasible. Generally, *the Plan* is structured to create high density *development* west of the FBI and lower density *development* east of the FBI.

(d) The density of new *development* should bring new economic life—jobs, shopping, and business opportunities—to Pennsylvania Avenue, while also reinforcing existing activity both on the Avenue and in the adjacent downtown, both within and beyond the Development Area.

#### §910.13 Urban design of Washington, DC.

(a) Pennsylvania Avenue's unique role as the physical and symbolic link between the White House and the U.S. Capitol should be reinforced by new *development* along it.

(b) To reinforce and enrich the legacy of the L'Enfant Plan, the primary function of new *development* in the Development Area is to define open spaces and

plazas, or to reinforce vistas along major streets and thoroughfares.

**§ 910.14 Historic preservation.**

(a) The Development Area is located almost entirely within the Pennsylvania Avenue National Historic Site, which was established to preserve the exceptional values of Pennsylvania Avenue and its environs in commemorating or illustrating the history of the United States. The Pennsylvania Avenue Area achieves national historic significance because of both its ceremonial role in the life of the nation and its social and economic role in the life of the residents of Washington for more than a century.

(b) The Historic Preservation Plan of the Corporation sets forth the adopted policy of the Corporation on historic preservation and *development* within the Development Area must be consistent with this policy.

(c) New construction adjacent to historic structures will be required to take into account the qualities of the adjacent structures (with regard to height, scale, proportion, rhythm, texture, materials, architectural detail, and the amount of variety among the structures with respect to these qualities as well as style and date of erection) to ensure that these structures maintain their historic or architectural integrity, but will not necessarily be required to conform to them.

(d) Wholly new construction and new construction in conjunction with preservation will, where appropriate, take into account the historic buildings to remain, aiming for the highest quality of contemporary design, consistent with the goals and objectives of the Historic Preservation Plan.

**§ 910.15 New development design.**

(a) All new *development* shall represent the best contemporary architectural and urban planning concepts.

(b) Where new *development* includes or relates to historic or architecturally meritorious buildings which are to be preserved, the design of the new *development* should be aimed at retaining as much of the significant fabric of the Development Area as is possible consistent with the goals of *the Plan*.

**§ 910.16 Land use.**

(a) *Development* within the Development Area shall provide, and stimulate in neighboring areas, more lively and varied shopping, cultural, entertainment, and residential opportunities, as well as high quality office uses.

(b) That portion of the Development Area west of the FBI Building is designated for commercial *development*, primarily office and hotel uses with attendant retail and service uses. That portion of the Development Area east of the FBI Building is designated for *development* with residential uses, office, institutional and entertainment uses supported by service and retail uses.

(c) The kinds of uses and their location within the Development Area shall be directly related to creating a lively atmosphere and to promoting an active street life throughout the day, evening, and weekend.

(d) Introduction or expansion of retail uses shall be encouraged as both reinforcement of existing retail uses and creation of new retail activities.

(e) While recognized as important to the commercial life of any inner city, uses that do not generate lively activities are discouraged from locating along those street fronts within the Development Area which are considered major pedestrian thoroughfares.

**§ 910.17 Pedestrian circulation system.**

(a) An efficient, pleasant, and stimulating pedestrian circulation system shall be developed to link the components of the Development Area with the Mall and the city's downtown.

(b) Pedestrian circulation systems shall be designed to provide pedestrian comfort and convenience, to create more linear footage of *storefront*, to encourage recognition of the location of various METRO stops or other mass transit locations, and to link various historic and architecturally significant buildings, sites, and monuments which are scattered throughout and beyond the Historic Site.

(c) Curb cuts across the north sidewalk areas of Pennsylvania Avenue shall be prohibited in order to reinforce its importance as the major pedestrian thoroughfare of the Development Area.

**§910.18**

**36 CFR Ch. IX (7-1-03 Edition)**

**§910.18 Vehicular circulation and storage systems.**

(a) Improvement of the existing vehicular storage and circulation system is necessary in order to create the balanced transportation system called for in *the Plan*, which recognizes the need to maintain air quality, to encourage the use of mass transit, and to provide sufficient off-street parking and loading to make development economically viable.

(b) The general policies of the Corporation are as follows:

(1) To reduce impedance to traffic movement created by service vehicles by requiring well-integrated off-street loading facilities in terms of location of loading berths and access points on a block-by-block basis;

(2) To control the number of vehicles in the Development Area by limiting the number of parking spaces per *development*; and

(3) To encourage the use of public transportation by linking new *development* to transit stops through the system of pedestrian ways.

**Subpart C—Standards Uniformly Applicable to the Development Area**

**§910.30 General.**

In addition to the specific requirements and recommendations contained in *Square Guidelines* for the applicable *coordinated planning area*, the Standards set forth in this subpart C are uniformly applicable to any *development* within the Development Area.

**§910.31 High architectural quality.**

*Development* must maintain a uniformly high standard of architecture, representative of the best contemporary design and planning concepts. Great care and sensitivity must be shown in the architectural treatment of new buildings, particularly in terms of massing, facade design (including materials, composition, and detailing), the ground floor and sidewalk pedestrian environment, interior public spaces, and provisions for pedestrian and vehicular access. Special design considerations for each *coordinated*

*planning area* are set forth in *Square Guidelines*.

**§910.32 Historic preservation.**

*Rehabilitation* of buildings within the Development Area, which, according to *the Plan* and the Historic Preservation Plan of the Corporation, are specified for preservation, shall be accomplished (a) in accordance with the Secretary of the Interior's "Standards for Historic Preservation Projects": (36 CFR part 68), and (b) consultation with the State Historic Preservation Officer for the District of Columbia.

**§910.33 Off-street parking.**

(a) Off-street parking as a principal use is prohibited, although off-street parking as an accessory use in a *development* (such as a below-grade parking garage) is permitted.

(b) All parking spaces shall be located below grade level.

(c) The minimum number of parking spaces shall be provided in accordance with DC Zoning Regulations.

(d) The maximum number of parking spaces permitted by PADC for a *development* may not exceed the aggregate of the number of spaces allowed for each use within the *development*. The schedule of limitations for parking spaces is as follows:

(1) Hotel: One parking space for each four sleeping rooms or suites;

(2) Places of public assemblage other than hotels: (i.e., arena, armory, theater, auditorium, community center, convention center, concert hall, etc.) one parking space for each ten seats of occupancy capacity for the first 10,000 seats plus one for each 20 seats above 10,000: Provided, that where seats are not fixed, each seven square feet of *gross floor area* usable for seating shall be considered one seat;

(3) Retail, trade, and service establishments: one parking space for each 750 square feet of *gross floor area*;

(4) Residential: One parking space for each 1.2 units;

(5) Offices: One parking space for each 1,800 square feet of *gross floor area*.



**§ 910.34 Accommodations for the physically handicapped.**

(a) Every *development* shall incorporate features which will make the *development* accessible by the physically handicapped. The standards in the "American Standard Specifications for Making Buildings and Facilities Accessible to, and Usable by the Physically Handicapped," published by the American National Standards Institute, Inc. (ANSI A 117.1-1961 (1971)), are recommended.

(b) Where a *development* includes a historic structure, the Advisory Council on Historic Preservation's policy, "Supplementary Guidance—Handicapped Access to Historic Properties," (45 FR 9757, Feb. 13, 1980), should be observed.

**§ 910.35 Fine arts.**

Fine arts, including sculpture, paintings, decorative windows, bas-reliefs, ornamental fountains, murals, tapestries, and the like, should be included in each *development*. PADC encourages commissions for original works of art which are appropriate for the *development*. For information and guidance, a reasonable expenditure for fine arts is deemed to be one half of one percent of the total construction cost of the *development*.

**§ 910.36 Energy conservation.**

All new *development* shall be designed to be economical in energy consumption. The Energy Guidelines of the Corporation, and the District of Columbia Energy Conservation Code Act of 1979 and its implementing regulations set forth the appropriate standards to be observed.

**§ 910.37 Fire and life safety.**

As a complementary action to satisfying required District of Columbia codes related to fire safety, it is highly recommended that all new *development* be guided by standards of the NFPA Codes for fire and life safety and that all buildings be equipped with an approved sprinkler system.

**§ 910.38 Building exterior illumination.**

Exterior illumination of a building shall be in conformance with the stand-

ards specified in the Pennsylvania Avenue Lighting Plan of the Corporation.

**Subpart D—Glossary of Terms**

**§ 910.50 General.**

The definitions appearing in this Glossary of Terms are applicable to this part 910 and to the *Square Guidelines*. In addition, definitions appearing in section 1201 of the Zoning Regulations of the District of Columbia are also applicable. Where a conflict between this subpart and section 1201 of the Zoning Regulations arises in terminology or interpretation, this subpart shall be controlling.

**§ 910.51 Access.**

*Access*, when used in reference to parking or loading, means both ingress and egress.

**§ 910.52 Buildable area.**

*Buildable area* means that portion of the established *development parcel* which can be devoted to buildings and structures. Generally, this area is bounded by any applicable *building restriction lines*, right-of-way lines and *development parcel lines*. It shall be the *buildable area* of a *development parcel* rather than "lot," as it is established in the DC Zoning Regulations, that will be utilized to establish the maximum *gross floor area* of a *development* within specified portions of the Development Area.

**§ 910.53 Building restriction line.**

*Building restriction line* means a line beyond which an exterior wall of any building of a *development* may not be constructed or project, except that architectural articulation, minor architectural embellishments, and sub-surface projections are permitted.

**§ 910.54 Build-to height.**

*Build-to height* means a specified minimum *height of development* to which the exterior wall of a building in a *development* must rise. Minor deviations from the *build-to height* for architectural embellishments and articulations of the cornice and roof level are permitted, unless otherwise prohibited by the applicable Square Guidelines or the

## §910.55

District of Columbia's codes and regulations.

### §910.55 Build-to line.

*Build-to line* means a line with which the exterior wall of a building in a *development* is required to coincide. Minor deviations from the *build-to line* for such architectural features as *weather protection*, recesses, niches, ornamental projections, entrance bays, or other articulations of the facade are permitted, unless otherwise prohibited by the applicable *Square Guidelines* or the District of Columbia's codes and regulations.

### §910.56 Coordinated planning area.

*Coordinated planning area* means a Square, portion of a Square, or group of Squares that is composed of one or more *development parcels* and is treated as a unit under *Square Guidelines* in order to achieve comprehensive planning and design.

### §910.57 Curb-cut.

*Curb-cut* means that portion of the curb and sidewalk over which vehicular *access* is allowed. The number of *access lanes* for each *curb-cut* shall be specified in each set of *Square Guidelines*.

### §910.58 Development.

*Development* means a structure, including a building, planned unit development, or project resulting from the process of planning, land acquisition, demolition, construction, or *rehabilitation* consistent with the objectives and goals of *the Plan*.

### §910.59 Development parcel.

*Development parcel* means an area of land established by the Corporation to be a minimum site on which a *development* may occur under *the Plan* and any applicable *Square Guidelines* adopted by the Corporation. A *development parcel* does not need to be under the ownership of a single individual or entity. A proposal for a *development parcel* may be formulated by any number of individuals or entities, so long as it accommodates the needs and requirements of affirmative action, historic preservation and other policies of the Corporation, and at the same time responds to the goals of comprehensive planning

## 36 CFR Ch. IX (7-1-03 Edition)

and design for that particular *coordinated planning area*.

### §910.60 Gross floor area.

*Gross floor area* is defined in section 1201, Zoning Regulations of the District of Columbia and generally means the sum of the gross horizontal areas of the several floors from the ground floor up of all buildings of a *development* occurring on a lot. *Gross floor area* shall be measured from the exterior faces of exterior walls and from the center line of walls separating two buildings.

### §910.61 Height of development.

*Height of development* means the vertical distance measured from a specified point at the curb level to the highest point of the roof or parapet of the *development*, whichever is higher, exclusive of all *roof structures* except as otherwise specified.

### §910.62 The Plan.

*The Plan* means The Pennsylvania Avenue Plan—1974, as amended, and prepared pursuant to Pub. L. 92-578, 86 Stat. 1266 (40 U.S.C. 871), and the document which sets forth the *development* concepts upon which this part 910 and *Square Guidelines* are based.

### §910.63 Rehabilitation.

*Rehabilitation* means the process of adapting improvements on real property to make possible an efficient contemporary use achieved by means of a combination of construction, repair, or alteration, as well as *restoration* and *replication* of those portions and features of the property that are significant to its historic, architectural, and cultural values, consistent with the goals and objectives of *the Plan*.

### §910.64 Replication.

*Replication* means the process of using modern methods and materials to reproduce the exact form and details of a vanished building, structure, object, or portion thereof, as it appeared at a particular period of time, and consistent with the objectives and goals of *the Plan*.

**§ 910.65 Restoration.**

*Restoration* means the process of accurately recovering the form and details of a property as they appeared at a particular period of time by means of removal of later work and the replacement of missing original work, consistent with the objectives and goals of the *Plan*.

**§ 910.66 Sidewalk setback.**

*Sidewalk setback* means that area between a *building restriction line* and the right-of-way of a street into which projections except architectural articulations, minor architectural embellishments, and subsurface structures, are prohibited. The area is to be dedicated to open space activities related to the public improvements program of the Pennsylvania Avenue Development Corporation. Subsurface structures may intrude into the area if they are in compliance with the *Square Guidelines*.

**§ 910.67 Square guidelines.**

*Square Guidelines* establish the Corporation's specific intent with regard to design and development objectives

relative to each individual *coordinated planning area*.

**§ 910.68 Storefront.**

*Storefront* means the street level frontage relating to a single establishment.

**§ 910.69 Structural bay.**

*Structural bay* means the distance or span from one vertical structural member fronting on a street to the immediately adjacent vertical structural member fronting on the same street.

**§ 910.70 Vault.**

A *vault* means an enclosure of space beneath the surface of the public space or *sidewalk setback*, except that the term *vault* shall not include public utility structures.

**§ 910.71 Weather protection.**

*Weather protection* means a seasonal or permanent shelter to protect pedestrians from sun or precipitation, consisting of arcades, canopies, awnings, or other coverings.

**PARTS 911-999 [RESERVED]**



## CHAPTER X—PRESIDIO TRUST

---

<i>Part</i>		<i>Page</i>
1001	General provisions .....	217
1002	Resource protection, public use and recreation .....	222
1004	Vehicles and traffic safety .....	235
1005	Commercial and private operations .....	239
1007	Requests under the Freedom of Information Act ....	242
1008	Requests under the Privacy Act .....	251
1009	Administrative claims under the Federal Tort Claims Act .....	260
1010	Environmental quality .....	261



## PART 1001—GENERAL PROVISIONS

- Sec.  
1001.1 Purpose.  
1001.2 Applicability and scope.  
1001.3 Penalties.  
1001.4 Definitions.  
1001.5 Closures and public use limits.  
1001.6 Permits.  
1001.7 Public notice.  
1001.8 Information collection.  
1001.10 Symbolic signs.

AUTHORITY: Pub. L. 104-333, 110 Stat. 4097 (16 U.S.C. 460bb note).

SOURCE: 63 FR 35697, June 30, 1998, unless otherwise noted.

### § 1001.1 Purpose.

(a) The regulations in this chapter provide for the proper use, management, government and protection of persons, property and natural and cultural resources within the area under the jurisdiction of the Presidio Trust.

(b) The regulations in this chapter will be utilized to fulfill the statutory purposes of the Presidio Trust Act.

### § 1001.2 Applicability and scope.

(a) The regulations contained in this chapter apply to all persons entering, using, visiting, or otherwise within the boundaries of federally owned lands and waters administered by the Presidio Trust.

(b) The regulations contained in Parts 1002, 1004 and 1005 of this chapter shall not be construed to prohibit administrative activities conducted by the Presidio Trust, or its agents, in accordance with approved policies of the Presidio Trust, or in emergency operations involving threats to life, property, or resources of the area administered by the Presidio Trust.

(c) The regulations in this chapter are intended to treat a mobility-impaired person using a manual or motorized wheelchair as a pedestrian and are not intended to restrict the activities of such a person beyond the degree that the activities of a pedestrian are restricted by the same regulations.

### § 1001.3 Penalties.

A person convicted of violating a provision of the regulations contained in Parts 1001, 1002, 1004 and 1005 of this chapter, within the area administered

by the Presidio Trust, shall be punished by a fine as provided by law, or by imprisonment not exceeding 6 months, or both, and shall be adjudged to pay all costs of the proceedings.

### § 1001.4 Definitions.

The following definitions shall apply to this chapter, unless modified by the definitions for a specific part or regulation:

*Abandonment* means the voluntary relinquishment of property with no intent to retain possession.

*Administrative activities* means those activities conducted under the authority of the Presidio Trust for the purpose of safeguarding persons or property, implementing management plans and policies developed in accordance and consistent with the regulations in this chapter, or repairing or maintaining government facilities.

*Airboat* means a vessel that is supported by the buoyancy of its hull and powered by a propeller or fan above the waterline. This definition should not be construed to mean a "hovercraft," that is supported by a fan-generated air cushion.

*Aircraft* means a device that is used or intended to be used for human flight in the air, including powerless flight.

*Archeological resource* means material remains of past human life or activities that are of archeological interest and are at least 50 years of age. This term includes, but shall not be limited to, objects made or used by humans, such as pottery, basketry, bottles, weapons, weapon projectiles, tools, structures or portions of structures, pit houses, rock paintings, rock carvings, intaglios, or any portion or piece of the foregoing items, and the physical site, location or context in which they are found, or human skeletal materials or graves.

*Authorized emergency vehicle* means a vehicle in official use for emergency purposes by a Federal agency or an emergency vehicle as defined by State law.

*Authorized person* means an employee or agent of the Presidio Trust with delegated authority to enforce the provisions of this chapter.

*Bicycle* means every device propelled solely by human power upon which a

#### § 1001.4

person or persons may ride on land, having one, two, or more wheels, except a manual wheelchair.

*Board* means the Board of Directors of the Presidio Trust or its designee.

*Boundary* means the limits of lands or waters administered by the Presidio Trust as specified by Congress, or denoted by presidential proclamation, or recorded in the records of a state or political subdivision in accordance with applicable law, or published pursuant to law, or otherwise published or posted by the Presidio Trust.

*Camping* means the erecting of a tent or shelter of natural or synthetic material, preparing a sleeping bag or other bedding material for use, parking of a motor vehicle, motor home or trailer, or mooring of a vessel for the apparent purpose of overnight occupancy.

*Carry* means to wear, bear, or have on or about the person.

*Controlled substance* means a drug or other substance, or immediate precursor, included in schedules I, II, III, IV, or V of part B of the Controlled Substance Act (21 U.S.C. 812) or a drug or substance added to these schedules pursuant to the terms of the Act.

*Cultural resource* means material remains of past human life or activities that are of significant cultural interest and are less than 50 years of age. This term includes, but shall not be limited to, objects made or used by humans, such as pottery, basketry, bottles, weapons, weapon projectiles, tools, structures or portions of structures, or any portion or piece of the foregoing items, and the physical site, location, or context in which they are found, or human skeletal materials or graves.

*Developed area* means roads, parking areas, picnic areas, campgrounds, or other structures, facilities or lands located within development and historic zones depicted on the land management and use map for the area administered by the Presidio Trust.

*Downed aircraft* means an aircraft that cannot become airborne as a result of mechanical failure, fire, or accident.

*Executive Director* means the Executive Director of the Presidio Trust or his or her designee.

*Firearm* means a loaded or unloaded pistol, rifle, shotgun or other weapon

#### 36 CFR Ch. X (7-1-03 Edition)

which is designed to, or may be readily converted to, expel a projectile by the ignition of a propellant.

*Fish* means any member of the subclasses Agnatha, Chondrichthyes, or Osteichthyes, or any mollusk or crustacean found in salt water.

*Fishing* means taking or attempting to take fish.

*Hunting* means taking or attempting to take wildlife, except trapping.

*Legislative jurisdiction* means lands and waters under the exclusive or concurrent jurisdiction of the United States.

*Manual wheelchair* means a device that is propelled by human power, designed for and used by a mobility-impaired person.

*Motor vehicle* means every vehicle that is self-propelled and every vehicle that is propelled by electric power, but not operated on rails or upon water, except a snowmobile and a motorized wheelchair.

*Motorcycle* means every motor vehicle having a seat for the use of the rider and designed to travel on not more than three wheels in contact with the ground, but excluding a tractor.

*Motorized wheelchair* means a self-propelled wheeled device, designed solely for and used by a mobility-impaired person for locomotion, that is both capable of and suitable for use in indoor pedestrian areas.

*Net* means a seine, weir, net wire, fish trap, or other implement designed to entrap fish, except a hand-held landing net used to retrieve fish taken by hook and line.

*Nondeveloped area* means all lands and waters within the area administered by the Presidio Trust other than developed areas.

*Operator* means a person who operates, drives, controls, otherwise has charge of or is in actual physical control of a mechanical mode of transportation or any other mechanical equipment.

*Pack animal* means horses, burros, mules or other hoofed mammals when designated as pack animals by the Executive Director.

*Permit* means a written authorization to engage in uses or activities that are otherwise prohibited, restricted, or regulated.



## Presidio Trust

## § 1001.4

*Person* means an individual, firm, corporation, society, association, partnership, or private or public body.

*Pet* means a dog, cat or any animal that has been domesticated.

*Possession* means exercising direct physical control or dominion, with or without ownership, over property, or archeological, cultural or natural resources.

*Practitioner* means a physician, dentist, veterinarian, scientific investigator, pharmacy, hospital or other person licensed, registered or otherwise permitted by the United States or the jurisdiction in which such person practices to distribute or possess a controlled substance in the course of professional practice.

*Presidio Trust* and *Trust* mean the wholly-owned federal government corporation created by the Presidio Trust Act.

*Presidio Trust Act* means Title I of Public Law 104-333, 110 Stat. 4097, as the same may be amended.

*Presidio Trust road* means the main-traveled surface of a roadway open to motor vehicles, owned, controlled or otherwise administered by the Presidio Trust.

*Printed matter* means message-bearing textual printed material such as books, pamphlets, magazines and leaflets and does not include other forms of merchandise, such as posters, coffee mugs, sunglasses, audio or videotapes, T-shirts, hats, ties, shorts and other clothing articles.

*Public use limit* means the number of persons; number and type of animals; amount, size and type of equipment, vessels, mechanical modes of conveyance, or food/beverage containers allowed to enter, be brought into, remain in, or be used within a designated geographic area or facility; or the length of time a designated geographic area or facility may be occupied.

*Refuse* means trash, garbage, rubbish, waste papers, bottles or cans, debris, litter, oil, solvents, liquid waste, or other discarded materials.

*Services* means, but is not limited to, meals and lodging, labor, professional services, transportation, admission to exhibits, use of telephone or other utilities, or any act for which payment is customarily received.

*Smoking* means the carrying of lighted cigarettes, cigars or pipes, or the intentional and direct inhalation of smoke from these objects.

*Snowmobile* means a self-propelled vehicle intended for travel primarily on snow, having a curb weight of not more than 1000 pounds (450 kg), driven by a track or tracks in contact with the snow, and steered by a ski or skis in contact with the snow.

*State* means a State, territory, or possession of the United States.

*State law* means the applicable and nonconflicting laws, statutes, regulations, ordinances, infractions and codes of the State(s) and political subdivision(s) within whose exterior boundaries the area administered by the Presidio Trust or a portion thereof is located.

*Take* or *taking* means to pursue, hunt, harass, harm, shoot, trap, net, capture, collect, kill, wound, or attempt to do any of the aforementioned.

*Traffic* means pedestrians, ridden or herded animals, vehicles and other conveyances, either singly or together while using any road, trail, street or other thoroughfare for purpose of travel.

*Traffic control device* means a sign, signal, marking or other device placed or erected by, or with the concurrence of, the Executive Director for the purpose of regulating, warning, guiding or otherwise controlling traffic or regulating the parking of vehicles.

*Trap* means a snare, trap, mesh, wire or other implement, object or mechanical device designed to entrap or kill animals other than fish.

*Trapping* means taking or attempting to take wildlife with a trap.

*Underway* means when a vessel is not at anchor, moored, made fast to the shore or docking facility, or aground.

*Unloaded*, as applied to weapons and firearms, means that:

(1) There is no unexpended shell, cartridge, or projectile in any chamber or cylinder of a firearm or in a clip or magazine inserted in or attached to a firearm;

(2) A muzzle-loading weapon does not contain gun powder in the pan, or the percussion cap is not in place; and

(3) Bows, crossbows, spear guns or any implement capable of discharging

## § 1001.5

## 36 CFR Ch. X (7-1-03 Edition)

a missile or similar device by means of a loading or discharging mechanism, when that loading or discharging mechanism is not charged or drawn.

*Vehicle* means every device in, upon, or by which a person or property is or may be transported or drawn on land, except snowmobiles and devices moved by human power or used exclusively upon stationary rails or track.

*Vessel* means every type or description of craft, other than a seaplane on the water, used or capable of being used as a means of transportation on water, including a buoyant device permitting or capable of free flotation.

*Weapon* means a firearm, compressed gas or spring-powered pistol or rifle, bow and arrow, crossbow, blowgun, speargun, hand-thrown spear, sling-shot, irritant gas device, explosive device, or any other implement designed to discharge missiles, and includes a weapon the possession of which is prohibited under the laws of the State in which the area administered by the Presidio Trust or portion thereof is located.

*Wildlife* means any member of the animal kingdom and includes a part, product, egg or offspring thereof, or the dead body or part thereof, except fish.

### § 1001.5 Closures and public use limits.

(a) Consistent with applicable legislation and Federal administrative policies, and based upon a determination that such action is necessary for the maintenance of public health and safety, protection of environmental or scenic values, protection of natural or cultural resources, aid to scientific research, implementation of management responsibilities, equitable allocation and use of facilities, or the avoidance of conflict among visitor use activities, the Board may:

(1) Establish, for all or a portion of the area administered by the Presidio Trust, a reasonable schedule of visiting hours, impose public use limits, or close all or a portion of the area administered by the Presidio Trust to all public use or to a specific use or activity.

(2) Designate areas for a specific use or activity, or impose conditions or restrictions on a use or activity.

(3) Terminate a restriction, limit, closure, designation, condition, or visiting hour restriction imposed under paragraph (a)(1) or (2) of this section.

(b) Except in emergency situations, a closure, designation, use or activity restriction or condition, or the termination or relaxation of such, which is of a nature, magnitude and duration that will result in a significant alteration in the public use pattern of the area administered by the Presidio Trust, adversely affect the natural, aesthetic, scenic or cultural values of the area administered by the Presidio Trust, require a long-term or significant modification in the resource management objectives of the area administered by the Presidio Trust, or is of a highly controversial nature, shall be published as rulemaking in the FEDERAL REGISTER.

(c) Except in emergency situations, prior to implementing or terminating a restriction, condition, public use limit or closure, the Board shall prepare a written determination justifying the action. That determination shall set forth the reason(s) the restriction, condition, public use limit or closure authorized by paragraph (a) of this section has been established, and an explanation of why less restrictive measures will not suffice, or in the case of a termination of a restriction, condition, public use limit or closure previously established under paragraph (a) of this section, a determination as to why the restriction is no longer necessary and a finding that the termination will not adversely impact resources of the area administered by the Presidio Trust. This determination shall be available to the public upon request.

(d) To implement a public use limit, the Board may establish a permit, registration, or reservation system. Permits shall be issued in accordance with the criteria and procedures of § 1001.6.

(e) Except in emergency situations, the public will be informed of closures, designations, and use or activity restrictions or conditions, visiting hours, public use limits, public use limit procedures, and the termination or relaxation of such, in accordance with § 1001.7.

(f) Violating a closure, designation, use or activity restriction or condition,

## Presidio Trust

schedule of visiting hours, or public use limit is prohibited.

### § 1001.6 Permits.

(a) When authorized by regulations set forth in this chapter, the Executive Director may issue a permit to authorize an otherwise prohibited or restricted activity or impose a public use limit. The activity authorized by a permit shall be consistent with applicable legislation, Federal regulations and administrative policies, and based upon a determination that public health and safety, environmental or scenic values, natural or cultural resources, scientific research, implementation of management responsibilities, proper allocation and use of facilities, or the avoidance of conflict among visitor use activities will not be adversely impacted.

(b) Except as otherwise provided, application for a permit shall be submitted to the Executive Director during normal business hours.

(c) The public will be informed of the existence of a permit requirement in accordance with § 1001.7.

(d) Unless otherwise provided for by the regulations in this chapter, the Executive Director shall deny a permit that has been properly applied for only upon a determination that the designated capacity for an area or facility would be exceeded; or that one or more of the factors set forth in paragraph (a) of this section would be adversely impacted. The basis for denial shall be provided to the applicant upon request.

(e) The Executive Director shall include in a permit the terms and conditions that the Executive Director deems necessary to protect resources of the area administered by the Presidio Trust or public safety and may also include terms or conditions established pursuant to the authority of any other section of this chapter.

(f) A compilation of those activities requiring a permit shall be maintained by the Executive Director and available to the public upon request.

(g) The following are prohibited:

(1) Engaging in an activity subject to a permit requirement imposed pursuant to this section without obtaining a permit; or

(2) Violating a term or condition of a permit issued pursuant to this section.

## § 1001.8

(h) Violating a term or condition of a permit issued pursuant to this section may also result in the suspension or revocation of the permit by the Executive Director.

### § 1001.7 Public notice.

(a) Whenever the authority of § 1001.5(a) is invoked to restrict or control a public use or activity, to relax or revoke an existing restriction or control, to designate all or a portion of the area administered by the Presidio Trust as open or closed, or to require a permit to implement a public use limit, the public shall be notified by one or more of the following methods:

(1) Signs posted at conspicuous locations, such as normal points of entry and reasonable intervals along the boundary of the affected locale.

(2) Maps available in the office of the Presidio Trust and other places convenient to the public.

(3) Publication in a newspaper of general circulation in the affected area.

(4) Other appropriate methods, such as the removal of closure signs, use of electronic media, brochures, maps and handouts.

(b) In addition to the above-described notification procedures, the Board shall compile in writing all the designations, closures, permit requirements and other restrictions imposed under discretionary authority. This compilation shall be updated annually and made available to the public upon request.

### § 1001.8 Information collection.

The information collection requirements contained in 36 CFR 1001.5, 1002.5, 1002.10, 1002.12, 1002.17, 1002.33, 1002.38, 1002.50, 1002.51, 1002.52, 1002.60, 1002.61, 1002.62, 1004.4 and 1004.11 have been approved by the Office of Management and Budget under 44 U.S.C. 3501 *et seq.*, and assigned clearance number 1024-0026. This information is being collected to provide the Executive Director data necessary to issue permits for special uses of the area administered by the Presidio Trust and to obtain notification of accidents that occur within the area administered by the Presidio Trust. This information will be used to grant administrative benefits

## § 1001.10

and to facilitate prompt emergency response to accidents. In 36 CFR 1002.33 and 1004.4, the obligation to respond is mandatory; in all other sections the obligation to respond is required in order to obtain a benefit.

### § 1001.10 Symbolic signs.

(a) The signs pictured in 36 CFR 1.10 provide general information and regulatory guidance in the area administered by the Presidio Trust. Certain of the signs designate activities that are either allowed or prohibited. Activities symbolized by a sign bearing a slash mark are prohibited.

(b) The use of other types of signs not herein depicted is not precluded.

## PART 1002—RESOURCE PROTECTION, PUBLIC USE AND RECREATION

Sec.

- 1002.1 Preservation of natural, cultural and archeological resources.
- 1002.2 Wildlife protection.
- 1002.3 Fishing.
- 1002.4 Weapons, traps and nets.
- 1002.5 Research specimens.
- 1002.10 Camping and food storage.
- 1002.11 Picnicking.
- 1002.12 Audio disturbances.
- 1002.13 Fires.
- 1002.14 Sanitation and refuse.
- 1002.15 Pets.
- 1002.16 Horses and pack animals.
- 1002.17 Aircraft and air delivery.
- 1002.18 Snowmobiles.
- 1002.19 Winter activities.
- 1002.20 Skating, skateboards and similar devices.
- 1002.21 Smoking.
- 1002.22 Property.
- 1002.23 Recreation fees.
- 1002.30 Misappropriation of property and services.
- 1002.31 Trespassing, tampering and vandalism.
- 1002.32 Interfering with agency functions.
- 1002.33 Report of injury or damage.
- 1002.34 Disorderly conduct.
- 1002.35 Alcoholic beverages and controlled substances.
- 1002.36 Gambling.
- 1002.37 Noncommercial soliciting.
- 1002.38 Explosives.
- 1002.50 Special events.
- 1002.51 Public assemblies, meetings.
- 1002.52 Sale or distribution of printed matter.
- 1002.60 Livestock use and agriculture.
- 1002.61 Residing on Federal lands.

## 36 CFR Ch. X (7-1-03 Edition)

1002.62 Memorialization.

1002.63 Boating and water use activities.

AUTHORITY: Pub. L. 104-333, 110 Stat. 4097 (16 U.S.C. 460bb note).

SOURCE: 63 FR 35700, June 30, 1998, unless otherwise noted.

### § 1002.1 Preservation of natural, cultural and archeological resources.

(a) Except as otherwise provided in this chapter, the following is prohibited:

(1) Possessing, destroying, injuring, defacing, removing, digging, or disturbing from its natural state:

(i) Living or dead wildlife or fish, or the parts or products thereof, such as antlers or nests.

(ii) Plants or the parts or products thereof.

(iii) Nonfossilized and fossilized paleontological specimens, cultural or archeological resources, or the parts thereof.

(iv) A mineral resource or cave formation or the parts thereof.

(2) Introducing wildlife, fish or plants, including their reproductive bodies, into an ecosystem within the area administered by the Presidio Trust.

(3) Tossing, throwing or rolling rocks or other items inside caves or caverns, into valleys, canyons, or caverns, down hillsides or mountainsides, or into thermal features.

(4) Using or possessing wood gathered from within the area administered by the Presidio Trust: Provided, however, that the Board may designate areas where dead wood on the ground may be collected for use as fuel for campfires within the area administered by the Presidio Trust.

(5) Walking on, climbing, entering, ascending, descending, or traversing an archeological or cultural resource, monument, or statue, except in designated areas and under conditions established by the Board.

(6) Possessing, destroying, injuring, defacing, removing, digging, or disturbing a structure or its furnishing or fixtures, or other cultural or archeological resources.

(7) Possessing or using a mineral or metal detector, magnetometer, side

## Presidio Trust

scan sonar, other metal detecting device, or subbottom profiler. This paragraph does not apply to:

(i) A device broken down and stored or packed to prevent its use while in the area administered by the Presidio Trust.

(ii) Electronic equipment used primarily for the navigation and safe operation of boats and aircraft.

(iii) Mineral or metal detectors, magnetometers, or subbottom profilers used for authorized scientific, mining, or administrative activities.

(b) The Board may restrict hiking or pedestrian use to a designated trail or walkway system pursuant to §§1001.5 and 1001.7 of this chapter. Leaving a trail or walkway to shortcut between portions of the same trail or walkway, or to shortcut to an adjacent trail or walkway in violation of designated restrictions is prohibited.

(c)(1) The Board may designate certain fruits, berries, nuts, or unoccupied seashells which may be gathered by hand for personal use or consumption upon a written determination that the gathering or consumption will not adversely affect wildlife, the reproductive potential of a plant species, or otherwise adversely affect the resources of the area administered by the Presidio Trust.

(2) The Board may:

(i) Limit the size and quantity of the natural products that may be gathered or possessed for this purpose; or

(ii) Limit the location where natural products may be gathered; or

(iii) Restrict the possession and consumption of natural products to the area administered by the Presidio Trust.

(3) The following are prohibited:

(i) Gathering or possessing undesignated natural products.

(ii) Gathering or possessing natural products in violation of the size or quantity limits designated by the Board.

(iii) Unauthorized removal of natural products from the area administered by the Presidio Trust.

(iv) Gathering natural products outside of designated areas.

(v) Sale or commercial use of natural products.

## § 1002.4

(d) This section shall not be construed as authorizing the taking, use or possession of fish, wildlife or plants for ceremonial or religious purposes, except where specifically authorized by Federal statutory law, treaty rights, or in accordance with § 1002.2 or § 1002.3.

### § 1002.2 Wildlife protection.

(a) The following are prohibited:

(1) The taking of wildlife.

(2) The feeding, touching, teasing, frightening or intentional disturbing of wildlife nesting, breeding or other activities.

(3) Possessing unlawfully taken wildlife or portions thereof.

(b) *Hunting and trapping.* Hunting and trapping are prohibited within the area administered by the Presidio Trust.

(c) The Board may establish conditions and procedures for transporting lawfully taken wildlife through the area administered by the Presidio Trust. Violation of these conditions and procedures is prohibited.

(d) The Board may designate all or portions of the area administered by the Presidio Trust as closed to the viewing of wildlife with an artificial light. Use of an artificial light for purposes of viewing wildlife in closed areas is prohibited.

(e) The regulations contained in this section apply, regardless of land ownership, on all lands and waters within the boundaries of the area administered by the Presidio Trust that are under the legislative jurisdiction of the United States.

### § 1002.3 Fishing.

Fishing is prohibited within the area administered by the Presidio Trust.

### § 1002.4 Weapons, traps and nets.

(a)(1) Except as otherwise provided in this section, the following are prohibited:

(i) Possessing a weapon, trap or net.

(ii) Carrying a weapon, trap or net.

(iii) Using a weapon, trap or net.

(2) Weapons, traps or nets may be carried, possessed or used:

(i) At designated times and locations in the area administered by the Presidio Trust where:

(A) The taking of wildlife is authorized by law in accordance with § 1002.2;

## § 1002.5

## 36 CFR Ch. X (7-1-03 Edition)

(B) The taking of fish is authorized by law in accordance with § 1002.3.

(ii) Within a residential dwelling. For purposes of this paragraph only, the term "residential dwelling" means a fixed housing structure which is either the principal residence of its occupants, or is occupied on a regular and recurring basis by its occupants as an alternate residence or vacation home.

(3) Traps, nets and unloaded weapons may be possessed within a temporary lodging or mechanical mode of conveyance when such implements are rendered temporarily inoperable or are packed, cased or stored in a manner that will prevent their ready use.

(b) Carrying or possessing a loaded weapon in a motor vehicle, vessel or other mode of transportation is prohibited, except that carrying or possessing a loaded weapon in a vessel is allowed when such vessel is not being propelled by machinery and is used as a shooting platform in accordance with Federal and State law.

(c) The use of a weapon, trap or net in a manner that endangers persons or property is prohibited.

(d) Authorized Federal, State and local law enforcement officers may carry firearms in the performance of their official duties.

(e) The carrying or possessing of a weapon, trap or net in violation of applicable Federal and State laws is prohibited.

(f) The regulations contained in this section apply, regardless of land ownership, on all lands and waters within the boundaries of the area administered by the Presidio Trust that are under the legislative jurisdiction of the United States.

### § 1002.5 Research specimens.

(a) Taking plants, fish, wildlife, rocks or minerals except in accordance with other regulations of this chapter or pursuant to the terms and conditions of a specimen collection permit, is prohibited.

(b) A specimen collection permit may be issued only to an official representative of a reputable scientific or educational institution or a State or Federal agency for the purpose of research, baseline inventories, monitoring, impact analysis, group study, or museum

display when the Executive Director determines that the collection is necessary to the stated scientific or resource management goals of the institution or agency and that all applicable Federal and State permits have been acquired, and that the intended use of the specimens and their final disposal is in accordance with applicable law and Federal administrative policies. A permit shall not be issued if removal of the specimen would result in damage to other natural or cultural resources, affect adversely environmental or scenic values, or if the specimen is readily available outside of the area administered by the Presidio Trust.

(c) A permit to take an endangered or threatened species listed pursuant to the Endangered Species Act, or similarly identified by the States, shall not be issued unless the species cannot be obtained outside of the area administered by the Presidio Trust and the primary purpose of the collection is to enhance the protection or management of the species.

(d) A permit authorizing the killing of plants, fish or wildlife may be issued only when the Executive Director approves a written research proposal and determines that the collection will not be inconsistent with the purposes of the Presidio Trust Act and has the potential for conserving and perpetuating the species subject to collection.

(e) Specimen collection permits shall contain the following conditions:

(1) Specimens placed in displays or collections will bear official National Park Service museum labels and their catalog numbers will be registered in the National Park Service National Catalog.

(2) Specimens and data derived from consumed specimens will be made available to the public and reports and publications resulting from a research specimen collection permit shall be filed with the Executive Director.

(f) Violation of the terms and conditions of a permit issued in accordance with this section is prohibited and may result in the suspension or revocation of the permit.

## Presidio Trust

## § 1002.13

### § 1002.10 Camping and food storage.

(a) The Board may require permits, designate sites or areas, and establish conditions for camping.

(b) The following are prohibited:

(1) Digging or leveling the ground at a campsite.

(2) Leaving camping equipment, site alterations, or refuse after departing from the campsite.

(3) Camping within 25 feet of a water hydrant or main road, or within 100 feet of a flowing stream, river or body of water, except as designated.

(4) Creating or sustaining unreasonable noise between the hours of 10:00 p.m. and 6:00 a.m., considering the nature and purpose of the actor's conduct, impact on visitors or tenants, location, and other factors which would govern the conduct of a reasonably prudent person under the circumstances.

(5) The installation of permanent camping facilities.

(6) Displaying wildlife carcasses or other remains or parts thereof.

(7) Connecting to a utility system, except as designated.

(8) Failing to obtain a permit, where required.

(9) Violating conditions which may be established by the Board.

(10) Camping outside of designated sites or areas.

(c) Violation of the terms and conditions of a permit issued in accordance with this section is prohibited and may result in the suspension or revocation of the permit.

(d) *Food storage.* The Board may designate all or a portion of the area administered by the Presidio Trust where food, lawfully taken fish or wildlife, garbage, and equipment used to cook or store food must be kept sealed in a vehicle, or in a camping unit that is constructed of solid, non-pliable material, or suspended at least 10 feet above the ground and 4 feet horizontally from a post, tree trunk, or other object, or shall be stored as otherwise designated. Violation of this restriction is prohibited. This restriction does not apply to food that is being transported, consumed, or prepared for consumption.

### § 1002.11 Picnicking.

Picnicking is allowed, except in designated areas closed in accordance with §1001.5 of this chapter. The Board may establish conditions for picnicking in areas where picnicking is allowed. Picnicking in violation of established conditions is prohibited.

### § 1002.12 Audio disturbances.

(a) The following are prohibited:

(1) Operating motorized equipment or machinery such as an electric generating plant, motor vehicle, motorized toy, or an audio device, such as a radio, television set, tape deck or musical instrument, in a manner that exceeds a noise level of 60 decibels measured on the A-weighted scale at 50 feet; or that, if below that level, nevertheless makes noise which is unreasonable, considering the nature and purpose of the actor's conduct, location, time of day or night, purposes of the Presidio Trust Act, impact on visitors or tenants, and other factors that would govern the conduct of a reasonably prudent person under the circumstances.

(2) In developed areas, operating a power saw, except pursuant to the terms and conditions of a permit.

(3) In nondeveloped areas, operating any type of portable motor or engine, or device powered by a portable motor or engine, except pursuant to the terms and conditions of a permit.

(4) Operating a public address system, except in connection with a public gathering or special event for which a permit has been issued pursuant to §1002.50 or §1002.51.

(b) Violation of the terms and conditions of a permit issued in accordance with this section is prohibited and may result in the suspension or revocation of the permit.

### § 1002.13 Fires.

(a) The following are prohibited:

(1) Lighting or maintaining a fire, except in designated areas or receptacles and under conditions that may be established by the Board.

(2) Using stoves or lanterns in violation of established restrictions.

(3) Lighting, tending, or using a fire, stove or lantern in a manner that threatens, causes damage to, or results

**§ 1002.14**

**36 CFR Ch. X (7-1-03 Edition)**

in the burning of property, real property or resources of the area administered by the Presidio Trust, or creates a public safety hazard.

(4) Leaving a fire unattended.

(5) Throwing or discarding lighted or smoldering material in a manner that threatens, causes damage to, or results in the burning of property or resources of the area administered by the Presidio Trust, or creates a public safety hazard.

(b) Fires shall be extinguished upon termination of use and in accordance with such conditions as may be established by the Board. Violation of these conditions is prohibited.

(c) During periods of high fire danger, the Executive Director may close all or a portion of the area administered by the Presidio Trust to the lighting or maintaining of a fire.

(d) The regulations contained in this section apply, regardless of land ownership, on all lands and waters within the boundaries of the area administered by the Presidio Trust that are under the legislative jurisdiction of the United States.

**§ 1002.14 Sanitation and refuse.**

(a) The following are prohibited:

(1) Disposing of refuse in other than refuse receptacles.

(2) Using government refuse receptacles or other refuse facilities for dumping household, commercial, or industrial refuse, brought as such from private or municipal property, except in accordance with conditions established by the Executive Director.

(3) Depositing refuse in the plumbing fixtures or vaults of a toilet facility.

(4) Draining refuse from a trailer or other vehicle, except in facilities provided for such purpose.

(5) Bathing, or washing food, clothing, dishes, or other property at public water outlets, fixtures or pools, except at those designated for such purpose.

(6) Polluting or contaminating waters or water courses within the area administered by the Presidio Trust.

(7) Disposing of fish remains on land, or in waters within 200 feet of boat docks or designated swimming beaches, or within developed areas, except as otherwise designated.

(8) In developed areas, the disposal of human body waste, except at designated locations or in fixtures provided for that purpose.

(9) In nondeveloped areas, the disposal of human body waste within 100 feet of a water source, high water mark of a body of water, or a campsite, or within sight of a trail, except as otherwise designated.

(b) The Board may establish conditions concerning the disposal, containerization, or carryout of human body waste. Violation of these conditions is prohibited.

**§ 1002.15 Pets.**

(a) The following are prohibited:

(1) Possessing a pet in a public building, public transportation vehicle, or location designated as a swimming beach, or any structure or area closed to the possession of pets by the Board. This paragraph shall not apply to guide dogs accompanying visually impaired persons or hearing ear dogs accompanying hearing-impaired persons.

(2) Failing to crate, cage, restrain on a leash which shall not exceed six feet in length, or otherwise physically confine a pet at all times.

(3) Leaving a pet unattended and tied to an object, except in designated areas or under conditions which may be established by the Board.

(4) Allowing a pet to make noise that is unreasonable considering location, time of day or night, impact on visitors or tenants, and other relevant factors, or that frightens wildlife by barking, howling, or making other noise.

(5) Failing to comply with pet excrement disposal conditions which may be established by the Board.

(b) Pets or feral animals that are running-at-large and observed by an authorized person in the act of killing, injuring or molesting humans, livestock, or wildlife may be destroyed if necessary for public safety or protection of wildlife, livestock, or other resources of the area administered by the Presidio Trust.

(c) Pets running-at-large may be impounded, and the owner may be charged reasonable fees for kennel or boarding costs, feed, veterinarian fees, transportation costs, and disposal. An



## Presidio Trust

## § 1002.17

impounded pet may be put up for adoption or otherwise disposed of after being held for 72 hours from the time the owner was notified of capture or 72 hours from the time of capture if the owner is unknown.

(d) Pets may be kept by residents of the area administered by the Presidio Trust consistent with the provisions of this section and in accordance with conditions which may be established by the Board. Violation of these conditions is prohibited.

(e) This section does not apply to dogs used by authorized Federal, State and local law enforcement officers in the performance of their official duties.

### § 1002.16 Horses and pack animals.

The following are prohibited:

(a) The use of animals other than those designated as "pack animals" for purposes of transporting equipment.

(b) The use of horses or pack animals outside of trails, routes or areas designated for their use.

(c) The use of horses or pack animals on a Presidio Trust road, except where such travel is necessary to cross to or from designated trails, or areas, or privately owned property, and no alternative trails or routes have been designated; or when the road has been closed to motor vehicles.

(d) Free-trailing or loose-herding of horses or pack animals on trails, except as designated.

(e) Allowing horses or pack animals to proceed in excess of a slow walk when passing in the immediate vicinity of persons on foot or bicycle.

(f) Obstructing a trail, or making an unreasonable noise or gesture, considering the nature and purpose of the actor's conduct, and other factors that would govern the conduct of a reasonably prudent person, while horses or pack animals are passing.

(g) Violation of conditions which may be established by the Board concerning the use of horses or pack animals.

### § 1002.17 Aircraft and air delivery.

(a) Delivering or retrieving a person or object by parachute, helicopter, or other airborne means, except in emergencies involving public safety or serious property loss, or pursuant to the

terms and conditions of a permit, is prohibited.

(b) The provisions of this section, other than paragraph (c) of this section, shall not be applicable to official business of the Federal government, or emergency rescues in accordance with the directions of the Executive Director, or to landings due to circumstances beyond the control of the operator.

(c)(1) Except as provided in paragraph (c)(3) of this section, the owners of a downed aircraft shall remove the aircraft and all component parts thereof in accordance with procedures established by the Executive Director. In establishing removal procedures, the Executive Director is authorized to establish a reasonable date by which aircraft removal operations must be complete; determine times and means of access to and from the downed aircraft; and specify the manner or method of removal.

(2) Failure to comply with procedures and conditions established under paragraph (c)(1) of this section is prohibited.

(3) The Executive Director may waive the requirements of paragraph (c)(1) of this section or prohibit the removal of downed aircraft, upon a determination that the removal of downed aircraft would constitute an unacceptable risk to human life; the removal of a downed aircraft would result in extensive resource damage; or the removal of a downed aircraft is impracticable or impossible.

(d) The use of aircraft shall be in accordance with regulations of the Federal Aviation Administration as found in 14 CFR chapter I.

(e) The operation or use of hovercraft is prohibited.

(f) Violation of the terms and conditions of a permit issued in accordance with this section is prohibited and may result in the suspension or revocation of the permit.

(g) The use of devices designed to carry persons through the air in powerless flight is allowed at times and locations designated by the Board, pursuant to the terms and conditions of a permit.

**§ 1002.18**

**§ 1002.18 Snowmobiles.**

The use of snowmobiles is prohibited.

**§ 1002.19 Winter activities.**

(a) Skiing, snowshoeing, ice skating, sledding, innertubing, tobogganing and similar winter sports are prohibited on Presidio Trust roads and in parking areas open to motor vehicle traffic, except as otherwise designated.

(b) The towing of persons on skis, sleds, or other sliding devices by motor vehicle or snowmobile is prohibited, except in designated areas or routes.

(c) Failure to abide by area designations or activity restrictions established under this section is prohibited.

**§ 1002.20 Skating, skateboards and similar devices.**

Using roller skates, skateboards, roller skis, coasting vehicles, or similar devices is prohibited, except in designated areas.

**§ 1002.21 Smoking.**

(a) The Board may designate a portion of the area administered by the Presidio Trust, or all or a portion of a building, structure or facility as closed to smoking when necessary to protect resources, reduce the risk of fire, or prevent conflicts among visitor use activities. Smoking in an area or location so designated is prohibited.

(b) Smoking is prohibited within all caves and caverns.

**§ 1002.22 Property.**

(a) The following are prohibited:

(1) Abandoning property.

(2) Leaving property unattended for longer than 24 hours, except in locations where longer time periods have been designated or in accordance with coBoard.

(3) Failing to turn in found property to the Executive Director as soon as practicable.

(b) *Impoundment of property.* (1) Property determined to be left unattended in excess of an allowed period of time may be impounded by the Executive Director.

(2) Unattended property that interferes with visitor safety or orderly management of the area administered by the Presidio Trust, or that presents a threat to resources of the area ad-

**36 CFR Ch. X (7-1-03 Edition)**

ministered by the Presidio Trust may be impounded by the Executive Director at any time.

(3) Found or impounded property shall be inventoried to determine ownership and safeguard personal property.

(4) The owner of record is responsible and liable for charges to the person who has removed, stored, or otherwise disposed of property impounded pursuant to this section; or the Executive Director may assess the owner reasonable fees for the impoundment and storage of property impounded pursuant to this section.

(c) *Disposition of property.* (1) Unattended property impounded pursuant to this section shall be deemed to be abandoned unless claimed by the owner or an authorized representative thereof within 60 days. The 60-day period shall begin when the rightful owner of the property has been notified, if the owner can be identified, or from the time the property was placed in the Executive Director's custody, if the owner cannot be identified.

(2) Unclaimed, found property shall be stored for a minimum period of 60 days and, unless claimed by the owner or an authorized representative thereof, may be claimed by the finder, provided that the finder is not an employee of the Presidio Trust. Found property not claimed by the owner or an authorized representative or the finder shall be deemed abandoned.

(3) Abandoned property shall be disposed of in accordance with law.

(4) Property, including real property, located within the area administered by the Presidio Trust and owned by a deceased person, shall be disposed of in accordance with the laws of the State within whose exterior boundaries the property is located.

(d) The regulations contained in paragraphs (a)(2), (b) and (c) of this section apply, regardless of land ownership, on all lands and waters within the boundaries of the area administered by the Presidio Trust that are under the legislative jurisdiction of the United States.

**§ 1002.23 Recreation fees.**

(a) Recreation fees shall be charged in the area administered by the Presidio Trust to the same extent that

## Presidio Trust

## § 1002.32

recreation fees have been established for the Golden Gate National Recreation Area in accordance with 36 CFR part 71.

(b) Entering designated entrance fee areas or using specialized sites, facilities, equipment or services, or participating in group activities, recreation events, or other specialized recreation uses for which recreation fees have been established without paying the required fees and possessing the applicable permits is prohibited. Violation of the terms and conditions of a permit issued in accordance with this section is prohibited and may result in the suspension or revocation of the permit.

(c) The Executive Director may, when in the public interest, prescribe periods during which the collection of recreation fees shall be suspended.

### § 1002.30 Misappropriation of property and services.

(a) The following are prohibited:

(1) Obtaining or exercising unlawful possession over the property of another with the purpose to deprive the owner of the property.

(2) Obtaining property or services offered for sale or compensation without making payment or offering to pay.

(3) Obtaining property or services offered for sale or compensation by means of deception or a statement of past, present or future fact that is instrumental in causing the wrongful transfer of property or services, or using stolen, forged, expired, revoked or fraudulently obtained credit cards or paying with negotiable paper on which payment is refused.

(4) Concealing unpurchased merchandise on or about the person without the knowledge or consent of the seller or paying less than purchase price by deception.

(5) Acquiring or possessing the property of another, with knowledge or reason to believe that the property is stolen.

(b) The regulations contained in this section apply, regardless of land ownership, on all lands and waters within the boundaries of the area administered by the Presidio Trust that are under the legislative jurisdiction of the United States.

### § 1002.31 Trespassing, tampering and vandalism.

(a) The following are prohibited:

(1) *Trespassing.* Trespassing, entering or remaining in or upon property or real property not open to the public, except with the express invitation or consent of the person having lawful control of the property or real property.

(2) *Tampering.* Tampering or attempting to tamper with property or real property, or moving, manipulating or setting in motion any of the parts thereof, except when such property is under one's lawful control or possession.

(3) *Vandalism.* Destroying, injuring, defacing, or damaging property or real property.

(b) The regulations contained in this section apply, regardless of land ownership, on all lands and waters within the boundaries of the area administered by the Presidio Trust that are under the legislative jurisdiction of the United States.

### § 1002.32 Interfering with agency functions.

(a) The following are prohibited:

(1) *Interference.* Threatening, resisting, intimidating, or intentionally interfering with a government employee or agent engaged in an official duty, or on account of the performance of an official duty.

(2) *Lawful order.* Violating the lawful order of a government employee or agent authorized to maintain order and control public access and movement during fire fighting operations, search and rescue operations, wildlife management operations involving animals that pose a threat to public safety, law enforcement actions, and emergency operations that involve a threat to public safety or resources of the area administered by the Presidio Trust, or other activities where the control of public movement and activities is necessary to maintain order and public safety.

(3) *False information.* Knowingly giving a false or fictitious report or other false information to an authorized person investigating an accident or violation of law or regulation, or on an application for a permit.

**§ 1002.33**

(4) *False Report.* Knowingly giving a false report for the purpose of misleading a government employee or agent in the conduct of official duties, or making a false report that causes a response by the United States to a fictitious event.

(b) The regulations contained in this section apply, regardless of land ownership, on all lands and waters within the boundaries of the area administered by the Presidio Trust that are under the legislative jurisdiction of the United States.

**§ 1002.33 Report of injury or damage.**

(a) A person involved in an incident resulting in personal injury or property damage exceeding \$300, other than an accident reportable under §1004.4 of this chapter, shall report the incident to the Executive Director as soon as possible. This notification does not satisfy reporting requirements imposed by applicable State law.

(b) Failure to report an incident in accordance with paragraph (a) of this section is prohibited.

**§ 1002.34 Disorderly conduct.**

(a) A person commits disorderly conduct when, with intent to cause public alarm, nuisance, jeopardy or violence, or knowingly or recklessly creating a risk thereof, such person commits any of the following prohibited acts:

(1) Engages in fighting or threatening, or in violent behavior.

(2) Uses language, an utterance, or gesture, or engages in a display or act that is obscene, physically threatening or menacing, or done in a manner that is likely to inflict injury or incite an immediate breach of the peace.

(3) Makes noise that is unreasonable, considering the nature and purpose of the actor's conduct, location, time of day or night, and other factors that would govern the conduct of a reasonably prudent person under the circumstances.

(4) Creates or maintains a hazardous or physically offensive condition.

(b) The regulations contained in this section apply, regardless of land ownership, on all lands and waters within the boundaries of the area administered by the Presidio Trust that are under the

**36 CFR Ch. X (7-1-03 Edition)**

legislative jurisdiction of the United States.

**§ 1002.35 Alcoholic beverages and controlled substances.**

(a) *Alcoholic beverages.* (1) The use and possession of alcoholic beverages within the area administered by the Presidio Trust is allowed in accordance with the provisions of this section.

(2) The following are prohibited:

(i) The sale or gift of an alcoholic beverage to a person under 21 years of age, except where allowed by State law. In a State where a lower minimum age is established, that age limit will apply for purposes of this paragraph.

(ii) The possession of an alcoholic beverage by a person under 21 years of age, except where allowed by State law. In a State where a lower minimum age is established, that age will apply for purposes of this paragraph.

(3)(i) The Board may close all or a portion of a public use area or public facility within the area administered by the Presidio Trust to the consumption of alcoholic beverages and/or to the possession of a bottle, can or other receptacle containing an alcoholic beverage that is open, or that has been opened, or whose seal is broken or the contents of which have been partially removed. Provided however, that such a closure may only be implemented following a determination made by the Board that:

(A) The consumption of an alcoholic beverage or the possession of an open container of an alcoholic beverage would be inappropriate considering other uses of the location and the purpose for which it is maintained or established; or

(B) Incidents of aberrant behavior related to the consumption of alcoholic beverages are of such magnitude that the diligent application of the authorities in this section and §§1001.5 and 1002.34 of this chapter, over a reasonable time period, does not alleviate the problem.

(ii) A closure imposed by the Board does not apply to an open container of an alcoholic beverage that is stored in compliance with the provisions of § 1004.14 of this chapter.

(iii) Violating a closure imposed pursuant to this section is prohibited.

## Presidio Trust

## § 1002.50

(b) *Controlled substances.* The following are prohibited:

(1) The delivery of a controlled substance, except when distribution is made by a practitioner in accordance with applicable law. For the purposes of this paragraph, delivery means the actual, attempted or constructive transfer of a controlled substance whether or not there exists an agency relationship.

(2) The possession of a controlled substance, unless such substance was obtained by the possessor directly, or pursuant to a valid prescription or order, from a practitioner acting in the course of professional practice or otherwise allowed by Federal or State law.

(c) Presence within the area administered by the Presidio Trust when under the influence of alcohol or a controlled substance to a degree that may endanger oneself or another person, or damage property or resources of the area administered by the Presidio Trust, is prohibited.

### § 1002.36 Gambling.

(a) Gambling in any form, or the operation of gambling devices, is prohibited.

(b) This regulation applies, regardless of land ownership, on all lands and waters within the boundaries of the area administered by the Presidio Trust that are under the legislative jurisdiction of the United States.

### § 1002.37 Noncommercial soliciting.

Soliciting or demanding gifts, money, goods or services is prohibited, except pursuant to the terms and conditions of a permit that has been issued under § 1002.50, § 1002.51 or § 1002.52.

### § 1002.38 Explosives.

(a) Using, possessing, storing, or transporting explosives, blasting agents or explosive materials is prohibited, except pursuant to the terms and conditions of a permit. When permitted, the use, possession, storage and transportation shall be in accordance with applicable Federal and State laws.

(b) Using or possessing fireworks and firecrackers is prohibited, except pursuant to the terms and conditions of a permit or in designated areas under such conditions as the Board may es-

tablish, and in accordance with applicable State law.

(c) Violation of the conditions established by the Board or of the terms and conditions of a permit issued in accordance with this section is prohibited and may result in the suspension or revocation of the permit.

### § 1002.50 Special events.

(a) Sports events, pageants, regattas, public spectator attractions, entertainments, ceremonies, and similar events are allowed: Provided, however, There is a meaningful association between the area administered by the Presidio Trust and the events, and the observance contributes to visitor understanding of the significance of the area administered by the Presidio Trust, and a permit therefore has been issued by the Executive Director. A permit shall be denied if such activities would:

(1) Cause injury or damage to resources of the area administered by the Presidio Trust; or

(2) Be contrary to the purposes of the Presidio Trust Act; or

(3) Unreasonably interfere with interpretive, visitor service, or other program activities, or with the administrative activities of the Presidio Trust or the National Park Service; or

(4) Substantially impair the operation of public use facilities or services of Presidio Trust concessioners or contractors; or

(5) Present a clear and present danger to the public health and safety; or

(6) Result in significant conflict with other existing uses.

(b) An application for such a permit shall set forth the name of the applicant, the date, time, duration, nature and place of the proposed event, an estimate of the number of persons expected to attend, a statement of equipment and facilities to be used, and any other information required by the Executive Director. The application shall be submitted so as to reach the Executive Director at least 72 hours in advance of the proposed event.

(c) As a condition of permit issuance, the Executive Director may require:

(1) The filing of a bond payable to the Presidio Trust, in an amount adequate to cover costs such as restoration, rehabilitation, and cleanup of the area

§ 1002.51

36 CFR Ch. X (7-1-03 Edition)

used, and other costs resulting from the special event. In lieu of a bond, a permittee may elect to deposit cash equal to the amount of the required bond.

(2) In addition to the requirements of paragraph (c)(1) of this section, the acquisition of liability insurance in which the United States is named as co-insured in an amount sufficient to protect the United States.

(d) The permit may contain such conditions as are reasonably consistent with protection and use of the area administered by the Presidio Trust for the purposes of the Presidio Trust Act. It may also contain reasonable limitations on the equipment used and the time and area within which the event is allowed.

(e) Violation of the terms and conditions of a permit issued in accordance with this section is prohibited and may result in the suspension or revocation of the permit.

**§ 1002.51 Public assemblies, meetings.**

(a) Public assemblies, meetings, gatherings, demonstrations, parades and other public expressions of views are allowed within the area administered by the Presidio Trust, provided a permit therefore has been issued by the Executive Director.

(b) An application for such a permit shall set forth the name of the applicant; the date, time, duration, nature and place of the proposed event; an estimate of the number of persons expected to attend; a statement of equipment and facilities to be used and any other information required by the permit application form.

(c) The Executive Director shall, without unreasonable delay, issue a permit on proper application unless:

(1) A prior application for a permit for the same time and place has been made that has been or will be granted and the activities authorized by that permit do not reasonably allow multiple occupancy of that particular area; or

(2) It reasonably appears that the event will present a clear and present danger to the public health or safety; or

(3) The event is of such nature or duration that it cannot reasonably be ac-

commodated in the particular location applied for, considering such things as damage to resources or facilities of the area administered by the Presidio Trust, impairment of a protected area's atmosphere of peace and tranquillity, interference with program activities, or impairment of public use facilities.

(d) If a permit is denied, the applicant shall be so informed in writing, with the reason(s) for the denial set forth.

(e) The Board shall designate on a map, that shall be available in the office of the Presidio Trust, the locations available for public assemblies. Locations may be designated as not available only if such activities would:

(1) Cause injury or damage to resources of the area administered by the Presidio Trust; or

(2) Unreasonably impair the atmosphere of peace and tranquillity maintained in wilderness, natural, historic or commemorative zones; or

(3) Unreasonably interfere with interpretive, visitor service, or other program activities, or with the administrative activities of the Presidio Trust or the National Park Service; or

(4) Substantially impair the operation of public use facilities or services of Presidio Trust concessioners or contractors; or

(5) Present a clear and present danger to the public health and safety.

(f) The permit may contain such conditions as are reasonably consistent with protection and use of the area administered by the Presidio Trust for the purposes of the Presidio Trust Act. It may also contain reasonable limitations on the equipment used and the time and area within which the event is allowed.

(g) No permit shall be issued for a period in excess of 7 days, provided that permits may be extended for like periods, upon a new application, unless another applicant has requested use of the same location and multiple occupancy of that location is not reasonably possible.

(h) It is prohibited for persons engaged in activities covered under this section to obstruct or impede pedestrians or vehicles, or harass visitors with physical contact.

## Presidio Trust

## § 1002.52

(i) A permit may be revoked under any of those conditions, as listed in paragraph (c) of this section, that constitute grounds for denial of a permit, or for violation of the terms and conditions of the permit. Such a revocation shall be made in writing, with the reason(s) for revocation clearly set forth, except under emergency circumstances, when an immediate verbal revocation or suspension may be made to be followed by written confirmation within 72 hours.

(j) Violation of the terms and conditions of a permit issued in accordance with this section may result in the suspension or revocation of the permit.

### § 1002.52 Sale or distribution of printed matter.

(a) The sale or distribution of printed matter is allowed within the area administered by the Presidio Trust, provided that a permit to do so has been issued by the Executive Director, and provided further that the printed matter is not solely commercial advertising.

(b) An application for such a permit shall set forth the name of the applicant; the name of the organization (if any); the date, time, duration, and location of the proposed sale or distribution; the number of participants; and any other information required by the permit application form.

(c) The Executive Director shall, without unreasonable delay, issue a permit on proper application unless:

(1) A prior application for a permit for the same time and location has been made that has been or will be granted and the activities authorized by that permit do not reasonably allow multiple occupancy of the particular area; or

(2) It reasonably appears that the sale or distribution will present a clear and present danger to the public health and safety; or

(3) The number of persons engaged in the sale or distribution exceeds the number that can reasonably be accommodated in the particular location applied for, considering such things as damage to resources or facilities of the area administered by the Presidio Trust, impairment of a protected area's atmosphere of peace and tranquillity,

interference with program activities, or impairment of public use facilities; or

(4) The location applied for has not been designated as available for the sale or distribution of printed matter; or

(5) The activity would constitute a violation of an applicable law or regulation.

(d) If a permit is denied, the applicant shall be so informed in writing, with the reason(s) for the denial set forth.

(e) The Board shall designate on a map, which shall be available for inspection in the office of the Presidio Trust, the locations within the area administered by the Presidio Trust that are available for the sale or distribution of printed matter. Locations may be designated as not available only if the sale or distribution of printed matter would:

(1) Cause injury or damage to resources of the area administered by the Presidio Trust; or

(2) Unreasonably impair the atmosphere of peace and tranquillity maintained in wilderness, natural, historic, or commemorative zones; or

(3) Unreasonably interfere with interpretive, visitor service, or other program activities, or with the administrative activities of the Presidio Trust or the National Park Service; or

(4) Substantially impair the operation of public use facilities or services of Presidio Trust concessioners or contractors; or

(5) Present a clear and present damage to the public health and safety.

(f) The permit may contain such conditions as are reasonably consistent with protection and use of the area administered by the Presidio Trust for the purposes of the Presidio Trust Act.

(g) No permit shall be issued for a period in excess of 14 consecutive days, provided that permits may be extended for like periods, upon a new application, unless another applicant has requested use of the same location and multiple occupancy of that location is not reasonably possible.

(h) It is prohibited for persons engaged in the sale or distribution of printed matter under this section to

**§ 1002.60**

**36 CFR Ch. X (7-1-03 Edition)**

obstruct or impede pedestrians or vehicles, harass visitors with physical contact or persistent demands, misrepresent the purposes or affiliations of those engaged in the sale or distribution, or misrepresent whether the printed matter is available without cost or donation.

(i) A permit may be revoked under any of those conditions, as listed in paragraph (c) of this section, that constitute grounds for denial of a permit, or for violation of the terms and conditions of the permit. Such a revocation shall be made in writing, with the reason(s) for revocation clearly set forth, except under emergency circumstances, when an immediate verbal revocation or suspension may be made, to be followed by written confirmation within 72 hours.

(j) Violation of the terms and conditions of a permit issued in accordance with this section may result in the suspension or revocation of the permit.

**§ 1002.60 Livestock use and agriculture.**

(a) The running-at-large, herding, driving across, allowing on, pasturing or grazing of livestock of any kind within the area administered by the Presidio Trust or the use of such area for agricultural purposes is prohibited, except:

(1) As specifically authorized by Federal statutory law; or

(2) As required under a reservation of use rights arising from acquisition of a tract of land; or

(3) As designated, when conducted as a necessary and integral part of a recreational activity or required in order to maintain a historic scene.

(b) Activities authorized pursuant to any of the exceptions provided for in paragraph (a) of this section shall be allowed only pursuant to the terms and conditions of a license, permit or lease. Violation of the terms and conditions of a license, permit or lease issued in accordance with this paragraph is prohibited and may result in the suspension or revocation of the license, permit, or lease.

(c) *Impounding of livestock.* (1) Livestock trespassing within the area administered by the Presidio Trust may be impounded by the Executive Direc-

tor and, if not claimed by the owner within the periods specified in this paragraph, shall be disposed of in accordance with applicable Federal and State law.

(2) In the absence of applicable Federal or State law, the livestock shall be disposed of in the following manner:

(i) If the owner is known, prompt written notice of impoundment will be served, and in the event of the owner's failure to remove the impounded livestock within five (5) days from delivery of such notice, it will be disposed of in accordance with this paragraph.

(ii) If the owner is unknown, disposal of the livestock shall not be made until at least fifteen (15) days have elapsed from the date that a notice of impoundment is originally published in a newspaper of general circulation in the county in which the trespass occurs or, if no such newspaper exists, notification is provided by other appropriate means.

(iii) The owner may redeem the livestock by submitting proof of ownership and paying all expenses of the United States for capturing, advertising, pasturing, feeding, impounding, and the amount of damage to public property injured or destroyed as a result of the trespass.

(iv) In determining the claim of the government in a livestock trespass, the value of forage consumed shall be computed at the commercial rates prevailing in the locality for the class of livestock found in trespass. The claim shall include the pro rata salary of employees for the time spent and the expenses incurred as a result of the investigation, reporting, and settlement or prosecution of the claim.

(v) If livestock impounded under this paragraph is offered at public sale and no bid is received, or if the highest bid received is less than the amount of the claim of the United States or of the officer's appraised value of the livestock, whichever is the lesser amount, such livestock, may be sold at private sale for the highest amount obtainable, condemned and destroyed, or converted to the use of the United States.

**§ 1002.61 Residing on Federal lands.**

(a) Residing within the area administered by the Presidio Trust, other than



## Presidio Trust

on privately owned lands, except pursuant to the terms and conditions of a permit, lease or contract, is prohibited.

(b) Violation of the terms and conditions of a permit issued in accordance with this section is prohibited and may result in the suspension or revocation of the permit.

### § 1002.62 Memorialization.

(a) The installation of a monument, memorial, tablet, structure, or other commemorative installation within the area administered by the Presidio Trust without the authorization of the Board is prohibited.

(b) The scattering of human ashes from cremation is prohibited, except pursuant to the terms and conditions of a permit, or in designated areas according to conditions which may be established by the Board.

(c) Failure to abide by area designations and established conditions is prohibited.

(d) Violation of the terms and conditions of a permit issued in accordance with this section is prohibited and may result in the suspension or revocation of the permit.

### § 1002.63 Boating and water use activities.

Swimming, boating and the use of any water vessel are prohibited within the area administered by the Presidio Trust.

## PART 1004—VEHICLES AND TRAFFIC SAFETY

Sec.

- 1004.1 Applicability and scope.
- 1004.2 State law applicable.
- 1004.3 Authorized emergency vehicles.
- 1004.4 Report of motor vehicle accident.
- 1004.10 Travel on Presidio Trust roads and designated routes.
- 1004.11 Load, weight and size limits.
- 1004.12 Traffic control devices.
- 1004.13 Obstructing traffic.
- 1004.14 Open container of alcoholic beverage.
- 1004.15 Safety belts.
- 1004.20 Right of way.
- 1004.21 Speed limits.
- 1004.22 Unsafe operation.
- 1004.23 Operating under the influence of alcohol or drugs.
- 1004.30 Bicycles.
- 1004.31 Hitchhiking.

## § 1004.4

AUTHORITY: Pub. L. 104-333, 110 Stat. 4097 (16 U.S.C. 460bb note).

SOURCE: 63 FR 35708, June 30, 1998, unless otherwise noted.

### § 1004.1 Applicability and scope.

The applicability of the regulations in this part is described in §1001.2 of this chapter. The regulations in this part also apply, regardless of land ownership, on all roadways and parking areas within the boundaries of the area administered by the Presidio Trust that are open to public traffic and that are under the legislative jurisdiction of the United States.

### § 1004.2 State law applicable.

(a) Unless specifically addressed by regulations in this chapter, traffic and the use of vehicles within the boundaries of the area administered by the Presidio Trust are governed by State law. State law that is now or may later be in effect is adopted and made a part of the regulations in this part.

(b) Violating a provision of State law is prohibited.

### § 1004.3 Authorized emergency vehicles.

(a) The operator of an authorized emergency vehicle, when responding to an emergency or when pursuing or apprehending an actual or suspected violator of the law, may:

- (1) Disregard traffic control devices;
- (2) Exceed the speed limit; and
- (3) Obstruct traffic.

(b) The provisions of paragraph (a) of this section do not relieve the operator from the duty to operate with due regard for the safety of persons and property.

### § 1004.4 Report of motor vehicle accident.

(a) The operator of a motor vehicle involved in an accident resulting in property damage, personal injury or death shall report the accident to the Executive Director as soon as practicable, but within 24 hours of the accident. If the operator is physically incapable of reporting the accident, an occupant of the vehicle shall report the accident to the Executive Director.

#### § 1004.10

(b) A person shall not tow or move a vehicle that has been involved in an accident without first notifying the Executive Director unless the position of the vehicle constitutes a hazard or prior notification is not practicable, in which case notification shall be made before the vehicle is removed from the area administered by the Presidio Trust.

(c) Failure to comply with a reporting requirement specified in paragraph (a) or (b) of this section is prohibited.

(d) The notification requirements imposed by this section do not relieve the operator and occupants of a motor vehicle involved in an accident of the responsibility to satisfy reporting requirements imposed by State law.

#### § 1004.10 Travel on Presidio Trust roads and designated routes.

(a) Operating a motor vehicle is prohibited except on Presidio Trust roads and in parking areas.

(b) The following are prohibited:

(1) Operating a motor vehicle not equipped with pneumatic tires, except that a track-laying motor vehicle or a motor vehicle equipped with a similar traction device may be operated on a route designated for these vehicles by the Board.

(2) Operating a motor vehicle in a manner that causes unreasonable damage to the surface of a Presidio Trust road or route.

#### § 1004.11 Load, weight and size limits.

(a) Vehicle load, weight and size limits established by State law apply to a vehicle operated on a Presidio Trust road. However, the Board may designate more restrictive limits when appropriate for traffic safety or protection of the road surface. The Board may require a permit and establish conditions for the operation of a vehicle exceeding designated limits.

(b) The following are prohibited:

(1) Operating a vehicle that exceeds a load, weight or size limit designated by the Board.

(2) Failing to obtain a permit when required.

(3) Violating a term or condition of a permit.

(4) Operating a motor vehicle with an auxiliary detachable side mirror that

#### 36 CFR Ch. X (7-1-03 Edition)

extends more than 10 inches beyond the side fender line except when the motor vehicle is towing a second vehicle.

(c) Violating a term or condition of a permit may also result in the suspension or revocation of the permit by the Executive Director.

#### § 1004.12 Traffic control devices.

Failure to comply with the directions of a traffic control device is prohibited unless otherwise directed by the Executive Director.

#### § 1004.13 Obstructing traffic.

The following are prohibited:

(a) Stopping or parking a vehicle upon a Presidio Trust road, except as authorized by the Executive Director, or in the event of an accident or other condition beyond the control of the operator.

(b) Operating a vehicle so slowly as to interfere with the normal flow of traffic.

#### § 1004.14 Open container of alcoholic beverage.

(a) Each person within a motor vehicle is responsible for complying with the provisions of this section that pertain to carrying an open container. The operator of a motor vehicle is the person responsible for complying with the provisions of this section that pertain to the storage of an open container.

(b) Carrying or storing a bottle, can or other receptacle containing an alcoholic beverage that is open, or has been opened, or whose seal is broken or the contents of which have been partially removed, within a motor vehicle in the area administered by the Presidio Trust is prohibited.

(c) This section does not apply to:

(1) An open container stored in the trunk of a motor vehicle or, if a motor vehicle is not equipped with a trunk, to an open container stored in some other portion of the motor vehicle designed for the storage of luggage and not normally occupied by or readily accessible to the operator or passengers; or

(2) An open container stored in the living quarters of a motor home or camper; or

(3) Unless otherwise prohibited, an open container carried or stored in a motor vehicle parked at an authorized

## Presidio Trust

## § 1004.23

campsite where the motor vehicle's occupant(s) are camping.

(d) For the purpose of paragraph (c)(1) of this section, a utility compartment or glove compartment is deemed to be readily accessible to the operator and passengers of a motor vehicle.

### § 1004.15 Safety belts.

(a) Each operator and passenger occupying any seating position of a motor vehicle in the area administered by the Presidio Trust will have the safety belt or child restraint system properly fastened at all times when the vehicle is in motion. The safety belt and child restraint system will conform to applicable United States Department of Transportation standards.

(b) This section does not apply to an occupant in a seat that was not originally equipped by the manufacturer with a safety belt nor does it apply to a person who can demonstrate that a medical condition prevents restraint by a safety belt or other occupant restraining device.

### § 1004.20 Right of way.

An operator of a motor vehicle shall yield the right of way to pedestrians, saddle and pack animals and vehicles drawn by animals. Failure to yield the right of way is prohibited.

### § 1004.21 Speed limits.

(a) Speed limits in the area administered by the Presidio Trust are as follows:

(1) 15 miles per hour: within all school zones, campgrounds, picnic areas, parking areas, utility areas, business or residential areas, other places of public assemblage and at emergency scenes.

(2) 25 miles per hour: upon sections of Presidio Trust road under repair or construction.

(3) 45 miles per hour: upon all other Presidio Trust roads.

(b) The Board may designate a different speed limit upon any Presidio Trust road when a speed limit set forth in paragraph (a) of this section is determined to be unreasonable, unsafe or inconsistent with the purposes of the Presidio Trust Act. Speed limits shall be posted by using standard traffic control devices.

(c) Operating a vehicle at a speed in excess of the speed limit is prohibited.

(d) An authorized person may utilize radiomicrowaves or other electrical devices to determine the speed of a vehicle on a Presidio Trust road. Signs indicating that vehicle speed is determined by the use of radiomicrowaves or other electrical devices are not required.

### § 1004.22 Unsafe operation.

(a) The elements of this section constitute offenses that are less serious than reckless driving. The offense of reckless driving is defined by State law and violations are prosecuted pursuant to the provisions of § 1004.2.

(b) The following are prohibited:

(1) Operating a motor vehicle without due care or at a speed greater than that which is reasonable and prudent considering wildlife, traffic, weather, road and light conditions and road character.

(2) Operating a motor vehicle in a manner which unnecessarily causes its tires to squeal, skid or break free of the road surface.

(3) Failing to maintain that degree of control of a motor vehicle necessary to avoid danger to persons, property or wildlife.

(4) Operating a motor vehicle while allowing a person to ride:

(i) On or within any vehicle, trailer or other mode of conveyance towed behind the motor vehicle unless specifically designed for carrying passengers while being towed; or

(ii) On any exterior portion of the motor vehicle not designed or intended for the use of a passenger. This restriction does not apply to a person seated on the floor of a truck bed equipped with sides, unless prohibited by State law.

### § 1004.23 Operating under the influence of alcohol or drugs.

(a) Operating or being in actual physical control of a motor vehicle is prohibited while:

(1) Under the influence of alcohol, or a drug, or drugs, or any combination thereof, to a degree that renders the operator incapable of safe operation; or

(2) The alcohol concentration in the operator's blood or breath is 0.10 grams

**§ 1004.30**

or more of alcohol per 100 milliliters of blood or 0.10 grams or more of alcohol per 210 liters of breath. Provided however, that if State law that applies to operating a motor vehicle while under the influence of alcohol establishes more restrictive limits of alcohol concentration in the operator's blood or breath, those limits supersede the limits specified in this paragraph.

(b) The provisions of paragraph (a) of this section also apply to an operator who is or has been legally entitled to use alcohol or another drug.

(c) *Tests.* (1) At the request or direction of an authorized person who has probable cause to believe that an operator of a motor vehicle within the area administered by the Presidio Trust has violated a provision of paragraph (a) of this section, the operator shall submit to one or more tests of the blood, breath, saliva or urine for the purpose of determining blood alcohol and drug content.

(2) Refusal by an operator to submit to a test is prohibited and proof of refusal may be admissible in any related judicial proceeding.

(3) Any test or tests for the presence of alcohol and drugs shall be determined by and administered at the direction of an authorized person.

(4) Any test shall be conducted by using accepted scientific methods and equipment of proven accuracy and reliability operated by personnel certified in its use.

(d) *Presumptive levels.* (1) The results of chemical or other quantitative tests are intended to supplement the elements of probable cause used as the basis for the arrest of an operator charged with a violation of paragraph (a)(1) of this section. If the alcohol concentration in the operator's blood or breath at the time of testing is less than alcohol concentrations specified in paragraph (a)(2) of this section, this fact does not give rise to any presumption that the operator is or is not under the influence of alcohol.

(2) The provisions of paragraph (d)(1) of this section are not intended to limit the introduction of any other competent evidence bearing upon the question of whether the operator, at the time of the alleged violation, was under the influence of alcohol, or a

**36 CFR Ch. X (7-1-03 Edition)**

drug, or drugs, or any combination thereof.

**§ 1004.30 Bicycles.**

(a) The use of a bicycle is prohibited except on Presidio Trust roads, in parking areas and on routes designated for bicycle use; provided, however, that the Board may close any Presidio Trust road or parking area to bicycle use pursuant to the criteria and procedures of §§ 1001.5 and 1001.7 of this chapter. Routes may only be designated for bicycle use based on a written determination that such use is consistent with the protection of natural, scenic and aesthetic values, safety considerations and management objectives and will not disturb wildlife or the resources of the area administered by the Presidio Trust.

(b) *Designated bicycle routes.* The use of a bicycle is permitted in non-developed areas, as follows:

(1) Bicycle use is permitted on routes which have been designated by the Board as bicycle routes by the posting of signs, and as designated on maps which are available in the office of the Presidio Trust and other places convenient to the public.

(2) Bicycle speed limits are as follows:

(i) 15 miles per hour: Upon all designated routes within the area administered by the Presidio Trust.

(ii) 5 miles per hour: On blind curves and when passing other trail users.

(3) The following are prohibited:

(i) The possession of a bicycle on routes not designated as open to bicycle use.

(ii) Operating a bicycle on designated bicycle routes between sunset and sunrise without exhibiting on the bicycle or on the operator an activated white light that is visible from a distance of at least 500 feet to the front and with a red light or reflector visible from at least 200 feet to the rear.

(c) A person operating a bicycle is subject to all sections of this part that apply to an operator of a motor vehicle, except §§ 1004.4, 1004.10, 1004.11 and 1004.14.

(d) The following are prohibited:

(1) Possessing a bicycle in a wilderness area established by Federal statute.

## Presidio Trust

## § 1005.5

(2) Operating a bicycle during periods of low visibility, or while traveling through a tunnel, or between sunset and sunrise, without exhibiting on the operator or bicycle a white light or reflector that is visible from a distance of at least 500 feet to the front and with a red light or reflector visible from at least 200 feet to the rear.

(3) Operating a bicycle abreast of another bicycle except where authorized by the Executive Director.

(4) Operating a bicycle while consuming an alcoholic beverage or carrying in hand an open container of an alcoholic beverage.

### § 1004.31 Hitchhiking.

Hitchhiking or soliciting transportation is prohibited except in designated areas and under conditions established by the Board.

## PART 1005—COMMERCIAL AND PRIVATE OPERATIONS

Sec.

1005.1 Advertisements.

1005.2 Alcoholic beverages; sale of intoxicants.

1005.3 Business operations.

1005.4 Commercial passenger-carrying motor vehicles.

1005.5 Commercial photography.

1005.6 Commercial vehicles.

1005.7 Construction of buildings or other facilities.

1005.8 Discrimination in employment practices.

1005.9 Discrimination in furnishing public accommodations and transportation services.

1005.10-1005.12 [Reserved]

1005.13 Nuisances.

1005.14 Prospecting, mining, and mineral leasing.

AUTHORITY: Pub. L. 104-333, 110 Stat. 4097 (16 U.S.C. 460bb note).

SOURCE: 63 FR 35710, June 30, 1998, unless otherwise noted.

### § 1005.1 Advertisements.

Commercial notices or advertisements shall not be displayed, posted, or distributed within the area administered by the Presidio Trust unless prior written permission has been given by the Executive Director. Such permission may be granted only if the notice or advertisement is of goods, services,

or facilities available within the area administered by the Presidio Trust and such notices and advertisements are found by the Executive Director to be desirable and necessary for the convenience and guidance of the public.

### § 1005.2 Alcoholic beverages; sale of intoxicants.

The sale of alcoholic, spirituous, vinous, or fermented liquor, containing more than 1 percent of alcohol by weight, shall conform with all applicable Federal, State, and local laws and regulations. (See also §1002.35 of this chapter.)

### § 1005.3 Business operations.

Engaging in or soliciting any business in the area administered by the Presidio Trust, except in accordance with the provisions of a permit, contract, or other written agreement with the United States, is prohibited.

### § 1005.4 Commercial passenger-carrying motor vehicles.

Passenger-carrying motor vehicles that are so large as to require special escort in order to proceed safely over Presidio Trust roads, or which in the judgment of the Executive Director are beyond the carrying capacity or safety factor of the roads, will not be permitted in the area administered by the Presidio Trust, except that, where they may satisfactorily enter and travel to the Presidio Trust headquarters they may be parked there during the period of stay.

### § 1005.5 Commercial photography.

(a) *Motion pictures, television.* Before any motion picture may be filmed or any television production or sound track may be made, which involves the use of professional casts, settings, or crews, by any person other than bona fide newsreel or news television personnel, written permission must first be obtained from the Executive Director, in accordance with the following:

(1) *Permit required.* No picture may be filmed, and no television production or sound track made on any area administered by the Presidio Trust, by any person other than amateur or bona fide newsreel and news television photographers and soundmen, unless written

§ 1005.6

36 CFR Ch. X (7-1-03 Edition)

permission has been obtained from the Presidio Trust. Applications for permission should be submitted to the Executive Director.

(2) Fees; bonds. (i) No fees will be charged for the making of motion pictures, television productions or sound tracks on areas administered by the Presidio Trust. The regular general admission and other fees currently in effect in any area under the jurisdiction of the Presidio Trust are not affected by this paragraph.

(ii) A bond shall be furnished, or deposit made in cash or by certified check, in an amount to be set by the official in charge of the area to insure full compliance with all of the conditions prescribed in paragraph (a)(4) of this section.

(3) Approval of application. Permission to make a motion picture, television production or sound track on areas administered by the Presidio Trust will be granted by the Executive Director in his discretion and on acceptance by the applicant of the conditions set forth in paragraph (a)(4) of this section.

(4) Form of application. The following form is prescribed for an application for permission to make a motion picture, television production, or sound track on areas administered by the Presidio Trust:

Date \_\_\_\_\_  
To the Executive Director of the Presidio Trust:

Permission is requested to make, in the area administered by the Presidio Trust, a

\_\_\_\_\_ The scope of the filming (or production or recording) and the manner and extent thereof will be as follows:

\_\_\_\_\_ Weather conditions permitting, work will commence on approximately \_\_\_\_\_ and will be completed on approximately \_\_\_\_\_. (An additional sheet should be used if necessary.)

The undersigned accepts and will comply with the following conditions:

Utmost care will be exercised to see that no natural features are injured, and after completion of the work the area will, as required by the official in charge, either be cleaned up and restored to its prior condition or left, after clean-up, in a condition satisfactory to the official in charge.

Credit will be given to the Presidio Trust through the use of an appropriate title or an-

nouncement, unless there is issued by the official in charge of the area a written statement that no such courtesy credit is desired.

Pictures will be taken of wildlife only when such wildlife will be shown in its natural state or under approved management conditions if such wildlife is confined.

Any special instructions received from the official in charge of the area will be complied with.

Any additional information relating to the privilege applied for by this application will be furnished upon request of the official in charge.

\_\_\_\_\_  
(Applicant)  
For \_\_\_\_\_  
(Company)  
Bond Requirement \$ \_\_\_\_\_  
Approved: \_\_\_\_\_  
(Date)  
\_\_\_\_\_  
(Title)

(b) Still photography. The taking of photographs of any vehicle, or other articles of commerce or models for the purpose of commercial advertising without a written permit from the Executive Director is prohibited.

§ 1005.6 Commercial vehicles.

(a) The term "Commercial vehicle" as used in this section shall include, but not be limited to trucks, station wagons, pickups, passenger cars or other vehicles when used in transporting movable property for a fee or profit, either as a direct charge to another person, or otherwise, or used as an incident to providing services to another person, or used in connection with any business.

(b) The use of government roads within the area administered by the Presidio Trust by commercial vehicles, when such use is in no way connected with the operation of the area administered by the Presidio Trust, is prohibited, except that in emergencies the Executive Director may grant permission to use Presidio Trust roads.

(c) The Executive Director shall issue permits for commercial vehicles used on Presidio Trust roads when such use is necessary for access to private lands situated within or adjacent to the area administered by the Presidio Trust, to which access is otherwise not available.

## Presidio Trust

## § 1005.9

### § 1005.7 Construction of buildings or other facilities.

Constructing or attempting to construct a building, or other structure, boat dock, road, trail, path, or other way, telephone line, telegraph line, power line, or any other private or public utility, upon, across, over, through, or under any area administered by the Presidio Trust, except in accordance with the provisions of a valid permit, contract, or other written agreement with the United States, is prohibited.

### § 1005.8 Discrimination in employment practices.

(a) The proprietor, owner, or operator of any hotel, inn, lodge or other facility or accommodation offered to or enjoyed by the general public within the area administered by the Presidio Trust is prohibited from discriminating against any employee or maintaining any employment practice which discriminates because of race, creed, color, ancestry, sex, age, disabling condition, or national origin in connection with any activity provided for or permitted by contract with or permit from the Government or by derivative sub-contract or sublease. As used in this section, the term "employment" includes, but is not limited to, employment, upgrading, demotion, or transfer; recruitment, or recruitment advertising; layoffs or termination; rates of pay or other forms of compensation; and selection for training including apprenticeship.

(b) Each such proprietor, owner or operator shall post either the following notice or notices supplied in accordance with Executive Order 11246 at such locations as will ensure that the notice and its contents will be conspicuous to any person seeking employment:

#### *Notice*

This is a facility operated in an area under the jurisdiction of the Presidio Trust. No discrimination in employment practices on the basis of race, creed, color, ancestry, sex, age, disabling condition, or national origin is permitted in this facility. Violations of this prohibition are punishable by fine, imprisonment, or both. Complaints or violations of this prohibition should be addressed to the Executive Director, The Presidio Trust, P.O. Box 29052, San Francisco, CA 94129-0052.

(c) The regulations contained in this section apply, regardless of land ownership, on all lands and waters within the boundaries of the area administered by the Presidio Trust that are under the legislative jurisdiction of the United States.

### § 1005.9 Discrimination in furnishing public accommodations and transportation services.

(a) The proprietor, owner or operator and the employees of any hotel, inn, lodge, or other facility or accommodation offered to or enjoyed by the general public within the area administered by the Presidio Trust and, while using such area, any commercial passenger-carrying motor vehicle service and its employees, are prohibited from:

(1) Publicizing the facilities, accommodations or any activity conducted therein in any manner that would directly or inferentially reflect upon or question the acceptability of any person or persons because of race, creed, color, ancestry, sex, age, disabling condition, or national origin; or

(2) Discriminating by segregation or otherwise against any person or persons because of race, creed, color, ancestry, sex, age, disabling condition, or national origin in furnishing or refusing to furnish such person or persons any accommodation, facility, service, or privilege offered to or enjoyed by the general public.

(b) Each such proprietor, owner, or operator shall post the following notice at such locations as will insure that the notice and its contents will be conspicuous to any person seeking accommodations, facilities, services, or privileges:

#### *Notice*

This is a facility operated in an area under the jurisdiction of the Presidio Trust. No discrimination by segregation or other means in the furnishing of accommodations, facilities, services, or privileges on the basis of race, creed, color, ancestry, sex, age, disabling condition or national origin is permitted in the use of this facility. Violations of this prohibition are punishable by fine, imprisonment, or both. Complaints of violations of this prohibition should be addressed to the Executive Director, The Presidio Trust, P.O. Box 29052, San Francisco, CA 94129-0052.

(c) The regulations contained in this section apply, regardless of land ownership, on all lands and waters within the boundaries of the area administered by the Presidio Trust that are under the legislative jurisdiction of the United States.

§§ 1005.10–1005.12 [Reserved]

§ 1005.13 Nuisances.

The creation or maintenance of a nuisance upon the federally owned lands of the area administered by the Presidio Trust or upon any private lands within the boundaries of the area administered by the Presidio Trust under the exclusive legislative jurisdiction of the United States is prohibited.

§ 1005.14 Prospecting, mining, and mineral leasing.

Prospecting, mining, and the location of mining claims under the general mining laws and leasing under the mineral leasing laws are prohibited in the area administered by the Presidio Trust except as authorized by law.

**PART 1007—REQUESTS UNDER THE FREEDOM OF INFORMATION ACT**

Sec.

- 1007.1 Purpose and scope.
- 1007.2 Records available.
- 1007.3 Requests for records.
- 1007.4 Preliminary processing of requests.
- 1007.5 Action on initial requests.
- 1007.6 Time limits for processing initial requests.
- 1007.7 Appeals.
- 1007.8 Action on appeals.
- 1007.9 Fees.
- 1007.10 Waiver of fees.

AUTHORITY: Pub. L. 104-333, 110 Stat. 4097 (16 U.S.C. 460bb note); 5 U.S.C. 552; E.O. 12,600, 52 FR 23781, 3 CFR, 1988 Comp., p. 235.

SOURCE: 63 FR 71774, Dec. 30, 1998, unless otherwise noted.

§ 1007.1 Purpose and scope.

(a) This part contains the procedures for submission to and consideration by the Presidio Trust of requests for records under FOIA. As used in this part, the term “FOIA” means the Freedom of Information Act, 5 U.S.C. 552.

(b) Before invoking the formal procedures set out below, persons seeking records from the Presidio Trust may

find it useful to consult with the Presidio Trust’s FOIA Officer, who can be reached at The Presidio Trust, P.O. Box 29052, San Francisco, CA 94129-0052, Telephone: (415) 561-5300. As used in this part, the term “FOIA Officer” means the employee designated by the Executive Director to process FOIA requests and otherwise supervise the Presidio Trust’s compliance with FOIA, or the alternate employee so designated to perform these duties in the absence of the FOIA Officer.

(c) The procedures in this part do not apply to:

(1) Records published in the FEDERAL REGISTER, the Bylaws of the Presidio Trust, statements of policy and interpretations, and other materials that have been published by the Presidio Trust on its internet website (<http://www.presidiotrust.gov>) or are routinely made available for inspection and copying at the requester’s expense.

(2) Records or information compiled for law enforcement purposes and covered by the disclosure exemption described in §1007.2(c)(7) if:

(i) The investigation or proceeding involves a possible violation of criminal law; and

(ii) There is reason to believe that:

(A) The subject of the investigation or proceeding is not aware of its pendency, and

(B) Disclosure of the existence of the records could reasonably be expected to interfere with enforcement proceedings.

(3) Informant records maintained by the United States Park Police under an informant’s name or personal identifier, if requested by a third party according to the informant’s name or personal identifier, unless the informant’s status as an informant has been officially confirmed.

§ 1007.2 Records available.

(a) *Policy.* It is the policy of the Presidio Trust to make its records available to the public to the greatest extent possible consistent with the purposes of the Presidio Trust Act and the Freedom of Information Act.

(b) *Statutory disclosure requirement.* FOIA requires that the Presidio Trust, on a request from a member of the public submitted in accordance with the



## Presidio Trust

## § 1007.3

procedures in this part, make requested records available for inspection and copying.

(c) *Statutory exemptions.* Exempted from FOIA's statutory disclosure requirement are matters that are:

(1)(i) Specifically authorized under criteria established by an Executive order to be kept secret in the interest of national defense or foreign policy and

(ii) Are in fact properly classified pursuant to such Executive order;

(2) Related solely to the internal personnel rules and practices of an agency;

(3) Specifically exempted from disclosure by statute (other than the Privacy Act), provided that such statute:

(i) Requires that the matters be withheld from the public in such a manner as to leave no discretion on the issue, or

(ii) Establishes particular criteria for withholding or refers to particular types of matters to be withheld;

(4) Trade secrets and commercial or financial information obtained from a person and privileged or confidential;

(5) Inter-agency or intra-agency memorandums or letters which would not be available by law to a party other than an agency in litigation with the agency;

(6) Personnel and medical files and similar files the disclosure of which would constitute a clearly unwarranted invasion of personal privacy;

(7) Records or information compiled for law enforcement purposes, but only to the extent that the production of such law enforcement records or information:

(i) Could reasonably be expected to interfere with enforcement proceedings,

(ii) Would deprive a person of a right to a fair or an impartial adjudication,

(iii) Could reasonably be expected to constitute an unwarranted invasion of personal privacy,

(iv) Could reasonably be expected to disclose the identity of a confidential source, including a State, local, or foreign agency or authority or any private institution which furnished information on a confidential basis, and, in the case of a record or information compiled by a criminal law enforce-

ment authority in the course of a criminal investigation, or by an agency conducting a lawful national security intelligence investigation, information furnished by a confidential source,

(v) Would disclose techniques and procedures for law enforcement investigations or prosecutions or would disclose guidelines for law enforcement investigations or prosecutions if such disclosure could reasonably be expected to risk circumvention of the law, or

(vi) Could reasonably be expected to endanger the life or physical safety of any individual;

(8) Contained in or related to examination, operating, or condition reports prepared by, on behalf of, or for the use of an agency responsible for the regulation or supervision of financial institutions; or

(9) Geological and geophysical information and data, including maps, concerning wells.

(d) *Decisions on requests.* It is the policy of the Presidio Trust to withhold information falling within an exemption only if:

(1) Disclosure is prohibited by statute or Executive order or

(2) Sound grounds exist for invocation of the exemption.

(e) *Disclosure of reasonably segregable nonexempt material.* If a requested record contains material covered by an exemption and material that is not exempt, and it is determined under the procedures in this part to withhold the exempt material, any reasonably segregable nonexempt material shall be separated from the exempt material and released. In such circumstances, the records disclosed in part shall be marked or annotated to show both the amount and the location of the information deleted wherever practicable.

### § 1007.3 Requests for records.

(a) *Submission of requests.* A request to inspect or copy records shall be submitted to the Presidio Trust's FOIA Officer at P.O. Box 29052, San Francisco, CA 94129-0052.

(b) *Form of requests.* (1) Requests under this part shall be in writing and must specifically invoke FOIA.

(2) A request must reasonably describe the records requested. A request

## § 1007.4

reasonably describes the records requested if it will enable an employee of the Presidio Trust familiar with the subject area of the request to locate the record with a reasonable amount of effort. If such information is available, the request should identify the subject matter of the record, the date when it was made, the place where it was made, the person or office that made it, the present custodian of the record, and any other information that will assist in locating the requested record. If the request involves a matter known by the requester to be in litigation, the request should also state the case name and court hearing the case.

(3)(i) A request shall:

(A) Specify the fee category (commercial use, educational institution, noncommercial scientific institution, news media, or other, as defined in §1007.9 of this chapter) in which the requester claims the request falls and the basis of this claim; and

(B) State the maximum amount of fees that the requester is willing to pay or include a request for a fee waiver.

(ii) Requesters are advised that, under §1007.9 (f), (g) and (h), the time for responding to requests may be delayed:

(A) If a requester has not sufficiently identified the fee category applicable to the request;

(B) If a requester has not stated a willingness to pay fees as high as anticipated by the Presidio Trust; or

(C) If a fee waiver request is denied and the requester has not included an alternative statement of willingness to pay fees as high as anticipated by the Presidio Trust.

(4) A request seeking a fee waiver shall, to the extent possible, address why the requester believes that the criteria for fee waivers set out in §1007.10 are met.

(5) To expedite processing, both the envelope containing a request and the face of the request should bear the legend "FREEDOM OF INFORMATION REQUEST."

(c) *Creation of records.* A request may seek only records that are in existence at the time the request is received. A request may not seek records that come into existence after the date on which it is received and may not re-

## 36 CFR Ch. X (7-1-03 Edition)

quire that new records be created in response to the request by, for example, combining or compiling selected items from manual files, preparing a new computer program, or calculating proportions, percentages, frequency distributions, trends or comparisons. In those instances where the Presidio Trust determines that creating a new record will be less burdensome than disclosing large volumes of unassembled material, the Presidio Trust may, in its discretion, agree to creation of a new record as an alternative to disclosing existing records.

### § 1007.4 Preliminary processing of requests.

(a) *Scope of requests.* Unless a request clearly specifies otherwise, requests to the Presidio Trust may be presumed to seek only records of the Presidio Trust.

(b) *Records of other departments and agencies.* (1) If a requested record in the possession of the Presidio Trust originated with another Federal department or agency, the request shall be referred to that agency unless:

(i) The record is of primary interest to the Presidio Trust, for example, because it was developed or prepared pursuant to the Presidio Trust's regulations or request,

(ii) The Presidio Trust is in a better position than the originating agency to assess whether the record is exempt from disclosure, or

(iii) The originating agency is not subject to FOIA.

(2) A request for documents that were classified by another agency shall be referred to that agency.

(c) *Consultation with submitters of commercial and financial information.* (1) If a request seeks a record containing trade secrets or commercial or financial information submitted by a person outside of the Federal government, the Presidio Trust shall provide the submitter with notice of the request whenever:

(i) The submitter has made a good faith designation of the information as commercially or financially sensitive, or

(ii) The Presidio Trust has reason to believe that disclosure of the information may result in commercial or financial injury to the submitter.

## Presidio Trust

## § 1007.5

(2) Where notification of a voluminous number of submitters is required, such notification may be accomplished by posting or publishing the notice in a place reasonably calculated to accomplish notification.

(3) The notice to the submitter shall afford the submitter a reasonable period within which to provide a detailed statement of any objection to disclosure. The submitter's statement shall explain the basis on which the information is claimed to be exempt under FOIA, including a specification of any claim of competitive or other business harm that would result from disclosure. The statement shall also include a certification that the information is confidential, has not been disclosed to the public by the submitter, and is not routinely available to the public from other sources.

(4) If a submitter's statement cannot be obtained within the time limit for processing the request under §1007.6, the requester shall be notified of the delay as provided in §1007.6(f).

(5) Notification to a submitter is not required if:

(i) The Presidio Trust determines, prior to giving notice, that the request for the record should be denied;

(ii) The information has previously been lawfully published or officially made available to the public;

(iii) Disclosure is required by a statute (other than FOIA) or regulation (other than this part);

(iv) Disclosure is clearly prohibited by a statute, as described in §1007.2(c)(3);

(v) The information was not designated by the submitter as confidential when it was submitted, or a reasonable time thereafter, if the submitter was specifically afforded an opportunity to make such a designation; however, a submitter will be notified of a request for information that was not designated as confidential at the time of submission, or a reasonable time thereafter, if there is substantial reason to believe that disclosure of the information would result in competitive harm;

(vi) The designation of confidentiality made by the submitter is obviously frivolous; or

(vii) The information was submitted to the Presidio Trust more than 10 years prior to the date of the request, unless the Presidio Trust has reason to believe that it continues to be confidential.

(6) If a requester brings suit to compel disclosure of information, the submitter of the information will be promptly notified.

### § 1007.5 Action on initial requests.

(a) *Authority.* (1) Requests shall be decided by the FOIA Officer.

(2) A decision to withhold a requested record, to release a record that is exempt from disclosure, or to deny a fee waiver shall be made only after consultation with the General Counsel.

(b) *Form of grant.* (1) When a requested record has been determined to be available, the FOIA Officer shall notify the requester as to when and where the record is available for inspection or, as the case may be, when and how copies will be provided. If fees are due, the FOIA Officer shall state the amount of fees due and the procedures for payment, as described in §1007.9.

(2) The FOIA Officer shall honor a requester's specified preference of form or format of disclosure (e.g., paper, microform, audiovisual materials, or electronic records) if the record is readily available to the Presidio Trust in the requested form or format or if the record is reproducible by the Presidio Trust with reasonable efforts in the requested form or format.

(3) If a requested record (or portion thereof) is being made available over the objections of a submitter made in accordance with §1007.4(c), both the requester and the submitter shall be notified of the decision. The notice to the submitter (a copy of which shall be made available to the requester) shall be forwarded a reasonable number of days prior to the date on which disclosure is to be made and shall include:

(i) A statement of the reasons why the submitter's objections were not sustained;

(ii) A specification of the portions of the record to be disclosed, if the submitter's objections were sustained in part; and

(iii) A specified disclosure date.

## § 1007.6

(4) If a claim of confidentiality has been found frivolous in accordance with §1007.4(c)(5)(vi) and a determination is made to release the information without consultation with the submitter, the submitter of the information shall be notified of the decision and the reasons therefor a reasonable number of days prior to the date on which disclosure is to be made.

(c) *Form of denial.* (1) A decision withholding a requested record shall be in writing and shall include:

(i) A listing of the names and titles or positions of each person responsible for the denial;

(ii) A reference to the specific exemption or exemptions authorizing the withholding;

(iii) If neither a statute nor an Executive order requires withholding, the sound ground for withholding;

(iv) An estimate of the volume of records or information withheld, in number of pages or in some other reasonable form of estimation. This estimate does not need to be provided if the volume is otherwise indicated through deletions on records disclosed in part, or if providing an estimate would harm an interest protected by an applicable exemption; and

(v) A statement that the denial may be appealed and a reference to the procedures in §1007.7 for appeal.

(2) A decision denying a request for failure to reasonably describe requested records or for other procedural deficiency or because requested records cannot be located shall be in writing and shall include:

(i) A description of the basis of the decision;

(ii) A list of the names and titles or positions of each person responsible; and

(iii) A statement that the matter may be appealed and a reference to the procedures in §1007.7 for appeal.

(d) *Expedited processing.* (1) Requests and appeals will be taken out of order and given expedited treatment whenever it is determined by the FOIA Officer that they involve:

(i) Circumstances in which the lack of expedited treatment could reasonably be expected to pose an imminent threat to the life or physical safety of an individual; or

## 36 CFR Ch. X (7-1-03 Edition)

(ii) An urgency to inform the public about an actual or alleged federal government activity, if made by a person primarily engaged in disseminating information.

(2) A request for expedited processing may be made at the time of the initial request for records or at any later time.

(3) A requester who seeks expedited processing must submit a statement, certified to be true and correct to the best of that person's knowledge and belief, explaining in detail the basis for requesting expedited processing.

(4) Within ten calendar days of receiving a request for expedited processing, the FOIA Officer shall decide whether to grant the request for expedited processing and shall notify the requester of the decision. If a request for expedited processing is granted, the underlying FOIA request shall be given priority and shall be processed as soon as practicable. If a request for expedited processing is denied, any appeal of that decision shall be acted on expeditiously.

### §1007.6 Time limits for processing initial requests.

(a) *Basic limit.* Requests for records shall be processed promptly. A determination whether to grant or deny a request shall be made within 20 working days after receipt of a request. This determination shall be communicated immediately to the requester.

(b) *Running of basic time limit.* (1) The 20 working day time limit begins to run when a request meeting the requirements of §1007.3(b) is received at the Presidio Trust.

(2) The running of the basic time limit may be delayed or tolled as explained in §1007.9 (f), (g) and (h) if a requester:

(i) Has not stated a willingness to pay fees as high as are anticipated and has not sought and been granted a full fee waiver, or

(ii) Has not made a required advance payment.

(c) *Extensions of time.* In the following unusual circumstances, the time limit for acting on an initial request may be extended to the extent reasonably necessary to the proper processing of the request, but in no case may the time

## Presidio Trust

## § 1007.8

limit be extended by more than 20 working days:

(1) The need to search for and collect the requested records from facilities or other establishments that are separate from the main office of the Presidio Trust;

(2) The need to search for, collect, and appropriately examine a voluminous amount of separate and distinct records demanded in a single request; or

(3) The need for consultation, which shall be conducted with all practicable speed, with another agency having a substantial interest in the determination of the request.

(d) *Notice of extension.* A requester shall be notified in writing of an extension under paragraph (c) of this section. The notice shall state the reason for the extension and the date on which a determination on the request is expected to be made.

(e) *Treatment of delay as denial.* If no determination has been reached at the end of the 20 working day period for deciding an initial request, or an extension thereof under §1007.6(c), the requester may deem the request denied and may exercise a right of appeal in accordance with §1007.7.

(f) *Notice of delay.* When a determination cannot be reached within the time limit, or extension thereof, the requester shall be notified of the reason for the delay, of the date on which a determination may be expected, and of the right to treat the delay as a denial for purposes of appeal, including a reference to the procedures for filing an appeal in §1007.7.

### § 1007.7 Appeals.

(a) *Right of appeal.* A requester may appeal to the Executive Director when:

(1) Records have been withheld;

(2) A request has been denied for failure to describe requested records or for other procedural deficiency or because requested records cannot be located;

(3) A fee waiver has been denied;

(4) A request has not been decided within the time limits provided in §1007.6; or

(5) A request for expedited processing under §1007.5(d) has been denied.

(b) *Time for appeal.* An appeal must be received at the office of the Presidio

Trust no later than 20 working days after the date of the initial denial, in the case of a denial of an entire request, or 20 working days after records have been made available, in the case of a partial denial.

(c) *Form of appeal.* (1) An appeal shall be initiated by filing a written notice of appeal. The notice shall be accompanied by copies of the original request and the initial denial and should, in order to expedite the appellate process and give the requester an opportunity to present his or her arguments, contain a brief statement of the reasons why the requester believes the initial denial to have been in error.

(2) The appeal shall be addressed to the Executive Director, The Presidio Trust, P.O. Box 29052, San Francisco, CA 94129-0052.

(3) To expedite processing, both the envelope containing a notice of appeal and the face of the notice should bear the legend "FREEDOM OF INFORMATION APPEAL."

### § 1007.8 Action on appeals.

(a) *Authority.* Appeals shall be decided by the Executive Director after consultation with the FOIA Officer and the General Counsel.

(b) *Time limit.* A final determination shall be made within 20 working days after receipt of an appeal meeting the requirements of §1007.7(c).

(c) *Extensions of time.* (1) If the time limit for responding to the initial request for a record was not extended under the provisions of §1007.6(c) or was extended for fewer than 10 working days, the time for processing of the appeal may be extended to the extent reasonably necessary to the proper processing of the appeal, but in no event may the extension, when taken together with any extension made during processing of the initial request, result in an aggregate extension with respect to any one request of more than 10 working days. The time for processing of an appeal may be extended only if one or more of the unusual circumstances listed in §1007.6(c) requires an extension.

(2) The appellant shall be advised in writing of the reasons for the extension

## § 1007.9

## 36 CFR Ch. X (7-1-03 Edition)

and the date on which a final determination on the appeal is expected to be dispatched.

(3) If no determination on the appeal has been reached at the end of the 20 working day period, or the extension thereof, the requester is deemed to have exhausted his administrative remedies, giving rise to a right of review in the United States District Court for the Northern District of California, as specified in 5 U.S.C. 552(a)(4).

(4) When no determination can be reached within the applicable time limit, the appeal will nevertheless continue to be processed. On expiration of the time limit, the requester shall be informed of the reason for the delay, of the date on which a determination may be reached to be dispatched, and of the right to seek judicial review.

(d) *Form of decision.* (1) The final determination on an appeal shall be in writing and shall state the basis for the determination. If the determination is to release the requested records or portions thereof, the FOIA Officer shall immediately make the records available. If the determination upholds in whole or part the initial denial of a request for records, the determination shall advise the requester of the right to obtain judicial review in the U.S. District Court for the Northern District of California and shall set forth the names and titles or positions of each person responsible for the denial.

(2) If a requested record (or portion thereof) is being made available over the objections of a submitter made in accordance with §1007.4(c), the submitter shall be provided notice as described in §1007.5(b)(3).

### § 1007.9 Fees.

(a) *Policy.* (1) Unless waived pursuant to the provisions of §1007.10, fees for responding to FOIA requests shall be charged in accordance with the provisions of this section and the current schedule of charges determined by the Executive Director and published in the compilation provided under §1001.7(b) of this chapter. Such charges shall be set at the level necessary to recoup the full allowable direct costs to the Trust.

(2) Fees shall not be charged if the total amount chargeable does not ex-

ceed the costs of routine collection and processing of the fee. The Trust shall periodically determine the cost of routine collection and processing of a fee and publish such amount in the compilation provided under §1001.7(b) of this chapter.

(3) Where there is a reasonable basis to conclude that a requester or group of requesters acting in concert has divided a request into a series of requests on a single subject or related subjects to avoid assessment of fees, the requests may be aggregated and fees charged accordingly.

(4) Fees shall be charged to recover the full costs of providing such services as certifying that records are true copies or sending records by a method other than regular mail, when the Trust elects to provide such services.

(5) The following definitions shall apply to this part:

(i) The term *search* includes all time spent looking for material that is responsive to a request, including page-by-page or line-by-line identification of material within documents or databases. Searches shall be undertaken in the most efficient and least expensive manner possible, consistent with the Presidio Trust's obligations under FOIA and other applicable laws.

(ii) The term *duplication* refers to the process of making a copy of a record necessary to respond to a FOIA request. Such copies can take the form of paper copy, microform, audio-visual materials, or machine-readable documentation (e.g., magnetic tape or disk), among others. The copy provided shall be in a form that is reasonably usable by requesters.

(iii) A *commercial use request* is a request from or on behalf of a person who seeks information for a use or purpose that furthers the commercial, trade, or profit interests of the requester or the person on whose behalf the request is made. The intended use of records may be determined on the basis of information submitted by a requester and from reasonable inferences based on the identity of the requester and any other available information.

(iv) An *educational institution* is a preschool, a public or private elementary or secondary school, an institution of

## Presidio Trust

## § 1007.9

graduate higher education, an institution of undergraduate higher education, an institution of professional education, or an institution of vocational education, which operates a program or programs of scholarly research.

(v) A *noncommercial scientific institution* is an institution that is not operated for commerce, trade or profit and that is operated solely for the purpose of conducting scientific research the results of which are not intended to promote any particular product or industry.

(vi) A *representative of the news media* is any person actively gathering news for an entity that is organized and operated to publish or broadcast news to the public. The term "news" means information that is about current events or that is (or would be) of current interest to the public. Examples of news media entities include, but are not limited to, television or radio stations broadcasting to the public at large, and publishers of periodicals (but only in those instances when they can qualify as disseminators of "news") who make their products available for purchase or subscription by the general public. As traditional methods of news delivery evolve (e.g., electronic dissemination of newspapers through telecommunications services), such alternative media would be included in this category. Free-lance journalists may be considered representatives of the news media if they demonstrate a solid basis for expecting publication through a news organization, even though not actually employed by it. A publication contract or past record of publication, or evidence of a specific free-lance assignment from a news organization may indicate a solid basis for expecting publication.

(b) *Commercial use requests.* (1) A requester seeking records for commercial use shall be charged fees for costs incurred in document search and review (even if the search and review fails to locate records that are not exempt from disclosure) and duplication.

(2) A commercial use requester may not be charged fees for time spent resolving legal and policy issues affecting access to requested records.

(c) *Educational and noncommercial scientific institution requests.* (1) A requester seeking records under the auspices of an educational institution in furtherance of scholarly research or a noncommercial scientific institution in furtherance of scientific research shall be charged for document duplication, except that the first 100 pages of paper copies (or the equivalent cost thereof if the records are in some other form) shall be provided without charge.

(2) Such requesters may not be charged fees for costs incurred in:

- (i) Searching for requested records,
- (ii) Examining requested records to determine whether they are exempt from mandatory disclosure,
- (iii) Deleting reasonably segregable exempt matter,
- (iv) Monitoring the requester's inspection of agency records, or
- (v) Resolving legal and policy issues affecting access to requested records.

(d) *News media requests.* (1) A representative of the news media shall be charged for document duplication, except that the first 100 pages of paper copies (or the equivalent cost thereof if the records are in some other form) shall be provided without charge.

(2) Representatives of the news media may not be charged fees for costs incurred in:

- (i) Searching for requested records,
- (ii) Examining requested records to determine whether they are exempt from mandatory disclosure,
- (iii) Deleting reasonably segregable exempt matter,
- (iv) Monitoring the requester's inspection of agency records, or
- (v) Resolving legal and policy issues affecting access to requested records.

(e) *Other requests.* (1) A requester not covered by paragraphs (b), (c), or (d) of this section shall be charged fees for document search (even if the search fails to locate records that are not exempt from disclosure) and duplication, except that the first two hours of search time and the first 100 pages of paper copies (or the equivalent cost thereof if the records are in some other form) shall be provided without charge.

(2) Such requesters may not be charged for costs incurred in:

## § 1007.10

(i) Examining requested records to determine whether they are exempt from disclosure,

(ii) Deleting reasonably segregable exempt matter,

(iii) Monitoring the requester's inspection of agency records, or

(iv) Resolving legal and policy issues affecting access to requested records.

(f) *Requests for clarification.* Where a request does not provide sufficient information to determine whether it is covered by paragraph (b), (c), (d), or (e) of this section, the requester should be asked to provide additional clarification. If it is necessary to seek such clarification, the request may be deemed to have not been received for purposes of the time limits established in §1007.6 until the clarification is received. Requests to requesters for clarification shall be made promptly.

(g) *Notice of anticipated fees.* Where a request does not state a willingness to pay fees as high as anticipated by the Presidio Trust, and the requester has not sought and been granted a full waiver of fees under §1007.10, the request may be deemed to have not been received for purposes of the time limits established in §1007.6 until the requester has been notified of and agrees to pay the anticipated fee. Advice to requesters with respect to anticipated fees shall be provided promptly.

(h) *Advance payment.* (1) Where it is anticipated that allowable fees are likely to exceed \$250.00, the requester may be required to make an advance payment of the entire fee before processing of his or her request.

(2) Where a requester has previously failed to pay a fee within 30 days of the date of billing, processing of any request from that requester shall ordinarily be suspended until the requester pays any amount still owed, including applicable interest, and makes advance payment of allowable fees anticipated in connection with the request.

(3) Advance payment of fees may not be required except as described in paragraphs (h) (1) and (2) of this section.

(4) Issuance of a notice requiring payment of overdue fees or advance payment shall toll the time limit in §1007.6 until receipt of payment.

(i) *Form of payment.* Payment of fees should be made by check or money

## 36 CFR Ch. X (7-1-03 Edition)

order payable to the Presidio Trust. Where appropriate, the official responsible for handling a request may require that payment by check be made in the form of a certified check.

(j) *Billing procedures.* A bill for collection shall be prepared for each request that requires collection of fees.

(k) *Collection of fees.* The bill for collection or an accompanying letter to the requester shall include a statement that interest will be charged in accordance with the Debt Collection Act of 1982, 31 U.S.C. 3717, and implementing regulations, 4 CFR 102.13, if the fees are not paid within 30 days of the date of the bill for collection is mailed or hand-delivered to the requester. This requirement does not apply if the requester is a unit of State or local government. Other authorities of the Debt Collection Act of 1982 shall be used, as appropriate, to collect the fees.

### § 1007.10 Waiver of fees.

(a) *Statutory fee waiver.* Documents shall be furnished without charge or at a charge reduced below the fees chargeable under §1007.9 if disclosure of the information is in the public interest because it:

(1) Is likely to contribute significantly to public understanding of the operations or activities of the government and

(2) Is not primarily in the commercial interest of the requester.

(b) *Elimination or reduction of fees.* Ordinarily, in the circumstances where the criteria of paragraph (a) of this section are met, fees will be reduced by twenty-five percent from the fees otherwise chargeable to the requester. In exceptional circumstances, and with the approval of the Executive Director, fees may be reduced below this level or waived entirely.

(c) *Notice of denial.* If a requested statutory fee waiver or reduction is denied, the requester shall be notified in writing. The notice shall include:

(1) A statement of the basis on which the waiver or reduction has been denied;

(2) A listing of the names and titles or positions of each person responsible for the denial; and

(3) A statement that the denial may be appealed to the Executive Director



## Presidio Trust

## § 1008.2

and a description of the procedures in § 1007.7 for appeal.

### PART 1008—REQUESTS UNDER THE PRIVACY ACT

Sec.

- 1008.1 Purpose and scope.
- 1008.2 Definitions.
- 1008.3 Records subject to the Privacy Act.
- 1008.4 Standards for maintenance of records subject to the Privacy Act.
- 1008.5 Federal Register notices describing systems of records.
- 1008.6 Assuring integrity of records.
- 1008.7 Conduct of employees.
- 1008.8 Government contracts.
- 1008.9 Disclosure of records.
- 1008.10 Accounting for disclosures.
- 1008.11 Requests for notification of existence of records: Submission.
- 1008.12 Requests for notification of existence of records: Action on.
- 1008.13 Requests for access to records.
- 1008.14 Requests for access to records: Submission.
- 1008.15 Requests for access to records: Initial decision.
- 1008.16 Requests for notification of existence of records and for access to records: Appeals.
- 1008.17 Requests for access to records: Special situations.
- 1008.18 Amendment of records.
- 1008.19 Petitions for amendment: Submission and form.
- 1008.20 Petitions for amendment: Processing and initial decision.
- 1008.21 Petitions for amendment: Time limits for processing.
- 1008.22 Petitions for amendment: Appeals.
- 1008.23 Petitions for amendment: Action on appeals.
- 1008.24 Statements of disagreement.

AUTHORITY: Pub. L. 104-333, 110 Stat. 4097 (16 U.S.C. 460bb note); 5 U.S.C. 552a.

SOURCE: 63 FR 71779, Dec. 30, 1998, unless otherwise noted.

#### § 1008.1 Purpose and scope.

This part contains the regulations of the Presidio Trust implementing section 3 of the Privacy Act. Sections 1008.3 through 1008.10 describe the procedures and policies of the Presidio Trust concerning maintenance of records which are subject to the Privacy Act. Sections 1008.11 through 1008.17 describe the procedure under which individuals may determine whether systems of records subject to the Privacy Act contain records relating to them and the procedure under

which they may seek access to existing records. Sections 1008.18 through 1008.24 describe the procedure under which individuals may petition for amendment of records subject to the Privacy Act relating to them.

#### § 1008.2 Definitions.

The following terms have the following meanings as used in this part:

*Individual* means a citizen of the United States or an alien lawfully admitted for permanent residence.

*Maintain* means maintain, collect, use or disseminate.

*Privacy Act* means 5 U.S.C. 552a.

*Privacy Act Officer* means the Presidio Trust official charged with responsibility for carrying out the functions assigned in this part.

*Record* means any item, collection, or grouping of information about an individual that is maintained by the Presidio Trust, including, but not limited to, education, financial transactions, medical history, and criminal or employment history and that contains the individual's name, or the identifying number, symbol, or other identifying particular assigned to the individual, such as a finger or voice print, or a photograph. Related definitions include:

(1) *System of records* means a group of any records under the control of the Presidio Trust from which information is retrieved by the name of the individual or by some identifying number, symbol, or other identifying particular assigned to the individual.

(2) *Medical records* means records which relate to the identification, prevention, cure or alleviation of any disease, illness or injury including psychological disorders, alcoholism and drug addiction.

(3) *Personnel records* means records used for personnel management programs or processes such as staffing, employee development, retirement, and grievances and appeals.

(4) *Statistical records* means records in a system of records maintained for statistical research or reporting purposes only and not used in whole or in part in making any determination about an identifiable individual.

### § 1008.3

*Routine use* means a use of a record for a purpose which is compatible with the purpose for which it was collected.

*System manager* means the official designated in a system notice as having administrative responsibility for a system of records.

*System notice* means the notice describing a system of records required by 5 U.S.C. 552a(e)(4) to be published in the FEDERAL REGISTER upon establishment or revision of the system of records.

### § 1008.3 Records subject to the Privacy Act.

The Privacy Act applies to all records which the Presidio Trust maintains in a system of records.

### § 1008.4 Standards for maintenance of records subject to the Privacy Act.

(a) *Content of records.* Records subject to the Privacy Act shall contain only such information about an individual as is relevant and necessary to accomplish a purpose of the Presidio Trust required to be accomplished by statute or Executive Order of the President.

(b) *Standards of accuracy.* Records subject to the Privacy Act which are used in making any determination about any individual shall be maintained with such accuracy, relevance, timeliness, and completeness as is reasonably necessary to assure fairness to the individual in making the determination.

(c) *Collection of information.* (1) Information which may be used in making determinations about an individual's rights, benefits, and privileges under Federal programs shall, to the greatest extent practicable, be collected directly from that individual.

(2) In deciding whether collection of information from an individual, as opposed to a third party source, is practicable, the following factors, among others, may be considered:

(i) Whether the nature of the information sought is such that it can only be obtained from a third party;

(ii) Whether the cost of collecting the information from the individual is unreasonable when compared with the cost of collecting it from a third party;

(iii) Whether there is a risk that information collected from third parties,

### 36 CFR Ch. X (7-1-03 Edition)

if inaccurate, could result in an adverse determination to the individual concerned;

(iv) Whether the information, if supplied by the individual, would have to be verified by a third party; or (v) Whether provisions can be made for verification, by the individual, of information collected from third parties.

(d) *Advice to individuals concerning uses of information.* (1) Each individual who is asked to supply information about him or herself which will be added to a system of records shall be informed of the basis for requesting the information, how it may be used, and what the consequences, if any, are of not supplying the information.

(2) At a minimum, the notice to the individual must state:

(i) The authority (whether granted by statute or Executive Order of the President) which authorizes the solicitation of the information and whether disclosure of such information is mandatory or voluntary;

(ii) The principal purpose or purposes for which the information is intended to be used;

(iii) The routine uses which may be made of the information; and

(iv) The effects on the individual, if any, of not providing all or any part of the requested information.

(3)(i) When information is collected on a standard form, the notice to the individual shall be provided on the form, on a tear-off sheet attached to the form, or on a separate sheet, whichever is most practical.

(ii) When information is collected by an interviewer, the interviewer shall provide the individual with a written notice which the individual may retain. If the interview is conducted by telephone, however, the interviewer may summarize the notice for the individual and need not provide a copy to the individual unless the individual requests a copy.

(iii) An individual may be asked to acknowledge, in writing, that the notice required by this section has been provided.

(e) *Records concerning activity protected by the First Amendment.* No record may be maintained describing how any individual exercises rights guaranteed

## Presidio Trust

## § 1008.9

by the First Amendment to the Constitution unless the maintenance of the record is:

(1) Expressly authorized by statute or by the individual about whom the record is maintained; or

(2) Pertinent to and within the scope of an authorized law enforcement activity.

### § 1008.5 Federal Register notices describing systems of records.

The Privacy Act requires publication of a notice in the FEDERAL REGISTER describing each system of records subject to the Privacy Act. Such notice will be published prior to the establishment or a revision of the system of records. 5 U.S.C. 552a(e)(4).

### § 1008.6 Assuring integrity of records.

(a) *Statutory requirement.* The Privacy Act requires that records subject to the Privacy Act be maintained with appropriate administrative, technical and physical safeguards to insure the security and confidentiality of records and to protect against any anticipated threats or hazards to their security or integrity which could result in substantial harm, embarrassment, inconvenience, or unfairness to any individual on whom information is maintained, 5 U.S.C. 552a(e)(10).

(b) *Records security.* Whether maintained in physical or electronic form, records subject to the Privacy Act shall be maintained in a secure manner commensurate with the sensitivity of the information contained in the system of records. The Privacy Act Officer will periodically review these security measures to ensure their adequacy.

### § 1008.7 Conduct of employees.

(a) *Handling of records subject to the Privacy Act.* Employees whose duties require handling of records subject to the Privacy Act shall, at all times, take care to protect the integrity, security and confidentiality of these records.

(b) *Disclosure of records.* No employee of the Presidio Trust may disclose records subject to the Privacy Act unless disclosure is permitted under § 1008.9 or is to the individual to whom the record pertains.

(c) *Alteration of records.* No employee of the Presidio Trust may alter or destroy a record subject to the Privacy Act unless such alteration or destruction is:

(1) Properly undertaken in the course of the employee's regular duties; or

(2) Required by a decision under §§ 1008.18 through 1008.23 or the decision of a court of competent jurisdiction.

### § 1008.8 Government contracts.

(a) *Required contract provisions.* When a contract provides for the operation by or on behalf of the Presidio Trust of a system of records to accomplish a Presidio Trust function, the contract shall, consistent with the Presidio Trust's authority, cause the requirements of 5 U.S.C. 552a and the regulations contained in this part to be applied to such system.

(b) *System manager.* A regular employee of the Presidio Trust will be the manager for a system of records operated by a contractor.

### § 1008.9 Disclosure of records.

(a) *Prohibition of disclosure.* No record contained in a system of records may be disclosed by any means of communication to any person, or to another agency, except pursuant to a written request by, or with the prior written consent of, the individual to whom the record pertains.

(b) *General exceptions.* The prohibition contained in paragraph (a) of this section does not apply where disclosure of the record would be:

(1) To those officers or employees of the Presidio Trust who have a need for the record in the performance of their duties; or

(2) Required by the Freedom of Information Act, 5 U.S.C. 552.

(c) *Specific exceptions.* The prohibition contained in paragraph (a) of this section does not apply where disclosure of the record would be:

(1) For a routine use which has been described in a system notice published in the FEDERAL REGISTER;

(2) To the Bureau of the Census for purposes of planning or carrying out a census or survey or related activity pursuant to the provisions of Title 13, U.S. Code.

§ 1008.10

36 CFR Ch. X (7-1-03 Edition)

(3) To a recipient who has provided the system manager responsible for the system in which the record is maintained with advance adequate written assurance that the record will be used solely as a statistical research or reporting record, and the record is to be transferred in a form that is not individually identifiable;

(4) To the National Archives and Records Administration as a record which has sufficient historical or other value to warrant its continued preservation by the U.S. Government, or for evaluation by the Archivist of the United States or the designee of the Archivist to determine whether the record has such value;

(5) To another agency or to an instrumentality of any governmental jurisdiction within or under the control of the United States for a civil or criminal law enforcement activity if the activity is authorized by law, and if the head of the agency or instrumentality has made a written request to the Presidio Trust specifying the particular portion desired and the law enforcement activity for which the record is sought;

(6) To a person pursuant to a showing of compelling circumstances affecting the health or safety of an individual if upon such disclosure notification is transmitted to the last known address of such individual;

(7) To either House of Congress, or, to the extent of matter within its jurisdiction, any committee or subcommittee thereof, any joint committee of Congress or subcommittee of any such joint committee;

(8) To the Comptroller General, or any of his authorized representatives, in the course of the performance of the duties of the General Accounting Office;

(9) Pursuant to the order of a court of competent jurisdiction; or

(10) To a consumer reporting agency in accordance with section 3(d) of the Federal Claims Collection Act of 1966, as amended (31 U.S.C. 3711(f)).

(d) *Reviewing records prior to disclosure.* (1) Prior to any disclosure of a record about an individual, unless disclosure is required by the Freedom of Information Act, reasonable efforts shall be made to ensure that the

records are accurate, complete, timely and relevant for agency purposes.

(2) When a record is disclosed in connection with a Freedom of Information Act request made under this part and it is appropriate and administratively feasible to do so, the requester shall be informed of any information known to the Presidio Trust indicating that the record may not be fully accurate, complete, or timely.

§ 1008.10 **Accounting for disclosures.**

(a) *Maintenance of an accounting.* (1) Where a record is disclosed to any person, or to another agency, under any of the specific exceptions provided by § 1008.9(c), an accounting shall be made.

(2) The accounting shall record:

(i) The date, nature, and purpose of each disclosure of a record to any person or to another agency; and

(ii) The name and address of the person or agency to whom the disclosure was made.

(3) Accountings prepared under this section shall be maintained for at least five years or the life of the record, whichever is longer, after the disclosure for which the accounting is made.

(b) *Access to accountings.* (1) Except for accountings of disclosures made under § 1008.9(c)(5), accountings of all disclosures of a record shall be made available to the individual to whom the record relates at the individual's request.

(2) An individual desiring access to an accounting of disclosures of a record pertaining to the individual shall submit a request by following the procedures of § 1008.13.

(c) *Notification of disclosure.* When a record is disclosed pursuant to § 1008.9(c)(9) as the result of the order of a court of competent jurisdiction, reasonable efforts shall be made to notify the individual to whom the record pertains as soon as the order becomes a matter of public record.

§ 1008.11 **Request for notification of existence of records: Submission.**

(a) *Submission of requests.* (1) Individuals desiring to determine under the Privacy Act whether a system of records contains records pertaining to them shall address inquiries to the Privacy Act Officer, The Presidio Trust,

## Presidio Trust

## § 1008.13

P.O. Box 29052, San Francisco, CA 94129-0052, unless the system notice describing the system prescribes or permits submission to some other official or officials.

(2) Individuals desiring to determine whether records pertaining to them are maintained in two or more systems shall make a separate inquiry concerning each system.

(b) *Form of request.* (1) An inquiry to determine whether a system of records contains records pertaining to an individual shall be in writing.

(2) To expedite processing, both the envelope containing a request and the face of the request should bear the legend "PRIVACY ACT INQUIRY."

(3) The request shall state that the individual is seeking information concerning records pertaining to him or herself and shall supply such additional identifying information, if any, as is called for in the system notice describing the system.

(4) Individuals who have reason to believe that information pertaining to them may be filed under a name other than the name they are currently using (e.g., maiden name), shall include such information in the request.

### §1008.12 Requests for notification of existence of records: Action on.

(a) *Decisions on request.* (1) Individuals inquiring to determine whether a system of records contains records pertaining to them shall be promptly advised whether the system contains records pertaining to them unless:

(i) The records were compiled in reasonable anticipation of a civil action or proceeding; or

(ii) The system of records is one which has been excepted from the notification provisions of the Privacy Act by rulemaking.

(2) If the records were compiled in reasonable anticipation of a civil action or proceeding or the system of records is one which has been excepted from the notification provisions of the Privacy Act by rulemaking, the individuals will be promptly notified that they are not entitled to notification of whether the system contains records pertaining to them.

(b) *Authority to deny requests.* A decision to deny a request for notification

of the existence of records shall be made by the Privacy Act officer in consultation with the General Counsel.

(c) *Form of decision.* (1) No particular form is required for a decision informing individuals whether a system of records contains records pertaining to them.

(2) A decision declining to inform an individual whether or not a system of records contains records pertaining to him or her shall be in writing and shall:

(i) State the basis for denial of the request;

(ii) Advise the individual that an appeal of the declination may be made to the Executive Director pursuant to §1008.16 by writing to the Executive Director, The Presidio Trust, P.O. Box 29052, San Francisco, CA 94129-0052; and

(iii) State that the appeal must be received by the foregoing official within 20 working days of the date of the decision.

(3) If the decision declining a request for notification of the existence of records involves records which fall under the jurisdiction of another agency, the individual shall be informed in a written response which shall:

(i) State the reasons for the denial;

(ii) Include the name, position title, and address of the official responsible for the denial; and (iii) Advise the individual that an appeal of the declination may be made only to the appropriate official of the relevant agency, and include that official's name, position title, and address.

(4) Copies of decisions declining a request for notification of the existence of records made pursuant to paragraphs (c)(2) and (c)(3) of this section shall be provided to the Privacy Act Officer.

### §1008.13 Requests for access to records.

The Privacy Act permits individuals, upon request, to gain access to their records or to any information pertaining to them which is contained in a system and to review the records and have a copy made of all or any portion thereof in a form comprehensive to them. 5 U.S.C. 552a(d)(1). A request for access shall be submitted in accordance with the procedures in this part.

**§ 1008.14**

**§ 1008.14 Requests for access to records: Submission.**

(a) *Submission of requests.* (1) Requests for access to records shall be submitted to the Privacy Act Officer unless the system notice describing the system prescribes or permits submission to some other official or officials.

(2) Individuals desiring access to records maintained in two or more separate systems shall submit a separate request for access to the records in each system.

(b) *Form of request.* (1) A request for access to records subject to the Privacy Act shall be in writing and addressed to Privacy Act Officer, The Presidio Trust, P.O. Box 29052, San Francisco, CA 94129-0052.

(2) To expedite processing, both the envelope containing a request and the face of the request should bear the legend "PRIVACY ACT REQUEST FOR ACCESS."

(3) Requesters shall specify whether they seek all of the records contained in the system which relate to them or only some portion thereof. If only a portion of the records which relate to the individual are sought, the request shall reasonably describe the specific record or records sought.

(4) If the requester seeks to have copies of the requested records made, the request shall state the maximum amount of copying fees which the requester is willing to pay. A request which does not state the amount of fees the requester is willing to pay will be treated as a request to inspect the requested records. Requesters are further notified that under § 1008.15(d) the failure to state willingness to pay fees as high as are anticipated by the Presidio Trust will delay processing of a request.

(5) The request shall supply such identifying information, if any, as is called for in the system notice describing the system.

(6) Requests failing to meet the requirements of this paragraph shall be returned to the requester with a written notice advising the requester of the deficiency in the request.

**36 CFR Ch. X (7-1-03 Edition)**

**§ 1008.15 Requests for access to records: Initial decision.**

(a) *Decisions on requests.* A request made under this part for access to a record shall be granted promptly unless the record:

(1) Was compiled in reasonable anticipation of a civil action or proceeding; or

(2) Is contained in a system of records which has been excepted from the access provisions of the Privacy Act by rulemaking.

(b) *Authority to deny requests.* A decision to deny a request for access under this part shall be made by the Privacy Act Officer in consultation with the General Counsel.

(c) *Form of decision.* (1) No particular form is required for a decision granting access to a record. The decision shall, however, advise the individual requesting the record as to where and when the record is available for inspection or, as the case may be, where and when copies will be available. If fees are due under § 1008.15(d), the individual requesting the record shall also be notified of the amount of fees due or, if the exact amount has not been determined, the approximate amount of fees due.

(2) A decision denying a request for access, in whole or part, shall be in writing and shall:

(i) State the basis for denial of the request;

(ii) Contain a statement that the denial may be appealed to the Executive Director pursuant to § 1008.16 by writing to the Executive Director, The Presidio Trust, P.O. Box 29052, San Francisco, CA 94129-0052; and (iii) State that the appeal must be received by the foregoing official within 20 working days of the date of the decision.

(3) If the decision denying a request for access involves records which fall under the jurisdiction of another agency, the individual shall be informed in a written response which shall:

(i) State the reasons for the denial;

(ii) Include the name, position title, and address of the official responsible for the denial; and

(iii) Advise the individual that an appeal of the declination may be made only to the appropriate official of the relevant agency, and include that official's name, position title, and address.

## Presidio Trust

## § 1008.18

(4) Copies of decisions denying requests for access made pursuant to paragraphs (c)(2) and (c)(3) of this section will be provided to the Privacy Act Officer.

(d) *Fees.* (1) No fees may be charged for the cost of searching for or reviewing a record in response to a request made under §1008.14.

(2) Unless the Privacy Act Officer determines that reduction or waiver of fees is appropriate, fees for copying a record in response to a request made under §1008.14 shall be charged in accordance with the provisions of this section and the current schedule of charges determined by the Executive Director and published in the compilation provided under §1001.7(b) of this chapter. Such charges shall be set at the level necessary to recoup the full allowable direct costs to the Trust.

(3) Where it is anticipated that fees chargeable in connection with a request will exceed the amount the person submitting the request has indicated a willingness to pay, the Privacy Act Officer shall notify the requester and shall not complete processing of the request until the requester has agreed, in writing, to pay fees as high as are anticipated.

### §1008.16 Requests for notification of existence of records and for access to records: Appeals.

(a) *Right of appeal.* Except for appeals pertaining to records under the jurisdiction of another agency, individuals who have been notified that they are not entitled to notification of whether a system of records contains records pertaining to them or have been denied access, in whole or part, to a requested record may appeal to the Executive Director.

(b) *Time for appeal.* (1) An appeal must be received by the Executive Director no later than 20 working days after the date of the initial decision on a request.

(2) The Executive Director may, for good cause shown, extend the time for submission of an appeal if a written request for additional time is received within 20 working days of the date of the initial decision on the request.

(c) *Form of appeal.* (1) An appeal shall be in writing and shall attach copies of

the initial request and the decision on the request.

(2) The appeal shall contain a brief statement of the reasons why the appellant believes the decision on the initial request to have been in error.

(3) The appeal shall be addressed to the Executive Director, The Presidio Trust, P.O. Box 29052, San Francisco, CA 94129-0052.

(d) *Action on appeals.* (1) Appeals from decisions on initial requests made pursuant to §§1008.11 and 1008.14 shall be decided for the Presidio Trust by the Executive Director after consultation with the General Counsel.

(2) The decision on an appeal shall be in writing and shall state the basis for the decision.

### §1008.17 Requests for access to records: Special situations.

(a) *Medical records.* (1) Medical records shall be disclosed to the individual to whom they pertain unless it is determined, in consultation with a medical doctor, that disclosure should be made to a medical doctor of the individual's choosing.

(2) If it is determined that disclosure of medical records directly to the individual to whom they pertain could have an adverse effect on that individual, the individual may designate a medical doctor to receive the records and the records will be disclosed to that doctor.

(b) *Inspection in presence of third party.* (1) Individuals wishing to inspect records pertaining to them which have been opened for their inspection may, during the inspection, be accompanied by a person of their own choosing.

(2) When such a procedure is deemed appropriate, individuals to whom the records pertain may be required to furnish a written statement authorizing discussion of their records in the accompanying person's presence.

### §1008.18 Amendment of records.

The Privacy Act permits individuals to request amendment of records pertaining to them if they believe the records are not accurate, relevant, timely or complete. 5 U.S.C. 552a(d)(2). A request for amendment of a record shall be submitted in accordance with the procedures in this part.

**§ 1008.19 Petitions for amendment: Submission and form.**

(a) *Submission of petitions for amendment.* (1) A request for amendment of a record shall be submitted to the Privacy Act Officer unless the system notice describing the system prescribes or permits submission to a different official or officials. If an individual wishes to request amendment of records located in more than one system, a separate petition must be submitted with respect to each system.

(2) A petition for amendment of a record may be submitted only if the individual submitting the petition has previously requested and been granted access to the record and has inspected or been given a copy of the record.

(b) *Form of petition.* (1) A petition for amendment shall be in writing and shall specifically identify the record for which amendment is sought.

(2) The petition shall state, in detail, the reasons why the petitioner believes the record, or the objectionable portion thereof, is not accurate, relevant, timely or complete. Copies of documents or evidence relied upon in support of these reasons shall be submitted with the petition.

(3) The petition shall state, specifically and in detail, the changes sought in the record. If the changes involve re-writing the record or portions thereof or involve adding new language to the record, the petition shall propose specific language to implement the changes.

**§ 1008.20 Petitions for amendment: Processing and initial decision.**

(a) *Decisions on petitions.* In reviewing a record in response to a petition for amendment, the accuracy, relevance, timeliness and completeness of the record shall be assessed against the criteria set out in § 1008.4.

(b) *Authority to decide.* A decision on a petition for amendment shall be made by the Privacy Act Officer in consultation with the General Counsel.

(c) *Acknowledgment of receipt.* Unless processing of a petition is completed within ten working days, the receipt of the petition for amendment shall be acknowledged in writing by the Privacy Act Officer.

(d) *Inadequate petitions.* (1) If a petition does not meet the requirements of § 1008.19, the petitioner shall be so advised and shall be told what additional information must be submitted to meet the requirements of § 1008.19.

(2) If the petitioner fails to submit the additional information within a reasonable time, the petition may be rejected. The rejection shall be in writing and shall meet the requirements of paragraph (e) of this section.

(e) *Form of decision.* (1) A decision on a petition for amendment shall be in writing and shall state concisely the basis for the decision.

(2) If the petition for amendment is rejected, in whole or part, the petitioner shall be informed in a written response which shall:

(i) State concisely the basis for the decision;

(ii) Advise the petitioner that the rejection may be appealed to the Executive Director, The Presidio Trust, P.O. Box 29052, San Francisco, CA 94129-0052; and

(iii) State that the appeal must be received by the foregoing official within 20 working days of the decision.

(3) If the petition for amendment involves records which fall under the jurisdiction of another agency and is rejected, in whole or part, the petitioner shall be informed in a written response which shall:

(i) State concisely the basis for the decision;

(ii) Include the name, position title, and address of the official responsible for the denial; and

(iii) Advise the individual that an appeal of the rejection may be made only to the appropriate official of the relevant agency, and include that official's name, position title, and address.

(4) Copies of rejections of petitions for amendment made pursuant to paragraphs (e)(2) and (e)(3) of this section will be provided to the Privacy Act Officer.

(f) *Implementation of initial decision.* If a petition for amendment is accepted, in whole or part, the system manager maintaining the record shall:

(1) Correct the record accordingly and,

(2) Where an accounting of disclosures has been made pursuant to



## Presidio Trust

## § 1008.23

§1008.10, advise all previous recipients of the record that the correction was made and the substance of the correction.

### § 1008.21 Petitions for amendment: Time limits for processing.

(a) *Acknowledgment of receipt.* The acknowledgment of receipt of a petition required by §1008.20(c) shall be dispatched not later than ten working days after receipt of the petition by the Privacy Act Officer, unless a decision on the petition has been previously dispatched.

(b) *Decision on petition.* A petition for amendment shall be processed promptly. A determination whether to accept or reject the petition for amendment shall be made within 30 working days after receipt of the petition by the system manager responsible for the system containing the challenged record.

(c) *Suspension of time limit.* The 30 working day time limit for a decision on a petition shall be suspended if it is necessary to notify the petitioner, pursuant to §1008.20(d), that additional information in support of the petition is required. Running of the 30 working day time limit shall resume on receipt of the additional information by the system manager responsible for the system containing the challenged record.

(d) *Extensions of time.* (1) The 30 working day time limit for a decision on a petition may be extended if the Privacy Act Officer determines that an extension is necessary for one of the following reasons:

(i) A decision on the petition requires analysis of voluminous record or records;

(ii) Some or all of the challenged records must be collected from facilities other than the facility at which the Privacy Act Officer is located; or

(iii) Some or all of the challenged records are of concern to another agency of the Federal Government whose assistance and views are being sought in processing the request.

(2) If the official responsible for making a decision on the petition determines that an extension is necessary, the official shall promptly inform the petitioner of the extension and the

date on which a decision is expected to be dispatched.

### § 1008.22 Petitions for amendment: Appeals.

(a) *Right of appeal.* Except for appeals pertaining to records under the jurisdiction of another agency, where a petition for amendment has been rejected in whole or in part, the individual submitting the petition may appeal the denial to the Executive Director.

(b) *Time for appeal.* (1) An appeal must be received no later than 20 working days after the date of the decision on a petition.

(2) The Executive Director may, for good cause shown, extend the time for submission of an appeal if a written request for additional time is received within 20 working days of the date of the decision on a petition.

(c) *Form of appeal.* (1) An appeal shall be in writing and shall attach copies of the initial petition and the decision on that petition.

(2) The appeal shall contain a brief statement of the reasons why the appellant believes the decision on the petition to have been in error.

(3) The appeal shall be addressed to the Executive Director, The Presidio Trust, P.O. Box 29052, San Francisco, CA 94129-0052.

### § 1008.23 Petitions for amendment: Action on appeals.

(a) *Authority.* Appeals from decisions on initial petitions for amendment shall be decided by the Executive Director, in consultation with the General Counsel.

(b) *Time limit.* (1) A final determination on any appeal shall be made within 30 working days after receipt of the appeal.

(2) The 30 working day period for decision on an appeal may be extended, for good cause shown, by the Executive Director. If the 30 working day period is extended, the individual submitting the appeal shall be notified of the extension and of the date on which a determination on the appeal is expected to be dispatched.

(c) *Form of decision.* (1) The final determination on an appeal shall be in writing and shall state the basis for the determination.

**§ 1008.24**

(2) If the determination upholds, in whole or part, the initial decision rejecting the petition for amendment, the determination shall also advise the individual submitting the appeal:

(i) Of his or her right to file a concise statement of the reasons for disagreeing with the decision of the Presidio Trust;

(ii) Of the procedure established by §1008.24 for the filing of the statement of disagreement;

(iii) That the statement which is filed will be made available to anyone to whom the record is subsequently disclosed together with, at the discretion of the Presidio Trust, a brief statement by the Presidio Trust summarizing its reasons for refusing to amend the record;

(iv) That prior recipients of the challenged record will be provided a copy of any statement of dispute to the extent that an accounting of disclosure was maintained; and

(v) Of his or her right to seek judicial review of the Presidio Trust's refusal to amend the record.

(3) If the determination reverses, in whole or in part, the initial decision rejecting the petition for amendment, the system manager responsible for the system containing the challenged record shall be directed to:

(i) Amend the challenged record accordingly; and

(ii) If an accounting of disclosures has been made, advise all previous recipients of the record of the amendment and its substance.

**§ 1008.24 Statements of disagreement.**

(a) *Filing of statement.* If the determination of the Executive Director under §1008.23 rejects in whole or part, a petition for amendment, the individual submitting the petition may file with the Privacy Act Officer a concise written statement setting forth the reasons for disagreement with the determination of the Presidio Trust.

(b) *Disclosure of statements.* In any disclosure of a record containing information about which an individual has filed a statement of disagreement under this section which occurs after the filing of the statement, the disputed portion of the record will be clearly noted and the recipient shall be

**36 CFR Ch. X (7-1-03 Edition)**

provided copies of the statement of disagreement. If appropriate, a concise statement of the reasons of the Presidio Trust for not making the requested amendments may also be provided to the recipient.

(c) *Maintenance of statements.* System managers shall develop procedures to assure that statements of disagreement filed with them shall be maintained in such a way as to assure dissemination of the statements to recipients of the records to which the statements pertain.

**PART 1009—ADMINISTRATIVE CLAIMS UNDER THE FEDERAL TORT CLAIMS ACT**

Sec.

1009.1 Purpose.

1009.2 Procedure for filing claims.

1009.3 Denial of claims.

1009.4 Payment of claims.

1009.5 Indemnification of Presidio Trust directors and employees.

AUTHORITY: Pub. L. 104-333, 110 Stat. 4097 (16 U.S.C. 460bb note); 28 U.S.C. 2672.

SOURCE: 63 FR 71784, Dec. 30, 1998, unless otherwise noted.

**§ 1009.1 Purpose.**

The purpose of this part is to establish procedures for the filing and settlement of claims under the Federal Tort Claims Act (in part, 28 U.S.C. secs. 2401(b), 2671-2680, as amended by Pub. L. 89-506, 80 Stat. 306). The officers to whom authority is delegated to settle tort claims shall follow and be guided by the regulations issued by the Attorney General prescribing standards and procedures for settlement of tort claims (28 CFR part 14).

**§ 1009.2 Procedure for filing claims.**

(a) The procedure for filing and the contents of claims shall be pursuant to 28 CFR 14.2, 14.3 and 14.4.

(b) Claims shall be filed directly with the Presidio Trust.

(c) Upon receipt of a claim, the time and date of receipt shall be recorded. The claim shall be forwarded with the investigative file immediately to the General Counsel for determination.

## Presidio Trust

Pt. 1010

### § 1009.3 Denial of claims.

Denial of a claim shall be communicated as provided by 28 CFR 14.9.

### § 1009.4 Payment of claims.

(a) When an award of \$2,500 or less is made, the voucher signed by the claimant shall be transmitted for payment to the Presidio Trust. When an award over \$2,500 is made, transmittal for payment will be made as prescribed by 28 CFR 14.10.

(b) Prior to payment, appropriate releases shall be obtained as provided in 28 CFR 14.10.

### § 1009.5 Indemnification of Presidio Trust directors and employees.

(a) The Presidio Trust may indemnify a Presidio Trust director or employee who is personally named as a defendant in any civil suit in state or federal court or an arbitration proceeding or other proceeding seeking damages against a Presidio Trust director or employee personally, for any verdict, judgment, or other monetary award which is rendered against such director or employee, provided that the conduct giving rise to the verdict, judgment, or award was taken within the scope of his or her duties or employment and that such indemnification is in the interest of the Presidio Trust as determined by

(1) the Board, with respect to claims against an employee; or

(2) a majority of the Board, exclusive of the director against whom claims have been made, with respect to claims against a director.

(b) The Presidio Trust may settle or compromise a personal damage claim against a Presidio Trust director or employee by the payment of available funds, at any time, provided the alleged conduct giving rise to the personal damage claim was taken within the scope of the duties or employment of the director or employee and that such settlement or compromise is in the interest of the Presidio Trust as determined by:

(1) the Board, with respect to claims against an employee; or

(2) a majority of the Board, exclusive of the director against whom claims have been made, with respect to claims against a director.

(c) The Presidio Trust will not entertain a request either to agree to indemnify or to settle a personal damage claim before entry of an adverse verdict, judgment, or award, unless exceptional circumstances exist as determined by:

(1) the Board, with respect to claims against an employee; or

(2) a majority of the Board, exclusive of the director against whom claims have been made, with respect to claims against a director.

(d) A Presidio Trust director or employee may request indemnification to satisfy a verdict, judgment, or award entered against the director or employee. The director or employee shall submit a written request, with appropriate documentation including copies of the verdict, judgment, award, or settlement proposal, in a timely manner to the General Counsel, who shall make a recommended disposition of the request. Where appropriate, the Presidio Trust shall seek the views of the Department of Justice. The General Counsel shall forward the request, the accompanying documentation, and the General Counsel's recommendation to the Board for decision. In the event that a claim is made against the General Counsel, the Chair shall designate a director or employee of the Trust to fulfill the duties otherwise assigned to the General Counsel under this section.

(e) Any payment under this section either to indemnify a Presidio Trust director or employee or to settle a personal damage claim shall be contingent upon the availability of funds.

## PART 1010—ENVIRONMENTAL QUALITY

Sec.

1010.1 Policy.

1010.2 Purpose.

1010.3 Definitions.

1010.4 NEPA Compliance Coordinator.

1010.5 Major decision points.

1010.6 Determination of requirement for EA or EIS.

1010.7 Actions that do not require an EA or EIS.

1010.8 Actions that normally require an EIS.

1010.9 Preparation of an EIS.

1010.10 Actions that normally require an EA.

1010.11 Preparation of an EA.

## § 1010.1

- 1010.12 Public involvement.
- 1010.13 Trust decision-making procedures.
- 1010.14 Review of proposals by project applicants.
- 1010.15 Actions where lead agency designation is necessary.
- 1010.16 Actions to encourage agency cooperation early in the NEPA process.
- 1010.17 Actions to eliminate duplication with State and local procedures.

AUTHORITY: Pub. L. 104-333, 110 Stat. 4097 (16 U.S.C. sec. 460bb note); 42 U.S.C. sec. 4321 *et seq.*; 40 CFR 1507.3.

SOURCE: 65 FR 55905, Sept. 15, 2000, unless otherwise noted.

### § 1010.1 Policy.

The Presidio Trust's policy is to:

- (a) Use all practical means, consistent with the Trust's statutory authority, available resources, and national policy, to protect and enhance the quality of the human environment;
- (b) Ensure that environmental factors and concerns are given appropriate consideration in decisions and actions by the Trust;
- (c) Use systematic and timely approaches which will ensure the integrated use of the natural and social sciences and environmental design arts in planning and decision-making which may have an impact on the human environment;
- (d) Develop and utilize ecological, cultural, and other environmental information in the management of the Presidio Trust Area and its natural, historic, scenic, cultural, and recreational resources pursuant to the Trust Act;
- (e) Invite the cooperation and encourage the participation, where appropriate, of Federal, State, and local authorities and the public in Trust planning and decision-making processes that affect the quality of the human environment; and
- (f) Minimize any possible adverse effects of Trust decisions and actions upon the quality of the human environment.

### § 1010.2 Purpose.

The regulations in this part incorporate and supplement the Council on Environmental Quality's (CEQ) regulations at 40 CFR parts 1500 through 1508 for implementing the procedural provisions of the National Environmental

## 36 CFR Ch. X (7-1-03 Edition)

Policy Act of 1969, as amended (NEPA), and otherwise to describe how the Trust intends to consider environmental factors and concerns in the Trust's decision-making process within the requirements set forth in NEPA and CEQ regulations.

### § 1010.3 Definitions.

(a) The following terms have the following meanings as used in this part:

*Decision-maker* means the Board or its designee.

*EA* means an environmental assessment, as defined at 40 CFR 1508.9.

*EIS* means an environmental impact statement, as defined at 40 CFR 1508.11.

*Project applicant* means an individual, firm, partnership, corporation, joint venture, or other public or private entity other than the Trust (including a combination of more than one such entities) which seeks to demolish, construct, reconstruct, develop, preserve, rehabilitate, or restore real property within the Presidio Trust Area.

(b) If not defined in this part or in this chapter, other terms used in this part have the same meanings as those provided in 40 CFR part 1508.

### § 1010.4 NEPA Compliance Coordinator.

(a) The NEPA Compliance Coordinator, as designated by the Executive Director, shall be the Trust official responsible for implementation and operation of the Trust's policies and procedures on environmental quality and control. The delegation of this responsibility shall not abrogate the responsibility of the Executive Director and the Board to ensure that NEPA and other applicable laws are followed, or the right of the Executive Director and the Board to overrule or alter decisions of the NEPA Compliance Coordinator in accordance with the Trust's regulations and procedures.

(b) The NEPA Compliance Coordinator shall:

- (1) Coordinate the formulation and revision of Trust policies and procedures on matters pertaining to environmental protection and enhancement;

## Presidio Trust

## § 1010.6

(2) Establish and maintain working relationships with relevant government agencies concerned with environmental matters;

(3) Develop procedures within the Trust's planning and decision-making processes to ensure that environmental factors are properly considered in all proposals and decisions in accordance with this part;

(4) Develop, monitor, and review the Trust's implementation of standards, procedures, and working relationships for protection and enhancement of environmental quality and compliance with applicable laws and regulations;

(5) Monitor processes to ensure that the Trust's procedures regarding consideration of environmental quality are achieving their intended purposes;

(6) Advise the Board, officers, and employees of the Trust of technical and management requirements of environmental analysis, of appropriate expertise available, and, in consultation with the Trust's General Counsel, of relevant legal developments;

(7) Monitor the consideration and documentation of the environmental aspects of the Trust's planning and decision-making processes by appropriate officers and employees of the Trust;

(8) Ensure that all EA's and EIS's are prepared in accordance with the appropriate regulations adopted by the CEQ and the Trust;

(9) Consolidate and transmit to appropriate parties the Trust's comments on EIS's and other environmental reports prepared by other agencies;

(10) Acquire information and prepare appropriate reports on environmental matters required of the Trust;

(11) Coordinate Trust efforts to make available to other parties information and advice on the Trust's policies for protecting and enhancing the quality of the environment; and

(12) Designate other Trust employees to execute these duties under the supervision of the NEPA Compliance Coordinator, where necessary for administrative convenience and efficiency. As used in this chapter, the term "NEPA Compliance Coordinator" includes any such designee.

### § 1010.5 Major decision points.

(a) The possible environmental effects of a proposed action or project within the Presidio Trust Area must be considered along with technical, financial, and other factors throughout the decision-making process. Most Trust projects have three distinct stages in the decision-making process:

(1) Conceptual or preliminary study stage;

(2) Detailed planning or final decision stage;

(3) Implementation stage.

(b) Environmental review will be integrated into the decision-making process of the Trust as follows:

(1) During the conceptual or preliminary study stage, the NEPA Compliance Coordinator shall determine whether the proposed action or project is one which is categorically excluded under § 1010.7, has been adequately reviewed in a previously prepared EA and/or EIS, or requires further NEPA review (*i.e.*, an EA or an EIS).

(2) If the proposed action or project is not categorically excluded and has not been adequately reviewed in a previously prepared EA and/or EIS, then prior to the Trust's proceeding beyond the conceptual or preliminary study stage, the NEPA Compliance Coordinator must determine whether an EIS is required. When appropriate, prior to the determination as to whether an EIS is required, the NEPA Compliance Coordinator may initiate a public scoping process in order to inform such a determination.

(3) If an EIS is determined to be necessary, the Trust shall initiate a public scoping process in accordance with 40 CFR 1501.7. An EIS, if determined necessary, must be completed and circulated at the earliest point at which meaningful analysis can be developed for the proposed action or project and prior to the Trust's final approval of the proposed action or project.

### § 1010.6 Determination of requirement for EA or EIS.

In deciding whether to require the preparation of an EA or an EIS, the NEPA Compliance Coordinator will determine whether the proposal is one that:

## § 1010.7

## 36 CFR Ch. X (7-1-03 Edition)

- (a) Normally does not require either an EA or an EIS;
- (b) Normally requires an EIS; or
- (c) Normally requires an EA, but not necessarily an EIS.

### § 1010.7 Actions that do not require an EA or EIS.

(a) *Categorical Exclusions.* Pursuant to 40 CFR 1508.4, the Trust has determined that the categories of action identified in this paragraph have no significant effect, either individually or cumulatively, on the human environment and are therefore categorically excluded. Such actions (whether approved by the Trust or undertaken by the Trust directly or indirectly) do not require the preparation of an EA or an EIS:

- (1) Personnel actions and investigations and personal services contracts;
- (2) Administrative actions and operations directly related to the operation of the Trust (e.g., purchase of furnishings, services, and equipment) provided such actions and operations are consistent with applicable Executive Orders;
- (3) Internal organizational changes and facility and office expansions, reductions, and closings;
- (4) Routine financial transactions, including such things as salaries and expenses, procurement, guarantees, financial assistance, income transfers, audits, fees, bonds and royalties;
- (5) Management, formulation, allocation, transfer and reprogramming of the Trust's budget;
- (6) Routine and continuing government business, including such things as supervision, administration, operations, maintenance, and replacement activities having limited context and intensity (limited size and magnitude or short-term effects);
- (7) Preparation, issuance, and submittal of publications and routine reports;
- (8) Activities which are educational, informational, or advisory (including interpretive programs), or otherwise in consultation with or providing technical assistance to other agencies, public and private entities, visitors, individuals, or the general public;
- (9) Legislative proposals of an administrative or technical nature, including such things as changes in authoriza-

tions for appropriations or financing authority, minor boundary changes and land transactions; or having primarily economic, social, individual or institutional effects, as well as comments and reports on legislative proposals;

(10) Proposal, adoption, revision, and termination of policies, directives, regulations, and guidelines:

(i) That are of an administrative, financial, legal, technical, or procedural nature, the environmental effects of which are too broad, speculative, or conjectural to lend themselves to environmental analysis and the implementation of which will be subject to the NEPA process either collectively or on a case-by-case basis; or

(ii) Where such actions will not potentially:

(A) Increase public use to the extent of compromising the nature and character of the area or of causing significant physical damage to it;

(B) Introduce non-compatible uses that might compromise the nature and characteristics of the area or cause significant physical damage to it;

(C) Conflict with adjacent ownerships or land uses; or

(D) Cause a significant nuisance to adjacent owners or occupants;

(11) Preparation, approval, coordination, and implementation of plans, including priorities, justifications, and strategies, for research, monitoring, inventorying, and information gathering that is not or is only minimally manipulative and causes no or only minimal physical damage;

(12) Identification, nomination, certification, and determination of eligibility of properties for listing in the National Register of Historic Places and the National Historic Landmark and National Natural Landmark Programs;

(13) Minor or temporary changes in amounts or types of visitor use for the purpose of ensuring visitor safety or resource protection, minor changes in programs or regulations pertaining to visitor activities, and approval of permits or other use and occupancy agreements for special events or public assemblies and meetings, provided such events, assemblies, and meetings entail

## Presidio Trust

## § 1010.7

only short-term or readily mitigated environmental impacts;

(14) Designation of environmental study areas and research areas, including those closed temporarily or permanently to the public, provided such designation would cause no or only minimal environmental impact;

(15) Land and boundary surveys and minor boundary adjustments or transfers of administrative jurisdiction resulting in no significant change in land use;

(16) Archaeological surveys and permits involving only surface collection or small-scale test excavations;

(17) Changes or amendments to an approved plan or action when such changes or amendments would cause no or only minimal environmental impact;

(18) Contracts, work authorizations, or procurement actions related to proposals, programs, and master agreements related to administrative operation of the Trust;

(19) The leasing, permitting, sale, or financing of, or granting of non-fee interests regarding, real or personal property in the Presidio Trust Area, provided that such actions would have no or only minimal environmental impact;

(20) Extension, reissuance, renewal, minor modification, or conversion in form of agreements for use of real property (including but not limited to leases, permits, licenses, concession contracts, use and occupancy agreements, easements, and rights-of-way), so long as such agreements were previously subject to NEPA and do not involve new construction or new or substantially greater environmental impacts, and so long as no new information is known or no changed circumstances have occurred that would give rise to new or substantially greater environmental impacts.

(21) Rehabilitation, modification, or improvement of historic properties that have been determined to be in conformance with the Secretary of the Interior's "Standards for the Treatment of Historic Properties" at 36 CFR part 68 and that would have no or only minimal environmental impact;

(22) Rehabilitation, maintenance, modification or improvement of non-

historic properties that is consistent with applicable Executive Orders, provided there is no potential for significant environmental impacts, including impacts to cultural landscapes or archaeological resources;

(23) Removal, reduction, or restraint of resident individuals of species that are not threatened or endangered which pose dangers to visitors, residents, or neighbors or immediate threats to resources of the Presidio Trust Area;

(24) Removal of non-historic materials and structures in order to restore natural conditions when such removal has no potential for significant environmental impacts, including impacts to cultural landscapes or archaeological resources and is consistent with applicable Executive Orders;

(25) Installation of signs, displays, and kiosks, etc.;

(26) Replacement of minor structures and facilities (e.g., signs, kiosks, fences, comfort stations, and parking lots) with little or no change in location, capacity, or appearance;

(27) Repair, resurfacing, striping, installation of traffic control devices, and repair/replacement of guardrails, culverts, signs, and other minor features, on existing roads and parking facilities, provided there is no potential for significant environmental impact;

(28) Minor trail relocation, development of compatible trail networks on roads or other formally established routes, and trail maintenance and repair;

(29) Construction or rehabilitation in previously disturbed or developed areas required to meet health or safety regulations, or to meet requirements for making facilities accessible to the handicapped provided such construction or rehabilitation is implemented in a manner consistent with applicable Executive Orders;

(30) Landscaping and landscape maintenance in previously disturbed or developed areas;

(31) Minor changes in programs and regulations pertaining to visitor activities;

(32) Routine maintenance, property management, and resource management, with no potential for significant environmental impact and that are

## § 1010.8

## 36 CFR Ch. X (7-1-03 Edition)

consistent with the Secretary of the Interior's "Standards for the Treatment of Historic Properties" at 36 CFR part 68, as applicable, and with applicable Executive Orders;

(33) Upgrading or adding new utility facilities to existing poles, or replacement poles which do not change existing pole line configurations.

(34) Issuance of rights-of-way for overhead utility lines to an individual building or well from an existing line where installation will not result in significant visual intrusion or non-conformance with the Secretary's "Standards for the Treatment of Historic Properties" at 36 CFR part 68, as applicable, and will involve no clearance of vegetation other than for placement of poles;

(35) Issuance of rights-of-way for minor overhead utility lines not involving placement of poles or towers and not involving vegetation management or significant visual intrusion in an area administered by NPS or the Trust or non-conformance with the Secretary's "Standards for the Treatment of Historic Properties" at 36 CFR part 68, as applicable;

(36) Installation of underground utilities in previously disturbed areas having stable soils, or in an existing utility right-of-way; and

(37) Experimental testing of no longer than 180 days of mass transit systems, and changes in operation of existing systems with no potential for significant environmental impact.

(b) *Extraordinary circumstances.* An action that falls into one or more of the categories in paragraph (a) of this section may still require the preparation of an EIS or an EA if the NEPA Compliance Coordinator determines that it meets the criteria stated in § 1010.8(b) or § 1010.10(b), respectively, or involves extraordinary circumstances that may have a significant environmental effect. At its discretion, the Trust may require the preparation of an EA or an EIS for a proposal or action that otherwise qualifies for a categorical exclusion. Criteria used in determining whether to prepare an EA or EIS for an action that otherwise qualifies for a categorical exclusion include whether an action may:

(1) Have significant adverse effects on public health or safety;

(2) Have significant adverse effects on such unique geographic characteristics as historic or cultural resources, park, recreation or refuge lands, sole or principal drinking water aquifers, wetlands, floodplains, or ecologically significant or critical areas;

(3) Have highly controversial environmental effects;

(4) Have highly uncertain and potentially significant environmental effects or involve unique or unknown environmental risks;

(5) Establish a precedent for future action or represent a decision in principle about future actions with potentially significant environmental effects;

(6) Be directly related to other actions with individually insignificant but cumulatively significant environmental effects;

(7) Have significant adverse effects on properties listed or eligible for listing on the National Register of Historic Places;

(8) Have significant adverse effects on species listed or proposed to be listed on the List of Endangered or Threatened Species, or have adverse effects on designated Critical Habitat for these species;

(9) Require compliance with Executive Order 11988 (Floodplain Management), Executive Order 11990 (Protection of Wetlands), Executive Order 13007 (Indian Sacred Sites), or the Fish and Wildlife Coordination Act; and/or

(10) Threaten to violate a Federal, State, local or tribal law or requirement imposed for the protection of the environment.

### § 1010.8 Actions that normally require an EIS.

(a) *General procedure.* So long as a proposed action or project is not categorically excluded under § 1010.7, the Trust shall require the preparation of an EA to determine if the proposed action or project requires an EIS. Nevertheless, if it is readily apparent to the NEPA Compliance Coordinator that the proposed action or project will have a significant impact on the environment, an EA is not required, and the Trust will prepare or direct the



## Presidio Trust

## § 1010.10

preparation of an EIS without preparing or completing the preparation of an EA. To assist the NEPA Compliance Coordinator in determining if a proposal or action normally requires the preparation of an EIS, the following criteria and categories of action are provided.

(b) *Criteria.* Criteria used to determine whether proposals or actions may significantly affect the environment and therefore require an EIS are described in 40 CFR 1508.27.

(c) *Categories of action.* The following categories of action normally require an EIS:

(1) Legislative proposals made by the Trust to the United States Congress, other than those described in § 1010.7(b)(9);

(2) Approval, funding, construction, and/or demolition in preparation for construction of any new building, if that activity has a significant effect on the human environment;

(3) Proposals that would significantly alter the kind and amount of natural, recreational, historical, scenic, or cultural resources of the Presidio Trust Area or the integrity of the setting; and

(4) Approval or amendment of a general land use or resource management plan for the entire Presidio Trust Area.

### § 1010.9 Preparation of an EIS.

(a) *Notice of intent.* When the Trust decides to prepare an EIS, it shall publish a notice of intent in the FEDERAL REGISTER in accordance with 40 CFR 1501.7 and 1508.22. Where there is a lengthy period between the Trust's decision to prepare an EIS and the time of actual preparation, then at the discretion of the NEPA Compliance Coordinator the notice of intent shall be published at a reasonable time in advance of preparation of the EIS.

(b) *Preparation.* After having determined that an EIS will be prepared and having published the notice of intent, the Trust will begin to prepare or to direct the preparation of the EIS. The EIS shall be formatted in accordance with 40 CFR 1502.10.

(c) *Supplemental environmental impact statements.* The Trust may supplement a draft or final EIS at any time. The

Trust shall prepare a supplement to either a draft or final EIS when:

(1) Substantial changes are proposed to an action analyzed in the draft or final EIS that are relevant to environmental concerns;

(2) There are significant new circumstances or information relevant to environmental concerns and bearing on the proposed action or its impacts; or

(3) Actions are proposed which relate to or are similar to other actions taken or proposed and that together will have a cumulatively significant impact on the human environment.

### § 1010.10 Actions that normally require an EA.

(a) *General procedure.* If a proposal or action is not one that normally requires an EIS, and does not qualify for a categorical exclusion under § 1010.7, the Trust will require, prepare, or direct the preparation of an EA. An EA should be prepared when the Trust has insufficient information on which to determine whether a proposal may have significant impacts. An EA assists the Trust in complying with NEPA when no EIS is necessary, and it facilitates the preparation of an EIS, if one is necessary.

(b) *Criteria.* Criteria used to determine those categories of action that normally require an EA, but not necessarily an EIS, include:

(1) Potential for degradation of environmental quality;

(2) Potential for cumulative adverse impact on environmental quality; and

(3) Potential for adverse impact on protected resources (e.g., natural, scenic, recreational, historical, and cultural resources).

(c) *Categories of action.* The following categories of action normally require the preparation of an EA:

(1) Promulgation of regulations and requirements that are not categorically excluded;

(2) Proposals submitted by project applicants to the Trust for its review, as described in § 1010.14;

(3) Proposals to add or alter access between the Presidio Trust Area and surrounding neighborhoods; and

(4) Contracts, work authorizations, and master agreements related to and implementing programs, policies, and

## § 1010.11

proposals which are not categorically excluded and for which there is no previously prepared EA and/or EIS.

### § 1010.11 Preparation of an EA.

(a) *When to prepare.* The Trust will begin the preparation of an EA (or require it to be begun) as early as possible after it is determined by the NEPA Compliance Coordinator to be required. The Trust will provide notice of such determinations in accordance with § 1010.12. The Trust may prepare or require an EA at any time to assist planning and decision-making.

(b) *Content and format.* An EA is a concise public document used to determine whether to prepare an EIS. An EA should address impacts, including cumulative impacts, on those resources that are specifically relevant to the particular proposal. Those impacts should be addressed in as much detail as is necessary to allow an analysis of the alternatives and the proposal. The EA shall contain brief discussions of the following topics:

- (1) Purpose and need for the proposed action.
- (2) Description of the proposed action.
- (3) Alternatives considered, including a No Action alternative.
- (4) Environmental effects of the proposed action and the alternatives, including mitigation measures.
- (5) Listing of agencies, organizations, and/or persons consulted.

(c) *Finding of no significant impact (FONSI).* If an EA is completed and the NEPA Compliance Coordinator determines that an EIS is not required, then the NEPA Compliance Coordinator shall prepare a finding of no significant impact. The finding of no significant impact shall be made available to the public by the Trust as specified in 40 CFR 1506.6.

(d) *Mitigated FONSI.* If an EA is completed and the NEPA Compliance Coordinator determines that an EIS is required, then prior to preparation of an EIS, the proposal may be revised in order to mitigate the impacts identified in the EA through adherence to legal requirements, inclusion of mitigation as an integral part of the proposal, and/or fundamental changes to the proposal. A supplemental EA will

## 36 CFR Ch. X (7-1-03 Edition)

be prepared on the revised proposal and will result in a Mitigated Finding of No Significant Impact, preparation of an EIS, or additional revision of the proposal and a supplemental EA.

### § 1010.12 Public involvement.

The Trust will make public involvement an essential part of its environmental review process. Public notice of anticipated Trust actions that may have a significant environmental impact, opportunities for involvement, and availability of environmental documents will be provided through announcements in the Trust's monthly newsletter, postings on its web site ([www.presidiotrust.gov](http://www.presidiotrust.gov)), placement of public notices in newspapers, direct mailings, and other means appropriate for involving the public in a meaningful way. The Trust will conduct scoping with interested federal, state and local agencies and Indian tribes, will solicit and accept written scoping comments and will hold public scoping meetings to gather early input whenever it determines an EIS to be necessary and otherwise as appropriate. Notice of all public scoping meetings will be given in a timely manner. Interested persons may also obtain information concerning any pending EIS or any other element of the environmental review process of the Trust by contacting the NEPA Compliance Coordinator at the following address: Presidio Trust, P.O. Box 29052, San Francisco, California 94129-0052.

### § 1010.13 Trust decision-making procedures.

To ensure that at major decision-making points all relevant environmental concerns are considered by the decision-maker, the following procedures are established.

(a) An environmental document (*i.e.*, the EA, finding of no significant impact, EIS, or notice of intent), in addition to being prepared at the earliest point in the decision-making process, shall accompany the relevant proposal or action through the Trust's decision-making process to ensure adequate consideration of environmental factors.

## Presidio Trust

## § 1010.15

(b) The Trust shall consider in its decision-making process only decision alternatives encompassed by the range of alternatives discussed in the relevant environmental documents. Also, where an EIS has been prepared, the Trust shall consider all alternatives described in the EIS, a written record of the consideration of alternatives during the decision-making process shall be maintained, and a monitoring and enforcement program shall be adopted and summarized where applicable for any mitigation.

(c) Any environmental document prepared for a proposal or action shall be made part of the record of any formal rulemaking by the Trust.

### § 1010.14 Review of proposals by project applicants.

(a) An EA shall be required for each proposal for demolition, construction, reconstruction, development, preservation, rehabilitation, or restoration of real property submitted by a project applicant to the Trust for its review, and which the decision-maker agrees to consider, unless categorically excluded or covered by a previously prepared EA and/or EIS.

(b) The decision-maker may not take any approval action on such a proposal submitted by a project applicant until such time as the appropriate environmental review documents have been prepared and submitted to the decision-maker.

(c) At a minimum, and as part of any submission made by a project applicant to the decision-maker for its approval, such project applicant shall make available data and materials concerning the proposal sufficient to permit the Trust to carry out its environmental review responsibilities. When requested, the project applicant shall provide additional information that the NEPA Compliance Coordinator believes is necessary to permit it to satisfy its environmental review functions.

(d) With respect to each project proposed for consideration for which the NEPA Compliance Coordinator determines that an EA shall be prepared, the decision-maker may require a project applicant to submit a draft EA regarding its proposal for the Trust's

evaluation and revision. In accordance with 40 CFR 1506.5(b), the Trust shall make its own evaluation of the environmental issues and shall take responsibility for the scope and content of the final EA.

(e) With respect to each project proposed for consideration for which the NEPA Compliance Coordinator determines an EIS shall be prepared, the decision-maker may require a project applicant to pay a non-refundable fee to the Trust sufficient to cover a portion or all of the Trust's anticipated costs associated with preparation and review of the EIS, including costs associated with review under other applicable laws. Such fee shall be paid to the Trust in full prior to commencement of the preparation of the EIS or any amendment or supplement thereto.

(f) In accordance with 40 CFR 1506.5(c), the EIS shall be prepared by the Trust and/or by contractors who are selected by the Trust and who certify that they have no financial or other interest in the outcome of the project, and the Trust shall independently evaluate the EIS prior to its approval and take responsibility for ensuring its adequacy. The EIS shall be prepared in accordance with 40 CFR part 1502.

(g) The NEPA Compliance Coordinator may set time limits for environmental review appropriate to each proposal, consistent with 40 CFR 1501.8 and 1506.10.

(h) The NEPA Compliance Coordinator shall at the earliest possible time ensure that the Trust commences its environmental review on a proposed project and shall provide the project applicant with any policies or information deemed appropriate in order to permit effective and timely review by the Trust of a proposal once it is submitted to the decision-maker for approval.

### § 1010.15 Actions where lead agency designation is necessary.

(a) Consistent with 40 CFR 1501.5, where a proposed action by the Trust involves one or more other Federal agencies, or where actions by the Trust and one or more Federal agencies are directly related to each other because of their functional interdependence or

**§ 1010.16**

**36 CFR Ch. X (7-1-03 Edition)**

geographical proximity, the Trust will seek designation as lead agency for those actions that relate solely to the Presidio Trust Area.

(b) For an action that qualifies as one for which the Trust will seek designation as lead agency, the Trust will promptly consult with the appropriate Federal agencies to establish lead agency, joint lead agency, and/or cooperating agency designations.

(c) For an action as to which the Trust undertakes lead, joint lead, or cooperating agency status, the Trust is authorized to enter into a memorandum of understanding or agreement to define the rights and responsibilities of the relevant agencies.

**§ 1010.16 Actions to encourage agency cooperation early in the NEPA process.**

Consistent with 40 CFR 1501.6, the Trust may request the NPS to be a cooperating agency for actions or projects significantly affecting the quality of the Presidio. In addition, upon request of the Trust, any other Federal, State, local, or tribal agency that has jurisdiction by law or special

expertise with respect to any environmental issue that should be addressed in the analysis may be a cooperating agency. The Trust shall use the environmental analysis and proposals of cooperating agencies with jurisdiction by law or special expertise to the maximum extent possible consistent with its responsibility as lead or joint lead agency.

**§ 1010.17 Actions to eliminate duplication with State and local procedures.**

Consistent with 40 CFR 1506.2, the Trust shall cooperate with State and local agencies to the fullest extent possible to reduce duplication between NEPA and State and local requirements. Such cooperation shall to the fullest extent possible include:

- (a) Joint planning processes;
- (b) Joint environmental research and studies;
- (c) Joint public hearings (except where otherwise provided by statute); and
- (d) Joint environmental assessments and/or Environmental Impact Statements/Environmental Impact Reports.

## CHAPTER XI—ARCHITECTURAL AND TRANSPORTATION BARRIERS COMPLIANCE BOARD

---

<i>Part</i>		<i>Page</i>
1120	Public availability of information .....	273
1121	Privacy Act implementation .....	287
1150	Practice and procedures for compliance hearings. ..	289
1151	Bylaws .....	302
1154	Enforcement of nondiscrimination on the basis of handicap in programs or activities conducted by the Architectural and Transportation Barriers Compliance Board .....	306
1190	Minimum guidelines and requirements for acces- sible design .....	311
1191	Americans with Disabilities Act (ADA) accessi- bility guidelines for buildings and facilities .....	325
1192	Americans with Disabilities Act (ADA) accessi- bility guidelines for transportation vehicles .....	472
1193	Telecommunications Act accessibility guidelines ..	511
1194	Electronic and information technology accessi- bility standards .....	530
1195–1199	[Reserved]	



## PART 1120—PUBLIC AVAILABILITY OF INFORMATION

### Subpart A—General

Sec.

- 1120.1 Purpose and scope of this part.
- 1120.2 Definitions.
- 1120.3 Existing records.

### Subpart B—Published Information

- 1120.5 Information published in the FEDERAL REGISTER.
- 1120.6 Information in A&TBCB publications.

### Subpart C—Records Available for Public Inspection and Copying, Documents Published and Indexed

- 1120.11 Records available for inspection.
- 1120.12 Indexes to certain records.
- 1120.13 Effect of nonavailability.

### Subpart D—Information Available Upon Request

- 1120.21 Policy on disclosure of records.
- 1120.22 Requests to which this subpart applies.
- 1120.23 Where requests for agency records must be filed.
- 1120.24 Misdirected written requests; oral requests.
- 1120.25 Form of requests.
- 1120.26 Deficient descriptions.
- 1120.31 A&TBCB receipt of requests; responsibilities of Freedom of Information Officer.
- 1120.32 A&TBCB action on requests.
- 1120.33 Time allowed for initial action on requests.
- 1120.34 Initial denials of requests.
- 1120.36 Appeals from initial denials.
- 1120.37 A&TBCB action on appeals.
- 1120.38 Time allowed for action on appeals.
- 1120.41 Exempt documents.
- 1120.42 Release of exempt documents.

### Subpart E—Copies of Records and Fees for Services

- 1120.51 Charges for services, generally.
- 1120.52 Computerized records.
- 1120.53 Payment of fees.

AUTHORITY: 5 U.S.C. 552, the Freedom of Information Act, as amended.

SOURCE: 45 FR 80976, Dec. 8, 1980, unless otherwise noted.

### Subpart A—General

#### § 1120.1 Purpose and scope of this part.

This part contains the general rules of the Architectural and Transportation Barriers Compliance Board for public access to Board records. These regulations implement 5 U.S.C. 552, the Freedom of Information Act, as amended, and the policy of the Board. It is the Board's policy to disseminate information on matters of interest to the public and to disclose on request all information contained in records in its custody insofar as is compatible with the discharge of its responsibilities and consistent with the law. This part sets forth generally the categories of records accessible to the public, the types of records subject to prohibitions or restrictions on disclosure, and the places and procedures to obtain information from records in the custody of the A&TBCB.

#### § 1120.2 Definitions.

For the purposes of this part:

(a) *A&TBCB* or *Board* means the Architectural and Transportation Barriers Compliance Board.

(b) *A&TBCB record* or *record* means any document, writing, photograph, sound or magnetic recording, drawing or other similar thing by which information has been preserved, from which the information can be retrieved and copied, and which is, was, or is alleged to be under the control of the A&TBCB.

(1) The term includes—

(i) Informal writings such as handwritten notes and drafts;

(ii) Information preserved in a form which must be translated or deciphered by machine in order to be intelligible to humans;

(iii) Records which were created or acquired by the A&TBCB, its members, its employees, its members' employees, or persons acting on behalf of its members, by use of A&TBCB funds or in the course of transacting official business for the A&TBCB.

(2) The term does not include—

(i) Materials which are legally owned by an A&TBCB member, employee, or

member's employee or representative in his or her purely personal capacity; and

(ii) Materials published by non-Federal organizations which are readily available to the public, such as books, journals, standards, and periodicals available through reference libraries, even if such materials are in the A&TBCB's possession.

(c) The terms *agency*, *person*, *party*, *rule*, *rulemaking*, *order*, and *adjudication* have the meanings given in 5 U.S.C. 551, except where the context demonstrates that a different meaning is intended, and except that for purposes of the Freedom of Information Act the term *agency* as defined in 5 U.S.C. 551 includes any executive department, military department, Government corporation, Government controlled corporation, the United States Postal Service, or other establishment in the executive branch of the Government (including the Executive Office of the President) or any independent regulatory agency.

(d) A government record *under the control of the A&TBCB* means that the record is subject to the free disposition of the A&TBCB. This includes keeping the record available for governmental use as required and protecting, preserving, and exercising such control over it as may be necessary for that purpose. Control of a record is not synonymous with, and does not require, actual physical possession of the record.

(e) *Request* means a request to inspect or obtain a copy of one or more records.

(f) *Requestor* means any person who submits a request to the A&TBCB.

(g) *Public member* means a member appointed by the President from among members of the general public.

(h) *Direct Costs* means those expenditures which an agency actually incurs in searching for and duplicating (and in the case of commercial requesters, reviewing) documents to respond to a FOIA request. Direct costs include, for example, the salary of the employee performing work (the basic rate of pay for the employee plus 16 percent of that rate to cover benefits) and the cost of operating duplicating machinery. Not included in direct costs are overhead

expenses such as costs of space, and heating or lighting the facility in which the records are stored.

(i) *Search* includes all time spent looking for material that is responsive to a request, including page-by-page or line-by-line identification of material within documents. Agencies should ensure that searching for material is done in the most efficient and least expensive manner so as to minimize costs for both the agency and the requester. For example, agencies should not engage in line-by-line search when merely duplicating an entire document would prove the less expensive and quicker method of complying with a request. *Search* should be distinguished, moreover, from *review* of material in order to determine whether the material is exempt from disclosure (see paragraph (k) of this section). Searches may be done manually or by computer using existing programming.

(j) *Duplication* refers to the process of making a copy of a document necessary to respond to an FOIA request. Such copies can take the form of paper copy, microform, audio-visual materials, or machine readable documentation (e.g., magnetic tape or disk), among others. The copy provided must be in a form that is reasonably usable by requesters.

(k) *Review* refers to the process of examining documents located in response to a request that is for a commercial use (see paragraph (l) of this section) to determine whether any portion of any document located is permitted to be withheld. It also includes processing any documents for disclosure, e.g., doing all that is necessary to excise them and otherwise prepare them for release. Review does not include time spent resolving general legal or policy issues regarding the application of exemptions.

(l) *Commercial Use Request* refers to a request from or on behalf of one who seeks information for a use or purpose that furthers the commercial, trade, or profit interests of the requester or the person on whose behalf the request is made. In determining whether a requester properly belongs in this category, agencies must determine the use to which a requester will put the documents requested. Moreover, where an



agency has reasonable cause to doubt the use to which a requester will put the records sought, or where that use is not clear from the request itself, agencies should seek additional clarification before assigning the request to a specific category.

(m) *Educational Institution* refers to a preschool, a public or private elementary or secondary school, an institution of graduate higher education, an institution of undergraduate higher education, an institution of professional education, and an institution of vocational education, which operates a program or programs of scholarly research.

(n) *Non-Commercial Scientific Institution* refers to an institution that is not operated on a *commercial* basis as that term is referenced in paragraph (l) of this section, and which is operated solely for the purpose of conducting scientific research the results of which are not intended to promote any particular product or industry.

(o) *Representative of the News Media* refers to any person actively gathering news for an entity that is organized and operated to publish or broadcast news to the public. The term *news* means information that is about current events or that would be of current interest to the public. Examples of news media entities include television or radio stations broadcasting to the public at large, and publishers of periodicals (but only in those instances when they can qualify as disseminators of *news*) who make their products available for purchase or subscription by the general public. These examples are not intended to be all-inclusive.

Moreover, as traditional methods of news delivery evolve (e.g., electronic dissemination of newspapers through telecommunications services), such alternative media would be included in this category. In the case of *freelance* journalists, they may be regarded as working for a news organization if they can demonstrate a solid basis for expecting publication through that organization, even though not actually employed by it. A publication contract would be the clearest proof, but agencies may also look to the past publica-

tion record of a requester in making this determination.

[45 FR 80976, Dec. 8, 1980, as amended at 52 FR 43195, Nov. 10, 1987; 55 FR 2519, Jan. 25, 1990]

### § 1120.3 Existing records.

All existing A&TBCB records are subject to routine destruction according to standard record retention schedules.

## Subpart B—Published Information

### § 1120.5 Information published in the FEDERAL REGISTER.

(a) *General.* In accordance with the provisions of 5 U.S.C. 552(a)(1), basic information concerning the organization, operations, functions, substantive and procedural rules and regulations, officials, office locations, and allocation of responsibilities for functions and programs of the A&TBCB is published in the FEDERAL REGISTER for the guidance of the public. This information includes—

(1) Description of the A&TBCB's organization and the established places at which, the employees from whom, and the methods whereby the public may obtain information, make submissions or requests, or obtain decisions;

(2) Statements of the general course and method by which the A&TBCB's functions are channeled and determined, including the nature and requirements of all formal and informal procedures available;

(3) Rules of procedure, descriptions of forms available or the places at which forms may be obtained, and instructions as to the scope and contents of all papers, reports, or examinations;

(4) Substantive rules of general applicability adopted as authorized by law, and statements of general policy or interpretations of general applicability formulated and adopted by the A&TBCB, and

(5) Each amendment, revision, or repeal of the foregoing. Indexes to the FEDERAL REGISTER are published in each daily issue and compiled currently on a monthly, quarterly, and annual basis. Copies of the FEDERAL REGISTER and its indexes are available in many libraries and may be purchased from the Superintendent of Documents, Government Printing Office,

Washington, DC 20402. No formal request to examine documents in the FEDERAL REGISTER is necessary to inspect them at the place where they are kept. Materials incorporated by reference in the FEDERAL REGISTER are available for inspection in A&TBCB offices.

(b) *Code of Federal Regulations.* Title 36 of the *Code of Federal Regulations*, which is republished and updated annually, contains a compilation of documents published by the A&TBCB in the FEDERAL REGISTER which set forth substantive and procedural rules and regulations of the A&TBCB and statements of general policy or interpretations of general applicability formulated and adopted by the Board. Copies of the *Code of Federal Regulations* are available in many libraries and may be purchased from the Superintendent of Documents. Reference copies maintained in offices of the A&TBCB are available for examination without formal request.

(c) *Effect of nonpublication.* Except to the extent that a person has actual and timely notice of its terms, no person may in any manner be required to resort to, or be adversely affected by, any procedure or matter required to be published in the FEDERAL REGISTER, but not so published. For the purposes of this paragraph, material that is reasonably available to the class of persons affected by it is considered to be published in the FEDERAL REGISTER if it has been incorporated by reference in the FEDERAL REGISTER with the approval of the Director of the Federal Register.

**§ 1120.6 Information in A&TBCB publications.**

(a) *General.* Copies of information material shall be available upon oral or written request so long as an adequate supply exists. These informational materials include press releases, pamphlets, and other materials ordinarily made available to the public without cost as part of a public information program, and reprints of individual parts of the *Code of Federal Regulations* or FEDERAL REGISTER relating to programs affecting substantial segments of the general public. Copies of informational publications of the A&TBCB

which may be purchased from the Superintendent of Documents may be inspected in those offices of the A&TBCB in which reference copies are available. Compliance with the formal procedures provided in this part for obtaining access to A&TBCB records is not necessary for access to the materials described in this paragraph.

(b) *Published indexes.* The informational publications available from the A&TBCB may include indexes to materials published or contained in its records. They will include the current indexes required by the Freedom of Information Act to be maintained and made available for inspecting and copying, except as otherwise provided by published order, as noted below. These indexes provide identifying information for the public as to—

(1) Final opinions and orders made in the adjudication of cases;

(2) Statements of policy and interpretations adopted but not published in the FEDERAL REGISTER; and

(3) Administrative staff manuals and instructions to staff that affect a member of the public.

As promptly as possible after adoption of this part, these indexes will be made available to members of the public. Thereafter, updated indexes or supplements shall be published at least quarterly. However, the Board may determine by order published in the FEDERAL REGISTER that publication of an index is unnecessary and impracticable. In that case the Board shall provide copies of the index on request at a cost not to exceed the direct cost of duplication.

**Subpart C—Records Available for Public Inspection and Copying, Documents Published and Indexed**

**§ 1120.11 Records available for inspection.**

Except for those categories of materials listed in paragraph (a) of this section, paragraphs (a) (1) through (9) of § 1120.41 the following materials are available for public inspection and copying during normal business hours at the Washington office of the A&TBCB:

(a) Final opinions and orders made in the adjudication of cases;

(b) Statements of policy and interpretations which have been adopted under the authority of the A&TBCB and are not published in the FEDERAL REGISTER;

(c) Administrative staff manuals and instructions to staff that affect a member of the public;

(d) A record of the final votes of each member of the Board in every Board proceeding;

(e) Current indexes providing identifying information for the public as to the materials made available under paragraphs (a) through (d) of this section.

(f) All papers and documents made a part of the official record in administrative proceedings conducted by the A&TBCB in connection with the issuance, amendment, or revocation of rules and regulations or determinations having general applicability or legal effect with respect to members of the public or a class of the public.

(g) After a final order is issued in any adjudicative proceeding conducted by the A&TBCB, all papers and documents made a part of the official record of the proceeding. (The official docket is kept in the office of the administrative law judge hearing the case until a final order is issued.)

**§ 1120.12 Indexes to certain records.**

Current indexes are normally available to the public in published form as provided in § 1120.11. These indexes, whether or not published, are made available for inspection and copying on request. If published copies of a particular index are at any time not available or if publication of the index has been determined to be unnecessary and impracticable by order published in the FEDERAL REGISTER, copies of the index will be furnished on request. (See § 1120.6(b), *Published indexes*.)

**§ 1120.13 Effect of nonavailability.**

Any material listed in paragraph (a) of this section that is not indexed as required by § 1120.11(e) and § 1120.12, may not be cited, relied on, or used as precedent by the Board to adversely affect any member of the public unless the person against whom it is cited, re-

lied on, or used has had actual and timely notice of the material.

**Subpart D—Information Available Upon Request**

**§ 1120.21 Policy on disclosure of records.**

(a) It is the policy of the A&TBCB to make information available to the public to the greatest extent possible in keeping with the spirit of the Freedom of Information Act. Therefore, all records of the A&TBCB, except those that the A&TBCB specifically determines must not be disclosed in the national interest, for the protection of private rights, or for the efficient conduct of public business to the extent permitted by the Freedom of Information Act, are declared to be available for public inspection and copying as provided in this part. Each member and employee of the A&TBCB is directed to cooperate to this end and to make records available to the public promptly and to the fullest extent consistent with this policy. A record may not be withheld from the public solely because its release might suggest administrative error or embarrass a member or employee of the A&TBCB.

(b) Subject to § 1120.51, any non-exempt A&TBCB record is available to the public upon request regardless of whether the requestor shows any justification or need for the record.

(c) An A&TBCB office may waive the procedures on this subpart in favor of the requestor, for reasons of the public interest, simplicity, or speed.

(d) If a requested record contains both exempt and nonexempt material, the nonexempt material shall be disclosed, after the exempt material has been deleted in accordance with § 1120.42.

**§ 1120.22 Requests to which this subpart applies.**

(a) This subpart applies to any written request (other than a request made by another Federal agency) received by the A&TBCB, whether or not the request cites the Freedom of Information Act, 5 U.S.C. 552, except with respect to records for which a less formal disclosure procedure is provided specifically in this part.

### § 1120.23

(b) Any written request to the A&TBCB for existing records prepared by the A&TBCB for routine public distribution, *e.g.*, pamphlets, copies of speeches, press releases, and educational materials, shall be honored. No individual determination under §1120.32 is necessary in these cases, since preparation of the materials for routine public distribution itself constitutes that a determination that the records are available to the public.

(c) This subpart applies only to records that exist at the time the request for information is made. (See §1120.3, *Existing records.*)

#### § 1120.23 Where requests for agency records must be filed.

A written request for records must be filed with the A&TBCB Freedom of Information Officer, Suite 501, 1111 18th Street NW., Washington, DC 20036. Requests may be mailed to that address or filed in person at that address during the A&TBCB's normal business hours.

[45 FR 80976, Dec. 8, 1980, as amended at 55 FR 2520, Jan. 25, 1990]

#### § 1120.24 Misdirected written requests; oral requests.

(a) The A&TBCB cannot assure that a timely for satisfactory response under this subpart will be given to written requests that are addressed to A&TBCB offices, members, or employees other than the Freedom of Information Officer listed in §1120.23. Any A&TBCB member or employee who receives a written request for inspection or disclosure of A&TBCB records must promptly forward a copy of the request to the Freedom of Information Officer, by the fastest practicable means, and must, if appropriate, commence action under §1120.32.

(b) While A&TBCB members and employees will attempt in good faith to comply with oral requests for inspection or disclosure of A&TBCB records, by telephone or otherwise, these requests are not required to be processed in accordance with this subpart.

#### § 1120.25 Form of requests.

A request must be in writing, must reasonably describe the records sought

### 36 CFR Ch. XI (7-1-03 Edition)

in a way that will permit their identification and location, and must be addressed to the address set forth in §1120.23, but otherwise need not be in any particular form. Each request under the Freedom of Information Act should be clearly and prominently identified by a legend on the first page, such as "Freedom of Information Act Request." The envelope in which the request is sent should be prominently marked with the letters "FOIA." It is helpful, but not necessary, for the requestor to include his or her phone number and the reason for the request. A request may state the maximum amount of fees which the requester is willing to pay. Under §1120.33(d), the failure to state willingness to pay fees as high as are anticipated by the A&TBCB will delay running of the time limit and delay processing of the request, if the responsible official anticipates that the fees chargeable may exceed \$250.00.

[45 FR 80976, Dec. 8, 1980, as amended at 52 FR 43195, Nov. 10, 1987]

#### § 1120.26 Deficient descriptions.

(a) If the description of the records sought in the request is not sufficient to allow the A&TBCB to identify and locate the requested records, the office taking action under §1120.32 must notify the requestor (by telephone when practicable) that the request cannot be further processed until additional information is furnished.

(b) The A&TBCB must make every reasonable effort to assist the requestor in formulating his or her request. If a request is described in general terms (*e.g.*, all records having to do with a certain area), the A&TBCB office taking action under §1120.32 may communicate with the requestor (by telephone when practicable) with a view toward reducing the administrative burden of processing a broad request and minimizing the fee payable by the requestor. Such attempts must not be used as a means to discourage requests, but rather as a means to help identify with more specificity the records actually sought.

**§ 1120.31 A&TBCB receipt of requests; responsibilities of Freedom of Information Officer.**

(a) Upon receipt of a written request, the Freedom of Information Officer must mark the request with the date of receipt and must attach to the request a control slip indicating the Request Identification Number and other pertinent administrative information. The Freedom of Information Officer must immediately forward the request and control slip to the A&TBCB office which the FOIA Officer believes to be responsible for maintaining the records requested. The Freedom of Information Officer must retain a full copy of the request and control slip and must monitor the handling of the request to ensure a timely response.

(b) The Freedom of Information Officer must maintain a file concerning each request received. The file must contain a copy of the request, initial and appeal determinations, and other pertinent correspondence and records.

(c) The Freedom of Information Officer must collect and maintain the information necessary to compile the reports required by 5 U.S.C. 552(d).

**§ 1120.32 A&TBCB action on requests.**

(a) The FOIA Officer is delegated the authority to issue initial determinations concerning records which he or she believes are in the custody of a Board member, an employee of a member's agency, or an employee of a public member. When the FOIA Officer receives such a request, he or she shall forward it to the member, employee of a member agency, or employee of a public member whom the FOIA Officer believes to have custody of the records, requesting the records. The person to whom the request is forwarded shall, within three days of receipt of the FOIA Officer's request, either furnish the records requested to the FOIA Officer or inform the FOIA Officer of the time when they will be furnished. The FOIA Officer shall then determine whether or not to disclose the documents. For purposes of such requests and their processing under this subpart, the FOIA Officer is considered the office handling the requests.

(b) Heads of staff offices are delegated the authority to issue initial de-

terminations, other records which are in their respective custody.

(c) Whenever an A&TBCB office receives a request forwarded by the FOIA Officer, the office should:

(1) Take action under § 1120.26, if required, to obtain a better description of the records requested;

(2) Locate the records as promptly as possible, or determine that:

(i) The records are not known to exist; or

(ii) They are located at another A&TBCB office; or

(iii) They are located at another Federal agency and not possessed by the A&TBCB.

(3) When appropriate, take action under § 1120.53(b) to obtain payment or assurance of payment;

(4) Determine which of the requested records legally must be withheld, and why (see § 1120.42(b), *Release of exempt documents*);

(5) Of the requested records which are exempt from mandatory disclosure but which legally may be disclosed (see § 1120.42(a)), determine which records will be withheld, and why;

(6) Issue an initial determination within the allowed period (see § 1120.31), specifying (individually or by category) which records will be disclosed and which will be withheld, and signed by a person authorized to issue the determination under paragraph (a) of this section (see § 1120.33, *Initial denials of requests*);

(7) Furnish the Freedom of Information Officer a copy of the determination; and

(8) If the determination denies a request, furnish the Freedom of Information Officer the name of the A&TBCB member(s) or employee(s) having custody of the records and maintain the records in a manner permitting their prompt forwarding to the General Counsel upon request if an appeal from the initial denial is filed. (See also § 1120.34.)

(d) If it appears that some or all of the requested records are not in the possession of the A&TBCB office which has been assigned responsibility for responding to the request but may be in the possession of some A&TBCB office, the responding office must so inform

### § 1120.33

### 36 CFR Ch. XI (7-1-03 Edition)

the Freedom of Information officer immediately.

(e) An initial determination to disclose documents must provide the requested documents or provide the opportunity to inspect and/or obtain copies of the documents.

#### § 1120.33 Time allowed for initial action on requests.

(a) Except as otherwise provided in this section, as soon as possible and not later than the tenth working day after the day on which the Freedom of Information Officer receives a request for records, the A&TBCB office responsible for responding to the request must issue a written determination to the requestor stating which of the requested records, will, and which will not, be released and the reason for any denial of a request.

(b) The period of 10 working days is measured from the date the request is first received and logged in by the Freedom of Information Officer.

(c) There is excluded from the period of 10 working days (or any extension) any time which elapses between the date that a requestor is notified by the A&TBCB under § 1120.26 that his or her request does not reasonably identify the records sought, and the date that the requestor furnishes a reasonable identification.

(d) There is excluded from the period of 10 working days (or any extension) any time which elapses between the date that a requestor is notified by an A&TBCB office under § 1120.53(b) that prepayment of fees is required, and the date that the requestor pays (or makes suitable arrangements to pay) the charges.

(e) The A&TBCB office taking action under § 1120.31 may extend the basic 10-day period established under paragraph (a) of this section by a period not to exceed 10 additional working days if—

(1) The office notifies the Freedom of Information Officer;

(2) The office notifies the requestor in writing within the basic 10-day period stating the reasons for the extension and the date by which the office expects to be able to issue a determination;

(3) The extension is reasonably necessary to properly process the particular request; and

(4) One or more of the following unusual circumstances require the extension:

(i) There is a need to search for and collect the requested records from field facilities or other establishments that are separate from the office processing the request;

(ii) There is a need to search for, collect, and/or appropriately examine a voluminous amount of separate and distinct records which are demanded in a single request; or

(iii) There is need for consultation with another agency having a substantial interest in the determination of the request or among two or more components of the A&TBCB. The office must conduct the consultation with all practicable speed.

(f) Should the A&TBCB fail to issue a determination within the 10-day period or any authorized extension as to an initial request, or during the period for consideration of an appeal, the requestor shall be deemed to have exhausted his or her administrative remedies with respect to such.

In the latter situation, the requestor may commence an action in an appropriate Federal district court to obtain the records.

#### § 1120.34 Initial denials of requests.

(a) An initial denial of a request may be issued only for the following reasons:

(1) The record is not under the A&TBCB's control;

(2) The record has been published in the FEDERAL REGISTER or is otherwise published and available for sale;

(3) A statutory provision, provision of this part, or court order requires that the information not be disclosed;

(4) The record is exempt from mandatory disclosure under 5 U.S.C. 552(b) and the responding office has decided not to disclose it under §§ 1120.41 and 1120.42;

(5) The record is believed to be in the A&TBCB's custody but has not yet been located. (See paragraph (f) of this section.)

(b) Each initial denial of a request shall—

- (1) Be written, signed, and dated;
  - (2) Contain a reference to the Request Identification Number;
  - (3) Identify the records that are being withheld (individually or, if the denial covers a large number of similar records, by described category); and
  - (4) State the basis for denial of each record of category of records or any reasonably segregable portion(s) thereof being withheld.
- (c) If the issuance of the determination to deny a request was directed by some A&TBCB officer or employee other than the person signing the determination letter, that other person's identity and position must be stated in the determination letter.
- (d) Each initial determination which denies, in whole or in part, a request for one or more existing, located A&TBCB records must state that the requestor may appeal the initial denial by sending a written appeal to the address shown in §1120.23 within 30 days of receipt of the determination. (See §1120.36.)
- (e) A determination is deemed issued on the date the determination letter is placed in A&TBCB mailing channels for first class mailing to the requestor, delivered to the U.S. Postal Service for mailing, or personally delivered to the requestor, whichever date first occurs.
- (f) When a request must be denied because the record has not yet been located (although it is believed to be in the A&TBCB's possession), the A&TBCB office responsible for maintaining the record must continue to search diligently until it is located or it appears that the record does not exist or is not in the A&TBCB's possession, and must periodically inform the requestor of the office's progress.

**§ 1120.36 Appeals from initial denials.**

- (a) Any person whose request has been denied in whole or in part by an initial determination may appeal that denial by addressing a written appeal to the address shown in §1120.23.
- (b) Any appeal must be mailed or filed in person at the address shown in §1120.23—
  - (1) In the case of a denial of an entire request, generally not later than 30 calendar days after the date the requestor

received the initial determination on the request; or

- (2) In the case of a partial denial, generally not later than 30 calendar days after the requestor receives all records being made available pursuant to the initial determination.

An appeal which does not meet the requirements of this paragraph may be treated either as a timely appeal or as a new request, at the option of the Freedom of Information Officer.

- (c) The appeal letter must contain—
  - (1) A reference to the Request Identification Number (RIN);
  - (2) The date of the initial determination;
  - (3) The name and address of the person who issued the initial denial;
  - (4) A statement of which of the records to which access was denied are the subjects of the appeal; and
  - (5) If the applicant wishes, such facts and legal or other authorities as he or she considers appropriate.

**§ 1120.37 A&TBCB action on appeals.**

- (a) The General Counsel must make one of the following legal determinations in connection with every appeal from the initial denial of a request for an existing, located record:
  - (1) The record must be disclosed;
  - (2) The record must not be disclosed because a statute or a provision of this part so requires; or
  - (3) The record is exempt from mandatory disclosure but legally may be disclosed as a matter of agency discretion.
- (b) Whenever the General Counsel has determined under paragraph (a)(3) of this section that a record is exempt from mandatory disclosure but legally may be disclosed, the matter must be referred to the Executive Director. If the Executive Director determines that an important purpose would be served by withholding the record, the General Counsel shall issue a determination denying the appeal. If the Executive Director determines that no important purpose would be served by withholding the record, the General Counsel must disclose the record.
- (c) The General Counsel may delegate his or her authority under this section to any other attorney employed by the A&TBCB in connection

**§ 1120.38**

**36 CFR Ch. XI (7-1-03 Edition)**

with any category of appeals or any individual appeals.

(d) A determination denying an appeal from an initial denial must—

- (1) Be in writing;
- (2) State which of the exemptions in 5 U.S.C. 552(b) apply to each requested existing record;
- (3) State the reason(s) for denial of the appeal;
- (4) State the name and position of each A&TBCB officer or employee who directed that the appeal be denied; and
- (5) State that the person whose request was denied may obtain de novo judicial review of the denial by complaint filed with the district court of the United States in the district in which the complainant resides, or in which the agency records are situated, or in the District of Columbia, pursuant to 5 U.S.C. 552(a)(4).

**§ 1120.38 Time allowed for action on appeals.**

(a) Except as otherwise provided in this section, as soon as possible and not later than the twentieth working day after the day on which the Freedom of Information Officer receives an appeal from an initial denial of a request for records, the General Counsel shall issue a written determination stating which of the requested records (as to which appeal was made) will and which will not be disclosed.

(b) The period of 20 working days shall be measured from the date an appeal is first received by the Freedom of Information Officer.

(c) The General Counsel may extend the basic 20-day period established under paragraph (a) of this section by a period not to exceed 10 additional working days if—

- (1) He or she notifies the Freedom of Information Officer;
- (2) He or she notifies the requestor in writing within the basic 20-day period stating the reasons for the extension and the date by which he or she expects to be able to issue a determination;
- (3) The extension is reasonably necessary to properly process the particular request; and
- (4) One or more of the following unusual circumstances require the extension:

(i) There is a need to search for and collect the records from field facilities or other establishments that are separated from the office processing the appeal;

(ii) There is a need to search for, collect, and/or appropriately examine a voluminous amount of separate and distinct records which are demanded in a single request; or

(iii) There is a need for consultation with another agency or among two or more components of the A&TBCB. The General Counsel must conduct the consultation with all practicable speed.

(d) No extension of the 20-day period may be issued under paragraph (c) of this section which would cause the total of all such extensions and of any extensions issued under § 1120.33(c) to exceed 10 working days.

**§ 1120.41 Exempt documents.**

(a) Generally, 5 U.S.C. 552(b) establishes nine exclusive categories of matters which are exempt from the mandatory disclosure requirements of 5 U.S.C. 552(a). No request under 5 U.S.C. 552 for an existing, located, unpublished record in the A&TBCB's control may be denied by any A&TBCB office or employee unless the record contains (or its disclosure would reveal) matters that are—

(1) Specifically authorized under criteria established by an Executive order to be kept secret in the interest of national defense or foreign policy and which are in fact properly classified pursuant to the Executive order;

(2) Related solely to the internal personnel rules and practices of an agency;

(3) Specifically exempted from disclosure by statute;

(4) Trade secrets and commercial or financial information obtained from a person and privileged or confidential;

(5) Interagency or intra-agency memorandums or letters which would not be available by law to a party other than an agency in litigation with the agency;

(6) Personnel and medical files and similar files the disclosure of which would constitute a clearly unwarranted invasion of personal privacy;

(7) Investigatory records compiled for law enforcement purposes, but only to



the extent that the production of such records would—

- (i) Interfere with enforcement proceedings;
  - (ii) Deprive a person of a right to a fair trial or an impartial adjudication;
  - (iii) Constitute an unwarranted invasion of personal privacy;
  - (iv) Disclose the identity of a confidential source and, in the case of a record compiled by a criminal law enforcement authority in the course of a criminal investigation or by an agency conducting a lawful national security intelligence investigation, confidential information furnished only by the confidential source;
  - (v) Disclose investigative techniques and procedures; or
  - (vi) Endanger the life or physical safety of law enforcement personnel;
- (8) Contained in or related to examination, operating, or condition reports prepared by, on behalf of, or for the use of an agency responsible for the regulation or supervision of financial institutions; or
- (9) Geological and geophysical information and data, including maps, concerning wells.

(b) The fact that the applicability of an exemption permits the withholding of a requested record (or portion of a record) does not necessarily mean that the record must or should be withheld. (See § 1120.42 *Release of exempt documents.*)

**§ 1120.42 Release of exempt documents.**

(a) An A&TBCB office may, in its discretion, release requested records despite the applicability of one or more of the exemptions listed in § 1120.41 (a)(2), (5), or (7). Disclosure of such records is encouraged if no important purpose would be served by withholding the records.

(b) Though the policy of the A&TBCB is to honor all requests, as indicated in § 1120.21(a), there are circumstances when the A&TBCB will not disclose a record if one or more of the FOIA exemptions applies to the record. The exemptions usually in such circumstances are exemptions (2), (3), (4), (6), (8) and (9). In these cases, where the A&TBCB has withheld a requested record, or portions thereof, the

A&TBCB will disclose the exempted record when ordered to do so by a Federal court or in exceptional circumstances under appropriate restrictions with the approval of the Office of General Counsel.

**Subpart E—Copies of Records and Fees for Services**

**§ 1120.51 Charges for services, generally.**

(a) It shall be the policy of the ATBCB to comply with requests for documents made under the FOIA using the most efficient and least costly methods available. Requesters will be charged fees, in accordance with the administrative provisions and fee schedule set forth below, for searching for, reviewing (in the case of commercial use requesters only), and duplicating requested records.

(b) *Categories of requesters.* For the purpose of standard FOIA fee assessment, the four categories of requesters are: Commercial use requesters; educational and non-commercial scientific institution requesters; requesters who are representatives of the news media; and, all other requesters (see § 1120.2 (l) through (o), Definitions).

(c) *Levels of fees.* Levels of fees prescribed for each category of requester are as follows:

(1) Commercial Use Requesters—When the ATBCB receives a request for documents which appears to be a request for commercial use, the Board may assess charges in accordance with the fee schedule set forth below, which recover the full direct costs of searching for, reviewing for release, and duplicating the records sought. Costs for time spent reviewing records to determine whether they are exempt from mandatory disclosure applies to the initial review only. No fees will be assessed for reviewing records, at the administrative appeal level, of the exemptions already applied.

(2) Educational and Non-Commercial Scientific Institution Requesters—The ATBCB shall provide documents to requesters in this category for the cost of reproduction alone, in accordance with the fee schedule set forth below, excluding charges for the first 100 pages of reproduced documents.

§ 1120.52

36 CFR Ch. XI (7-1-03 Edition)

(i) To be eligible for inclusion in this category, requesters must demonstrate the request is being made under the auspices of a qualifying institution and that the records are not sought for a commercial use, but are sought in furtherance of scholarly (if the request is from an educational institution) or scientific (if the request is from a non-commercial scientific institution) research.

(ii) Requesters eligible for free search must reasonably describe the records sought.

(3) Requesters Who Are Representatives of the News Media—The ATBCB shall provide documents to requesters in this category for the cost of reproduction alone, in accordance with the fee schedule set forth below, excluding charges for the first 100 pages of reproduced documents.

(4) All Other Requestors—The ATBCB shall charge requestors who do not fit into any of the categories described above, fees which recover the full direct cost of searching for and reproducing records that are responsive to the request, except that the first two hours of search time and the first 100 pages of reproduction shall be furnished without charge.

(d) Schedule of FOIA fees.

(1) Record search (ATBCB employees)—\$14.00 per hour

(2) Document review (ATBCB employees)—\$20.00 per hour

(3) Duplication of documents (paper copy of paper original)—\$.20 per page

(e) No charge shall be made:

(1) If the costs of routine collection and processing of the fee are likely to equal or exceed the amount of the fee;

(2) For any request made by an individual or group of individuals falling into the categories listed at paragraph (b) of this section, and described in paragraph (c) of this section, (excepting commercial use requests) the first two hours of search time and first 100 pages of duplication;

(3) For the cost of preparing or reviewing letters of response to a request or appeal;

(4) For responding to a request for one copy of the official personnel record of the requestor;

(5) For furnishing records requested by either House of Congress, or by duly

authorized committee or subcommittee or Congress, unless the records are requested for the benefit of an individual Member of Congress or for a constituent;

(6) For furnishing records requested by and for the official use of other Federal agencies; or

(7) For furnishing records needed by an A&TBCB contractor or grantee to perform the work required by the A&TBCB contract or grant.

(f) Requestors may be charged for unsuccessful or unproductive searches or for searches when records located are determined to be exempt from disclosure.

(g) Where the ATBCB reasonably believes that a requestor or group of requestors is attempting to break a request down into a series of requests for the purpose of evading the assessment of fees, the ATBCB shall aggregate any such requests and charge accordingly.

[55 FR 2520, Jan. 25, 1990]

§ 1120.52 Computerized records.

(a) Information available in whole or in part in computerized form which is disclosable under the Freedom of Information Act is available to the public as follows:

(1) When there is an existing printout from the computer which permits copying the printout, the material will be made available at the per page rate stated in §1120.51(a) for each 8½ by 11 inch page.

(2) When there is not an existing printout of information disclosable under the Freedom of Information Act, a printout shall be made if the applicant pays the cost to the A&TBCB as stated in paragraph (a)(3) of this section.

(3) Obtaining information from computerized records frequently involves a minimum computer time cost of approximately \$100 per request. Multiple requests involving the same subject may cost less per request. Services of personnel in the nature of a search shall be charged for at rates prescribed in §1120.51(a). A charge shall be made for the computer time involved based upon the prevailing level of costs to Government organizations and upon the particular types of computer and associated equipment and the amounts

of time on such equipment that are utilized. A charge shall also be made for any substantial amounts of special supplies or materials used to contain, present, or make available the output of computers based upon the prevailing levels of costs to Government organizations and upon the type and amount of the supplies and materials that are used.

(b) Information in the Board's computerized records which could be produced only by additional programming of the computer, thus producing information not previously in being, is not required to be furnished under the Freedom of Information Act. In view of the usually heavy workloads of the computers used by the Board, such a service cannot ordinarily be offered to the public.

**§ 1120.53 Payment of fees.**

(a) *Method of payment.* All fee payments shall be in the form of a check or money order payable to the order of the "U.S. Architectural and Transportation Barriers Compliance Board" and shall be sent (accompanied by a reference to the pertinent Request Identification Number(s)) to the address in § 1120.23.

(b) *Charging interest.* The ATBCB may charge interest to those requestors failing to pay fees assessed in accordance with the procedures described in § 1120.51. Interest charges, computed at the rate prescribed in section 3717 of title 31 U.S.C.A., will be assessed on the full amount billed starting on the 31st day following the day on which the bill was sent.

(c) *Advance payment or assurance of payment.* (1) When an ATBCB office determines or estimates that the allowable charges a requestor may be required to pay are likely to exceed \$250.00, the ATBCB may require the requestor to make an advance payment or arrangements to pay the entire fee before continuing to process the request. The ATBCB shall promptly inform the requestor (by telephone, if practicable) of the need to make an advance payment or arrangements to pay the fee. That office need not search for, review, duplicate, or disclose records in response to any request by that requestor until he or she pays, or makes

acceptable arrangements to pay, the total amount of fees due (or estimated to become due) under this subpart.

(2) Where a requestor has previously failed to pay a fee charged in a timely fashion, the ATBCB may require the requestor to pay the full amount owed, plus any applicable interest, as provided in paragraph (b) of this section, and to make an advance payment of the full amount of the estimated fee before any new or pending requests will be processed from that requestor.

(3) In those instances described in paragraphs (c)(1) and (2) of this section, the administrative time limits prescribed in § 1120.33(d) will begin only after the ATBCB has received all fee payments due or acceptable arrangements have been made to pay all fee payments due.

(d) *Effect of the Debt Collection Act of 1982 (Pub. L. 97-365).* Requestors are advised that the ATBCB shall use the authorities of the Debt Collection Act of 1982, including disclosure to consumer reporting agencies and use of collection agencies, where appropriate, to encourage repayment of debts arising from freedom of information act requests.

(e) *Waiver or reduction of fees.* (1) Records responsive to a request under 5 U.S.C. 552 shall be furnished without charge or at a charge reduced below that established under paragraph (d) of § 1120.51 where the Freedom of Information Officer determines, based upon information provided by a requestor in support of a fee waiver request or otherwise made known to the Freedom of Information Officer, that disclosure of the requested information is in the public interest because it is likely to contribute significantly to public understanding of the operations or activities of the government and is not primarily in the commercial interest of the requestor. Requests for a waiver or reduction of fees shall be considered on a case-by-case basis.

(2) In order to determine whether the first fee waiver requirement is met—i.e., that disclosure of the requested information is in the public interest because it is likely to contribute significantly to public understanding of the operations or activities of the government—Freedom of Information Officer

shall consider the following four factors in sequence:

(i) The subject of the request: Whether the subject of the requested records concerns “the operations or activities of the government.” The subject matter of the requested records, in the context of the request, must specifically concern identifiable operations or activities of the federal government—with a connection that is direct and clear, not remote or attenuated. Furthermore, the records must be sought for their informative value with respect to those government operations or activities; a request for access to records for their intrinsic informational content alone will not satisfy this threshold consideration.

(ii) The informative value of the information to be disclosed: Whether the disclosure is “likely to contribute” to an understanding of government operations or activities. The disclosable portions of the requested records must be meaningfully informative on specific government operations or activities in order to hold potential for contributing to increase public understanding of those operations and activities. The disclosure of information that already is in the public domain, in either a duplicative or a substantially identical form, would not be likely to contribute to such understanding, as nothing new would be added to the public record.

(iii) The contribution to an understanding of the subject by the public likely to result from disclosure: Whether disclosure of the requested information will contribute to “public understanding.” The disclosure must contribute to the understanding of the public at large, as opposed to the individual understanding of the requestor or a narrow segment of interested persons. A requestor’s identity and qualifications—e.g., expertise in the subject area and ability and intention to effectively convey information to the general public—should be considered. It reasonably may be presumed that a representative of the news media (as defined in §1120.2(o)) who has access to the means of public dissemination readily will be able to satisfy this consideration. Requests from libraries or other record repositories (or requestors

who intend merely to disseminate information to such institutions) shall be analyzed, like those of other requestors to identify a particular person who represents that he actually will use the requested information in scholarly or other analytic work and then disseminate it to the general public.

(iv) The significance of the contribution to public understanding: Whether the disclosure is likely to contribute “significantly” to public understanding of government operations or activities. The public’s understanding of the subject matter in question, as compared to the level of public understanding existing prior to the disclosure, must be likely to be enhanced by the disclosure to a significant extent. Freedom of Information Officer shall not make separate value judgments as to whether information, even though it in fact would contribute significantly to public understanding of the operations or activities of the government, is “important” enough to be made public.

(3) In order to determine whether the second fee waiver requirement is met—i.e., that disclosure of the requested information is not primarily in the commercial interest of the requestor—the Freedom of Information Officer shall consider the following two factors in sequence:

(i) The existence and magnitude of a commercial interest: Whether the requestor has a commercial interest that would be furthered by the requested disclosure. The Freedom of Information Officer shall consider all commercial interests of the requester (with reference to the definition of “commercial use” in §1120.2(l)) or any person on whose behalf the requestor may be acting, but shall consider only those interests which would be furthered by the requested disclosure. In assessing the magnitude of identified commercial interests, consideration shall be given to the role that such FOIA-disclosed information plays with respect to those commercial interests, as well as to the extent to which FOIA disclosures serve those interests overall. Requestors shall be given a reasonable opportunity in the administrative process to provide information bearing upon this consideration.

(ii) The primary interest in disclosure: Whether the magnitude of the identified commercial interest of the requestor is sufficiently large, in comparison with the public interest in disclosure, that disclosure is “primarily in the commercial interest of the requestor.” A fee waiver or reduction is warranted only where, once the “public interest” standard set out in paragraph (e)(2) of this section is satisfied, that public interest can fairly be regarded as greater in magnitude than that of the requestor’s commercial interest in disclosure. The Freedom of Information Officer shall ordinarily presume that where a news media requestor has satisfied the “public interest” standard, that will be the interest primarily served by disclosure to that requestor. Disclosure to data brokers or others who compile and market government information for direct economic return shall not be presumed to primarily serve “public interest.”

(4) Where only a portion of the requested records satisfies both of the requirements for a waiver or reduction of fees under this paragraph, a waiver or reduction shall be granted only as to that portion.

(5) Requests for the waiver or reduction of fees shall address each of the factors listed in paragraphs (e) (2) and (3) of this section, as they apply to each record request. One hundred pages of reproduction shall be furnished without charge.

(6) A request for reduction or waiver of fees shall be addressed to the Freedom of Information Officer at the address shown in §1120.23. The ATBCB office which is responding to the request for records shall initially determine whether the fee shall be reduced or waived and shall so inform the requestor. The initial determination may be appealed by letter addressed to the address shown in §1120.23. The General Counsel or his or her designee shall decide such appeals.

[45 FR 80976, Dec. 8, 1980, as amended at 52 FR 43196, Nov. 10, 1987; 55 FR 2521, Jan. 25, 1990]

## PART 1121—PRIVACY ACT IMPLEMENTATION

### Sec.

- 1121.1 Purpose and scope.
- 1121.2 Definitions.
- 1121.3 Procedures for requests pertaining to individuals’ records in a records system.
- 1121.4 Times, places, and requirements for the identification of the individual making a request.
- 1121.5 Access to requested information to the individual.
- 1121.6 Request for correction or amendment to the record.
- 1121.7 Agency review of request for correction or amendment of the record.
- 1121.8 Appeal of an initial adverse agency determination on correction or amendment of the record.
- 1121.9 Notification of dispute.
- 1121.10 Disclosure of record to a person other than the individual to whom the record pertains.
- 1121.11 Accounting of disclosures.
- 1121.12 Fees.

AUTHORITY: 5 U.S.C. 552a; Pub. L. 93-579.

SOURCE: 50 FR 3905, Jan. 29, 1985, unless otherwise noted.

### § 1121.1 Purpose and scope.

The purposes of these regulations are to:

(a) Establish a procedure by which an individual can determine if the Architectural and Transportation Barriers Compliance Board, hereafter known as the Board or ATBCB, maintains a system of records which includes a record pertaining to the individual; and

(b) Establish a procedure by which an individual can gain access to a record pertaining to him or her for the purpose of review, amendment and/or correction.

### § 1121.2 Definitions.

For the purpose of these regulations—

(a) The term *individual* means a citizen of the United States or an alien lawfully admitted for permanent residence.

(b) The term *maintain* includes maintain, collect, use or disseminate.

(c) The term *record* means any item, collection or grouping of information about an individual that is maintained

**§ 1121.3**

by the Board, including, but not limited to, his or her employment history, payroll information, and financial transactions and that contains his or her name, or the identifying number, symbol, or other identifying particular assigned to the individual, such as social security number.

(d) The term *system of records* means a group of any records under control of the Board from which information is retrieved by the name of the individual or by some identifying number, symbol, or other identifying particular assigned to the individual.

(e) The term *routine use* means, with respect to the disclosure of a record, the use of such record for a purpose which is compatible with the purpose for which it was collected.

(f) The term *authorized representative* means a person who acts on an *individual's* behalf for purposes of these regulations, pursuant to written, signed instructions from the individual.

**§ 1121.3 Procedures for requests pertaining to individuals' records in a records system.**

An individual or authorized representative shall submit a written request to the Administrative Officer to determine if a system of records named by the individual contains a record pertaining to the individual. The individual or authorized representative shall submit a written request to the Executive Director of the ATBCB which states the individual's desire to review his or her record.

**§ 1121.4 Times, places, and requirements for the identification of the individual making a request.**

An individual or authorized representative making a request to the Administrative Officer of the ATBCB pursuant to § 1121.3 shall present the request at the ATBCB offices, 330 C Street, SW., Room 1010, Washington, DC 20202, on any business day between the hours of 9 a.m. and 5:30 p.m. The individual or authorized representative submitting the request should present himself or herself at the ATBCB's offices with a form of identification which will permit the ATBCB to verify that the individual is the same individual as contained in the record re-

quested. An authorized representative shall present a written document authorizing access. The document must be signed by the individual.

**§ 1121.5 Access to requested information to the individual.**

Upon verification of identity the Board shall disclose to the individual or authorized representative the information contained in the record which pertains to that individual. Nothing in this section shall allow an individual access to any information compiled in reasonable anticipation of a civil action or proceeding.

**§ 1121.6 Request for correction or amendment to the record.**

The individual or authorized representative should submit a request to the Administrative Officer which states the individual's desire to correct or to amend his or her record. This request is to be made in accord with provisions of § 1121.4.

**§ 1121.7 Agency review of request for correction or amendment of the record.**

Within ten working days of the receipt of the request to correct or to amend the record, the Administrative Officer will acknowledge in writing such receipt and promptly either—

(a) Make any correction or amendment of any portion thereof which the individual believes is not accurate, relevant, timely, or complete; or

(b) Inform the individual or authorized representative of his or her refusal to correct or to amend the record in accordance with the request, the reason for the refusal and the procedures established by the Board for the individual to request a review of that refusal.

**§ 1121.8 Appeal of an initial adverse agency determination on correction or amendment of the record.**

An individual who disagrees with the refusal of the Administrative Officer to correct or to amend his or her record may submit a request for a review of such refusal to the Executive Director, ATBCB, 330 C Street, SW., Room 1010, Washington, DC 20202. The Executive Director will, not later than thirty (30)

working days from the date on which the individual requests such review, complete such review and make final determination, unless, for good cause shown, the Executive Director extends such thirty-day period. If, after his or her review, the Executive Director also refuses to correct or to amend the record in accordance with the request, the Board shall permit the individual or authorized representative to file with the Executive Director a concise statement setting forth the reasons for his or her disagreement with the refusal of the Executive Director and shall notify the individual or authorized representative that he or she may seek judicial review of the Executive Director's determination under 5 U.S.C. 552a(g)(1)(A).

**§ 1121.9 Notification of dispute.**

In any disclosure pursuant to § 1121.10 containing information about which the individual has previously filed a statement of disagreement under § 1121.8, the Board shall clearly note any portion of the record which is disputed and provide copies of the statement and, if the Executive Director deems it appropriate, copies of a concise statement of the reasons of the Executive Director for not making the amendments requested.

**§ 1121.10 Disclosure of record to a person other than the individual to whom the record pertains.**

The Board will not disclose a record to any individual or agency other than the individual to whom the record pertains, except to an authorized representative, unless the disclosure has been listed as a "routine use" in the Board's notices of its systems of records, or falls within one of the special disclosure situations listed in the Privacy Act of 1974 (5 U.S.C. 552a(b)).

**§ 1121.11 Accounting of disclosures.**

(a) The Board shall, except for disclosure made under sections (b)(1) and (b)(2) of the Privacy Act of 1974 (5 U.S.C. 552a) keep an accurate accounting of—

(1) The date, nature and purpose of each disclosure of a record to any person or another agency made pursuant to § 1121.10; and

(2) The name and address of the person or agency to whom the disclosure is made.

(b) This accounting shall be retained for at least five years or the life of the record, whichever is longer, after the disclosure for which the accounting is made;

(c) The Board shall make this accounting available to the individual named in the record at his or her request, except for disclosures made under section (b)(7) of the Privacy Act of 1974 (5 U.S.C. 552a).

(d) The Board shall inform any person or other agency to whom disclosure has been made pursuant to § 1121.10 about any correction or notation of dispute made by the Board.

**§ 1121.12 Fees.**

If an individual or authorized representative requests copies of his or her record, he or she shall be charged ten cents per page, excluding the cost of any search for review of the record, in advance of receipt of the pages.

**PART 1150—PRACTICE AND PROCEDURES FOR COMPLIANCE HEARINGS**

**Subpart A—General Information**

- Sec.
- 1150.1 Purpose.
- 1150.2 Applicability: Buildings and facilities subject to guidelines and standards.
- 1150.3 Policy of amicable resolution.
- 1150.4 Definitions.
- 1150.5 Scope and interpretation of rules.
- 1150.6 Suspension of rules.

**Subpart B—Parties, Complainants, Participants**

- 1150.11 Parties.
- 1150.12 Complainants.
- 1150.13 Participation on petition.
- 1150.14 Appearance.

**Subpart C—Form, Execution, Service and Filing of Documents for Proceedings on Citations**

- 1150.21 Form of documents to be filed.
- 1150.22 Signature of documents.
- 1150.23 Filing and service.
- 1150.24 [Reserved]
- 1150.25 Date of service.
- 1150.26 Certificate of service.

## § 1150.1

## 36 CFR Ch. XI (7-1-03 Edition)

### Subpart D—Time

- 1150.31 Computation.
- 1150.32 Extension of time or postponement.

### Subpart E—Proceedings Prior to Hearings; Pleadings and Motions

- 1150.41 Informal resolution.
- 1150.42 Citations.
- 1150.43 Answers.
- 1150.44 Amendments.
- 1150.45 Request for hearing.
- 1150.46 Motions.
- 1150.47 Disposition of motions and petitions.
- 1150.48 PER: Citation, answer, amendment.

### Subpart F—Responsibilities and Duties of Judge

- 1150.51 Who presides.
- 1150.52 Authority of judge.
- 1150.53 Disqualification of judge.

### Subpart G—Prehearing Conferences and Discovery

- 1150.61 Prehearing conference.
- 1150.62 Exhibits.
- 1150.63 Discovery.

### Subpart H—Hearing Procedures

- 1150.71 Briefs.
- 1150.72 Purpose of hearing.
- 1150.73 Testimony.
- 1150.74 Exclusion of evidence.
- 1150.75 Objections.
- 1150.76 Exceptions.
- 1150.77 Official notice.
- 1150.78 Public documents.
- 1150.79 Offer of proof.
- 1150.80 Affidavits.
- 1150.81 Consolidated or joint hearing.
- 1150.82 PER proceedings.

### Subpart I—The Record

- 1150.91 Record for decision.
- 1150.92 Official transcript.

### Subpart J—Posthearing Procedures; Decisions

- 1150.101 Posthearing briefs; proposed findings.
- 1150.102 Decision.
- 1150.103 PER: Posthearing briefs, decision.
- 1150.104 Judicial review.
- 1150.105 Court enforcement.

### Subpart K—Miscellaneous Provisions

- 1150.111 Ex parte communications.
- 1150.112 Post-order proceedings.
- 1150.113 Amicable resolution.
- 1150.114 Effect of partial invalidity.

AUTHORITY: 29 U.S.C. 792, as amended.

SOURCE: 45 FR 78474, Nov. 25, 1980, unless otherwise noted.

### Subpart A—General Information

#### § 1150.1 Purpose.

*Purpose.* The purpose of the regulations in this part is to implement section 502(b)(1) of the Rehabilitation Act of 1973, Pub. L. 93-112, 29 U.S.C. 792, as amended by the Rehabilitation, Comprehensive Services, and Developmental Disabilities Amendments of 1978, Pub. L. 95-602, section 118, 92 Stat. 2979, by establishing rules of procedure for public hearings which ensure compliance with standards issued under the Architectural Barriers Act of 1968, Pub. L. 90-480, as amended, 42 U.S.C. 4151 *et seq.* (including standards of the U.S. Postal Service).

#### § 1150.2 Applicability: Buildings and facilities subject to guidelines and standards.

(a) *Definitions.* As used in this section, the term:

*Constructed or altered on behalf of the United States* means acquired by the United States through lease-purchase arrangement, constructed or altered for purchase by the United States, or constructed or altered for the use of the United States.

*Primarily for use by able-bodied military personnel* means expected to be occupied, used, or visited principally by military service personnel. Examples of buildings so intended are barracks, officers' quarters, and closed messes.

*Privately owned residential structure* means a single or multi-family dwelling not owned by a unit or subunit of Federal, state, or local government.

(b) *Buildings and facilities covered.* Except as provided in paragraph (c) of this section, the standards issued under the Architectural Barriers Act of 1968, Pub. L. 90-480, as amended, 42 U.S.C. 4151 *et seq.* (including standards of the United States Postal Service) apply to any building or facility—

(1) The intended use for which either—

(i) Will require that such building or facility be accessible to the public, or

(ii) May result in employment or residence therein of physically handicapped persons; and



## Architectural and Transp. Barriers Compliance Board

## § 1150.4

(2) Which is—

(i) To be constructed or altered by or on behalf of the United States;

(ii) To be leased in whole or in part by the United States—

(A) After August 12, 1968, and before January 1, 1977, after construction or alteration in accordance with plans and specifications of the United States; or

(B) On or after January 1, 1977, including any renewal of a lease entered into before January 1, 1977, which renewal is on or after such date;

(iii) To be financed in whole or in part by a grant or loan made by the United States after August 12, 1968, if the building or facility may be subject to standards for design, construction, or alteration issued under the law authorizing the grant or loan; or

(iv) To be constructed under the authority of the National Capital Transportation Act of 1960, the National Capital Transportation Act of 1965, or title III of the Washington Metropolitan Area Transit Regulation Compact.

(c) *Buildings and facilities not covered.* The standards do not apply to—

(1) Any privately owned residential structure, unless it is leased by the Federal government on or after January 1, 1977, for subsidized housing programs; or

(2) Any building or facility on a military installation designed and constructed primarily for use by military personnel.

(d) Any covered building or facility, as provided in this section, which is designed, constructed, or altered after the effective date of a standard issued which is applicable to the building or facility, shall be designed, constructed, altered, or leased in accordance with the standard. For purposes of this section, any design, construction, alteration or lease for which bids or offers are received before the effective date of an applicable standard, in response to an invitation for bids or request for proposals, is not subject to that standard.

### § 1150.3 Policy of amicable resolution.

The policy of the Architectural and Transportation Barriers Compliance Board is to maximize the accessibility and usability of buildings, and facili-

ties through amicable means. To this end, the Architectural and Transportation Barriers Compliance Board encourages voluntary and informal resolution of all complaints.

### § 1150.4 Definitions.

*A&TBCB* means the Architectural and Transportation Barriers Compliance Board.

*Agency* means Federal department, agency, or instrumentality as defined in sections 551(1) and 701(b)(1) of title 5 U.S.C., or an agency official authorized to represent the agency. It includes any executive department or independent establishment in the Executive Branch of the government, including wholly owned government corporations, and any establishment in the legislative or judicial branch of the government, except the Senate, the House of Representatives, and the Architect of the Capitol and any activities under his direction.

*Alteration* means any change in a building or facility or its permanent fixtures or equipment. It includes, but is not limited to, remodeling, renovation, rehabilitation, reconstruction, changes or rearrangement in structural parts, and extraordinary repairs. It does not include normal maintenance, reroofing, interior decoration, or changes to mechanical systems.

*Architectural Barriers Act* means the Architectural Barriers Act of 1968, Pub. L. 90-480, as amended, 42 U.S.C. 4151 *et seq.*

*Building or facility* means all or any portion of buildings, structures, equipment, roads, walks, parking lots, parks, sites, or other real property or interest in such property.

*Chair* means the Chair of the A&TBCB.

*Complaint* means any written notice of an alleged violation, whether from an individual or organization, or other written information reasonably indicating to the Executive Director a violation of the standard.

*Construction* means any section of a new building or an addition to an existing building.

*Day* means calendar day.

*Executive Director* means the A&TBCB Executive Director.

## § 1150.5

*Extraordinary repair* means the replacement or renewal of any element of an existing building or facility for purposes other than normal maintenance.

*Judge* means an Administrative Law Judge appointed by the A&TBCB and assigned to the case in accordance with either section 3105 or 3314 of title 5 U.S.C.

*PER* means Provisional Expedited Relief.

*Respondent* means a party answering the citation, including PER Citation.

*Section 502 of the Rehabilitation Act* means section 502 of the Rehabilitation Act of 1973, Pub. L. 93-112, 29 U.S.C. 792, as amended.

*Standard* means any standard for accessibility and usability prescribed under the Architectural Barriers Act.

[53 FR 39473, Oct. 7, 1988]

### § 1150.5 Scope and interpretation of rules.

(a) These rules shall govern all compliance proceedings held before a judge and all alleged violations coming to the Executive Director as a complaint.

(b) In the absence of a specific provision in these rules, procedure shall be in accordance with the Administrative Procedure Act, subchapter II of chapter 5 and chapter 7, of title 5 U.S.C., and the Federal Rules of Civil Procedure, in that order.

(c) These rules and regulations shall be liberally construed to effectuate the purposes and provisions of the Architectural Barriers Act and section 502 of the Rehabilitation Act.

(d) The rules shall be applied to secure fairness in administration and elimination of unjustifiable expense and delay and to ascertain the truth.

(e) Words importing the singular number may extend and be applied to a plural and vice versa.

### § 1150.6 Suspension of rules.

Upon notice to all parties, the judge, with respect to matters pending before him/her, may modify or waive any rule in these regulations upon determination that no party will be unduly prejudiced and that the end of justice will be served.

## 36 CFR Ch. XI (7-1-03 Edition)

### Subpart B—Parties, Complainants, Participants

#### § 1150.11 Parties.

(a) The term parties includes (1) any agency, state or local body, or other person named as a respondent in a notice of hearing or opportunity for hearing, (2) the Executive Director and (3) any person named as a party by order of the judge.

(b) The Executive Director has the sole authority to initiate proceedings by issuing a citation under § 1150.42, on the basis of (1) a complaint from any person or (2) alleged violations coming to his/her attention through any means.

#### § 1150.12 Complainants.

(a) Any person may submit a complaint to the A&TBCB alleging that a building or facility does not comply with applicable standards issued under the Architectural Barriers Act. Complaints must be in writing and should be sent to: Executive Director, Architectural and Transportation Barriers Compliance Board, 1111 18th Street, Suite 501, Washington, DC 20036-3894.

A complaint form is available at the above address. Complaints may, but need not, contain (1) the complainant's name and where he/she may be reached, (2) the facility or building and, if known, the funding agency, and (3) a brief description of the barriers. A complaint form is available at the above address.

(b) The A&TBCB shall hold in confidence the identity of all persons submitting complaints unless the person submits a written authorization otherwise.

(c) The A&TBCB shall give or mail to the complainant a copy of these regulations.

(d) A complainant is not a party to the proceedings as a matter of course, but may petition the judge to participate under § 1150.13.

(e) The A&TBCB shall send the complainant a copy of the final order issued by the judge. The complainant has standing to obtain judicial review of that order.

[53 FR 39473, Oct. 7, 1988]

**§ 1150.13 Participation on petition.**

(a) By petitioning the judge, any person may be permitted to participate in the proceedings when he/she claims an interest in the proceedings and may contribute materially to their proper disposition. A complainant shall be permitted to participate in the proceeding when he/she petitions the judge.

(b) The judge may, in his/her discretion, determine the extent of participation of petitioners, including as an intervening party or participant. The judge may, in his/her discretion, limit participation to submitting documents and briefs, or permit the introduction of evidence and questioning of witnesses.

**§ 1150.14 Appearance.**

(a) A party may appear in person or by counsel or other representative and participate fully in any proceedings. An agency, state or local body, corporation or other association, may appear by any of its officers or by any employee it authorizes to appear on its behalf.

(b) A representative of a party or participant shall be deemed to control all matters respecting the interest of such party or participant in the proceedings.

(c) This section shall not be construed to require any representative to be an attorney-at-law.

(d) Withdrawal of appearance of any representative is effective when a written notice of withdrawal is filed and served on all parties and participants.

**Subpart C—Form, Execution, Service and Filing of Documents for Proceedings on Citations****§ 1150.21 Form of documents to be filed.**

Documents to be filed under the rules in this part shall be dated, the original signed in ink, shall show the docket number and title of the proceeding and shall show the title, if any, and address of the signatory. Copies need not be signed; however, the name of the person signing the original, but not necessarily his/her signature, shall be reproduced. Documents shall be legible

and shall not be more than 8½ inches wide.

**§ 1150.22 Signature of documents.**

The signature of a party, authorized officer, employee or attorney constitutes a certification that he/she has read the document, that to the best of his/her knowledge, information, and belief there is a good ground to support it, and that it is not interposed for delay. If a document is not signed or is signed with intent to defeat the purpose of this section, it may be stricken as sham and false and the proceeding may proceed as though the document had not been filed.

**§ 1150.23 Filing and service.**

(a) *General.* All notices, written motions, requests, petitions, memoranda, pleadings, briefs, decisions, and correspondence to the judge, from a party or a participant or vice versa, relating to a proceeding after its commencement shall be filed and served on all parties and participants.

(b) *Filing.* Parties shall submit for filing the original and two copies of documents, exhibits, and transcripts of testimony. Filings shall be made in person or by mail, with the hearing clerk at the address stated in the notice of hearing or notice of opportunity for hearing, during regular business hours. Regular business hours are every Monday through Friday (Federal legal holidays excepted) from 9 a.m. to 5:30 p.m. Standard or Daylight Savings Time, whichever is effective in the city where the office of the judge is located at the time.

(c) *Service.* Service of one copy shall be made on each party and participant by personal delivery or by certified mail, return receipt requested, properly addressed with postage prepaid. When a party or participant has appeared by attorney or other representative, service upon the attorney or representative is deemed service upon the party or participant.

**§ 1150.24 [Reserved]****§ 1150.25 Date of service.**

The date of service shall be the day when the matter is deposited in United States mail or is delivered in person,

except that the date of service of the initial notice of hearing or opportunity for hearing shall be the date of its delivery, or the date that its attempted delivery is refused.

**§ 1150.26 Certificate of service.**

The original of every document filed and required to be served upon parties to a proceeding shall be endorsed with a certificate of service signed by the party making service or by his/her attorney or representative, stating that such service has been made, the date of service, and the manner of service, whether by mail or personal delivery.

**Subpart D—Time**

**§ 1150.31 Computation.**

In computing any period of time under these rules or in any order issued under them, the time begins with the day following the act, event, or default, and includes the last day of the period, unless it is a Saturday, Sunday, or Federal legal holiday, in which event it includes the next following business day. When the period of time prescribed or allowed is less than seven (7) days, intermediate Saturdays, Sundays, and Federal legal holidays shall be excluded from the computation.

**§ 1150.32 Extension of time or postponement.**

(a) Requests for extension of time shall be addressed to the judge and served on all parties and participants. Requests should set forth the reasons for the application.

(b) If made promptly, answers to requests for extension of time are permitted.

(c) The judge may grant the extension upon a showing of good cause by the applicant.

**Subpart E—Proceedings Prior to Hearings; Pleadings and Motions**

**§ 1150.41 Informal resolution.**

(a) The A&TBCB immediately shall send copies of complaints to all interested agencies and persons. In addition, the A&TBCB shall apprise any person who might become a party to compliance proceedings of the alleged in-

stances of noncompliance and afford him/her a reasonable opportunity to respond or submit pertinent documents.

(b) The Executive Director or his/her designee shall seek the cooperation of persons and agencies in obtaining compliance and shall provide assistance and guidance to help them comply voluntarily.

(c) Upon request of the Executive Director, interested agencies or persons, including, but not limited to, occupant agencies, recipients of assistance, and lessors, shall submit to the Executive Director or his/her designee timely, complete, and accurate reports concerning the particular complaint. Reports shall be completed at such times, and in such form containing all information as the Executive Director or his/her designee may prescribe.

(d) The Executive Director, or his/her designee, shall have access during normal business hours to books, records, accounts and other sources of information and facilities as may be pertinent to ascertain compliance. Considerations of privacy or confidentiality asserted by an agency or person may not bar the Executive Director from evaluating such materials or seeking to enforce compliance. The Executive Director may seek a protective order authorizing the use of allegedly confidential materials on terms and conditions specified by the judge.

(e) Complaints should be resolved informally and expeditiously, by the interested persons or agencies. If compliance with the applicable standards is not achieved informally or an impasse concerning the allegations of compliance or noncompliance is reached, the Executive Director will review the matter, including previous attempts by agencies to resolve the complaint, and take actions including, but not limited to, surveying and investigating buildings, monitoring compliance programs of agencies, furnishing technical assistance, such as standard interpretation, to agencies, and obtaining assurances, certifications, and plans of action as may be necessary to ensure compliance.

(f) All actions to informally resolve complaints under paragraphs (a) through (e) of this section shall be completed within one hundred eighty

(180) days after receipt of the complaint by all affected agencies and persons. A complaint shall be deemed informally resolved if the person or agencies responsible for the alleged violation either:

(1) Demonstrates to the Executive Director that no violation has occurred, or

(2) Corrects the violation, or

(3) Agrees in writing to implement specific compliance action within a definite time agreed to by the Executive Director, or

(4) Are timely implementing a plan for compliance agreed to by the Executive Director.

No later than ten (10) days after the termination of the one hundred eighty (180) day period, the Executive Director shall either issue a citation under § 1150.42, or determine in writing that a citation will not be issued at that time and the reasons that it is considered unnecessary.

(g) A determination not to issue a citation shall be served in accordance with § 1150.23 on all interested agencies and persons upon whom a citation would have been served if it had been issued. Except as otherwise provided in paragraph (i) of this section, the failure of the Executive Director to take action within the ten (10) day period after termination of the one hundred eighty (180) day informal resolution period shall not preclude the Executive Director from taking action thereafter.

(h) Nothing in paragraphs (a) through (g) of this section shall be construed as precluding the Executive Director before the termination of the one hundred eighty (180) day informal resolution period from:

(1) Issuing a citation if it is reasonably clear that informal resolution cannot be achieved within that time, or

(2) Determining not to issue a citation if it is reasonably clear that compliance can be achieved or that issuance of a citation is not otherwise warranted.

(i) At any time after the expiration of one hundred ninety (190) days after receipt of the complaint by all affected agencies and persons, any person or agency receiving a copy of the complaint, or the complainant, may serve a

written request on the Executive Director to issue a citation or determination not to proceed within thirty (30) days. If the Executive Director fails to serve a written response within thirty (30) days of receipt of such a request, the complaint shall be deemed closed.

[53 FR 39474, Oct. 7, 1988]

#### § 1150.42 Citations.

(a) If there appears to be a failure or threatened failure to comply with a relevant standard, and the noncompliance or threatened noncompliance cannot be corrected or resolved by informal means under § 1150.41, the Executive Director on behalf of the A&TBCB may issue a written citation, requesting the ordering of relief necessary to ensure compliance with the standards or guidelines and requirements. The relief may include the suspension or withholding of funds and/or specific corrective action.

(b) The citation shall be served upon all interested parties, as appropriate, including but not limited to the complainant, the agency having custody, control, or use of the building or facility, and the agency funding by contract, grant, or loan, the allegedly non-complying building or facility.

(c) The citation shall contain:

(1) A concise jurisdictional statement reciting the provisions of section 502 of the Rehabilitation Act and Architectural Barriers Act under which the requested action may be taken, (2) a short and plain basis for requesting the imposition of the sanctions, (3) a statement either that within fifteen (15) days a hearing date will be set or that the agency or affected parties may request a hearing within fifteen (15) days from service of the citation, and (4) a list of all pertinent documents necessary for the judge to make a decision on the alleged noncompliance, including but not limited to, contracts, invitations for bids, specifications, contract or grant drawings, and correspondence.

(d) The Executive Director shall file copies of all pertinent documents listed in the citation simultaneously with filing the citation.

**§ 1150.43**

**36 CFR Ch. XI (7-1-03 Edition)**

**§ 1150.43 Answers.**

(a) Answers shall be filed by respondents within fifteen (15) days after receipt of a citation.

(b) The answer shall admit or deny specifically and in detail, matters set forth in each allegation of the citation. If the respondent is without knowledge, the answer shall so state and such statement shall be deemed a denial. Matters not specifically denied shall be deemed admitted. Failure to file a timely answer shall constitute an admission of all facts recited in the citation.

(c) Answers shall contain a list of additional pertinent documents not listed in the citation when respondent reasonably believes these documents are necessary for the judge to make a decision. Copies of the listed documents shall be filed with the answer.

(d) Answers may also contain a request for a hearing under §1150.45.

**§ 1150.44 Amendments.**

(a) The Executive Director may amend the citation as a matter of course before an answer is filed. A respondent may amend its answer once as a matter of course, but not later than five (5) days after the filing of the original answer. Other amendments of the citation or the answer shall be made only by leave of judge.

(b) An amended citation shall be answered within five (5) days of its service, or within the time for filing an answer to the original citation, whichever is longer.

**§ 1150.45 Request for hearing.**

When a citation does not state that a hearing will be scheduled, the respondent, either in a separate paragraph of the answer, or in a separate document, may request a hearing. Failure of a respondent to request a hearing within fifteen (15) days from service of the citation shall be deemed a waiver of the right to a hearing and shall constitute consent to the making of a decision on the basis of available information.

**§ 1150.46 Motions.**

(a) Motions and petitions shall state the relief sought, the authority relied upon, and the facts alleged.

(b) If made before or after the hearing, these matters shall be in writing. If made at the hearing, they may be stated orally or the judge may require that they be reduced to writing and filed and served on all parties.

(c) Except as otherwise ordered by judge, responses to a written motion or petition shall be filed within ten (10) days after the motion or petition is served. An immediate oral response may be made to an oral motion. All oral arguments on motions will be at the discretion of the judge.

(d) A reply to a response may be filed within within five (5) days after the response is served. The reply shall address only the contents of the response.

**§ 1150.47 Disposition of motions and petitions.**

The judge may not sustain or grant a written motion or petition prior to expiration of the time for filing responses, but may overrule or deny such motion or petition without awaiting response, *Providing however*, That pre-hearing conferences, hearings, and decisions need not be delayed pending disposition of motions or petitions. All motions and petitions may be ruled upon immediately after reply. Motions and petitions not disposed of in separate rulings or in decisions will be deemed denied.

**§ 1150.48 PER: Citation, answer, amendment.**

(a) Unless otherwise specified, other relevant sections shall apply to PER proceedings.

(b) In addition to all other forms of relief requested, the citation shall request PER when it appears to the Executive Director that immediate and irreparable harm from noncompliance with the standard is occurring or is about to occur. Citations requesting PER shall recite specific facts and include the affidavit or the notarized complaint upon which the PER request is based. Citations requesting PER shall recite that a hearing regarding PER has been scheduled to take place eight (8) days after receipt of the citation. Citations requesting PER may be filed without prejudice to proceedings in which PER is not requested and

without prejudice to further proceedings if PER is denied. The time and place of hearing fixed in the citation shall be reasonable and shall be subject to change for cause.

(c) Answers to citations requesting PER shall be in the form of all answers, as set forth in §1150.43, and must be filed within four (4) days after receipt of the citation. Answers shall recite in detail, by affidavit or by notarized answer, why the PER requested should not be granted.

(d) When a citation contains both a request for relief to ensure compliance with a standard and a request for PER, an answer to the PER request shall be filed in accordance with paragraph (c) of this section and an answer to a request for other relief shall be filed in accordance with §1150.43.

(e) Citations and answers in PER proceedings may not be amended prior to hearing. Citations and answers in PER proceedings may be amended at the hearing with the permission of the judge.

### Subpart F—Responsibilities and Duties of Judge

#### § 1150.51 Who presides.

(a) A judge assigned to the case under section 3105 or 3344 of title 5 U.S.C. (formerly section 11 of the Administrative Procedure Act), shall preside over the taking of evidence in any hearing to which these rules of procedure apply.

(b) The A&TBCB shall, in writing, promptly notify all parties and participants of the assignment of the judge. This notice may fix the time and place of hearing.

(c) Pending his/her assignment, the responsibilities, duties, and authorities of the judge under these regulations shall be executed by the A&TBCB, through the Chair or another member of the A&TBCB designated by the Chair. A Board member shall not serve in this capacity in any proceeding relating to the member, his/her Federal agency, or organization of which he/she is otherwise interested.

[53 FR 39474, Oct. 7, 1988]

#### § 1150.52 Authority of judge.

The judge shall have the duty to conduct a fair hearing, to take all necessary action to avoid delay, and maintain order. He/she shall have all powers necessary to effect these ends, including (but not limited to) the power to:

(a) Arrange and issue notice of the date, time, and place of hearings previously set.

(b) Hold conferences to settle, simplify, or fix the issues in proceedings, or to consider other matters that may aid in the expeditious disposition of the proceedings.

(c) Require parties and participants to state their position with respect to the various issues in the proceedings.

(d) Administer oaths and affirmations.

(e) Rule on motions, and other procedural items on matters pending before him/her.

(f) Regulate the course of the hearing and conduct of counsel.

(g) Examine witnesses and direct witnesses to testify.

(h) Receive, rule on, exclude or limit evidence.

(i) Fix time for filing motions, petitions, briefs, or other items in matters pending before him/her.

(j) Issue decisions.

(k) Take any action authorized by the rules in this part or the provisions of sections 551 through 559 of title 5 U.S.C. (the Administrative Procedure Act).

[45 FR 78474, Nov. 25, 1980. Redesignated at 53 FR 39474, Oct. 7, 1988]

#### § 1150.53 Disqualification of judge.

(a) A judge shall disqualify himself/herself whenever in his/her opinion it is improper for him/her to preside at the proceedings.

(b) At any time following appointment of the judge and before the filing of the decision, any party may request the judge to withdraw on grounds of personal bias or prejudice either against it or in favor of any adverse party, by promptly filing with him/her an affidavit setting forth in detail the alleged grounds for disqualification.

(c) If, in the opinion of the judge, the affidavit referred to in paragraph (b) of this section is filed with due diligence

## § 1150.61

and is sufficient on its face, the judge shall promptly disqualify himself/herself.

(d) If the judge does not disqualify himself/herself, he/she shall so rule upon the record, stating the grounds for his/her ruling. Then, he/she shall proceed with the hearing, or, if the hearing has closed, he/she shall proceed with the issuance of the decision.

[45 FR 78474, Nov. 25, 1980. Redesignated at 53 FR 39474, Oct. 7, 1988]

### Subpart G—Prehearing Conferences and Discovery

#### § 1150.61 Prehearing conference.

(a) At any time before a hearing, the judge on his/her own motion or on motion of a party, may direct the parties or their representative to exchange information or to participate in a prehearing conference for the purpose of considering matters which tend to simplify the issues or expedite the proceedings.

(b) The judge may issue a prehearing order which includes the agreements reached by the parties. Such order shall be served upon all parties and participants and shall be a part of the record.

#### § 1150.62 Exhibits.

(a) Proposed exhibits shall be exchanged at the prehearing conference, or otherwise prior to the hearing if the judge so requires. Proposed exhibits not so exchanged may be denied admission as evidence.

(b) The authenticity of all proposed exhibits will be deemed admitted unless written objection to them is filed prior to the hearing or unless good cause is shown at the hearing for failure to file such written objection.

#### § 1150.63 Discovery.

(a) Parties are encouraged to engage in voluntary discovery procedures. For good cause shown under appropriate circumstances, but not as a matter of course, the judge may entertain motions for permission for discovery and issue orders including orders—(1) to submit testimony upon oral examination or written interrogatories before an officer authorized to administer

## 36 CFR Ch. XI (7–1–03 Edition)

oaths, (2) to permit service of written interrogatories upon the opposing party, (3) to produce and permit inspection of designated documents, and (4) to permit service upon the opposing parties of a request for the admission of specified facts.

(b) Motions for discovery shall be granted only to the extent and upon such terms as the judge in his/her discretion considers to be consistent with and essential to the objective of securing a just and inexpensive determination of the merits of the citation without unnecessary delay.

(c) In connection with any discovery procedure, the judge may make any order which justice requires to protect a party or person from annoyance, embarrassment, oppression or undue burden or expense, including limitations on the scope, method, time and place for discovery, and provisions for protecting the secrecy of confidential information or documents. If any party fails to comply with a discovery order of the judge, without an excuse or explanation satisfactory to the judge, the judge may decide the fact or issue relating to the material requested to be produced, or the subject matter of the probable testimony, in accordance with claims of the other party in interest or in accordance with the other evidence available to the judge, or make such other ruling as he/she determines just and proper.

### Subpart H—Hearing Procedures

#### § 1150.71 Briefs.

The judge may require parties and participants to file written statements of position before the hearing begins. The judge may also require the parties to submit trial briefs.

#### § 1150.72 Purpose of hearing.

Hearings for the receipt of evidence will be held only in cases where issues of fact must be resolved. Where it appears from the citation, the answer, stipulations, or other documents in the record, that there are no matters of material fact in dispute, the judge may enter an order so finding, vacating the hearing date, if one has been set, and fixing the time for filing briefs.



**§ 1150.73 Testimony.**

(a) Formal rules of evidence shall not apply, but rules or principles designed to assure production of the most probative evidence available do apply. Testimony shall be given orally under oath or affirmation; but the judge, in his/her discretion, may require or permit the direct testimony of any witness to be prepared in writing and served on all parties in advance of the hearing. Such testimony may be adopted by the witness at the hearing and filed as part of the record.

(b) All witnesses shall be available for cross-examination and, at the discretion of the judge, may be cross-examined without regard to the scope of direct examination as to any matter which is relevant and material to the proceeding.

(c) When testimony is taken by deposition, an opportunity shall be given, with appropriate notice, for all parties to cross-examine the witness. Objections to any testimony or evidence presented shall be deemed waived unless raised at the time of the deposition.

(d) Witnesses appearing before the judge shall be paid the same fees and mileage that are paid witnesses in the courts of the United States. Witnesses whose depositions are taken and the persons taking the same shall be entitled to the same fees as are paid for like services in the courts of the United States. Witness fees and mileage shall be paid by the party requesting the witness to appear, and the person taking a deposition shall be paid by the party requesting the taking of the deposition.

**§ 1150.74 Exclusion of evidence.**

The judge may exclude evidence which is immaterial, irrelevant, unreliable, or unduly repetitious.

**§ 1150.75 Objections.**

Objections to evidence or testimony shall be timely and may briefly state the grounds.

**§ 1150.76 Exceptions.**

Exceptions to rulings of the judge are unnecessary. It is sufficient that a party at the time the ruling of the judge is sought, makes known the ac-

tion which he/she desires the judge to take, or his/her objection to an action taken, and his/her grounds for it.

**§ 1150.77 Official notice.**

Where official notice is taken or is to be taken of a material fact not appearing in the evidence of record, any party on timely request, shall be afforded an opportunity to question the propriety of taking notice or to rebut the fact noticed.

**§ 1150.78 Public documents.**

When a party or participant offers, in whole or in part, a public document, such as an official report, decision, opinion, or published scientific or economic statistical data issued by any of the executive departments, or their subdivisions, legislative agencies or committees or administrative agencies of the Federal government (including government-owned corporations), or a similar document issued by a State or local government or their agencies, and such document (or part thereof) has been shown by the offeror to be reasonably available to the public, such document need not be produced or marked for identification, but may be offered for official notice, as a public document by specifying the document or its relevant part.

**§ 1150.79 Offer of proof.**

An offer of proof made in connection with an objection taken to a ruling of the judge rejecting or excluding proffered oral testimony shall consist of a statement of the substance of the evidence which counsel contends would be adduced by such testimony. If the excluded evidence consists of evidence in documentary or written form or refers to documents or records, a copy of the evidence shall be marked for identification and shall accompany the record as the offer of proof.

**§ 1150.80 Affidavits.**

An affidavit is not inadmissible as such. Unless the judge fixes other time periods, affidavits shall be filed and served on the parties not later than fifteen (15) days prior to the hearing. Not less than seven (7) days prior to hearing, a party may file and serve written objections to any affidavit on the

## § 1150.81

ground that he/she believes it necessary to test the truth of its assertions at hearing. In such event the assertions objected to will not be received in evidence unless the affiant is made available for cross-examination, or the judge determines that cross-examination is not necessary for the full and true disclosure of facts referred to in such assertions. Notwithstanding any objection, however, affidavits may be considered in the case of any respondent who waives a hearing.

### § 1150.81 Consolidated or joint hearing.

In cases in which the same or related facts are asserted to constitute non-compliance with standards or guidelines and requirements, the judge may order all related cases consolidated and may make other orders concerning the proceedings as will be consistent with the objective of securing a just and inexpensive determination of the case without unnecessary delay.

### § 1150.82 PER proceedings.

(a) In proceedings in which a citation, or part of one, seeking PER has been filed, the judge shall make necessary rulings with respect to time for filing of pleadings, the conduct of the hearing, and to all other matters. He/she shall do all other things necessary to complete the proceeding in the minimum time consistent with the objective of securing an expeditious, just and inexpensive determination of the case. The times for actions set forth in these rules shall be followed unless otherwise ordered by the judge.

(b) The judge shall determine the terms and conditions for orders of PER. These orders must be consistent with preserving the rights of all parties so as to permit the timely processing of the citation, or part of it, not requesting PER, as well as consistent with the provisions and objectives of the Architectural Barriers Act and section 502 of the Rehabilitation Act. In issuing an order for PER, the judge shall make the following specific findings of fact and conclusions of law—

(1) The Executive Director is likely to succeed on the merits of the proceedings;

## 36 CFR Ch. XI (7–1–03 Edition)

(2) The threatened injury or violation outweighs the threatened harm to the respondent if PER is granted; and

(3) Granting PER is in the public interest.

(c) The judge may dismiss any citation or part of a citation seeking PER when the judge finds that the timely processing of a citation not requesting PER will adequately ensure the objectives of section 502 of the Rehabilitation Act and that immediate and irreparable harm caused by noncompliance with the standards or guidelines and requirements is not occurring or about to occur.

## Subpart I—The Record

### § 1150.91 Record for decision.

The transcript of testimony, exhibits and all papers, documents and requests filed in the proceeding, including briefs and proposed findings and conclusions, shall constitute the record for decision.

### § 1150.92 Official transcript.

The official transcripts of testimony, and any exhibits, briefs, or memoranda of law filed with them, shall be filed with the judge. Transcripts of testimony in hearings may be obtained from the official reporter by the parties and the public at rates not to exceed the maximum rates fixed by the contract between the A&TBCB and the reporter. Upon notice to all parties, the judge may authorize corrections to the transcript as are necessary to reflect accurately the testimony.

## Subpart J—Posthearing Procedures; Decisions

### § 1150.101 Posthearing briefs; proposed findings.

The judge shall fix the terms, including time, for filing post-hearing statements of position or briefs, which may contain proposed findings of fact and conclusions of law. The judge may fix a reasonable time for such filing, but this period shall not exceed thirty (30) days from the receipt by the parties of the transcript of the hearing.

**§ 1150.102 Decision.**

(a) The judge shall issue a decision within thirty (30) days after the hearing ends or, when the parties submit posthearing briefs, within thirty (30) days after the filing of the briefs.

(b) The decision shall contain (1) all findings of fact and conclusions of law regarding all material issues of fact and law presented in the record, (2) the reasons for each finding of fact and conclusion of law, and (3) other provisions which effectuate the purposes of the Architectural Barriers Act and section 502 of the Rehabilitation Act. The decision may direct the parties to take specific action or may order the suspension or withholding of Federal funds.

(c) The decision shall be served on all parties and participants to the proceedings.

**§ 1150.103 PER: Posthearing briefs, decision.**

(a) No briefs or posthearing statements of position shall be required in proceedings seeking PER unless specifically ordered by the judge.

(b) In proceedings seeking PER the decision may be given orally at the close of the hearing and shall be made in writing within three (3) days after the hearing.

**§ 1150.104 Judicial review.**

Any complainant or participant in a proceeding may obtain judicial review of a final order issued in a compliance proceeding.

**§ 1150.105 Court enforcement.**

The Executive Director, at the direction of the Board, shall bring a civil action in any appropriate United States district court to enforce, in whole or in part, any final compliance order. No member of the A&TBCB shall participate in any decision of the A&TBCB concerning a proceeding relating to the member, his/her Federal agency, or organization to which he/she is a member or in which he/she is otherwise interested.

**Subpart K—Miscellaneous Provisions****§ 1150.111 Ex parte communications.**

(a) No party, participant or other person having an interest in the case shall make or cause to be made an ex parte communication to the judge with respect to the case.

(b) A request for information directed to the judge which merely inquires about the status of a proceeding without discussing issues or expressing points of view is not deemed an ex parte communication. Communications with respect to minor procedural matters or inquires or emergency requests for extensions of time are not deemed ex parte communications prohibited by paragraph (a) of this section. Where feasible, however, such communications should be by letter, with copies delivered to all parties. Ex parte communications between a party or participant and the Executive Director with respect to securing compliance are not prohibited.

(c) In the event an ex parte communication occurs, the judge shall issue orders and take action as fairness requires. A prohibited communication in writing received by the judge shall be made public by placing it in the correspondence file of the docket in the case and will not be considered as part of the record for decision. If the prohibited communication is received orally, a memorandum setting forth its substance shall be made and filed in the correspondence section of the docket in the case. A person referred to in this memorandum may file a comment for inclusion in the docket if he/she considers the memorandum to be incorrect.

**§ 1150.112 Post-order proceedings.**

(a) Any party adversely affected by the compliance order issued by a judge may make a motion to the judge to have such order vacated upon a showing that the building or facility complies with the order.

(b) Notice of motions and copies of all pleadings shall be served on all parties and participants to the original proceeding. Responses to the motion to

## § 1150.113

vacate shall be filed within ten (10) days after receipt of the motion unless the judge for good cause shown grants additional time to respond.

(c) Oral arguments on the motion may be ordered by the judge. The judge shall fix the terms of the argument so that they are consistent with the objective of securing a prompt, just, and inexpensive determination of the motion.

(d) Within ten (10) days after receipt of all answers to the motion, the judge shall issue his/her decision in accordance with § 1150.102 (b) and (c).

### § 1150.113 Amicable resolution.

(a) Amicable resolution is encouraged at any stage of proceedings where such resolution is consistent with the provisions and objectives of the Architectural Barriers Act and section 502 of the Rehabilitation Act.

(b) Agreements to amicably resolve pending proceedings shall be submitted by the parties and shall be accompanied by an appropriate proposed order.

(c) The Executive Director is authorized to resolve any proceeding on behalf of the A&TBCB unless otherwise specifically directed by the A&TBCB and afterwards may file appropriate stipulations or notice that the proceeding is discontinued.

### § 1150.114 Effect of partial invalidity.

If any section, subsection, paragraph, sentence, clause or phrase of these regulations is declared invalid for any reason, the remaining portions of these regulations that are severable from the invalid part shall remain in full force and effect. If a part of these regulations is invalid in one or more of its applications, the part shall remain in effect in all valid applications that are severable from the invalid applications.

## PART 1151—BYLAWS

Sec.	
1151.1	Establishment.
1151.2	Authority.
1151.3	Officers.
1151.4	Delegations.
1151.5	Board meetings.
1151.6	Committees.
1151.7	Amendments to the bylaws.

## 36 CFR Ch. XI (7–1–03 Edition)

AUTHORITY: 29 U.S.C. 792.

SOURCE: 63 FR 1924, Jan. 13, 1998, unless otherwise noted.

### § 1151.1 Establishment.

The Architectural and Transportation Barriers Compliance Board was established pursuant to section 502 of the Rehabilitation Act of 1973, as amended. The agency is also known and often referred to as the “Access Board” or simply the “Board.”

### § 1151.2 Authority.

The Board shall have the authority and responsibilities as set forth in section 502 of the Rehabilitation Act of 1973 (29 U.S.C. 792); section 504 of the Americans with Disabilities Act of 1990 (42 U.S.C. 12204); and section 225(e) of the Telecommunications Act of 1996 (47 U.S.C. 255(e)).

### § 1151.3 Officers.

(a) *Board.* The Board is the governing body of the agency.

(b) *Chair, Vice-Chair.* The head of the agency is the Chair of the Board and, in his or her absence or disqualification, the Vice-Chair of the Board. As head of the agency, the Chair represents the Board whenever an applicable Federal statute or regulation imposes a duty or grants a right or authority to the head of the agency and has the authority to act in all matters relating to the operation of the Board. The Chair may delegate any such duties and responsibilities by written delegation of authority. The Chair supervises the Executive Director and evaluates his or her performance and approves performance evaluations of employees who report directly to the Executive Director. The authority to supervise, evaluate and approve performance evaluations of the Executive Director and those employees who report directly to the Executive Director may only be delegated to the Vice-Chair of the Board.

(c) *Election, term.* The Chair and the Vice-Chair of the Board shall be elected by a majority of the membership of the Board (as fixed by statute) and serve for terms of one year. Elections shall be held as soon as possible upon completion of the one year term of the Chair and Vice-Chair. If no new Chair

or Vice-Chair has been elected at the end of the one-year term, the incumbents shall continue to serve in that capacity until a successor Chair or Vice-Chair has been elected. When the Chair is a public member, the Vice-Chair shall be a Federal member; and when the Chair is a Federal member, the Vice-Chair shall be a public member. Upon the expiration of the term as Chair of a Federal member, the subsequent Chair shall be a public member; and vice versa.

(d) *Executive Director.* The Executive Director is nominated by the Chair and confirmed by the Board. The Executive Director provides administrative leadership, and supervision and management of staff activities in carrying out the policies and decisions of the Board under the direction and supervision of the Chair. The Executive Director has the authority to execute contracts, agreements and other documents necessary for the operation of the Board; hire, fire and promote staff (including temporary or intermittent experts and consultants); procure space, equipment and supplies; and obtain interagency and commercial support services. The Executive Director directs compliance and enforcement activities in accordance with the procedures set forth in 36 CFR part 1150, including issuing citations and determinations not to proceed, conducting negotiations for compliance, entering into agreements for voluntary compliance and performing all other actions authorized by law pertaining to compliance and enforcement not otherwise reserved to the Board.

(e) *General Counsel.* The General Counsel is nominated by the Chair and confirmed by the Board. The General Counsel is responsible to the Board under the supervision of the Executive Director.

#### § 1151.4 Delegations.

(a) *Executive Committee.* The Board may delegate to the Executive Committee authority to implement its decisions by a majority vote of the members present at a meeting and any proxies. To the extent permitted by law, the Board may delegate to the Executive Committee any other of its authorities by two-thirds vote of the members present at a meeting and any

proxies. A separate delegation is necessary for each action the Board desires the Executive Committee to implement.

(b) *Other.* To the extent permitted by law, the Board may delegate other duties to its officers or committees by a vote of two-thirds of the members present at a meeting and any proxies.

(c) *Redelegation.* Unless expressly prohibited in the original delegation, an officer or committee may redelegate authority.

#### § 1151.5 Board meetings.

(a) *Number.* The Chair shall schedule five regular meetings of the Board each year. In addition, the Board shall schedule one Board sponsored public event.

(b) *Timing.* Regular meetings of the Board and at least one Board sponsored event shall ordinarily be held on the Wednesday following the second Tuesday of every other month. The Chair may reschedule a regular meeting of the Board to another date, no more than one month earlier or later than the regularly scheduled date.

(c) *Agenda.* The Chair establishes the agenda for the meetings. Members or committees shall forward submissions for agenda items to the Chair. Except for items concerning the adoption, amendment or rescision of the bylaws in this part, an item may be placed before the Board for consideration without the approval of the Chair upon a two-thirds vote of the members present at a Board meeting and any proxies to suspend the rules of order. Items concerning the adoption, amendment or rescision of the bylaws in this part may be placed on a future Board agenda without the approval of the Chair upon a vote of two-thirds of the membership of the Board (as fixed by statute).

(d) *Notice.* The Chair shall provide a written notice of scheduled Board meetings, including the agenda and supporting materials for the meeting, to each Board member at least ten (10) work days prior to the meeting. The ten (10) days notice requirement may be waived upon a two-thirds vote by the members present at the Board meeting and any proxies to suspend the rules of order.

## § 1151.6

(e) *Cancellation.* The Chair may cancel a regular meeting of the Board by giving written notice of the cancellation at least ten (10) work days prior to the meeting where practical.

(f) *Special meetings.* The Chair may call special meetings of the Board to deal with important matters arising between regular meetings which require action by the Board prior to the next regular meeting. Voting and discussion shall be limited to the subject matter which necessitated the call of the special meeting. All Board members shall receive reasonable advance notice of the time, place, and purpose of the special meeting.

(g) *Record.* The Executive Director shall maintain a permanent record of the minutes of the meeting and attendance. The Board shall approve the final minutes after all corrections and additions have been incorporated.

(h) *Rules for Board meetings.* Meetings of the Board shall be held in accordance with Robert's Rules of Order, except as otherwise prescribed in the bylaws in this part.

(i) *Quorum.* (1) A quorum shall be the majority of the membership of the Board (as fixed by statute). At least half of the members required for a quorum shall be public members.

(2) Proxies shall not be counted for purposes of establishing a quorum.

(3) If a quorum is not present, a meeting shall be held only for the purpose of discussion and no vote may be taken.

(j) *Voting.* (1) Only Board members may vote.

(2) Except as otherwise prescribed in the bylaws in this part, a majority vote of the members present and any proxies is necessary for action by the Board.

(3) The presiding officer shall have the same right to vote as any other member.

(4) Any member may give his or her directed or undirected proxy to any other Board member, present at the meeting. Proxies shall be given in writing and submitted to the Chair prior to or at the meeting. A directed proxy shall be voided as to a specific issue if the question on which the vote is eventually taken differs from the question to which the proxy is directed.

## 36 CFR Ch. XI (7-1-03 Edition)

(5) The Board may act on items of business between meetings by notational voting. At the request of the Chair, the Executive Director shall send a written ballot to each Board member describing each item submitted for notational voting. If any Board member requests discussion on an item, the ballots shall not be counted and the Chair shall place the item on the next Board meeting agenda for discussion and voting.

(k) *Telecommunications.* A member of the Board shall be considered present at a meeting when he or she participates in person or by conference telephone or similar communication equipment which enables all persons participating in the meeting to communicate with each other.

### § 1151.6 Committees.

(a) *Executive Committee*—(1) *Establishment.* The Board shall have an Executive Committee to serve as a leadership and coordinating committee. The Executive Committee acts on behalf of the Board in between regularly scheduled Board meetings as necessary and as authorized by delegation of the Board. In addition, the Executive Committee has the following duties and responsibilities:

(i) To review and consider recommendations and proposals from the various subject matter committees;

(ii) To review and make recommendations to the Board to amend or approve the Board's bylaws; and

(iii) To request and review all committee charters.

(2) *Chair.* The Vice-Chair of the Board shall serve as Chair of the Executive Committee.

(3) *Membership.* The Executive Committee shall be composed of a minimum of six members, three Federal and three public members, which shall include the Chair and the Vice-Chair of the Board, the chairs of each of the subject matter committees, and two at large members. The two at large members shall balance the number of Federal and public members and shall be elected by the Board after the election of the Chair and Vice-Chair of the Board and the chairs of the subject matter committees. In the event that the Board should establish three or

more subject matter committees, additional at-large members shall be elected as necessary to balance the Federal and public membership of the committee.

(4) *Quorum.* A quorum in the Executive Committee shall be a majority of the membership, present at the meeting. In the absence of their Federal member, the liaison may count toward a quorum. If a quorum is not present, a meeting can be held only for the purpose of discussion and no vote may be taken.

(5) *Voting.* (i) The presiding officer shall have the same right to vote as any other member.

(ii) On matters subject to Board review, liaisons are permitted to vote in the absence of their Federal member. A majority vote of the members (or liaisons) present at the meeting and any directed or undirected proxies is necessary for action by the committee.

(iii) On matters of final action, not subject to Board review, a majority vote of the membership of the committee, present at the meeting or by directed proxy, is necessary for action by the committee. In the absence of their Federal member, liaisons are permitted to cast a directed proxy only.

(b) *Subject matter committees—(1) Establishment.* The Board may establish or dissolve subject matter committees by a two-thirds vote of the members present and any proxies.

(2) *Chair.* The Chair of a subject matter committee shall be elected by the Board after the election of the Chair and Vice-Chair of the Board and shall serve as a member of the Board's Executive Committee.

(3) *Membership.* Each subject matter committee shall be comprised of a minimum of seven, and a maximum of nine, members. Except for the Chair of the committee who is elected by the Board, the members of the committee shall be appointed by the Chair of the Board. Members shall serve a term of one year corresponding to that of the Chair of the Board, and continue their duties until their successors have been appointed.

(4) *Quorum.* A quorum shall be a majority of the actual membership of the committee. A liaison may represent the Federal member for purposes of a

quorum. If a quorum is not present, a meeting shall be held only for the purpose of discussion and no vote may be taken.

(5) *Voting.* Directed or undirected proxies are permitted. In the absence of their Federal member, liaisons are permitted to vote on all matters which are subject to review by the full Board. The presiding officer shall have the same right to vote as any other member. A majority vote of the members (or liaisons) present at the meeting and any directed or undirected proxies is necessary for action by the committee.

(c) *Special committees.* The Chair, the Board, the Executive Committee or a subject matter committee may appoint a special committee to carry out a specific task. A special committee shall dissolve upon completion of its task or when dissolved by its creator. A special committee shall be governed by the same rules and procedures applicable to subject matter committees unless other rules or procedures are approved by the creator of the committee.

(d) *Telecommunications.* A member of a committee shall be considered present at a meeting when he or she participates in person or by conference telephone or similar communication equipment which enables all persons participating in the meeting to communicate with each other.

(e) *Charter.* With the exception of a Committee of the Whole, each committee shall establish a charter and may establish any additional procedures provided that they do not conflict with the provisions of the bylaws in this part.

(f) *Procedure.* Committee meetings shall be held in accordance with Robert's Rules of Order, except as otherwise prescribed in the bylaws in this part or committee charters.

(g) *Records.* Committees shall maintain written records of the meetings.

#### § 1151.7 Amendments to the bylaws.

In order to amend the bylaws in this part, a vote of two-thirds of the membership of the Board (as fixed by statute) at the time the vote is taken shall be required. The Board shall not suspend the rules in taking any action concerning adoption, amendment or revision of the bylaws in this part except

that by vote of two-thirds of the membership of the Board (as fixed by statute), an item concerning the adoption, amendment or rescision of the bylaws in this part may be placed on an agenda for Board consideration at a future meeting.

**PART 1154—ENFORCEMENT OF NONDISCRIMINATION ON THE BASIS OF HANDICAP IN PROGRAMS OR ACTIVITIES CONDUCTED BY THE ARCHITECTURAL AND TRANSPORTATION BARRIERS COMPLIANCE BOARD**

Sec.

- 1154.101 Purpose.
- 1154.102 Application.
- 1154.103 Definitions.
- 1154.104–1154.109 [Reserved]
- 1154.110 Self-evaluation.
- 1154.111 Notice.
- 1154.112–1154.129 [Reserved]
- 1154.130 General prohibitions against discrimination.
- 1154.131–1154.139 [Reserved]
- 1154.140 Employment.
- 1154.141–1154.148 [Reserved]
- 1154.149 Program accessibility: Discrimination prohibited.
- 1154.150 Program accessibility: Existing facilities.
- 1154.151 Program accessibility: New construction and alterations.
- 1154.152–1154.159 [Reserved]
- 1154.160 Communications.
- 1154.161–1154.169 [Reserved]
- 1154.170 Compliance procedures.

AUTHORITY: 29 U.S.C. 794.

SOURCE: 52 FR 16380, May 5, 1987, unless otherwise noted.

**§ 1154.101 Purpose.**

The purpose of this part is to effectuate section 119 of the Rehabilitation, Comprehensive Service, and Developmental Disabilities Amendments of 1978, which amended section 504 of the Rehabilitation Act of 1973 to prohibit discrimination on the basis of handicap in programs or activities conducted by Executive agencies or the United States Postal Service.

**§ 1154.102 Application.**

This part applies to all programs or activities conducted by the agency.

**§ 1154.103 Definitions.**

For purposes of this part, the term—  
*Agency* means the Architectural and Transportation Barriers Compliance Board.

*Assistant Attorney General* means the Assistant Attorney General, Civil Rights Division, United States Department of Justice.

*Auxiliary aids* means service or devices that enable persons with impaired sensory, manual, and/or speaking skills to have an equal opportunity to participate in, and enjoy the benefits of, programs or activities conducted by the agency. For example, auxiliary aids useful for persons with impaired vision include readers, Brailled materials, audio recordings, telecommunications devices and other similar services and devices. Auxiliary aids useful for persons with impaired hearing include telephones handset amplifiers, telephone compatible with hearing aids, telecommunication devices for deaf persons (TDD's), interpreters, notetakers, written materials, and other similar services and devices.

*Complete complaint* means a written statement that contains the complainant's name and address and describes the agency's alleged discriminatory action in sufficient detail to inform the agency of the nature and date of the alleged violation of section 504. It shall be signed by the complainant or by someone authorized to do so on his or her behalf. Complaints filed on behalf of classes or third parties shall describe or identify (by name, if possible) the alleged victims of discriminations.

*Facility* means all or any portion of buildings, structures, equipment, roads, walks, parking lots, rolling stock or other conveyances, or other real or personal property.

*Handicapped person* means any person who has a physical or mental impairment that substantially limits one or more major life activities, has a record of such an impairment, or is regarded as having such an impairment.

As used in this definition, the phrase:

(1) *Physical or mental impairment* includes—

(i) Any physiological disorder or condition, cosmetic disfigurement, or anatomical loss affecting one or more of



the following body systems: neurological; musculoskeletal; special sense organs; respiratory, including speech organs; cardiovascular; reproductive; digestive; genitourinary; hemic and lymphatic; skin; and endocrine; or

(ii) Any mental or psychological disorder, such as mental retardation, organic brain syndrome, emotional or mental illness, and specific learning disabilities. The term *physical or mental impairment* includes, but is not limited to, such diseases and conditions as orthopedic, visual, speech, and hearing impairments, cerebral palsy, epilepsy, muscular dystrophy, multiple sclerosis, cancer, heart disease, diabetes, mental retardation, emotional illness, and drug addiction and alcoholism.

(2) *Major life activities* includes functions such as caring for one's self, performing manual tasks, walking, seeing, hearing, speaking breathing, learning, and working.

(3) *Has a record of such an impairment* means has a history of, or has been misclassified as having, a mental or physical impairment that substantially limits one or more major life activities.

(4) *Is regarded as having an impairment* means—

(i) Has a physical or mental impairment that does not substantially limit major life activities but is treated by the agency as constituting such a limitation;

(ii) Has a physical or mental impairment that substantially limits major life activities only as a result of the attitudes of others toward such impairment; or

(iii) Has none of the impairments defined in subparagraph (1) of this definition but is treated by the agency as having such an impairment.

*Qualified handicapped person* means—

(1) With respect to any agency program or activity under which a person is required to perform services or to achieve a level of accomplishment, a handicapped person who meets the essential eligibility requirements and who can achieve the purpose of the program or activity without modifications in the program or activity that the agency can demonstrate would result in a fundamental alteration in its nature; and

(2) With respect to any other program or activity, a handicapped person who meets the essential eligibility requirements for participation in, or receipt of benefits from, that program or activity.

(3) *Qualified Handicapped Person* is defined for purposes of employment in 29 CFR 1613.702(f) which is made applicable to this part by § 1154.140.

*Section 504* means section 504 of the Rehabilitation Act of 1973 (Pub. L. 93-112, 87 Stat. 394 (29 U.S.C. 794)), as amended by the Rehabilitation Act Amendments of 1974 (Pub. L. 93-516, 88 Stat. 1617), and the Rehabilitation, Comprehensive Services, and Developmental Disabilities Amendments of 1978 (Pub. L. 95-602, 92 Stat. 2955). As used in this part, section 504 applies only to programs or activities conducted by Executive agencies and not to federally assisted programs.

#### §§ 1154.104–1154.109 [Reserved]

#### § 1154.110 Self-evaluation.

(a) By July 6, 1988, the agency shall evaluate its current policies and practices, and the effects thereof, that do not or may not meet the requirements of this part, and, to the extent modification of any such policies and practices is required, the agency shall proceed to make the necessary modifications.

(b) The agency shall provide an opportunity to interested persons, including handicapped persons or organizations representing handicapped persons, to participate in the self-evaluation process by submitting comments (both oral and written).

(c) The agency shall, for all least three years following completion of the evaluation required under paragraph (a) of this section, maintain on file and make available for public inspection—

(1) A description of areas examined and any problems identified; and

(2) A description of any modifications made.

#### § 1154.111 Notice.

The agency shall make available to employees, applicants, participants, beneficiaries, and other interested persons such information regarding the

**§§ 1154.112–1154.129**

**36 CFR Ch. XI (7–1–03 Edition)**

provisions of this part and its applicability to the programs or activities conducted by the agency, and made such information available to them in such manner as the agency head finds necessary to apprise effectively such persons of the protections against discrimination assured them by section 504 and this regulation.

**§§ 1154.112–1154.129 [Reserved]**

**§ 1154.130 General prohibitions against discrimination.**

(a) No qualified handicapped person shall, on the basis of handicap, be excluded from participation in, be denied the benefits of, or otherwise be subjected to discrimination under any program or activity conducted by the agency.

(b)(1) The agency, in providing any aid, benefit, or service, may not, directly or through contractual, licensing, or other arrangements, on the basis of handicap—

(i) Deny a qualified handicapped person the opportunity to participate in or benefit from the aid, benefit, or service;

(ii) Afford a qualified handicapped person an opportunity to participate in or benefit from the aid, benefit, or service that is not equal to that afforded others;

(iii) Provide a qualified handicapped person with an aid, benefit, or service that is not as effective in affording equal opportunity to obtain the same result, to gain the same benefit, or to reach the same level of achievement as that provided to others;

(iv) Provide different or separate aid, benefits, or services to handicapped persons or to any class of handicapped persons than is provided to others unless such action is necessary to provide qualified handicapped persons with aid, benefits, or services that are as effective as those provided to others;

(v) Deny a qualified handicapped person the opportunity to participate as a member of planning or advisory boards; or

(vi) Otherwise limit a qualified handicapped person in the enjoyment of any right, privilege, advantage, or opportunity enjoyed by others receiving the aid, benefit, or service.

(2) The agency may not deny a qualified handicapped person the opportunity to participate in programs or activities that are not separate or different, despite the existence of permissibly separate or different programs or activities.

(3) The agency may not, directly or through contractual or other arrangements, utilize criteria or methods of administration the purpose or effect of which would—

(i) Subject qualified handicapped persons to discrimination on the basis of handicap; or

(ii) Defeat or substantially impair accomplishment of the objectives of a program or activity with respect to handicapped persons.

(4) The agency may not, in determining the site or location of a facility, make selections the purpose or effect of which would—

(i) Exclude handicapped persons from, deny them the benefits of, or otherwise subject them to discrimination under any program or activity conducted by the agency; or

(ii) Defeat or substantially impair the accomplishment of the objectives of a program or activity with respect to handicapped persons.

(5) The agency, in the selection of procurement contractors, may not use criteria that subject qualified handicapped persons to discrimination on the basis of handicap.

(c) The exclusion of nonhandicapped persons from the benefits of a program limited by Federal statute or Executive order to handicapped persons or the exclusion of a specific class of handicapped persons from a program limited by Federal statute or Executive order to a different class of handicapped persons is not prohibited by this part.

(d) The agency shall administer programs and activities in the most integrated setting appropriate to the needs of qualified handicapped persons.

**§§ 1154.131–1154.139 [Reserved]**

**§ 1154.140 Employment.**

No qualified handicapped person shall, on the basis of handicap, be subjected to discrimination in employment under any program or activity

conducted by the agency. The definitions, requirements, and procedures of section 501 of the Rehabilitation Act of 1973 (29 U.S.C. 791), as established by the Equal Employment Opportunity Commission in 29 CFR part 1613, shall apply to employment in federally-conducted programs or activities.

**§§ 1154.141-1154.148 [Reserved]**

**§ 1154.149 Program accessibility: Discrimination prohibited.**

Except as otherwise provided in § 1154.150, no qualified handicapped person shall, because the agency's facilities are inaccessible to or unusable by handicapped persons, be denied the benefits of, be excluded from participation in, or otherwise be subjected to discrimination under any program or activity conducted by the agency.

**§ 1154.150 Program accessibility: Existing facilities.**

(a) *General.* The agency shall operate each program or activity so that the program or activity, when viewed in its entirety, is readily accessible to and usable by handicapped persons. This paragraph does not—

(1) Necessarily require the agency to make each of its existing facilities accessible to and usable by handicapped persons; or

(2) Require the agency to take any action that it can demonstrate would result in a fundamental alteration in the nature of a program or activity or in undue financial and administrative burdens. In those circumstances where agency personnel believe that the proposed action would fundamentally alter the program or activity or would result in undue financial and administrative burdens, the agency has the burden of proving that compliance with § 1154.150(a) would result in such alteration or burdens. The decision that compliance would result in such alteration or burdens must be made by the agency head or his/her designee after considering all agency resources available for use in the funding and operation of the conducted program or activity, and must be accompanied by a written statement of the reasons for reaching that conclusion. If an action would result in such an alteration or

such burdens, the agency shall take any other action that would not result in such an alteration or such burdens but would nevertheless ensure that handicapped persons receive the benefits and services of the program or activity.

(b) *Methods.* The agency may comply with the requirements of this section through such means as redesign of equipment, reassignment of services to accessible buildings, assignment of aides to beneficiaries, home visits, delivery of services at alternate accessible sites, alteration of existing facilities and construction of new facilities, use of accessible rolling stock, or any other methods that result in making its programs or activities readily accessible to and usable by handicapped persons. The agency is not required to make structural changes in existing facilities where other methods are effective in achieving compliance with this section. The agency, in making alterations to existing buildings, shall meet accessibility requirements to the extent compelled by the Architectural Barriers Act of 1968, as amended (42 U.S.C. 4151-4157), and any regulations implementing it. In choosing among available methods for meeting the requirements of this section, the agency shall give priority to those methods that offer programs and activities to qualified handicapped persons in the most integrated setting appropriate.

(c) *Time period for compliance.* The agency shall comply with the obligations established under this section by September 4, 1987 except that where structural changes in facilities are undertaken, such changes shall be made by July 6, 1990, but in any event as expeditiously as possible.

(d) *Transition plan.* In the event that structural changes to facilities will be undertaken to achieve program accessibility, the agency shall develop by January 6, 1988, a transition plan setting forth the steps necessary to complete such changes. The agency shall provide an opportunity to interested persons, including handicapped persons or organizations representing handicapped persons, to participate in the development of the transition plan by submitting comments (both oral and written). A copy of the transition plan

**§ 1154.151**

shall be made available for public inspection. The plan shall, at a minimum—

(1) Identify physical obstacles in the agency's facilities that limit the accessibility of its programs or activities to handicapped persons;

(2) Describe in detail the methods that will be used to make the facilities accessible;

(3) Specify the schedule for taking the steps necessary to achieve compliance with this section and, if the time period of the transition plan is longer than one year, identify steps that will be taken during each year of the transition period; and

(4) Indicate the official responsible for implementation of the plan.

**§ 1154.151 Program accessibility: New construction and alterations.**

Each building or part of a building that is constructed or altered by, on behalf of, or for the use of the agency shall be designed, constructed, or altered so as to be readily accessible to and usable by handicapped persons. The definitions, requirements and standards of the Architectural Barriers Act (42 U.S.C. 4151-4157), as established in 41 CFR 101-19.600 to 101-19.607, apply to buildings covered by this section.

**§§ 1154.152-1154.159 [Reserved]**

**§ 1154.160 Communications.**

(a) The agency shall take appropriate steps to ensure effective communication with applicants, participants, personnel of other Federal entities, and members of the public.

(1) The agency shall furnish appropriate auxiliary aids where necessary to afford a handicapped person an equal opportunity to participate in, and enjoy the benefits of, the program or activity conducted by the agency.

(i) In determining what type of auxiliary aid is necessary, the agency shall give primary consideration to the requests of the handicapped person.

(ii) The agency need not provide individually prescribed devices, readers for personal use or study, or other devices of a personal nature.

(2) Where the agency communicates with applicants, beneficiaries, and members of the public by telephone,

**36 CFR Ch. XI (7-1-03 Edition)**

telecommunications devices for deaf persons (TDD's) or equally effective telecommunication systems shall be used.

(b) The agency shall ensure that interested person, including persons with impaired vision, speech or hearing, can obtain information as to the existence and location of accessible services, activities, and facilities.

(c) The agency shall provide signage at a primary entrance to each of its inaccessible facilities, directing users to a location at which they can obtain information about accessible facilities. The international symbol for accessibility shall be used at each primary entrance of an accessible facility.

(d) This section does not require the agency to take any action that it can demonstrate would result in a fundamental alteration in the nature of a program or activity or in undue financial and administrative burdens.

In those circumstances where agency personnel believe that the proposed action would fundamentally alter the program or activity or would result in undue financial and administrative burdens, the agency has the burden of proving that compliance with § 1154.160 would result in such alteration or burdens. The decision that compliance would result in such alteration or burdens must be made by the agency head or his/her designee after considering all agency resources available for use in the funding and operation of the conducted program or activity, and must be accompanied by a written statement of the reasons for reaching that conclusion. If an action required to comply with this section would result in such an alteration or such burdens, the agency shall take any other action that would not result in such an alteration or such burdens but would nevertheless ensure that, to the maximum extent possible, handicapped persons receive the benefits and services of the program or activity.

[52 FR 16380, May 5, 1987, as amended at 53 FR 24265, June 28, 1988]

**§§ 1154.161-1154.169 [Reserved]**

**§ 1154.170 Compliance procedures.**

(a) Except as provided in paragraph (b) of this section, this section applies

to all allegations of discrimination on the basis of handicap in programs or activities conducted by the agency.

(b) The agency shall process complaints alleging violations of section 504 with respect to employment according to the procedures established by the Equal Employment Opportunity Commission in 29 CFR part 1613 pursuant to section 501 of the Rehabilitation Act of 1973 (29 U.S.C. 791).

(c) Responsibility for implementation and operation of this section shall be vested in the Equal Employment Opportunity Director.

(d) Complaints may be delivered or mailed to the Equal Employment Opportunity Director, ATBCB, 330 C Street, SW., Rm. 1010, Washington, DC 20202.

(e) The agency shall accept and investigate all complete complaints over which it has jurisdiction. All complete complaints must be filed within 180 days of the alleged act of discrimination. The agency may extend this time period for good cause.

(f) If the Equal Employment Opportunity Director receives a complaint that is not complete, he or she shall notify the complainant, within 30 days of receipt of the incomplete complaint, that additional information is needed. If the complainant fails to complete the complaint within 30 days of receipt of this notice, the Equal Employment Opportunity Director shall dismiss the complaint without prejudice, and shall notify the complainant of such dismissal.

(g) If the agency receives a complaint over which it does not have jurisdiction, it shall promptly notify the complainant and shall make reasonable efforts to refer the complaint to the appropriate government entity.

(h) The agency shall notify the Director of the Compliance and Enforcement Division of any complaint alleging that a building or facility is not readily accessible to and usable by handicapped persons. The Director of the Compliance and Enforcement Division shall determine whether or not the building or facility is subject to the Architectural Barriers Act of 1968, as amended (42 U.S.C. 4151-4157), or section 502 of the Rehabilitation Act of 1973, as amended (29 U.S.C. 792).

(i) Within 180 days of the receipt of a complete complaint over which it has jurisdiction, the agency shall notify the complainant of the results of the investigation in a letter containing—

(1) Findings of fact and conclusions of law;

(2) A description of a remedy for each violation found; and

(3) A notice of the right to appeal.

(j) Appeals of the findings of fact and conclusions of law or remedies must be filed by the complainant within 90 days of receipt from the agency of the letter required by §1154.170(g). The agency may extend this time for good cause.

(k) Timely appeals shall be accepted and processed by the head of the agency.

(l) The head of the agency shall notify the complainant of the results of the appeal within 60 days of the receipt of the request. If the head of the agency determines that additional information is needed from the complainant, he/she shall have 60 days from the date of receipt of the additional information to make his/her determination on the appeal.

(m) The time limits cited in paragraphs (i) and (l) of this section may be extended with the permission of the Assistant Attorney General.

(n) The agency may delegate its authority for conducting complaint investigations to other Federal agencies, except that the authority for making the final determination may not be delegated to another agency.

**PART 1190—MINIMUM GUIDELINES AND REQUIREMENTS FOR ACCESSIBLE DESIGN**

**Subpart A—General**

Sec.

1190.1 Purpose.

1190.2 Applicability: Buildings and facilities subject to guidelines and standards.

1190.3 Definitions.

1190.4 Issuance of Architectural Barriers Act standards by standard-setting agencies.

1190.5 Guidelines: Other uses.

1190.6 Interpretation of guidelines.

1190.7 Severability.

**Subpart B—Scope**

1190.30 Scope. [Reserved]

## § 1190.1

- 1190.31 Accessible buildings and facilities:  
New construction.  
1190.32 Accessible buildings and facilities:  
Additions.  
1190.33 Accessible buildings and facilities:  
Alterations.  
1190.34 Accessible buildings and facilities:  
Leased.

### Subpart C—Technical Provisions

- 1190.40 Technical specifications.  
1190.50 Exceptions.

### Subpart D—Special Building or Facility Types or Elements

- 1190.60 Special building or facility types.

AUTHORITY: Sec. 502(b), Rehabilitation Act of 1973 (29 U.S.C. 792(b)(7)), as amended by the Rehabilitation, Comprehensive Services, and Developmental Disabilities Amendments of 1978 (sec. 119, Pub. L. 602, 92 Stat. 2982, and the Rehabilitation Act Amendments of 1986 (Pub. L. 99-506, 100 Stat. 1801).

SOURCE: 47 FR 33864, Aug. 4, 1982, unless otherwise noted.

### Subpart A—General

#### § 1190.1 Purpose.

The purpose of this part is to implement section 502(b)(7) of the Rehabilitation Act of 1973 (29 U.S.C. 792(b)(7)), as amended, which requires the Architectural and Transportation Barriers Compliance Board to establish minimum guidelines and requirements for standards issued under the Architectural Barriers Act of 1968 (42 U.S.C. 4151 *et seq.*), as amended. This part and the standards to be based on it are intended to ensure that certain buildings and facilities financed with Federal funds are designed, constructed, or altered so as to be readily accessible to, and usable by, physically handicapped persons.

#### § 1190.2 Applicability: Building and facilities subject to guidelines and standards

(a) *Definitions.* As used in this section, the term:

(1) *Constructed or altered on behalf of the United States* means constructed or altered for purchase by the United States, or constructed or altered for the use of the United States.

(2) *Primarily for use by able-bodied military personnel* means expected to be occupied, used, or visited principally by

## 36 CFR Ch. XI (7–1–03 Edition)

military service personnel. Examples of buildings so intended are barracks, officers' quarters, and closed messes.

(3) *Privately owned residential structures* means a single or multifamily dwelling not owned by a unit or subunit of Federal, state, or local government.

(b) *Buildings and facilities covered.* Except as provided in paragraph (c) of this section, the standards to be issued by the standard-setting agencies in conformance with these minimum guidelines and requirements apply as provided in paragraph (d) of this section to any building or facility—

(1) The intended use for which either—

(i) Will require that such building or facility be accessible to the public, or

(ii) May result in employment or residence therein of physically handicapped persons; and

(2) Which is—

(i) To be constructed or altered by or on behalf of the United States;

(ii) To be leased in whole or in part by the United States after August 12, 1968, and before January 1, 1977, after construction or alteration in accordance with plans and specifications of the United States;

(iii) To be leased in whole or in part by the United States on or after January 1, 1977;

(iv) To be financed in whole or in part by a grant or loan made by the United States after August 12, 1968, if the building or facility may be subject to standards for design, construction, or alteration issued under the law authorizing the grant or loan; or

(v) To be constructed under the authority of the National Capital Transportation Act of 1960, the National Capital Transportation Act of 1965, or Title III of the Washington Metropolitan Area Transit Regulation Compact.

(c) *Buildings and facilities not covered.* The guidelines and requirements and the standards do not apply to—

(1) Any privately owned residential structure, unless it is leased by the Federal government on or after January 1, 1977, for subsidized housing programs; or

(2) Any building or facility on a military installation designed and constructed primarily for use by able-bodied military personnel.

(d) *Application and effective date of standards.* Any covered building or facility, as provided in this section, which is designed, constructed, or altered after the effective date of a standard issued in conformance with this guideline which is applicable to the building or facility, shall be designed, constructed, or altered in accordance with the standard. Any other building or facility covered by the Architectural Barriers Act, if and when required by law, shall comply with such standards issued in conformance with this part as are appropriate.

[47 FR 33864, Aug. 4, 1982, as amended at 54 FR 5444, Feb. 3, 1989]

### § 1190.3 Definitions.

As used in this part, the term:

*ATBCB* means the Architectural and Transportation Barriers Compliance Board.

*Access aisle* means a pedestrian space between elements such as parking spaces, seating, and desks.

*Accessible* means in compliance with the specifications and requirements of any applicable standard issued by a standard-setting agency in conformance with this part. *Accessible* describes a site, building, facility, or portion thereof that complies with these requirements, and that can be approached, entered, and used by physically handicapped persons. Accessible elements and spaces of a building or facility including doors provided adjacent to a turnstile or a revolving door, shall be subject to the same use patterns as other elements and spaces of the building or facility.

*Accessible route* means a continuous unobstructed path connecting accessible elements and spaces in a building or facility and complying with the space and reach requirements of any standard issued by a standard-setting agency in conformance with this part. (Interior accessible routes may include but are not limited to corridors, floors, ramps, elevators, lifts, and clear floor space at fixtures. Exterior accessible routes may include but are not limited

to parking access aisles, curb ramps, walks, ramps, and lifts.)

*Accessible space* means a space that complies with any standard issued by a standard-setting agency in conformance with this part.

*Adaptability* means the capability of certain building spaces and elements, such as kitchen counters, sinks and grab bars, to be altered or added to so as to accommodate the needs of persons with or without disabilities, or to accommodate the needs of persons with different types or degrees of disability.

*Addition* means an expansion, extension, or increase in the gross floor area of a building or facility.

*Agency* means a Federal department, agency or instrumentality, as defined in sections 551(1) and 701(b)(1) of title 5, United States Code, or an official authorized to represent an agency.

*Alteration* means any change in a building or facility or its permanent fixtures or equipment. It includes, but is not limited to, remodeling, renovation, rehabilitation, reconstruction, changes or rearrangement in structural parts, and extraordinary repairs. It does not include normal maintenance, reroofing, interior decoration, or changes to mechanical systems.

*Architectural Barriers Act* means the Architectural Barriers Act of 1968, Pub. L. 90-480, as amended, 42 U.S.C. 4151 *et seq.*

*Assembly area* means a room or space accommodating fifty or more individuals for religious, recreational, educational, political, social, or amusement purposes, or for the consumption of food and drink, and including all connected rooms or spaces with a common means of egress and ingress. Such areas as conference and meeting rooms accommodating fewer than fifty individuals are not considered assembly areas.

*Automatic door* means a door—

- (1) Used for human passage and
- (2) Equipped with a power-operated mechanism and controls that open and close the door upon receipt of a momentary actuating signal.

*Building or facility* means all or any portion of buildings, structures, equipment, roads, walks, parking lots, parks, sites, or other real property or interest in such property.

*Circulation path* means an exterior or interior way of passage from one place to another for pedestrians, including, but not limited to, walks, hallways, courtyards, stairways, and stair landings.

*Clear* means unobstructed.

*Common use areas* means those interior and exterior rooms, spaces or elements that are made available for the use of a restricted group of people (for example, residents of an apartment building, the occupants of an office building, or the guests of such residents or occupants).

*Construction* means any erection of a new building or of an addition to an existing building or facility.

*Cross slope* means the slope that is perpendicular to the direction of travel (see *running slope*).

*Curb ramp* means a short ramp cutting through a curb or built up to it.

*Detectable* means perceptible by one or more of the senses.

*Detectable warning* means a standardized surface texture applied to or built into walking surfaces or other elements to warn visually impaired people of hazards in the path of travel.

*Dwelling unit* means a single unit of residence that provides a kitchen or food preparation area, in addition to rooms and spaces for living, bathing, sleeping, and the like.

A single family home is a dwelling unit, and dwelling units are to be found in such housing types as townhouses and apartment buildings.

*Egress* or *means of egress* means a continuous and unobstructed way of exit travel from any point in a building or facility to an exterior walk or out of a fire zone. It includes all intervening rooms, spaces, or elements.

*Element* means an architectural or mechanical component of a building, facility, space, or site, e.g., telephone, curb ramp, door, drinking fountain, seating, water closet.

*Entrance* means any access point to a building or portion of a building or facility used for the purpose of entering. An entrance includes the approach walk, the vertical access leading to the entrance platform, the entrance platform itself, vestibules if provided, the entry door(s) or gate(s), and the hardware of the entry door(s) or gate(s).

The principal entrance of a building or facility is the main door through which most people enter.

*Essential features* means those elements and spaces that make a building or facility usable by, or serve the needs of, its occupants or users. Essential features include but are not limited to entrances, toilet rooms, and accessible routes. Essential features do not include those spaces that house the major activities for which the building or facility is intended, such as classrooms and offices.

*Exception* means a special provision in this part or in a standard which indicates an acceptable alternative, under specified circumstances, to a requirement stated directly above the exception.

*Extraordinary repair* means the replacement or renewal of any element of an existing building or facility for purposes other than normal maintenance.

*Full and fair cash value* is calculated for the estimated date on which work will commence on a project and means—

(1) The assessed valuation of a building or facility as recorded in the assessor's office of the municipality and as equalized at one hundred percent (100%) valuation—

(NOTE: The one hundred percent (100%) equalized assessed value shall be based upon the state's most recent determination of the particular city's or town's assessment ratio.

*Example:* Town X has an assessment ratio of forty percent (40%), and the particular building in question is assessed at \$200,000.00. To determine the equalized assessed value of this building, divide \$200,000.00 by .40, and the equalized assessed value equals \$500,000.00.);

(2) The replacement cost; or

(3) The fair market value.

*Guidelines and requirements* means this part.

*Housing* means a building, facility, or portion thereof, excluding inpatient health care facilities, that contains one or more dwelling units or sleeping accommodations. Housing may include, but is not limited to, one-family and two-family dwellings, multifamily dwellings, group homes, hotels, motels, dormitories, and mobile homes.

*Marked crossing* means a crosswalk or other identified path intended for pedestrian use in crossing a vehicular way.



*Multifamily housing* means a project containing five or more dwelling units.

*Operable part* means a part of equipment or an appliance used to insert or withdraw objects, to activate or deactivate equipment, or to adjust the equipment (e.g., coin slot, push button, handle).

*Physically handicapped person* means an individual who has a physical impairment, including impaired sensory, manual, or speaking abilities, which results in a functional limitation in access to and use of a building or facility.

*Power-assisted door* means a door—

(1) Used for human passage; and

(2) With a mechanism that helps to open the door, or relieve the opening resistance of a door, upon the activation of a switch or a continued force applied to the door itself.

*Public use* means any interior and exterior rooms or spaces made available to the general public. Public use may be provided at a building or facility that is privately or publicly owned.

*Ramp* means a walking surface that has a running slope greater than 1:20.

*Reconstruction* means the act or process of reproducing by new construction the exact form and detail of a vanished building, structure, or object, or a part thereof, as it appeared at a specific period of time.

*Restoration* means the act or process of accurately recovering the form and details of a property and its setting as it appeared at a particular period of time by means of the removal of later works or by replacement of missing earlier work.

*Running slope* means the slope that is parallel to the direction of travel (see *cross slope*).

*Section 502 of the Rehabilitation Act or section 502* means section 502 of the Rehabilitation Act of 1973, Pub. L. 93-112, 29 U.S.C. 792, as amended.

*Service entrance* means an entrance intended primarily for delivery or service.

*Shall* denotes a mandatory requirement.

*Signage* means the display of written, symbolic, tactile, or pictorial information.

*Site* means a parcel of land bounded by a property line or a designated portion of a public right-of-way.

*Site improvements* means landscaping, paving for pedestrian and vehicular ways, outdoor lighting, recreational facilities, and similar site additions.

*Sleeping accommodations* means rooms in which people sleep (for example, dormitory and hotel or motel guest rooms).

*Space* means a definable area, e.g., toilet room, hall, assembly area, parking area, entrance, storage room, alcove, courtyard, or lobby.

*Standard* means any standard for accessibility issued under the Architectural Barriers Act.

*Standard-setting agency* means one of the four agencies required to issue standards under the Architectural Barriers Act, i.e., the General Services Administration, the Department of Housing and Urban Development, the Department of Defense, and the United States Postal Service.

*Structural impracticability* means having little likelihood of being accomplished without removing or altering a load-bearing structural member and/or incurring an increased cost of 50 percent or more of the value of the element of the building or facility involved.

*Tactile* means perceptible through the sense of touch.

*Temporary* means elements are not permanent (i.e., installed for less than six months) and are not required for safety reasons.

*Walk* means an exterior pathway or space with a prepared surface intended for pedestrian use and having a slope of 1:20 or less. It includes general pedestrian areas such as plazas and courts.

[47 FR 33864, Aug. 4, 1982, as amended at 54 FR 5444, Feb. 3, 1989]

#### **§ 1190.4 Issuance of Architectural Barriers Act standards by standard-setting agencies.**

(a) These guidelines and requirements are the minimum guidelines and requirements for standards issued under the Architectural Barriers Act by the Administrator of General Services, Secretary of Housing and Urban Development, Secretary of Defense, and Postmaster General.

(b) Standards which conform to or exceed the provisions of the guidelines

## § 1190.5

shall be deemed in compliance with the guidelines and requirements.

(c) Each standard-setting agency is encouraged to issue standards which follow the format of these guidelines and requirements. However, standards which differ in format from these guidelines and requirements but are otherwise consistent with the guidelines and requirements shall be deemed in compliance with these guidelines and requirements.

### § 1190.5 Guidelines: Other uses.

These minimum guidelines and requirements and those standards published by the four standard-setting agencies under the Architectural Barriers Act of 1968, as amended, may be used by other governmental and non-governmental entities, along with other sources, to develop their own standards.

### § 1190.6 Interpretation of guidelines.

(a) These guidelines and requirements shall be liberally construed to carry out the purposes and provisions of the Architectural Barriers Act and section 502 of the Rehabilitation Act.

(b) Words importing the singular number may extend and be applied to the plural and vice versa. However, unless otherwise specified in the guidelines and requirements, each element or space of a particular building or facility shall comply with the guidelines and requirements.

(c) Use of the imperative mood, *e.g.*, "provide," means the provision is mandatory. This form is being used to avoid wordiness and monotony but means the same as if the word "shall" had been included.

(d) The provisions in the minimum guidelines and requirements are based upon adult dimensions and anthropometrics.

(e) Dimensions that are not marked "minimum" or "maximum" are absolute, unless otherwise indicated in the text or captions. All dimensions are subject to conventional building tolerances for field conditions.

### § 1190.7 Severability.

If any section, subsection, paragraph, sentence, clause, or phrase of these guidelines and requirements is declared

## 36 CFR Ch. XI (7-1-03 Edition)

invalid for any reason, the remaining portions of these guidelines and requirements that are severable from the invalid part shall remain in full force and effect. If a part of these guidelines and requirements is invalid in one or more of its applications, the part shall remain in effect in all valid applications that are severable from the invalid applications.

[47 FR 33864, Aug. 4, 1982. Redesignated at 54 FR 5444, Feb. 3, 1989]

## Subpart B—Scope

### § 1190.30 Scope. [Reserved]

### § 1190.31 Accessible buildings and facilities: New construction.

Except as otherwise provided in this part, all new construction of buildings and facilities shall comply with the minimum requirements set forth below. The citations beginning with "ANSI" in the provisions which follow refer to the sections of the American National Standard, ANSI A117.1-1986, "Providing Accessibility and Usability for Physically Handicapped People" by the American National Standards Institute, Inc. This incorporation by reference was approved by the Director of the Federal Register in accordance with 5 U.S.C. 552(a) and 1 CFR part 51. Copies may be obtained from the American National Standards Institute, Inc., 1430 Broadway, New York, NY 10018. Copies may be inspected at the office of the U.S. Architectural and Transportation Barriers Compliance Board, 1111 18th Street, NW., Suite 501, Washington, DC or at the Office of the Federal Register, 800 North Capitol Street, NW., suite 700, Washington, DC.

(a) Accessible route. At least one accessible route shall comply with ANSI A117.1-1986, section 4.3, Accessible Routes (Incorporated by reference, see this paragraph (a).)

(1) Required accessible route(s) shall connect an accessible building entrance with:

(i) Transportation facilities located within the property line of a given site, including passenger loading zones, public transportation facilities, taxi stands, and parking;

(ii) Public streets and sidewalks;

(iii) Other accessible buildings, facilities, elements, and spaces that are on the same site; and

(iv) All accessible spaces, rooms, and elements within the building or facility.

(2) Where fire code provisions require more than one means of egress from any space or room, then more than one accessible means of egress complying with ANSI A117.1-1986, section 4.3.10 shall be provided for handicapped people and shall be arranged so as to be readily accessible from all accessible rooms and spaces (Incorporated by reference, see § 1190.31(a).)

(b) *Parking and passenger loading zones.* (1) If any parking is provided, for employees or visitors, or both, each such parking area shall comply with ANSI A117.1-1986 section 4.6 Parking Spaces and Passenger Loading Zones (Incorporated by reference, see paragraph (a) of this section), and the following table:

Total parking in lot	Required minimum number of accessible spaces
1 to 25 .....	1.
26 to 50 .....	2.
51 to 75 .....	3.
76 to 100 .....	4.
101 to 150 .....	5.
151 to 200 .....	6.
201 to 300 .....	7.
301 to 400 .....	8.
401 to 500 .....	9.
501 to 1,000 .....	2 pct of total.
Over 1,000 .....	20 plus 1 for each 100 over 1,000.

Passenger loading zones shall provide an access aisle at least 60 in (1525 mm) wide and 20 ft (60 mm) long adjacent and parallel to the vehicle pull-up space. If there are curbs between the access aisle and the vehicle pull-up space, then a curb ramp complying with ANSI A117.1-1986, section 4.7 shall be provided. A minimum vertical clearance of 114 in (3.45 m) shall be provided at accessible passenger loading zones and along vehicle access routes to such areas from site entrances.

(i) *Exception:* The total number of accessible parking spaces may be distributed among parking lots, if greater accessibility is achieved.

(ii) *Exception:* This paragraph does not apply to parking provided for official government vehicles owned or leased by the government and used exclusively for government purposes.

Parking spaces for side lift vans are accessible parking spaces and may be used to meet the requirements of this paragraph.

(2) If passenger loading zones are provided, at least one passenger loading zone shall comply with ANSI A117.1-1986 section 4.6 Parking Spaces and Passenger Loading Zones (Incorporated by reference, see paragraph (a) of this section).

(c) *Ramps and curb ramps.* If there is an abrupt level or grade change, if the slope is greater than 1:20, and if no other means of accessible vertical access is provided, a ramp or curb ramp shall be provided. If a ramp or curb ramp is provided, it shall comply with ANSI A117.1-1986, section 4.7 Curb Ramps or 4.8 Ramps, as appropriate (Incorporated by reference, see paragraph (a) of this section.).

(d) *Stairs.* Except as provided in paragraph (f)(1) of this section, stairs connecting levels that are not connected by an elevator shall comply with ANSI A117.1-1986, section 4.9, Stairs. (Incorporated by reference, see paragraph (a) of this section.)

(e) *Handrails.* Handrails shall be provided at each ramp and staircase as required in ANSI A117.1-1986, sections 4.8 Ramps and 4.9 Stairs, respectively. (Incorporated by reference, see paragraph (a) of this section.)

(f) *Elevators.* One passenger elevator complying with ANSI A117.1-1986, section 4.10, Elevators (incorporated by reference, see paragraph (a) of this section) shall serve each level in all multi-story buildings and facilities. If more than one elevator is provided, each elevator shall comply with ANSI A117.1-1986, section 4.10, Elevators (incorporated by reference, see paragraph (a) of this section). All elevator control buttons shall be at least ¾ in (19mm) in their smallest dimension. They shall be raised or flush.

(1) *Exception.* Elevator pits, elevator penthouses, mechanical rooms, piping, or equipment catwalks are excepted from this requirement.

(2) *Exception.* Ramps or platform lifts complying with ANSI A117.1-1986, section 4.8 Ramps and ANSI A117.1-1986, section 4.11 Platform Lifts (incorporated by reference, see paragraph (a)

## § 1190.31

## 36 CFR Ch. XI (7-1-03 Edition)

of this section), respectively, may be used in lieu of an elevator.

(g) *Platform lifts.* If the slope is greater than 1:20, and if no other means of accessible vertical access is provided, a platform lift may be provided if there is an abrupt level or grade change. If a platform lift is provided, it shall comply with ANSI A117.1-1986, section 4.11 Platform Lifts (incorporation by reference, see paragraph (a) of this section), and should facilitate unassisted entry and exit from the lift.

(h) *Entrances.* At least one principal entrance at each grade floor level to a building or facility shall comply with ANSI A117.1-1986, section 4.14, Entrances (incorporated by reference, see paragraph (a) of this section). When a building or facility has entrances which normally serve any of the following functions: transportation facilities, passenger loading zones, accessible parking facilities, taxi stands, public streets and sidewalks, accessible interior vertical access, then at least one of the entrances serving each such function shall comply with ANSI A117.1-1986, section 4.14, Entrances (incorporated by reference, see paragraph (a) of this section). Because entrances also serve as exits, particularly in cases of emergency, the proximity of such accessible entrances and exits to all parts of the building is essential. It is preferable that all or most entrances and exits be accessible. One entrance may serve more than one function.

(i) *Doors.* (1) At each accessible entrance to a building or facility, at least one door shall comply with ANSI A117.1-1986, section 4.13, Doors (incorporated by reference, see paragraph (a) of this section).

(2) Within a building or facility, at least one door at each accessible entrance to the accessible space shall comply with ANSI A117.1-1986, section 4.13, Doors (incorporated by reference, see paragraph (a) of this section).

(3) Each door required by ANSI A117.1-1986, section 4.3.10, Egress (incorporated by reference, see paragraph (a) of this section), shall comply with ANSI A117.1-1986, section 4.13, Doors (incorporated by reference, see paragraph (a) of this section).

(4) Each door that is an element of an accessible route shall comply with

ANSI A117.1-1986, section 4.13, Doors (incorporated by reference, see paragraph (a) of this section).

(j) *Windows.* If operable windows are provided, they shall comply with ANSI A117.1-1986, section 4.12 Windows. (Incorporated by reference, see paragraph (a) of this section.)”

(k) *Toilet and bathing facilities.* If toilet and bathing facilities are provided, then each public and common use toilet room shall comply with ANSI A117.1-1986, section 4.22, Toilet Rooms, Bathrooms, Bathing Facilities and Shower Rooms (incorporated by reference, see paragraph (a) of this section). Other toilet rooms shall be adaptable. If bathing facilities are provided, then each public and common use bathing facility shall comply with ANSI A117.1-1986, section 4.22. In each such facility where any of the fixtures and accessories specified in ANSI A117.1-1986, section 4.16, Water Closets; ANSI A117.1-1986, section 4.17, Toilet Stalls; ANSI A117.1-1986, section 4.18, Urinals; ANSI A117.1-1986, section 4.19, Lavatories, Sinks and Mirrors; ANSI A117.1-1986, section 4.20, Bathtubs; and ANSI A117.1-1986, section 4.21, Shower Stalls, are provided, at least one accessible fixture and accessory of each type provided shall comply with the provisions in the subsection applicable to that fixture or accessory. The size and arrangement of toilet stalls shall comply with ANSI Fig. 30(a). Toilet stalls with a minimum depth of 56 in (1420 mm) (see ANSI Fig. 30(a)) shall have wall-mounted closets. If the depth of toilet stalls is increased at least 3 in (75 mm), then a floor mounted water closet may be used. Arrangements shown for toilet stalls may be reversed to allow either a left-hand or right-hand approach. Installation of a fixed shower head may be permitted in lieu of an adjustable height or hand-held shower head in unmonitored facilities where vandalism is a concern. Curbs in shower stalls that are 36 in by 36 in (915 mm by 915 mm) shall have a maximum height of ½ in (13 mm). Bathrooms in dwelling units required to be accessible shall comply with ANSI A117.1-1986, section 4.32.4, Bathrooms. For special use situations, refer to Subpart E, Special Building or Facility Types or Elements.

(l) *Drinking fountains and water coolers.* If drinking fountains or water coolers are provided, approximately 50% of those provided on each floor shall comply with ANSI A117.1-1986, section 4.15, Drinking Fountains and Water Coolers, (incorporated by reference, see paragraph (a) of this section), and shall be dispersed throughout the floor. If only one drinking fountain or water cooler is provided on any floor, it shall comply with ANSI A117.1-1986, section 4.15. It is preferred that if only one drinking fountain or water cooler is provided on any floor, then it should have two levels with the lower level complying with ANSI A117.1-1986, section 4.15.

(m) *Controls and operating mechanisms.* If controls and operating mechanisms are provided in accessible spaces, along accessible routes or as parts of accessible elements, each shall comply with ANSI A117.1-1986, section 4.25, Controls and Operating Mechanisms. (Incorporated by reference, see paragraph (a) of this section.)

(n) *Alarms.* If alarm systems are provided, each shall comply with ANSI A117.1-1986, section 4.26, Alarms (incorporated by reference, see paragraph (a) of this section). In facilities with sleeping accommodations, the sleeping accommodations required to be accessible shall have an alarm system complying with ANSI A117.1-1986, section 4.26.4, Auxiliary Alarms. Emergency warning systems in health care facilities may be modified to suit standard health care alarm design practice.

(o) *Detectable warnings.* Detectable warnings complying with ANSI A117.1-1986, section 4.27.3, Tactile Warnings on Doors to Hazardous Areas (incorporated by reference, see paragraph (a) of this section), shall be provided on the hardware of all doors leading to hazardous areas. Such warnings shall not be used at emergency exit doors. Detectable warnings are not required at locations other than doors to hazardous areas by this part. If detectable warnings are provided, the specifications at ANSI A117.1-1986, section 4.27 may be used as guidance.

NOTE: The ATBCB has funded research in the area of detectable tactile surface treatments. The research findings were inconclusive and, therefore, recommended no mandatory requirements at this time. Further in-

formation is being developed through additional research on detectable materials and fact-finding on current applications, particularly on transit platforms. Technical assistance materials including information about additional detectable cues (sound and resiliency) not discussed in ANSI are available from the ATBCB, 1111 18th Street, NW, Suite 501, Washington, DC 20036, (202) 653-7834 (voice or TDD).

(p) *Signage.* Signage shall comply with ANSI A117.1-1986, section 4.28, Signage (incorporated by reference, see paragraph (a) of this section). Permanent signage that identifies rooms and spaces shall also comply with ANSI A117.1-1986, section 4.28.4. Exception: The provisions of ANSI A117.1-1986, section 4.28.4 are not mandatory for temporary information on room and space signage, such as current occupant's name, provided the permanent room or space identification complies with ANSI A117.1-1986, section 4.28.4.

(q) *Telephones.* (1) If public telephones are provided, then accessible public telephones shall comply with ANSI A117.1-1986, section 4.29, Telephones (incorporated by reference, see paragraph (a) of this section), and the following table:

Number of public telephones provided on each floor	Number of telephones required to be accessible <sup>1</sup>
One or more single unit installations.	One per floor.
One bank <sup>2</sup> .....	One per floor.
Two or more banks <sup>2</sup> .....	One per bank. Accessible unit may be installed as a single unit in proximity (either visible or with signage) to bank. At least one public telephone per floor shall meet the requirements for a forward reach telephone. <sup>3</sup>

<sup>1</sup> Additional public telephones may be installed at any height; however, the installation of accessible telephones is strongly recommended. Unless otherwise specified, accessible telephones may be either forward reach or side reach telephones.

<sup>2</sup> A bank consists of two or more adjacent public telephones usually installed as a unit.

<sup>3</sup> Exception for exterior installations only: If dial-tone-first service is not available, then a side reach telephone may be installed instead of the required forward reach telephone (i.e., one telephone in proximity to each bank shall meet the requirements of ANSI A117.1-1986, section 4.29, Telephones (incorporated by reference, see paragraph (a) of this section)).

(2) At least one of the public telephones complying with ANSI A117.1-1986, section 4.29, Telephones (incorporated by reference, see paragraph (a) of this section), shall be equipped with a volume control. The installation of

§ 1190.31

additional volume controls is encouraged and these may be installed on any public telephone provided.

(3) Signage. [Reserved]

(r) *Seating, tables, and work surfaces.* If fixed seating, tables, and work surfaces are provided, at least 5 percent but always at least one of each element shall comply with ANSI A117.1-1986, section 4.30, Seating, Tables and Work Surfaces. (Incorporated by reference, see paragraph (a) of this section.)

(s) *Assembly areas, conference, or meeting rooms.* (1) If assembly areas are provided, accessible viewing positions shall comply with ANSI A117.1-1986, section 4.31, Auditorium and Assembly Areas (incorporated by reference, see paragraph (a) of this section), and the following table:

Capacity of assembly area	Number of viewing positions
50 to 75 .....	3.
76 to 100 .....	4.
101 to 150 .....	5.
151 to 200 .....	6.
201 to 300 .....	7.
301 to 400 .....	8.
401 to 500 .....	9.
501 to 1,000 .....	2 pct of total.
Over 1,000 .....	20 plus 1 for each 100 over 1,000.

Accessible viewing positions may be clustered in bleachers, balconies, and other areas that have sight lines requiring slopes greater than 5 percent or to permit equivalent accessible viewing positions to be located on levels having accessible egress.

(2) Assembly areas with audio-amplification systems shall have a listening system complying with ANSI A117.1-1986, section 4.31, to assist a reasonable number of people but no fewer than two, with severe hearing loss. For assembly areas without amplification systems and for spaces used primarily as meeting and conference rooms, a permanently installed or portable listening system shall be provided. This requirement may be satisfied by use of a portable system that requires little or no installation. If portable systems are used for conference and meeting rooms, the system may serve more than one room.

(3) If performing areas are provided, accessible routes shall comply with ANSI A117.1-1986, section 4.3, Accessible Routes, to performing areas, in-

cluding but not limited to stages, arena floors, dressing rooms, locker rooms, and other rooms and spaces required for use of the assembly area. (ANSI 4.33.5)

(i) *Exception.* In alteration work where it is structurally impracticable to alter all performing areas to be on an accessible route, at least one of each type shall be made accessible. (ANSI 4.33.6\* and 4.33.7\*)

(ii) [Reserved]

(t) *Storage.* If storage facilities such as cabinets, shelves, closets and drawers are provided in accessible spaces for occupant use, at least one storage facility of each type provided shall comply with ANSI A117.1-1986, section 4.23, Storage. (Incorporated by reference, see paragraph (a) of this section.) Additional storage may be provided outside of the dimensions provided in ANSI A117.1-1986, section 4.23, Storage. (Incorporated by reference, see paragraph (a) of this section.)

(u) *Housing.* Accessible housing shall:

(1) Comply with the requirements of this section as it applies to public use and common use areas and areas where handicapped persons may be employed, except as follows:

(i) *Elevators:* Where provided, elevators shall comply with ANSI A117.1-1986, section 4.10 (incorporated by reference, see paragraph (a) of this section). All elevator control buttons shall be at least 3/4 in (19 mm) in their smallest dimension. They shall be raised or flush. Elevators or other accessible means of vertical movement are not required in residential facilities when:

(A) No accessible dwelling units are located above or below the accessible grade level; and

(B) At least one of each type of common area and amenity provided for use of residents and visitors is available at the accessible grade level.

(ii) *Entrances:* Entrances complying with ANSI 4.14 shall be provided as necessary to achieve access to and egress from buildings and facilities. EXCEPTION: In projects consisting of one-to-four family dwellings where accessible entrances would be extraordinarily costly due to site conditions or local code restrictions, accessible entrances

are required only to those buildings containing accessible dwelling units.

(iii) Common Areas: At least one of each type of common area and amenity in each project shall be accessible and shall be located on an accessible route to any accessible dwelling unit.

(2) Provide dwelling units or sleeping accommodations complying with ANSI 4.32, Dwelling Units, in accordance with the following table:

Facilities	Application
Hotels, motels, boarding houses.	5 percent of the total units, or at least one, whichever is greater.
Multifamily housing (including apartment houses) Federally assisted.	5 percent of the total, or at least one unit, whichever is greater in multifamily housing projects.
Federally owned .....	5 percent of the total, or at least one unit, whichever is greater in multifamily housing projects.
Dormitories .....	5 percent of the total, or at least one unit whichever is greater.
One and two family dwelling Federally assisted, rental.	5 percent of the total, or at least one unit, whichever is greater, in multifamily housing projects.
Federally assisted homeownership.	To be determined by home buyer.
Federally owned .....	5 percent of the total, or at least one unit, whichever is greater in multifamily housing projects.

(v) *Health care facilities.* Accessible health care facilities shall:

(1) Comply with the requirements of this section, as it applies to public use and common use areas and areas where handicapped persons may be employed; and

(2) Provide patient rooms and patient toilet rooms complying with Part 6 of UFAS in accordance with the following table:

Facilities	Application
Long term care facilities (including skilled nursing facilities, intermediate care facilities, bed and care, and nursing homes).	At least 50 percent of patient toilets and bedrooms.
Outpatient facilities .....	All patient toilets and bedrooms.
Hospital:	
General purpose hospital .....	At least 10 percent of patient toilets and bedrooms.
Special purpose hospital (hospitals that treat conditions that affect mobility).	All patient toilets and bedrooms.

[47 FR 33864, Aug. 4, 1982. Redesignated and amended at 54 FR 5444, Feb. 3, 1989; 54 FR 34977, Aug. 23, 1989]

**§ 1190.32 Accessible buildings and facilities: Additions.**

Each addition to an existing building or facility shall comply with § 1190.31, New construction, except as follows:

(a) *Entrances.* If a new addition to a building or facility does not have an entrance, then at least one entrance in the existing building or facility shall comply with ANSI A117.1-1986, section 4.14, Entrances. (The citations beginning with "ANSI" in this section refer to the sections of the American National Standard, ANSI A117.1-1986, "Providing Accessibility and Usability for Physically Handicapped People" by the American National Standards Institute, Inc. which has been approved for incorporation by reference as set forth in § 1190.31(a).

(b) *Accessible route.* If the only accessible entrance to the addition is located in the existing building or facility, then at least one accessible route shall comply with ANSI A117.1-1986, section 4.3, Accessible Route (incorporated by reference, see § 1190.31(a)), and shall provide access through the existing building or facility to all rooms, elements, and spaces in the new addition.

(c) *Toilet and bathing facilities.* If there are no toilet rooms and bathing facilities in the addition and these facilities are provided in the existing building, then at least one toilet and bathing facility in the existing building shall comply with ANSI A117.1-1986, section 4.22, Toilet Rooms, Bathrooms, Bathing Facilities and Shower Rooms. (Incorporated by reference, see § 1190.31(a).)

(d) *Elements, spaces, and common areas.* If elements, spaces, or common areas are located in the existing building and they are not provided in the addition, consideration should be given to making those elements, spaces, and common areas accessible in the existing building.

(e) *Exception.* Mechanical rooms, storage areas, and other such minor additions which normally are not frequented by the public or employees of the facility are excepted from paragraphs (a), (b), (c) and (d) of this section.

[47 FR 33864, Aug. 4, 1982. Redesignated and amended at 54 FR 5444, 5446, Feb. 3, 1989]

**§ 1190.33 Accessible buildings and facilities: Alterations.**

(a) *General.* Alterations to existing buildings or facilities shall comply with the following:

(1) If existing elements, spaces, essential features, or common areas are altered, then each such altered element, space, feature, or area shall comply with the applicable provisions of § 1190.31, Accessible buildings and facilities: New construction, except as noted in paragraph (a)(2) of this section.

(2) Exceptions to the requirements for (a)(1) of this section for existing buildings or facilities are:

(i) *Stairs.* Full extension of stair handrails shall not be required in alterations where such extensions would be hazardous or impossible due to plan configuration.

(ii) *Elevators.* (A) If a safety door edge is provided in existing automatic elevators, then the automatic door reopening devices may be omitted (see ANSI A117.1-1986 section 4.10.6). (The citations beginning with "ANSI" in this section refer to the sections of the American National Standard, ANSI A117.1-1986, "Providing Accessibility and Usability for Physically Handicapped People" by the American National Standards Institute, Inc. which has been approved for incorporation by reference as set forth in § 1190.31(a).

(B) Where existing shaft or structural elements prohibit strict compliance with ANSI A117.1-1986, section 4.10.9 (incorporated by reference, see § 1190.31(a)), then the minimum floor area dimensions may be reduced by the minimum amount necessary, but in no case shall they be less than 48 in by 48 in (1220 mm by 1220 mm).

(iii) *Doors.* (A) Where existing elements prohibit strict compliance with the clearance requirements of ANSI 4.13.5, a projection of 5/8 in (16 mm) maximum will be permitted for the latch side door stop. (The citations beginning with "ANSI" in this section refer to the sections of the American National Standard, ANSI A117.1-1986, "Providing Accessibility and Usability for Physically Handicapped People" by the American National Standards Institute, Inc. which has been approved

for incorporation by reference as set forth in § 1190.31(a).)

(B) If existing thresholds measure  $\frac{3}{4}$  in (19 mm) high or less, and are beveled or modified to provide a beveled edge on each side, then they may be retained.

(iv) *Toilet rooms.* Where alterations to existing facilities make strict compliance with ANSI A117.1-1986, sections 4.22 and 4.23 (incorporated by reference, see § 1190.31(a)) structurally impracticable, the addition of one "unisex" toilet per floor containing one water closet complying with ANSI A117.1-1986, section 4.16 and one lavatory complying with ANSI A117.1-1986, section 4.19, located adjacent to existing toilet facilities, will be acceptable in lieu of making existing toilet facilities for each sex accessible.

(v) *Assembly areas.* (A) In alterations where it is structurally impracticable to disperse seating throughout the assembly area, seating may be located in collected areas as structurally feasible. Seating shall adjoin an accessible route that also serves as a means of emergency egress.

(B) In alterations where it is structurally impracticable to alter all performing areas to be on an accessible route, then at least one of each type shall be made accessible.

(3) If power-driven vertical access equipment (e.g., escalator) is planned or installed where none existed previously, or if new stairs (other than stairs installed to meet emergency exit requirements) requiring major structural changes are planned or installed where none existed previously, then a means of accessible vertical access shall be provided that complies with ANSI A117.1-1986, section 4.8, Ramps; ANSI A117.1-1986, section 4.10, Elevators; or ANSI A117.1-1986, section 4.11, Platform Lifts (incorporated by reference, see § 1190.31(a)) except to the extent where it is structurally impracticable in transit facilities. All elevator control buttons shall be at least  $\frac{3}{4}$  in (19 mm) in their smallest dimension. They shall be raised or flush.

(4) If alterations of single elements, when considered together, amount to an alteration of a space of a building or facility, the entire space shall be made accessible.



(b) Where a building or facility is vacated and it is totally altered, then it shall comply with §1190.31 Accessible buildings and facilities: New construction, except to the extent where it is structurally impracticable.

(c) Where substantial alteration occurs to a building or facility, then each element or space that is altered or added shall comply with the applicable provisions of §1190.31, Accessible buildings and facilities: New construction, except to the extent where it is structurally impracticable and the altered building or facility shall contain:

(1) At least one accessible route complying with ANSI A117.1-1986, section 4.3, Accessible Routes (incorporated by reference, see §1190.31(a)), and paragraph (a) of this section;

(2) At least one accessible entrance complying with ANSI A117.1-1986, section 4.14, Entrances (incorporated by reference, see §1190.31(a)). If additional accessible entrances are altered, then they shall comply with paragraph (a)(1) of this section; and

(3) The following toilet facilities, whichever number is greater:

(i) At least one toilet facility for each sex in the altered building complying with ANSI A117.1-1986, section 4.22, Toilet Rooms, Bathrooms, Bathing Facilities, and Shower Rooms (incorporated by reference, see §1190.31(a));

(ii) At least one toilet facility for each sex on each substantially altered floor, where such facilities are provided, complying with ANSI A117.1-1986, section 4.22, Toilet Rooms, Bathrooms, Bathing Facilities, and Shower Rooms (incorporated by reference, see §1190.31(a));

In making the determination as to what constitutes "substantial alteration," the agency issuing standards for the facility shall consider the total cost of all alterations (including but not limited to electrical, mechanical, plumbing, and structural changes) for a building or facility within any twelve (12) month period. For guidance in implementing this provision, an alteration to any building or facility is to be considered substantial if the total cost for this twelve month period amounts to 50% or more of the full and

fair cash value of the building as defined at §1190.3.

(4) *Exception.* If the cost of the elements and spaces required by paragraphs (c) (1), (2), and (3) of this section, exceeds 15% of the total cost of all other alterations, then a schedule may be established by the standard-setting and/or funding agency to provide the required improvements within a 5 year period.

(5) *Exception.* If the alteration is limited solely to the electrical, mechanical, or plumbing system and does not involve the alteration of any elements and spaces required to be accessible under part 1190, then paragraph (c) of this section, does not apply.

(6) *Exception.* Consideration shall be given to providing accessible elements and spaces in each altered building or facility complying with:

(i) ANSI A117.1-1986, sections 4.6, Parking Spaces and Passenger Loading Zones, as modified by §1190.31(s)(1);

(ii) ANSI A117.1-1986, section 4.15, Drinking Fountains and Water Coolers;

(iii) ANSI A117.1-1986, section 4.23, Storage;

(iv) ANSI A117.1-1986, section 4.26, Alarms;

(v) ANSI A117.1-1986, section 4.29, Telephones;

(vi) ANSI A117.1-1986, section 4.30, Seating, Tables and Work Surfaces;

(vii) ANSI 4.31, Auditorium and Assembly Areas, as modified by §1190.31(s)(1). (Incorporated by reference, see §1190.31(a).)

(7) *Exception:* Mechanical rooms and other spaces which normally are not frequented by the public or employees of the facility or which by nature of their use are not required by the Architectural Barriers Act to be accessible are excepted from paragraphs (c) (1), (2), and (3) of this section.

[47 FR 33864, Aug. 4, 1982. Redesignated and amended at 54 FR 5444, 5446, Feb. 3, 1989]

#### § 1190.34 Accessible buildings and facilities: Leased.

(a) Buildings or facilities or portions thereof leased by the Federal Government shall comply with §1190.31, New construction, or shall incorporate the features listed in §1190.33(c), Alterations. Where both types of buildings are available for leasing, reasonable

## § 1190.34

## 36 CFR Ch. XI (7–1–03 Edition)

preference must be given to buildings or facilities complying with § 1190.31, New construction.

(b) If space complying with paragraph (a) of this section is not available, space may be leased only if the space meets, or is altered to meet, the following conditions:

(1) At least one accessible route is provided from an accessible entrance complying with § 1190.120, Entrances, to those areas in which the principal activities for which the building or facility was leased are conducted. Separate accessible routes may be provided to areas serving different groups of users (e.g., the public, employees).

(2) The accessible route shall comply with the requirements of § 1190.50, Walks, floors, and accessible routes, and provide access to whatever accessible facilities are either required or provided, such as accessible toilets.

(i) Toilet facilities, to the extent required for the ready intended use of the building or facility, shall be provided as follows—

(A) Where more than one toilet for each sex is provided in a building or facility, at least one toilet facility which complies with § 1190.150, Toilet and bathing facilities, shall be provided for each sex on each floor having toilets; or

(B) In a building or facility providing only one toilet for each sex, either one unisex toilet or one toilet for each sex complying with § 1190.150 shall be provided; or

(C) In a building or facility where only one toilet is provided, one unisex toilet complying with § 1190.150 shall be provided.

(ii) Parking facilities, if a parking area is included within the lease, shall be provided complying with § 1190.60, Parking and passenger loading zones, to the extent feasible.

(3) Where an agency determines that an area does not require the provision of toilets or parking facilities for the users or occupants of that area, nothing in this section shall be construed to require the provision of any such facilities.

(4) Consideration shall be given to providing accessible elements and spaces in each altered building or facility complying with:

(i) Section 1190.160 Drinking fountains and water coolers;

(ii) Section 1190.180 Alarms;

(iii) Section 1190.210 Telephones;

(iv) Section 1190.220 Seating, tables, and work surfaces;

(v) Section 1190.230 Assembly areas; and

(vi) Section 1190.240 Storage.

(c) If space leased in accordance with the requirements of paragraph (a) or (b) of this section is subsequently altered, then the alterations shall comply with the requirements of § 1190.33, Alterations.

(d) If space leased in accordance with the requirements of paragraph (a) or (b) of this section is increased by construction of an addition, the addition shall comply with § 1190.32, Additions, to the extent it is leased by the Federal Government.

(e) If leased space at the time of leasing meets past or present state or local codes or the recommended standards of the American National Standards Institute (ANSI) A117.1 for accessibility to physically handicapped people, and provides the features required by this section, the space may be used as is or altered to comply with the technical requirements of paragraph (a) or (b) of this section.

(f) Once leased space in an existing building is accessible or is made accessible hereunder, no new accessibility alterations shall be required under this subpart except where alterations or additions are made to the building which are covered by paragraphs (c) and (d) of this section.

(g) *Exceptions.* (1) If no space complying with paragraph (a) or (b) of this section is available for leasing, space as available may be leased without alterations:

(i) If the lease is necessary for officials servicing natural or human-made disasters on an emergency basis;

(ii) If the space is used on an intermittent basis; or

(iii) If the occupancy of the space is for no more than twelve months. If delays occur during the twelve months, the short-term lease may be extended for no more than an additional 12 months.

(2) Mechanical rooms and other spaces which normally are not frequented by the public or employees with handicaps of the occupant agency or which by nature of their use are not required to be accessible are excepted from this section.

[53 FR 35510, Sept. 14, 1988. Redesignated at 54 FR 5444, Feb. 3, 1989]

### Subpart C—Technical Provisions

#### § 1190.40 Technical specifications.

Features, elements and spaces required to be accessible by § 1190.31, § 1190.32, or § 1190.33 shall meet the technical requirements specified in the provisions of sections 4.2 through 4.32 of ANSI A117.1-1986, "American National Standard for Buildings and Facilities—Providing Accessibility and Usability for Physically Handicapped People," which is incorporated herein by reference, except as noted herein. This incorporation by reference was approved by the Director of the Federal Register in accordance with 5 U.S.C. 552(a) and 1 CFR part 51. Copies may be obtained from the American National Standards Institute, Inc., 1430 Broadway, New York, NY 10018. Copies may be inspected at the office of the U.S. Architectural and Transportation Barriers Compliance Board, 1111 18th Street, NW., Suite 501, Washington, DC or at the Office of the Federal Register, 800 North Capitol Street, NW., suite 700, Washington, DC.

[54 FR 5447, Feb. 3, 1989]

#### § 1190.50 Exceptions.

(a) In addition to ANSI A117.1-1986, section 4.10 (incorporated by reference, see § 1190.31(a)), Elevators, the following requirement is added: Hall call buttons provided under ANSI A117.1-1986, section 4.10.3 shall be raised or flush.

(b) Under ANSI A117.1-1986, section 4.7 (incorporated by reference, see § 1190.31(a)), Curb Ramps, and ANSI 117.1-1986, section 4.7.7, Warning Textures, and ANSI 117.1-1986, section 4.7.12, Uncurbed Intersections, shall not apply.

(c) In addition to ANSI A117.1-1986, section 4.28, Signage (incorporated by reference, see § 1190.31(a)), there is

added the requirement that interior tactile signage identifying rooms and spaces be located alongside the door on the latch side and be mounted at a height between 54 in and 66 in (1370 mm and 1675 mm) above the finished floor.

[54 FR 5447, Feb. 3, 1989]

### Subpart D—Special Building or Facility Types or Elements

#### § 1190.60 Special building or facility types.

The requirements specified in the Uniform Federal Accessibility Standards (UFAS) in sections 5, Restaurants and Cafeterias; 6, Health Care; 7, Mercantile; 8, Libraries; and 9, Postal Facilities, are deemed to satisfy minimum guidelines and requirements of the ATBCB for accessibility standards for those building and facility types.

[54 FR 5448, Feb. 3, 1989]

## PART 1191—AMERICANS WITH DISABILITIES ACT (ADA) ACCESSIBILITY GUIDELINES FOR BUILDINGS AND FACILITIES

1191.1 Accessibility guidelines.

1191.2 Temporary suspension of certain detectable warning requirements.

APPENDIX A TO PART 1191—AMERICANS WITH DISABILITIES ACT (ADA) ACCESSIBILITY GUIDELINES FOR BUILDINGS AND FACILITIES

AUTHORITY: 42 U.S.C. 12204.

SOURCE: 56 FR 35453, July 26, 1991, unless otherwise noted.

#### § 1191.1 Accessibility guidelines.

The accessibility guidelines for buildings and facilities for purposes of the Americans with Disabilities Act are found in the appendix to this part. The guidelines are issued to assist the Department of Justice and Department of Transportation to establish accessibility standards to implement the legislation.

[56 FR 45518, Sept. 6, 1991]

#### § 1191.2 Temporary suspension of certain detectable warning requirements.

The detectable warning requirements contained in §§ 4.7.7, 4.29.5, and 4.29.6 of

**Pt. 1191, App. A**

**36 CFR Ch. XI (7-1-03 Edition)**

Appendix A to this part are suspended temporarily until July 26, 2001.

[63 FR 64837, 64838, Nov. 23, 1998]

APPENDIX A TO PART 1191—AMERICANS WITH DISABILITIES ACT (ADA)  
ACCESSIBILITY GUIDELINES FOR BUILDINGS AND FACILITIES

**Americans with Disabilities Act (ADA)**

**Accessibility Guidelines  
for Buildings and Facilities**

**U.S. Architectural and Transportation Barriers  
Compliance Board (Access Board)  
1331 F Street, N.W., Suite 1000  
Washington, D.C. 20004-1111  
(202) 272-0080  
(202) 272-0082 TTY  
(202) 272-0081 FAX**

<b>ADA ACCESSIBILITY GUIDELINES FOR BUILDINGS AND FACILITIES TABLE OF CONTENTS</b>	
<b>1. PURPOSE</b>	<b>1</b>
<b>2. GENERAL</b>	<b>1</b>
2.1 Provisions for Adults and Children	1
2.2 Equivalent Facilitation	1
2.3 Incorporation by Reference	1A
<b>3. MISCELLANEOUS INSTRUCTIONS AND DEFINITIONS</b>	<b>2</b>
3.1 Graphic Conventions	2
3.2 Dimensional Tolerances	2
3.3 Notes	2
3.4 General Terminology	2
3.5 Definitions	2
<b>4. ACCESSIBLE ELEMENTS AND SPACES: SCOPE AND TECHNICAL REQUIREMENTS</b>	<b>5</b>
4.1 Minimum Requirements	5
4.1.1 Application	5
4.1.2 Accessible Sites and Exterior Facilities: New Construction	6
4.1.3 Accessible Buildings: New Construction	7
4.1.4 (Reserved)	11A
4.1.5 Accessible Buildings: Additions	11A
4.1.6 Accessible Buildings: Alterations	12
4.1.7 Accessible Buildings: Historic Preservation	14
4.2 Space Allowance and Reach Ranges	14A
4.3 Accessible Route	15
4.4 Protruding Objects	21
4.5 Ground and Floor Surfaces	22
4.6 Parking and Passenger Loading Zones	24
4.7 Curb Ramps	26
4.8 Ramps	27
4.9 Stairs	30
4.10 Elevators	30
4.11 Platform Lifts (Wheelchair Lifts)	36
4.12 Windows	36
4.13 Doors	36
4.14 Entrances	40
4.15 Drinking Fountains and Water Coolers	40

4.16	Water Closets . . . . .	40
4.17	Toilet Stalls . . . . .	41A
4.18	Urinals . . . . .	44
4.19	Lavatories and Mirrors . . . . .	44A
4.20	Bathtubs . . . . .	45
4.21	Shower Stalls . . . . .	45
4.22	Toilet Rooms . . . . .	45
4.23	Bathrooms, Bathing Facilities, and Shower Rooms . . . . .	48
4.24	Sinks . . . . .	49
4.25	Storage . . . . .	49
4.26	Handrails, Grab Bars, and Tub and Shower Seats . . . . .	50
4.27	Controls and Operating Mechanisms . . . . .	51
4.28	Alarms . . . . .	52
4.29	Detectable Warnings . . . . .	53
4.30	Signage . . . . .	53
4.31	Telephones . . . . .	54
4.32	Fixed or Built-in Seating and Tables . . . . .	56
4.33	Assembly Areas . . . . .	56
4.34	Automated Teller Machines . . . . .	58
4.35	Dressing, Fitting, and Locker Rooms . . . . .	58A
4.36	Saunas and Steam Rooms . . . . .	58A
4.37	Benches . . . . .	58A
<b>5.</b>	<b>RESTAURANTS AND CAFETERIAS . . . . .</b>	<b>59</b>
<b>6.</b>	<b>MEDICAL CARE FACILITIES . . . . .</b>	<b>60</b>
<b>7.</b>	<b>BUSINESS, MERCANTILE AND CIVIC . . . . .</b>	<b>61</b>
<b>8.</b>	<b>LIBRARIES . . . . .</b>	<b>62</b>
<b>9.</b>	<b>ACCESSIBLE TRANSIENT LODGING . . . . .</b>	<b>63</b>
<b>10.</b>	<b>TRANSPORTATION FACILITIES . . . . .</b>	<b>67</b>
<b>11.</b>	<b>JUDICIAL, LEGISLATIVE AND REGULATORY FACILITIES . . . . .</b>	<b>72</b>
<b>12.</b>	<b>DETENTION AND CORRECTIONAL FACILITIES . . . . .</b>	<b>74</b>
<b>13.</b>	<b>RESIDENTIAL HOUSING (Reserved) . . . . .</b>	<b>76</b>
<b>14.</b>	<b>PUBLIC RIGHTS-OF-WAY (Reserved) . . . . .</b>	<b>76</b>
<b>15.</b>	<b>RECREATION FACILITIES . . . . .</b>	<b>76</b>
	<b>APPENDIX . . . . .</b>	<b>A1</b>

**1. PURPOSE.**

This document contains scoping and technical requirements for accessibility to buildings and facilities by individuals with disabilities under the Americans with Disabilities Act (ADA) of 1990. These scoping and technical requirements are to be applied during the design, construction, and alteration of buildings and facilities covered by titles II and III of the ADA to the extent required by regulations issued by Federal agencies, including the Department of Justice and the Department of Transportation, under the ADA.

The technical requirements in section 4 (Accessible Elements and Spaces: Scope and Technical Requirements), are the same as those of the American National Standard Institute's document A117.1-1980, except as noted in this text by italics. However, the requirements in sections 4.1.1 through 4.1.7 and the special application sections are different from ANSI A117.1-1980 in their entirety and are printed in standard type.

The illustrations and text of ANSI A117.1-1980 are reproduced with permission from the American National Standards Institute. Copies of the

standard may be purchased from the American National Standards Institute at 1430 Broadway, New York, New York 10018.







Paragraphs marked with an asterisk have related, nonmandatory material in the Appendix. In the Appendix, the corresponding paragraph numbers are preceded by an A.

**2. GENERAL.**

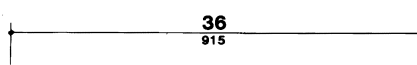
**2.1 Provisions for Adults and Children.** The specifications in these guidelines are based upon adult dimensions and anthropometrics. These guidelines also contain alternate specifications based on children's dimensions and anthropometrics for drinking fountains, water closets, toilet stalls, lavatories, sinks, and fixed or built-in seating and tables.

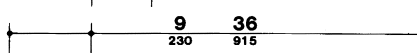
**2.2\* Equivalent Facilitation.** Departures from particular technical and scoping requirements of this guideline by the use of other designs and technologies are permitted where the alternative designs and technologies used will provide substantially equivalent or greater access to and usability of the facility.

**TABLE 1  
Graphic Conventions**

Convention	Description
	Typical dimension line showing U.S. customary units (in inches) above the line and SI units (in millimeters) below
	Dimensions for short distances indicated on extended line
	Dimension line showing alternate dimensions required
	Direction of approach
<b>max</b>	Maximum
<b>min</b>	Minimum
	Boundary of clear floor area
	Centerline

**2.3 Incorporation by Reference**

<p><b>2.3 Incorporation by Reference.</b></p> <p><b>2.3.1 General.</b> The publications listed in 2.3.2 are incorporated by reference in this document. The Director of the Federal Register has approved these materials for incorporation by reference in accordance with 5 U.S.C. 552(a) and 1 CFR part 51. Copies of the referenced publications may be inspected at the Architectural and Transportation Barriers Compliance Board, 1331 F Street, NW., Suite 1000, Washington, DC; at the Department of Justice, Civil Rights Division, Disability Rights Section, 1425 New York Avenue, NW., Washington, DC; or at the Office of the Federal Register, 800 North Capitol Street, NW., Suite 700, Washington, DC.</p> <p><b>2.3.2 Referenced Publications.</b> The specific edition of the publications listed below are referenced in this document. Where differences occur between this document and the referenced publications, this document applies.</p> <p><b>2.3.2.1 American Society for Testing and Materials (ASTM) Standards.</b> Copies of the referenced publications may be obtained from the American Society for Testing and Materials, 100 Bar Harbor Drive, West Conshohocken, Pennsylvania 19428 (<a href="http://www.astm.org">http://www.astm.org</a>).</p> <p>ASTM F 1292-99 Standard Specification for Impact Attenuation of Surface Systems Under and Around Playground Equipment (see 15.6.7.2 Ground Surfaces, Use Zones).</p> <p>ASTM F 1487-98 Standard Consumer Safety Performance Specification for Playground Equipment for Public Use (see 3.5 Definitions, Use Zone).</p> <p>ASTM F 1951-99 Standard Specification for Determination of Accessibility of Surface Systems Under and Around Playground Equipment (see 15.6.7.1 Ground Surfaces, Accessibility).</p> <p><b>2.3.2.2 International Code Council (ICC) Codes.</b> Copies of the referenced publications may be obtained from the International Code Council, 5203 Leesburg Pike, Suite 600, Falls Church, VA 22041-3401 (<a href="http://www.intlcode.org">http://www.intlcode.org</a>).</p>	<p>International Building Code 2000 (see 15.3.3.2 Height).</p>
---	--

1A



**3.0 Miscellaneous Instructions and Definitions**

<p><b>3. MISCELLANEOUS INSTRUCTIONS AND DEFINITIONS.</b></p>	<p><b>3.1 Graphic Conventions.</b> Graphic conventions are shown in Table 1. Dimensions that are not marked minimum or maximum are absolute, unless otherwise indicated in the text or captions.</p> <p><b>3.2 Dimensional Tolerances.</b> All dimensions are subject to conventional building industry tolerances for field conditions.</p> <p><b>3.3 Notes.</b> The text of these guidelines does not contain notes or footnotes. Additional information, explanations, and advisory materials are located in the Appendix.</p> <p><b>3.4 General Terminology.</b></p> <p><u>comply with.</u> Meet one or more specifications of <i>these guidelines</i>.</p> <p><u>if, if ... then.</u> Denotes a specification that applies only when the conditions described are present.</p> <p><u>may.</u> Denotes an option or alternative.</p> <p><u>shall.</u> Denotes a mandatory specification or requirement.</p> <p><u>should.</u> Denotes an advisory specification or recommendation.</p> <p><b>3.5 Definitions.</b></p> <p><b><u>Access Aisle.</u></b> An accessible pedestrian space between elements, such as parking spaces, seating, and desks, that provides clearances appropriate for use of the elements.</p> <p><b><u>Accessible.</u></b> Describes a site, building, facility, or portion thereof that complies with <i>these guidelines</i>.</p> <p><b><u>Accessible Element.</u></b> An <i>element</i> specified by <i>these guidelines</i> (for example, telephone, controls, and the like).</p> <p><b><u>Accessible Route.</u></b> A continuous unobstructed path connecting all accessible elements and spaces of a building or facility. Interior accessible routes may include corridors, floors, ramps, elevators, lifts, and clear floor space at fixtures. Exterior accessible routes may include parking access aisles, curb ramps, <i>crosswalks at vehicular ways</i>, walks, ramps, and lifts.</p> <p><b><u>Accessible Space.</u></b> Space that complies with <i>these guidelines</i>.</p> <p><b><u>Adaptability.</u></b> The ability of certain building spaces and elements, such as kitchen counters, sinks, and grab bars, to be added or altered so as to accommodate the needs of <i>individuals with or without disabilities</i> or to accommodate the needs of persons with different types or degrees of disability.</p> <p><b><u>Addition.</u></b> An <i>expansion, extension, or increase in the gross floor area of a building or facility</i>.</p> <p><b><u>Administrative Authority.</u></b> A governmental agency that adopts or enforces regulations and <i>guidelines</i> for the design, construction, or alteration of buildings and facilities.</p> <p><b><u>Alteration.</u></b> An <i>alteration is a change to a building or facility that affects or could affect the usability of the building or facility or part thereof. Alterations include, but are not limited to, remodeling, renovation, rehabilitation, reconstruction, historic restoration, resurfacing of circulation paths or vehicular ways, changes or rearrangement of the structural parts or elements, and changes or rearrangement in the plan configuration of walls and full-height partitions. Normal maintenance, reroofing, painting or wallpapering, or changes to mechanical and electrical systems are not alterations unless they affect the usability of the building or facility.</i></p> <p><b><u>Amusement Attraction.</u></b> Any facility, or portion of a facility, located within an amusement park</p>
--	--

## 3.5 Definitions

<p>or theme park which provides amusement without the use of an amusement device. Examples include, but are not limited to, fun houses, barrels, and other attractions without seats.</p> <p><b>Amusement Ride.</b> A system that moves persons through a fixed course within a defined area for the purpose of amusement.</p> <p><b>Amusement Ride Seat.</b> A seat that is built-in or mechanically fastened to an amusement ride intended to be occupied by one or more passengers.</p> <p><b>Area of Rescue Assistance.</b> An area, which has direct access to an exit, where people who are unable to use stairs may remain temporarily in safety to await further instructions or assistance during emergency evacuation.</p> <p><b>Area of Sport Activity.</b> That portion of a room or space where the play or practice of a sport occurs.</p> <p><b>Assembly Area.</b> A room or space accommodating a group of individuals for recreational, educational, political, social, civic, or amusement purposes, or for the consumption of food and drink.</p> <p><b>Automatic Door.</b> A door equipped with a power-operated mechanism and controls that open and close the door automatically upon receipt of a momentary actuating signal. The switch that begins the automatic cycle may be a photoelectric device, floor mat, or manual switch (see power-assisted door).</p> <p><b>Boarding Pier.</b> A portion of a pier where a boat is temporarily secured for the purpose of embarking or disembarking.</p> <p><b>Boat Launch Ramp.</b> A sloped surface designed for launching and retrieving trailered boats and other water craft to and from a body of water.</p> <p><b>Boat Slip.</b> That portion of a pier, main pier, finger pier, or float where a boat is moored for</p>	<p>the purpose of berthing, embarking, or disembarking.</p> <p><b>Building.</b> Any structure used and intended for supporting or sheltering any use or occupancy.</p> <p><b>Catch Pool.</b> A pool or designated section of a pool used as a terminus for water slide flumes.</p> <p><b>Circulation Path.</b> An exterior or interior way of passage from one place to another for pedestrians, including, but not limited to, walks, hallways, courtyards, stairways, and stair landings.</p> <p><b>Clear.</b> Unobstructed.</p> <p><b>Clear Floor Space.</b> The minimum unobstructed floor or ground space required to accommodate a single, stationary wheelchair and occupant.</p> <p><b>Closed Circuit Telephone.</b> A telephone with dedicated line(s) such as a house phone, courtesy phone or phone that must be used to gain entrance to a facility.</p> <p><b>Common Use.</b> Refers to those interior and exterior rooms, spaces, or elements that are made available for the use of a restricted group of people (for example, occupants of a homeless shelter, the occupants of an office building, or the guests of such occupants).</p> <p><b>Cross Slope.</b> The slope that is perpendicular to the direction of travel (see running slope).</p> <p><b>Curb Ramp.</b> A short ramp cutting through a curb or built up to it.</p> <p><b>Detectable Warning.</b> A standardized surface feature built in or applied to walking surfaces or other elements to warn visually impaired people of hazards on a circulation path.</p> <p><b>Egress, Means of.</b> A continuous and unobstructed way of exit travel from any point in a building or facility to a public way. A means of egress comprises vertical and horizontal travel and may include intervening room spaces, doorways, hallways, corridors, passageways, balconies, ramps, stairs, enclosures, lobbies,</p>
---	--

**3.5 Definitions**

<p>horizontal exits, courts and yards. An accessible means of egress is one that complies with these guidelines and does not include stairs, steps, or escalators. Areas of rescue assistance or evacuation elevators may be included as part of accessible means of egress.</p> <p><b>Element.</b> An architectural or mechanical component of a building, facility, space, or site, e.g., telephone, curb ramp, door, drinking fountain, seating, or water closet.</p> <p><b>Elevated Play Component.</b> A play component that is approached above or below grade and that is part of a composite play structure consisting of two or more play components attached or functionally linked to create an integrated unit providing more than one play activity.</p> <p><b>Entrance.</b> Any access point to a building or portion of a building or facility used for the purpose of entering. An entrance includes the approach walk, the vertical access leading to the entrance platform, the entrance platform itself, vestibules if provided, the entry door(s) or gate(s) and the hardware of the entry door(s) or gate(s).</p> <p><b>Facility.</b> All or any portion of buildings, structures, site improvements, complexes, equipment, roads, walks, passageways, parking lots, or other real or personal property located on a site.</p> <p><b>Gangway.</b> A variable-sloped pedestrian walkway that links a fixed structure or land with a floating structure. Gangways which connect to vessels are not included.</p> <p><b>Golf Car Passage.</b> A continuous passage on which a motorized golf car can operate.</p> <p><b>Ground Floor.</b> Any occupiable floor less than one story above or below grade with direct access to grade. A building or facility always has at least one ground floor and may have more than one ground floor as where a split level entrance has been provided or where a building is built into a hillside.</p>	<p><b>Ground Level Play Component.</b> A play component that is approached and exited at the ground level.</p> <p><b>Mezzanine or Mezzanine Floor.</b> That portion of a story which is an intermediate floor level placed within the story and having occupiable space above and below its floor.</p> <p><b>Marked Crossing.</b> A crosswalk or other identified path intended for pedestrian use in crossing a vehicular way.</p> <p><b>Multifamily Dwelling.</b> Any building containing more than two dwelling units.</p> <p><b>Occupiable.</b> A room or enclosed space designed for human occupancy in which individuals congregate for amusement, educational or similar purposes, or in which occupants are engaged at labor, and which is equipped with means of egress, light, and ventilation.</p> <p><b>Operable Part.</b> A part of a piece of equipment or appliance used to insert or withdraw objects, or to activate, deactivate, or adjust the equipment or appliance (for example, coin slot, push button, handle).</p> <p><b>Path of Travel.</b> (Reserved).</p> <p><b>Play Area.</b> A portion of a site containing play components designed and constructed for children.</p> <p><b>Play Component.</b> An element intended to generate specific opportunities for play, socialization, or learning. Play components may be manufactured or natural, and may be stand alone or part of a composite play structure.</p> <p><b>Power-assisted Door.</b> A door used for human passage with a mechanism that helps to open the door, or relieves the opening resistance of a door, upon the activation of a switch or a continued force applied to the door itself.</p> <p><b>Private Facility.</b> A place of public accommodation or a commercial facility subject to title III of the ADA and 28 CFR part 36 or a</p>
--	---

## 3.5 Definitions

<p>transportation facility subject to title III of the ADA and 49 CFR 37.45.</p> <p><b>Public Facility.</b> A facility or portion of a facility constructed by, on behalf of, or for the use of a public entity subject to title II of the ADA and 28 CFR part 35 or to title II of the ADA and 49 CFR 37.41 or 37.43.</p> <p><b>Public Use.</b> Describes interior or exterior rooms or spaces that are made available to the general public. Public use may be provided at a building or facility that is privately or publicly owned.</p> <p><b>Ramp.</b> A walking surface which has a running slope greater than 1:20.</p> <p><b>Running Slope.</b> The slope that is parallel to the direction of travel (see cross slope).</p> <p><b>Service Entrance.</b> An entrance intended primarily for delivery of goods or services.</p> <p><b>Signage.</b> Displayed verbal, symbolic, tactile, and pictorial information.</p> <p><b>Site.</b> A parcel of land bounded by a property line or a designated portion of a public right-of-way.</p> <p><b>Site Improvement.</b> Landscaping, paving for pedestrian and vehicular ways, outdoor lighting, recreational facilities, and the like, added to a site.</p> <p><b>Sleeping Accommodations.</b> Rooms in which people sleep; for example, dormitory and hotel or motel guest rooms or suites.</p> <p><b>Soft Contained Play Structure.</b> A play structure made up of one or more components where the user enters a fully enclosed play environment that utilizes pliable materials (e.g., plastic, netting, fabric).</p> <p><b>Space.</b> A definable area, e.g., room, toilet room, hall, assembly area, entrance, storage room, alcove, courtyard, or lobby.</p> <p><b>Story.</b> That portion of a building included between the upper surface of a floor and upper surface of the floor or roof next above. If such portion of a building does not include occupiable</p>	<p>space, it is not considered a story for purposes of these guidelines. There may be more than one floor level within a story as in the case of a mezzanine or mezzanines.</p> <p><b>Structural Frame.</b> The structural frame shall be considered to be the columns and the girders, beams, trusses and spandrels having direct connections to the columns and all other members which are essential to the stability of the building as a whole.</p> <p><b>TDD.</b> (Telecommunication Devices for the Deaf). See text telephone.</p> <p><b>TTY (Tele-Typewriter).</b> See text telephone.</p> <p><b>Tactile.</b> Describes an object that can be perceived using the sense of touch.</p> <p><b>Technically Infeasible.</b> See 4.1.6(1)(j) EXCEPTION.</p> <p><b>Teeing Ground.</b> In golf, the starting place for the hole to be played.</p> <p><b>Text Telephone (TTY).</b> Machinery or equipment that employs interactive text based communications through the transmission of coded signals across the standard telephone network. Text telephones can include, for example, devices known as TDDs (telecommunication display devices or telecommunication devices for deaf persons) or computers with special modems. Text telephones are also called TTYs, an abbreviation for tele-typewriter.</p> <p><b>Transient Lodging.*</b> A building, facility, or portion thereof, excluding inpatient medical care facilities and residential facilities, that contains sleeping accommodations. Transient lodging may include, but is not limited to, resorts, group homes, hotels, motels, and dormitories.</p> <p><b>Transfer Device.</b> Equipment designed to facilitate the transfer of a person from a wheelchair or other mobility device to and from an amusement ride seat.</p>
---	--

**3.5 Definitions**

<p><b>Transition Plate.</b> <i>A sloping pedestrian walking surface located at the end(s) of a gangway.</i></p> <p><b>Use Zone.</b> <i>The ground level area beneath and immediately adjacent to a play structure or equipment that is designated by ASTM F 1487 Standard Consumer Safety Performance Specification for Playground Equipment for Public Use (incorporated by reference, see 2.3.2) for unrestricted circulation around the equipment and on whose surface it is predicted that a user would land when falling from or exiting the equipment.</i></p> <p><b>Vehicular Way.</b> <i>A route intended for vehicular traffic, such as a street, driveway, or parking lot.</i></p> <p><b>Walk.</b> <i>An exterior pathway with a prepared surface intended for pedestrian use, including general pedestrian areas such as plazas and courts.</i></p>	
--	--

4B

**4.0 Accessible Elements and Spaces: Scope and Technical Requirements**

Note: Sections 4.1.1 through 4.1.7 are different from ANSI A117.1 in their entirety and are printed in standard type (ANSI A117.1 does not include scoping provisions).

**4. ACCESSIBLE ELEMENTS AND SPACES: SCOPE AND TECHNICAL REQUIREMENTS.**

**4.1 Minimum Requirements**

**4.1.1\* Application.**

(1) General. All areas of newly designed or newly constructed buildings and facilities and altered portions of existing buildings and facilities shall comply with section 4, unless otherwise provided in this section or as modified in a special application section.

(2) Application Based on Building Use. Special application sections provide additional requirements based on building use. When a building or facility contains more than one use covered by a special application section, each portion shall comply with the requirements for that use.

(3)\* Areas Used Only by Employees as Work Areas. Areas that are used only as work areas shall be designed and constructed so that individuals with disabilities can approach, enter, and exit the areas. These guidelines do not require that any areas used only as work areas be constructed to permit maneuvering within the work area or be constructed or equipped (i.e., with racks or shelves) to be accessible.

(4) Temporary Structures. These guidelines cover temporary buildings or facilities as well as permanent facilities. Temporary buildings and facilities are not of permanent construction but are extensively used or are essential for public use for a period of time. Examples of temporary buildings or facilities covered by these guidelines include, but are not limited to: reviewing stands, temporary classrooms, bleacher areas, exhibit

areas, temporary banking facilities, temporary health screening services, or temporary safe pedestrian passageways around a construction site. Structures, sites and equipment directly associated with the actual processes of construction, such as scaffolding, bridging, materials hoists, or construction trailers are not included.

(5) General Exceptions.

(a) In new construction, a person or entity is not required to meet fully the requirements of these guidelines where that person or entity can demonstrate that it is structurally impracticable to do so. Full compliance will be considered structurally impracticable only in those rare circumstances when the unique characteristics of terrain prevent the incorporation of accessibility features. If full compliance with the requirements of these guidelines is structurally impracticable, a person or entity shall comply with the requirements to the extent it is not structurally impracticable. Any portion of the building or facility which can be made accessible shall comply to the extent that it is not structurally impracticable.

(b) Accessibility is not required to or in:

(i) raised areas used primarily for purposes of security or life or fire safety, including, but not limited to, observation or lookout galleries, prison guard towers, fire towers, or fixed life guard stands;

(ii) non-occupiable spaces accessed only by ladders, catwalks, crawl spaces, very narrow passageways, tunnels, or freight (non-passenger) elevators, and frequented only by service personnel for maintenance, repair, or occasional monitoring of equipment; such spaces may include, but are not limited to, elevator pits, elevator penthouses, piping or equipment catwalks, water or sewage treatment pump rooms and stations, electric substations and transformer vaults, and highway and tunnel utility facilities;

(iii) single occupant structures accessed only by a passageway that is below grade or that is

**4.1.2 Accessible Sites and Exterior Facilities: New Construction**

<p>elevated above standard curb height, including, but not limited to, toll booths accessed from underground tunnels;</p> <p>(iv) raised structures used solely for refereeing, judging, or scoring a sport;</p> <p>(v) water slides;</p> <p>(vi) animal containment areas that are not for public use; or</p> <p>(vii) raised boxing or wrestling rings.</p> <p><b>4.1.2 Accessible Sites and Exterior Facilities: New Construction.</b> An accessible site shall meet the following minimum requirements:</p> <p>(1) At least one accessible route complying with 4.3 shall be provided within the boundary of the site from public transportation stops, accessible parking spaces, passenger loading zones if provided, and public streets or sidewalks, to an accessible building entrance.</p> <p>(2) (a) At least one accessible route complying with 4.3 shall connect accessible buildings, accessible facilities, accessible elements, and accessible spaces that are on the same site.</p> <p>(b)* Court Sports: An accessible route complying with 4.3 shall directly connect both sides of the court in court sports.</p> <p>(3) All objects that protrude from surfaces or posts into circulation paths shall comply with 4.4.</p> <p>EXCEPTION: The requirements of 4.4 shall not apply within an area of sport activity.</p> <p>(4) Ground surfaces along accessible routes and in accessible spaces shall comply with 4.5.</p> <p>EXCEPTION 1*: The requirements of 4.5 shall not apply within an area of sport activity.</p> <p>EXCEPTION 2*: Animal containment areas designed and constructed for public use shall not be required to provide stable, firm, and slip resistant ground and floor surfaces and shall not be required to comply with 4.5.2.</p>	<p>(5) (a) If parking spaces are provided for self-parking by employees or visitors, or both, then accessible spaces complying with 4.6 shall be provided in each such parking area in conformance with the table below. Spaces required by the table need not be provided in the particular lot. They may be provided in a different location if equivalent or greater accessibility, in terms of distance from an accessible entrance, cost and convenience is ensured.</p> <table border="1" style="width: 100%; border-collapse: collapse;"> <thead> <tr> <th style="text-align: center;">TOTAL PARKING IN LOT</th> <th style="text-align: center;">REQUIRED MINIMUM NUMBER OF ACCESSIBLE SPACES</th> </tr> </thead> <tbody> <tr><td style="text-align: center;">1 to 25</td><td style="text-align: center;">1</td></tr> <tr><td style="text-align: center;">26 to 50</td><td style="text-align: center;">2</td></tr> <tr><td style="text-align: center;">51 to 75</td><td style="text-align: center;">3</td></tr> <tr><td style="text-align: center;">76 to 100</td><td style="text-align: center;">4</td></tr> <tr><td style="text-align: center;">101 to 150</td><td style="text-align: center;">5</td></tr> <tr><td style="text-align: center;">151 to 200</td><td style="text-align: center;">6</td></tr> <tr><td style="text-align: center;">201 to 300</td><td style="text-align: center;">7</td></tr> <tr><td style="text-align: center;">301 to 400</td><td style="text-align: center;">8</td></tr> <tr><td style="text-align: center;">401 to 500</td><td style="text-align: center;">9</td></tr> <tr><td style="text-align: center;">501 to 1000</td><td style="text-align: center;">2 percent of total</td></tr> <tr><td style="text-align: center;">1001 and over</td><td style="text-align: center;">20 plus 1 for each 100 over 1000</td></tr> </tbody> </table> <p>Except as provided in (b), access aisles adjacent to accessible spaces shall be 60 in (1525 mm) wide minimum.</p> <p>(b) One in every eight accessible spaces, but not less than one, shall be served by an access aisle 96 in (2440 mm) wide minimum and shall be designated "van accessible" as required by 4.6.4. The vertical clearance at such spaces shall comply with 4.6.5. All such spaces may be grouped on one level of a parking structure.</p> <p>EXCEPTION: Provision of all required parking spaces in conformance with "Universal Parking Design" (see appendix A4.6.3) is permitted.</p> <p>(c) If passenger loading zones are provided, then at least one passenger loading zone shall comply with 4.6.6.</p> <p>(d) At facilities providing medical care and other services for persons with mobility</p>	TOTAL PARKING IN LOT	REQUIRED MINIMUM NUMBER OF ACCESSIBLE SPACES	1 to 25	1	26 to 50	2	51 to 75	3	76 to 100	4	101 to 150	5	151 to 200	6	201 to 300	7	301 to 400	8	401 to 500	9	501 to 1000	2 percent of total	1001 and over	20 plus 1 for each 100 over 1000
TOTAL PARKING IN LOT	REQUIRED MINIMUM NUMBER OF ACCESSIBLE SPACES																								
1 to 25	1																								
26 to 50	2																								
51 to 75	3																								
76 to 100	4																								
101 to 150	5																								
151 to 200	6																								
201 to 300	7																								
301 to 400	8																								
401 to 500	9																								
501 to 1000	2 percent of total																								
1001 and over	20 plus 1 for each 100 over 1000																								

**4.1.3 Accessible Buildings: New Construction**

<p>impairments, parking spaces complying with 4.6 shall be provided in accordance with 4.1.2(5)(a) except as follows:</p> <p>(i) Outpatient units and facilities: 10 percent of the total number of parking spaces provided serving each such outpatient unit or facility;</p> <p>(ii) Units and facilities that specialize in treatment or services for persons with mobility impairments: 20 percent of the total number of parking spaces provided serving each such unit or facility.</p> <p>(e)* Valet parking: Valet parking facilities shall provide a passenger loading zone complying with 4.6.6 located on an accessible route to the entrance of the facility. Paragraphs 5(a), 5(b), and 5(d) of this section do not apply to valet parking facilities.</p> <p>(6) If toilet facilities are provided on a site, then each such public or common use toilet facility shall comply with 4.22. If bathing facilities are provided on a site, then each such public or common use bathing facility shall comply with 4.23.</p> <p>For single user portable toilet or bathing units clustered at a single location, at least five percent but no less than one toilet unit or bathing unit complying with 4.22 or 4.23 shall be installed at each cluster whenever typical inaccessible units are provided. Accessible units shall be identified by the International Symbol of Accessibility.</p> <p>EXCEPTION: Portable toilet units at construction sites used exclusively by construction personnel are not required to comply with 4.1.2(6).</p> <p>(7) Building Signage. Signs which designate permanent rooms and spaces shall comply with 4.30.1, 4.30.4, 4.30.5 and 4.30.6. Other signs which provide direction to, or information about, functional spaces of the building shall comply with 4.30.1, 4.30.2, 4.30.3, and 4.30.5. Elements and spaces of accessible facilities which shall be identified by the International Symbol of</p>	<p>Accessibility and which shall comply with 4.30.7 are:</p> <p>(a) Parking spaces designated as reserved for individuals with disabilities;</p> <p>(b) Accessible passenger loading zones;</p> <p>(c) Accessible entrances when not all are accessible (inaccessible entrances shall have directional signage to indicate the route to the nearest accessible entrance);</p> <p>(d) Accessible toilet and bathing facilities when not all are accessible.</p> <p><b>4.1.3 Accessible Buildings: New Construction.</b> Accessible buildings and facilities shall meet the following minimum requirements:</p> <p>(1) (a) At least one accessible route complying with 4.3 shall connect accessible building or facility entrances with all accessible spaces and elements within the building or facility.</p> <p>(b)* Court Sports: An accessible route complying with 4.3 shall directly connect both sides of the court in court sports.</p> <p>(2) All objects that overhang or protrude into circulation paths shall comply with 4.4.</p> <p>EXCEPTION: The requirements of 4.4 shall not apply within an area of sport activity.</p> <p>(3) Ground and floor surfaces along accessible routes and in accessible rooms and spaces shall comply with 4.5.</p> <p>EXCEPTION 1*: The requirements of 4.5 shall not apply within an area of sport activity.</p> <p>EXCEPTION 2*: Animal containment areas designed and constructed for public use shall not be required to provide stable, firm, and slip resistant ground and floor surfaces and shall not be required to comply with 4.5.2.</p> <p>(4) Interior and exterior stairs connecting levels that are not connected by an elevator, ramp, or</p>
---	--



**4.1.3 Accessible Buildings: New Construction**

<p>other accessible means of vertical access shall comply with 4.9.</p> <p>(5)* One passenger elevator complying with 4.10 shall serve each level, including mezzanines, in all multi-story buildings and facilities unless exempted below. If more than one elevator is provided, each passenger elevator shall comply with 4.10.</p> <p>EXCEPTION 1: Elevators are not required in:</p> <p>(a) private facilities that are less than three stories or that have less than 3000 square feet per story unless the building is a shopping center, a shopping mall, or the professional office of a health care provider, or another type of facility as determined by the Attorney General; or</p> <p>(b) public facilities that are less than three stories and that are not open to the general public if the story above or below the accessible ground floor houses no more than five persons and is less than 500 square feet. Examples may include, but are not limited to, drawbridge towers and boat traffic towers, lock and dam control stations, and train dispatching towers.</p> <p>The elevator exemptions set forth in paragraphs (a) and (b) do not obviate or limit in any way the obligation to comply with the other accessibility requirements established in section 4.1.3. For example, floors above or below the accessible ground floor must meet the requirements of this section except for elevator service. If toilet or bathing facilities are provided on a level not served by an elevator, then toilet or bathing facilities must be provided on the accessible ground floor. In new construction, if a building or facility is eligible for exemption but a passenger elevator is nonetheless planned, that elevator shall meet the requirements of 4.10 and shall serve each level in the building. A passenger elevator that provides service from a garage to only one level of a building or facility is not required to serve other levels.</p> <p>EXCEPTION 2: Elevator pits, elevator penthouses, mechanical rooms, piping or equipment catwalks are exempted from this requirement.</p>	<p>EXCEPTION 3: Accessible ramps complying with 4.8 may be used in lieu of an elevator.</p> <p>EXCEPTION 4: Platform lifts (wheelchair lifts) complying with 4.11 of this guideline and applicable State or local codes may be used in lieu of an elevator only under the following conditions:</p> <p>(a) To provide an accessible route to a performing area in an assembly occupancy.</p> <p>(b) To comply with the wheelchair viewing position line-of-sight and dispersion requirements of 4.33.3.</p> <p>(c) To provide access to incidental occupiable spaces and rooms which are not open to the general public and which house no more than five persons, including but not limited to equipment control rooms and projection booths.</p> <p>(d) To provide access where existing site constraints or other constraints make use of a ramp or an elevator infeasible.</p> <p>(e) To provide access to raised judges' benches, clerks' stations, speakers' platforms, jury boxes and witness stands or to depressed areas such as the well of a court.</p> <p>(f)* To provide access to player seating areas serving an area of sport activity.</p> <p>EXCEPTION 5: Elevators located in air traffic control towers are not required to serve the cab and the floor immediately below the cab.</p> <p>(6) Windows: (Reserved).</p> <p>(7) Doors:</p> <p>(a) At each accessible entrance to a building or facility, at least one door shall comply with 4.13.</p> <p>(b) Within a building or facility, at least one door at each accessible space shall comply with 4.13.</p> <p>(c) Each door that is an element of an accessible route shall comply with 4.13.</p>
---	--

**4.1.3 Accessible Buildings: New Construction**

<p>(d) Each door required by 4.3.10, Egress, shall comply with 4.13.</p> <p>(8)* The requirements in (a) and (b) below shall be satisfied independently:</p> <p>(a)(i) At least 50 percent of all public entrances (excluding those in (b) below) shall comply with 4.14. At least one must be a ground floor entrance. Public entrances are any entrances that are not loading or service entrances.</p> <p>(ii) Accessible public entrances must be provided in a number at least equivalent to the number of exits required by the applicable building or fire codes. (This paragraph does not require an increase in the total number of public entrances planned for a facility.)</p> <p>(iii) An accessible public entrance must be provided to each tenancy in a facility (for example, individual stores in a strip shopping center).</p> <p>(iv) In detention and correctional facilities subject to section 12, public entrances that are secured shall be accessible as required by 12.2.1.</p> <p>One entrance may be considered as meeting more than one of the requirements in (a). Where feasible, accessible public entrances shall be the entrances used by the majority of people visiting or working in the building.</p> <p>(b)(i) In addition, if direct access is provided for pedestrians from an enclosed parking garage to the building, at least one direct entrance from the garage to the building must be accessible.</p> <p>(ii) If access is provided for pedestrians from a pedestrian tunnel or elevated walkway, one entrance to the building from each tunnel or walkway must be accessible.</p> <p>(iii) In judicial, legislative, and regulatory facilities subject to section 11, restricted and secured entrances shall be accessible in the number required by 11.1.1.</p> <p>One entrance may be considered as meeting more than one of the requirements in (b).</p>	<p>Because entrances also serve as emergency exits whose proximity to all parts of buildings and facilities is essential, it is preferable that all entrances be accessible.</p> <p>(c) If the only entrance to a building, or tenancy in a facility, is a service entrance, that entrance shall be accessible.</p> <p>(d) Entrances which are not accessible shall have directional signage complying with 4.30.1, 4.30.2, 4.30.3, and 4.30.5, which indicates the location of the nearest accessible entrance.</p> <p>(9)* In buildings or facilities, or portions of buildings or facilities, required to be accessible, accessible means of egress shall be provided in the same number as required for exits by local building/life safety regulations. Where a required exit from an occupiable level above or below a level of accessible exit discharge is not accessible, an area of rescue assistance shall be provided on each such level (in a number equal to that of inaccessible required exits). Areas of rescue assistance shall comply with 4.3.11. A horizontal exit, meeting the requirements of local building/life safety regulations, shall satisfy the requirement for an area of rescue assistance.</p> <p>EXCEPTION: Areas of rescue assistance are not required in buildings or facilities having a supervised automatic sprinkler system.</p> <p>(10)* Drinking Fountains:</p> <p>(a) Where only one drinking fountain is provided on a floor there shall be a drinking fountain which is accessible to individuals who use wheelchairs in accordance with 4.15 and one accessible to those who have difficulty bending or stooping. (This can be accommodated by the use of a "hi-lo" fountain; by providing one fountain accessible to those who use wheelchairs and one fountain at a standard height convenient for those who have difficulty bending; by providing a fountain accessible under 4.15 and a water cooler; or by such other means as would achieve the required accessibility for each group on each floor.)</p>
---	--

**4.1.3 Accessible Buildings: New Construction**

<p>(b) Where more than one drinking fountain or water cooler is provided on a floor, 50% of those provided shall comply with 4.15 and shall be on an accessible route.</p> <p>(11) Toilet Facilities: If toilet rooms are provided, then each public and common use toilet room shall comply with 4.22. Other toilet rooms provided for the use of occupants of specific spaces (i.e., a private toilet room for the occupant of a private office) shall be adaptable. If bathing rooms are provided, then each public and common use bathroom shall comply with 4.23. Accessible toilet rooms and bathing facilities shall be on an accessible route.</p> <p>(12) Storage, Shelving and Display Units:</p> <p>(a) If fixed or built-in storage facilities such as cabinets, shelves, closets, and drawers are provided in accessible spaces, at least one of each type provided shall contain storage space complying with 4.25. Additional storage may be provided outside of the dimensions required by 4.25.</p> <p>(b) Shelves or display units allowing self-service by customers in mercantile occupancies shall be located on an accessible route complying with 4.3. Requirements for accessible reach range do not apply.</p> <p>(c)* Where lockers are provided in accessible spaces, at least 5 percent, but not less than one, of each type of locker shall comply with 4.25.</p> <p>(13) Controls and operating mechanisms in accessible spaces, along accessible routes, or as parts of accessible elements (for example, light switches and dispenser controls) shall comply with 4.27.</p> <p>EXCEPTION: The requirements of 4.27 shall not apply to exercise machines.</p> <p>(14) If emergency warning systems are provided, then they shall include both audible alarms and visual alarms complying with 4.28. Sleeping accommodations required to comply with 9.3 shall have an alarm system complying</p>	<p>with 4.28. Emergency warning systems in medical care facilities may be modified to suit standard health care alarm design practice.</p> <p>(15) Detectable warnings shall be provided at locations as specified in 4.29.</p> <p>(16) Building Signage:</p> <p>(a) Signs which designate permanent rooms and spaces shall comply with 4.30.1, 4.30.4, 4.30.5 and 4.30.6.</p> <p>(b) Other signs which provide direction to or information about functional spaces of the building shall comply with 4.30.1, 4.30.2, 4.30.3, and 4.30.5.</p> <p>EXCEPTION: Building directories, menus, and all other signs which are temporary are not required to comply.</p> <p>(17) Public Telephones:</p> <p>(a) If public pay telephones, public closed circuit telephones, or other public telephones are provided, then they shall comply with 4.31.2 through 4.31.8 to the extent required by the following table:</p> <table border="1" style="width: 100%; border-collapse: collapse;"> <thead> <tr> <th style="text-align: left;">Number of each type of telephone provided on each floor</th> <th style="text-align: left;">Number of telephones required to comply with 4.31.2 through 4.31.8<sup>1</sup></th> </tr> </thead> <tbody> <tr> <td>1 or more single unit</td> <td>1 per floor</td> </tr> <tr> <td>1 bank<sup>2</sup></td> <td>1 per floor</td> </tr> <tr> <td>2 or more banks<sup>2</sup></td> <td>1 per bank. Accessible unit may be installed as a single unit in proximity (either visible or with signage) to the bank. At least one public telephone per floor shall meet the requirements for a forward reach telephone<sup>3</sup></td> </tr> </tbody> </table> <p><sup>1</sup> Additional public telephones may be installed at any height. Unless otherwise specified, accessible</p>	Number of each type of telephone provided on each floor	Number of telephones required to comply with 4.31.2 through 4.31.8 <sup>1</sup>	1 or more single unit	1 per floor	1 bank <sup>2</sup>	1 per floor	2 or more banks <sup>2</sup>	1 per bank. Accessible unit may be installed as a single unit in proximity (either visible or with signage) to the bank. At least one public telephone per floor shall meet the requirements for a forward reach telephone <sup>3</sup>
Number of each type of telephone provided on each floor	Number of telephones required to comply with 4.31.2 through 4.31.8 <sup>1</sup>								
1 or more single unit	1 per floor								
1 bank <sup>2</sup>	1 per floor								
2 or more banks <sup>2</sup>	1 per bank. Accessible unit may be installed as a single unit in proximity (either visible or with signage) to the bank. At least one public telephone per floor shall meet the requirements for a forward reach telephone <sup>3</sup>								

**4.1.3 Accessible Buildings: New Construction**

<p>telephones may be either forward or side reach telephones.</p> <p><sup>2</sup> A bank consists of two or more adjacent public telephones, often installed as a unit.</p> <p><sup>3</sup> EXCEPTION: For exterior installations only, if dial tone first service is available, then a side reach telephone may be installed instead of the required forward reach telephone.</p> <p>(b)* All telephones required to be accessible and complying with 4.31.2 through 4.31.8 shall be equipped with a volume control. In addition, 25 percent, but never less than one, of all other public telephones provided shall be equipped with a volume control and shall be dispersed among all types of public telephones, including closed circuit telephones, throughout the building or facility. Signage complying with applicable provisions of 4.30.7 shall be provided.</p> <p>(c) The following shall be provided in accordance with 4.31.9:</p> <p>(i) If four or more public pay telephones (including both interior and exterior telephones) are provided at a site of a private facility, and at least one is in an interior location, then at least one interior public text telephone (TTY) shall be provided. If an interior public pay telephone is provided in a public use area in a building of a public facility, at least one interior public text telephone (TTY) shall be provided in the building in a public use area.</p> <p>(ii) If an interior public pay telephone is provided in a private facility that is a stadium or arena, a convention center, a hotel with a convention center, or a covered mall, at least one interior public text telephone (TTY) shall be provided in the facility. In stadiums, arenas and convention centers which are public facilities, at least one public text telephone (TTY) shall be provided on each floor level having at least one interior public pay telephone.</p> <p>(iii) If a public pay telephone is located in or adjacent to a hospital emergency room, hospital recovery room, or hospital waiting room,</p>	<p>one public text telephone (TTY) shall be provided at each such location.</p> <p>(iv) If an interior public pay telephone is provided in the secured area of a detention or correctional facility subject to section 12, then at least one public text telephone (TTY) shall also be provided in at least one secured area. Secured areas are those areas used only by detainees or inmates and security personnel.</p> <p>(d) Where a bank of telephones in the interior of a building consists of three or more public pay telephones, at least one public pay telephone in each such bank shall be equipped with a shelf and outlet in compliance with 4.31.9(2).</p> <p>EXCEPTION: This requirement does not apply to the secured areas of detention or correctional facilities where shelves and outlets are prohibited for purposes of security or safety.</p> <p>(18) If fixed or built-in seating or tables (including, but not limited to, study carrels and student laboratory stations), are provided in accessible public or common use areas, at least five percent (5%), but not less than one, of the fixed or built-in seating areas or tables shall comply with 4.32. An accessible route shall lead to and through such fixed or built-in seating areas, or tables.</p> <p>(19)* Assembly Areas:</p> <p>(a) In places of assembly with fixed seating accessible wheelchair locations shall comply with 4.33.2, 4.33.3, and 4.33.4 and shall be provided consistent with the following table:</p> <table border="1" style="margin-left: auto; margin-right: auto;"> <thead> <tr> <th style="text-align: center;">Capacity of Seating in Assembly Areas</th> <th style="text-align: center;">Number of Required Wheelchair Locations</th> </tr> </thead> <tbody> <tr> <td style="text-align: center;">4 to 25</td> <td style="text-align: center;">1</td> </tr> <tr> <td style="text-align: center;">26 to 50</td> <td style="text-align: center;">2</td> </tr> <tr> <td style="text-align: center;">51 to 300</td> <td style="text-align: center;">4</td> </tr> <tr> <td style="text-align: center;">301 to 500</td> <td style="text-align: center;">6</td> </tr> <tr> <td style="text-align: center;">over 500</td> <td style="text-align: center;">6 plus 1 additional space for each total seating capacity increase of 100</td> </tr> </tbody> </table>	Capacity of Seating in Assembly Areas	Number of Required Wheelchair Locations	4 to 25	1	26 to 50	2	51 to 300	4	301 to 500	6	over 500	6 plus 1 additional space for each total seating capacity increase of 100
Capacity of Seating in Assembly Areas	Number of Required Wheelchair Locations												
4 to 25	1												
26 to 50	2												
51 to 300	4												
301 to 500	6												
over 500	6 plus 1 additional space for each total seating capacity increase of 100												

**4.1.5 Accessible Buildings: Additions**

<p>In addition, one percent, but not less than one, of all fixed seats shall be aisle seats with no armrests on the aisle side, or removable or folding armrests on the aisle side. Each such seat shall be identified by a sign or marker. Signage notifying patrons of the availability of such seats shall be posted at the ticket office. Aisle seats are not required to comply with 4.33.4.</p> <p>(b) This paragraph applies to assembly areas where audible communications are integral to the use of the space (e.g., concert and lecture halls, playhouses and movie theaters, meeting rooms, etc.). Such assembly areas, if (1) they accommodate at least 50 persons, or if they have audio-amplification systems, and (2) they have fixed seating, shall have a permanently installed assistive listening system complying with 4.33. For other assembly areas, a permanently installed assistive listening system, or an adequate number of electrical outlets or other supplementary wiring necessary to support a portable assistive listening system shall be provided. The minimum number of receivers to be provided shall be equal to 4 percent of the total number of seats, but in no case less than two. Signage complying with applicable provisions of 4.30 shall be installed to notify patrons of the availability of a listening system.</p> <p>(c) Where a team or player seating area contains fixed seats and serves an area of sport activity, the seating area shall contain the number of wheelchair spaces required by 4.1.3(19)(a), but not less than one wheelchair space. Wheelchair spaces shall comply with 4.33.2, 4.33.3, 4.33.4, and 4.33.5.</p> <p>EXCEPTION 1: Wheelchair spaces in team or player seating areas shall not be required to provide a choice of admission price or lines of sight comparable to those for members of the general public.</p> <p>EXCEPTION 2: This provision shall not apply to team or player seating areas serving bowling lanes not required to be accessible by 15.7.2.</p> <p>(20) Where automated teller machines (ATMs) are provided, each ATM shall comply with the</p>	<p>requirements of 4.34 except where two or more are provided at a location, then only one must comply.</p> <p>EXCEPTION: Drive-up-only automated teller machines are not required to comply with 4.27.2, 4.27.3 and 4.34.3.</p> <p>(21) Where dressing, fitting, or locker rooms are provided, the rooms shall comply with 4.35.</p> <p>EXCEPTION: Where dressing, fitting, or locker rooms are provided in a cluster, at least 5 percent, but not less than one, of the rooms for each type of use in each cluster shall comply with 4.35.</p> <p>(22) Where saunas or steam rooms are provided, the rooms shall comply with 4.36.</p> <p>EXCEPTION: Where saunas or steam rooms are provided in a cluster, at least 5 percent, but not less than one, of the rooms for each type of use in each cluster shall comply with 4.36.</p> <p><b>4.1.4 (Reserved)</b></p> <p><b>4.1.5 Accessible Buildings: Additions.</b> Each addition to an existing building or facility shall be regarded as an alteration. Each space or element added to the existing building or facility shall comply with the applicable provisions of 4.1.1 to 4.1.3, Minimum Requirements (for New Construction) and the applicable technical specifications of section 4 and the special application sections. Each addition that affects or could affect the usability of an area containing a primary function shall comply with 4.1.6(2).</p>
--	---

11A

**4.1.6 Accessible Buildings: Alterations**

<p><b>4.1.6 Accessible Buildings: Alterations.</b></p> <p>(1) General. Alterations to existing buildings and facilities shall comply with the following:</p> <p>(a) No alteration shall be undertaken which decreases or has the effect of decreasing accessibility or usability of a building or facility below the requirements for new construction at the time of alteration.</p> <p>(b) If existing elements, spaces, or common areas are altered, then each such altered element, space, feature, or area shall comply with the applicable provisions of 4.1.1 to 4.1.3 Minimum Requirements (for New Construction). If the applicable provision for new construction requires that an element, space, or common area be on an accessible route, the altered element, space, or common area is not required to be on an accessible route except as provided in 4.1.6(2) (Alterations to an Area Containing a Primary Function).</p> <p>(c) If alterations of single elements, when considered together, amount to an alteration of a room or space in a building or facility, the entire space shall be made accessible.</p> <p>(d) No alteration of an existing element, space, or area of a building or facility shall impose a requirement for greater accessibility than that which would be required for new construction. For example, if the elevators and stairs in a building are being altered and the elevators are, in turn, being made accessible, then no accessibility modifications are required to the stairs connecting levels connected by the elevator. If stair modifications to correct unsafe conditions are required by other codes, the modifications shall be done in compliance with these guidelines unless technically infeasible.</p> <p>(e) At least one interior public text telephone (TTY) complying with 4.31.9 shall be provided if:</p> <p>(i) alterations to existing buildings or facilities with less than four exterior or interior public pay telephones would increase the total number to four or more telephones with at least one in an interior location; or</p>	<p>(ii) alterations to one or more exterior or interior public pay telephones occur in an existing building or facility with four or more public telephones with at least one in an interior location.</p> <p>(f) If an escalator or stair is planned or installed where none existed previously and major structural modifications are necessary for such installation, then a means of accessible vertical access shall be provided that complies with the applicable provisions of 4.7, 4.8, 4.10, or 4.11.</p> <p>(g) In alterations, the requirements of 4.1.3(9), 4.3.10 and 4.3.11 do not apply.</p> <p>(h)* Entrances. If a planned alteration entails alterations to an entrance, and the building has an accessible entrance, the entrance being altered is not required to comply with 4.1.3(8), except to the extent required by 4.1.6(2). If a particular entrance is not made accessible, appropriate accessible signage indicating the location of the nearest accessible entrance(s) shall be installed at or near the inaccessible entrance, such that a person with disabilities will not be required to retrace the approach route from the inaccessible entrance.</p> <p>(i) If the alteration work is limited solely to the electrical, mechanical, or plumbing system, or to hazardous material abatement, or automatic sprinkler retrofitting, and does not involve the alteration of any elements or spaces required to be accessible under these guidelines, then 4.1.6(2) does not apply.</p> <p>(j) EXCEPTION: In alteration work, if compliance with 4.1.6 is technically infeasible, the alteration shall provide accessibility to the maximum extent feasible. Any elements or features of the building or facility that are being altered and can be made accessible shall be made accessible within the scope of the alteration.</p> <p><b>Technically Infeasible.</b> Means, with respect to an alteration of a building or a facility, that it has little likelihood of being accomplished because existing structural conditions would require removing or altering a load-bearing member which is an essential part of the structural frame; or because other</p>
---	---

**4.1.6 Accessible Buildings: Alterations**

<p>existing physical or site constraints prohibit modification or addition of elements, spaces, or features which are in full and strict compliance with the minimum requirements for new construction and which are necessary to provide accessibility.</p> <p>(k) EXCEPTION:</p> <p>(i) These guidelines do not require the installation of an elevator in an altered facility that is exempt from the requirement for an elevator under 4.1.3(5).</p> <p>(ii) The exemption provided in paragraph (i) does not obviate or limit in any way the obligation to comply with the other accessibility requirements established in these guidelines. For example, alterations to floors above or below the ground floor must be accessible regardless of whether the altered facility has an elevator. If a facility subject to the elevator exemption set forth in paragraph (i) nonetheless has a passenger elevator, that elevator shall meet, to the maximum extent feasible, the accessibility requirements of these guidelines.</p> <p>(2) Alterations to an Area Containing a Primary Function. In addition to the requirements of 4.1.6(1), an alteration that affects or could affect the usability of or access to an area containing a primary function shall be made so as to ensure that, to the maximum extent feasible, the path of travel to the altered area and the restrooms, telephones, and drinking fountains serving the altered area, are readily accessible to and usable by individuals with disabilities, unless such alterations are disproportionate to the overall alterations in terms of cost and scope (as determined under criteria established by the Attorney General).</p> <p>(3) Special Technical Provisions for Alterations to Existing Buildings and Facilities.</p> <p>(a) Ramps. Curb ramps and interior or exterior ramps to be constructed on sites or in existing buildings or facilities where space limitations prohibit the use of a 1:12 slope or less may have slopes and rises as follows:</p> <p>(i) A slope between 1:10 and 1:12 is allowed for a maximum rise of 6 in (152 mm).</p>	<p>(ii) A slope between 1:8 and 1:10 is allowed for a maximum rise of 3 in (76 mm). A slope steeper than 1:8 is not allowed.</p> <p>(b) Stairs. Full extension of handrails at stairs shall not be required in alterations where such extensions would be hazardous or impossible due to plan configuration.</p> <p>(c) Elevators.</p> <p>(i) If safety door edges are provided in existing automatic elevators, automatic door reopening devices may be omitted (see 4.10.6).</p> <p>(ii) Where existing shaft configuration or technical infeasibility prohibits strict compliance with 4.10.9, the minimum car plan dimensions may be reduced by the minimum amount necessary, but in no case shall the inside car area be smaller than 48 in by 48 in (1220 mm by 1220 mm).</p> <p>(iii) Equivalent facilitation may be provided with an elevator car of different dimensions when usability can be demonstrated and when all other elements required to be accessible comply with the applicable provisions of 4.10. For example, an elevator of 47 in by 69 in (1195 mm by 1755 mm) with a door opening on the narrow dimension, could accommodate the standard wheelchair clearances shown in Fig. 4.</p> <p>(d) Doors.</p> <p>(i) Where it is technically infeasible to comply with clear opening width requirements of 4.13.5, a projection of 5/8 in (16 mm) maximum will be permitted for the latch side stop.</p> <p>(ii) If existing thresholds are 3/4 in (20 mm) high or less, and have (or are modified to have) a beveled edge on each side, they may remain.</p> <p>(e) Toilet Rooms.</p> <p>(i) Where it is technically infeasible to comply with 4.22 or 4.23, the installation of at least one unisex toilet/bathroom per floor, located in the same area as existing toilet facilities, will be permitted in lieu of modifying existing toilet facilities to be accessible. Each unisex toilet room shall contain one water closet complying with 4.16 and one lavatory complying with 4.19, and the door shall have a privacy latch.</p>
--	---

**4.1.7 Accessible Buildings: Historic Preservation**

<p>(ii) Where it is technically infeasible to install a required standard stall (Fig. 30(a)), or where other codes prohibit reduction of the fixture count (i.e., removal of a water closet in order to create a double-wide stall), either alternate stall (Fig. 30(b)) may be provided in lieu of the standard stall.</p> <p>(iii) When existing toilet or bathing facilities are being altered and are not made accessible, signage complying with 4.30.1, 4.30.2, 4.30.3, 4.30.5, and 4.30.7 shall be provided indicating the location of the nearest accessible toilet or bathing facility within the facility.</p> <p>(f) Assembly Areas.</p> <p>(i) Where it is technically infeasible to disperse accessible seating throughout an altered assembly area, accessible seating areas may be clustered. Each accessible seating area shall have provisions for companion seating and shall be located on an accessible route that also serves as a means of emergency egress.</p> <p>(ii) Where it is technically infeasible to alter all performing areas to be on an accessible route, at least one of each type of performing area shall be made accessible.</p> <p>(g) Platform Lifts (Wheelchair Lifts). In alterations, platform lifts (wheelchair lifts) complying with 4.11 and applicable state or local codes may be used as part of an accessible route. The use of lifts is not limited to the five conditions in Exception 4 of 4.1.3(5).</p> <p>(h) Dressing Rooms. In alterations where technical infeasibility can be demonstrated, one dressing room for each sex on each level shall be made accessible. Where only unisex dressing rooms are provided, accessible unisex dressing rooms may be used to fulfill this requirement.</p> <p><b>4.1.7 Accessible Buildings: Historic Preservation.</b></p> <p>(1)* Applicability.</p> <p>(a) General Rule. Alterations to a qualified historic building or facility shall comply with 4.1.6 (Accessible Buildings: Alterations), the applicable technical specifications of section 4 and the applicable special application sections unless it is determined in accordance</p>	<p>with the procedures in 4.1.7(2) that compliance with the requirements for accessible routes (exterior and interior), ramps, entrances, or toilets would threaten or destroy the historic significance of the building or facility in which case the alternative requirements in 4.1.7(3) may be used for the feature.</p> <p>(b) Definition. A qualified historic building or facility is a building or facility that is:</p> <p>(i) Listed in or eligible for listing in the National Register of Historic Places; or</p> <p>(ii) Designated as historic under an appropriate State or local law.</p> <p>(2) Procedures.</p> <p>(a) Alterations to Qualified Historic Buildings and Facilities Subject to Section 106 of the National Historic Preservation Act.</p> <p>(i) Section 106 Process. Section 106 of the National Historic Preservation Act (16 U.S.C. 470f) requires that a Federal agency with jurisdiction over a Federal, federally assisted, or federally licensed undertaking consider the effects of the agency's undertaking on buildings and facilities listed in or eligible for listing in the National Register of Historic Places and give the Advisory Council on Historic Preservation a reasonable opportunity to comment on the undertaking prior to approval of the undertaking.</p> <p>(ii) ADA Application. Where alterations are undertaken to a qualified historic building or facility that is subject to section 106 of the National Historic Preservation Act, the Federal agency with jurisdiction over the undertaking shall follow the section 106 process. If the State Historic Preservation Officer or Advisory Council on Historic Preservation agrees that compliance with the requirements for accessible routes (exterior and interior), ramps, entrances, or toilets would threaten or destroy the historic significance of the building or facility, the alternative requirements in 4.1.7(3) may be used for the feature.</p> <p>(b) Alterations to Qualified Historic Buildings and Facilities Not Subject to Section 106 of the National Historic Preservation Act. Where alterations are undertaken to a qualified historic building or facility that is not subject to section 106 of the National Historic</p>
--	--



**4.2 Space Allowance and Reach Ranges**

<p>Preservation Act, if the entity undertaking the alterations believes that compliance with the requirements for accessible routes (exterior and interior), ramps, entrances, or toilets would threaten or destroy the historic significance of the building or facility and that the alternative requirements in 4.1.7(3) should be used for the feature, the entity should consult with the State Historic Preservation Officer. If the State Historic Preservation Officer agrees that compliance with the accessibility requirements for accessible routes (exterior and interior), ramps, entrances or toilets would threaten or destroy the historical significance of the building or facility, the alternative requirements in 4.1.7(3) may be used.</p> <p>(c) Consultation With Interested Persons. Interested persons should be invited to participate in the consultation process, including State or local accessibility officials, individuals with disabilities, and organizations representing individuals with disabilities.</p> <p>(d) Certified Local Government Historic Preservation Programs. Where the State Historic Preservation Officer has delegated the consultation responsibility for purposes of this section to a local government historic preservation program that has been certified in accordance with section 101(c) of the National Historic Preservation Act of 1966 (16 U.S.C. 470a (c)) and implementing regulations (36 CFR 61.5), the responsibility may be carried out by the appropriate local government body or official.</p> <p>(3) Historic Preservation: Minimum Requirements.</p> <p>(a) At least one accessible route complying with 4.3 from a site access point to an accessible entrance shall be provided.</p> <p>EXCEPTION: A ramp with a slope no greater than 1:6 for a run not to exceed 2 ft (610 mm) may be used as part of an accessible route to an entrance.</p> <p>(b) At least one accessible entrance complying with 4.14 which is used by the public shall be provided.</p> <p>EXCEPTION: If it is determined that no entrance used by the public can comply with 4.14, then access at any entrance not used by the general public but open (unlocked) with directional signage at the primary entrance</p>	<p>may be used. The accessible entrance shall also have a notification system. Where security is a problem, remote monitoring may be used.</p> <p>(c) If toilets are provided, then at least one toilet facility complying with 4.22 and 4.1.6 shall be provided along an accessible route that complies with 4.3. Such toilet facility may be unisex in design.</p> <p>(d) Accessible routes from an accessible entrance to all publicly used spaces on at least the level of the accessible entrance shall be provided. Access shall be provided to all levels of a building or facility in compliance with 4.1 whenever practical.</p> <p>(e) Displays and written information, documents, etc., should be located where they can be seen by a seated person. Exhibits and signage displayed horizontally (e.g., open books), should be no higher than 44 in (1120 mm) above the floor surface.</p> <p>NOTE: The technical provisions of sections 4.2 through 4.35 are the same as those of the American National Standard Institute's document A117.1-1980, except as noted in the text.</p> <p><b>4.2 Space Allowance and Reach Ranges.</b></p> <p><b>4.2.1* Wheelchair Passage Width.</b> The minimum clear width for single wheelchair passage shall be 32 in (815 mm) at a point and 36 in (915 mm) continuously (see Fig. 1 and 24(e)).</p> <p><b>4.2.2 Width for Wheelchair Passing.</b> The minimum width for two wheelchairs to pass is 60 in (1525 mm) (see Fig. 2).</p> <p><b>4.2.3* Wheelchair Turning Space.</b> The space required for a wheelchair to make a 180-degree turn is a clear space of 60 in (1525 mm) diameter (see Fig. 3(a)) or a T-shaped space (see Fig. 3(b)).</p>
--	--

**4.2.4\* Clear Floor or Ground Space for Wheelchairs**

**4.2.4\* Clear Floor or Ground Space for Wheelchairs.**

**4.2.4.1 Size and Approach.** The minimum clear floor or ground space required to accommodate a single, stationary wheelchair and occupant is 30 in by 48 in (760 mm by 1220 mm) (see Fig. 4(a)). The minimum clear floor or ground space for wheelchairs may be positioned for forward or parallel approach to an object (see Fig. 4(b) and (c)). Clear floor or ground space for wheelchairs may be part of the knee space required under some objects.

**4.2.4.2 Relationship of Maneuvering Clearance to Wheelchair Spaces.** One full unobstructed side of the clear floor or ground space for a wheelchair shall adjoin or overlap an accessible route or adjoin another wheelchair clear floor space. If a clear floor space is located in an alcove or otherwise confined on all or part of three sides, additional maneuvering clearances shall be provided as shown in Fig. 4(d) and (e).

**4.2.4.3 Surfaces for Wheelchair Spaces.** Clear floor or ground spaces for wheelchairs shall comply with 4.5.

**4.2.5\* Forward Reach.** If the clear floor space only allows forward approach to an object, the maximum high forward reach allowed shall be 48 in (1220 mm) (see Fig. 5(a)). *The minimum low forward reach is 15 in (380 mm).* If the high forward reach is over an obstruction, reach and clearances shall be as shown in Fig. 5(b).

**4.2.6\* Side Reach.** If the clear floor space allows parallel approach by a person in a wheelchair, the maximum high side reach allowed shall be 54 in (1370 mm) and the low side reach shall be no less than 9 in (230 mm) above the floor (Fig. 6(a) and (b)). If the side reach is over an obstruction, the reach and clearances shall be as shown in Fig. 6(c).

**4.3 Accessible Route.**

**4.3.1\* General.** All walks, halls, corridors, aisles, *skywalks*, *tunnels*, and other spaces

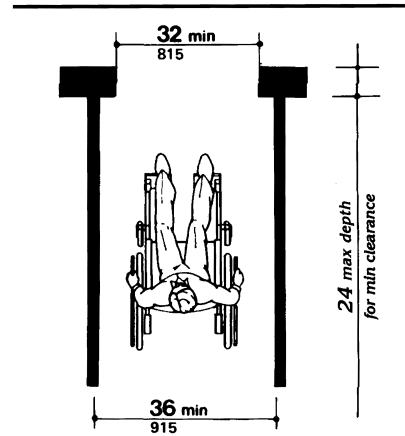

Fig. 1  
Minimum Clear Width  
for Single Wheelchair

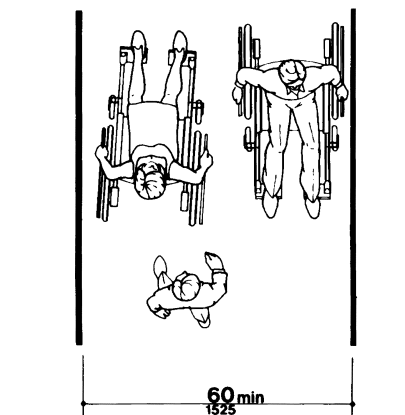

Fig. 2  
Minimum Clear Width  
for Two Wheelchairs

**4.3 Accessible Route**

that are part of an accessible route shall comply with 4.3.

**4.3.2 Location.**

(1) At least one accessible route *within the boundary of the site* shall be provided from public transportation stops, accessible parking, and accessible passenger loading zones, and public streets or sidewalks to the accessible building entrance they serve. *The accessible route shall, to the maximum extent feasible, coincide with the route for the general public.*

(2) At least one accessible route shall connect accessible buildings, facilities, elements, and spaces that are on the same site.

(3) At least one accessible route shall connect accessible building or facility entrances with all accessible spaces and elements and with all accessible dwelling units within the building or facility.

(4) An accessible route shall connect at least one accessible entrance of each accessible

dwelling unit with those exterior and interior spaces and facilities that serve the accessible dwelling unit.

**4.3.3 Width.** The minimum clear width of an accessible route shall be 36 in (915 mm) except at doors (see 4.13.5 and 4.13.6). If a person in a wheelchair must make a turn around an obstruction, the minimum clear width of the accessible route shall be as shown in Fig. 7(a) and (b).

**4.3.4 Passing Space.** If an accessible route has less than 60 in (1525 mm) clear width, then passing spaces at least 60 in by 60 in (1525 mm by 1525 mm) shall be located at reasonable intervals not to exceed 200 ft (61 m). A T-intersection of two corridors or walks is an acceptable passing place.

**4.3.5 Head Room.** Accessible routes shall comply with 4.4.2.

**4.3.6 Surface Textures.** The surface of an accessible route shall comply with 4.5.

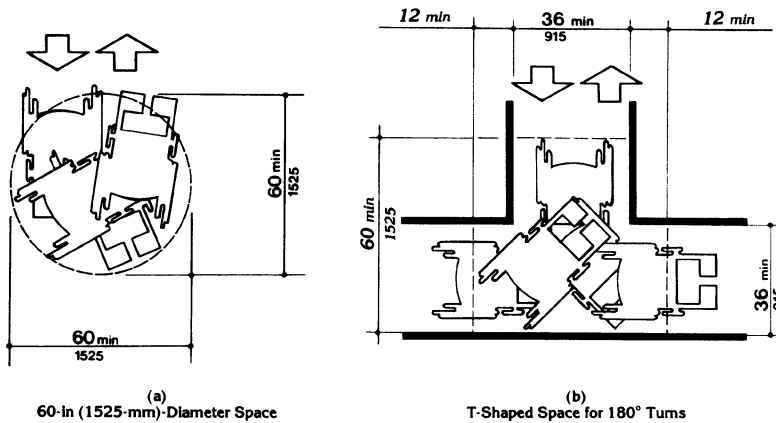
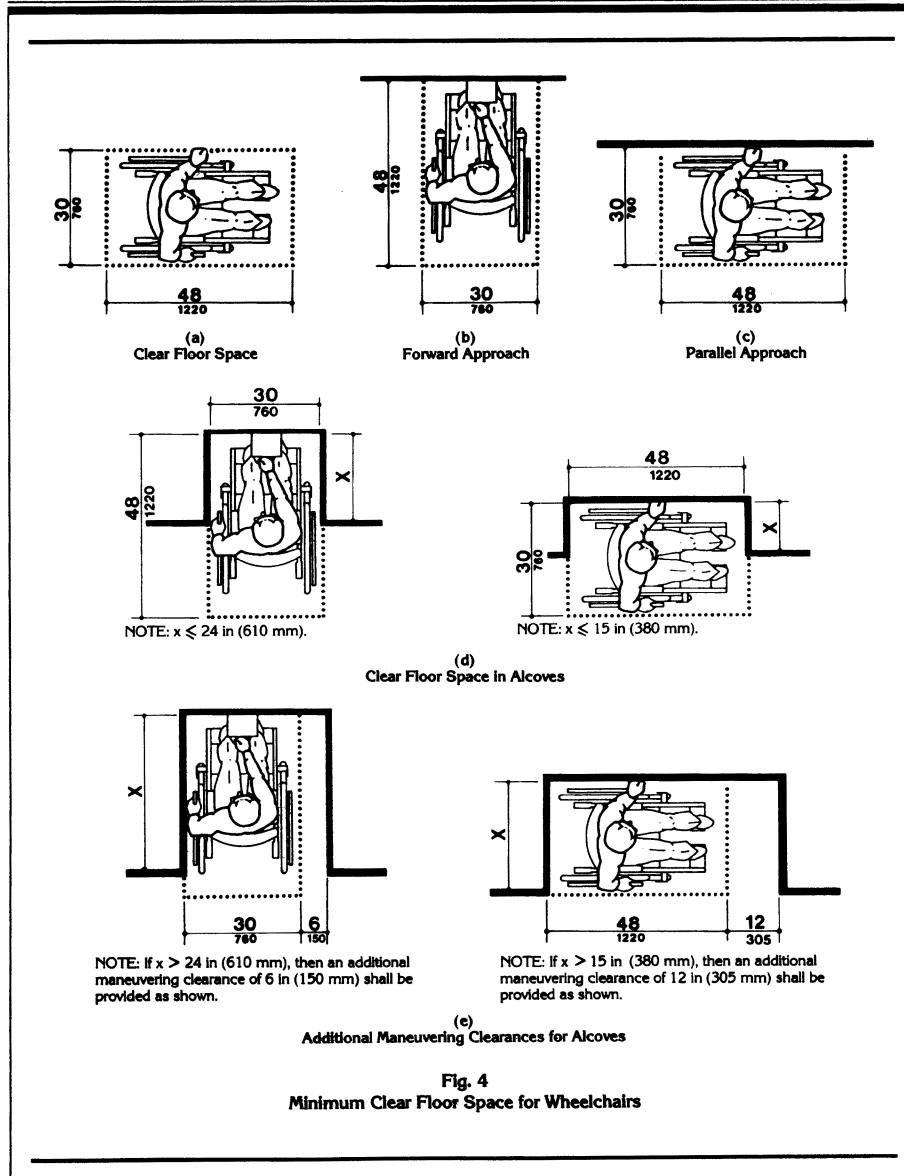
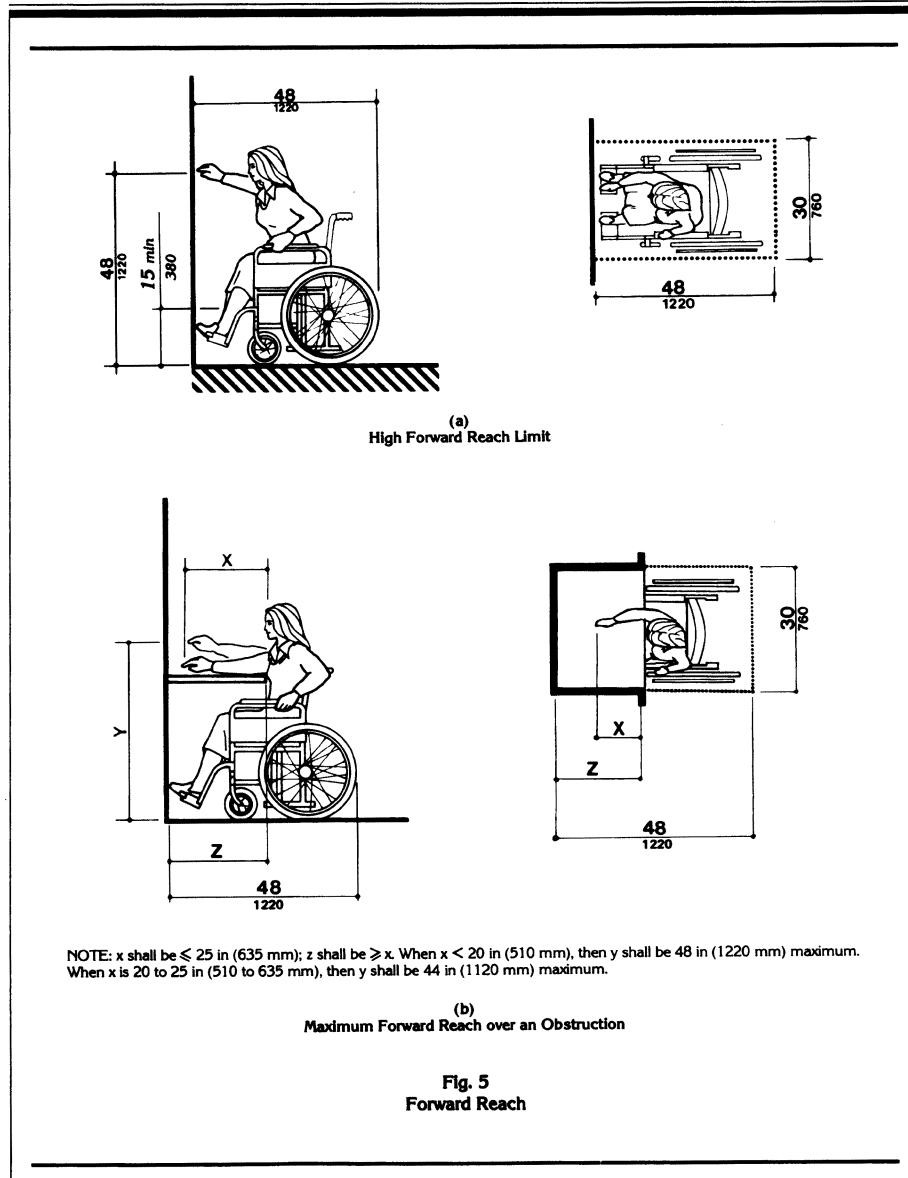

Fig. 3  
Wheelchair Turning Space

4.3 Accessible Route



4.3 Accessible Route



4.3.7 Slope

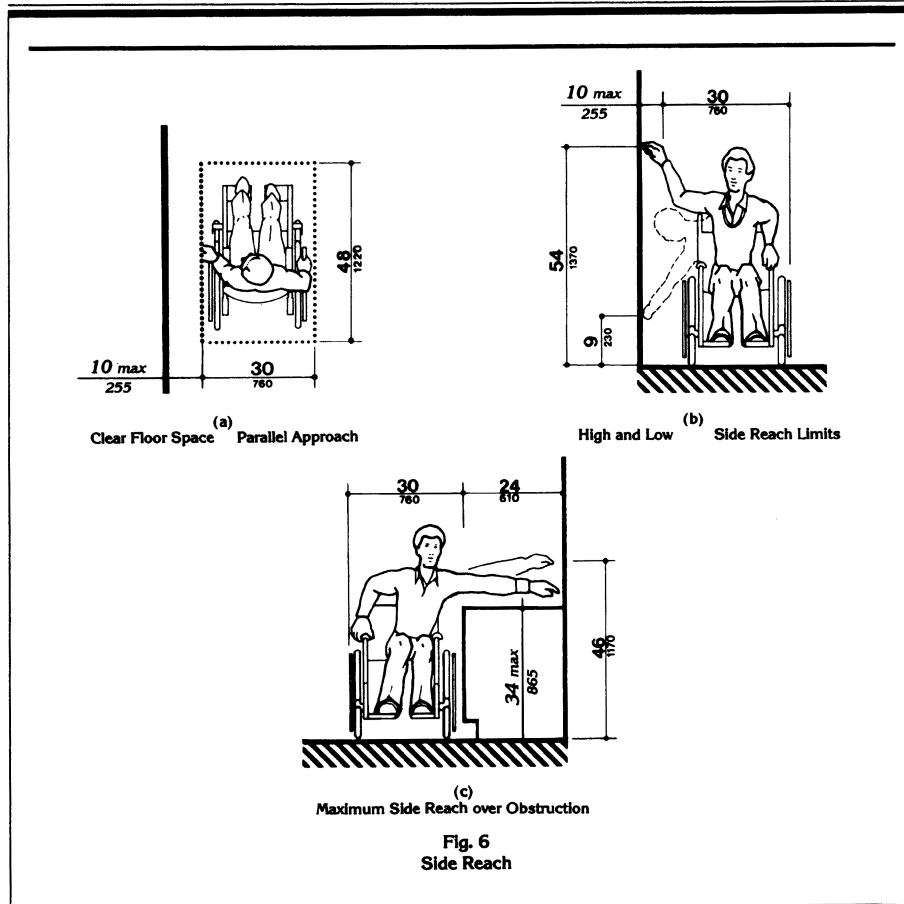

**4.3.7 Slope.** An accessible route with a running slope greater than 1:20 is a ramp and shall comply with 4.8. Nowhere shall the cross slope of an accessible route exceed 1:50.

**4.3.8 Changes in Levels.** Changes in levels along an accessible route shall comply with 4.5.2. If an accessible route has changes in level greater than 1/2 in (13 mm), then a curb

ramp, ramp, elevator, or platform lift (as permitted in 4.1.3 and 4.1.6) shall be provided that complies with 4.7, 4.8, 4.10, or 4.11, respectively. An accessible route does not include stairs, steps, or escalators. See definition of "egress, means of" in 3.5.

**4.3.9 Doors.** Doors along an accessible route shall comply with 4.13.

**4.3.10\* Egress**

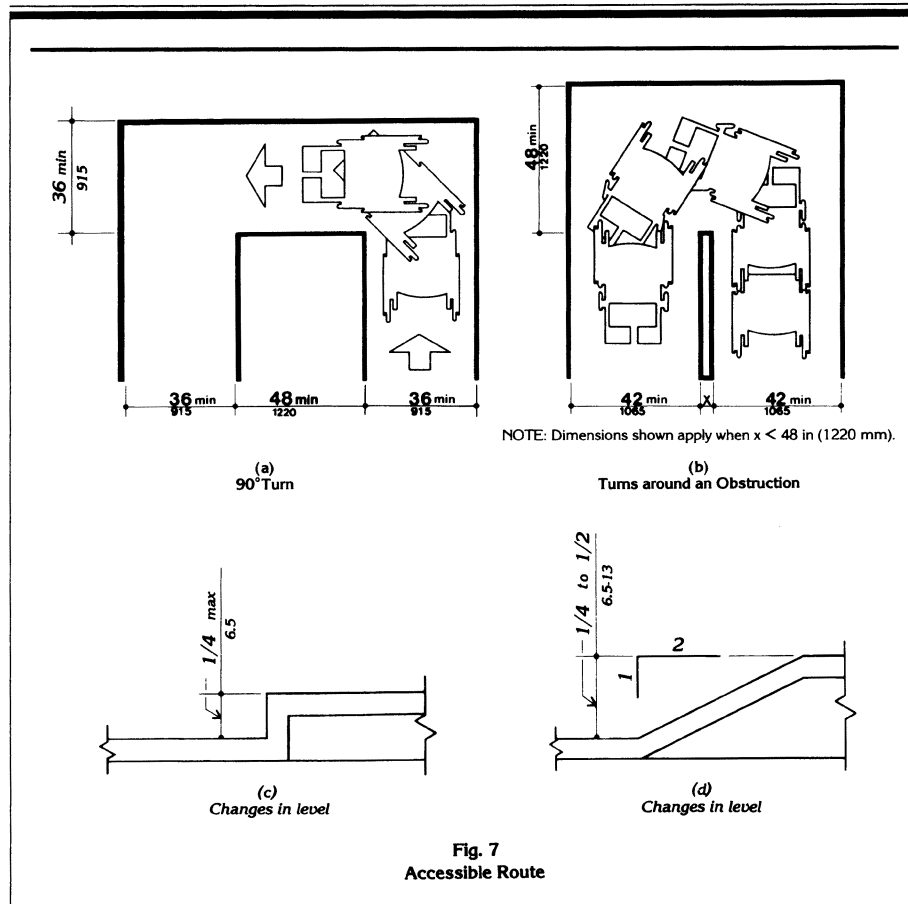

**Fig. 7**  
**Accessible Route**

**4.3.10\* Egress.** Accessible routes serving any accessible space or element shall also serve as a means of egress for emergencies or connect to an accessible area of rescue assistance.

**4.3.11 Areas of Rescue Assistance.**

**4.3.11.1 Location and Construction.** An area of rescue assistance shall be one of the following:

(1) A portion of a stairway landing within a smokeproof enclosure (complying with local requirements).

(2) A portion of an exterior exit balcony located immediately adjacent to an exit stairway when the balcony complies with local requirements for exterior exit balconies. Openings to the interior of the building located within 20 feet (6 m) of the

**4.4 Protruding Objects**

<p>area of rescue assistance shall be protected with fire assemblies having a three-fourths hour fire protection rating.</p> <p>(3) A portion of a one-hour fire-resistive corridor (complying with local requirements for fire-resistive construction and for openings) located immediately adjacent to an exit enclosure.</p> <p>(4) A vestibule located immediately adjacent to an exit enclosure and constructed to the same fire-resistive standards as required for corridors and openings.</p> <p>(5) A portion of a stairway landing within an exit enclosure which is vented to the exterior and is separated from the interior of the building with not less than one-hour fire-resistive doors.</p> <p>(6) When approved by the appropriate local authority, an area or a room which is separated from other portions of the building by a smoke barrier. Smoke barriers shall have a fire-resistive rating of not less than one hour and shall completely enclose the area or room. Doors in the smoke barrier shall be tight-fitting smoke and draft-control assemblies having a fire-protection rating of not less than 20 minutes and shall be self-closing or automatic closing. The area or room shall be provided with an exit directly to an exit enclosure. Where the room or area exits into an exit enclosure which is required to be of more than one-hour fire-resistive construction, the room or area shall have the same fire-resistive construction, including the same opening protection, as required for the adjacent exit enclosure.</p> <p>(7) An elevator lobby when elevator shafts and adjacent lobbies are pressurized as required for smokeproof enclosures by local regulations and when complying with requirements herein for size, communication, and signage. Such pressurization system shall be activated by smoke detectors on each floor located in a manner approved by the appropriate local authority. Pressurization equipment and its duct work within the building shall be separated from other portions of the building by a minimum two-hour fire-resistive construction.</p> <p><b>4.3.11.2 Size.</b> Each area of rescue assistance shall provide at least two accessible areas each being not less than 30 inches by 48 inches (760 mm by 1220 mm). The area of rescue</p>	<p>assistance shall not encroach on any required exit width. The total number of such 30-inch by 48-inch (760 mm by 1220 mm) areas per story shall be not less than one for every 200 persons of calculated occupant load served by the area of rescue assistance.</p> <p><b>EXCEPTION:</b> The appropriate local authority may reduce the minimum number of 30-inch by 48-inch (760 mm by 1220 mm) areas to one for each area of rescue assistance on floors where the occupant load is less than 200.</p> <p><b>4.3.11.3* Stairway Width.</b> Each stairway adjacent to an area of rescue assistance shall have a minimum clear width of 48 inches between handrails.</p> <p><b>4.3.11.4* Two-way Communication.</b> A method of two-way communication, with both visible and audible signals, shall be provided between each area of rescue assistance and the primary entry. The fire department or appropriate local authority may approve a location other than the primary entry.</p> <p><b>4.3.11.5 Identification.</b> Each area of rescue assistance shall be identified by a sign which states "AREA OF RESCUE ASSISTANCE" and displays the international symbol of accessibility. The sign shall be illuminated when exit sign illumination is required. Signage shall also be installed at all inaccessible exits and where otherwise necessary to clearly indicate the direction to areas of rescue assistance. In each area of rescue assistance, instructions on the use of the area under emergency conditions shall be posted adjoining the two-way communication system.</p> <p><b>4.4 Protruding Objects.</b></p> <p><b>4.4.1* General.</b> Objects projecting from walls (for example, telephones) with their leading edges between 27 in and 80 in (685 mm and 2030 mm) above the finished floor shall protrude no more than 4 in (100 mm) into walks, halls, corridors, passageways, or aisles (see Fig. 8(a)). Objects mounted with their leading edges at or below 27 in (685 mm) above the finished floor may protrude any amount (see Fig. 8(a) and (b)). Free-standing objects mounted on posts or pylons may overhang 12 in (305 mm) maximum from 27 in to 80 in (685 mm to 2030 mm) above the ground or</p>
---	---



**4.4 Protruding Objects**

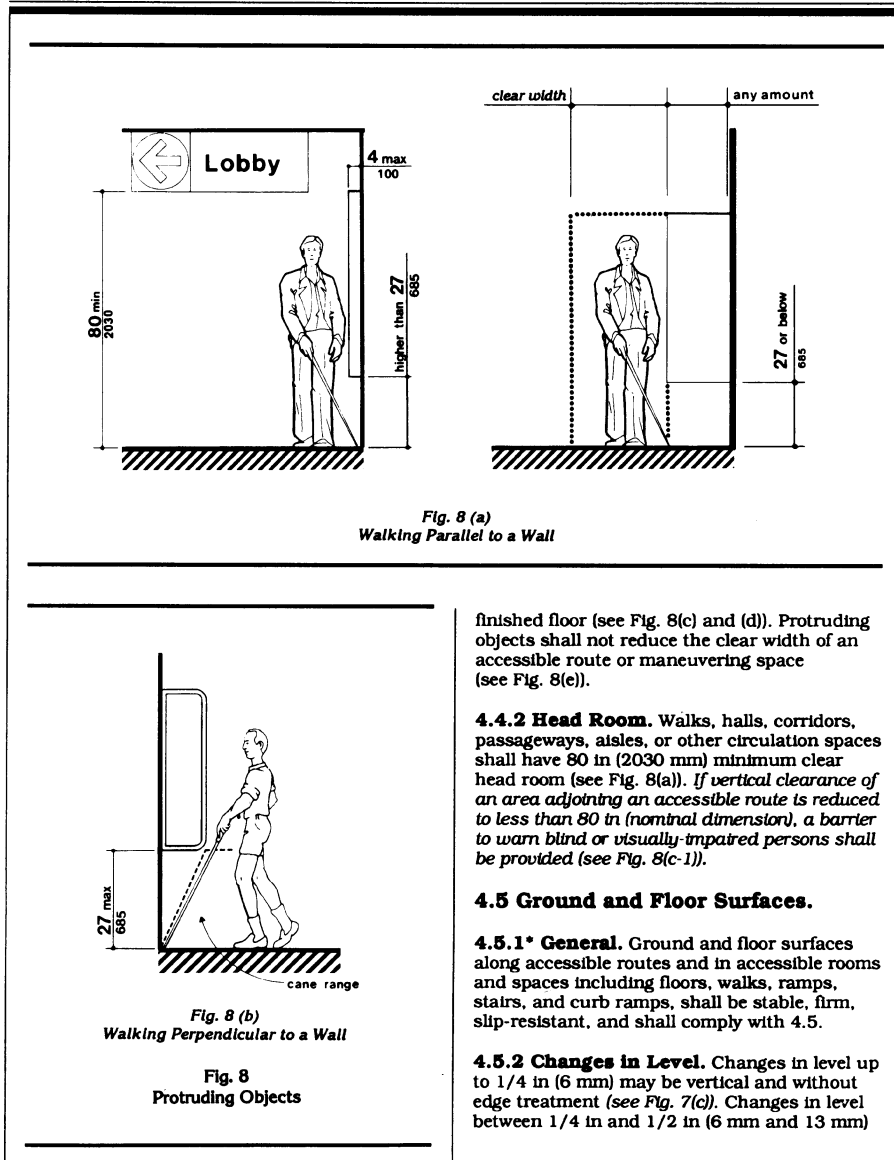

finished floor (see Fig. 8(c) and (d)). Protruding objects shall not reduce the clear width of an accessible route or maneuvering space (see Fig. 8(e)).

**4.4.2 Head Room.** Walks, halls, corridors, passageways, aisles, or other circulation spaces shall have 80 in (2030 mm) minimum clear head room (see Fig. 8(a)). If vertical clearance of an area adjoining an accessible route is reduced to less than 80 in (nominal dimension), a barrier to warn blind or visually-impaired persons shall be provided (see Fig. 8(c-1)).

**4.5 Ground and Floor Surfaces.**

**4.5.1\* General.** Ground and floor surfaces along accessible routes and in accessible rooms and spaces including floors, walks, ramps, stairs, and curb ramps, shall be stable, firm, slip-resistant, and shall comply with 4.5.

**4.5.2 Changes in Level.** Changes in level up to 1/4 in (6 mm) may be vertical and without edge treatment (see Fig. 7(c)). Changes in level between 1/4 in and 1/2 in (6 mm and 13 mm)

4.4 Protruding Objects

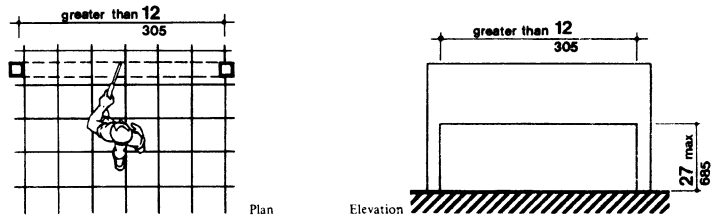

Fig. 8 (c) Free-Standing Overhanging Objects

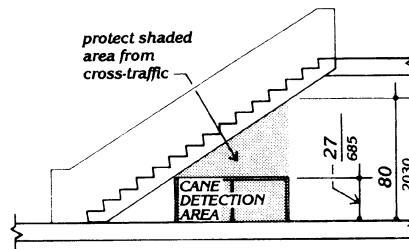

Fig. 8 (c-1) Overhead Hazards

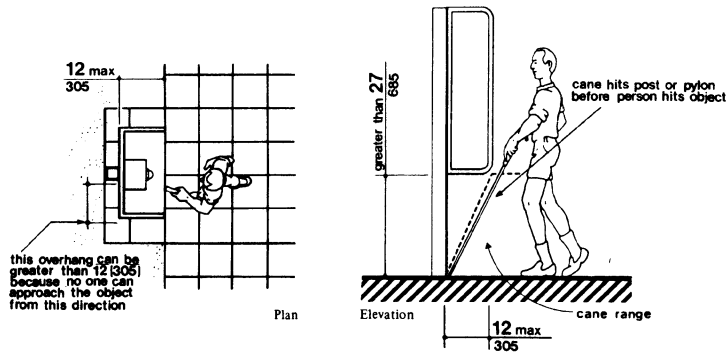
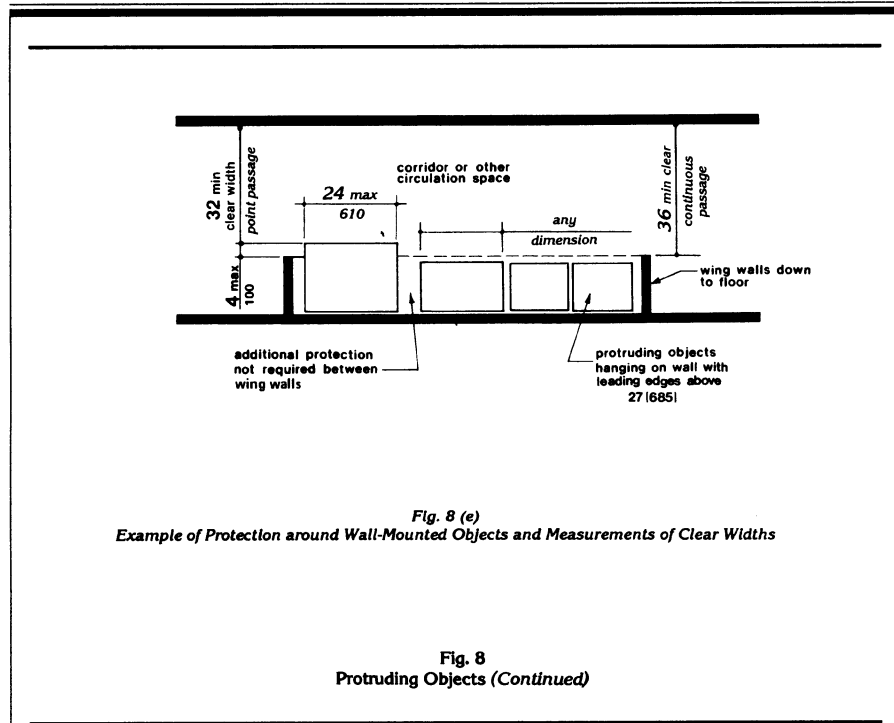

Fig. 8 (d)  
Objects Mounted on Posts or Pylons

Fig. 8  
Protruding Objects (Continued)

**4.5 Ground and Floor Surfaces**



**Fig. 8**  
Protruding Objects (Continued)

shall be beveled with a slope no greater than 1:2 (see Fig. 7(d)). Changes in level greater than 1/2 in (13 mm) shall be accomplished by means of a ramp that complies with 4.7 or 4.8.

**4.5.3\* Carpet.** If carpet or carpet tile is used on a ground or floor surface, then it shall be securely attached; have a firm cushion, pad, or backing, or no cushion or pad; and have a level loop, textured loop, level cut pile, or level cut/uncut pile texture. The maximum pile thickness shall be 1/2 in (13 mm) (see Fig. 8(f)). Exposed edges of carpet shall be fastened to floor surfaces and have trim along the entire length of the exposed edge. Carpet edge trim shall comply with 4.5.2.

**4.5.4 Gratings.** If gratings are located in walking surfaces, then they shall have spaces no greater than 1/2 in (13 mm) wide in one direction (see Fig. 8(g)). If gratings have elongated openings, then they shall be placed so that the long dimension is perpendicular to the dominant direction of travel (see Fig. 8(h)).

**4.6 Parking and Passenger Loading Zones.**

**4.6.1 Minimum Number.** Parking spaces required to be accessible by 4.1 shall comply with 4.6.2 through 4.6.5. Passenger loading zones required to be accessible by 4.1 shall comply with 4.6.5 and 4.6.6.

**4.6 Parking and Passenger Loading Zones**

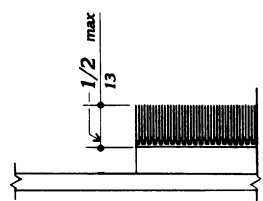

**Fig. 8 (f)**  
Carpet Pile Thickness

---

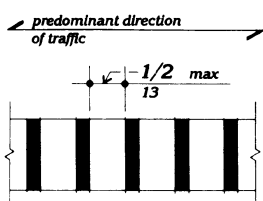

**Fig. 8 (g)**  
Gratings

---

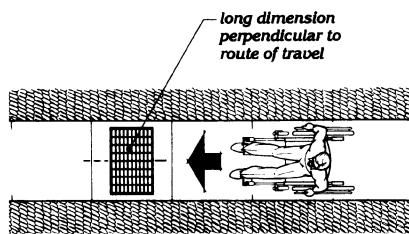

**Fig. 8 (h)**  
Grating Orientation

**4.6.2 Location.** Accessible parking spaces serving a particular building shall be located on the shortest accessible route of travel from adjacent parking to an accessible entrance. In parking facilities that do not serve a particular building, accessible parking shall be located on the shortest accessible route of travel to an accessible pedestrian entrance of the parking facility. In buildings with multiple accessible entrances with adjacent parking, accessible parking spaces shall be dispersed and located closest to the accessible entrances.

**4.6.3\* Parking Spaces.** Accessible parking spaces shall be at least 96 in (2440 mm) wide. Parking access aisles shall be part of an accessible route to the building or facility entrance and shall comply with 4.3. Two accessible parking spaces may share a common access aisle (see Fig. 9). Parked vehicle overhangs shall not reduce the clear width of an accessible route. Parking spaces and access aisles shall be level with surface slopes not exceeding 1:50 (2%) in all directions.

**4.6.4\* Signage.** Accessible parking spaces shall be designated as reserved by a sign showing the symbol of accessibility (see 4.30.7). Spaces complying with 4.1.2(5)(b) shall have an additional sign "Van-Accessible" mounted below the symbol of accessibility. Such signs shall be located so they cannot be obscured by a vehicle parked in the space.

**4.6.5\* Vertical Clearance.** Provide minimum vertical clearance of 114 in (2895 mm) at accessible passenger loading zones and along at least one vehicle access route to such areas from site entrance(s) and exit(s). At parking spaces complying with 4.1.2(5)(b), provide minimum vertical clearance of 98 in (2490 mm) at the parking space and along at least one vehicle access route to such spaces from site entrance(s) and exit(s).

**4.6.6 Passenger Loading Zones.** Passenger loading zones shall provide an access aisle at least 60 in (1525 mm) wide and 20 ft (240 in) (6100 mm) long adjacent and parallel to the vehicle pull-up space (see Fig. 10). If there are curbs between the access aisle and the vehicle pull-up space, then a curb ramp complying with 4.7 shall be provided. Vehicle standing spaces and access aisles shall be level with

**4.7 Curb Ramps**

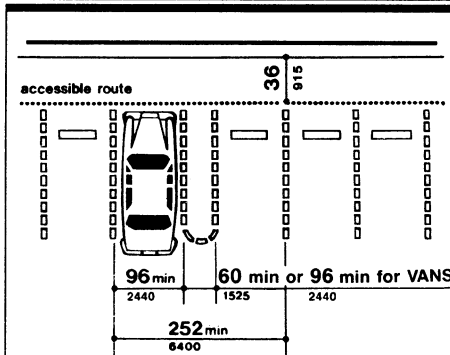

**Fig. 9**  
Dimensions of Parking Spaces

surface slopes not exceeding 1:50 (2%) in all directions.

**4.7 Curb Ramps.**

**4.7.1 Location.** Curb ramps complying with 4.7 shall be provided wherever an accessible route crosses a curb.

**4.7.2 Slope.** Slopes of curb ramps shall comply with 4.8.2. The slope shall be measured as shown in Fig. 11. *Transitions from ramps to walks, gutters, or streets shall be flush and free of abrupt changes. Maximum slopes of adjoining gutters, road surface immediately adjacent to the curb ramp, or accessible route shall not exceed 1:20.*

**4.7.3 Width.** The minimum width of a curb ramp shall be 36 in (915 mm), exclusive of flared sides.

**4.7.4 Surface.** Surfaces of curb ramps shall comply with 4.5.

**4.7.5 Sides of Curb Ramps.** If a curb ramp is located where pedestrians must walk across the ramp, or where it is not protected by handrails or guardrails, it shall have flared sides; the maximum slope of the flare shall be 1:10 (see Fig. 12(a)). Curb ramps with returned curbs

may be used where pedestrians would not normally walk across the ramp (see Fig. 12(b)).

**4.7.6 Built-up Curb Ramps.** Built-up curb ramps shall be located so that they do not project into vehicular traffic lanes (see Fig. 13).

**4.7.7 Detectable Warnings.** A curb ramp shall have a detectable warning complying with 4.29.2. The detectable warning shall extend the full width and depth of the curb ramp.

**4.7.8 Obstructions.** Curb ramps shall be located or protected to prevent their obstruction by parked vehicles.

**4.7.9 Location at Marked Crossings.** Curb ramps at marked crossings shall be wholly contained within the markings, excluding any flared sides (see Fig. 15).

**4.7.10 Diagonal Curb Ramps.** If diagonal (or corner type) curb ramps have returned curbs or other well-defined edges, such edges shall be parallel to the direction of pedestrian flow. The bottom of diagonal curb ramps shall have 48 in (1220 mm) minimum clear space as shown in Fig. 15(c) and (d). If diagonal curb ramps are provided at marked crossings, the 48 in (1220 mm) clear space shall be within the markings (see Fig. 15(c) and (d)). If diagonal curb ramps have flared sides, they shall also have at least a 24 in (610 mm) long segment of straight curb located on each side of the curb ramp and within the marked crossing (see Fig. 15(c)).

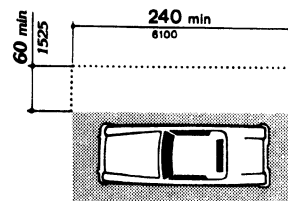

**Fig. 10**  
Access Aisle at Passenger Loading Zones

4.8 Ramps

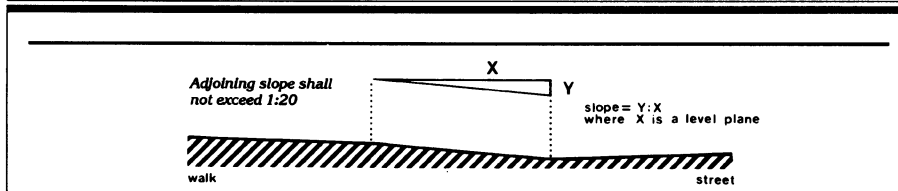
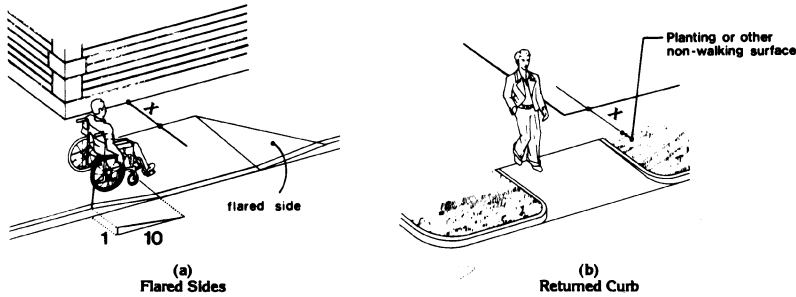

Fig. 11  
Measurement of Curb Ramp Slopes



If X is less than 48 in,  
then the slope of the flared side  
shall not exceed 1:12.

Fig. 12  
Sides of Curb Ramps

**4.7.11 Islands.** Any raised islands in crossings shall be cut through level with the street or have curb ramps at both sides and a level area at least 48 in (1220 mm) long between the curb ramps in the part of the island intersected by the crossings (see Fig. 15(a) and (b)).

**4.8 Ramps.**

**4.8.1\* General.** Any part of an accessible route with a slope greater than 1:20 shall be considered a ramp and shall comply with 4.8.

**4.8.2\* Slope and Rise.** The least possible slope shall be used for any ramp. The maximum slope of a ramp in new construction shall be 1:12. The maximum rise for any run shall be 30 in (760 mm) (see Fig. 16). Curb ramps

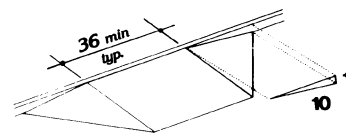

Fig. 13  
Built-Up Curb Ramp

and ramps to be constructed on existing sites or in existing buildings or facilities may have slopes and rises as allowed in 4.1.6(3)(a) if space limitations prohibit the use of a 1:12 slope or less.

4.8 Ramps

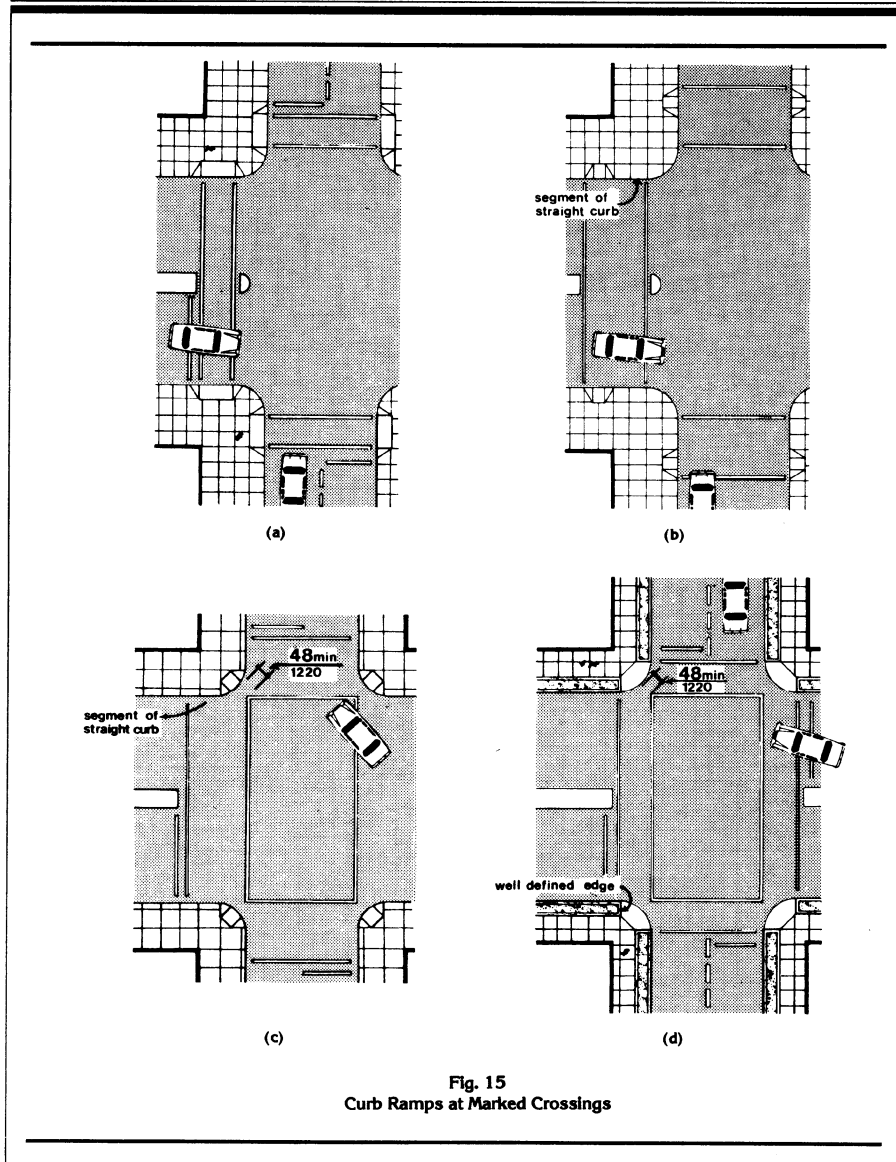

Fig. 15  
Curb Ramps at Marked Crossings

4.8 Ramps

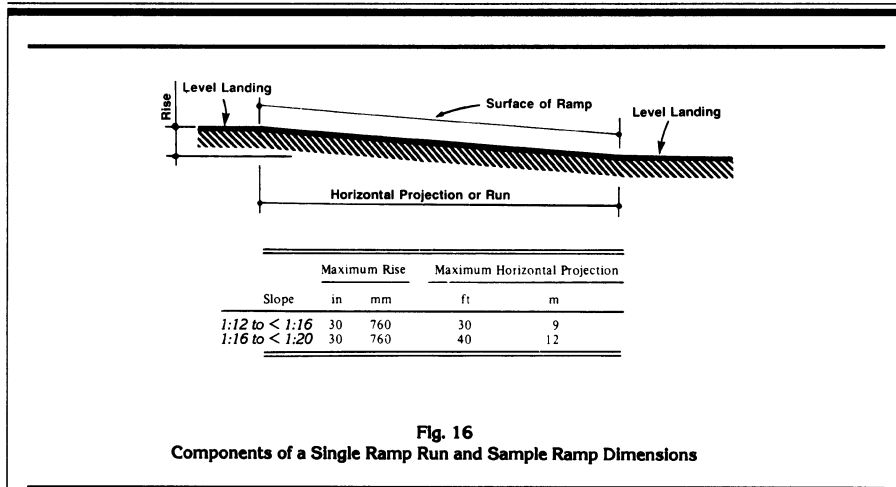

Fig. 16  
Components of a Single Ramp Run and Sample Ramp Dimensions

**4.8.3 Clear Width.** The minimum clear width of a ramp shall be 36 in (915 mm).

**4.8.4\* Landings.** Ramps shall have level landings at bottom and top of each ramp and each ramp run. Landings shall have the following features:

- (1) The landing shall be at least as wide as the ramp run leading to it.
- (2) The landing length shall be a minimum of 60 in (1525 mm) clear.
- (3) If ramps change direction at landings, the minimum landing size shall be 60 in by 60 in (1525 mm by 1525 mm).
- (4) If a doorway is located at a landing, then the area in front of the doorway shall comply with 4.13.6.

**4.8.5\* Handrails.** If a ramp run has a rise greater than 6 in (150 mm) or a horizontal projection greater than 72 in (1830 mm), then it shall have handrails on both sides. Handrails are not required on curb ramps or adjacent to seating in assembly areas. Handrails shall comply with 4.26 and shall have the following features:

(1) Handrails shall be provided along both sides of ramp segments. The inside handrail on switchback or dogleg ramps shall always be continuous.

(2) If handrails are not continuous, they shall extend at least 12 in (305 mm) beyond the top and bottom of the ramp segment and shall be parallel with the floor or ground surface (see Fig. 17).

(3) The clear space between the handrail and the wall shall be 1 - 1/2 in (38 mm).

(4) Gripping surfaces shall be continuous.

(5) Top of handrail gripping surfaces shall be mounted between 34 in and 38 in (865 mm and 965 mm) above ramp surfaces.

(6) Ends of handrails shall be either rounded or returned smoothly to floor, wall, or post.

(7) Handrails shall not rotate within their fittings.

**4.8.6 Cross Slope and Surfaces.** The cross slope of ramp surfaces shall be no greater than 1:50. Ramp surfaces shall comply with 4.5.



**4.9 Stairs**

**4.8.7 Edge Protection.** Ramps and landings with drop-offs shall have curbs, walls, railings, or projecting surfaces that prevent people from slipping off the ramp. Curbs shall be a minimum of 2 in (50 mm) high (see Fig. 17).

**4.8.8 Outdoor Conditions.** Outdoor ramps and their approaches shall be designed so that water will not accumulate on walking surfaces.

**4.9 Stairs.**

**4.9.1\* Minimum Number.** *Stairs required to be accessible by 4.1 shall comply with 4.9.*

**4.9.2 Treads and Risers.** On any given flight of stairs, all steps shall have uniform riser heights and uniform tread widths. Stair treads shall be no less than 11 in (280 mm) wide, measured from riser to riser (see Fig. 18(a)). *Open risers are not permitted.*

**4.9.3 Nosings.** The undersides of nosings shall not be abrupt. The radius of curvature at the leading edge of the tread shall be no greater than 1/2 in (13 mm). Risers shall be sloped or the underside of the nosing shall have an angle not less than 60 degrees from the horizontal. Nosings shall project no more than 1-1/2 in (38 mm) (see Fig. 18).

**4.9.4 Handrails.** Stairways shall have handrails at both sides of all stairs. Handrails shall comply with 4.26 and shall have the following features:

(1) Handrails shall be continuous along both sides of stairs. The inside handrail on switchback or dogleg stairs shall always be continuous (see Fig. 19(a) and (b)).

(2) If handrails are not continuous, they shall extend at least 12 in (305 mm) beyond the top riser and at least 12 in (305 mm) plus the width of one tread beyond the bottom riser. At the top, the extension shall be parallel with the floor or ground surface. At the bottom, the handrail shall continue to slope for a distance of the width of one tread from the bottom riser; the remainder of the extension shall be horizontal (see Fig. 19(c) and (d)). Handrail extensions shall comply with 4.4.

(3) The clear space between handrails and wall shall be 1-1/2 in (38 mm).

(4) Gripping surfaces shall be uninterrupted by newel posts, other construction elements, or obstructions.

(5) *Top of handrail gripping surface shall be mounted between 34 in and 38 in (865 mm and 965 mm) above stair nosings.*

(6) *Ends of handrails shall be either rounded or returned smoothly to floor, wall or post.*

(7) *Handrails shall not rotate within their fittings.*

**4.9.5 Detectable Warnings at Stairs.** *(Reserved).*

**4.9.6 Outdoor Conditions.** Outdoor stairs and their approaches shall be designed so that water will not accumulate on walking surfaces.

**4.10 Elevators.**

**4.10.1 General.** *Accessible* elevators shall be on an accessible route and shall comply with 4.10 and with the ASME A17.1-1990, Safety Code for Elevators and Escalators. *Freight elevators shall not be considered as meeting the requirements of this section unless the only elevators provided are used as combination passenger and freight elevators for the public and employees.*

**4.10.2 Automatic Operation.** Elevator operation shall be automatic. Each car shall be equipped with a self-leveling feature that will automatically bring the car to floor landings within a tolerance of 1/2 in (13 mm) under rated loading to zero loading conditions. This self-leveling feature shall be automatic and independent of the operating device and shall correct the overtravel or undertravel.

**4.10.3 Hall Call Buttons.** Call buttons in elevator lobbies and halls shall be centered at 42 in (1065 mm) above the floor. Such call buttons shall have visual signals to indicate when each call is registered and when each call is answered. Call buttons shall be a minimum of 3/4 in (19 mm) in the smallest dimension. The button designating the up direction shall be on top. (See Fig. 20.) *Buttons shall be raised or flush. Objects mounted beneath hall call buttons shall not project into the elevator lobby more than 4 in (100 mm).*

4.10 Elevators

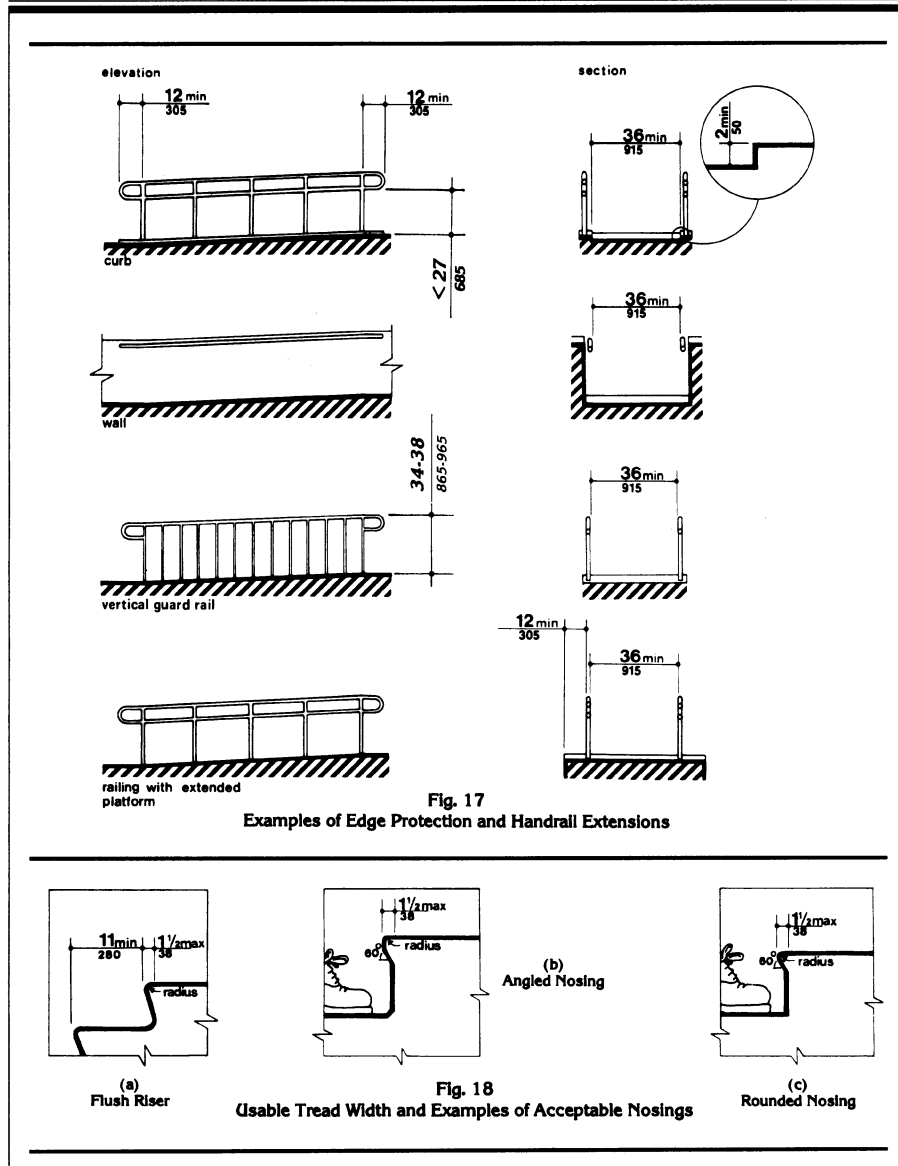

4.10 Elevators

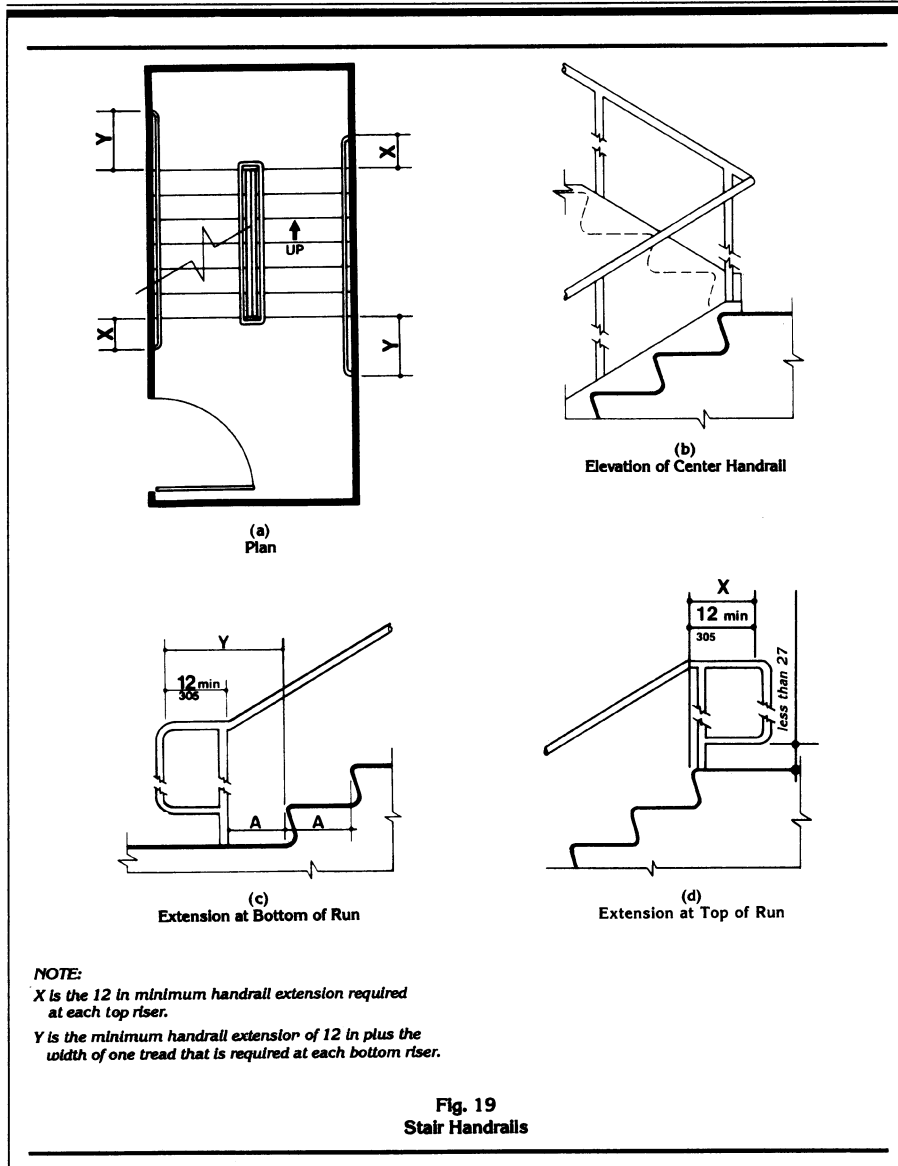

## 4.10 Elevators

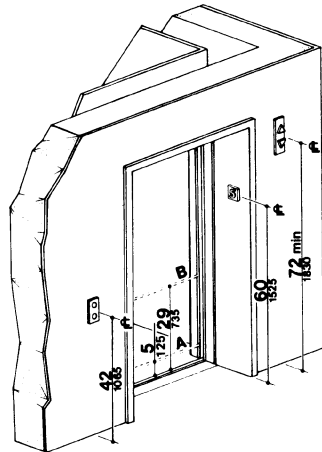

NOTE: The automatic door reopening device is activated if an object passes through either line A or line B. Line A and line B represent the vertical locations of the door reopening device not requiring contact.

Fig. 20  
Hoistway and Elevator Entrances

**4.10.4 Hall Lanterns.** A visible and audible signal shall be provided at each hoistway entrance to indicate which car is answering a call. Audible signals shall sound once for the up direction and twice for the down direction or shall have verbal annunciators that say "up" or "down." Visible signals shall have the following features:

- (1) Hall lantern fixtures shall be mounted so that their centerline is at least 72 in (1830 mm) above the lobby floor. (See Fig. 20.)
- (2) Visual elements shall be at least 2-1/2 in (64 mm) in the smallest dimension.
- (3) Signals shall be visible from the vicinity of the hall call button (see Fig. 20). In-car lanterns located in cars, visible from the vicinity of hall call buttons, and conforming to the above requirements, shall be acceptable.

**4.10.5 Raised and Braille Characters on Hoistway Entrances.** All elevator hoistway entrances shall have *raised and Braille* floor designations provided on both jambs. The centerline of the characters shall be 60 in (1525 mm) above *finish* floor. Such characters shall be 2 in (50 mm) high and shall comply with 4.30.4. Permanently applied plates are acceptable if they are permanently fixed to the jambs. (See Fig. 20).

**4.10.6\* Door Protective and Reopening Device.** Elevator doors shall open and close automatically. They shall be provided with a reopening device that will stop and reopen a car door and hoistway door automatically if the door becomes obstructed by an object or person. The device shall be capable of completing these operations without requiring contact for an obstruction passing through the opening at heights of 5 in and 29 in (125 mm and 735 mm) above *finish* floor (see Fig. 20). Door reopening devices shall remain effective for at least 20 seconds. After such an interval, doors may close in accordance with the requirements of ASME A17.1-1990.

**4.10.7\* Door and Signal Timing for Hall Calls.** The minimum acceptable time from notification that a car is answering a call until the doors of that car start to close shall be calculated from the following equation:

$$T = D/(1.5 \text{ ft/s}) \text{ or } T = D/(445 \text{ mm/s})$$

where T total time in seconds and D distance (in feet or millimeters) from a point in the lobby or corridor 60 in (1525 mm) directly in front of the farthest call button controlling that car to the centerline of its hoistway door (see Fig. 21). For cars with in-car lanterns, T begins when the lantern is visible from the vicinity of hall call buttons and an audible signal is sounded. *The minimum acceptable notification time shall be 5 seconds.*

**4.10.8 Door Delay for Car Calls.** The minimum time for elevator doors to remain fully open in response to a car call shall be 3 seconds.

**4.10.9 Floor Plan of Elevator Cars.** The floor area of elevator cars shall provide space for wheelchair users to enter the car, maneuver

**4.10.12 Car Controls**

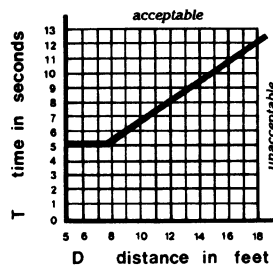

**Fig. 21**  
Graph of Timing Equation

within reach of controls, and exit from the car. Acceptable door opening and inside dimensions shall be as shown in Fig. 22. The clearance between the car platform sill and the edge of any hoistway landing shall be no greater than 1-1/4 in (32 mm).

**4.10.10 Floor Surfaces.** Floor surfaces shall comply with 4.5.

**4.10.11 Illumination Levels.** The level of illumination at the car controls, platform, and car threshold and landing sill shall be at least 5 footcandles (53.8 lux).

**4.10.12\* Car Controls.** Elevator control panels shall have the following features:

(1) Buttons. All control buttons shall be at least 3/4 in (19 mm) in their smallest dimension. They shall be raised or flush.

(2) Tactile, Braille, and Visual Control Indicators. All control buttons shall be designated by Braille and by raised standard alphabet characters for letters, arabic characters for numerals, or standard symbols as shown in Fig. 23(a), and as required in ASME A17.1-1990. Raised and Braille characters and symbols shall comply with 4.30. The call button for the main entry floor shall be designated by a raised star at the left of the floor designation (see Fig. 23(a)). All raised designations for control buttons shall be placed immediately to the left of the button to which they apply. Applied plates,

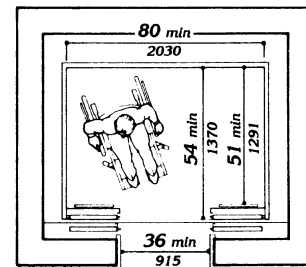

(a)

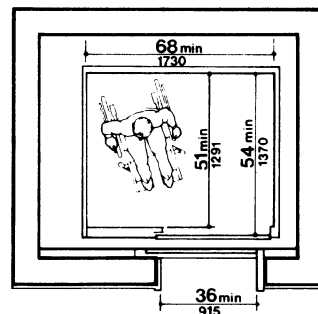

(b)

**Fig. 22**  
Minimum Dimensions of Elevator Cars

permanently attached, are an acceptable means to provide raised control designations. Floor buttons shall be provided with visual indicators to show when each call is registered. The visual indicators shall be extinguished when each call is answered.

(3) Height. All floor buttons shall be no higher than 54 in (1370 mm) above the finish floor for side approach and 48 in (1220 mm) for front approach. Emergency controls, including the emergency alarm and emergency stop, shall be grouped at the bottom of the panel and shall have their centerlines no less than 35 in (890 mm) above the finish floor (see Fig. 23(a) and (b)).

4.10.13\* Car Position Indicators

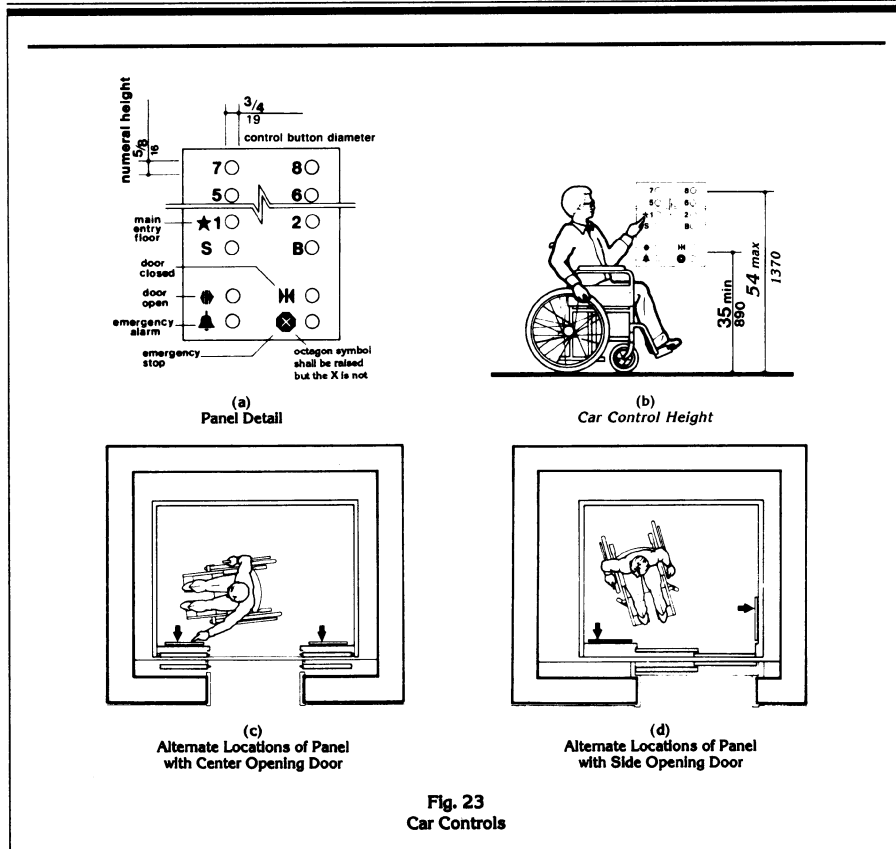

(4) Location. Controls shall be located on a front wall if cars have center opening doors, and at the side wall or at the front wall next to the door if cars have side opening doors (see Fig. 23(c) and (d)).

**4.10.13\* Car Position Indicators.** In elevator cars, a visual car position indicator shall be provided above the car control panel or over the door to show the position of the elevator in the hoistway. As the car passes or stops at a floor served by the elevators, the corresponding numerals shall illuminate,

and an audible signal shall sound. Numerals shall be a minimum of 1/2 in (13 mm) high. The audible signal shall be no less than 20 decibels with a frequency no higher than 1500 Hz. An automatic verbal announcement of the floor number at which a car stops or which a car passes may be substituted for the audible signal.

**4.10.14\* Emergency Communications.** If provided, emergency two-way communication systems between the elevator and a point outside the hoistway shall comply with ASME

**4.11 Platform Lifts (Wheelchair Lifts)**

A17.1-1990. The highest operable part of a two-way communication system shall be a maximum of 48 in (1220 mm) from the floor of the car. It shall be identified by a raised symbol and lettering complying with 4.30 and located adjacent to the device. If the system uses a handset then the length of the cord from the panel to the handset shall be at least 29 in (735 mm). *If the system is located in a closed compartment the compartment door hardware shall conform to 4.27, Controls and Operating Mechanisms. The emergency inter-communication system shall not require voice communication.*

**4.11 Platform Lifts (Wheelchair Lifts).**

**4.11.1 Location.** Platform lifts (wheelchair lifts) permitted by 4.1 shall comply with the requirements of 4.11.

**4.11.2\* Other Requirements.** If platform lifts (wheelchair lifts) are used, they shall comply with 4.2.4, 4.5, 4.27, and ASME A17.1 Safety Code for Elevators and Escalators, Section XX, 1990.

**4.11.3 Entrance.** If platform lifts are used then they shall facilitate unassisted entry, operation, and exit from the lift in compliance with 4.11.2.

**4.12 Windows.**

**4.12.1\* General.** (Reserved).

**4.12.2\* Window Hardware.** (Reserved).

**4.13 Doors.**

**4.13.1 General.** Doors required to be accessible by 4.1 shall comply with the requirements of 4.13.

**4.13.2 Revolving Doors and Turnstiles.** Revolving doors or turnstiles shall not be the only means of passage at an accessible entrance or along an accessible route. An accessible gate or door shall be provided adjacent to the turnstile or revolving door and shall be so designed as to facilitate the same use pattern.

**4.13.3 Gates.** Gates, including ticket gates, shall meet all applicable specifications of 4.13.

**4.13.4 Double-Leaf Doorways.** If doorways have two *independently operated* door leaves, then at least one leaf shall meet the specifications in 4.13.5 and 4.13.6. That leaf shall be an active leaf.

**4.13.5 Clear Width.** Doorways shall have a minimum clear opening of 32 in (815 mm) with the door open 90 degrees, measured between the face of the door and the *opposite* stop (see Fig. 24(a), (b), (c), and (d)). Openings more than 24 in (610 mm) in depth shall comply with 4.2.1 and 4.3.3 (see Fig. 24(e)).

*EXCEPTION: Doors not requiring full user passage, such as shallow closets, may have the clear opening reduced to 20 in (510 mm) minimum.*

**4.13.6 Maneuvering Clearances at Doors.** Minimum maneuvering clearances at doors that are not automatic or power-assisted shall be as shown in Fig. 25. The floor or ground area within the required clearances shall be level and clear.

*EXCEPTION: Entry doors to acute care hospital bedrooms for in-patients shall be exempted from the requirement for space at the latch side of the door (see dimension "x" in Fig. 25) if the door is at least 44 in (1120 mm) wide.*

**4.13.7 Two Doors in Series.** The minimum space between two hinged or pivoted doors in series shall be 48 in (1220 mm) plus the width of any door swinging into the space. Doors in series shall swing either in the same direction or away from the space between the doors (see Fig. 26).

**4.13.8\* Thresholds at Doorways.** Thresholds at doorways shall not exceed 3/4 in (19 mm) in height for exterior sliding doors or 1/2 in (13 mm) for other types of doors. Raised thresholds and floor level changes at accessible doorways shall be beveled with a slope no greater than 1:2 (see 4.5.2).

**4.13.9\* Door Hardware.** Handles, pulls, latches, locks, and other operating devices on accessible doors shall have a shape that is easy

4.13 Doors

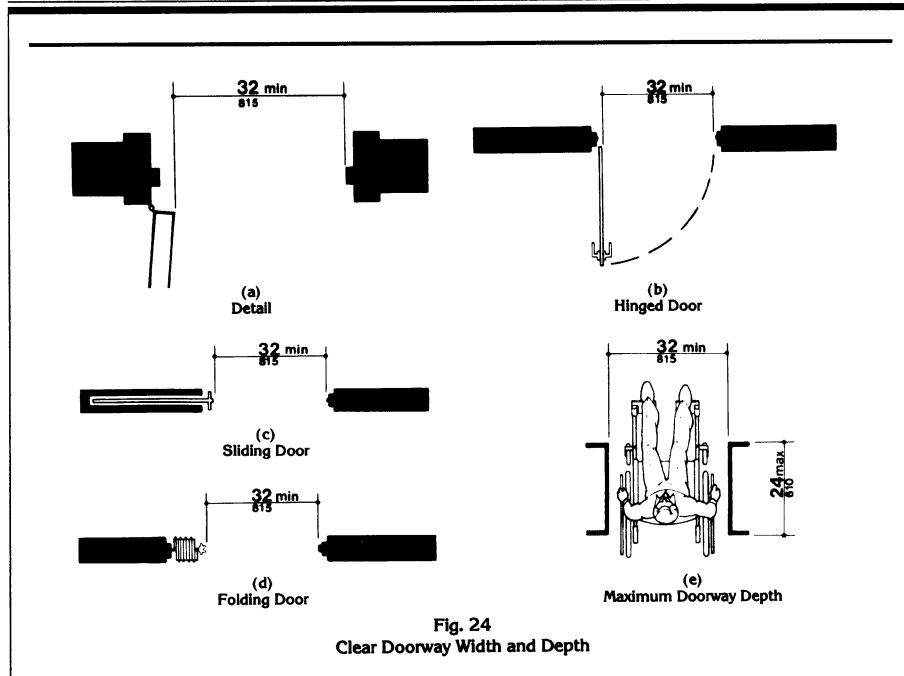

to grasp with one hand and does not require tight grasping, tight pinching, or twisting of the wrist to operate. Lever-operated mechanisms, push-type mechanisms, and U-shaped handles are acceptable designs. When sliding doors are fully open, operating hardware shall be exposed and usable from both sides. *Hardware required for accessible door passage shall be mounted no higher than 48 in (1220 mm) above finished floor.*

**4.13.10\* Door Closers.** If a door has a closer, then the sweep period of the closer shall be adjusted so that from an open position of 70 degrees, the door will take at least 3 seconds to move to a point 3 in (75 mm) from the latch, measured to the leading edge of the door.

**4.13.11\* Door Opening Force.** The maximum force for pushing or pulling open a door shall be as follows:

- (1) Fire doors shall have the minimum opening force allowable by the appropriate administrative authority.
- (2) Other doors.
  - (a) exterior hinged doors: *(Reserved)*.
  - (b) interior hinged doors: 5 lbf (22.2N)
  - (c) sliding or folding doors: 5 lbf (22.2N)

These forces do not apply to the force required to retract latch bolts or disengage other devices that may hold the door in a closed position.



4.13 Doors

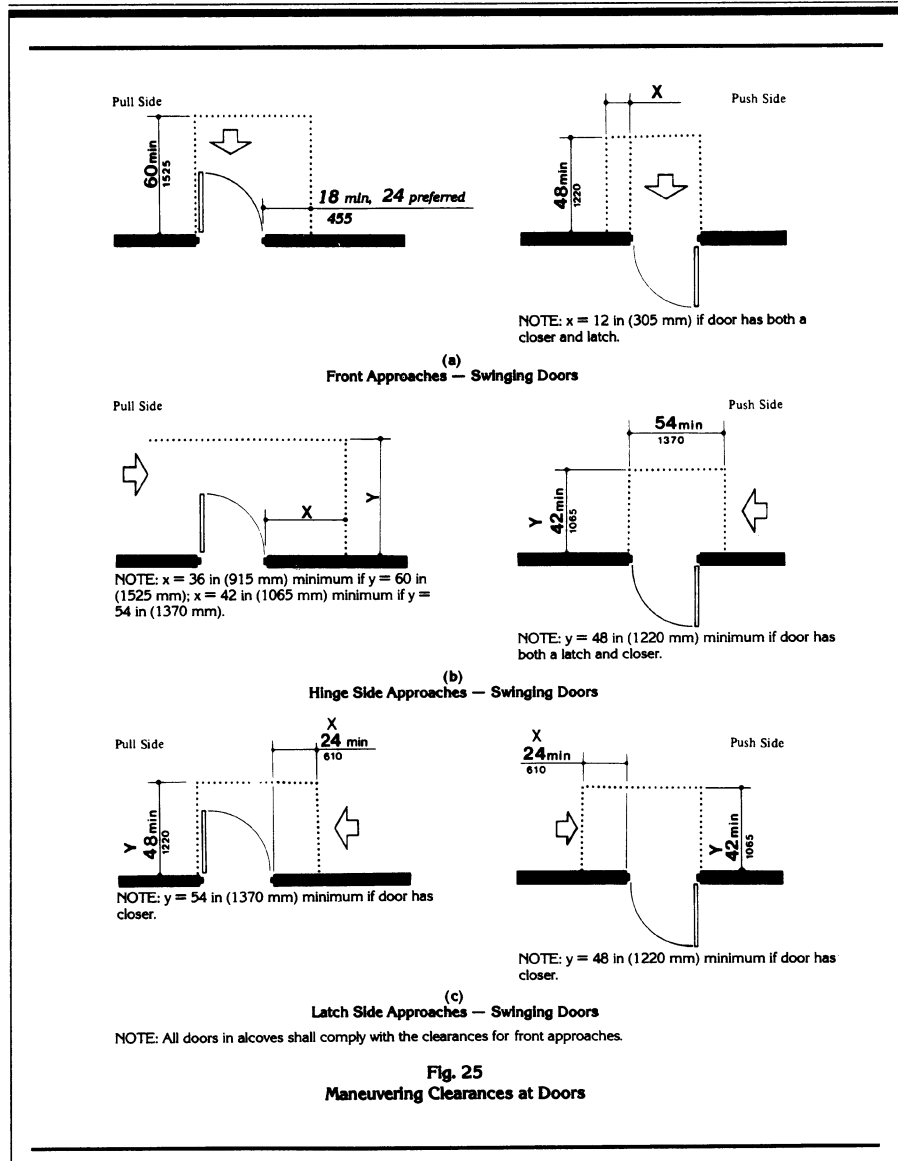

4.13 Doors

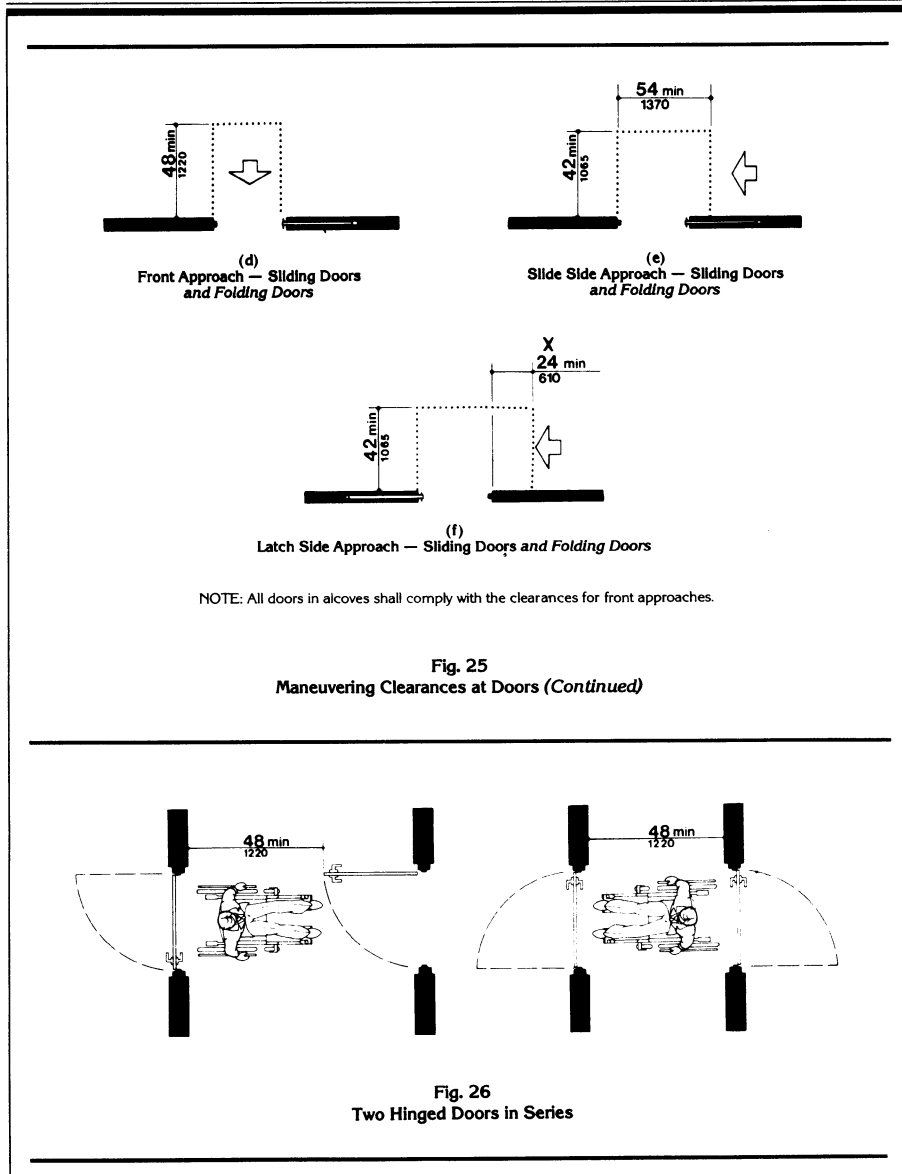

**4.14 Entrances**

<p><b>4.13.12* Automatic Doors and Power-Assisted Doors.</b> If an automatic door is used, then it shall comply with <i>ANSI/BHMA A156.10-1985</i>. Slowly opening, low-powered, automatic doors shall <i>comply with ANSI A156.19-1984</i>. Such doors shall not open to back check faster than 3 seconds and shall require no more than 15 lbf (66.6N) to stop door movement. If a power-assisted door is used, its door-opening force shall comply with 4.13.11 and its closing shall conform to the requirements in <i>ANSI A156.19-1984</i>.</p> <p><b>4.14 Entrances.</b></p> <p><b>4.14.1 Minimum Number.</b> <i>Entrances required to be accessible by 4.1</i> shall be part of an accessible route complying with 4.3. Such entrances shall be connected by an accessible route to public transportation stops, to accessible parking and passenger loading zones, and to public streets or sidewalks if available (see 4.3.2(1)). They shall also be connected by an accessible route to all accessible spaces or elements within the building or facility.</p> <p><b>4.14.2 Service Entrances.</b> A service entrance shall not be the sole accessible entrance unless it is the only entrance to a building or facility (for example, in a factory or garage).</p> <p><b>4.15 Drinking Fountains and Water Coolers.</b></p> <p><b>4.15.1 Minimum Number.</b> <i>Drinking fountains or water coolers required to be accessible by 4.1</i> shall comply with 4.15.</p> <p><b>4.15.2* Spout Height.</b> Spouts shall be no higher than 36 in (915 mm), measured from the floor or ground surfaces to the spout outlet (see Fig. 27(a)).</p> <p><b>4.15.3 Spout Location.</b> The spouts of drinking fountains and water coolers shall be at the front of the unit and shall direct the water flow in a trajectory that is parallel or nearly parallel to the front of the unit. The spout shall provide a flow of water at least 4 in (100 mm) high so as to allow the insertion of a cup or glass under the flow of water. <i>On an accessible drinking fountain with a round or oval bowl, the spout must be positioned so the flow of water is within 3 in (75 mm) of the front edge of the fountain.</i></p>	<p><b>4.15.4 Controls.</b> Controls shall comply with 4.27.4. <i>Unit controls shall be front mounted or side mounted near the front edge.</i></p> <p><b>4.15.5 Clearances.</b></p> <p>(1) Wall- and post-mounted cantilevered units shall have a clear knee space between the bottom of the apron and the floor or ground at least 27 in (685 mm) high, 30 in (760 mm) wide, and 17 in to 19 in (430 mm to 485 mm) deep (see Fig. 27(a) and (b)). Such units shall also have a minimum clear floor space 30 in by 48 in (760 mm by 1220 mm) to allow a person in a wheelchair to approach the unit facing forward.</p> <p><i>EXCEPTION: These clearances shall not be required at units used primarily by children ages 12 and younger where clear floor space for a parallel approach complying with 4.2.4 is provided and where the spout is no higher than 30 in (760 mm), measured from the floor or ground surface to the spout outlet.</i></p> <p>(2) Free-standing or built-in units not having a clear space under them shall have a clear floor space at least 30 in by 48 in (760 mm by 1220 mm) that allows a person in a wheelchair to make a parallel approach to the unit (see Fig. 27(c) and (d)). This clear floor space shall comply with 4.2.4.</p> <p><b>4.16 Water Closets.</b></p> <p><b>4.16.1 General.</b> Accessible water closets shall comply with 4.16.2 through 4.16.6.</p> <p><i>EXCEPTION: Water closets used primarily by children ages 12 and younger shall be permitted to comply with 4.16.7.</i></p> <p><b>4.16.2 Clear Floor Space.</b> Clear floor space for water closets not in stalls shall comply with Fig. 28. Clear floor space may be arranged to allow either a left-handed or right-handed approach.</p> <p><b>4.16.3* Height.</b> The height of water closets shall be 17 in to 19 in (430 mm to 485 mm), measured to the top of the toilet seat (see Fig. 29(b)). <i>Seats shall not be sprung to return to a lifted position.</i></p>
---	---

4.16 Water Closets

**4.16.4\* Grab Bars.** Grab bars for water closets not located in stalls shall comply with 4.26 and Fig. 29. *The grab bar behind the water closet shall be 36 in (915 mm) minimum.*

**4.16.5\* Flush Controls.** Flush controls shall be hand operated or automatic and shall comply with 4.27.4. Controls for flush valves shall be mounted on the wide side of toilet areas no more than 44 in (1120 mm) above the floor.

**4.16.6 Dispensers.** Toilet paper dispensers shall be installed within reach, as shown in Fig. 29(b). *Dispensers that control delivery, or that do not permit continuous paper flow, shall not be used.*

**4.16.7\* Water Closets for Children.** *Water closets used primarily by children ages 12 and younger shall comply with 4.16.7 as permitted by 4.16.1.*

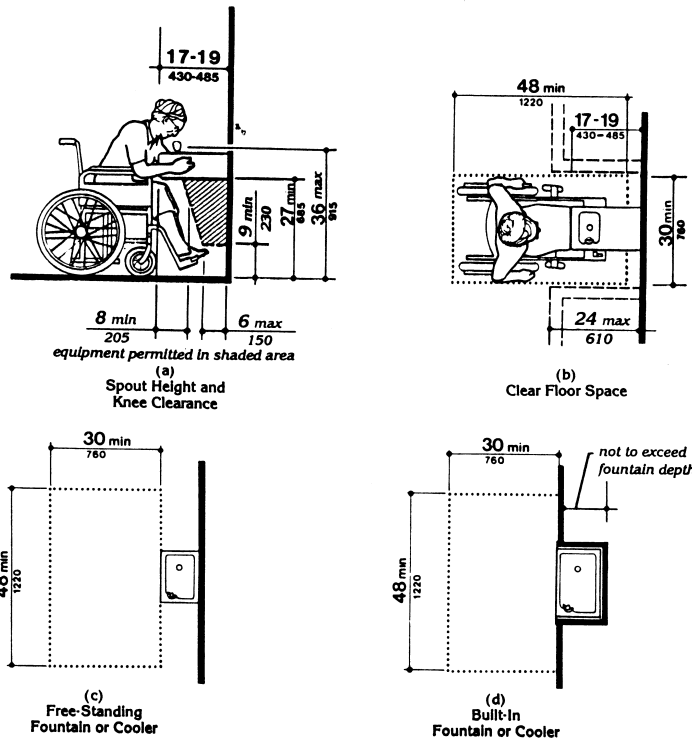

Fig. 27  
Drinking Fountains and Water Coolers

**4.17 Toilet Stalls**

<p>(1) <i>Clear Floor Space.</i> Clear floor space for water closets not in stalls shall comply with Fig. 28 except that the centerline of water closets shall be 12 in minimum to 18 in maximum (305 mm to 455 mm) from the side wall or partition. Clear floor space may be arranged to allow either a left- or right-hand approach.</p> <p>(2) <i>Height.</i> The height of water closets shall be 11 in minimum to 17 in maximum (280 mm to 430 mm), measured to the top of the toilet seat. Seats shall not be sprung to return to a lifted position.</p> <p>(3) <i>Grab Bars.</i> Grab bars for water closets not located in stalls shall comply with 4.26 and Fig. 29 except that grab bars shall be mounted 18 in minimum to 27 in maximum (455 mm to 685 mm) above the finish floor measured to the grab bar centerline. The grab bar behind the water closet shall be 36 in (915 mm) minimum.</p> <p><i>EXCEPTION:</i> If administrative authorities require flush controls for flush valves to be located in a position that conflicts with the location of the rear grab bar, then that grab bar may be split or, at water closets with a centerline placement below 15 in (380 mm), a rear grab bar 24 in (610 mm) minimum on the open side of the toilet area shall be permitted.</p> <p>(4) <i>Flush Controls.</i> Flush controls shall be hand operated or automatic and shall comply with 4.27.4. Controls for flush valves shall be mounted on the wide side of the toilet area no more than 36 in (915 mm) above the floor.</p> <p>(5) <i>Dispensers.</i> Toilet paper dispensers shall be installed 14 in minimum to 19 in maximum (355 mm to 485 mm) above the finish floor measured to the dispenser centerline. Dispensers that control delivery, or that do not permit continuous paper flow, shall not be used.</p> <p><b>4.17 Toilet Stalls.</b></p> <p><b>4.17.1 Location.</b> Accessible toilet stalls shall be on an accessible route and shall meet the requirements of 4.17.2 through 4.17.6.</p> <p><i>EXCEPTION:</i> Toilet stalls used primarily by children ages 12 and younger shall be permitted to comply with 4.17.7.</p> <p><b>4.17.2 Water Closets.</b> Water closets in accessible stalls shall comply with 4.16.</p>	
---	--

41A

4.17 Toilet Stalls

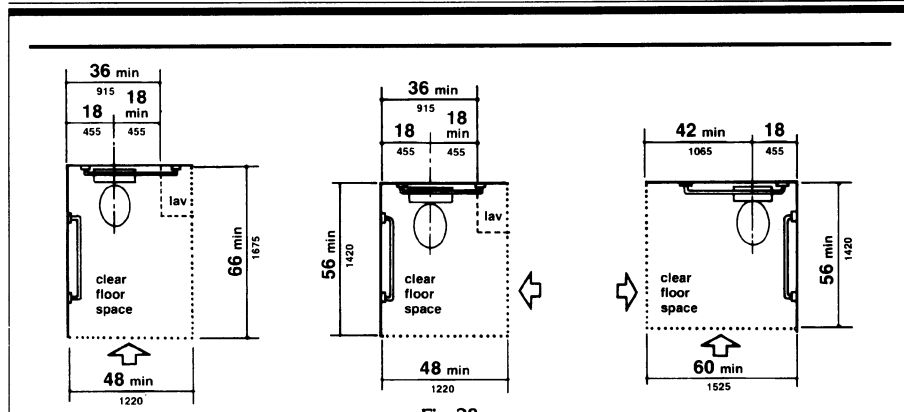

Fig. 28  
Clear Floor Space at Water Closets

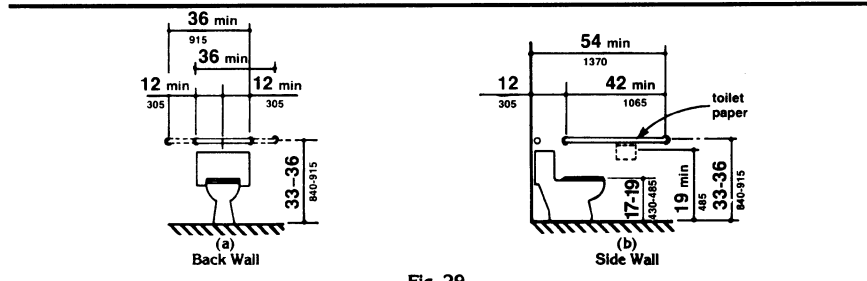

Fig. 29  
Grab Bars at Water Closets

**4.17.3\* Size and Arrangement.** The size and arrangement of the standard toilet stall shall comply with Fig. 30(a), *Standard Stall*. Standard toilet stalls with a minimum depth of 56 in (1420 mm) (see Fig. 30(a)) shall have wall-mounted water closets. If the depth of a standard toilet stall is increased at least 3 in (75 mm), then a floor-mounted water closet may be used. Arrangements shown for standard toilet stalls may be reversed to allow either a left- or right-hand approach. Additional stalls shall be provided in conformance with 4.22.4.

*EXCEPTION: In instances of alteration work where provision of a standard stall (Fig. 30(a))*

*is technically infeasible or where plumbing code requirements prevent combining existing stalls to provide space, either alternate stall (Fig. 30(b)) may be provided in lieu of the standard stall.*

**4.17.4 Toe Clearances.** In standard stalls, the front partition and at least one side partition shall provide a toe clearance of at least 9 in (230 mm) above the floor. If the depth of the stall is greater than 60 in (1525 mm), then the toe clearance is not required.

**4.17.5\* Doors.** Toilet stall doors, including door hardware, shall comply with 4.13. If toilet stall approach is from the latch side of the stall door, clearance between the door side of the

4.17 Toilet Stalls

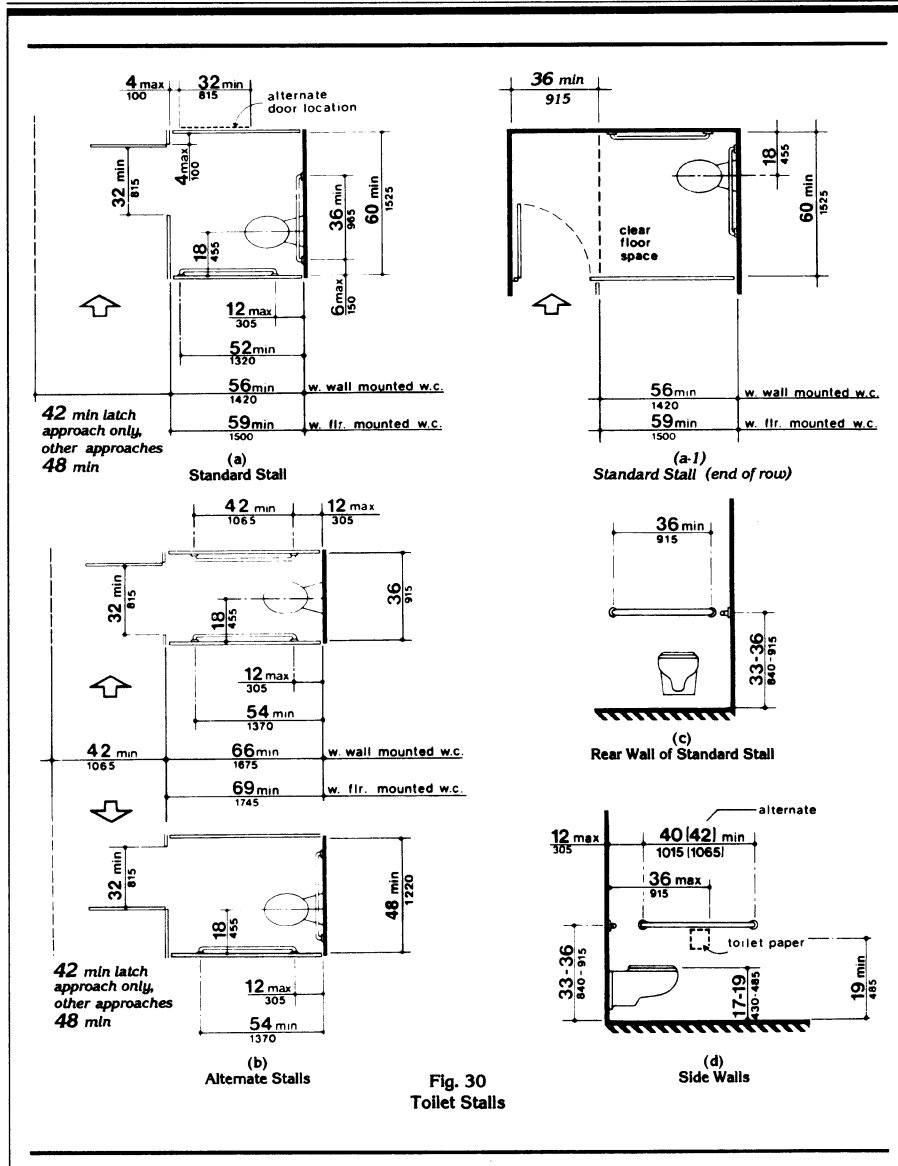

Fig. 30 Toilet Stalls

**4.17 Toilet Stalls**

stall and any obstruction may be reduced to a minimum of 42 in (1065 mm) (Fig. 30).

**4.17.6 Grab Bars.** Grab bars complying with the length and positioning shown in Fig. 30(a), (b), (c), and (d) shall be provided. Grab bars may be mounted with any desired method as long as they have a gripping surface at the locations shown and do not obstruct the required clear floor area. Grab bars shall comply with 4.26.

**4.17.7\* Toilet Stalls for Children.** Toilet stalls used primarily by children ages 12 and younger shall comply with 4.17.7 as permitted by 4.17.1.

(1) *Water Closets.* Water closets in accessible stalls shall comply with 4.16.7.

(2) *Size and Arrangement.* The size and arrangement of the standard toilet stall shall comply with 4.17.3 and Fig. 30(a), Standard Stall, except that the centerline of water closets shall be 12 in minimum to 18 in maximum (305 mm to 455 mm) from the side wall or partition and the minimum depth for stalls with wall-mounted water closets shall be 59 in (1500 mm). Alternate stalls complying with Fig. 30(b) may be provided where permitted by 4.17.3 except that the stall shall have a minimum depth of 69 in (1745 mm) where wall-mounted water closets are provided.

(3) *Toe Clearances.* In standard stalls, the front partition and at least one side partition shall provide a toe clearance of at least 12 in (305 mm) above the finish floor.

(4) *Doors.* Toilet stall doors shall comply with 4.17.5.

(5) *Grab Bars.* Grab bars shall comply with 4.17.6 and the length and positioning shown in Fig. 30(a), (b), (c), and (d) except that grab bars shall be mounted 18 in minimum to 27 in maximum (455 mm to 685 mm) above the finish floor measured to the grab bar centerline.

**EXCEPTION:** If administrative authorities require flush controls for flush valves to be located in a position that conflicts with the location of the rear grab bar, then that grab bar may be split or, at water closets with a

centerline placement below 15 in (380 mm), a rear grab bar 24 in (610 mm) minimum on the open side of the toilet area shall be permitted.

**4.18 Urinals.**

**4.18.1 General.** Accessible urinals shall comply with 4.18.

**4.18.2 Height.** Urinals shall be stall-type or wall-hung with an elongated rim at a maximum of 17 in (430 mm) above the finish floor.

**4.18.3 Clear Floor Space.** A clear floor space 30 in by 48 in (760 mm by 1220 mm) shall be provided in front of urinals to allow forward approach. This clear space shall adjoin or overlap an accessible route and shall

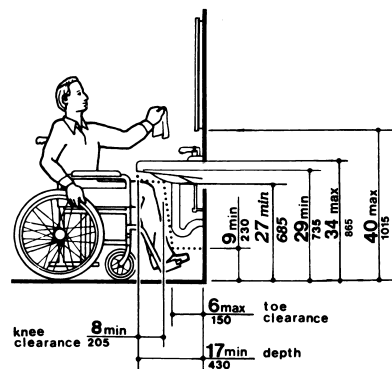

Fig. 31  
Lavatory Clearances

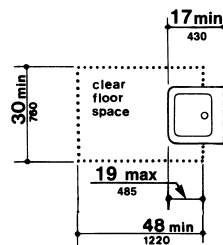

Fig. 32  
Clear Floor Space at Lavatories



**4.19 Lavatories and Mirrors**

<p>comply with 4.2.4. <i>Urinal shields that do not extend beyond the front edge of the urinal rim may be provided with 29 in (735 mm) clearance between them.</i></p> <p><b>4.18.4 Flush Controls.</b> Flush controls shall be hand operated or automatic, and shall comply with 4.27.4, and shall be mounted no more than 44 in (1120 mm) above the finish floor.</p> <p><b>4.19 Lavatories and Mirrors.</b></p> <p><b>4.19.1 General.</b> The requirements of 4.19 shall apply to lavatory fixtures, vanities, and built-in lavatories.</p> <p><b>4.19.2 Height and Clearances.</b> Lavatories shall be mounted with <i>the rim or counter surface no higher than 34 in (865 mm) above the finish floor.</i> Provide a clearance of at least 29 in (735 mm) above the finish floor to the bottom of the apron. Knee and toe clearance shall comply with Fig. 31.</p> <p><i>EXCEPTION 1: Lavatories used primarily by children ages 6 through 12 shall be permitted to have an apron clearance and a knee clearance 24 in (610 mm) high minimum provided that the rim or counter surface is no higher than 31 in (760 mm).</i></p> <p><i>EXCEPTION 2: Lavatories used primarily by children ages 5 and younger shall not be required to meet these clearances if clear floor space for a parallel approach complying with 4.2.4 is provided.</i></p> <p><b>4.19.3 Clear Floor Space.</b> A clear floor space 30 in by 48 in (760 mm by 1220 mm) complying with 4.2.4 shall be provided in front of a lavatory to allow forward approach. Such clear floor space shall adjoin or overlap an accessible route and shall extend a maximum of 19 in (485 mm) underneath the lavatory (see Fig. 32).</p> <p><b>4.19.4 Exposed Pipes and Surfaces.</b> Hot water and drain pipes under lavatories shall be insulated or otherwise <i>configured to protect against contact.</i> There shall be no sharp or abrasive surfaces under lavatories.</p> <p><b>4.19.5 Faucets.</b> Faucets shall comply with 4.27.4. Lever-operated, push-type, and electronically controlled mechanisms are examples of acceptable designs. <i>If self-closing valves are</i></p>	
--	--

44A

**4.20 Bathtubs**

used the faucet *shall remain* open for at least 10 seconds.

**4.19.6\* Mirrors.** Mirrors shall be mounted with the bottom edge of the reflecting surface no higher than 40 in (1015 mm) above the finish floor (see Fig. 31).

**4.20 Bathtubs.**

**4.20.1 General.** Accessible bathtubs shall comply with 4.20.

**4.20.2 Floor Space.** Clear floor space in front of bathtubs shall be as shown in Fig. 33.

**4.20.3 Seat.** An in-tub seat or a seat at the head end of the tub shall be provided as shown in Fig. 33 and 34. The structural strength of seats and their attachments shall comply with 4.26.3. Seats shall be mounted securely and shall not slip during use.

**4.20.4 Grab Bars.** Grab bars complying with 4.26 shall be provided as shown in Fig. 33 and 34.

**4.20.5 Controls.** Faucets and other controls complying with 4.27.4 shall be located as shown in Fig. 34.

**4.20.6 Shower Unit.** A shower spray unit with a hose at least 60 in (1525 mm) long that can be used *both* as a fixed shower head *and* as a hand-held shower shall be provided.

**4.20.7 Bathtub Enclosures.** If provided, enclosures for bathtubs shall not obstruct controls or transfer from wheelchairs onto bathtub seats or into tubs. Enclosures on bathtubs shall not have tracks mounted on their rims.

**4.21 Shower Stalls.**

**4.21.1\* General.** Accessible shower stalls shall comply with 4.21.

**4.21.2 Size and Clearances.** Except as specified in 9.1.2, shower stall size and clear floor space shall comply with Fig. 35(a) or (b). The shower stall in Fig. 35(a) shall be 36 in by 36 in (915 mm by 915 mm). Shower stalls required by 9.1.2 shall comply with Fig. 57(a)

or (b). The shower stall in Fig. 35(b) will fit into the space required for a bathtub.

**4.21.3 Seat.** A seat shall be provided in shower stalls 36 in by 36 in (915 mm by 915 mm) and shall be as shown in Fig. 36. The seat shall be mounted 17 in to 19 in (430 mm to 485 mm) from the bathroom floor and shall extend the full depth of the stall. In a 36 in by 36 in (915 mm by 915 mm) shower stall, the seat shall be on the wall opposite the controls. *Where a fixed seat is provided in a 30 in by 60 in minimum (760 mm by 1525 mm) shower stall, it shall be a folding type and shall be mounted on the wall adjacent to the controls as shown in Fig. 57.* The structural strength of seats and their attachments shall comply with 4.26.3.

**4.21.4 Grab Bars.** Grab bars complying with 4.26 shall be provided as shown in Fig. 37.

**4.21.5 Controls.** Faucets and other controls complying with 4.27.4 shall be located as shown in Fig. 37. In shower stalls 36 in by 36 in (915 mm by 915 mm), all controls, faucets, and the shower unit shall be mounted on the side wall opposite the seat.

**4.21.6 Shower Unit.** A shower spray unit with a hose at least 60 in (1525 mm) long that can be used *both* as a fixed shower head *and* as a hand-held shower shall be provided.

*EXCEPTION: In unmonitored facilities where vandalism is a consideration, a fixed shower head mounted at 48 in (1220 mm) above the shower floor may be used in lieu of a hand-held shower head.*

**4.21.7 Curbs.** If provided, curbs in shower stalls 36 in by 36 in (915 mm by 915 mm) shall be no higher than 1/2 in (13 mm). Shower stalls that are 30 in by 60 in (760 mm by 1525 mm) minimum shall not have curbs.

**4.21.8 Shower Enclosures.** If provided, enclosures for shower stalls shall not obstruct controls or obstruct transfer from wheelchairs onto shower seats.

**4.22 Toilet Rooms.**

**4.22.1 Minimum Number.** *Toilet facilities required to be accessible by 4.1 shall comply*

4.21 Shower Stalls

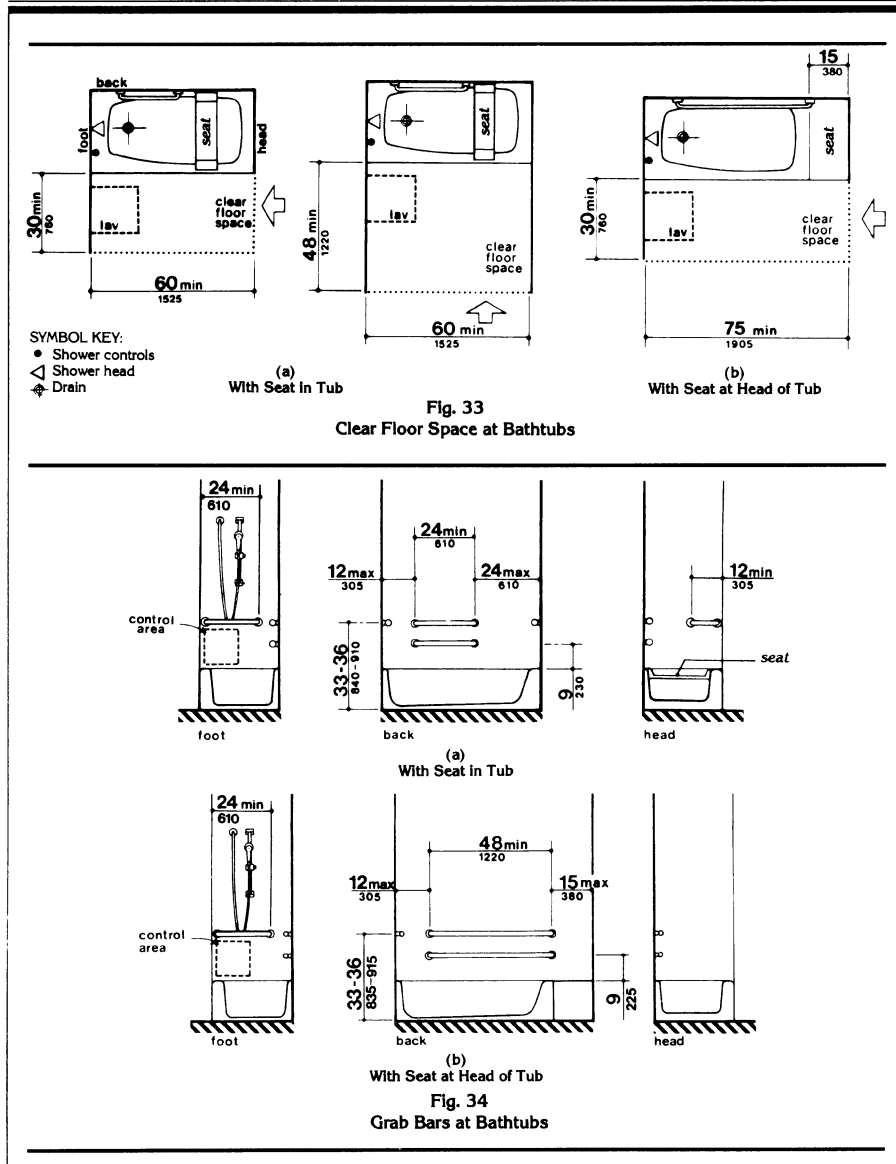

**4.22 Toilet Rooms**

with 4.22. Accessible toilet rooms shall be on an accessible route.

**4.22.2 Doors.** All doors to accessible toilet rooms shall comply with 4.13. Doors shall not swing into the clear floor space required for any fixture.

**4.22.3\* Clear Floor Space.** The accessible fixtures and controls required in 4.22.4, 4.22.5, 4.22.6, and 4.22.7 shall be on an accessible route. An unobstructed turning space complying with 4.2.3 shall be provided within an accessible toilet room. The clear floor space at fixtures and controls, the accessible route, and the turning space may overlap.

**4.22.4 Water Closets.** If toilet stalls are provided, then at least one shall be a standard

toilet stall complying with 4.17; where 6 or more stalls are provided, in addition to the stall complying with 4.17.3, at least one stall 36 in (915 mm) wide with an outward swinging, self-closing door and parallel grab bars complying with Fig. 30(d) and 4.26 shall be provided. Water closets in such stalls shall comply with 4.16. If water closets are not in stalls, then at least one shall comply with 4.16.

**4.22.5 Urinals.** If urinals are provided, then at least one shall comply with 4.18.

**4.22.6 Lavatories and Mirrors.** If lavatories and mirrors are provided, then at least one of each shall comply with 4.19.

**4.22.7 Controls and Dispensers.** If controls, dispensers, receptacles, or other

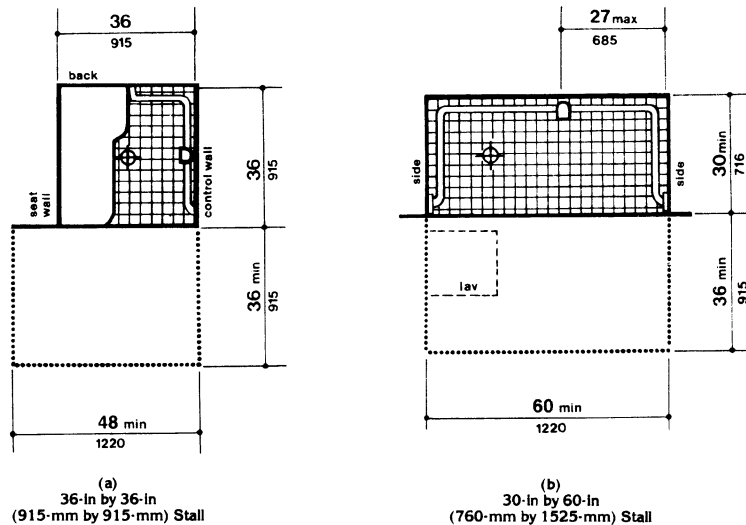
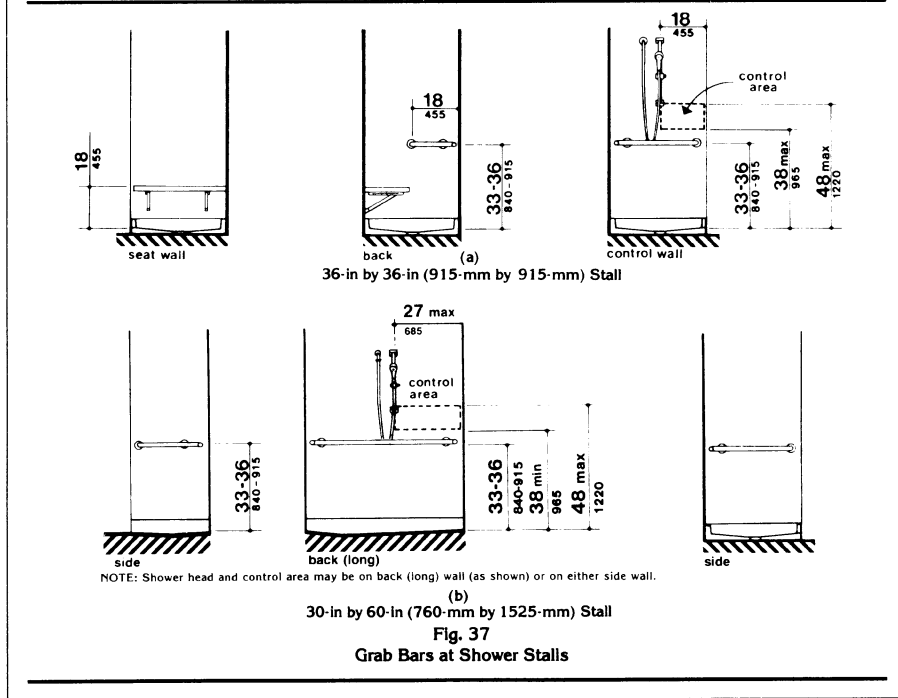
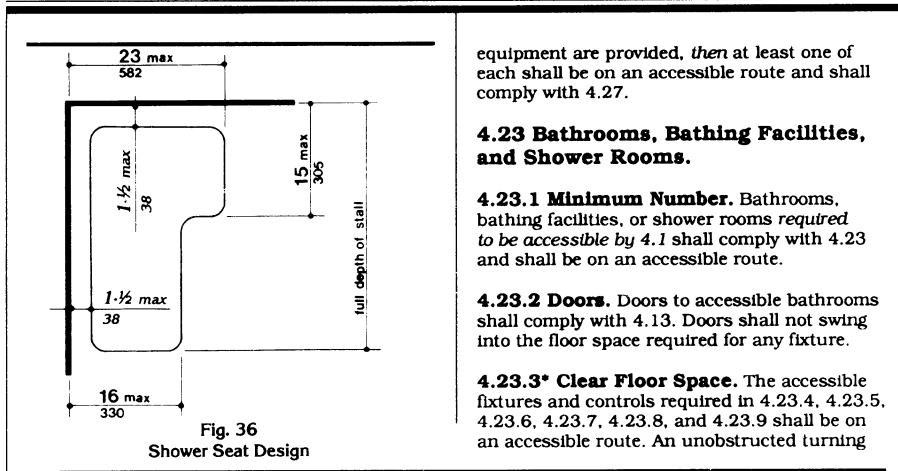

Fig. 35  
Shower Size and Clearances

**4.23 Bathrooms, Bathing Facilities, and Shower Rooms**



## 4.24 Sinks

space complying with 4.2.3 shall be provided within an accessible bathroom. The clear floor spaces at fixtures and controls, the accessible route, and the turning space may overlap.

**4.23.4 Water Closets.** If toilet stalls are provided, then at least one shall be a standard toilet stall complying with 4.17; *where 6 or more stalls are provided, in addition to the stall complying with 4.17.3, at least one stall 36 in (915 mm) wide with an outward swinging, self-closing door and parallel grab bars complying with Fig. 30(d) and 4.26 shall be provided.* Water closets in such stalls shall comply with 4.16. If water closets are not in stalls, then at least one shall comply with 4.16.

**4.23.5 Urinals.** If urinals are provided, then at least one shall comply with 4.18.

**4.23.6 Lavatories and Mirrors.** If lavatories and mirrors are provided, then at least one of each shall comply with 4.19.

**4.23.7 Controls and Dispensers.** If controls, dispensers, receptacles, or other equipment are provided, then at least one of each shall be on an accessible route and shall comply with 4.27.

**4.23.8 Bathing and Shower Facilities.** If tubs or showers are provided, then at least one accessible tub that complies with 4.20 or at least one accessible shower that complies with 4.21 shall be provided.

**4.23.9\* Medicine Cabinets.** If medicine cabinets are provided, at least one shall be located with a usable shelf no higher than 44 in (1120 mm) above the floor space. The floor space shall comply with 4.2.4.

#### 4.24 Sinks.

**4.24.1 General.** Sinks *required to be accessible by 4.1* shall comply with 4.24.

**4.24.2 Height.** Sinks shall be mounted with the counter or rim no higher than 34 in (865 mm) *above the finish floor.*

**4.24.3 Knee Clearance.** Knee clearance that is at least 27 in (685 mm) high, 30 in (760 mm) wide, and 19 in (485 mm) deep shall be provided underneath sinks.

*EXCEPTION 1: Sinks used primarily by children ages 6 through 12 shall be permitted to have a knee clearance 24 in (610 mm) high minimum provided that the rim or counter surface is no higher than 31 in (760 mm).*

*EXCEPTION 2: Sinks used primarily by children ages 5 and younger shall not be required to provide knee clearance if clear floor space for a parallel approach complying with 4.2.4 is provided.*

**4.24.4 Depth.** Each sink shall be a maximum of 6-1/2 in (165 mm) deep.

**4.24.5 Clear Floor Space.** A clear floor space at least 30 in by 48 in (760 mm by 1220 mm) complying with 4.2.4 shall be provided in front of a sink to allow forward approach. The clear floor space shall be on an accessible route and shall extend a maximum of 19 in (485 mm) underneath the sink (see Fig. 32).

**4.24.6 Exposed Pipes and Surfaces.** Hot water and drain pipes exposed under sinks shall be insulated or otherwise *configured so as to protect against contact.* There shall be no sharp or abrasive surfaces under sinks.

**4.24.7 Faucets.** Faucets shall comply with 4.27.4. Lever-operated, push-type, touch-type, or electronically controlled mechanisms are acceptable designs.

#### 4.25 Storage.

**4.25.1 General.** *Fixed storage facilities such as cabinets, shelves, closets, and drawers required to be accessible by 4.1* shall comply with 4.25.

**4.25.2 Clear Floor Space.** A clear floor space at least 30 in by 48 in (760 mm by 1220 mm) complying with 4.2.4 that allows either a forward or parallel approach by a person using a wheelchair shall be provided at accessible storage facilities.

**4.25.3\* Height.** Accessible storage spaces shall be within at least one of the reach ranges specified in 4.2.5 and 4.2.6 (*see Fig. 5 and Fig. 6*). Clothes rods or shelves shall be a maximum of 54 in (1370 mm) *above the finish floor for a side approach. Where the distance from the wheelchair to the clothes rod or shelf exceeds 10 in (255 mm) (as in closets without*

4.26 Handrails, Grab Bars, and Tub and Shower Seats

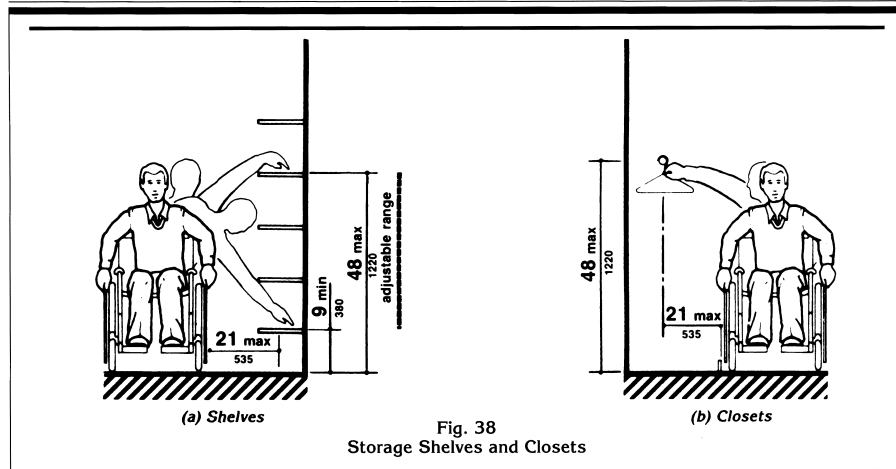

Fig. 38  
Storage Shelves and Closets

accessible doors) the height and depth to the rod or shelf shall comply with Fig. 38(a) and Fig. 38(b).

**4.25.4 Hardware.** Hardware for accessible storage facilities shall comply with 4.27.4. Touch latches and U-shaped pulls are acceptable.

**4.26 Handrails, Grab Bars, and Tub and Shower Seats.**

**4.26.1\* General.** All handrails, grab bars, and tub and shower seats required to be accessible by 4.1, 4.8, 4.9, 4.16, 4.17, 4.20 or 4.21 shall comply with 4.26.

**4.26.2\* Size and Spacing of Grab Bars and Handrails.** The diameter or width of the gripping surfaces of a handrail or grab bar shall be 1-1/4 in to 1-1/2 in (32 mm to 38 mm), or the shape shall provide an equivalent gripping surface. If handrails or grab bars are mounted adjacent to a wall, the space between the wall and the grab bar shall be 1-1/2 in (38 mm) (see Fig. 39(a), (b), (c), and (e)). Handrails may be located in a recess if the recess is a maximum of 3 in (75 mm) deep and extends at least 18 in (455 mm) above the top of the rail (see Fig. 39(d)).

**4.26.3 Structural Strength.** The structural strength of grab bars, tub and shower seats, fasteners, and mounting devices shall meet the following specification:

(1) Bending stress in a grab bar or seat induced by the maximum bending moment from the application of 250 lbf (1112N) shall be less than the allowable stress for the material of the grab bar or seat.

(2) Shear stress induced in a grab bar or seat by the application of 250 lbf (1112N) shall be less than the allowable shear stress for the material of the grab bar or seat. If the connection between the grab bar or seat and its mounting bracket or other support is considered to be fully restrained, then direct and torsional shear stresses shall be totaled for the combined shear stress, which shall not exceed the allowable shear stress.

(3) Shear force induced in a fastener or mounting device from the application of 250 lbf (1112N) shall be less than the allowable lateral load of either the fastener or mounting device or the supporting structure, whichever is the smaller allowable load.

(4) Tensile force induced in a fastener by a direct tension force of 250 lbf (1112N) plus the maximum moment from the application of 250 lbf (1112N) shall be less than the allowable withdrawal load between the fastener and the supporting structure.

(5) Grab bars shall not rotate within their fittings.

4.26 Handrails, Grab Bars, and Tub and Shower Seats

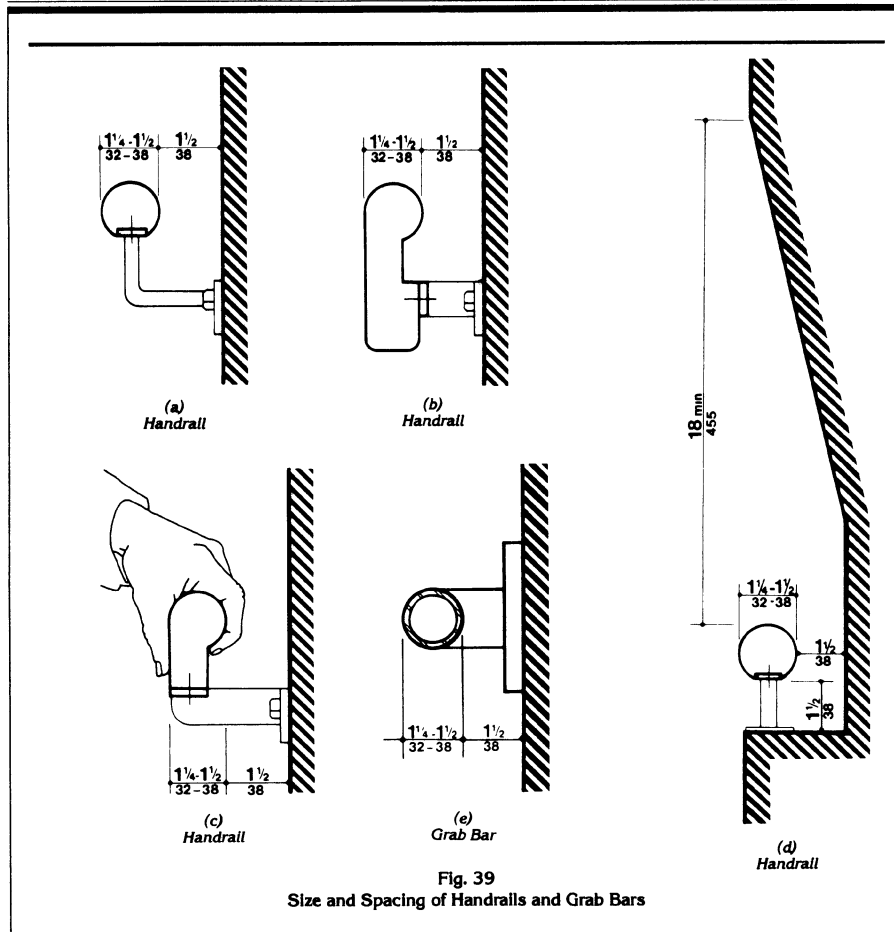

Fig. 39  
Size and Spacing of Handrails and Grab Bars

**4.26.4 Eliminating Hazards.** A handrail or grab bar and any wall or other surface adjacent to it shall be free of any sharp or abrasive elements. Edges shall have a minimum radius of 1/8 in (3.2 mm).

**4.27 Controls and Operating Mechanisms.**

**4.27.1 General.** Controls and operating mechanisms required to be accessible by 4.1 shall comply with 4.27.



**4.28 Alarms**

<p><b>4.27.2 Clear Floor Space.</b> Clear floor space complying with 4.2.4 that allows a forward or a parallel approach by a person using a wheelchair shall be provided at controls, dispensers, receptacles, and other operable equipment.</p> <p><b>4.27.3* Height.</b> The highest operable part of controls, dispensers, receptacles, and other operable equipment shall be placed within at least one of the reach ranges specified in 4.2.5 and 4.2.6. Electrical and communications system receptacles on walls shall be mounted no less than 15 in (380 mm) above the floor.</p> <p><i>EXCEPTION: These requirements do not apply where the use of special equipment dictates otherwise or where electrical and communications systems receptacles are not normally intended for use by building occupants.</i></p> <p><b>4.27.4 Operation.</b> Controls and operating mechanisms shall be operable with one hand and shall not require tight grasping, pinching, or twisting of the wrist. The force required to activate controls shall be no greater than 5 lbf (22.2 N).</p> <p><b>4.28 Alarms.</b></p> <p><b>4.28.1 General.</b> Alarm systems required to be accessible by 4.1 shall comply with 4.28. At a minimum, visual signal appliances shall be provided in buildings and facilities in each of the following areas: restrooms and any other general usage areas (e.g., meeting rooms), hallways, lobbies, and any other area for common use.</p> <p><b>4.28.2* Audible Alarms.</b> If provided, audible emergency alarms shall produce a sound that exceeds the prevailing equivalent sound level in the room or space by at least 15 dbA or exceeds any maximum sound level with a duration of 60 seconds by 5 dbA, whichever is louder. Sound levels for alarm signals shall not exceed 120 dbA.</p> <p><b>4.28.3* Visual Alarms.</b> Visual alarm signal appliances shall be integrated into the building or facility alarm system. If single station audible alarms are provided then single station visual alarm signals shall be provided. Visual alarm signals shall have the following minimum photometric and location features:</p>	<p>(1) The lamp shall be a xenon strobe type or equivalent.</p> <p>(2) The color shall be clear or nominal white (i.e., unfiltered or clear filtered white light).</p> <p>(3) The maximum pulse duration shall be two-tenths of one second (0.2 sec) with a maximum duty cycle of 40 percent. The pulse duration is defined as the time interval between initial and final points of 10 percent of maximum signal.</p> <p>(4) The intensity shall be a minimum of 75 candela.</p> <p>(5) The flash rate shall be a minimum of 1 Hz and a maximum of 3 Hz.</p> <p>(6) The appliance shall be placed 80 in (2030 mm) above the highest floor level within the space or 6 in (152 mm) below the ceiling, whichever is lower.</p> <p>(7) In general, no place in any room or space required to have a visual signal appliance shall be more than 50 ft (15 m) from the signal (in the horizontal plane). In large rooms and spaces exceeding 100 ft (30 m) across, without obstructions 6 ft (2 m) above the finish floor, such as auditoriums, devices may be placed around the perimeter, spaced a maximum 100 ft (30 m) apart, in lieu of suspending appliances from the ceiling.</p> <p>(8) No place in common corridors or hallways in which visual alarm signalling appliances are required shall be more than 50 ft (15 m) from the signal.</p> <p><b>4.28.4* Auxiliary Alarms.</b> Units and sleeping accommodations shall have a visual alarm connected to the building emergency alarm system or shall have a standard 110-volt electrical receptacle into which such an alarm can be connected and a means by which a signal from the building emergency alarm system can trigger such an auxiliary alarm. When visual alarms are in place the signal shall be visible in all areas of the unit or room. Instructions for use of the auxiliary alarm or receptacle shall be provided.</p>
--	--

**4.29 Detectable Warnings**

**4.29 Detectable Warnings.**

**4.29.1 General.** Detectable warnings required by 4.1 and 4.7 shall comply with 4.29.

**4.29.2\* Detectable Warnings on Walking Surfaces.** Detectable warnings shall consist of raised truncated domes with a diameter of nominal 0.9 in (23 mm), a height of nominal 0.2 in (5 mm) and a center-to-center spacing of nominal 2.35 in (60 mm) and shall contrast visually with adjoining surfaces, either light-on-dark, or dark-on-light.

*The material used to provide contrast shall be an integral part of the walking surface. Detectable warnings used on interior surfaces shall differ from adjoining walking surfaces in resiliency or sound-on-cane contact.*

**4.29.3 Detectable Warnings on Doors To Hazardous Areas.** (Reserved).

**4.29.4 Detectable Warnings at Stairs.** (Reserved).

**4.29.5 Detectable Warnings at Hazardous Vehicular Areas.** If a walk crosses or adjoins a vehicular way, and the walking surfaces are not separated by curbs, railings, or other elements between the pedestrian areas and vehicular areas, the boundary between the areas shall be defined by a continuous detectable warning which is 36 in (915 mm) wide, complying with 4.29.2.

**4.29.6 Detectable Warnings at Reflecting Pools.** The edges of reflecting pools shall be protected by railings, walls, curbs, or detectable warnings complying with 4.29.2.

**4.29.7 Standardization.** (Reserved).

**4.30 Signage.**

**4.30.1\* General.** Signage required to be accessible by 4.1 shall comply with the applicable provisions of 4.30.

**4.30.2\* Character Proportion.** Letters and numbers on signs shall have a width-to-height ratio between 3:5 and 1:1 and a stroke-width-to-height ratio between 1:5 and 1:10.

**4.30.3 Character Height.** Characters and numbers on signs shall be sized according to the viewing distance from which they are to be read. The minimum height is measured using an upper case X. Lower case characters are permitted.

Height Above Finished Floor	Minimum Character Height
Suspended or Projected Overhead in compliance with 4.4.2	3 in. (75 mm) minimum

**4.30.4\* Raised and Brailled Characters and Pictorial Symbol Signs (Pictograms).**

Letters and numerals shall be raised 1/32 in, upper case, sans serif or simple serif type and shall be accompanied with Grade 2 Braille. Raised characters shall be at least 5/8 in (16 mm) high, but no higher than 2 in (50 mm). Pictograms shall be accompanied by the equivalent verbal description placed directly below the pictogram. The border dimension of the pictogram shall be 6 in (152 mm) minimum in height.

**4.30.5\* Finish and Contrast.** The characters and background of signs shall be eggshell, matte, or other non-glare finish. Characters and symbols shall contrast with their background — either light characters on a dark background or dark characters on a light background.

**4.30.6 Mounting Location and Height.**

Where permanent identification is provided for rooms and spaces, signs shall be installed on the wall adjacent to the latch side of the door. Where there is no wall space to the latch side of the door, including at double leaf doors, signs shall be placed on the nearest adjacent wall. Mounting height shall be 60 in (1525 mm) above the finish floor to the centerline of the sign. Mounting location for such signage shall be so that a person may approach within 3 in (76 mm) of signage without encountering protruding objects or standing within the swing of a door.

**4.30.7\* Symbols of Accessibility.**

(1) Facilities and elements required to be identified as accessible by 4.1 shall use the international symbol of accessibility. The

4.30 Signage

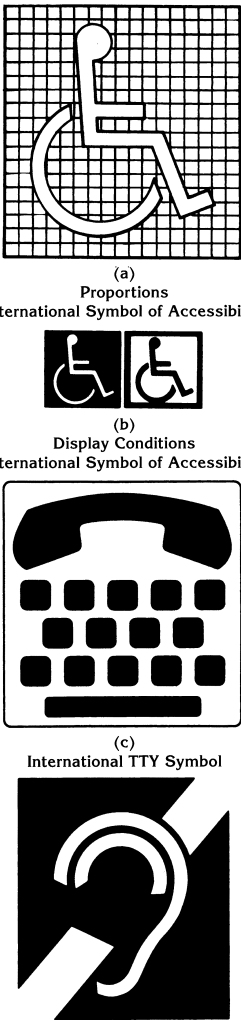
 <p>(a) Proportions International Symbol of Accessibility</p> <p>(b) Display Conditions International Symbol of Accessibility</p> <p>(c) International TTY Symbol</p> <p>(d) International Symbol of Access for Hearing Loss</p> <p>Fig. 43 International Symbols</p>	<p>symbol shall be displayed as shown in Fig. 43(a) and (b).</p> <p>(2) <i>Volume Control Telephones.</i> Telephones required to have a volume control by 4.1.3(17)(b) shall be identified by a sign containing a depiction of a telephone handset with radiating sound waves.</p> <p>(3) <i>Text Telephones (TTYs).</i> Text telephones (TTYs) required by 4.1.3 (17)(c) shall be identified by the international TTY symbol (Fig 43(c)). In addition, if a facility has a public text telephone (TTY), directional signage indicating the location of the nearest text telephone (TTY) shall be placed adjacent to all banks of telephones which do not contain a text telephone (TTY). Such directional signage shall include the international TTY symbol. If a facility has no banks of telephones, the directional signage shall be provided at the entrance (e.g., in a building directory).</p> <p>(4) <i>Assistive Listening Systems.</i> In assembly areas where permanently installed assistive listening systems are required by 4.1.3(19)(b) the availability of such systems shall be identified with signage that includes the international symbol of access for hearing loss (Fig 43(d)).</p> <p><b>4.30.8* Illumination Levels.</b> (Reserved).</p> <p><b>4.31 Telephones.</b></p> <p><b>4.31.1 General.</b> Public telephones required to be accessible by 4.1 shall comply with 4.31.</p> <p><b>4.31.2 Clear Floor or Ground Space.</b> A clear floor or ground space at least 30 in by 48 in (760 mm by 1220 mm) that allows either a forward or parallel approach by a person using a wheelchair shall be provided at telephones (see Fig. 44). The clear floor or ground space shall comply with 4.2.4. Bases, enclosures, and fixed seats shall not impede approaches to telephones by people who use wheelchairs.</p> <p><b>4.31.3* Mounting Height.</b> The highest operable part of the telephone shall be within the reach ranges specified in 4.2.5 or 4.2.6.</p> <p><b>4.31.4 Protruding Objects.</b> Telephones shall comply with 4.4.</p>
---	---

**4.31 Telephones**

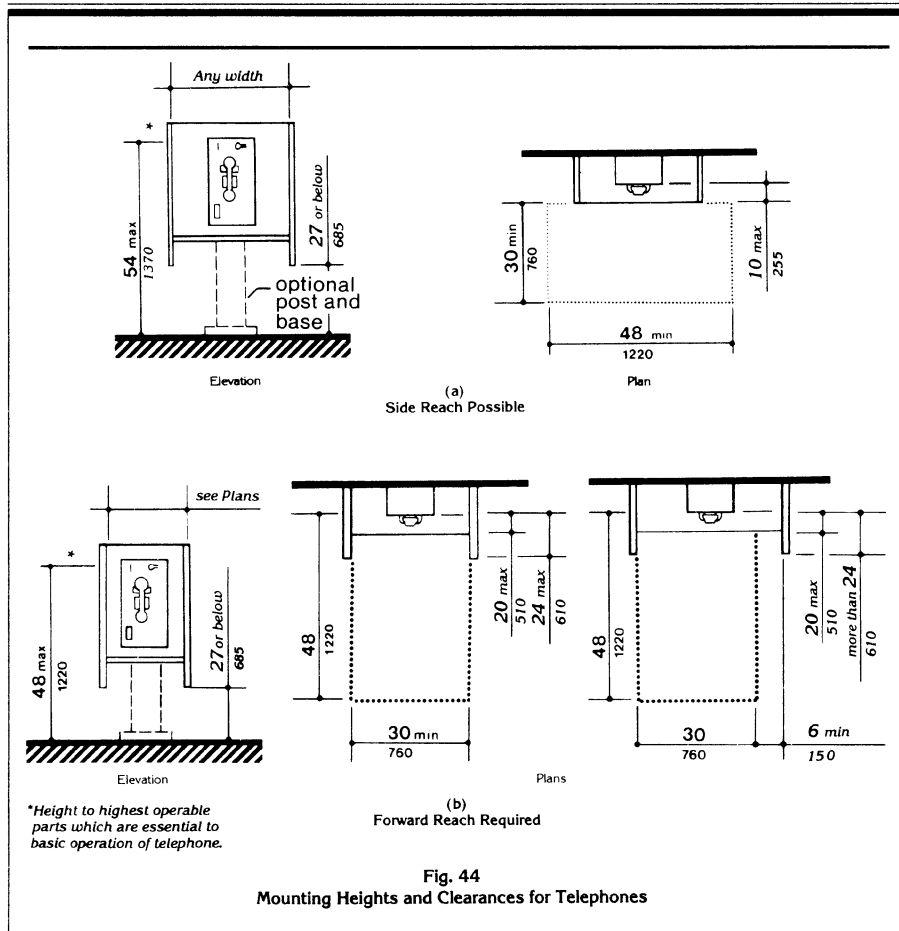

**4.31.5 Hearing Aid Compatible and Volume Control Telephones Required by 4.1.**

- (1) Telephones shall be hearing aid compatible.
- (2) Volume controls, capable of a minimum of 12 dbA and a maximum of 18 dbA above

normal, shall be provided in accordance with 4.1.3. If an automatic reset is provided then 18 dbA may be exceeded.

**4.31.6 Controls.** Telephones shall have pushbutton controls where service for such equipment is available.

**4.32 Fixed or Built-in Seating and Tables**

<p><b>4.31.7 Telephone Books.</b> Telephone books, if provided, shall be located in a position that complies with the reach ranges specified in 4.2.5 and 4.2.6.</p> <p><b>4.31.8 Cord Length.</b> The cord from the telephone to the handset shall be at least 29 in (735 mm) long.</p> <p><b>4.31.9* Text Telephones (TTYs) Required by 4.1.</b></p> <p>(1) Text telephones (TTYs) used with a pay telephone shall be permanently affixed within, or adjacent to, the telephone enclosure. If an acoustic coupler is used, the telephone cord shall be sufficiently long to allow connection of the text telephone (TTY) and the telephone receiver.</p> <p>(2) Pay telephones designed to accommodate a portable text telephone (TTY) shall be equipped with a shelf and an electrical outlet within or adjacent to the telephone enclosure. The telephone handset shall be capable of being placed flush on the surface of the shelf. The shelf shall be capable of accommodating a text telephone (TTY) and shall have 6 in (152 mm) minimum vertical clearance in the area where the text telephone (TTY) is to be placed.</p> <p>(3) Equivalent facilitation may be provided. For example, a portable text telephone (TTY) may be made available in a hotel at the registration desk if it is available on a 24-hour basis for use with nearby public pay telephones. In this instance, at least one pay telephone shall comply with paragraph 2 of this section. In addition, if an acoustic coupler is used, the telephone handset cord shall be sufficiently long so as to allow connection of the text telephone (TTY) and the telephone receiver. Directional signage shall be provided and shall comply with 4.30.7.</p> <p><b>4.32 Fixed or Built-in Seating and Tables.</b></p> <p><b>4.32.1 Minimum Number.</b> Fixed or built-in seating or tables required to be accessible by 4.1 shall comply with 4.32.2 through 4.32.4.</p> <p><i>EXCEPTION: Fixed or built-in seating or tables used primarily by children ages 12 and younger shall be permitted to comply with 4.32.5.</i></p>	<p><b>4.32.2 Seating.</b> If seating spaces for people in wheelchairs are provided at fixed tables or counters, clear floor space complying with 4.2.4 shall be provided. Such clear floor space shall not overlap knee space by more than 19 in (485 mm) (see Fig. 45).</p> <p><b>4.32.3 Knee Clearances.</b> If seating for people in wheelchairs is provided at tables or counters, knee spaces at least 27 in (685 mm) high, 30 in (760 mm) wide, and 19 in (485 mm) deep shall be provided (see Fig. 45).</p> <p><b>4.32.4* Height of Tables or Counters.</b> The tops of accessible tables and counters shall be from 28 in to 34 in (710 mm to 865 mm) above the finish floor or ground.</p> <p><b>4.32.5 Children's Fixed or Built-in Seating and Tables.</b> Fixed or built-in seating or tables used primarily by children ages 12 and younger shall comply with 4.32.5 as permitted by 4.32.1.</p> <p><i>EXCEPTION: Fixed or built-in seating or tables used primarily by children ages 5 and younger shall not be required to comply with 4.32.5 if clear floor space complying with 4.2.4 parallel to fixed tables or counters is provided.</i></p> <p>(1) Seating. If seating spaces for people in wheelchairs are provided at fixed tables or counters, clear floor space complying with 4.2.4 shall be provided. Such clear floor space shall not overlap knee space by more than 19 in (485 mm) (see Fig. 45).</p> <p>(2) Knee Clearances. If seating for people in wheelchairs is provided at tables or counters, knee spaces at least 24 in (610 mm) high, 30 in (760 mm) wide, and 19 in (485 mm) deep shall be provided (see Fig. 45).</p> <p>(3) Height of Tables or Counters. The tops of accessible tables and counters shall be from 26 in to 30 in (660 mm to 760 mm) above the finish floor or ground.</p> <p><b>4.33 Assembly Areas.</b></p> <p><b>4.33.1 Minimum Number.</b> Assembly and associated areas required to be accessible by 4.1 shall comply with 4.33.</p>
---	--

4.33 Assembly Areas

<p><b>4.33.2* Size of Wheelchair Locations.</b> Each wheelchair location shall provide minimum clear ground or floor spaces as shown in Fig. 46.</p> <p><b>4.33.3* Placement of Wheelchair Locations.</b> Wheelchair areas shall be an integral part of any fixed seating plan and shall be provided so as to provide people with physical disabilities a choice of admission prices and lines of sight comparable to those for members of the general public. They shall adjoin an accessible route that also serves as a means of egress in case of emergency. <i>At least one companion fixed seat shall be provided next to each wheelchair seating area. When the seating capacity exceeds 300, wheelchair spaces shall be provided in more than one location. Readily removable seats may be installed in wheelchair spaces when the spaces are not required to accommodate wheelchair users.</i></p> <p><i>EXCEPTION: Accessible viewing positions may be clustered for bleachers, balconies, and other areas having sight lines that require slopes of greater than 5 percent. Equivalent accessible viewing positions may be located on levels having accessible egress.</i></p> <p><b>4.33.4 Surfaces.</b> The ground or floor at wheelchair locations shall be level and shall comply with 4.5.</p>	
--	--

4.33 Assembly Areas

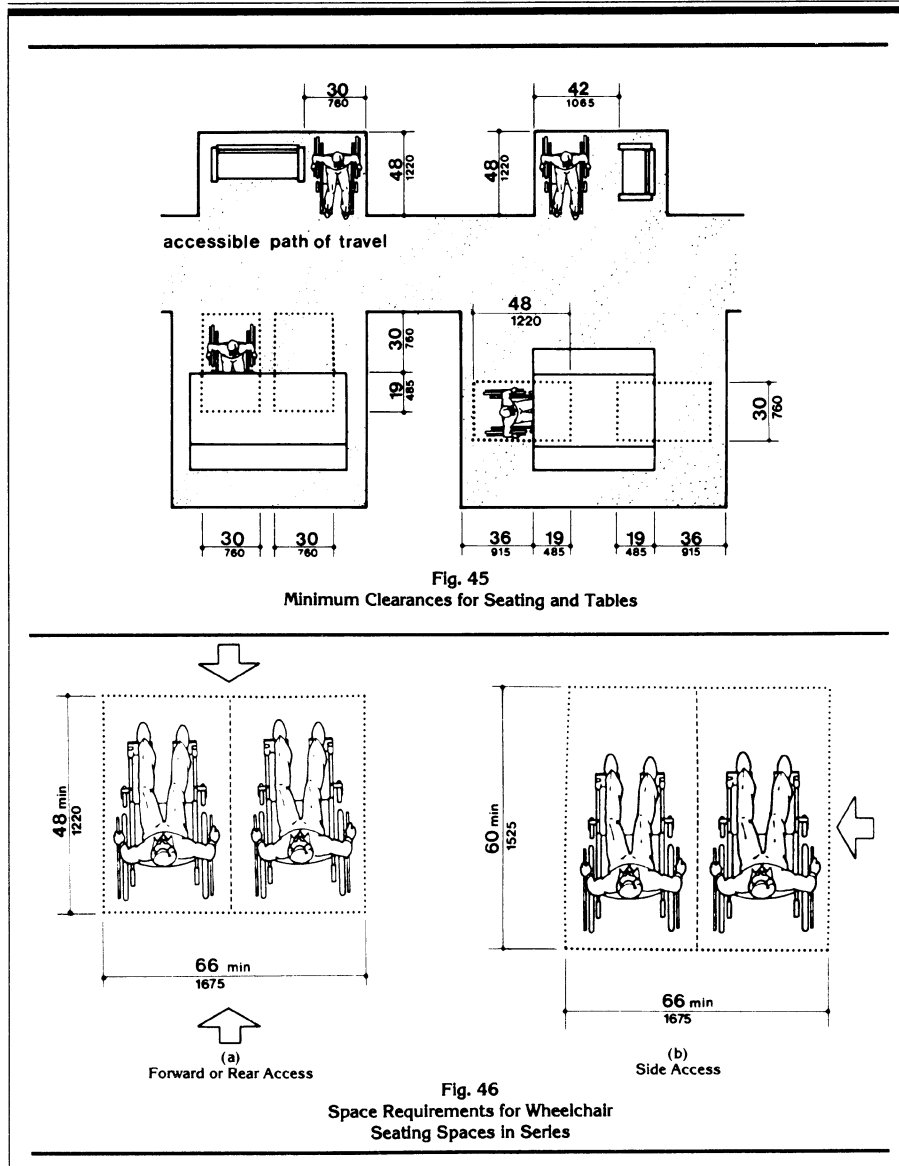

**4.33.5 Access to Performing Areas**

**4.33.5 Access to Performing Areas.**

An accessible route shall connect wheelchair seating locations with performing areas, including stages, arena floors, dressing rooms, locker rooms, and other spaces used by performers.

**4.33.6\* Placement of Listening Systems.**

If the listening system provided serves individual fixed seats, then such seats shall be located within a 50 ft (15 m) viewing distance of the stage or playing area and shall have a complete view of the stage or playing area.

**4.33.7\* Types of Listening Systems.**

Assistive listening systems (ALS) are intended to augment standard public address and audio systems by providing signals which can be received directly by persons with special receivers or their own hearing aids and which eliminate or filter background noise. The type of assistive listening system appropriate for a particular application depends on the characteristics of the setting, the nature of the program, and the intended audience. Magnetic induction loops, infra-red and radio frequency systems are types of listening systems which are appropriate for various applications.

**4.34 Automated Teller Machines.**

**4.34.1 General.** Each automated teller machine required to be accessible by 4.1.3 shall be on an accessible route and shall comply with 4.34.

**4.34.2 Clear Floor Space.** The automated teller machine shall be located so that clear floor space complying with 4.2.4 is provided to allow a person using a wheelchair to make a forward approach, a parallel approach, or both, to the machine.

**4.34.3 Reach Ranges.**

(1) *Forward Approach Only.* If only a forward approach is possible, operable parts of all controls shall be placed within the forward reach range specified in 4.2.5.

(2) *Parallel Approach Only.* If only a parallel approach is possible, operable parts of controls shall be placed as follows:

(a) *Reach Depth Not More Than 10 in (255 mm).* Where the reach depth to the operable parts of all controls as measured from the vertical plane perpendicular to the edge of the unobstructed clear floor space at the farthest

*protrusion of the automated teller machine or surround is not more than 10 in (255 mm), the maximum height above the finished floor or grade shall be 54 in (1370 mm).*

(b) *Reach Depth More Than 10 in (255 mm).* Where the reach depth to the operable parts of any control as measured from the vertical plane perpendicular to the edge of the unobstructed clear floor space at the farthest protrusion of the automated teller machine or surround is more than 10 in (255 mm), the maximum height above the finished floor or grade shall be as follows:

Reach Depth		Maximum Height	
<u>In</u>	<u>Mm</u>	<u>In</u>	<u>Mm</u>
10	255	54	1370
11	280	53½	1360
12	305	53	1345
13	330	52½	1335
14	355	51½	1310
15	380	51	1295
16	405	50½	1285
17	430	50	1270
18	455	49½	1255
19	485	49	1245
20	510	48½	1230
21	535	47½	1205
22	560	47	1195
23	585	46½	1180
24	610	46	1170

(3) *Forward and Parallel Approach.* If both a forward and parallel approach are possible, operable parts of controls shall be placed within at least one of the reach ranges in paragraphs (1) or (2) of this section.

(4) *Bins.* Where bins are provided for envelopes, waste paper, or other purposes, at least one of each type provided shall comply with the applicable reach ranges in paragraph (1), (2), or (3) of this section.

**EXCEPTION:** Where a function can be performed in a substantially equivalent manner by using an alternate control, only one of the controls needed to perform that function is required to comply with this section. If the controls are identified by tactile markings, such markings shall be provided on both controls.

**4.34.4 Controls.** Controls for user activation shall comply with 4.27.4.



4.35 Dressing, Fitting, and Locker Rooms

**4.34.5 Equipment for Persons with Vision Impairments.** Instructions and all information for use shall be made accessible to and independently usable by persons with vision impairments.

**4.35 Dressing, Fitting, and Locker Rooms.**

**4.35.1 General.** Dressing, fitting, and locker rooms required to be accessible by 4.1 shall comply with 4.35 and shall be on an accessible route.

**4.35.2 Clear Floor Space.** A clear floor space allowing a person using a wheelchair to make a 180-degree turn shall be provided in every accessible dressing room entered through a swinging or sliding door. No door shall swing into any part of the turning space. Turning space shall not be required in a private dressing room entered through a curtained opening at least 32 in (815 mm) wide if clear floor space complying with section 4.2 renders the dressing room usable by a person using a wheelchair.

**4.35.3 Doors.** All doors to accessible dressing rooms shall be in compliance with section 4.13.

**4.35.4 Bench.** A bench complying with 4.37 shall be provided within the room.

**4.35.5 Mirror.** Where mirrors are provided in dressing rooms of the same use, then in an accessible dressing room, a full-length mirror, measuring at least 18 in wide by 54 in high (460 mm by 1370 mm), shall be mounted in a position affording a view to a person on the bench as well as to a person in a standing position.

**4.36 Saunas and Steam Rooms.**

**4.36.1 General.** Saunas and steam rooms required to be accessible by 4.1 shall comply with 4.36.

**4.36.2\* Wheelchair Turning Space.** A wheelchair turning space complying with 4.2.3 shall be provided within the room.

*EXCEPTION:* Wheelchair turning space shall be permitted to be obstructed by readily removable seats.

**4.36.3 Sauna and Steam Room Bench.** Where seating is provided, at least one bench shall be provided and shall comply with 4.37.

**4.36.4 Door Swing.** Doors shall not swing into any part of the clear floor or ground space required at a bench complying with 4.37.

**4.37 Benches.**

**4.37.1 General.** Benches required to be accessible by 4.1 shall comply with 4.37.

**4.37.2 Clear Floor or Ground Space.** Clear floor or ground space complying with 4.2.4 shall be provided and shall be positioned for parallel approach to a short end of a bench seat.

*EXCEPTION:* Clear floor or ground space required by 4.37.2 shall be permitted to be obstructed by readily removable seats in saunas and steam rooms.

**4.37.3\* Size.** Benches shall be fixed and shall have seats that are 20 inches (510 mm) minimum to 24 inches (610 mm) maximum in depth and 42 inches (1065 mm) minimum in length (see Fig. 47).

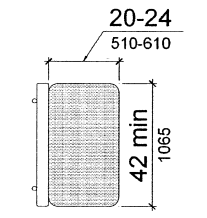

Fig. 47  
Size of Bench

**4.37 Benches**

**4.37.4 Back Support.** Benches shall have back support that is 42 inches (1065 mm) minimum in length and that extends from a point 2 inches (51 mm) maximum above the seat to a point 18 inches (455 mm) minimum above the seat (see Fig. 48).

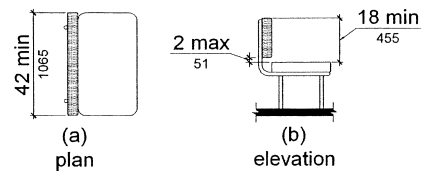

Fig. 48  
Bench Back Support

**4.37.5 Seat Height.** Bench seats shall be 17 inches (430 mm) minimum to 19 inches (485 mm) maximum above the floor or ground.

**4.37.6 Structural Strength.** Allowable stresses shall not be exceeded for materials used when a vertical or horizontal force of 250 lbs. (1112 N) is applied at any point on the seat, fastener, mounting device, or supporting structure.

**4.37.7 Wet Locations.** The surface of benches installed in wet locations shall be slip-resistant and shall not accumulate water.

5.0 Restaurants And Cafeterias

**5. RESTAURANTS AND CAFETERIAS.**

**5.1\* General.** Except as specified or modified in this section, restaurants and cafeterias shall comply with the requirements of section 4. Where fixed tables (or dining counters where food is consumed but there is no service) are provided, at least five percent, but not less than one, of the fixed tables (or a portion of the dining counter) shall be accessible and shall comply with 4.32 as required in 4.1.3(18). In establishments where separate areas are designated for smoking and non-smoking patrons, the required number of accessible fixed tables (or counters) shall be proportionally distributed between the smoking and non-smoking areas. In new construction, and where practicable in alterations, accessible fixed tables (or counters) shall be distributed throughout the space or facility.

**5.2 Counters and Bars.** Where food or drink is served at counters exceeding 34 in (865 mm) in height for consumption by customers seated on stools or standing at the counter, a portion of the main counter which is 60 in (1525 mm) in length minimum shall be provided in compliance with 4.32 or service shall be available at accessible tables within the same area.

**5.3 Access Aisles.** All accessible fixed tables shall be accessible by means of an access aisle at least 36 in (915 mm) clear between parallel edges of tables or between a wall and the table edges.

**5.4 Dining Areas.** In new construction, all dining areas, including raised or sunken dining areas, loggias, and outdoor seating areas, shall be accessible. In non-elevator buildings, an accessible means of vertical access to the mezzanine is not required under the following conditions: 1) the area of mezzanine seating measures no more than 33 percent of the area of the total accessible seating area; 2) the same services and decor are provided in an accessible space usable by the general public; and, 3) the accessible areas are not restricted to use by people with disabilities. In alterations, accessibility to raised or sunken dining areas, or to all parts of outdoor seating areas is not required provided that the same services and decor are provided in an accessible space usable by the general public and are not restricted to use by people with disabilities.

**5.5 Food Service Lines.** Food service lines shall have a minimum clear width of 36 in (915 mm), with a preferred clear width of 42 in (1065 mm) to allow passage around a person using a wheelchair. Tray slides shall be mounted no higher than 34 in (865 mm) above the floor (see Fig. 53). If self-service shelves are provided, at least 50 percent of each type must be within reach ranges specified in 4.2.5 and 4.2.6.

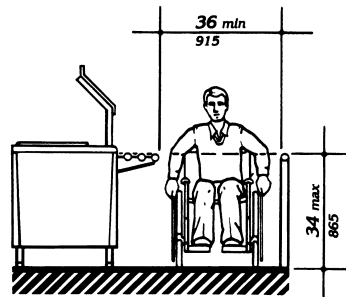

Fig. 53  
Food Service Lines

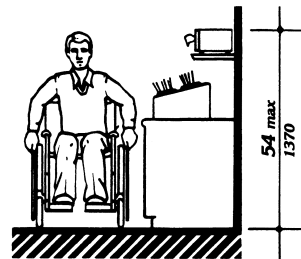

Fig. 54  
Tableware Areas

**6.0 Medical Care Facilities**

**5.6 Tableware and Condiment Areas.** Self-service shelves and dispensing devices for tableware, dishware, condiments, food and beverages shall be installed to comply with 4.2 (see Fig. 54).

**5.7 Raised Platforms.** In banquet rooms or spaces where a head table or speaker's lectern is located on a raised platform, the platform shall be accessible in compliance with 4.8 or 4.11. Open edges of a raised platform shall be protected by placement of tables or by a curb.

**5.8 Vending Machines and Other Equipment.** Spaces for vending machines and other equipment shall comply with 4.2 and shall be located on an accessible route.

**5.9 Quiet Areas.** (Reserved).

**6. MEDICAL CARE FACILITIES.**

**6.1 General.** Medical care facilities included in this section are those in which people receive physical or medical treatment or care and where persons may need assistance in responding to an emergency and where the period of stay may exceed 24 hours. In addition to the requirements of section 4, medical care facilities and buildings shall comply with 6.

(1) Hospitals - general purpose hospitals, psychiatric facilities, detoxification facilities — At least 10 percent of patient bedrooms and toilets, and all public use and common use areas are required to be designed and constructed to be accessible.

(2) Hospitals and rehabilitation facilities that specialize in treating conditions that affect mobility, or units within either that specialize in treating conditions that affect mobility — All patient bedrooms and toilets, and all public use and common use areas are required to be designed and constructed to be accessible.

(3) Long term care facilities, nursing homes — At least 50 percent of patient bedrooms and toilets, and all public use and common use areas are required to be designed and constructed to be accessible.

(4) Alterations to patient bedrooms.

(a) When patient bedrooms are being added or altered as part of a planned renovation of an entire wing, a department, or other discrete area of an existing medical facility, a percentage of the patient bedrooms that are being added or altered shall comply with 6.3. The percentage of accessible rooms provided shall be consistent with the percentage of rooms required to be accessible by the applicable requirements of 6.1(1), 6.1(2), or 6.1(3), until the number of accessible patient bedrooms in the facility equals the overall number that would be required if the facility were newly constructed. (For example, if 20 patient bedrooms are being altered in the obstetrics department of a hospital, 2 of the altered rooms must be made accessible. If, within the same hospital, 20 patient bedrooms are being altered in a unit that specializes in treating mobility impairments, all of the altered rooms must be made accessible.) Where toilet/bath rooms are part of patient bedrooms which are added or altered and required to be accessible, each such patient toilet/bathroom shall comply with 6.4.

(b) When patient bedrooms are being added or altered individually, and not as part of an alteration of the entire area, the altered patient bedrooms shall comply with 6.3, unless either: a) the number of accessible rooms provided in the department or area containing the altered patient bedroom equals the number of accessible patient bedrooms that would be required if the percentage requirements of 6.1(1), 6.1(2), or 6.1(3) were applied to that department or area; or b) the number of accessible patient bedrooms in the facility equals the overall number that would be required if the facility were newly constructed. Where toilet/bathrooms are part of patient bedrooms which are added or altered and required to be accessible, each such toilet/bathroom shall comply with 6.4.

**6.2 Entrances.** At least one accessible entrance that complies with 4.14 shall be protected from the weather by canopy or roof overhang. Such entrances shall incorporate a passenger loading zone that complies with 4.6.6.

**6.3 Patient Bedrooms.** Provide accessible patient bedrooms in compliance with section 4. Accessible patient bedrooms shall comply with the following:

**7.0 Business, Mercantile and Civic**

(1) Each bedroom shall have a door that complies with 4.13.  
 EXCEPTION: Entry doors to acute care hospital bedrooms for in-patients shall be exempted from the requirement in 4.13.6 for maneuvering space at the latch side of the door if the door is at least 44 in (1120 mm) wide.

(2) Each bedroom shall have adequate space to provide a maneuvering space that complies with 4.2.3. In rooms with two beds, it is preferable that this space be located between beds.

(3) Each bedroom shall have adequate space to provide a minimum clear floor space of 36 in (915 mm) along each side of the bed and to provide an accessible route complying with 4.3.3 to each side of each bed.

**6.4 Patient Toilet Rooms.** Where toilet/bathrooms are provided as a part of a patient bedroom, each patient bedroom that is required to be accessible shall have an accessible toilet/bathroom that complies with 4.22 or 4.23 and shall be on an accessible route.

**7. BUSINESS, MERCANTILE AND CIVIC.**

**7.1 General.** In addition to the requirements of section 4, the design of all areas used for business transactions with the public shall comply with 7.

**7.2 Sales and Service Counters, Teller Windows, Information Counters.**

(1) In areas used for transactions where counters have cash registers and are provided for sales or distribution of goods or services to the public, at least one of each type shall have a portion of the counter which is at least 36 in (915 mm) in length with a maximum height of 36 in (915 mm) above the finish floor. It shall be on an accessible route complying with 4.3. Such counters shall include, but are not limited to, counters in retail stores, and distribution centers. The accessible counters must be dispersed throughout the building or facility. In alterations where it is technically infeasible to provide an accessible counter, an auxiliary counter meeting these requirements may be provided.

(2) In areas used for transactions that may not have a cash register but at which goods or services are sold or distributed including, but not limited to, ticketing counters, teller stations, registration counters in transient lodging facilities, information counters, box office counters and library check-out areas, either:

(i) a portion of the main counter which is a minimum of 36 in (915 mm) in length shall be provided with a maximum height of 36 in (915 mm); or

(ii) an auxiliary counter with a maximum height of 36 in (915 mm) in close proximity to the main counter shall be provided; or

(iii) equivalent facilitation shall be provided (e.g., at a hotel registration counter, equivalent facilitation might consist of: (1) provision of a folding shelf attached to the main counter on which an individual with a disability can write, and (2) use of the space on the side of the counter or at the concierge desk, for handing materials back and forth).

All accessible sales and service counters shall be on an accessible route complying with 4.3.

(3) \* In public facilities where counters or teller windows have solid partitions or security glazing to separate personnel from the public, at least one of each type shall provide a method to facilitate voice communication. Such methods may include, but are not limited to, grilles, slats, talk-through baffles, intercoms, or telephone handset devices. The method of communication shall be accessible to both individuals who use wheelchairs and individuals who have difficulty bending or stooping. If provided for public use, at least one telephone communication device shall be equipped with volume controls complying with 4.31.5. Hand-operable communications devices, if provided, shall comply with 4.27.

(4) \* Assistive Listening Systems. (Reserved).

**8.0 Libraries**

**7.3\* Check-out Aisles.**

(1) In new construction, accessible check-out aisles shall be provided in conformance with the table below:

Total Check-out Aisles of Each Design	Minimum Number of Accessible Check-out Aisles (of Each Design)
1 - 4	1
5 - 8	2
9 - 15	3
over 15	3, plus 20% of additional aisles

EXCEPTION: In new construction, where the selling space is under 5000 square feet, only one check-out aisle is required to be accessible.

EXCEPTION: In alterations, at least one check-out aisle shall be accessible in facilities under 5000 square feet of selling space. In facilities of 5000 or more square feet of selling space, at least one of each design of check-out aisle shall be made accessible when altered until the number of accessible check-out aisles of each design equals the number required in new construction.

Examples of check-out aisles of different "design" include those which are specifically designed to serve different functions. Different "design" includes but is not limited to the following features - length of belt or no belt; or permanent signage designating the aisle as an express lane.

(2) Clear aisle width for accessible check-out aisles shall comply with 4.2.1 and maximum adjoining counter height shall not exceed 38 in (965 mm) above the finish floor. The top of the lip shall not exceed 40 in (1015 mm) above the finish floor.

(3) Signage identifying accessible check-out aisles shall comply with 4.30.7 and shall be mounted above the check-out aisle in the same location where the check-out number or type of check-out is displayed.

**7.4 Security Bollards.** Any device used to prevent the removal of shopping carts from store premises shall not prevent access or egress to people in wheelchairs. An alternate entry that is equally convenient to that provided for the ambulatory population is acceptable.

**8. LIBRARIES.**

**8.1 General.** In addition to the requirements of section 4, the design of all public areas of a library shall comply with 8, including reading and study areas, stacks, reference rooms, reserve areas, and special facilities or collections.

**8.2 Reading and Study Areas.** At least 5 percent or a minimum of one of each element of fixed seating, tables, or study carrels shall comply with 4.2 and 4.32. Clearances between fixed accessible tables and between study carrels shall comply with 4.3.

**8.3 Check-Out Areas.** At least one lane at each check-out area shall comply with 7.2(1). Any traffic control or book security gates or turnstiles shall comply with 4.13.

**8.4 Card Catalogs and Magazine Displays.** Minimum clear aisle space at card catalogs and magazine displays shall comply with Fig. 55. Maximum reach height shall comply with 4.2, with a height of 48 in (1220 mm) preferred irrespective of approach allowed.

**8.5 Stacks.** Minimum clear aisle width between stacks shall comply with 4.3, with a minimum clear aisle width of 42 in (1065 mm) preferred where possible. Shelf height in stack areas is unrestricted (see Fig. 56).

9.0 Accessible Transient Lodging

**9. ACCESSIBLE TRANSIENT LODGING.**

(1) Except as specified in the special technical provisions of this section, accessible transient lodging shall comply with the applicable requirements of section 4. Transient lodging includes facilities or portions thereof used for sleeping accommodations when not classed as a medical care facility.

**9.1 Hotels, Motels, Inns, Boarding Houses, Dormitories, Resorts and Other Similar Places of Transient Lodging.**

**9.1.1 General.** All public use and common use areas are required to be designed and constructed to comply with section 4 (Accessible Elements and Spaces: Scope and Technical Requirements).

EXCEPTION: Sections 9.1 through 9.4 do not apply to an establishment located within a building that contains not more than five rooms for rent or hire and that is actually occupied by the proprietor of such establishment as the residence of such proprietor.

**9.1.2 Accessible Units, Sleeping Rooms, and Suites.** Accessible sleeping rooms or suites that comply with the requirements of 9.2 (Requirements for Accessible Units, Sleeping Rooms, and Suites) shall be provided in conformance with the table below. In addition, in hotels, of 50 or more sleeping rooms or suites, additional accessible sleeping rooms or suites that include a roll-in shower shall also be provided in conformance with the table below. Such accommodations shall comply with the requirements of 9.2, 4.21, and Figure 57(a) or (b).

Fig. 55  
Card Catalog

Fig. 56  
Stacks

**9.1.3 Sleeping Accommodations for Persons with Hearing Impairments**

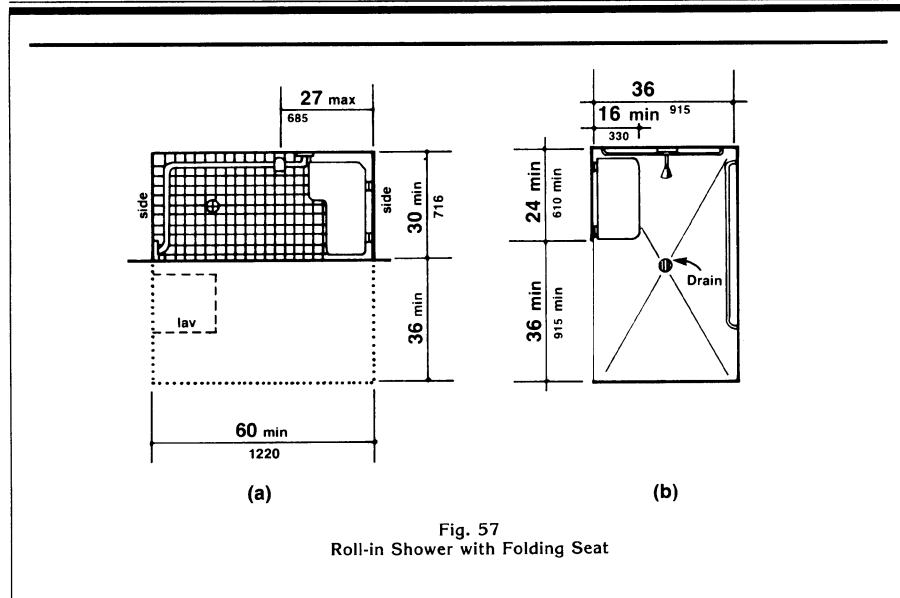

Fig. 57  
Roll-in Shower with Folding Seat

Number of Rooms	Accessible Rooms	Rooms with Roll-in Showers
1 to 25	1	
26 to 50	2	
51 to 75	3	1
76 to 100	4	1
101 to 150	5	2
151 to 200	6	2
201 to 300	7	3
301 to 400	8	4
401 to 500	9	4 plus one for each additional 100 over 400
501 to 1000	2% of total	
1001 and over	20 plus 1 for each 100 over 1000	

**9.1.3 Sleeping Accommodations for Persons with Hearing Impairments.**

In addition to those accessible sleeping rooms and suites required by 9.1.2, sleeping rooms

and suites that comply with 9.3 (Visual Alarms, Notification Devices, and Telephones) shall be provided in conformance with the following table:

Number of Elements	Accessible Elements
1 to 25	1
26 to 50	2
51 to 75	3
76 to 100	4
101 to 150	5
151 to 200	6
201 to 300	7
301 to 400	8
401 to 500	9
501 to 1000	2% of total
1001 and over	20 plus 1 for each 100 over 1000



**9.2 Requirements for Accessible Units, Sleeping Rooms and Suites**

<p><b>9.1.4 Classes of Sleeping Accommodations.</b></p> <p>(1) In order to provide persons with disabilities a range of options equivalent to those available to other persons served by the facility, sleeping rooms and suites required to be accessible by 9.1.2 shall be dispersed among the various classes of sleeping accommodations available to patrons of the place of transient lodging. Factors to be considered include room size, cost, amenities provided, and the number of beds provided.</p> <p>(2) Equivalent Facilitation. For purposes of this section, it shall be deemed equivalent facilitation if the operator of a facility elects to limit construction of accessible rooms to those intended for multiple occupancy, provided that such rooms are made available at the cost of a single-occupancy room to an individual with disabilities who requests a single-occupancy room.</p> <p><b>9.1.5. Alterations to Accessible Units, Sleeping Rooms, and Suites.</b> When sleeping rooms are being altered in an existing facility, or portion thereof, subject to the requirements of this section, at least one sleeping room or suite that complies with the requirements of 9.2 (Requirements for Accessible Units, Sleeping Rooms, and Suites) shall be provided for each 25 sleeping rooms, or fraction thereof, of rooms being altered until the number of such rooms provided equals the number required to be accessible with 9.1.2. In addition, at least one sleeping room or suite that complies with the requirements of 9.3 (Visual Alarms, Notification Devices, and Telephones) shall be provided for each 25 sleeping rooms, or fraction thereof, of rooms being altered until the number of such rooms equals the number required to be accessible by 9.1.3.</p> <p><b>9.2 Requirements for Accessible Units, Sleeping Rooms and Suites.</b></p> <p><b>9.2.1 General.</b> Units, sleeping rooms, and suites required to be accessible by 9.1 shall comply with 9.2.</p> <p><b>9.2.2 Minimum Requirements.</b> An accessible unit, sleeping room or suite shall be on an</p>	<p>accessible route complying with 4.3 and have the following accessible elements and spaces.</p> <p>(1) Accessible sleeping rooms shall have a 36 in (915 mm) clear width maneuvering space located along both sides of a bed, except that where two beds are provided, this requirement can be met by providing a 36 in (915 mm) wide maneuvering space located between the two beds.</p> <p>(2) An accessible route complying with 4.3 shall connect all accessible spaces and elements, including telephones, within the unit, sleeping room, or suite. This is not intended to require an elevator in multi-story units as long as the spaces identified in 9.2.2(6) and (7) are on accessible levels and the accessible sleeping area is suitable for dual occupancy.</p> <p>(3) Doors and doorways designed to allow passage into and within all sleeping rooms, suites or other covered units shall comply with 4.13.</p> <p>(4) If fixed or built-in storage facilities such as cabinets, shelves, closets, and drawers are provided in accessible spaces, at least one of each type provided shall contain storage space complying with 4.25. Additional storage may be provided outside of the dimensions required by 4.25.</p> <p>(5) All controls in accessible units, sleeping rooms, and suites shall comply with 4.27.</p> <p>(6) Where provided as part of an accessible unit, sleeping room, or suite, the following spaces shall be accessible and shall be on an accessible route:</p> <ul style="list-style-type: none"> <li>(a) the living area.</li> <li>(b) the dining area.</li> <li>(c) at least one sleeping area.</li> <li>(d) patios, terraces, or balconies.</li> </ul> <p>EXCEPTION: The requirements of 4.13.8 and 4.3.8 do not apply where it is necessary to utilize a higher door threshold or a change in level to protect the integrity of the unit from wind/water damage. Where this exception results in patios, terraces or balconies that are not at an accessible level, equivalent facilitation</p>
---	---

**9.3 Visual Alarms, Notification Devices and Telephones**

shall be provided. (E.g., equivalent facilitation at a hotel patio or balcony might consist of providing raised decking or a ramp to provide accessibility.)

(e) at least one full bathroom (i.e., one with a water closet, a lavatory, and a bathtub or shower).

(f) if only half baths are provided, at least one half bath.

(g) carports, garages or parking spaces.

(7) Kitchens, Kitchenettes, or Wet Bars. When provided as accessory to a sleeping room or suite, kitchens, kitchenettes, wet bars, or similar amenities shall be accessible. Clear floor space for a front or parallel approach to cabinets, counters, sinks, and appliances shall be provided to comply with 4.2.4. Countertops and sinks shall be mounted at a maximum height of 34 in (865 mm) above the floor. At least fifty percent of shelf space in cabinets or refrigerator/freezers shall be within the reach ranges of 4.2.5 or 4.2.6 and space shall be designed to allow for the operation of cabinet and/or appliance doors so that all cabinets and appliances are accessible and usable. Controls and operating mechanisms shall comply with 4.27.

(8) Sleeping room accommodations for persons with hearing impairments required by 9.1 and complying with 9.3 shall be provided in the accessible sleeping room or suite.

**9.3 Visual Alarms, Notification Devices and Telephones.**

**9.3.1 General.** In sleeping rooms required to comply with this section, auxiliary visual alarms shall be provided and shall comply with 4.28.4. Visual notification devices shall also be provided in units, sleeping rooms and suites to alert room occupants of incoming telephone calls and a door knock or bell. Notification devices shall not be connected to auxiliary visual alarm signal appliances. Permanently installed telephones shall have volume controls complying with 4.31.5; an accessible electrical outlet within 4 ft (1220 mm) of a telephone connection shall be provided to facilitate the use of a text telephone.

**9.3.2 Equivalent Facilitation.** For purposes of this section, equivalent facilitation shall include the installation of electrical outlets (including outlets connected to a facility's central alarm system) and telephone wiring in sleeping rooms and suites to enable persons with hearing impairments to utilize portable visual alarms and communication devices provided by the operator of the facility.

**9.4 Other Sleeping Rooms and Suites.** Doors and doorways designed to allow passage into and within all sleeping units or other covered units shall comply with 4.13.5.

**9.5 Transient Lodging in Homeless Shelters, Halfway Houses, Transient Group Homes, and Other Social Service Establishments.**

**9.5.1 New Construction.** In new construction all public use and common use areas are required to be designed and constructed to comply with section 4. At least one of each type of amenity (such as washers, dryers and similar equipment installed for the use of occupants) in each common area shall be accessible and shall be located on an accessible route to any accessible unit or sleeping accommodation.

EXCEPTION: Where elevators are not provided as allowed in 4.1.3(5), accessible amenities are not required on inaccessible floors as long as one of each type is provided in common areas on accessible floors.

**9.5.2 Alterations.**

(1) Social service establishments which are not homeless shelters:

(a) The provisions of 9.5.3 and 9.1.5 shall apply to sleeping rooms and beds.

(b) Alteration of other areas shall be consistent with the new construction provisions of 9.5.1.

(2) Homeless shelters. If the following elements are altered, the following requirements apply:

10.0 Transportation Facilities

<p>(a) at least one public entrance shall allow a person with mobility impairments to approach, enter and exit including a minimum clear door width of 32 in (815 mm).</p> <p>(b) sleeping space for homeless persons as provided in the scoping provisions of 9.1.2 shall include doors to the sleeping area with a minimum clear width of 32 in (815 mm) and maneuvering space around the beds for persons with mobility impairments complying with 9.2.2(1).</p> <p>(c) at least one toilet room for each gender or one unisex toilet room shall have a minimum clear door width of 32 in (815 mm), minimum turning space complying with 4.2.3, one water closet complying with 4.16, one lavatory complying with 4.19 and the door shall have a privacy latch; and, if provided, at least one tub or shower shall comply with 4.20 or 4.21, respectively.</p> <p>(d) at least one common area which a person with mobility impairments can approach, enter and exit including a minimum clear door width of 32 in (815 mm).</p> <p>(e) at least one route connecting elements (a), (b), (c) and (d) which a person with mobility impairments can use including minimum clear width of 36 in (915 mm), passing space complying with 4.3.4, turning space complying with 4.2.3 and changes in levels complying with 4.3.8.</p> <p>(f) homeless shelters can comply with the provisions of (a)-(e) by providing the above elements on one accessible floor.</p> <p><b>9.5.3 Accessible Sleeping Accommodations in New Construction.</b> Accessible sleeping rooms shall be provided in conformance with the table in 9.1.2 and shall comply with 9.2 Accessible Units, Sleeping Rooms and Suites (where the items are provided). Additional sleeping rooms that comply with 9.3 Sleeping Accommodations for Persons with Hearing Impairments shall be provided in conformance with the table provided in 9.1.3.</p> <p>In facilities with multi-bed rooms or spaces, a percentage of the beds equal to the table provided in 9.1.2 shall comply with 9.2.2(1).</p>	<table border="1" style="width: 100%; border-collapse: collapse;"> <tr> <td style="width: 5%; text-align: center; vertical-align: middle;"><b>10.</b></td> <td style="padding: 5px;"><b>TRANSPORTATION FACILITIES.</b></td> </tr> </table> <p><b>10.1 General.</b> Every station, bus stop, bus stop pad, terminal, building or other transportation facility, shall comply with the applicable provisions of section 4, the special application sections, and the applicable provisions of this section.</p> <p><b>10.2 Bus Stops and Terminals.</b></p> <p><b>10.2.1 New Construction.</b></p> <p>(1) Where new bus stop pads are constructed at bus stops, bays or other areas where a lift or ramp is to be deployed, they shall have a firm, stable surface; a minimum clear length of 96 inches (measured from the curb or vehicle roadway edge) and a minimum clear width of 60 inches (measured parallel to the vehicle roadway) to the maximum extent allowed by legal or site constraints; and shall be connected to streets, sidewalks or pedestrian paths by an accessible route complying with 4.3 and 4.4. The slope of the pad parallel to the roadway shall, to the extent practicable, be the same as the roadway. For water drainage, a maximum slope of 1:50 (2%) perpendicular to the roadway is allowed.</p> <p>(2) Where provided, new or replaced bus shelters shall be installed or positioned so as to permit a wheelchair or mobility aid user to enter from the public way and to reach a location, having a minimum clear floor area of 30 inches by 48 inches, entirely within the perimeter of the shelter. Such shelters shall be connected by an accessible route to the boarding area provided under paragraph (1) of this section.</p> <p>(3) Where provided, all new bus route identification signs shall comply with 4.30.5. In addition, to the maximum extent practicable, all new bus route identification signs shall comply with 4.30.2 and 4.30.3. Signs</p>	<b>10.</b>	<b>TRANSPORTATION FACILITIES.</b>
<b>10.</b>	<b>TRANSPORTATION FACILITIES.</b>		

**10.3 Fixed Facilities and Stations**

that are sized to the maximum dimensions permitted under legitimate local, state or federal regulations or ordinances shall be considered in compliance with 4.30.2 and 4.30.3 for purposes of this section.

EXCEPTION: Bus schedules, timetables, or maps that are posted at the bus stop or bus bay are not required to comply with this provision.

**10.2.2 Bus Stop Siting and Alterations.**

(1) Bus stop sites shall be chosen such that, to the maximum extent practicable, the areas where lifts or ramps are to be deployed comply with section 10.2.1(1) and (2).

(2) When new bus route identification signs are installed or old signs are replaced, they shall comply with the requirements of 10.2.1(3).

**10.3 Fixed Facilities and Stations.**

**10.3.1 New Construction.** New stations in rapid rail, light rail, commuter rail, intercity bus, intercity rail, high speed rail, and other fixed guideway systems (e.g., automated guideway transit, monorails, etc.) shall comply with the following provisions, as applicable:

(1) Elements such as ramps, elevators or other circulation devices, fare vending or other ticketing areas, and fare collection areas shall be placed to minimize the distance which wheelchair users and other persons who cannot negotiate steps may have to travel compared to the general public. The circulation path, including an accessible entrance and an accessible route, for persons with disabilities shall, to the maximum extent practicable, coincide with the circulation path for the general public. Where the circulation path is different, signage complying with 4.30.1, 4.30.2, 4.30.3, 4.30.5, and 4.30.7(1) shall be provided to indicate direction to and identify the accessible entrance and accessible route.

(2) In lieu of compliance with 4.1.3(8), at least one entrance to each station shall comply with 4.14, Entrances. If different entrances to a station serve different transportation fixed routes or groups of fixed routes, at least one entrance serving each group or route shall

comply with 4.14, Entrances. All accessible entrances shall, to the maximum extent practicable, coincide with those used by the majority of the general public.

(3) Direct connections to commercial, retail, or residential facilities shall have an accessible route complying with 4.3 from the point of connection to boarding platforms and all transportation system elements used by the public. Any elements provided to facilitate future direct connections shall be on an accessible route connecting boarding platforms and all transportation system elements used by the public.

(4) Where signs are provided at entrances to stations identifying the station or the entrance, or both, at least one sign at each entrance shall comply with 4.30.4 and 4.30.6. Such signs shall be placed in uniform locations at entrances within the transit system to the maximum extent practicable.

EXCEPTION: Where the station has no defined entrance, but signage is provided, then the accessible signage shall be placed in a central location.

(5) Stations covered by this section shall have identification signs complying with 4.30.1, 4.30.2, 4.30.3, and 4.30.5. Signs shall be placed at frequent intervals and shall be clearly visible from within the vehicle on both sides when not obstructed by another train. When station identification signs are placed close to vehicle windows (i.e., on the side opposite from boarding) each shall have the top of the highest letter or symbol below the top of the vehicle window and the bottom of the lowest letter or symbol above the horizontal mid-line of the vehicle window.

(6) Lists of stations, routes, or destinations served by the station and located on boarding areas, platforms, or mezzanines shall comply with 4.30.1, 4.30.2, 4.30.3, and 4.30.5. A minimum of one sign identifying the specific station and complying with 4.30.4 and 4.30.6 shall be provided on each platform or boarding area. All signs referenced in this paragraph shall, to the maximum extent practicable, be placed in uniform locations within the transit system.

10.3 Fixed Facilities and Stations

<p>(7)* Automatic fare vending, collection and adjustment (e.g., add-fare) systems shall comply with 4.34.2, 4.34.3, 4.34.4, and 4.34.5. At each accessible entrance such devices shall be located on an accessible route. If self-service fare collection devices are provided for the use of the general public, at least one accessible device for entering, and at least one for exiting, unless one device serves both functions, shall be provided at each accessible point of entry or exit. Accessible fare collection devices shall have a minimum clear opening width of 32 inches; shall permit passage of a wheelchair; and, where provided, coin or card slots and controls necessary for operation shall comply with 4.27. Gates which must be pushed open by wheelchair or mobility aid users shall have a smooth continuous surface extending from 2 inches above the floor to 27 inches above the floor and shall comply with 4.13. Where the circulation path does not coincide with that used by the general public, accessible fare collection systems shall be located at or adjacent to the accessible point of entry or exit.</p> <p>(8) Platform edges bordering a drop-off and not protected by platform screens or guard rails shall have a detectable warning. Such detectable warnings shall comply with 4.29.2 and shall be 24 inches wide running the full length of the platform drop-off.</p> <p>(9) In stations covered by this section, rail-to-platform height in new stations shall be coordinated with the floor height of new vehicles so that the vertical difference, measured when the vehicle is at rest, is within plus or minus 5/8 inch under normal passenger load conditions. For rapid rail, light rail, commuter rail, high speed rail, and intercity rail systems in new stations, the horizontal gap, measured when the new vehicle is at rest, shall be no greater than 3 inches. For slow moving automated guideway "people mover" transit systems, the horizontal gap in new stations shall be no greater than 1 inch.</p> <p>EXCEPTION 1: Existing vehicles operating in new stations may have a vertical difference with respect to the new platform within plus or minus 1-1/2 inches.</p> <p>EXCEPTION 2: In light rail, commuter rail and intercity rail systems where it is not operationally or structurally feasible to meet the horizontal gap or vertical difference</p>	<p>requirements, mini-high platforms, car-borne or platform-mounted lifts, ramps or bridge plates, or similar manually deployed devices, meeting the applicable requirements of 36 CFR part 1192, or 49 CFR part 38 shall suffice.</p> <p>(10) Stations shall not be designed or constructed so as to require persons with disabilities to board or alight from a vehicle at a location other than one used by the general public.</p> <p>(11) Illumination levels in the areas where signage is located shall be uniform and shall minimize glare on signs. Lighting along circulation routes shall be of a type and configuration to provide uniform illumination.</p> <p>(12) Text Telephones: The following shall be provided in accordance with 4.31.9:</p> <p>(a) If an interior public pay telephone is provided in a transit facility (as defined by the Department of Transportation) at least one interior public text telephone shall be provided in the station.</p> <p>(b) Where four or more public pay telephones serve a particular entrance to a rail station and at least one is in an interior location, at least one interior public text telephone shall be provided to serve that entrance. Compliance with this section constitutes compliance with section 4.1.3(17)(c).</p> <p>(13) Where it is necessary to cross tracks to reach boarding platforms, the route surface shall be level and flush with the rail top at the outer edge and between the rails, except for a maximum 2-1/2 inch gap on the inner edge of each rail to permit passage of wheel flanges. Such crossings shall comply with 4.29.5. Where gap reduction is not practicable, an above-grade or below-grade accessible route shall be provided.</p> <p>(14) Where public address systems are provided to convey information to the public in terminals, stations, or other fixed facilities, a means of conveying the same or equivalent information to persons with hearing loss or who are deaf shall be provided.</p>
--	--

**10.3.2 Existing Facilities: Key Stations.**

(15) Where clocks are provided for use by the general public, the clock face shall be uncluttered so that its elements are clearly visible. Hands, numerals, and/or digits shall contrast with the background either light-on-dark or dark-on-light. Where clocks are mounted overhead, numerals and/or digits shall comply with 4.30.3. Clocks shall be placed in uniform locations throughout the facility and system to the maximum extent practicable.

(16) Where provided in below grade stations, escalators shall have a minimum clear width of 32 inches. At the top and bottom of each escalator run, at least two contiguous treads shall be level beyond the comb plate before the risers begin to form. All escalator treads shall be marked by a strip of clearly contrasting color, 2 inches in width, placed parallel to and on the nose of each step. The strip shall be of a material that is at least as slip resistant as the remainder of the tread. The edge of the tread shall be apparent from both ascending and descending directions.

(17) Where provided, elevators shall be glazed or have transparent panels to allow an unobstructed view both in to and out of the car. Elevators shall comply with 4.10.

EXCEPTION: Elevator cars with a clear floor area in which a 60 inch diameter circle can be inscribed may be substituted for the minimum car dimensions of 4.10, Fig. 22.

(18) Where provided, ticketing areas shall permit persons with disabilities to obtain a ticket and check baggage and shall comply with 7.2.

(19) Where provided, baggage check-in and retrieval systems shall be on an accessible route complying with 4.3, and shall have space immediately adjacent complying with 4.2. If unattended security barriers are provided, at least one gate shall comply with 4.13. Gates which must be pushed open by wheelchair or mobility aid users shall have a smooth continuous surface extending from 2 inches above the floor to 27 inches above the floor.

**10.3.2 Existing Facilities: Key Stations.**

(1) Rapid, light and commuter rail key stations, as defined under criteria established by the Department of Transportation in subpart C of 49 CFR part 37 and existing intercity rail stations shall provide at least one accessible route from an accessible entrance to those areas necessary for use of the transportation system.

(2) The accessible route required by 10.3.2(1) shall include the features specified in 10.3.1(1), (4)-(9), (11)-(15), and (17)-(19).

(3) Where technical infeasibility in existing stations requires the accessible route to lead from the public way to a paid area of the transit system, an accessible fare collection system, complying with 10.3.1(7), shall be provided along such accessible route.

(4) In light rail, rapid rail and commuter rail key stations, the platform or a portion thereof and the vehicle floor shall be coordinated so that the vertical difference, measured when the vehicle is at rest, is within plus or minus 1-1/2 inches under all normal passenger load conditions, and the horizontal gap, measured when the vehicle is at rest, is no greater than 3 inches for at least one door of each vehicle or car required to be accessible by 49 CFR part 37.

EXCEPTION 1: Existing vehicles retrofitted to meet the requirements of 49 CFR 37.93 (one-car-per-train rule) shall be coordinated with the platform such that, for at least one door, the vertical difference between the vehicle floor and the platform, measured when the vehicle is at rest with 50% normal passenger capacity, is within plus or minus 2 inches and the horizontal gap is no greater than 4 inches.

EXCEPTION 2: Where it is not structurally or operationally feasible to meet the horizontal gap or vertical difference requirements, mini-high platforms, car-borne or platform mounted lifts, ramps or bridge plates, or similar manually deployed devices, meeting the applicable requirements of 36 CFR part 1192, or 49 CFR part 38, shall suffice.

10.4 Airports

<p>(5) New direct connections to commercial, retail, or residential facilities shall, to the maximum extent feasible, have an accessible route complying with 4.3 from the point of connection to boarding platforms and all transportation system elements used by the public. Any elements provided to facilitate future direct connections shall be on an accessible route connecting boarding platforms and all transportation system elements used by the public.</p> <p><b>10.3.3 Existing Facilities: Alterations.</b></p> <p>(1) For the purpose of complying with 4.1.6(2) (Alterations to an Area Containing a Primary Function), an area of primary function shall be as defined by applicable provisions of 49 CFR 37.43(c) (Department of Transportation's ADA Rule) or 28 CFR 36.403 (Department of Justice's ADA Rule).</p> <p><b>10.4 Airports.</b></p> <p><b>10.4.1 New Construction.</b></p> <p>(1) Elements such as ramps, elevators or other vertical circulation devices, ticketing areas, security checkpoints, or passenger waiting areas shall be placed to minimize the distance which wheelchair users and other persons who cannot negotiate steps may have to travel compared to the general public.</p> <p>(2) The circulation path, including an accessible entrance and an accessible route, for persons with disabilities shall, to the maximum extent practicable, coincide with the circulation path for the general public. Where the circulation path is different, directional signage complying with 4.30.1, 4.30.2, 4.30.3 and 4.30.5 shall be provided which indicates the location of the nearest accessible entrance and its accessible route.</p> <p>(3) Ticketing areas shall permit persons with disabilities to obtain a ticket and check baggage and shall comply with 7.2.</p> <p>(4) Where public pay telephones are provided, and at least one is at an interior location, a public text telephone (TTY) shall be provided in compliance with 4.31.9. Additionally, if four or more public pay telephones are located in any of the following locations, at least one public text telephone (TTY) shall also be provided in that location:</p>	<p>(a) a main terminal outside the security areas;</p> <p>(b) a concourse within the security areas; or</p> <p>(c) a baggage claim area in a terminal.</p> <p>Compliance with this section constitutes compliance with section 4.1.3(17)(c).</p> <p>(5) Baggage check-in and retrieval systems shall be on an accessible route complying with 4.3, and shall have space immediately adjacent complying with 4.2.4. If unattended security barriers are provided, at least one gate shall comply with 4.13. Gates which must be pushed open by wheelchair or mobility aid users shall have a smooth continuous surface extending from 2 in (50 mm) above the floor to 27 in (685 mm) above the floor.</p> <p>(6) Terminal information systems which broadcast information to the general public through a public address system shall provide a means to provide the same or equivalent information to persons with a hearing loss or who are deaf. Such methods may include, but are not limited to, visual paging systems using video monitors and computer technology. For persons with certain types of hearing loss such methods may include, but are not limited to, an assistive listening system complying with 4.33.7.</p> <p>(7) Where clocks are provided for use by the general public the clock face shall be uncluttered so that its elements are clearly visible. Hands, numerals, and/or digits shall contrast with their background either light-on-dark or dark-on-light. Where clocks are mounted overhead, numerals and/or digits shall comply with 4.30.3. Clocks shall be placed in uniform locations throughout the facility to the maximum extent practicable.</p> <p>(8)* Security Systems. In public facilities that are airports, at least one accessible route complying with 4.3 shall be provided through fixed security barriers at each single barrier or group of security barriers. A group is two or more security barriers immediately adjacent to each other at a single location. Where security barriers incorporate equipment such as metal detectors, fluoroscopes, or other similar devices which cannot be made accessible, an</p>
--	--

**11.0 Judicial, Legislative and Regulatory Facilities**

accessible route shall be provided adjacent to such security screening devices to facilitate an equivalent circulation path. The circulation path shall permit persons with disabilities passing through security barriers to maintain visual contact with their personal items to the same extent provided other members of the general public.

EXCEPTION: Doors, doorways, and gates designed to be operated only by security personnel shall be exempt from 4.13.9, 4.13.11, and 4.13.12.

**10.5 Boat and Ferry Docks. (Reserved).**

**11. JUDICIAL, LEGISLATIVE AND REGULATORY FACILITIES.**

**11.1 General.** In addition to the requirements in section 4 and 11.1, judicial facilities shall comply with 11.2 and legislative and regulatory facilities shall comply with 11.3.

**11.1.1 Entrances.** Where provided, at least one restricted entrance and one secured entrance to the facility shall be accessible in addition to the entrances required to be accessible by 4.1.3(8). Restricted entrances are those entrances used only by judges, public officials, facility personnel or other authorized parties on a controlled basis. Secured entrances are those entrances to judicial facilities used only by detainees and detention officers.

EXCEPTION: At secured entrances, doors and doorways operated only by security personnel shall be exempt from 4.13.9, 4.13.10, 4.13.11 and 4.13.12.

**11.1.2 Security Systems.** An accessible route complying with 4.3 shall be provided through fixed security barriers at required accessible entrances. Where security barriers incorporate equipment such as metal detectors, fluoroscopes, or other similar devices which cannot be made accessible, an accessible route shall be provided adjacent to such security screening devices to facilitate an equivalent circulation path.

**11.1.3\* Two-Way Communication Systems.** Where a two-way communication system is provided to gain admittance to a facility or to restricted areas within the facility, the system shall provide both visual and audible signals and shall comply with 4.27.

**11.2 Judicial Facilities.**

**11.2.1 Courtrooms.**

(1) Where provided, the following elements and spaces shall be on an accessible route complying with 4.3. Areas that are raised or depressed and accessed by ramps or platform lifts with entry ramps shall provide unobstructed turning space complying with 4.2.3.

EXCEPTION: Vertical access to raised judges' benches or courtroom stations need not be installed provided that the requisite areas, maneuvering spaces, and, if appropriate, electrical service are installed at the time of initial construction to allow future installation of a means of vertical access complying with 4.8, 4.10, or 4.11 without requiring substantial reconstruction of the space.

(a) Spectator, Press, and Other Areas with Fixed Seats. Where spectator, press or other areas with fixed seats are provided, each type of seating area shall comply with 4.1.3(19)(a).

(b) Jury Boxes and Witness Stands. Each jury box and witness stand shall have within its defined area clear floor space complying with 4.2.4.

EXCEPTION: In alterations, accessible wheelchair spaces are not required to be located within the defined area of raised jury boxes or witness stands and may be located outside these spaces where ramp or lift access poses a hazard by restricting or projecting into a means of egress required by the appropriate administrative authority.

(c) Judges' Benches and Courtroom Stations. Judges' benches, clerks' stations, bailiffs' stations, deputy clerks' stations, court reporters' stations and litigants' and counsel stations shall comply with 4.32.

(2)\* Permanently installed assistive listening systems complying with 4.33 shall be provided in each courtroom. The minimum number of receivers shall be four percent of the room



**11.2.2 Jury Assembly Areas and Jury Deliberation Areas**

<p>occupant load, as determined by applicable State or local codes, but not less than two receivers. An informational sign indicating the availability of an assistive listening system and complying with 4.30.1, 4.30.2, 4.30.3, 4.30.5, and 4.30.7(4) shall be posted in a prominent place.</p> <p><b>11.2.2 Jury Assembly Areas and Jury Deliberation Areas.</b> Where provided in areas used for jury assembly or deliberation, the following elements or spaces shall be on an accessible route complying with 4.3 and shall comply with the following provisions:</p> <p>(1) Refreshment Areas. Refreshment areas, kitchenettes and fixed or built-in refreshment dispensers shall comply with the technical provisions of 9.2.2(7).</p> <p>(2) Drinking Fountains. Where provided in rooms covered under 11.2.2, there shall be a drinking fountain in each room complying with 4.15.</p> <p><b>11.2.3 Courthouse Holding Facilities.</b></p> <p>(1) Holding Cells - Minimum Number. Where provided, facilities for detainees, including central holding cells and court-floor holding cells, shall comply with the following:</p> <p>(a) Central Holding Cells. Where separate central holding cells are provided for adult male, juvenile male, adult female, or juvenile female, one of each type shall comply with 11.2.3(2). Where central-holding cells are provided, which are not separated by age or sex, at least one cell complying with 11.2.3(2) shall be provided.</p> <p>(b) Court-Floor Holding Cells. Where separate court-floor holding cells are provided for adult male, juvenile male, adult female, or juvenile female, each courtroom shall be served by one cell of each type complying with 11.2.3(2). Where court-floor holding cells are provided, which are not separated by age or sex, courtrooms shall be served by at least one cell complying with 11.2.3(2). Cells may serve more than one courtroom.</p> <p>(2) Requirements for Accessible Cells. Accessible cells shall be on an accessible route complying with 4.3. Where provided, the following elements or spaces serving accessible cells shall be accessible and on an accessible route:</p>	<p>(a) Doors and Doorways. All doors and doorways to accessible spaces and on an accessible route shall comply with 4.13.</p> <p>EXCEPTION: Doors and doorways operated only by security personnel shall be exempt from 4.13.9, 4.13.10, 4.13.11 and 4.13.12.</p> <p>(b)* Toilet and Bathing Facilities. Toilet facilities shall comply with 4.22 and bathing facilities shall comply with 4.23. Privacy screens shall not intrude on the clear floor space required for fixtures or the accessible route.</p> <p>(c)* Beds. Beds shall have maneuvering space at least 36 in (915 mm) wide along one side. Where more than one bed is provided in a cell, the maneuvering space provided at adjacent beds may overlap.</p> <p>(d) Drinking Fountains and Water Coolers. Drinking fountains shall be accessible to individuals who use wheelchairs in accordance with 4.15 and shall be accessible to those who have difficulty bending or stooping. This can be accomplished by the use of a "hi-lo" fountain; by providing one fountain accessible to those who use wheelchairs and one fountain at a standard height convenient for those who have difficulty bending; by providing a fountain accessible under 4.15 and a water cooler; or by other such means as would achieve the required accessibility for each group.</p> <p>(e) Fixed or Built-in Seating and Tables. Fixed or built-in seating, tables or counters shall comply with 4.32.</p> <p>(f) Fixed Benches. Fixed benches shall be mounted at 17 in to 19 in (430 mm to 485 mm) above the finish floor and provide back support (e.g., attachment to wall). The structural strength of the bench attachments shall comply with 4.26.3.</p> <p>(3)* Visiting Areas. The following elements, where provided, shall be located on an accessible route complying with 4.3 and shall comply with the following provisions:</p> <p>(a) Cubicles and Counters. Five percent, but not less than one, of fixed cubicles shall comply with 4.32 on both the visitor and detainee sides. Where counters are provided, a portion at least 36 in (915 mm) in length shall comply with 4.32 on both the visitor and detainee sides.</p>
--	---

**12.0 Detention and Correctional Facilities**

(b) Partitions. Solid partitions or security glazing that separate visitors from detainees shall comply with 7.2(3).

**11.3\* Legislative and Regulatory Facilities.** Assembly areas designated for public use, including public meeting rooms, hearing rooms, and chambers shall comply with 11.3.

**11.3.1** Where provided, the following elements and spaces shall be on an accessible route complying with 4.3. Areas that are raised or depressed and accessed by ramps or platform lifts with entry ramps shall provide unobstructed turning space complying with 4.2.3.

(1) Raised Speakers' Platforms. Where raised speakers' platforms are provided, at least one of each type shall be accessible.

(2)\* Spectator, Press, and Other Areas with Fixed Seats. Where spectator, press or other areas with fixed seats are provided, each type of seating area shall comply with 4.1.3(19)(a).

**11.3.2\*** Each assembly area provided with a permanently installed audio-amplification system shall have a permanently installed assistive listening system. The minimum number of receivers shall be four percent of the room occupant load, as determined by applicable State or local codes, but not less than two receivers. An informational sign indicating the availability of an assistive listening system and complying with 4.30.1, 4.30.2, 4.30.3, 4.30.5, and 4.30.7(4) shall be posted in a prominent place.

**12. DETENTION AND CORRECTIONAL FACILITIES.**

**12.1\* General.** This section applies to jails, holding cells in police stations, prisons, juvenile detention centers, reformatories, and other institutional occupancies where occupants are under some degree of restraint or restriction for security reasons. Except as specified in this section, detention and correctional facilities shall comply with the applicable requirements of section 4. All common use areas

serving accessible cells or rooms and all public use areas are required to be designed and constructed to comply with section 4.

EXCEPTIONS: Requirements for areas of rescue assistance in 4.1.3(9), 4.3.10, and 4.3.11 do not apply. Compliance with requirements for elevators in 4.1.3(5) and stairs 4.1.3(4) is not required in multi-story housing facilities where accessible cells or rooms, all common use areas serving them, and all public use areas are on an accessible route. Compliance with 4.1.3(16) is not required in areas other than public use areas.

**12.2 Entrances and Security Systems.**

**12.2.1\* Entrances.** Entrances used by the public, including those that are secured, shall be accessible as required by 4.1.3(8).

EXCEPTION: Compliance with 4.13.9, 4.13.10, 4.13.11 and 4.13.12 is not required at entrances, doors, or doorways that are operated only by security personnel or where security requirements prohibit full compliance with these provisions.

**12.2.2 Security Systems.** Where security systems are provided at public or other entrances required to be accessible by 12.2.1 or 12.2.2, an accessible route complying with 4.3 shall be provided through fixed security barriers. Where security barriers incorporate equipment such as metal detectors, fluoroscopes, or other similar devices which cannot be made accessible, an accessible route shall be provided adjacent to such security screening devices to facilitate an equivalent circulation path.

**12.3\* Visiting Areas.** In non-contact visiting areas where inmates or detainees are separated from visitors, the following elements, where provided, shall be accessible and located on an accessible route complying with 4.3:

(1) Cubicles and Counters. Five percent, but not less than one, of fixed cubicles shall comply with 4.32 on both the visitor and detainee or inmate sides. Where counters are provided, a portion at least 36 in (915 mm) in length shall comply with 4.32 on both the visitor and detainee or inmate sides.

**12.4 Holding and Housing Cells or Rooms: Minimum Number**

<p>EXCEPTION: At non-contact visiting areas not serving accessible cells or rooms, the requirements of 12.3(1) do not apply to the inmate or detainee side of cubicles or counters.</p> <p>(2) Partitions. Solid partitions or security glazing separating visitors from inmates or detainees shall comply with 7.2(3).</p> <p><b>12.4 Holding and Housing Cells or Rooms: Minimum Number.</b></p> <p><b>12.4.1* Holding Cells and General Housing Cells or Rooms.</b> At least two percent, but not less than one, of the total number of housing or holding cells or rooms provided in a facility shall comply with 12.5</p> <p><b>12.4.2* Special Holding and Housing Cells or Rooms.</b> In addition to the requirements of 12.4.1, where special holding or housing cells or rooms are provided, at least one serving each purpose shall comply with 12.5. An accessible special holding or housing cell or room may serve more than one purpose. Cells or rooms subject to this requirement include, but are not limited to, those used for purposes of orientation, protective custody, administrative or disciplinary detention or segregation, detoxification, and medical isolation.</p> <p>EXCEPTION: Cells or rooms specially designed without protrusions and to be used solely for purposes of suicide prevention are exempt from the requirement for grab bars at water closets in 4.16.4.</p> <p><b>12.4.3* Accessible Cells or Rooms for Persons with Hearing Impairments.</b> In addition to the requirements of 12.4.1, two percent, but not less than one, of general housing or holding cells or rooms equipped with audible emergency warning systems or permanently installed telephones within the cell or room shall comply with the applicable requirements of 12.6.</p> <p><b>12.4.4 Medical Care Facilities.</b> Medical care facilities providing physical or medical treatment or care shall comply with the applicable requirements of section 6.1, 6.3 and 6.4, if persons may need assistance in emergencies and the period of stay may exceed 24 hours. Patient bedrooms or cells required to be acces-</p>	<p>sible under 6.1 and 6.3 shall be provided in addition to any medical isolation cells required to be accessible under 12.4.2.</p> <p><b>12.4.5 Alterations to Cells or Rooms.</b> (Reserved.)</p> <p><b>12.5 Requirements for Accessible Cells or Rooms.</b></p> <p><b>12.5.1 General.</b> Cells or rooms required to be accessible by 12.4 shall comply with 12.5.</p> <p><b>12.5.2* Minimum Requirements.</b> Accessible cells or rooms shall be on an accessible route complying with 4.3. Where provided to serve accessible housing or holding cells or rooms, the following elements or spaces shall be accessible and connected by an accessible route.</p> <p>(1) Doors and Doorways. All doors and doorways on an accessible route shall comply with 4.13.</p> <p>EXCEPTION: Compliance with 4.13.9, 4.13.10, 4.13.11 and 4.13.12 is not required at entrances, doors, or doorways that are operated only by security personnel or where security requirements prohibit full compliance with these provisions.</p> <p>(2)* Toilet and Bathing Facilities. At least one toilet facility shall comply with 4.22 and one bathing facility shall comply with 4.23. Privacy screens shall not intrude on the clear floor space required for fixtures and the accessible route.</p> <p>(3)* Beds. Beds shall have maneuvering space at least 36 in (915 mm) wide along one side. Where more than one bed is provided in a room or cell, the maneuvering space provided at adjacent beds may overlap.</p> <p>(4) Drinking Fountains and Water Coolers. At least one drinking fountain shall comply with 4.15.</p> <p>(5) Fixed or Built-in Seating or Tables. Fixed or built-in seating, tables and counters shall comply with 4.32.</p> <p>(6) Fixed Benches. At least one fixed bench shall be mounted at 17 in to 19 in (430 mm to 485 mm) above the finish floor and provide</p>
---	--

**12.6 Visible Alarms and Telephones**

back support (e.g., attachment to wall). The structural strength of the bench attachments shall comply with 4.26.3.

(7) Storage. Fixed or built-in storage facilities, such as cabinets, shelves, closets, and drawers, shall contain storage space complying with 4.25.

(8) Controls. All controls intended for operation by inmates shall comply with 4.27.

(9) Accommodations for persons with hearing impairments required by 12.4.3 and complying with 12.6 shall be provided in accessible cells or rooms.

**12.6 Visible Alarms and Telephones.** Where audible emergency warning systems are provided to serve the occupants of holding or housing cells or rooms, visual alarms complying with 4.28.4 shall be provided. Where permanently installed telephones are provided within holding or housing cells or rooms, they shall have volume controls complying with 4.31.5.

EXCEPTION: Visual alarms are not required where inmates or detainees are not allowed independent means of egress.

<b>13.</b>	<b>RESIDENTIAL HOUSING. (Reserved).</b>
<b>14.</b>	<b>PUBLIC RIGHTS-OF-WAY. (Reserved).</b>
<b>15.</b>	<b>RECREATION FACILITIES.</b>

Newly designed or newly constructed and altered recreation facilities shall comply with the applicable requirements of section 4 and the special application sections, except as modified or otherwise provided in this section.

**15.1\* Amusement Rides.**

**15.1.1 General.** Newly designed or newly constructed and altered amusement rides shall comply with 15.1.

EXCEPTION 1\*: Mobile or portable amusement rides shall not be required to comply with 15.1.

EXCEPTION 2\*: Amusement rides which are controlled or operated by the rider shall be required to comply only with 15.1.4 and 15.1.5.

EXCEPTION 3\*: Amusement rides designed primarily for children, where children are assisted on and off the ride by an adult, shall be required to comply only with 15.1.4 and 15.1.5.

EXCEPTION 4: Amusement rides without amusement ride seats shall be required to comply only with 15.1.4 and 15.1.5.

**15.1.2\* Alterations to Amusement Rides.** A modification to an existing amusement ride is an alteration subject to 15.1 if one or more of the following conditions apply:

(1) The amusement ride's structural or operational characteristics are changed to the extent that the ride's performance differs from that specified by the manufacturer or the original design criteria; or

(2) The load and unload area of the amusement ride is newly designed and constructed.

**15.1.3 Number Required.** Each amusement ride shall provide at least one wheelchair space complying with 15.1.7, or at least one amusement ride seat designed for transfer complying with 15.1.8, or at least one transfer device complying with 15.1.9.

**15.1.4\* Accessible Route.** When in the load and unload position, amusement rides required to comply with 15.1 shall be served by an accessible route complying with 4.3. Any part of an accessible route serving amusement rides with a slope greater than 1:20 shall be considered a ramp and shall comply with 4.8.

15.1 Amusement Rides

<p>EXCEPTION 1: The maximum slope specified in 4.8.2 shall not apply in the load and unload areas or on the amusement ride where compliance is structurally or operationally infeasible, provided that the slope of the ramp shall not exceed 1:8.</p> <p>EXCEPTION 2: Handrails shall not be required in the load and unload areas or on the amusement ride where compliance is structurally or operationally infeasible.</p> <p>EXCEPTION 3: Limited-use/limited-application elevators and platform lifts complying with 4.1.1 shall be permitted to be part of an accessible route serving the load and unload area.</p> <p><b>15.1.5 Load and Unload Areas.</b> Load and unload areas serving amusement rides required to comply with 15.1 shall provide a maneuvering space complying with 4.2.3. The maneuvering space shall have a slope not steeper than 1:48.</p> <p><b>15.1.6 Signage.</b> Signage shall be provided at the entrance of the queue or waiting line for each amusement ride to identify the type of access provided. Where an accessible unload area also serves as the accessible load area, signage shall be provided at the entrance to the queue or waiting line indicating the location of the accessible load and unload area.</p> <p><b>15.1.7 Amusement Rides with Wheelchair Spaces.</b> Amusement rides with wheelchair spaces shall comply with 15.1.7.</p> <p><b>15.1.7.1 Floor or Ground Surface.</b> The floor or ground surface of wheelchair spaces shall comply with 15.1.7.1.</p> <p><b>15.1.7.1.1 Slope.</b> The floor or ground surface of wheelchair spaces shall have a slope not steeper than 1:48 when in the load and unload position and shall be stable and firm.</p> <p><b>15.1.7.1.2* Gaps.</b> Floors of amusement rides with wheelchair spaces and floors of load and unload areas shall be coordinated so that, when the amusement rides are at rest in the load and unload position, the vertical difference between the floors shall be within plus or minus 5/8 inches</p>	<p>(16 mm) and the horizontal gap shall be no greater than 3 inches (75 mm) under normal passenger load conditions.</p> <p>EXCEPTION: Where compliance is not operationally or structurally feasible, ramps, bridge plates, or similar devices complying with the applicable requirements of 36 CFR 1192.83(c) shall be provided.</p> <p><b>15.1.7.2 Clearances.</b> Clearances for wheelchair spaces shall comply with 15.1.7.2.</p> <p>EXCEPTION 1: Where provided, securement devices shall be permitted to overlap required clearances.</p> <p>EXCEPTION 2: Wheelchair spaces shall be permitted to be mechanically or manually repositioned.</p> <p>EXCEPTION 3*: Wheelchair spaces shall not be required to comply with 4.4.2.</p> <p><b>15.1.7.2.1 Width and Length.</b> Wheelchair spaces shall provide a clear width of 30 inches (760 mm) minimum and a clear length of 48 inches (1220 mm) minimum measured to 9 inches (230 mm) minimum above the floor surface.</p> <p><b>15.1.7.2.2* Wheelchair Spaces - Side Entry.</b> Where the wheelchair space can be entered only from the side, the ride shall be designed to permit sufficient maneuvering space for individuals using a wheelchair or mobility device to enter and exit the ride.</p> <p><b>15.1.7.2.3 Protrusions in Wheelchair Spaces.</b> Objects are permitted to protrude a distance of 6 inches (150 mm) maximum along the front of the wheelchair space where located 9 inches (230 mm) minimum and 27 inches (685 mm) maximum above the floor or ground surface of the wheelchair space. Objects are permitted to protrude a distance of 25 inches (635 mm) maximum along the front of the wheelchair space, where located more than 27 inches (685 mm) above the floor or ground surface of the wheelchair space (see Fig. 58).</p>
---	---

15.1 Amusement Rides

	<p><b>15.1.8* Amusement Ride Seats Designed for Transfer.</b> Amusement ride seats designed for transfer shall comply with 15.1.8 when positioned for loading and unloading.</p> <p><b>15.1.8.1 Clear Floor or Ground Space.</b> Clear floor or ground space complying with 4.2.4 shall be provided in the load and unload area adjacent to the amusement ride seats designed for transfer.</p> <p><b>15.1.8.2 Transfer Height.</b> The height of the amusement ride seats shall be 14 inches (355 mm) minimum to 24 inches (610mm) maximum measured above the load and unload surface.</p> <p><b>15.1.8.3 Transfer Entry.</b> Where openings are provided to transfer to amusement ride seats, the space shall be designed to provide clearance for transfer from a wheelchair or mobility device to the amusement ride seat.</p> <p><b>15.1.8.4 Wheelchair Storage Space.</b> Wheelchair storage spaces complying with 4.2.4 shall be provided in or adjacent to unload areas for each required amusement ride seat designed for transfer and shall not overlap any required means of egress or accessible route.</p> <p><b>15.1.9* Transfer Devices for Use with Amusement Rides.</b> Transfer devices for use with amusement rides shall comply with 15.1.9 when positioned for loading and unloading.</p> <p><b>15.1.9.1 Clear Floor or Ground Space.</b> Clear floor or ground space complying with 4.2.4 shall be provided in the load and unload area adjacent to the transfer devices.</p> <p><b>15.1.9.2 Transfer Height.</b> The height of the transfer device seats shall be 14 inches (355 mm) minimum to 24 inches (610 mm) maximum measured above the load and unload surface.</p> <p><b>15.1.9.3 Wheelchair Storage Space.</b> Wheelchair storage spaces complying with 4.2.4 shall be provided in or adjacent to unload areas for each required transfer device and shall not overlap any required means of egress or accessible route.</p>
<p align="center"><b>Fig. 58</b> Protrusions in Wheelchair Spaces</p>	
<p><b>15.1.7.3 Openings.</b> Where openings are provided to access wheelchair spaces on amusement rides, the entry shall provide a 32 inch (815 mm) minimum clear opening.</p> <p><b>15.1.7.4 Approach.</b> One side of the wheelchair space shall adjoin an accessible route.</p> <p><b>15.1.7.5 Companion Seats.</b> Where the interior width of the amusement ride is greater than 53 inches (1346 mm), seating is provided for more than one rider, and the wheelchair is not required to be centered within the amusement ride, a companion seat shall be provided for each wheelchair space.</p> <p><b>15.1.7.5.1 Shoulder-to-Shoulder Seating.</b> Where an amusement ride provides shoulder-to-shoulder seating, companion seats shall be shoulder-to-shoulder with the adjacent wheelchair space.</p> <p>EXCEPTION: Where shoulder-to-shoulder companion seating is not operationally or structurally feasible, compliance with this provision shall be required to the maximum extent feasible.</p>	

15.2 Boating Facilities

<p><b>15.2 Boating Facilities.</b></p> <p><b>15.2.1 General.</b> Newly designed or newly constructed and altered boating facilities shall comply with 15.2.</p> <p><b>15.2.2* Accessible Route.</b> Accessible routes, including gangways that are part of accessible routes, shall comply with 4.3.</p> <p>EXCEPTION 1: Where an existing gangway or series of gangways is replaced or altered, an increase in the length of the gangway is not required to comply with 15.2.2, unless required by 4.1.6(2).</p> <p>EXCEPTION 2: The maximum rise specified in 4.8.2 shall not apply to gangways.</p> <p>EXCEPTION 3: Where the total length of the gangway or series of gangways serving as part of a required accessible route is at least 80 feet (24 m), the maximum slope specified in 4.8.2 shall not apply to the gangways.</p> <p>EXCEPTION 4: In facilities containing fewer than 25 boat slips and where the total length of the gangways or series of gangways serving as part of a required accessible route is at least 30 feet (9140 mm), the maximum slope specified in 4.8.2 shall not apply to the gangways.</p> <p>EXCEPTION 5: Where gangways connect to transition plates, landings specified by 4.8.4 shall not be required.</p> <p>EXCEPTION 6: Where gangways and transition plates connect and are required to have handrails, handrail extensions specified by 4.8.5 shall not be required. Where handrail extensions are provided on gangways or transition plates, such extensions are not required to be parallel with the ground or floor surface.</p> <p>EXCEPTION 7: The cross slope of gangways, transition plates, and floating piers that are part of an accessible route shall be 1:50 maximum measured in the static position.</p>	<p>EXCEPTION 8: Limited-use/limited-application elevators or platform lifts complying with 4.11 shall be permitted in lieu of gangways complying with 4.3.</p> <p><b>15.2.3* Boat Slips: Minimum Number.</b> Where boat slips are provided, boat slips complying with 15.2.5 shall be provided in accordance with Table 15.2.3. Where the number of boat slips is not identified, each 40 feet (12 m) of boat slip edge provided along the perimeter of the pier shall be counted as one boat slip for the purpose of this section.</p> <p style="text-align: center;"><b>Table 15.2.3</b></p> <table border="1" style="margin-left: auto; margin-right: auto;"> <thead> <tr> <th style="text-align: center;">Total Boat Slips in Facility</th> <th style="text-align: center;">Minimum Number of Required Accessible Boat Slips</th> </tr> </thead> <tbody> <tr><td style="text-align: center;">1 to 25</td><td style="text-align: center;">1</td></tr> <tr><td style="text-align: center;">26 to 50</td><td style="text-align: center;">2</td></tr> <tr><td style="text-align: center;">51 to 100</td><td style="text-align: center;">3</td></tr> <tr><td style="text-align: center;">101 to 150</td><td style="text-align: center;">4</td></tr> <tr><td style="text-align: center;">151 to 300</td><td style="text-align: center;">5</td></tr> <tr><td style="text-align: center;">301 to 400</td><td style="text-align: center;">6</td></tr> <tr><td style="text-align: center;">401 to 500</td><td style="text-align: center;">7</td></tr> <tr><td style="text-align: center;">501 to 600</td><td style="text-align: center;">8</td></tr> <tr><td style="text-align: center;">601 to 700</td><td style="text-align: center;">9</td></tr> <tr><td style="text-align: center;">701 to 800</td><td style="text-align: center;">10</td></tr> <tr><td style="text-align: center;">801 to 900</td><td style="text-align: center;">11</td></tr> <tr><td style="text-align: center;">901 to 1000</td><td style="text-align: center;">12</td></tr> <tr><td style="text-align: center;">1001 and over</td><td style="text-align: center;">12 plus 1 for each 100 or fraction thereof over 1000</td></tr> </tbody> </table> <p><b>15.2.3.1* Dispersion.</b> Accessible boat slips shall be dispersed throughout the various types of slips provided. This provision does not require an increase in the minimum number of boat slips required to be accessible.</p> <p><b>15.2.4* Boarding Piers at Boat Launch Ramps.</b> Where boarding piers are provided at boat launch ramps, at least 5 percent, but not less than one of the boarding piers shall comply with 15.2.4 and shall be served by an accessible route complying with 4.3.</p>	Total Boat Slips in Facility	Minimum Number of Required Accessible Boat Slips	1 to 25	1	26 to 50	2	51 to 100	3	101 to 150	4	151 to 300	5	301 to 400	6	401 to 500	7	501 to 600	8	601 to 700	9	701 to 800	10	801 to 900	11	901 to 1000	12	1001 and over	12 plus 1 for each 100 or fraction thereof over 1000
Total Boat Slips in Facility	Minimum Number of Required Accessible Boat Slips																												
1 to 25	1																												
26 to 50	2																												
51 to 100	3																												
101 to 150	4																												
151 to 300	5																												
301 to 400	6																												
401 to 500	7																												
501 to 600	8																												
601 to 700	9																												
701 to 800	10																												
801 to 900	11																												
901 to 1000	12																												
1001 and over	12 plus 1 for each 100 or fraction thereof over 1000																												

**15.2 Boating Facilities**

**EXCEPTION 1:** Accessible routes serving floating boarding piers shall be permitted to use exceptions 1, 2, 5, 6, 7, and 8 in 15.2.2.

**EXCEPTION 2:** Where the total length of the gangway or series of gangways serving as part of a required accessible route is at least 30 feet (9140 mm), the maximum slope specified by 4.8.2 shall not apply to the gangways.

**EXCEPTION 3:** Where the accessible route serving a floating boarding pier or skid pier is located within a boat launch ramp, the portion of the accessible route located within the boat launch ramp shall not be required to comply with 4.8.

**15.2.4.1\* Boarding Pier Clearances.** The entire length of the piers shall comply with 15.2.5.

**15.2.5\* Accessible Boat Slips.** Accessible boat slips shall comply with 15.2.5.

**15.2.5.1 Clearances.** Accessible boat slips shall be served by clear pier space 60 inches (1525 mm) wide minimum and at least as long as the accessible boat slips. Every 10 feet (3050 mm) maximum of linear pier edge serving the accessible boat slips shall contain at least one continuous clear opening 60 inches (1525 mm) minimum in width (see Fig. 59).

**EXCEPTION 1:** The width of the clear pier space shall be permitted to be 36 inches (915 mm) minimum for a length of 24 inches (610 mm) maximum, provided that multiple 36 inch (915 mm) wide segments are separated by segments that are 60 inches (1525 mm) minimum clear in width and 60 inches (1525 mm) minimum clear in length (see Fig. 60).

**EXCEPTION 2:** Edge protection 4 inches (100 mm) high maximum and 2 inches (51 mm) deep maximum shall be permitted at the continuous clear openings (see Fig. 61).

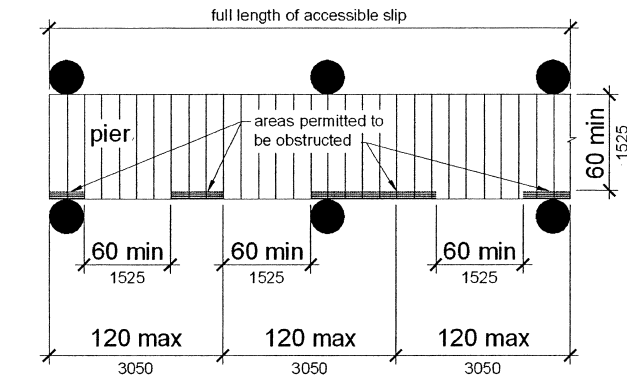

**Fig. 59**  
**Pier Clearances**



15.3 Fishing Piers and Platforms

**EXCEPTION 3\*:** In alterations to existing facilities, clear pier space shall be permitted to be located perpendicular to the boat slip and shall extend the width of the boat slip, where the facility has at least one boat slip complying with 15.2.5, and further compliance with 15.2.5 would result in a reduction in the number of boat slips available or result in a reduction of the widths of existing slips.

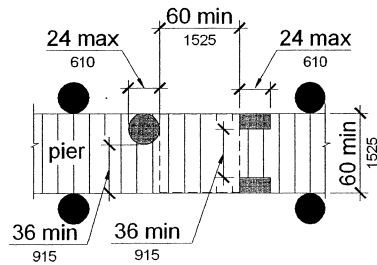

Fig. 60  
Pier Clear Space Reduction

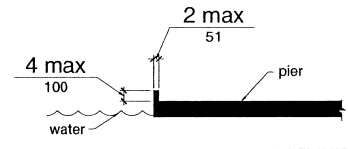

Fig. 61  
Edge Protection at Pier

**15.2.5.2 Cleats and Other Boat Securement Devices.** Cleats and other boat securement devices shall not be required to comply with 4.27.3.

**15.3 Fishing Piers and Platforms.**

**15.3.1 General.** Newly designed or newly constructed and altered fishing piers and platforms shall comply with 15.3.

**15.3.2 Accessible Route.** Accessible routes, including gangways that are part of accessible routes, serving fishing piers and platforms shall comply with 4.3.

**EXCEPTION 1:** Accessible routes serving floating fishing piers and platforms shall be permitted to use exceptions 1, 2, 5, 6, 7, and 8 in 15.2.2.

**EXCEPTION 2\*:** Where the total length of the gangway or series of gangways serving as part of a required accessible route is at least 30 feet (9140 mm), the maximum slope specified by 4.8.2 shall not apply to the gangways.

**15.3.3 Railings.** Where railings, guards, or handrails are provided, they shall comply with 15.3.3.

**15.3.3.1\* Edge Protection.** Edge protection shall be provided and shall extend 2 inches (51 mm) minimum above the ground or deck surface.

**EXCEPTION:** Where the railing, guard, or handrail is 34 inches (865 mm) or less above the ground or deck surface, edge protection shall not be required if the deck surface extends 12 inches (305 mm) minimum beyond the inside face of the railing. Toe clearance shall be 9 inches (230 mm) minimum above the ground or deck surface beyond the railing. Toe clearance shall be 30 inches (760 mm) minimum wide (see Fig. 62).

**15.3.3.2 Height.** At least 25 percent of the railings, guards, or handrails shall be 34 inches (865 mm) maximum above the ground or deck surface.

**EXCEPTION:** This provision shall not apply to that portion of a fishing pier or platform where a guard which complies with sections 1003.2.12.1 (Height) and 1003.2.12.2 (Opening limitations) of the International Building Code (incorporated by reference, see 2.3.2) is provided.

15.4 Golf

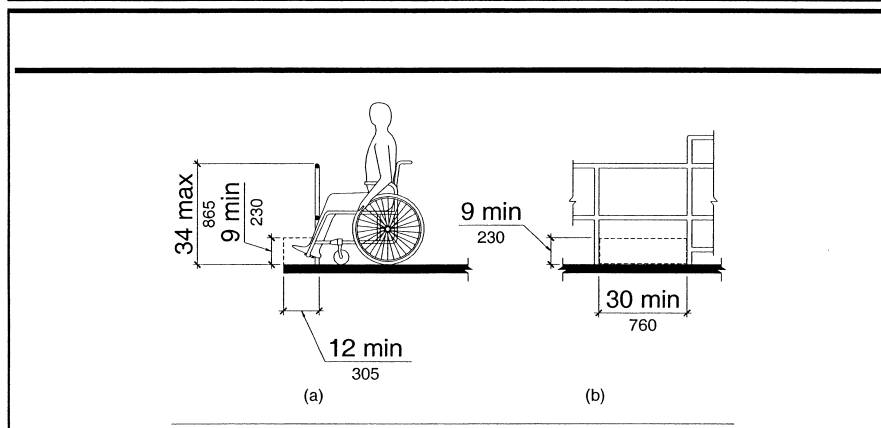

Fig. 62  
Edge Protection at Fishing Piers

**15.3.3.3\* Dispersion.** Railings required to comply with 15.3.3.2 shall be dispersed throughout a fishing pier or platform.

**15.3.4 Clear Floor or Ground Space.** At least one clear floor or ground space complying with 4.2.4 shall be provided where the railing height required by 15.3.3.2 is located. Where no railings are provided, at least one clear floor or ground space complying with 4.2.4 shall be provided.

**15.3.5 Maneuvering Space.** At least one maneuvering space complying with 4.2.3 shall be provided on the fishing pier or platform.

**15.4 Golf.**

**15.4.1 General.** Newly designed or newly constructed and altered golf courses, driving ranges, practice putting greens, and practice teeing grounds shall comply with 15.4.

**15.4.2\* Accessible Route - Golf Course.** An accessible route shall connect accessible elements and spaces within the boundary of the golf course.

In addition, an accessible route shall connect the golf car rental area, bag drop areas, practice putting greens, accessible practice teeing grounds, course toilet rooms, and course weather shelters. The accessible route required by this section shall be 48 inches (1220 mm) minimum wide. Where handrails are provided, the accessible route shall be 60 inches (1525 mm) minimum wide.

**EXCEPTION 1:** A golf car passage complying with 15.4.7 shall be permitted in lieu of all or part of an accessible route required by 15.4.2.

**EXCEPTION 2:** The handrail requirements of 4.8.5 shall not apply to an accessible route located within the boundary of a golf course.

**15.4.3\* Accessible Route - Driving Ranges.** An accessible route shall connect accessible teeing stations at driving ranges with accessible parking spaces and shall be 48 inches (1220 mm) wide minimum. Where handrails are provided, the accessible route shall be 60 inches (1525 mm) wide minimum.

15.5 Miniature Golf

<p>EXCEPTION: A golf car passage complying with 15.4.7 shall be permitted in lieu of all or part of an accessible route required by 15.4.3.</p> <p><b>15.4.4 Teeing Grounds.</b> Teeing grounds shall comply with 15.4.4.</p> <p><b>15.4.4.1 Number Required.</b> Where one or two teeing grounds are provided for a hole, at least one teeing ground serving the hole shall comply with 15.4.4.3. Where three or more teeing grounds are provided for a hole, at least two teeing grounds shall comply with 15.4.4.3.</p> <p><b>15.4.4.2 Forward Teeing Ground.</b> The forward teeing ground shall be accessible.</p> <p>EXCEPTION: In alterations, the forward teeing ground shall not be required to be accessible where compliance is not feasible due to terrain.</p> <p><b>15.4.4.3 Teeing Grounds.</b> Teeing grounds required by 15.4.4.1 and 15.4.4.2 shall be designed and constructed so that a golf car can enter and exit the teeing ground.</p> <p><b>15.4.5 Teeing Stations at Driving Ranges and Practice Teeing Grounds.</b> Where teeing stations or practice teeing grounds are provided, at least 5 percent of the practice teeing stations or practice teeing grounds, but not less than one, shall comply with 15.4.4.3.</p> <p><b>15.4.6 Weather Shelters.</b> Where weather shelters are provided on a golf course, each weather shelter shall have a clear floor or ground space 60 inches (1525 mm) minimum by 96 inches (2440 mm) minimum and shall be designed and constructed so that a golf car can enter and exit.</p> <p><b>15.4.7 Golf Car Passage.</b> Where curbs or other constructed barriers are provided along a golf car passage to prohibit golf cars from entering a fairway, openings at least 60 inches (1525 mm) wide shall be provided at intervals not to exceed 75 yds (69 m).</p> <p><b>15.4.7.1 Width.</b> The golf car passage shall be 48 inches (1220 mm) minimum wide.</p>	<p><b>15.4.8 Putting Greens.</b> Each putting green shall be designed and constructed so that a golf car can enter and exit the putting green.</p> <p><b>15.5* Miniature Golf.</b></p> <p><b>15.5.1 General.</b> Newly designed or newly constructed and altered miniature golf courses shall comply with 15.5.</p> <p><b>15.5.2 Accessible Holes.</b> At least fifty percent of holes on a miniature golf course shall comply with 15.5.3 through 15.5.5 and shall be consecutive.</p> <p>EXCEPTION: One break in the sequence of consecutive accessible holes shall be permitted, provided that the last hole on a miniature golf course is the last hole in the sequence.</p> <p><b>15.5.3* Accessible Route.</b> An accessible route complying with 4.3 shall connect the course entrance with the first accessible hole and the start of play area on each accessible hole. The course shall be configured to allow exit from the last accessible hole to the course exit or entrance and shall not require travel back through other holes.</p> <p><b>15.5.3.1 Accessible Route - Located On the Playing Surface.</b> Where the accessible route is located on the playing surface of the accessible hole, exceptions 1-5 shall be permitted.</p> <p>EXCEPTION 1: Where carpet is provided, the requirements of 4.5.3 shall not apply.</p> <p>EXCEPTION 2: Where the accessible route intersects the playing surface of a hole, a 1 inch (26 mm) maximum curb shall be permitted for a width of 32 inches (815 mm) minimum.</p> <p>EXCEPTION 3: A slope of 1:4 maximum for a 4 inch (100 mm) maximum rise shall be permitted.</p> <p>EXCEPTION 4: Landings required by 4.8.4 shall be permitted to be 48 inches (1220 mm) in length minimum. Landing size required by 4.8.4(3) shall be permitted to be 48 inches (1220 mm) minimum by 60 inches (1525 mm) minimum.</p>
---	---

**15.6 Play Areas**

Landing slopes shall be permitted to be 1:20 maximum.

EXCEPTION 5: Handrail requirements of 4.8.5 shall not apply.

**15.5.3.2 Accessible Route - Adjacent to the Playing Surface.** Where the accessible route is located adjacent to the playing surface, the requirements of 4.3 shall apply.

**15.5.4 Start of Play Areas.** Start of play areas at holes required to comply with 15.5.2 shall have a slope not steeper than 1:48 and shall be 48 inches (1220 mm) minimum by 60 inches (1525 mm) minimum.

**15.5.5\* Golf Club Reach Range.** All areas within accessible holes where golf balls rest shall be within 36 inches (915 mm) maximum of an accessible route having a maximum slope of 1:20 for 48 inches (1220 mm) in length (see Fig. 63).

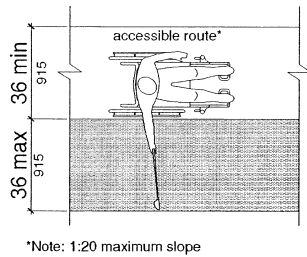

Fig. 63  
Golf Club Reach Range

**15.6 Play Areas.**

**15.6.1\* General.** Newly designed and newly constructed play areas for children ages 2 and over and altered portions of existing play areas shall comply with the applicable provisions of section 4, except as modified or otherwise provided by this section. Where separate play

areas are provided within a site for specified age groups, each play area shall comply with this section. Where play areas are designed or constructed in phases, this section shall be applied so that when each successive addition is completed, the entire play area complies with all the applicable provisions of this section.

EXCEPTION 1: Play areas located in family child care facilities where the proprietor actually resides shall not be required to comply with 15.6.

EXCEPTION 2: Where play components are relocated in existing play areas for the purpose of creating safe use zones, 15.6 shall not apply, provided that the ground surface is not changed or extended for more than one use zone.

EXCEPTION 3: Where play components are altered and the ground surface is not altered, the ground surface shall not be required to comply with 15.6.7, unless required by 4.1.6(2).

EXCEPTION 4: The provisions of 15.6.1 through 15.6.7 shall not apply to amusement attractions.

EXCEPTION 5: Compliance with 4.4 shall not be required within the boundary of the play area.

EXCEPTION 6: Stairs shall not be required to comply with 4.9.

**15.6.2\* Ground Level Play Components.**

Ground level play components shall be provided in the number and types required by 15.6.2.1 and 15.6.2.2. Ground level play components that are provided to comply with 15.6.2.1 shall be permitted to satisfy the number required by 15.6.2.2, provided that the minimum required types of play components are provided. Where more than one ground level play component required by 15.6.2.1 and 15.6.2.2 is provided, the play components shall be integrated in the play area.

**15.6.2.1 General.** Where ground level play components are provided, at least one of each type provided shall be located on an accessible route complying with 15.6.4 and shall comply with 15.6.6.

15.6 Play Areas

<p><b>15.6.2.2 Additional Number and Types.</b> Where elevated play components are provided, ground level play components shall be provided in accordance with Table 15.6.2.2. Ground level play components required by 15.6.2.2 shall be located on an accessible route complying with 15.6.4 and shall comply with 15.6.6.</p> <p>EXCEPTION: If at least 50 percent of the elevated play components are connected by a ramp, and if at least 3 of the elevated play components connected by the ramp are different types of play components, 15.6.2.2 shall not apply.</p> <p><b>15.6.3* Elevated Play Components.</b> Where elevated play components are provided, at least 50 percent shall be located on an accessible route complying with 15.6.4. Elevated play components connected by a ramp shall comply with 15.6.6.</p>	<p><b>15.6.4* Accessible Routes.</b> At least one accessible route complying with 4.3, as modified by 15.6.4, shall be provided.</p> <p>EXCEPTION 1: Transfer systems complying with 15.6.5 shall be permitted to connect elevated play components, except where 20 or more elevated play components are provided, no more than 25 percent of the elevated play components shall be permitted to be connected by transfer systems.</p> <p>EXCEPTION 2: Where transfer systems are provided, an elevated play component shall be permitted to connect to another elevated play component in lieu of an accessible route.</p> <p>EXCEPTION 3: Platform lifts (wheelchair lifts) complying with 4.11 and applicable State or local codes shall be permitted to be used as part of an accessible route.</p>	
<p><b>Table 15.6.2.2 Number and Types of Ground Level Play Components Required to be on Accessible Route</b></p>		
<p><b>Number of Elevated Play Components Provided</b></p>	<p><b>Minimum Number of Ground Level Play Components Required to be on Accessible Route</b></p>	<p><b>Minimum Number of Different Types of Ground Level Play Components Required to be on Accessible Route</b></p>
1	Not applicable	Not applicable
2 to 4	1	1
5 to 7	2	2
8 to 10	3	3
11 to 13	4	3
14 to 16	5	3
17 to 19	6	3
20 to 22	7	4
23 to 25	8	4
More than 25	8 plus 1 for each additional 3 over 25, or fraction thereof	5

**15.6 Play Areas**

<p><b>15.6.4.1 Location.</b> Accessible routes shall be located within the boundary of the play area and shall connect ground level play components as required by 15.6.2.1 and 15.6.2.2 and elevated play components as required by 15.6.3, including entry and exit points of the play components.</p> <p><b>15.6.4.2 Protrusions.</b> Objects shall not protrude into ground level accessible routes at or below 80 in (2030 mm) above the ground or floor surface.</p> <p><b>15.6.4.3 Clear Width.</b> The clear width of accessible routes within play areas shall comply with 15.6.4.3.</p> <p><b>15.6.4.3.1 Ground Level.</b> The clear width of accessible routes at ground level shall be 60 in (1525 mm) minimum.</p> <p>EXCEPTION 1: In play areas less than 1,000 square feet, the clear width of accessible routes shall be permitted to be 44 in (1120 mm) minimum, provided that at least one turning space complying with 4.2.3 is provided where the restricted accessible route exceeds 30 feet (9.14 m) in length.</p> <p>EXCEPTION 2: The clear width of accessible routes shall be permitted to be 36 in (915 mm) minimum for a distance of 60 in (1525 mm) maximum, provided that multiple reduced width segments are separated by segments that are 60 in (1525 mm) minimum in width and 60 in (1525 mm) minimum in length.</p> <p><b>15.6.4.3.2 Elevated.</b> The clear width of accessible routes connecting elevated play components shall be 36 in (915 mm).</p> <p>EXCEPTION 1: The clear width of accessible routes connecting elevated play components shall be permitted to be reduced to 32 in (815 mm) minimum for a distance of 24 in (610 mm) maximum provided that reduced width segments are separated by segments that are 48 in (1220 mm) minimum in length and 36 in (915 mm) minimum in width.</p> <p>EXCEPTION 2: The clear width of transfer systems connecting elevated play components</p>	<p>shall be permitted to be 24 in (610 mm) minimum.</p> <p><b>15.6.4.4 Ramp Slope and Rise.</b> Any part of an accessible route with a slope greater than 1:20 shall be considered a ramp and shall comply with 4.8, as modified by 15.6.4.4.</p> <p><b>15.6.4.4.1 Ground Level.</b> The maximum slope for ramps connecting ground level play components within the boundary of a play area shall be 1:16.</p> <p><b>15.6.4.4.2 Elevated.</b> Where a ramp connects elevated play components, the maximum rise of any ramp run shall be 12 in (305 mm).</p> <p><b>15.6.4.5 Handrails.</b> Where required on ramps, handrails shall comply with 4.8.5, as modified by 15.6.4.5.</p> <p>EXCEPTION 1: Handrails shall not be required at ramps located within ground level use zones.</p> <p>EXCEPTION 2: Handrail extensions shall not be required.</p> <p><b>15.6.4.5.1 Handrail Gripping Surface.</b> Handrails shall have a diameter or width of 0.95 in (24.1 mm) minimum to 1.55 in (39.4 mm) maximum, or the shape shall provide an equivalent gripping surface.</p> <p><b>15.6.4.5.2 Handrail Height.</b> The top of handrail gripping surfaces shall be 20 in (510 mm) minimum to 28 in (710 mm) maximum above the ramp surface.</p> <p><b>15.6.5* Transfer Systems.</b> Where transfer systems are provided to connect elevated play components, the transfer systems shall comply with 15.6.5.</p> <p><b>15.6.5.1 Transfer Platforms.</b> Transfer platforms complying with 15.6.5.1 shall be provided where transfer is intended to be from a wheelchair or other mobility device (see Fig. 64).</p>
---	---

15.6 Play Areas

<p style="text-align: center;">(a)</p> <p style="text-align: center;">(b)</p> <p style="text-align: center;">Fig. 64</p>	<p><b>15.6.5.1.4 Transfer Supports.</b> A means of support for transferring shall be provided.</p> <p><b>15.6.5.2 Transfer Steps.</b> Transfer steps complying with 15.6.5.2 shall be provided where movement is intended from a transfer platform to a level with elevated play components required to be located on an accessible route (see Fig. 65).</p> <hr/> <p style="text-align: center;">(a)</p> <p style="text-align: center;">(b)</p> <p style="text-align: center;">Fig. 65</p>
<p><b>15.6.5.1.1 Size.</b> Platforms shall have a level surface 14 in (355 mm) minimum in depth and 24 in (610 mm) minimum in width.</p> <p><b>15.6.5.1.2 Height.</b> Platform surfaces shall be 11 in (280 mm) minimum to 18 in (455 mm) maximum above the ground or floor surface.</p> <p><b>15.6.5.1.3 Transfer Space.</b> A level space complying with 4.2.4 shall be centered on the 48 in (1220 mm) long dimension parallel to the 24 in (610 mm) minimum long unobstructed side of the transfer platform.</p>	<p><b>15.6.5.2.1 Size.</b> Transfer steps shall have a level surface 14 in (355 mm) minimum in depth and 24 in (610 mm) minimum in width.</p> <p><b>15.6.5.2.2 Height.</b> Each transfer step shall be 8 in (205 mm) maximum high.</p> <p><b>15.6.5.2.3 Transfer Supports.</b> A means of support for transferring shall be provided.</p> <p><b>15.6.6* Play Components.</b> Ground level play components located on accessible routes and</p>

**15.7 Exercise Equipment and Machines**

<p>elevated play components connected by ramps shall comply with 15.6.6.</p> <p><b>15.6.6.1 Maneuvering Space.</b> Maneuvering space complying with 4.2.3 shall be provided on the same level as the play components. Maneuvering space shall have a slope not steeper than 1:48 in all directions. The maneuvering space required for a swing shall be located immediately adjacent to the swing.</p> <p><b>15.6.6.2 Clear Floor or Ground Space.</b> Clear floor or ground space shall be provided at the play components and shall be 30 in (760 mm) by 48 in (1220 mm) minimum. Clear floor or ground space shall have a slope not steeper than 1:48 in all directions.</p> <p><b>15.6.6.3 Play Tables: Height and Clearances.</b> Where play tables are provided, knee clearance 24 in (610 mm) high minimum, 17 in deep (430 mm) minimum, and 30 in (760 mm) wide minimum shall be provided. The tops of rims, curbs, or other obstructions shall be 31 in (785 mm) high maximum.</p> <p>EXCEPTION: Play tables designed or constructed primarily for children ages 5 and under shall not be required to provide knee clearance if the clear floor or ground space required by 15.6.6.2 is arranged for a parallel approach and if the rim surface is 31 in (785 mm) high maximum.</p> <p><b>15.6.6.4 Entry Points and Seats: Height.</b> Where a play component requires transfer to the entry point or seat, the entry point or seat shall be 11 in (280 mm) minimum and 24 in (610 mm) maximum above the clear floor or ground space.</p> <p>EXCEPTION: The entry point of a slide shall not be required to comply with 15.6.6.4.</p> <p><b>15.6.6.5 Transfer Supports.</b> Where a play component requires transfer to the entry point or seat, a means of support for transferring shall be provided.</p> <p><b>15.6.7* Ground Surfaces.</b> Ground surfaces along accessible routes, clear floor or ground</p>	<p>spaces, and maneuvering spaces within play areas shall comply with 4.5.1 and 15.6.7.</p> <p><b>15.6.7.1 Accessibility.</b> Ground surfaces shall comply with ASTM F 1951 Standard Specification for Determination of Accessibility of Surface Systems Under and Around Playground Equipment (incorporated by reference, see 2.3.2). Ground surfaces shall be inspected and maintained regularly and frequently to ensure continued compliance with ASTM F 1951.</p> <p><b>15.6.7.2 Use Zones.</b> If located within use zones, ground surfaces shall comply with ASTM F 1292 Standard Specification for Impact Attenuation of Surface Systems Under and Around Playground Equipment (incorporated by reference, see 2.3.2).</p> <p><b>15.6.8 Soft Contained Play Structures.</b> Soft contained play structures shall comply with 15.6.8.</p> <p><b>15.6.8.1 Accessible Routes to Entry Points.</b> Where three or fewer entry points are provided, at least one entry point shall be located on an accessible route. Where four or more entry points are provided, at least two entry points shall be located on an accessible route. Accessible routes shall comply with 4.3.</p> <p>EXCEPTION: Transfer systems complying with 15.6.5 or platform lifts (wheelchair lifts) complying with 4.11 and applicable State or local codes shall be permitted to be used as part of an accessible route.</p> <p><b>15.7 Exercise Equipment and Machines, Bowling Lanes, and Shooting Facilities.</b></p> <p><b>15.7.1 General.</b> Newly designed or newly constructed and altered exercise equipment and machines, bowling lanes, and shooting facilities shall comply with 15.7.</p> <p><b>15.7.2* Exercise Equipment and Machines.</b> At least one of each type of exercise equipment and machines shall be provided with clear floor or ground space complying with 4.2.4 and shall be served by an accessible route. Clear floor or ground space shall be positioned for transfer or</p>
--	--



**15.8 Swimming Pools, Wading Pools, and Spas**

<p>for use by an individual seated in a wheelchair. Clear floor or ground spaces for more than one piece of equipment shall be permitted to overlap</p> <p><b>15.7.3 Bowling Lanes.</b> Where bowling lanes are provided, at least 5 percent, but not less than one of each type of lane shall be served by an accessible route.</p> <p><b>15.7.4* Shooting Facilities.</b> Where fixed firing positions are provided at a site, at least 5 percent, but not less than one, of each type of firing position shall comply with 15.7.4.1.</p> <p><b>15.7.4.1 Fixed Firing Position.</b> Fixed firing positions shall contain a 60 inch (1525 mm) diameter space and shall have a slope not steeper than 1:48.</p> <p><b>15.8 Swimming Pools, Wading Pools, and Spas.</b></p> <p><b>15.8.1 General.</b> Newly designed or newly constructed and altered swimming pools, wading pools, and spas shall comply with 15.8.</p> <p>EXCEPTION: An accessible route shall not be required to serve raised diving boards or diving platforms.</p> <p><b>15.8.2* Swimming Pools.</b> At least two accessible means of entry shall be provided for each public use and common use swimming pool. The primary means of entry shall comply with 15.8.5 (Swimming Pool Lifts) or 15.8.6 (Sloped Entries). The secondary means of entry shall comply with one of the following: 15.8.5 (Swimming Pool Lifts), 15.8.6 (Sloped Entries), 15.8.7 (Transfer Walls), 15.8.8 (Transfer Systems), or 15.8.9 (Pool Stairs).</p> <p>EXCEPTION 1*: Where a swimming pool has less than 300 linear feet (91 m) of swimming pool wall, at least one accessible means of entry shall be provided and shall comply with 15.8.5 (Swimming Pool Lifts) or 15.8.6 (Sloped Entries).</p> <p>EXCEPTION 2: Wave action pools, leisure rivers, sand bottom pools, and other pools where user access is limited to one area, shall provide at least one accessible means of entry that complies with</p>	<p>15.8.5 (Swimming Pool Lifts), 15.8.6 (Sloped Entries), or 15.8.8 (Transfer Systems).</p> <p>EXCEPTION 3: Catch pools shall be required only to be served by an accessible route that connects to the pool edge.</p> <p><b>15.8.3 Wading Pools.</b> At least one accessible means of entry complying with 15.8.6 (Sloped Entries) shall be provided for each wading pool.</p> <p><b>15.8.4 Spas.</b> At least one accessible means of entry complying with 15.8.5 (Swimming Pool Lifts), 15.8.7 (Transfer Walls), or 15.8.8 (Transfer Systems) shall be provided for each spa.</p> <p>EXCEPTION: Where spas are provided in a cluster, 5 percent, but not less than one, in each cluster shall be accessible.</p> <p><b>15.8.5* Pool Lifts.</b> Pool lifts shall comply with 15.8.5.</p> <p><b>15.8.5.1 Pool Lift Location.</b> Pool lifts shall be located where the water level does not exceed 48 inches (1220 mm).</p> <p>EXCEPTION 1: Where the entire pool depth is greater than 48 inches (1220 mm), 15.8.5.1 shall not apply.</p> <p>EXCEPTION 2: Where multiple pool lift locations are provided, no more than one shall be required to be located in an area where the water level does not exceed 48 inches (1220 mm).</p> <p><b>15.8.5.2 Seat Location.</b> In the raised position, the centerline of the seat shall be located over the deck and 16 inches (405 mm) minimum from the edge of the pool. The deck surface between the centerline of the seat and the pool edge shall have a slope not greater than 1:48 (see Fig. 68).</p>
---	---

**15.8 Swimming Pools, Wading Pools, and Spas**

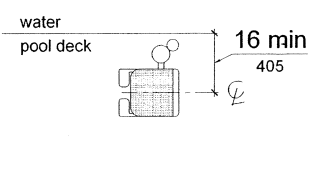
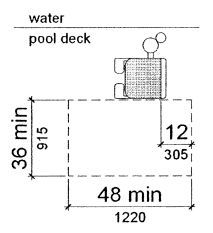
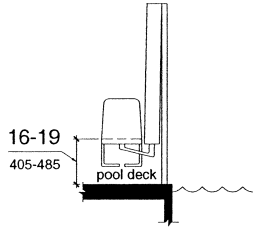
 <p style="text-align: center;"><b>Fig. 68</b> Pool Lift Seat Location</p>	<p>surface when in the raised (load) position (see Fig. 70).</p> <p><b>15.8.5.5 Seat Width.</b> The seat shall be 16 inches (405 mm) minimum wide.</p> <p><b>15.8.5.6* Footrests and Armrests.</b> Footrests shall be provided and shall move with the seat. If provided, armrests positioned opposite the water shall be removable or shall fold clear of the seat when the seat is in the raised (load) position.</p> <p>EXCEPTION: Footrests shall not be required on pool lifts provided in spas.</p> <p><b>15.8.5.7* Operation.</b> The lift shall be capable of unassisted operation from both the deck and water levels. Controls and operating mechanisms shall be unobstructed when the lift is in use and shall comply with 4.27.4.</p> <p><b>15.8.5.8 Submerged Depth.</b> The lift shall be designed so that the seat will submerge to a water depth of 18 inches (455 mm) minimum below the stationary water level (see Fig. 71).</p> <p><b>15.8.5.9* Lifting Capacity.</b> Single person pool lifts shall have a minimum weight capacity of 300 lbs. (136 kg) and be capable of sustaining a static load of at least one and a half times the rated load.</p>
<p><b>15.8.5.3 Clear Deck Space.</b> On the side of the seat opposite the water, a clear deck space shall be provided parallel with the seat. The space shall be 36 inches (915 mm) wide minimum and shall extend forward 48 inches (1220 mm) minimum from a line located 12 inches (305 mm) behind the rear edge of the seat. The clear deck space shall have a slope not greater than 1:48 (see Fig. 69).</p>  <p style="text-align: center;"><b>Fig. 69</b> Clear Deck Space at Pool Lifts</p>	 <p style="text-align: center;"><b>Fig. 70</b> Pool Lift Seat Height</p>
<p><b>15.8.5.4 Seat Height.</b> The height of the lift seat shall be designed to allow a stop at 16 inches (405 mm) minimum to 19 inches (485 mm) maximum measured from the deck to the top of the seat</p>	

15.8 Swimming Pools, Wading Pools, and Spas

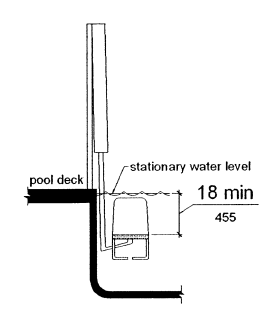
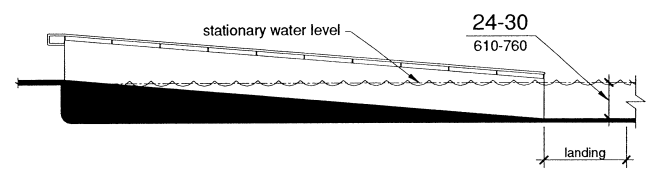
 <p style="text-align: center;">Fig 71 Pool Lift Submerged Depth</p>	<p>minimum to 30 inches (760 mm) maximum below the stationary water level. Where landings are required by 4.8, at least one landing shall be located 24 inches (610 mm) minimum to 30 inches (760 mm) maximum below the stationary water level (see Fig. 72).</p> <p>EXCEPTION: In wading pools, the sloped entry and landings, if provided, shall extend to the deepest part of the wading pool.</p> <p><b>15.8.6.3* Handrails.</b> Handrails shall be provided on both sides of the sloped entry and shall comply with 4.8.5. The clear width between handrails shall be 33 inches (840 mm) minimum and 38 inches (965 mm) maximum (see Fig. 73).</p> <p>EXCEPTION 1: Handrail extensions specified by 4.8.5 shall not be required at the bottom landing serving a sloped entry.</p> <p>EXCEPTION 2: Where a sloped entry is provided for wave action pools, leisure rivers, sand bottom pools, and other pools where user access is limited to one area, the required clear width between handrails shall not apply.</p> <p>EXCEPTION 3: The handrail requirements of 4.8.5 and 15.8.6.3 shall not be required on sloped entries in wading pools.</p>
<p><b>15.8.6 Sloped Entries.</b> Sloped entries designed to provide access into the water shall comply with 15.8.6.</p> <p><b>15.8.6.1* Sloped Entries.</b> Sloped entries shall comply with 4.3, except as modified below.</p> <p>EXCEPTION: Where sloped entries are provided, the surfaces shall not be required to be slip resistant.</p> <p><b>15.8.6.2 Submerged Depth.</b> Sloped entries shall extend to a depth of 24 inches (610 mm)</p>	
 <p style="text-align: center;">Fig. 72 Sloped Entry Submerged Depth</p>	

**15.8 Swimming Pools, Wading Pools, and Spas**

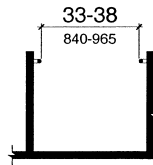

Fig. 73  
Sloped Entry Handrails

**15.8.7 Transfer Walls.** Transfer walls shall comply with 15.8.7.

**15.8.7.1 Clear Deck Space.** A clear deck space of 60 inches (1525 mm) minimum by 60 inches (1525 mm) minimum with a slope not steeper

than 1:48 shall be provided at the base of the transfer wall. Where one grab bar is provided, the clear deck space shall be centered on the grab bar. Where two grab bars are provided, the clear deck space shall be centered on the clearance between the grab bars (see Fig. 74).

**15.8.7.2 Height.** The height of the transfer wall shall be 16 inches (405 mm) minimum to 19 inches (485 mm) maximum measured from the deck (see Fig. 75).

**15.8.7.3 Wall Depth and Length.** The depth of the transfer wall shall be 12 inches (305 mm) minimum to 16 inches (405 mm) maximum. The length of the transfer wall shall be 60 inches (1525 mm) minimum and shall be centered on the clear deck space (see Fig. 76).

**15.8.7.4 Surface.** Surfaces of transfer walls shall not be sharp and shall have rounded edges.

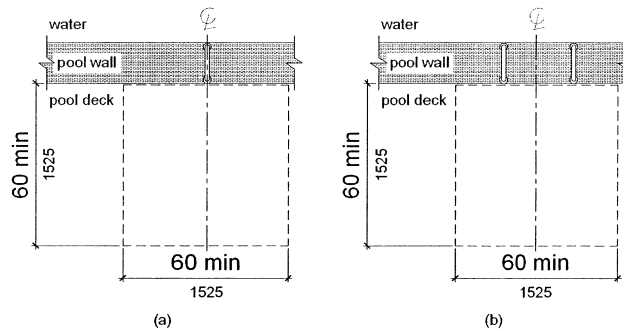

Fig. 74  
Clear Deck Space at Transfer Walls

15.8 Swimming Pools, Wading Pools, and Spas

**15.8.7.5 Grab Bars.** At least one grab bar shall be provided on the transfer wall. Grab bars shall be perpendicular to the pool wall and shall extend the full depth of the transfer wall. The top of the gripping surface shall be 4 inches (100 mm) minimum and 6 inches (150 mm) maximum above walls. Where one grab bar is provided, clearance shall be 24 inches (610 mm) minimum on both sides of the grab bar. Where two grab bars are provided, clearance between grab bars

shall be 24 inches (610 mm) minimum. Grab bars shall comply with 4.26 (see Fig. 77).

**15.8.8 Transfer Systems.** Transfer systems shall comply with 15.8.8.

**15.8.8.1 Transfer Platform.** A transfer platform 19 inches (485 mm) minimum clear depth by 24 inches (610 mm) minimum clear width shall be provided at the head of each transfer system (see Fig. 78).

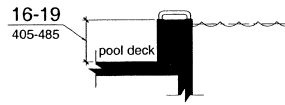

Fig. 75  
Transfer Wall Height

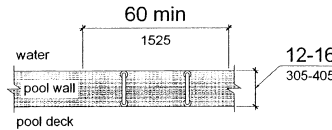

Fig. 76  
Transfer Wall Depth and Length

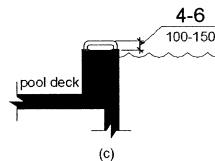
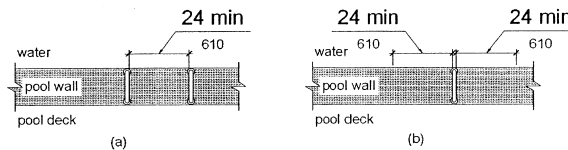

Fig. 77  
Grab Bars at Transfer Walls

**15.8 Swimming Pools, Wading Pools, and Spas**

<p style="text-align: center;">Fig. 78 Transfer System Platform</p>	<p>transfer platform surface and shall be centered along a 24 inch (610 mm) minimum unobstructed side of the transfer platform (see Fig. 79).</p> <p><b>15.8.8.3 Height.</b> The height of the transfer platform shall comply with 15.8.7.2.</p> <p><b>15.8.8.4* Transfer Steps.</b> Transfer step height shall be 8 inches (205 mm) maximum. Transfer steps shall extend to a water depth of 18 inches (455 mm) minimum below the stationary water level (see Fig. 80).</p> <p><b>15.8.8.5 Surface.</b> The surface of the transfer system shall not be sharp and shall have rounded edges.</p> <p><b>15.8.8.6 Size.</b> Each transfer step shall have a tread clear depth of 14 inches (355 mm) minimum and 17 inches (430 mm) maximum and shall have a tread clear width of 24 inches (610 mm) minimum (see Fig. 81).</p>
<p><b>15.8.8.2 Clear Deck Space.</b> A clear deck space of 60 inches (1525 mm) minimum by 60 inches (1525 mm) minimum with a slope not steeper than 1:48 shall be provided at the base of the</p>	

Fig. 79  
Clear Deck Space at Transfer Systems

15.8 Swimming Pools, Wading Pools, and Spas

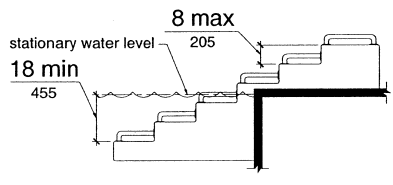
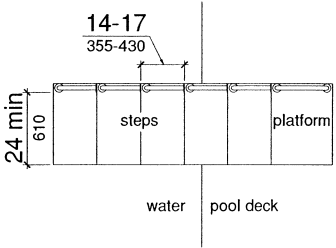
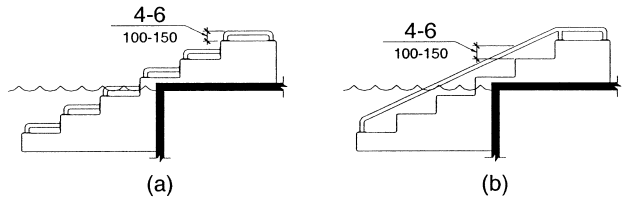
<p><b>15.8.8.7* Grab Bars.</b> At least one grab bar on each transfer step and the transfer platform, or a continuous grab bar serving each transfer step and the transfer platform, shall be provided. Where provided, the top of the gripping surface shall be 4 inches (100 mm) minimum and 6 inches (150 mm) maximum above each step and transfer platform. Where a continuous grab bar is</p>	<p>provided, the top of the gripping surface shall be 4 inches (100 mm) minimum and 6 inches (150 mm) maximum above the step nosing and transfer platform. Grab bars shall comply with 4.26 and be located on at least one side of the transfer system. The grab bar located at the transfer platform shall not obstruct transfer (see Fig. 82).</p>
 <p style="text-align: center;">Fig. 80 Transfer System Steps</p>	 <p style="text-align: center;">Fig. 81 Size of Transfer System Steps</p>
 <p style="text-align: center;">Fig. 82 Grab Bars at Transfer Systems</p>	

**15.8 Swimming Pools, Wading Pools, and Spas**

<p><b>15.8.9 Pool Stairs.</b> Pool stairs shall comply with 15.8.9.</p> <p><b>15.8.9.1 Pool Stairs.</b> Pool stairs shall comply with 4.9, except as modified below.</p> <p><b>15.8.9.2 Handrails.</b> The width between handrails shall be 20 inches (510 mm) minimum and 24 inches (610 mm) maximum. Handrail extensions required by 4.9.4 shall not be required at the bottom landing serving a pool stair.</p> <p><b>15.8.10* Water Play Components.</b> Where water play components are provided, the provisions of 15.6 and 4.3 shall apply, except as modified or otherwise provided in this section.</p> <p>EXCEPTION 1: Where the surface of the accessible route, clear floor or ground spaces and maneuvering spaces connecting play components is submerged, the provisions of 15.6 and 4.3 for cross slope, running slope, and surface shall not apply.</p> <p>EXCEPTION 2: Transfer systems complying with 15.6.5 shall be permitted to be used in lieu of ramps to connect elevated play components.</p>	
---	--



APPENDIX

<b>APPENDIX</b>											
<p>This appendix contains materials of an advisory nature and provides additional information that should help the reader to understand the minimum requirements of the guidelines or to design buildings or facilities for greater accessibility. The paragraph numbers correspond to the sections or paragraphs of the guideline to which the material relates and are therefore not consecutive (for example, A4.2.1 contains additional information relevant to 4.2.1). Sections of the guidelines for which additional material appears in this appendix have been indicated by an asterisk. Nothing in this appendix shall in any way obviate any obligation to comply with the requirements of the guidelines itself.</p> <p><b>A2.0 General.</b></p> <p><b>A2.2 Equivalent Facilitation.</b> Specific examples of equivalent facilitation are found in the following sections:</p> <table border="0"> <tr> <td style="padding-right: 20px;">4.1.6(3)(c)</td> <td>Elevators in Alterations</td> </tr> <tr> <td>4.31.9</td> <td>Text Telephones</td> </tr> <tr> <td>7.2</td> <td>Sales and Service Counters, Teller Windows, Information Counters</td> </tr> <tr> <td>9.1.4</td> <td>Classes of Sleeping Accommodations</td> </tr> <tr> <td>9.2.2(6)(d)</td> <td>Requirements for Accessible Units, Sleeping Rooms, and Suites</td> </tr> </table> <p><b>A3.0 Miscellaneous Instructions and Definitions.</b></p> <p><b>A3.5 Definitions.</b></p> <p><b>Transient Lodging.</b> The Department of Justice's policy and rules further define what is covered as transient lodging.</p> <p><b>A4.0 Accessible Elements and Spaces: Scope and Technical Requirements.</b></p> <p><b>A4.1.1 Application.</b></p> <p><b>A4.1.1(3) Areas Used Only by Employees as Work Areas.</b> Where there are a series of individual work stations of the same type (e.g., laboratories, service counters, ticket booths), 5%, but not less</p>	4.1.6(3)(c)	Elevators in Alterations	4.31.9	Text Telephones	7.2	Sales and Service Counters, Teller Windows, Information Counters	9.1.4	Classes of Sleeping Accommodations	9.2.2(6)(d)	Requirements for Accessible Units, Sleeping Rooms, and Suites	<p>than one, of each type of work station should be constructed so that an individual with disabilities can maneuver within the work stations. Rooms housing individual offices in a typical office building must meet the requirements of the guidelines concerning doors, accessible routes, etc. but do not need to allow for maneuvering space around individual desks. Modifications required to permit maneuvering within the work area may be accomplished as a reasonable accommodation to individual employees with disabilities under Title I of the ADA. Consideration should also be given to placing shelves in employee work areas at a convenient height for accessibility or installing commercially available shelving that is adjustable so that reasonable accommodations can be made in the future.</p> <p>If work stations are made accessible they should comply with the applicable provisions of 4.2 through 4.35.</p> <p><b>A4.1.2 Accessible Sites and Exterior Facilities: New Construction.</b></p> <p><b>A4.1.2(2)(b) Court Sports:</b> The accessible route must be direct and connect both sides of the court without requiring players on one side of the court to traverse through or around another court to get to the other side of the court.</p> <p><b>A4.1.2(4) Exception 1.</b> An accessible route is required to connect to the boundary of the area of sport activity. The term "area of sport activity" distinguishes that portion of a room or space where the play or practice of a sport occurs from adjacent areas. Examples of areas of sport activity include: basketball courts, baseball fields, running tracks, bowling lanes, skating rinks, and the area surrounding a piece of gymnastic equipment. While the size of an area of sport activity may vary from sport to sport, each includes only the space needed to play. The following example is provided for additional clarification.</p> <p><i>Example.</i> Boundary lines define the field where a football game is played. A safety border is also provided around the field. The game may</p>
4.1.6(3)(c)	Elevators in Alterations										
4.31.9	Text Telephones										
7.2	Sales and Service Counters, Teller Windows, Information Counters										
9.1.4	Classes of Sleeping Accommodations										
9.2.2(6)(d)	Requirements for Accessible Units, Sleeping Rooms, and Suites										

**A4.1.3 Accessible Buildings: New Construction**

<p>temporarily be played in the space between the boundary lines and the safety border when players are pushed out of bounds or momentum carries them forward while receiving a pass. In the game of football, the space between the boundary line and the safety border is used to play the game. This space and the football field are included in the area of sport activity.</p> <p><b>A4.1.2(4) Exception 2.</b> Public circulation routes where animals may also travel, such as in petting zoos and passageways alongside animal pens in State fairs, are not eligible for the exception.</p> <p><b>A4.1.2(5)(e)</b> Valet parking is not always usable by individuals with disabilities. For instance, an individual may use a type of vehicle controls that render the regular controls inoperable or the driver's seat in a van may be removed. In these situations, another person cannot park the vehicle. It is recommended that some self-parking spaces be provided at valet parking facilities for individuals whose vehicles cannot be parked by another person and that such spaces be located on an accessible route to the entrance of the facility.</p> <p><b>A4.1.3 Accessible Buildings: New Construction.</b></p> <p><b>4.1.3(1)(b) Court Sports:</b> The accessible route must be direct and connect both sides of the court without requiring players on one side of the court to traverse through or around another court to get to the other side of the court.</p> <p><b>4.1.3(3) Exception 1.</b> An accessible route is required to connect to the boundary of the area of sport activity. The term "area of sport activity" distinguishes that portion of a room or space where the play or practice of a sport occurs from adjacent areas. Examples of areas of sport activity include: basketball courts, baseball fields, running tracks, bowling lanes, skating rinks, and the area surrounding a piece of fixed gymnastic equipment. While the size of an area of sport activity may vary from sport to sport, each includes only the space needed to play. The following example is provided for additional clarification.</p>	<p><i>Example.</i> Boundary lines define the field where a football game is played. A safety border is also provided around the field. The game may temporarily be played in the space between the boundary lines and the safety border when players are pushed out of bounds or momentum carries them forward while receiving a pass. In the game of football, the space between the boundary line and the safety border is used to play the game. This space and the football field are included in the area of sport activity.</p> <p><b>4.1.3(3) Exception 2.</b> Public circulation routes where animals may also travel, such as in petting zoos and passageways alongside animal pens in State fairs, are not eligible for the exception.</p> <p><b>A4.1.3(5)</b> Only passenger elevators are covered by the accessibility provisions of 4.10. Materials and equipment hoists, freight elevators not intended for passenger use, dumbwaiters, and construction elevators are not covered by these guidelines. If a building is exempt from the elevator requirement, it is not necessary to provide a platform lift or other means of vertical access in lieu of an elevator.</p> <p>Under Exception 4, platform lifts are allowed where existing conditions make it impractical to install a ramp or elevator. Such conditions generally occur where it is essential to provide access to small raised or lowered areas where space may not be available for a ramp. Examples include, but are not limited to, raised pharmacy platforms, commercial offices raised above a sales floor, or radio and news booths.</p> <p>While the use of platform lifts is allowed, ramps are recommended to provide access to player seating areas serving an area of sport activity.</p> <p><b>A4.1.3(9)</b> Supervised automatic sprinkler systems have built in signals for monitoring features of the system such as the opening and closing of water control valves, the power supplies for needed pumps, water tank levels, and for indicating conditions that will impair the satisfactory operation of the sprinkler system. Because of these monitoring features, supervised automatic sprinkler systems have a high level of</p>
--	--

A1A

**A4.1.3 Accessible Buildings: New Construction**

<p>satisfactory performance and response to fire conditions.</p> <p><b>A4.1.3(10)</b> If an odd number of drinking fountains is provided on a floor, the requirement in 4.1.3(10)(b) may be met by rounding down the odd number to an even number and calculating 50% of the even number. When more than one drinking fountain on a floor is required to comply with 4.15, those fountains should be dispersed to allow wheelchair users convenient access. For example, in a large facility such as a convention center that has water fountains at several locations on a floor, the accessible water fountains should be located so that wheelchair users do not have to travel a greater distance than other people to use a drinking fountain.</p> <p><b>A4.1.3(12)(c)</b> Different types of lockers may include full-size and half-size lockers, as well as those specifically designed for storage of various sports equipment.</p>	
---	--

A1B

**A4.2 Space Allowances and Reach Ranges**

**A4.1.3(17)(b)** In addition to the requirements of section 4.1.3(17)(b), the installation of additional volume controls is encouraged. Volume controls may be installed on any telephone.

**A4.1.3(19)(a)** Readily removable or folding seating units may be installed in lieu of providing an open space for wheelchair users. Folding seating units are usually two fixed seats that can be easily folded into a fixed center bar to allow for one or two open spaces for wheelchair users when necessary. These units are more easily adapted than removable seats which generally require the seat to be removed in advance by the facility management.

Either a sign or a marker placed on seating with removable or folding arm rests is required by this section. Consideration should be given for ensuring identification of such seats in a darkened theater. For example, a marker which contrasts (light on dark or dark on light) and which also reflects light could be placed on the side of such seating so as to be visible in a lighted auditorium and also to reflect light from a flashlight.

**A4.1.6 Accessible Buildings: Alterations.**

**A4.1.6(1)(h)** When an entrance is being altered, it is preferable that those entrances being altered be made accessible to the extent feasible.

**A4.1.7 Accessible Buildings: Historic Preservation**

**A4.1.7(1)** The Department of Justice's regulations implementing titles II and III of the ADA require alternative methods of access where compliance with the special access provisions in 4.1.7(3) would threaten or destroy the historic significance of a qualified historic facility. The requirement for public facilities subject to title II is provided at 28 CFR 35.154(b) and the requirement for private facilities subject to title III is provided at 28 CFR 36.405(b).

**A4.2 Space Allowances and Reach Ranges.**

**A4.2.1 Wheelchair Passage Width.**

(1) Space Requirements for Wheelchairs. Many persons who use wheelchairs need a 30 in (760 mm) clear opening width for doorways,

gates, and the like, when the latter are entered head-on. If the person is unfamiliar with a building, if competing traffic is heavy, if sudden or frequent movements are needed, or if the wheelchair must be turned at an opening, then greater clear widths are needed. For most situations, the addition of an inch of leeway on either side is sufficient. Thus, a minimum clear width of 32 in (815 mm) will provide adequate clearance. However, when an opening or a restriction in a passageway is more than 24 in (610 mm) long, it is essentially a passageway and must be at least 36 in (915 mm) wide.

(2) Space Requirements for Use of Walking Aids. Although people who use walking aids can maneuver through clear width openings of 32 in (815 mm), they need 36 in (915 mm) wide passageways and walks for comfortable gaits. Crutch tips, often extending down at a wide angle, are a hazard in narrow passageways where they might not be seen by other pedestrians. Thus, the 36 in (915 mm) width provides a safety allowance both for the person with a disability and for others.

(3) Space Requirements for Passing. Able-bodied persons in winter clothing, walking

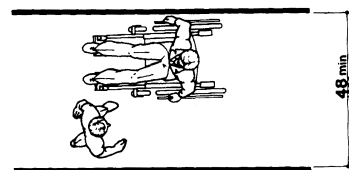

**Fig. A1**  
Minimum Passage Width for One Wheelchair and One Ambulatory Person

A4.2 Space Allowances and Reach Ranges

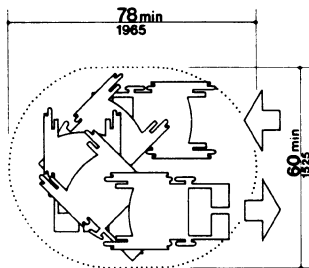
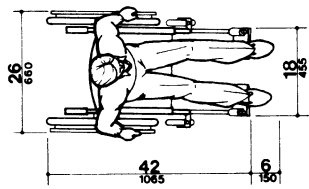
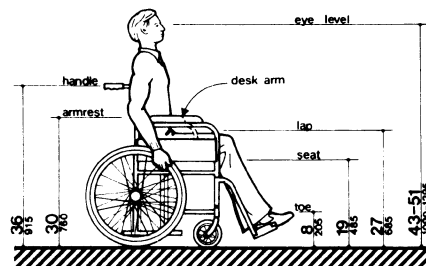

Fig. A2  
Space Needed for Smooth U-Turn in a Wheelchair

straight ahead with arms swinging, need 32 in (815 mm) of width, which includes 2 in (50 mm) on either side for sway, and another 1 in (25 mm) tolerance on either side for clearing nearby objects or other pedestrians. Almost all wheelchair users and those who use walking aids can also manage within this 32 in (815 mm) width for short distances. Thus, two streams of traffic can pass in 64 in (1625 mm) in a comfortable flow. Sixty inches (1525 mm) provides a minimum width for a somewhat more restricted flow. If the clear width is less than 60 in (1525 mm), two wheelchair users will not be able to pass but will have to seek a wider place for passing. Forty-eight inches (1220 mm) is the minimum width needed for an ambulatory person to pass a nonambulatory or semi-ambulatory person. Within this 48 in (1220 mm) width, the ambulatory person will have to twist to pass a wheelchair user, a person with a *service animal*, or a



NOTE: Footrests may extend further for tall people

Fig. A3  
Dimensions of Adult-Sized Wheelchairs

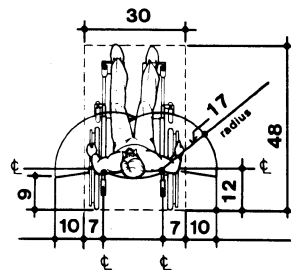
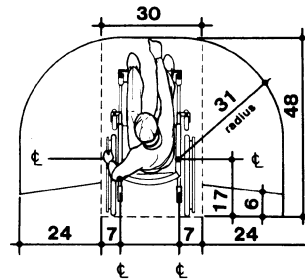

Fig. A3 (a)

A3

**A4.2.3 Wheelchair Turning Space**

semi-ambulatory person. There will be little leeway for swaying or missteps (see Fig. A1).

**A4.2.3 Wheelchair Turning Space.** *These guidelines specify a minimum space of 60 in (1525 mm) diameter or a 60 in by 60 in (1525 mm by 1525 mm) T-shaped space for a pivoting 180-degree turn of a wheelchair. This space is usually satisfactory for turning around, but many people will not be able to turn without repeated tries and bumping into surrounding objects. The space shown in Fig. A2 will allow most wheelchair users to complete U-turns without difficulty.*

**A4.2.4 Clear Floor or Ground Space for Wheelchairs.** The wheelchair and user shown in Fig. A3 represent typical dimensions for a large adult male. The space requirements in this guideline are based upon maneuvering clearances that will accommodate most wheelchairs. Fig. A3 provides a uniform reference for design not covered by this guideline.

**A4.2.5 & A4.2.6 Reach.** *Reach ranges for persons seated in wheelchairs may be further clarified in Fig. A3(a). These drawings approximate in the plan view the information shown in Fig. 4, 5, and 6.*

*The following table provides guidance on reach ranges for children according to age where building elements such as coat hooks, lockers, or controls and operating mechanisms are designed for use primarily by children. These dimensions apply to either forward or side reaches. Accessible elements, controls, and operating mechanisms designed for adult use or children over age 12 can be located outside these ranges but must be within the adult reach ranges required by 4.2.5 and 4.2.6.*

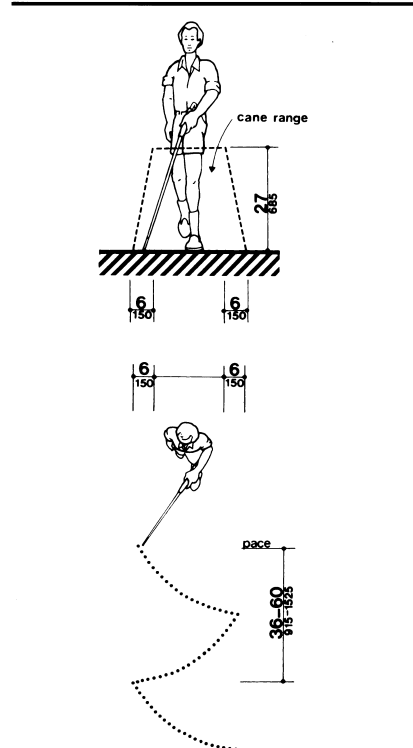

Fig A4  
Cane Technique

**Children's Reach Ranges**

Forward or Side Reach	Ages 3 and 4	Ages 5 through 8	Ages 9 through 12
High (maximum)	36 in (915 mm)	40 in (1015 mm)	44 in (1120 mm)
Low (minimum)	20 in (510 mm)	18 in (455 mm)	16 in (405 mm)

A4

**A4.3 Accessible Route**

<p><b>A4.3 Accessible Route.</b></p> <p><b>A4.3.1 General.</b></p> <p>(1) Travel Distances. Many people with mobility impairments can move at only very slow speeds; for many, traveling 200 ft (61 m) could take about 2 minutes. This assumes a rate of about 1.5 ft/s (455 mm/s) on level ground. It also assumes that the traveler would move continuously. However, on trips over 100 ft (30 m), disabled people are apt to rest frequently, which substantially increases their trip times. Resting periods of 2 minutes for every 100 ft (30 m) can be used to estimate travel times for people with severely limited stamina. In inclement weather, slow progress and resting can greatly increase a disabled person's exposure to the elements.</p> <p>(2) Sites. Level, indirect routes or those with running slopes lower than 1:20 can sometimes provide more convenience than direct routes with maximum allowable slopes or with ramps.</p> <p><b>A4.3.10 Egress.</b> Because people with disabilities may visit, be employed or be a resident in any building, emergency management plans with specific provisions to ensure their safe evacuation also play an essential role in fire safety and life safety.</p> <p><b>A4.3.11.3 Stairway Width.</b> A 48 in (1220 mm) wide exit stairway is needed to allow assisted evacuation (e.g., carrying a person in a wheelchair) without encroaching on the exit path for ambulatory persons.</p>	
--	--

A4A

**A4.5 Ground and Floor Surfaces**

**A4.3.11.4 Two-way Communication.** *It is essential that emergency communication not be dependent on voice communications alone because the safety of people with hearing or speech impairments could be jeopardized. The visible signal requirement could be satisfied with something as simple as a button in the area of rescue assistance that lights, indicating that help is on the way, when the message is answered at the point of entry.*

**A4.4 Protruding Objects.**

**A4.4.1 General.** *Service animals are trained to recognize and avoid hazards. However, most people with severe impairments of vision use the long cane as an aid to mobility. The two principal cane techniques are the touch technique, where the cane arcs from side to side and touches points outside both shoulders; and the diagonal technique, where the cane is held in a stationary position diagonally across the body with the cane tip touching or just above the ground at a point outside one shoulder and the handle or grip extending to a point outside the other shoulder. The touch technique is used primarily in uncontrolled areas, while the diagonal technique is used primarily in certain limited, controlled, and familiar environments. Cane users are often trained to use both techniques.*

Potential hazardous objects are noticed only if they fall within the detection range of canes (see Fig. A4). Visually impaired people walking toward an object can detect an overhang if its lowest surface is not higher than 27 in (685 mm). When walking alongside protruding objects, they cannot detect overhangs. Since proper cane and service animal techniques keep people away from the edge of a path or from walls, a slight overhang of no more than 4 in (100 mm) is not hazardous.

**A4.5 Ground and Floor Surfaces.**

**A4.5.1 General.** *People who have difficulty walking or maintaining balance or who use crutches, canes, or walkers, and those with restricted gaits are particularly sensitive to slipping and tripping hazards. For such people, a stable and regular surface is necessary for safe walking, particularly on stairs. Wheelchairs can be propelled most easily on surfaces that are hard, stable, and regular. Soft loose*

*surfaces such as shag carpet, loose sand or gravel, wet clay, and irregular surfaces such as cobblestones can significantly impede wheelchair movement.*

*Slip resistance is based on the frictional force necessary to keep a shoe heel or crutch tip from slipping on a walking surface under conditions likely to be found on the surface. While the dynamic coefficient of friction during walking varies in a complex and non-uniform way, the static coefficient of friction, which can be measured in several ways, provides a close approximation of the slip resistance of a surface. Contrary to popular belief, some slippage is necessary to walking, especially for persons with restricted gaits; a truly "non-slip" surface could not be negotiated.*

*The Occupational Safety and Health Administration recommends that walking surfaces have a static coefficient of friction of 0.5. A research project sponsored by the Architectural and Transportation Barriers Compliance Board (Access Board) conducted tests with persons with disabilities and concluded that a higher coefficient of friction was needed by such persons. A static coefficient of friction of 0.6 is recommended for accessible routes and 0.8 for ramps.*

*It is recognized that the coefficient of friction varies considerably due to the presence of contaminants, water, floor finishes, and other factors not under the control of the designer or builder and not subject to design and construction guidelines and that compliance would be difficult to measure on the building site. Nevertheless, many common building materials suitable for flooring are now labeled with information on the static coefficient of friction. While it may not be possible to compare one product directly with another, or to guarantee a constant measure, builders and designers are encouraged to specify materials with appropriate values. As more products include information on slip resistance, improved uniformity in measurement and specification is likely. The Access Board's advisory guidelines on Slip Resistant Surfaces provides additional information on this subject.*

*Cross slopes on walks and ground or floor surfaces can cause considerable difficulty in propelling a wheelchair in a straight line.*

A5



**A4.6 Parking and Passenger Loading Zones**

**A4.5.3 Carpet.** Much more needs to be done in developing both quantitative and qualitative criteria for carpeting (*i.e.*, problems associated with texture and weave need to be studied). However, certain functional characteristics are well established. When both carpet and padding are used, it is desirable to have minimum movement (preferably none) between the floor and the pad and the pad and the carpet which would allow the carpet to hump or warp. In heavily trafficked areas, a thick, soft (plush) pad or cushion, particularly in combination with long carpet pile, makes it difficult for individuals in wheelchairs and those with other ambulatory disabilities to get about. Firm carpeting can be achieved through proper selection and combination of pad and carpet, sometimes with the elimination of the pad or cushion, and with proper installation. *Carpeting designed with a weave that causes a zig-zag effect when wheeled across is strongly discouraged.*

**A4.6 Parking and Passenger Loading Zones.**

**A4.6.3 Parking Spaces.** *The increasing use of vans with side-mounted lifts or ramps by persons with disabilities has necessitated some revisions in specifications for parking spaces and adjacent access aisles. The typical accessible parking space is 96 in (2440 mm) wide with an adjacent 60 in (1525 mm) access aisle. However, this aisle does not permit lifts or ramps to be deployed and still leave room for a person using a wheelchair or other mobility aid to exit the lift platform or ramp. In tests conducted with actual lift/van/wheelchair combinations, (under a Board-sponsored Accessible Parking and Loading Zones Project) researchers found that a space and aisle totaling almost 204 in (5180 mm) wide was needed to deploy a lift and exit conveniently. The "van accessible" parking space required by these guidelines provides a 96 in (2440 mm) wide space with a 96 in (2440 mm) adjacent access aisle which is just wide enough to maneuver and exit from a side mounted lift. If a 96 in (2440 mm) access aisle is placed between two spaces, two "van accessible" spaces are created. Alternatively, if the wide access aisle is provided at the end of a row (an area often unused), it may be possible to provide the wide access aisle without additional space (see Fig. A5(a)).*

*A sign is needed to alert van users to the presence of the wider aisle, but the space is not intended to be restricted only to vans.*

*"Universal" Parking Space Design. An alternative to the provision of a percentage of spaces with a wide aisle, and the associated need to include additional signage, is the use of what has been called the "universal" parking space design. Under this design, all accessible spaces are 132 in (3350 mm) wide with a 60 in (1525 mm) access aisle (see Fig. A5(b)). One*

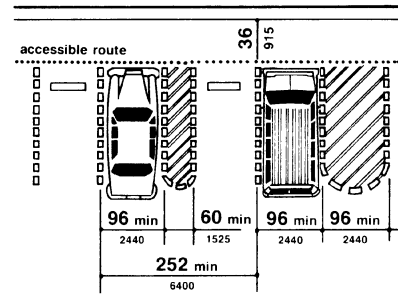

(a) Van Accessible Space at End Row

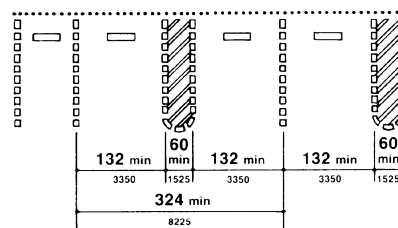

(b) Universal Parking Space Design

Fig. A5  
Parking Space Alternatives

A6

## A4.8 Ramps

*advantage to this design is that no additional signage is needed because all spaces can accommodate a van with a side-mounted lift or ramp. Also, there is no competition between cars and vans for spaces since all spaces can accommodate either. Furthermore, the wider space permits vehicles to park to one side or the other within the 132 in (3350 mm) space to allow persons to exit and enter the vehicle on either the driver or passenger side, although, in some cases, this would require exiting or entering without a marked access aisle.*

*An essential consideration for any design is having the access aisle level with the parking space. Since a person with a disability, using a lift or ramp, must maneuver within the access aisle, the aisle cannot include a ramp or sloped area. The access aisle must be connected to an accessible route to the appropriate accessible entrance of a building or facility. The parking access aisle must either blend with the accessible route or have a curb ramp complying with 4.7. Such a curb ramp opening must be located within the access aisle boundaries, not within the parking space boundaries. Unfortunately, many facilities are designed with a ramp that is blocked when any vehicle parks in the accessible space. Also, the required dimensions of the access aisle cannot be restricted by planters, curbs or wheel stops.*

**A4.6.4 Signage.** Signs designating parking places for disabled people can be seen from a driver's seat if the signs are mounted high enough above the ground and located at the front of a parking space.

**A4.6.5 Vertical Clearance.** High-top vans, which disabled people or transportation services often use, require higher clearances in parking garages than automobiles.

#### **A4.8 Ramps.**

**A4.8.1 General.** Ramps are essential for wheelchair users if elevators or lifts are not available to connect different levels. However, some people who use walking aids have difficulty with ramps and prefer stairs.

**A4.8.2 Slope and Rise.** *Ramp slopes between 1:16 and 1:20 are preferred.* The ability to manage an incline is related to both its slope and its length. Wheelchair users with disabilities affecting their arms or with low stamina have serious difficulty using inclines. Most ambulatory people and most people who use wheelchairs can manage a slope of 1:16. Many people

cannot manage a slope of 1:12 for 30 ft (9 m).

**A4.8.4 Landings.** *Level landings are essential toward maintaining an aggregate slope that complies with these guidelines. A ramp landing that is not level causes individuals using wheelchairs to tip backward or bottom out when the ramp is approached.*

**A4.8.5 Handrails.** The requirements for stair and ramp handrails in this *guideline* are for adults. When children are principal users in a building or facility (e.g. elementary schools), a second set of handrails at an appropriate height can assist them and aid in preventing accidents. *A maximum height of 28 inches measured to the top of the gripping surface from the ramp surface or stair nosing is recommended for handrails designed for children. Sufficient vertical clearance between upper and lower handrails (9 inches minimum) should be provided to help prevent entrapment.*

#### **A4.9 Stairs.**

**A4.9.1 Minimum Number.** *Only interior and exterior stairs connecting levels that are not connected by an elevator, ramp, or other accessible means of vertical access have to comply with 4.9.*

**A4.9.5 Handrails.** *See A4.8.5.*

#### **A4.10 Elevators.**

**A4.10.6 Door Protective and Reopening Device.** The required door reopening device would hold the door open for 20 seconds if the doorway remains obstructed. After 20 seconds, the door may begin to close. However, if designed in accordance with ASME A17.1-1990, the door closing movement could still be stopped if a person or object exerts sufficient force at any point on the door edge.

**A4.10.7 Door and Signal Timing for Hall Calls.** This paragraph allows variation in the location of call buttons, advance time for warning signals, and the door-holding period used to meet the time requirement.

**A4.10.12 Car Controls.** Industry-wide standardization of elevator control panel design would make all elevators significantly more convenient for use by people with severe visual impairments. In many cases, it will be possible to locate the highest control on elevator panels within 48 in (1220 mm) from the floor.

A7

**A4.11 Platform Lifts (Wheelchair Lifts)**

<p><b>A4.10.13 Car Position Indicators.</b> A special button may be provided that would activate the audible signal within the given elevator only for the desired trip, rather than maintaining the audible signal in constant operation.</p> <p><b>A4.10.14 Emergency Communications.</b> A device that requires no handset is easier to use by people who have difficulty reaching. Also, small handles on handset compartment doors are not usable by people who have difficulty grasping.</p> <p><i>Ideally, emergency two-way communication systems should provide both voice and visual display intercommunication so that persons with hearing impairments and persons with vision impairments can receive information regarding the status of a rescue. A voice intercommunication system cannot be the only means of communication because it is not accessible to people with speech and hearing impairments. While a voice intercommunication system is not required, at a minimum, the system should provide both an audio and visual indication that a rescue is on the way.</i></p> <p><b>A4.11 Platform Lifts (Wheelchair Lifts).</b></p> <p><b>A4.11.2 Other Requirements.</b> Inclined stairway chairlifts, and inclined and vertical platform lifts (wheelchair lifts) are available for short-distance, vertical transportation of people with disabilities. Care should be taken in selecting lifts as some lifts are not equally suitable for use by both wheelchair users and semi-ambulatory individuals.</p> <p><b>A4.12 Windows.</b></p> <p><b>A4.12.1 General.</b> Windows intended to be operated by occupants in accessible spaces should comply with 4.12.</p> <p><b>A4.12.2 Window Hardware.</b> Windows requiring pushing, pulling, or lifting to open (for example, double-hung, sliding, or casement and awning units without cranks) should require no more than 5 lbf (22.2 N) to open or close. Locks, cranks, and other window hardware should comply with 4.27.</p>	<p><b>A4.13 Doors.</b></p> <p><b>A4.13.8 Thresholds at Doorways.</b> Thresholds and surface height changes in doorways are particularly inconvenient for wheelchair users who also have low stamina or restrictions in arm movement because complex maneuvering is required to get over the level change while operating the door.</p> <p><b>A4.13.9 Door Hardware.</b> Some disabled persons must push against a door with their chair or walker to open it. Applied kickplates on doors with closers can reduce required maintenance by withstanding abuse from wheelchairs and canes. To be effective, they should cover the door width, less approximately 2 in (51 mm), up to a height of 16 in (405 mm) from its bottom edge and be centered across the width of the door.</p> <p><b>A4.13.10 Door Closers.</b> Closers with delayed action features give a person more time to maneuver through doorways. They are particularly useful on frequently used interior doors such as entrances to toilet rooms.</p> <p><b>A4.13.11 Door Opening Force.</b> Although most people with disabilities can exert at least 5 lbf (22.2N), both pushing and pulling from a stationary position, a few people with severe disabilities cannot exert 3 lbf (13.13N). Although some people cannot manage the allowable forces in this guideline and many others have difficulty, door closers must have certain minimum closing forces to close doors satisfactorily. Forces for pushing or pulling doors open are measured with a push-pull scale under the following conditions:</p> <ul style="list-style-type: none"> <li>(1) Hinged doors: Force applied perpendicular to the door at the door opener or 30 in (760 mm) from the hinged side, whichever is farther from the hinge.</li> <li>(2) Sliding or folding doors: Force applied parallel to the door at the door pull or latch.</li> <li>(3) Application of force: Apply force gradually so that the applied force does not exceed the resistance of the door. In high-rise buildings, air-pressure differentials may require a modification of this specification in order to meet the functional intent.</li> </ul>
--	---

A8

**A4.15 Drinking Fountains and Water Coolers**

**A4.13.12 Automatic Doors and Power-Assisted Doors.** Sliding automatic doors do not need guard rails and are more convenient for wheelchair users and visually impaired people to use. If slowly opening automatic doors can be reactivated before their closing cycle is completed, they will be more convenient in busy doorways.

**A4.15 Drinking Fountains and Water Coolers.**

**A4.15.2 Spout Height.** Two drinking fountains, mounted side by side or on a single post, are usable by people with disabilities and people who find it difficult to bend over.

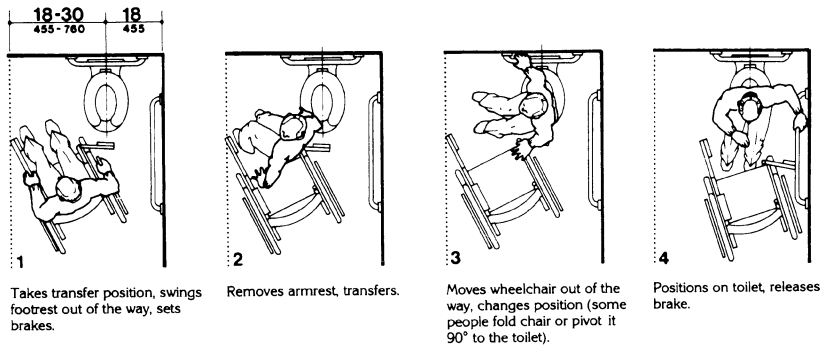

(a) Diagonal Approach

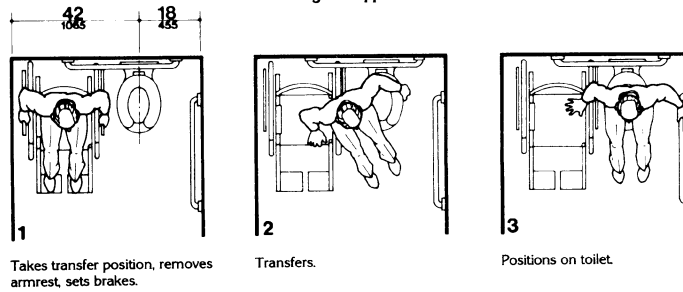

(b) Side Approach

**Fig. A6**  
**Wheelchair Transfers**

A9

**A4.16 Water Closets**

**A4.16 Water Closets.**

**A4.16.3 Height.** Height preferences for toilet seats vary considerably among disabled people. Higher seat heights may be an advantage to some ambulatory disabled people, but are often a disadvantage for wheelchair users and others. Toilet seats 18 in (455 mm) high seem to be a reasonable compromise. Thick seats and filler rings are available to adapt standard fixtures to these requirements.

**A4.16.4 Grab Bars.** Fig. A6(a) and (b) show the diagonal and side approaches most commonly used to transfer from a wheelchair to a water closet. Some wheelchair users can transfer from the front of the toilet while others use a 90-degree approach. Most people who use the two additional approaches can also use either the diagonal approach or the side approach.

**A4.16.5 Flush Controls.** Flush valves and related plumbing can be located behind walls or to the side of the toilet, or a toilet seat lid can be provided if plumbing fittings are directly behind the toilet seat. Such designs reduce the chance of injury and imbalance caused by leaning back against the fittings. Flush controls for tank-type toilets have a standardized mounting location on the left side of the tank (facing the tank). Tanks can be obtained by special order with controls mounted on the right side. If administrative authorities require flush controls for flush valves to be located in a position that conflicts

with the location of the rear grab bar, then that bar may be split or shifted toward the wide side of the toilet area.

**A4.16.7 Water Closets for Children.**

*The requirements in 4.16.7 are to be followed where the exception for children's water closets in 4.16.1 is utilized. Use of this exception is optional since these guidelines do not require water closets or other building elements to be designed according to children's dimensions. The following table provides additional guidance in applying the specifications for water closets for children according to the age group served and reflects the differences in the size, stature, and reach ranges of children 3 through 12. The specifications chosen should correspond to the age of the primary user group. The specifications of one age group should be applied consistently in the installation of a water closet and related elements.*

**A4.17 Toilet Stalls.**

**A4.17.3 Size and Arrangement.** *This section requires use of the 60 in (1525 mm) standard stall (Figure 30(a)) and permits the 36 in (915 mm) or 48 in (1220 mm) wide alternate stall (Figure 30(b)) only in alterations where provision of the standard stall is technically infeasible or where local plumbing codes prohibit reduction in the number of fixtures. A standard stall provides a clear space on one side of the water closet to enable persons who use wheelchairs to perform a side or diagonal transfer from the wheelchair to the water*

**Specifications for Water Closets Serving Children Ages 3 through 12**

	Ages 3 and 4	Ages 5 through 8	Ages 9 through 12
(1) Water Closet Centerline	12 in (305 mm)	12 to 15 in (305 to 380 mm)	15 to 18 in (380 to 455 mm)
(2) Toilet Seat Height	11 to 12 in (280 to 305 mm)	12 to 15 in (305 to 380 mm)	15 to 17 in (380 to 430 mm)
(3) Grab Bar Height	18 to 20 in (455 to 510 mm)	20 to 25 in (510 to 635 mm)	25 to 27 in (635 to 685 mm)
(4) Dispenser Height	14 in (355 mm)	14 to 17 in (355 to 430 mm)	17 to 19 in (430 to 485 mm)

A10

**A4.17 Toilet Stalls**

closet. However, some persons with disabilities who use mobility aids such as walkers, canes or crutches are better able to use the two parallel grab bars in the 36 in (915 mm) wide alternate stall to achieve a standing position.

In large toilet rooms, where six or more toilet stalls are provided, it is therefore required that a 36 in (915 mm) wide stall with parallel grab bars be provided in addition to the standard stall required in new construction. The 36 in (915 mm) width is necessary to achieve proper use of the grab bars; wider stalls would position the grab bars too far apart to be easily used and narrower stalls would position the grab bars too close to the water closet. Since the stall is primarily intended for use by persons using canes, crutches and walkers, rather than wheelchairs, the length of the stall could be conventional. The door, however, must swing outward to ensure a usable space for people who use crutches or walkers.

**A4.17.5 Doors.** To make it easier for wheelchair users to close toilet stall doors, doors can be provided with closers, spring hinges, or a pull bar mounted on the inside surface of the door near the hinge side.

**A4.17.7 Toilet Stalls for Children.** See A4.16.7.

**A4.19 Lavatories and Mirrors.**

**A4.19.6 Mirrors.** If mirrors are to be used by both ambulatory people and wheelchair users, then they must be at least 74 in (1880 mm) high at their topmost edge. A single full length mirror can accommodate all people, including children. Clear floor space for a forward approach 30 by 48 inches (760 mm by 1220 mm) should be provided in front of full length mirrors. Doors should not swing into this clear floor space. Mirrors provided above lavatories designed for children should be mounted with the bottom edge of the reflecting surface no higher than 34 inches (865 mm) above the finish floor or at the lowest mounting height permitted by fixtures and related elements.

**A4.21 Shower Stalls.**

**A4.21.1 General.** Shower stalls that are 36 in by 36 in (915 mm by 915 mm) wide provide additional safety to people who have difficulty maintaining balance because all grab bars and walls are within easy reach. Seated people use

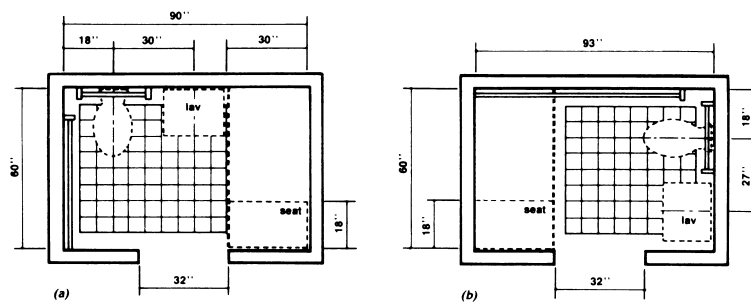

Fig. A7

**A4.23 Bathrooms, Bathing Facilities, and Shower Rooms**

the walls of 36 in by 36 in (915 mm by 915 mm) showers for back support. Shower stalls that are 60 in (1525 mm) wide and have no curb may increase usability of a bathroom by wheelchair users because the shower area provides additional maneuvering space.

**A4.22 Toilet Rooms.**

**A4.22.3 Clear Floor Space.** *In many small facilities, single-user restrooms may be the only facilities provided for all building users. In addition, the guidelines allow the use of "unisex" or "family" accessible toilet rooms in alterations when technical infeasibility can be demonstrated. Experience has shown that the provision of accessible "unisex" or single-user restrooms is a reasonable way to provide access for wheelchair users and any attendants, especially when attendants are of the opposite sex. Since these facilities have proven so useful, it is often considered advantageous to install a "unisex" toilet room in new facilities in addition to making the multi-stall restrooms accessible, especially in shopping malls, large auditoriums, and convention centers.*

*Figure 28 (section 4.16) provides minimum clear floor space dimensions for toilets in accessible "unisex" toilet rooms. The dotted lines designate the minimum clear floor space, depending on the direction of approach, required for wheelchair users to transfer onto the water closet. The dimensions of 48 in (1220 mm) and 60 in (1525 mm), respectively, correspond to the space required for the two common transfer approaches utilized by wheelchair users (see Fig. A6). It is important to keep in mind that the placement of the lavatory to the immediate side of the water closet will preclude the side approach transfer illustrated in Figure A6(b). To accommodate the side transfer, the space adjacent to the water closet must remain clear of obstruction for 42 in (1065 mm) from the centerline of the toilet (Figure 28) and the lavatory must not be located within this clear space. A turning circle or T-turn, the clear floor space at the lavatory, and maneuvering space at the door must be considered when determining the possible wall locations. A privacy latch or other accessible means of ensuring privacy during use should be provided at the door.*

**RECOMMENDATIONS:**

*1. In new construction, accessible single-user restrooms may be desirable in some situations because they can accommodate a wide variety*

*of building users. However, they cannot be used in lieu of making the multi-stall toilet rooms accessible as required.*

*2. Where strict compliance to the guidelines for accessible toilet facilities is technically infeasible in the alteration of existing facilities, accessible "unisex" toilets are a reasonable alternative.*

*3. In designing accessible single-user restrooms, the provisions of adequate space to allow a side transfer will provide accommodation to the largest number of wheelchair users.*

**A4.23 Bathrooms, Bathing Facilities, and Shower Rooms.**

**A4.23.3 Clear Floor Space.** *Figure A7 shows two possible configurations of a toilet room with a roll-in shower. The specific shower shown is designed to fit exactly within the dimensions of a standard bathtub. Since the shower does not have a lip, the floor space can be used for required maneuvering space. This would permit a toilet room to be smaller than would be permitted with a bathtub and still provide enough floor space to be considered accessible. This design can provide accessibility in facilities where space is at a premium (i.e., hotels and medical care facilities). The alternate roll-in shower (Fig. 57b) also provides sufficient room for the "T-turn" and does not require plumbing to be on more than one wall.*

**A4.23.9 Medicine Cabinets.** *Other alternatives for storing medical and personal care items are very useful to disabled people. Shelves, drawers, and floor-mounted cabinets can be provided within the reach ranges of disabled people.*

**A4.25.3 Height.** *For guidance on children's reach ranges, see A4.2.5 & 4.2.6.*

**A4.26 Handrails, Grab Bars, and Tub and Shower Seats.**

**A4.26.1 General.** *Many disabled people rely heavily upon grab bars and handrails to maintain balance and prevent serious falls. Many people brace their forearms between supports and walls to give them more leverage and stability in maintaining balance or for lifting. The grab bar clearance of 1-1/2 in (38 mm) required in this guideline is a safety*

**A4.27 Controls and Operating Mechanisms**

clearance to prevent injuries resulting from arms slipping through the openings. It also provides adequate gripping room.

**A4.26.2 Size and Spacing of Grab Bars and Handrails.** This specification allows for alternate shapes of handrails as long as they allow an opposing grip similar to that provided by a circular section of 1-1/4 in to 1-1/2 in (32 mm to 38 mm).

**A4.27 Controls and Operating Mechanisms.**

**A4.27.3 Height.** Fig. A8 further illustrates mandatory and advisory control mounting height provisions for typical equipment.

Electrical receptacles installed to serve individual appliances and not intended for regular or frequent use by building occupants are not required to be mounted within the specified reach ranges. Examples would be receptacles installed specifically for wall-mounted clocks, refrigerators, and microwave ovens. For guidance on children's reach ranges, see A4.2.5 & 4.2.6.

**A4.28 Alarms.**

**A4.28.2 Audible Alarms.** Audible emergency signals must have an intensity and frequency that can attract the attention of individuals who have partial hearing loss. People over 60 years of age generally have difficulty perceiving frequencies higher than 10,000 Hz. An alarm signal which has a periodic element to its signal, such as single stroke bells (clang-pause- clang-pause), hi-low (up-down-up-down) and fast whoop (on-off-on-off) are best. Avoid continuous or reverberating tones. Select a signal which has a sound characterized by three or four clear tones without a great deal of "noise" in between.

**A4.28.3 Visual Alarms.** The specifications in this section do not preclude the use of zoned or coded alarm systems.

**A4.28.4 Auxiliary Alarms.** Locating visual emergency alarms in rooms where persons who are deaf may work or reside alone can ensure that they will always be warned when an emergency alarm is activated. To be effective, such devices must be located and oriented

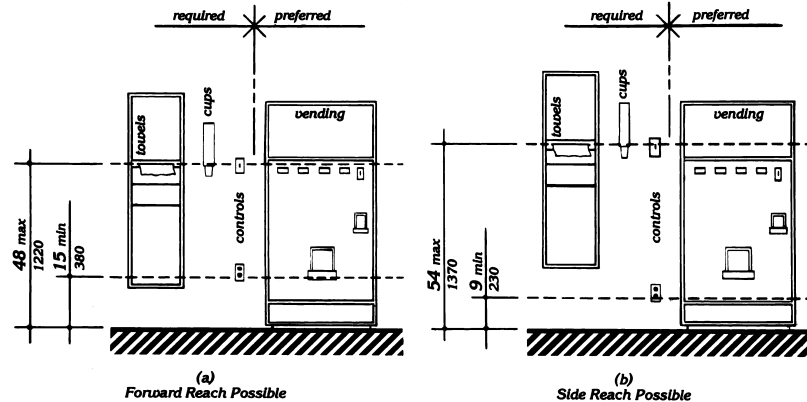

Fig. A8  
Control Reach Limitations



**A4.29 Detectable Warnings**

so that they will spread signals and reflections throughout a space or raise the overall light level sharply. *However, visual alarms alone are not necessarily the best means to alert sleepers. A study conducted by Underwriters Laboratory (UL) concluded that a flashing light more than seven times brighter was required (110 candela v. 15 candela, at the same distance) to awaken sleepers as was needed to alert awake subjects in a normal daytime illuminated room.*

*For hotel and other rooms where people are likely to be asleep, a signal-activated vibrator placed between mattress and box spring or under a pillow was found by UL to be much more effective in alerting sleepers. Many readily available devices are sound-activated so that they could respond to an alarm clock, clock radio, wake-up telephone call or room smoke detector. Activation by a building alarm system can either be accomplished by a separate circuit activating an auditory alarm which would, in turn, trigger the vibrator or by a signal transmitted through the ordinary 110-volt outlet. Transmission of signals through the power line is relatively simple and is the basis of common, inexpensive remote light control systems sold in many department and electronic stores for home use. So-called "wireless" intercoms operate on the same principal.*

**A4.29 Detectable Warnings.**

**A4.29.2 Detectable Warnings on Walk-  
ing Surfaces.** *The material used to provide contrast should contrast by at least 70%. Contrast in percent is determined by:*

$$\text{Contrast} = [(B_1 - B_2) / B_2] \times 100$$

*where B<sub>1</sub> = light reflectance value (LRV) of the lighter area and B<sub>2</sub> = light reflectance value (LRV) of the darker area.*

*Note that in any application both white and black are never absolute; thus, B<sub>1</sub> never equals 100 and B<sub>2</sub> is always greater than 0.*

**A4.30 Signage.**

**A4.30.1 General.** In building complexes where finding locations independently on a routine basis may be a necessity (for example, college campuses), tactile maps or prerecorded instructions can be very helpful to visually impaired people. Several maps and auditory

instructions have been developed and tested for specific applications. The type of map or instructions used must be based on the information to be communicated, which depends highly on the type of buildings or users.

Landmarks that can easily be distinguished by visually impaired individuals are useful as orientation cues. Such cues include changes in illumination level, bright colors, unique patterns, wall murals, location of special equipment or other architectural features.

Many people with disabilities have limitations in movement of their heads and reduced peripheral vision. Thus, signage positioned perpendicular to the path of travel is easiest for them to notice. People can generally distinguish signage within an angle of 30 degrees to either side of the centerlines of their faces without moving their heads.

**A4.30.2 Character Proportion.** The legibility of printed characters is a function of the viewing distance, character height, the ratio of the stroke width to the height of the character, the contrast of color between character and background, and print font. The size of characters must be based upon the intended viewing distance. A severely nearsighted person may have to be much closer to recognize a character of a given size than a person with normal visual acuity.

**A4.30.4 Raised and Brailled Characters and Pictorial Symbol Signs (Pictograms).** *The standard dimensions for literary Braille are as follows:*

<i>Dot diameter</i>	<i>.059 in.</i>
<i>Inter-dot spacing</i>	<i>.090 in.</i>
<i>Horizontal separation between cells</i>	<i>.241 in.</i>
<i>Vertical separation between cells</i>	<i>.395 in.</i>

Raised borders around signs containing raised characters may make them confusing to read unless the border is set far away from the characters. *Accessible signage with descriptive materials about public buildings, monuments, and objects of cultural interest may not provide sufficiently detailed and meaningful informa-*

**A4.30.5 Finish and Contrast**

<p>tion. Interpretive guides, audio tape devices, or other methods may be more effective in presenting such information.</p> <p><b>A4.30.5 Finish and Contrast.</b> An eggshell finish (11 to 19 degree gloss on 60 degree glossimeter) is recommended. Research indicates that signs are more legible for persons with low vision when characters contrast with their background by at least 70 percent. Contrast in percent shall be determined by:</p> $\text{Contrast} = [(B_1 - B_2) / B_1] \times 100$ <p>where <math>B_1</math> = light reflectance value (LRV) of the lighter area and <math>B_2</math> = light reflectance value (LRV) of the darker area.</p> <p>Note that in any application both white and black are never absolute; thus, <math>B_1</math> never equals 100 and <math>B_2</math> is always greater than 0.</p> <p>The greatest readability is usually achieved through the use of light-colored characters or symbols on a dark background.</p> <p><b>A4.30.7 Symbols of Accessibility for Different Types of Listening Systems.</b> Paragraph 4 of this section requires signage indicating the availability of an assistive listening system. An appropriate message should be displayed with the international symbol of access for hearing loss since this symbol conveys general accessibility for people with hearing loss. Some suggestions are:</p> <p style="text-align: center;">INFRARED ASSISTIVE LISTENING SYSTEM AVAILABLE —PLEASE ASK—</p> <p style="text-align: center;">AUDIO LOOP IN USE TURN T-SWITCH FOR BETTER HEARING —OR ASK FOR HELP—</p> <p style="text-align: center;">FM ASSISTIVE LISTENING SYSTEM AVAILABLE —PLEASE ASK—</p> <p>The symbol may be used to notify persons of the availability of other auxiliary aids and services such as: real time captioning, captioned note taking, sign language interpreters, and oral interpreters.</p>	<p><b>A4.30.8 Illumination Levels.</b> Illumination levels on the sign surface shall be in the 100 to 300 lux range (10 to 30 footcandles) and shall be uniform over the sign surface. Signs shall be located such that the illumination level on the surface of the sign is not significantly exceeded by the ambient light or visible bright lighting source behind or in front of the sign.</p>
--	--

A14A

**A4.31 Telephones**

**A4.31 Telephones.**

**A4.31.3 Mounting Height.** In localities where the dial-tone first system is in operation, calls can be placed at a coin telephone through the operator without inserting coins. The operator button is located at a height of 46 in (1170 mm) if the coin slot of the telephone is at 54 in (1370 mm). A generally available public telephone with a coin slot mounted lower on the equipment would allow universal installation of telephones at a height of 48 in (1220 mm) or less to all operable parts.

**A4.31.9(1)** *A public text telephone (TTY) may be an integrated text telephone (TTY) pay telephone unit or a conventional portable text telephone (TTY) that is permanently affixed within, or adjacent to, the telephone enclosure. In order to be usable with a pay telephone, a text telephone (TTY) which is not a single integrated text telephone (TTY) pay telephone unit will require a shelf large enough (10 in (255 mm) wide by 10 in (255 mm) deep with a 6 in (150 mm) vertical clearance minimum) to accommodate the device, an electrical outlet, and a power cord.*

**A4.31.9(3)** *Movable or portable text telephones (TTYs) may be used to provide equivalent facilitation. A text telephone (TTY) should be readily available so that a person using it may access the text telephone (TTY) easily and conveniently. As currently designed, pocket-type text telephones (TTYs) for personal use do not accommodate a wide range of users. Such devices would not be considered substantially equivalent to conventional text telephones (TTYs). However, in the future as technology develops this could change.*

**A4.32 Fixed or Built-in Seating and Tables.**

**A4.32.4 Height of Tables or Counters.** Different types of work require different table or counter heights for comfort and optimal performance. Light detailed work such as writing requires a table or counter close to elbow height for a standing person. Heavy manual work such as rolling dough requires a counter or table height about 10 in (255 mm) below elbow height for a standing person. This principle of high/low table or counter heights also applies for seated persons; however, the limiting condition for seated manual work is clearance under the table or counter.

Table A1 shows convenient counter heights for seated persons. The great variety of heights for comfort and optimal performance indicates a need for alternatives or a compromise in height if people who stand and people who sit will be using the same counter area.

**Table A1  
Convenient Heights of Tables  
and Counters for Seated People<sup>1</sup>**

Conditions of Use	Short Women in mm	Tall Men in mm
Seated in a wheelchair:		
Manual work—		
Desk or removable armrests	26 660	30 760
Fixed, full-size armrests <sup>2</sup>	32 <sup>3</sup> 815	32 <sup>3</sup> 815
Light, detailed work:		
Desk or removable armrests	29 735	34 865
Fixed, full-size armrests <sup>2</sup>	32 <sup>3</sup> 815	34 865
Seated in a 16 in (405-mm)		
High chair:		
Manual work	26 660	27 685
Light, detailed work	28 710	31 785

<sup>1</sup>All dimensions are based on a work-surface thickness of 1 1/2 in (38 mm) and a clearance of 1 1/2 in (38 mm) between legs and the underside of a work surface.

<sup>2</sup>This type of wheelchair arm does not interfere with the positioning of a wheelchair under a work surface.

<sup>3</sup>This dimension is limited by the height of the armrests: a lower height would be preferable. Some people in this group prefer lower work surfaces, which require positioning the wheelchair back from the edge of the counter.

**A4.33 Assembly Areas.**

**A4.33.2 Size of Wheelchair Locations.** Spaces large enough for two wheelchairs allow people who are coming to a performance together to sit together.

**A4.33.3 Placement of Wheelchair Locations.** The location of wheelchair areas can be planned so that a variety of positions

**A4.33.6 Placement of Listening Systems**

<p>within the seating area are provided. This will allow choice in viewing and price categories.</p> <p>Building and life safety codes set minimum distances between rows of fixed seats with consideration of the number of seats in a row, the exit aisle width and arrangement, and the location of exit doors. "Continental" seating, with a greater number of seats per row and a commensurate increase in row spacing and exit doors, facilitates emergency egress for all people and increases ease of access to mid-row seats especially for people who walk with difficulty. Consideration of this positive attribute of "continental" seating should be included along with all other factors in the design of fixed seating areas.</p> <p>Removable armrests are recommended on fixed companion seats provided in assembly areas in amusement facilities. This provides the option for an individual using a wheelchair or other mobility device to transfer into a seat where motion and other effects may be provided as part of the amusement experience.</p> <p><b>A4.33.6 Placement of Listening Systems.</b> A distance of 50 ft (15 m) allows a person to distinguish performers' facial expressions.</p> <p><b>A4.33.7 Types of Listening Systems.</b> An assistive listening system appropriate for an assembly area for a group of persons or where the specific individuals are not known in advance, such as a playhouse, lecture hall or movie theater, may be different from the system appropriate for a particular individual provided as an auxiliary aid or as part of a reasonable accommodation. The appropriate device for an individual is the type that individual can use, whereas the appropriate system for an assembly area will necessarily be geared toward the "average" or aggregate needs of various individuals. A listening system that can be used from any seat in a seating area is the most flexible way to meet this specification. Earphone jacks with variable volume controls can benefit only people who have slight hearing loss and do not help people who use hearing aids. At the present time, magnetic induction loops are the most feasible type of</p>	<p>listening system for people who use hearing aids equipped with "T-coils," but people without hearing aids or those with hearing aids not equipped with inductive pick-ups cannot use them without special receivers. Radio frequency systems can be extremely effective and inexpensive. People without hearing aids can use them, but people with hearing aids need a special receiver to use them as they are presently designed. If hearing aids had a jack to allow a bypass of microphones, then radio frequency systems would be suitable for people with and without hearing aids. The Department of Justice's regulations implementing titles II and III of the ADA require public entities and public accommodations to provide appropriate auxiliary aids and services to ensure effective communication. See 28 CFR 35.160, 28CFR 35.164, and 28 CFR 36.303. Where assistive listening systems are used to provide effective communication, the Department of Justice considers it essential that a portion of receivers be compatible with hearing aids.</p> <p>Some listening systems may be subject to interference from other equipment and feedback from hearing aids of people who are using the systems. Such interference can be controlled by careful engineering design that anticipates feedback sources in the surrounding area.</p> <p>Table A2, shows some of the advantages and disadvantages of different types of assistive listening systems. In addition, the Access Board has published a pamphlet on Assistive Listening Systems which lists demonstration centers across the country where technical assistance can be obtained in selecting and installing appropriate systems. The state of New York has also adopted a detailed technical specification which may be useful.</p> <p><b>A4.36.2 Saunas and Steam Rooms.</b> A 60-inch turning diameter space or a T-shaped space is required within the sauna or steam room. Removable benches or seats are permitted to obstruct the 60-inch or T-shaped space.</p>
--	--

A16

**A5.0 Restaurants and Cafeterias**

<p><b>A4.37.3 Benches.</b> Back support may be achieved through locating benches adjacent to walls or by other designs that will meet the minimum dimensions specified.</p> <p><b>A5.0 Restaurants and Cafeterias.</b></p> <p><b>A5.1 General.</b> Dining counters (where there is no service) are typically found in small carry-out restaurants, bakeries, or coffee shops and may only be a narrow eating surface attached to a wall. This section requires that where such a dining counter is provided, a portion of the counter shall be at the required accessible height.</p> <p><b>A7.0 Business, Mercantile and Civic.</b></p> <p><b>A7.2(3)(iii) Counter or Teller Windows with Partitions.</b> Methods of facilitating voice communication may include grilles, slats, talk-through baffles, and other devices mounted directly into the partition which users can speak directly into for effective communication. These methods are required to be designed or placed so that they are accessible to a person who is standing or seated. However, if the counter is only used by persons in a seated position, then a method of facilitating communication which is accessible to standing persons would not be necessary.</p>	
--	--

A16A

**Table A2 Summary of Assistive Listening Devices and Systems**

<b>Table A2. Summary of Assistive Listening Devices and Systems</b>			
<b>COMPARISON OF LARGE AREA ASSISTIVE LISTENING SYSTEMS</b>			
<b>System Description</b>	<b>Advantages</b>	<b>Disadvantages</b>	<b>Typical Applications</b>
<p><b>FM BROADCAST</b> (40 frequencies available on narrow band transmission systems. Ten frequencies available on wideband transmission systems.) <b>Transmitters:</b> FM base station or personal transmitter broadcasts signal to listening area. <b>Receiver:</b> Pocket size with:</p> <ul style="list-style-type: none"> <li>a) earphone(s), or</li> <li>b) headset, or</li> <li>c) induction neck-loop or silhouette coil coupling to personal hearing aid equipped with telecoil, or</li> <li>d) direct audio input (DAI) to personal hearing aid.</li> </ul>	<ul style="list-style-type: none"> <li>• Highly portable when used with body-worn, personal transmitter.</li> <li>• Easy to install.</li> <li>• May be used separately or integrated with existing PA-systems.</li> <li>• Multiple frequencies allow for use by different groups within same area (e.g., multi-language translation).</li> </ul>	<ul style="list-style-type: none"> <li>• Signal spill-over to adjacent rooms/ listening areas (can prevent interference by using different transmission frequencies for each room/listening area). Choose infrared if privacy is essential.</li> <li>• Receivers required for everyone. Requires administration and maintenance of receivers.</li> <li>• Susceptible to electrical interference when used with induction neck-loop/silhouette (Provision of DAI audio shoes and cords is impractical for public applications).</li> <li>• Some systems more susceptible to radio wave interference and signal drift than others.</li> </ul>	<ul style="list-style-type: none"> <li>Service counters</li> <li>Outdoor guided tours</li> <li>Tour busses</li> <li>Meeting rooms</li> <li>Conference rooms</li> <li>Auditoriums</li> <li>Classrooms</li> <li>Courtrooms</li> <li>Churches and Temples</li> <li>Theaters</li> <li>Museums</li> <li>Theme parks</li> <li>Arenas</li> <li>Sport stadiums</li> <li>Retirement/nursing homes</li> <li>Hospitals</li> </ul>
<p><b>INFRARED LIGHT</b> <b>Transmitter:</b> Amplifier drives emitter panel(s) covering listening area. <b>Receivers:</b> Under-chin or Pendant type receiver with:</p> <ul style="list-style-type: none"> <li>a) headset, or</li> <li>b) earphone(s), or</li> <li>c) induction neck-loop or silhouette coil coupling to personal hearing aid equipped with telecoil, or</li> <li>d) direct audio input (DAI) to personal hearing aid.</li> </ul>	<ul style="list-style-type: none"> <li>• Unlike induction or FM transmission, IR transmission does not travel through walls or other solid surfaces.</li> <li>• Insures confidentiality.</li> <li>• Infrared receivers compatible with most infrared emitters.</li> <li>• May be used separately or integrated with existing PA-systems.</li> <li>• Can be used for multi-language translation (must use special multi-frequency receivers).</li> </ul>	<ul style="list-style-type: none"> <li>• Receivers required for everyone. Requires administration and maintenance of receivers.</li> <li>• Ineffective in direct sunlight.</li> <li>• Careful installation required to insure entire listening area will receive IR signal.</li> <li>• Susceptible to electrical interference when used with induction neckloop/silhouette (Provision of DAI audio shoes and cords is impractical for public applications).</li> <li>• Lifetime of emitters varies with company.</li> <li>• Historical buildings may pose installation problems.</li> </ul>	<ul style="list-style-type: none"> <li>Indoor service counters</li> <li>Meetings requiring confidentiality</li> <li>Meeting rooms</li> <li>Conference rooms</li> <li>Auditoriums</li> <li>Classrooms</li> <li>Courtrooms</li> <li>Churches and Temples</li> <li>Theaters</li> <li>Museums</li> <li>Arenas (indoors only)</li> <li>Sport stadiums (indoors only)</li> <li>Retirement/nursing homes</li> <li>Hospitals</li> </ul>

Modified from a chart published by Centrum Sound, Cupertino, California  
 Cynthia L. Compton, Assistive Devices Center  
 Department of Audiology and Speech-Language Pathology  
 Gallaudet University, Washington, DC  
 Continued on next page

**Table A2 Summary of Assistive Listening Devices and Systems**

<b>COMPARISON OF LARGE AREA ASSISTIVE LISTENING SYSTEMS</b>			
<b>System Description</b>	<b>Advantages</b>	<b>Disadvantages</b>	<b>Typical Applications</b>
<p><b>CONVENTIONAL INDUCTION LOOP</b>  <b>Transmitter:</b> Amplifier drives an induction loop that surrounds listening area.  <b>Receivers:</b>                      a) Personal hearing aid with telecoil.                      b) Pocket size induction receiver with earphone or headset.                      c) Self-contained wand.                      d) Telecoil inside plastic chassis which looks like a BTE, ITE, or canal hearing aid.</p>	<ul style="list-style-type: none"> <li>Requires little, or no administration of receivers, if most people have telecoil-equipped hearing aids. Induction receivers must be used where hearing aids in use are not equipped with telecoils.</li> <li>Induction receivers are compatible with all loop systems.</li> <li>Unobtrusive with telecoil hearing aid.</li> <li>May be used separately or integrated with existing PA-systems.</li> <li>Portable systems are available for use with small groups of listeners. These portable systems can be stored in a carrying case and set up temporarily, as needed.</li> </ul>	<ul style="list-style-type: none"> <li>Signal spill-over to adjacent rooms.</li> <li>Susceptible to electrical interference.</li> <li>Limited portability unless areas are pre-looped or small, portable system is used (see advantages).</li> <li>Requires installation of loop wire. Installation may be difficult in pre-existing buildings. Skilled installation essential in historical buildings (and may not be permitted at all).</li> <li>If listener does not have telecoil-equipped hearing aid then requires administration and maintenance of receivers.</li> </ul>	<p>Service counters                      Ports of transportation                      Public transportation vehicles                      Tour busses                      Meeting rooms                      Conference rooms                      Auditoriums                      Classrooms                      Courtrooms                      Churches and Temples                      Theaters                      Museums                      Theme parks                      Arenas                      Sport stadiums                      Retirement/nursing homes                      Hospitals</p>
<p><b>3-D LOOP SYSTEM</b>  <b>Transmitter:</b> Amplifier drives a 3-D mat that is placed under the carpet of the listening area.  <b>Receivers:</b>                      a) Personal hearing aid with telecoil.                      b) Pocket size induction receiver with earphone or headset.                      c) Self-contained wand.                      d) Telecoil inside plastic chassis which looks like a BTE, ITE, or canal hearing aid.</p>	<ul style="list-style-type: none"> <li>Requires little, or no administration of receivers, provided most listeners have telecoil-equipped hearing aids.</li> <li>Induction receivers are compatible with all loop systems.</li> <li>May be used separately or integrated with existing PA-systems.</li> <li>Three-dimensional reception of loop signal regardless of telecoil position.</li> <li>Reduced signal spillover allows adjacent rooms to be looped without signal interference.</li> <li>3-D loop mats must be separated by 6 feet to avoid signal spillover.</li> </ul>	<ul style="list-style-type: none"> <li>Limited portability (areas may be pre-3-D Loop matted to facilitate portability).</li> <li>Requires installation of 3-D Loop mats. Installation may be difficult in pre-existing buildings. Skilled installation essential in historical buildings (and may not be permitted at all).</li> <li>If listener does not have telecoil-equipped hearing aid then requires administration and maintenance of receivers.</li> <li>Susceptible to electrical interference.</li> </ul>	<p>Service counters                      Ports of Transportation                      Meeting rooms                      Conference rooms                      Auditoriums                      Class rooms                      Court rooms                      Museums                      Theme Parks                      Retirement/nursing homes                      Meetings requiring confidentiality                      Hospitals</p>
<p>Modified from a chart published by Centrum Sound, Cupertino, California                      Cynthia L. Compton, Assistive Devices Center                      Department of Audiology and Speech-Language Pathology                      Gallaudet University, Washington, DC</p>			

A18

**A7.2(4) Assistive Listening Systems**

**A7.2(4) Assistive Listening Systems.** At all sales and service counters, teller windows, box offices, and information kiosks where a physical barrier separates service personnel and customers, it is recommended that at least one permanently installed assistive listening device complying with 4.33 be provided at each location or series. Where assistive listening devices are installed, signage should be provided identifying those stations which are so equipped.

**A7.3 Check-out Aisles.** Section 7.2 refers to counters without aisles; section 7.3 concerns check-out aisles. A counter without an aisle (7.2) can be approached from more than one direction such as in a convenience store. In order to use a check-out aisle (7.3), customers must enter a defined area (an aisle) at a particular point, pay for goods, and exit at a particular point.

**A10.0 Transportation Facilities.****A10.3 Fixed Facilities and Stations.**

**A10.3.1(7) Route Signs.** One means of making control buttons on fare vending machines usable by persons with vision impairments is to raise them above the surrounding surface. Those activated by a mechanical motion are likely to be more detectable. If farecard vending, collection, and adjustment devices are designed to accommodate farecards having one tactually distinctive corner, then a person who has a vision impairment will insert the card with greater ease. Token collection devices that are designed to accommodate tokens which are perforated can allow a person to distinguish more readily between tokens and common coins. Thoughtful placement of accessible gates and fare vending machines in relation to inaccessible devices will make their use and detection easier for all persons with disabilities.

**A10.4 Airports.**

**A10.4.1(8) Security Systems.** This provision requires that, at a minimum, an accessible route or path of travel be provided but does not require security equipment or screening devices to be accessible. However, where barriers consist of movable equipment, it is recommended that they comply with the provisions of this section to provide persons with disabilities

the ability to travel with the same ease and convenience as other members of the general public.

**A11.0 Judicial, Legislative and Regulatory Facilities.**

**A11.1.3 Two-Way Communication Systems.** Two-way communication entry systems must provide both voice and visual display so that persons with hearing or speech impairments can utilize the system. This requirement may be met with a device that would allow security personnel to respond to a caller with a light indicating that assistance is on the way. It is important that signage be provided to indicate the meaning of visual signals.

**A11.2.1(2) Assistive Listening Systems.** People who wear hearing aids often need them while using assistive listening systems. The Department of Justice's regulation implementing title II of the ADA requires public entities to provide appropriate auxiliary aids and services where necessary to ensure effective communication. See 28 CFR 35.160 and 28 CFR 35.164. Where assistive listening systems are used to provide effective communication, the Department of Justice considers it essential that a portion of receivers be compatible with hearing aids. Receivers that are not compatible include ear buds, which require removal of hearing aids, and headsets that must be worn over the ear, which can create disruptive interference in the transmission.

**A11.2.3(2)(b) Toilet and Bathing Facilities.** The requirements of 4.22 for toilet rooms and 4.23 for bathrooms, bathing facilities, and shower rooms do not preclude the placement of toilet or bathing fixtures within housing or holding cells or rooms as long as the requirements for toilet rooms and bathrooms, including maneuvering space, are met. In such instances, the maneuvering space required within housing or holding cells or rooms may also serve as the maneuvering space required in toilet rooms by 4.22 or in bathrooms or shower rooms by 4.23.

**A11.2.3(2)(c) Beds.** The height of beds should be 17 in to 19 in (430 mm to 485 mm) measured from the finish floor to the bed surface, including mattresses or bed rolls, to ensure appropriate transfer from wheelchairs and other mobility aids. Where upper bunks are provided, sufficient clearance should be provided between bunks so that the transfer



**A11.2.3(3) Visiting Areas**

from wheelchairs to lower bunks is not restricted. Figure A3 provides average human dimensions that should be considered in determining this clearance.

**A11.2.3(3) Visiting Areas.** Accessible cubicles or portions of counters may have fixed seats if the required clear floor space is provided within the area defined by the cubicle. Consideration should be given to the placement of grilles, talk-thru baffles, intercoms, telephone handsets or other communication devices so they are usable from both the fixed seat and from the accessible seating area. If an assistive listening system is provided, the needs of the intended user and characteristics of the setting should be considered as described in A4.33.7 and Table A2.

**A11.3 Legislative and Regulatory Facilities.** Legislative facilities include town halls, city council chambers, city or county commissioners' meeting rooms, and State capitols. Regulatory facilities are those which house State and local entities whose functions include regulating, governing, or licensing activities. Section 11.3 applies to rooms where public debate, or discussion of local issues, laws, ordinances, or regulations take place. Examples include, but are not limited to, legislative chambers and hearing rooms, facilities where town, county council or school Board meetings, and housing authority meetings are held, and rooms accommodating licensing or other regulatory Board hearings, adjudicatory administrative hearings (e.g., drivers license suspension hearings) and zoning application and waiver proceedings.

**A11.3.2** See A11.2.1(2).

**A12.0 Detention and Correctional Facilities.**

**A12.1 General.** All common use areas serving accessible cells or rooms are required to be accessible. In detention and correctional facilities, common use areas include those areas serving a group of inmates or detainees, including, but not limited to, exercise yards and recreation areas, workshops and areas of instruction or vocational training, counseling centers, cafeterias, commissaries, medical facilities, and any other rooms, spaces, or elements that are made available for the use of a group of inmates or detainees. Detention and correctional facilities also contain areas that

may be regarded as common use areas which specifically serve a limited number of housing cells or rooms. Where this occurs, only those common use areas serving accessible cells or rooms would need to be accessible as required by 12.5. For example, several housing cells may be located at and served by a dayroom or recreation room. In this instance, only those dayrooms serving accessible housing cells or rooms would need to be accessible. However, common use areas that do not serve accessible cells but that are used by the public or by employees as work areas are still subject to the requirements for public use areas and employee work areas in section 4.

**A.12.2.1 Entrances.** Persons other than inmates and facility staff, such as counselors and instructors, may have access to secured areas. It is important that evacuation planning address egress for all possible users since a person with a disability might not be able to independently operate doors permitted by this exception.

**A12.3 Visiting Areas.** Accessible cubicles or portions of counters may have fixed seats if the required clear floor space is provided within the area defined by the cubicle. Consideration should be given to the placement of grilles, talk-thru baffles, intercoms, telephone handsets or other communication devices so they are usable from both the fixed seat and from the accessible seating area. If an assistive listening system is provided, the needs of the intended user and characteristics of the setting should be considered as described in A4.33.7 and Table A2.

**A12.4.1 Holding Cells and General Housing Cells or Rooms.** Accessible cells or rooms should be dispersed among different levels of security, housing categories and holding classifications (e.g., male/female and adult/juvenile) to facilitate access. Many detention and correctional facilities are designed so that certain areas (e.g., "shift" areas) can be adapted to serve as different types of housing according to need. For example, a shift area serving as a medium security housing unit might be redesignated for a period of time as a high security housing unit to meet capacity needs. Placement of accessible cells or rooms in shift areas may allow additional flexibility in meeting requirements for dispersion of accessible cells or rooms.

A20

**A12.4.2 Special Holding and Housing Cells or Rooms**

**A12.4.2 Special Holding and Housing Cells or Rooms.** While one of each type of special purpose cell is required to be accessible at a facility, constructing more than one of each type to be accessible will facilitate access at large facilities where cells of each type serve different holding areas or housing units. The requirement for medical isolation cells applies only to those specifically designed for medical isolation. Cells or rooms primarily designed for other purposes, such as general housing or medical care, are subject to the requirements in 12.4.1 or 12.4.4, respectively. Medical isolation cells required to be accessible by 12.4.2 shall not be counted as part of the minimum number of patient bedrooms or cells required to be accessible in 12.4.4. Thus, if a medical care facility has both types of cells, at least one medical isolation cell must be accessible under 12.4.2 in addition to the number of patient bedrooms or cells required to be accessible by 12.4.4. While only one medical isolation cell per facility is required to be accessible, it is recommended that consideration be given to ensuring the accessibility of all medical isolation cells.

**A12.4.3 Accessible Cells or Rooms for Persons with Hearing Impairments.** Many correctional facilities do not provide permanently installed telephones or alarms within individual housing cells. Such facilities are not subject to the requirements of 12.4.3. However, some categories of housing, such as minimum security prisons, may be equipped with such devices. The minimum two percent is based on the number of cells or rooms equipped with these devices and not on the total number of cells or rooms in the facility. In addition, this requirement applies only where permanently installed telephones or alarms are provided within individual cells. Permanently installed telephones and alarms located in common use areas, such as dayrooms, are required to be accessible according to the requirements for common use areas. See 12.1.

**A12.5.2 Minimum Requirements.** The requirements of this section apply to elements provided within housing or holding cells or rooms. Elements located outside cells or rooms for common use, such as in a day room, are subject to 12.1 and its application of requirements in section 4. For example, if a drinking fountain is provided within an accessible housing or holding cell, at least one must be wheelchair accessible under section 12.5.2(4). Drinking fountains located outside the cells in

common use areas serving accessible cells or in public use areas, are subject to the requirements of 4.1.3(10).

**A12.5.2(2) Toilet and Bathing Facilities.** The requirements of 4.22 for toilet rooms and 4.23 for bathrooms, bathing facilities, and shower rooms do not preclude the placement of toilet or bathing fixtures within housing or holding cells or rooms as long as the requirements for toilet rooms and bathrooms, including maneuvering ce, are met. In such instances, the maneuvering space required within housing or holding cells or rooms may also serve as the maneuvering space required in toilet rooms by 4.22 or in bathrooms or shower rooms by 4.23.

**A12.5.2(3) Beds.** Since beds may not always be fixed, a minimum number of accessible beds has not been specified. In barracks-style rooms with many beds, it is recommended that the scoping requirement for housing or holding cells or rooms (2 percent) also be applied to the number of beds in accessible cells or rooms.

The height of beds should be 17 to 19 in (430 mm to 485 mm) measured from the finish floor to the bed surface, including mattresses or bed rolls, to ensure appropriate transfer from wheelchairs and other mobility aids. Where upper bunks are provided, sufficient clearance must be provided between bunks so that the transfer from wheelchairs to lower bunks is not restricted. Figure A3 provides standard human dimensions that should be considered in determining this clearance.

**A15.0 Recreation Facilities**

<p><b>A15.0 Recreation Facilities.</b></p> <p>Unless otherwise modified in Section 4 or specifically addressed in section 15, all other ADAAG provisions apply for the design and construction of recreation facilities and elements. The provisions in this section apply wherever these elements are provided. For example, office buildings may contain a room with exercise equipment and these sections therefore apply.</p> <p><b>A15.1 Amusement Rides.</b></p> <p>These guidelines apply to newly designed or newly constructed amusement rides. A custom designed and constructed ride is new upon its "first use," which is the first time amusement park patrons take the ride. With respect to amusement rides purchased from other entities, "new" refers to the first permanent installation of the ride, whether it is used "off the shelf" or it is modified before it is installed. Where amusement rides are moved after several seasons to another area of the park or to another park, the ride would not be considered newly designed or newly constructed.</p> <p>Amusement rides designed primarily for children, amusement rides that are controlled or operated by the rider, and amusement rides without seats, are not required to provide wheelchair spaces, transfer seats, or transfer systems, and need not meet the signage requirements in 15.1.6. The load and unload areas of these rides must, however, be on an accessible route and must provide maneuvering space under 15.1.4 and 15.1.5.</p> <p>The scoping and technical provisions of the guidelines were developed to address common amusement rides. There will be other amusement attractions that have unique designs and features which are not adequately addressed by the guidelines. In those situations, the guidelines are to be applied to the extent possible.</p> <p>An accessible route must be provided to these areas. Where an attraction or ride has unique features for which there are no applicable scoping provisions, then a reasonable number, but at least one, of the features must be located on an</p>	<p>accessible route. Where there are appropriate technical provisions, they must be applied to the elements that are covered by the scoping provisions. Where an attraction has unique designs for which the technical provisions are not appropriate, the operators of those attractions are still subject to all the other requirements of the ADA, including program accessibility, barrier removal and the general obligation to provide individuals with disabilities an equal opportunity to enjoy the goods and services provided by their facilities. An example of an amusement ride not specifically addressed by the guidelines includes "virtual reality" rides where the device does not move through a fixed course within a defined area.</p> <p><b>A15.1 Exception 1.</b> Mobile or temporary rides are those set up for short periods of time such as traveling carnivals, State and county fairs, and festivals. The amusement rides that are covered by section 15.1 are ones that are not regularly assembled and disassembled.</p> <p><b>A15.1 Exception 2.</b> The exception does not apply to those rides where patrons may cause the ride to make incidental movements, but where the patron otherwise has no control over the ride.</p> <p><b>A15.1 Exception 3.</b> The exception is limited to those rides designed "primarily" for children, where children are assisted on and off the ride by an adult. This exception is limited to those rides designed for children and not for the occasional adult user. An accessible route to and maneuvering space in the load and unload area will provide access for adults and family members assisting children on and off these rides.</p> <p><b>A15.1.2 Alterations to Amusement Rides.</b> Routine maintenance, painting, and changing of theme boards are examples of activities that do not constitute an alteration subject to section 15.1.2. Where existing amusement rides are moved and not altered, section 15.1 does not apply unless the load and unload area of the amusement ride is newly designed and constructed. If a load or unload area is altered, the alteration provisions of ADAAG 4.1.6 must be applied to the altered area.</p>
---	--

A22

**A15.1 Amusement Rides**

**A15.1.4 Accessible Route.** Steeper slopes are permitted (not to exceed 1:8) where the accessible route connects to the amusement ride in the load and unload position. This is permitted only where compliance with 4.8.2 (maximum slope 1:12) is "structurally or operationally infeasible". In most cases, this will be limited to areas where the accessible route leads directly to the amusement ride and where there are space limitations on the ride, not the queue line. Where possible, the least possible slope should be used on the accessible route that serves the amusement ride.

**A15.1.7.1.2 Amusement Rides with Wheelchair Spaces.** 36 CFR 1192.83(c) ADA Accessibility Guidelines for Transportation Vehicles - Light Rail Vehicles and Systems - Mobility Aid Accessibility is available at [www.access-board.gov/transit/html/vguide.htm#LRVM](http://www.access-board.gov/transit/html/vguide.htm#LRVM). It references provisions for bridge plates and ramps used for gaps between wheelchair spaces and floors of load and unload areas.

**A15.1.7.2 Exception 3.** This exception for protruding objects applies to the ride devices, not to circulation areas or accessible routes in the queue lines or the load and unload areas.

**A15.1.7.2.2 Wheelchair Spaces - Side Entry.** Under certain circumstances, a 32-inch clear opening will not provide sufficient width to accommodate a turn into an amusement ride. The amount of clear space needed within the ride, and the size and position of the opening are interrelated. Additional space for maneuvering and a wider door will be needed where a side opening is centered on the ride. For example, where a 42-inch opening is provided, a minimum clear space of 60 inches in length and 36 inches in depth is needed (see Fig. A9). This is necessary to ensure adequate space for maneuvering. For additional guidance refer to Figure 3 (Wheelchair Turning Space) and Figure 4 (Minimum Clear Floor Space for Wheelchairs) on minimum space requirements.

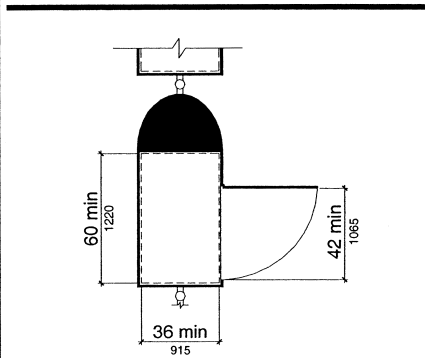

Fig. A9  
Wheelchair Spaces - Side Entry

**A15.1.8 Amusement Ride Seats Designed for Transfer.** There are many different ways that individuals transfer to and from their wheelchairs or mobility devices. The proximity of the clear floor or ground space next to an element and the height of the element one is transferring to are both critical for a safe and independent transfer. Providing additional clear floor or ground space both in front of and diagonally to the element will provide flexibility and increased usability for a more diverse population of individuals with disabilities. Ride seats designed for transfer should involve only one transfer. Where possible, designers are encouraged to locate the ride seat no higher than 17 to 19 inches above the load and unload surface. Where greater distances are required for transfers, consideration should be given to providing gripping surfaces, seat padding, and avoiding sharp or protruding objects in the path of transfer to better facilitate the transfer process.

**A15.1.9 Transfer Devices for Use with Amusement Rides.** Transfer devices for use with

**A15.2 Boating Facilities**

<p>amusement rides should permit individuals to make independent transfers to and from their wheelchairs or mobility devices. There are a variety of transfer devices available that could be adapted to provide access onto an amusement ride. Examples of devices that may provide for transfers include, but are not limited to, transfer systems (see 15.8.8), lifts, mechanized seats, and other custom designed systems. Operators and designers have flexibility in developing designs that will facilitate individuals to transfer onto amusement rides. These systems or devices should be designed to be reliable and sturdy. A transfer board, for example, would not be sufficient because it will not provide enough support or stability and may cause injury.</p> <p>Designs which limit the number of transfers required from one's wheelchair or mobility device to the ride seat are encouraged. When using a transfer device to access an amusement ride, the least amount of transfers for the least amount of distance is desired. Where possible, designers are encouraged to locate the transfer device seat no higher than 17 to 19 inches above the load and unload surface. Where greater distances are required for transfers, consideration should be given to providing gripping surfaces, seat padding, and avoiding sharp or protruding objects in the path of transfer to better facilitate the transfer process. Where a series of transfers are required to reach the amusement ride seat, each vertical transfer should not exceed 8 inches.</p> <p>As discussed with amusement rides seats designed for transfer, there are many different ways that individuals transfer to and from their wheelchairs or mobility devices. The proximity of the clear floor or ground space next to an element and the height of the element one is transferring to are both critical for a safe and independent transfer. Providing additional clear floor or ground space both in front of and diagonally to the element will provide flexibility and increased usability for a more diverse population of individuals with disabilities.</p>	<p><b>A15.2 Boating Facilities.</b></p> <p><b>A15.2.2 Accessible Route.</b> The following two examples apply exceptions two and three.</p> <p>Example 1. Boat slips which are required to be accessible are provided at a floating pier. The vertical distance an accessible route must travel to the pier when the water is at its lowest level is six feet, although the water level only fluctuates three feet. To comply with exceptions 2 and 3, at least one design solution would provide a gangway at least 72.25 feet long which ensures the slope does not exceed 1:12.</p> <p>Example 2. A gangway is provided to a floating pier which is required to be on an accessible route. The vertical distance is 10 feet between the elevation where the gangway departs the landside connection and the elevation of the pier surface at the lowest water level. Exceptions 2 and 3, which modify 4.8.2, permit the gangway to be at least 80 feet long. Another design solution would be to have two 40-foot continuous gangways joined together at a float, where the float (as the water level falls) will stop dropping at an elevation five feet below the landside connection.</p> <p><b>A15.2.3 Boat Slips: Minimum Number.</b> Accessible boat slips are not "reserved" for persons with disabilities in the same manner as accessible vehicle parking spaces. Rather, accessible boat slip use is comparable to accessible hotel rooms. The Department of Justice is responsible for addressing operational issues relating to the use of accessible facilities and elements. The Department of Justice currently advises that hotels should hold accessible rooms for persons with disabilities until all other rooms are filled. At that point, accessible rooms can be open for general use on a first come, first serve basis.</p> <p>The following two examples apply to a boating facility with a single non-demarcated pier.</p> <p>Example 1. A site contains a new boating facility which consists of a single 60-foot pier. Boats are only moored parallel with the pier on both sides to allow occupants to embark or disembark.</p>
---	--

A24

**A15.2 Boating Facilities**

<p>Since the number of slips cannot be identified, section 15.2.3 requires each 40 feet of boat slip edge to be counted as one slip for purposes of determining the number of slips available and determines the number required to be accessible. The 120 feet of boat slip edge at the pier would equate with 3 boat slips. Table 15.2.3 would require 1 slip to be accessible and comply with 15.2.5. Section 15.2.5 (excluding the exceptions within the section) requires a clear pier space 60 inches wide minimum extending the length of the slip. In this example, because the pier is at least 40 feet long, the accessible slip must contain a clear pier space at least 40 feet long which has a minimum width of 60 inches.</p> <p>Example 2. A new boating facility consisting of a single pier 25 feet long and 3 feet wide is being planned for a site. The design intends to allow boats to moor and occupants to embark and disembark on both sides, and at one end. As the number of boat slips cannot be identified, applying section 15.2.3 would translate to 53 feet of boat slip edge at the pier. This equates with two slips. Table 15.2.5 would require 1 slip to be accessible. To comply with 15.2.5 (excluding the exceptions within the section), the width of the pier must be increased to 60 inches. Neither 15.2.3 or 15.2.5 requires the pier length to be increased to 40 feet.</p> <p><b>A15.2.3.1 Dispersion.</b> Types of boat slips are based on the size of the boat slips; whether single berths or double berths, shallow water or deep water, transient or longer-term lease, covered or uncovered; and whether slips are equipped with features such as telephone, water, electricity and cable connections. The term "boat slip" is intended to cover any pier area where recreational boats embark or disembark, unless classified as a launch ramp boarding pier. For example, a fuel pier may contain boat slips, and this type of short term slip would be included in determining compliance with 15.2.3.1.</p> <p><b>A15.2.4 Boarding Piers at Boat Launch Ramps.</b> The following two examples apply to a boat launch ramp boarding pier.</p>	<p>Example 1. A chain of floats is provided on a launch ramp to be used as a boarding pier which is required to be accessible by 15.2.4. At high water, the entire chain is floating and a transition plate connects the first float to the surface of the launch ramp. As the water level decreases, segments of the chain end up resting on the launch ramp surface, matching the slope of the launch ramp. As water levels drop, segments function also as gangways because one end of a segment is resting on the launch ramp surface and the other end is connecting to another floating segment in the chain.</p> <p>Under ADAAG 4.1.2(2), an accessible route must serve the last float because it would function as the boarding pier at the lowest water level. Under exception 3 in 15.2.4, each float is not required to comply with ADAAG 4.8, but must meet all other requirements in ADAAG 4.3, unless exempted by exception 1 in 15.2.4. In this example, because the entire chain also functions as a boarding pier, the entire chain must comply with the requirements of 15.2.5, including the 60-inch minimum clear pier width provision.</p> <p>Example 2. A non-floating boarding pier supported by piles divides a launching area into two launch ramps and is required to be accessible. Under ADAAG 4.1.2(2), an accessible route must connect the boarding pier with other accessible buildings, facilities, elements, and spaces on the site. Although the boarding pier is located within a launch ramp, because the pier is not a floating pier or a skid pier, none of the exceptions in 15.2.4 apply. To comply with ADAAG 4.3, either the accessible route must run down the launch ramp or the fixed boarding pier could be relocated to the side of the two launch ramps. The second option leaves the slope of the launch ramps unchanged, because the accessible route runs outside the launch ramps.</p> <p><b>A15.2.4.1 Boarding Pier Clearances.</b> The guidelines do not establish a minimum length for accessible boarding piers at boat launch ramps. The accessible boarding pier would have a length which is at least equal to other boarding piers provided at the facility. If no other boarding pier</p>
--	--

**A15.3 Fishing Piers and Platforms**

<p>is provided, the pier would have a length equal to what would have been provided if no access requirements applied. The entire length of accessible boarding piers would be required to comply with the same technical provisions that apply to accessible boat slips. For example, at a launch ramp, if a 20-foot long accessible boarding pier is provided, the entire 20 feet must comply with the pier clearance requirements in 15.2.5. Likewise, if a 60-foot long accessible boarding pier is provided, the pier clearance requirements in 15.2.5 would apply to the entire 60 feet.</p> <p><b>A15.2.5 Accessible Boat Slips.</b> Although the minimum width of the clear pier space is 60 inches, it is recommended that piers be wider than 60 inches to improve the safety for persons with disabilities, particularly on floating piers.</p> <p><b>A15.2.5.1 Clearances, Exception 3.</b> Where the conditions in exception 3 are satisfied, existing facilities are only required to have one accessible boat slip with a pier clearance which runs the length of the slip. All other accessible slips are allowed to have the required pier clearance at the head of the slip. Under this exception, at piers with perpendicular boat slips, the width of most "finger piers" will remain unchanged. However, where mooring systems for floating piers are replaced as part of pier alteration projects, an opportunity may exist for increasing accessibility. Piers may be reconfigured to allow an increase in the number of wider finger piers, and serve as accessible boat slips.</p> <p><b>A15.3 Fishing Piers and Platforms.</b></p> <p><b>A15.3.3.1 Edge Protection.</b> Edge protection is required only where railings, guards, or handrails are provided on a fishing pier or platform. Edge protection will prevent wheelchairs or other mobility devices from slipping off the fishing pier or platform. Extending the deck of the fishing pier or platform 12 inches where the 34-inch high railing is provided is an alternative design, permitting individuals using a wheelchair or other mobility device to pull into a clear space and move beyond the face of the railing. In such a design, edge protection is not required.</p>	<p><b>A15.3.2 Accessible Route, Exception 2.</b> For example, to provide access to an accessible floating fishing pier, a gangway is used. The vertical distance is 60 inches between the elevation that the gangway departs the landside connection and the elevation of the pier surface at the lowest water level. Exception 2 permits the use of a gangway at least 30 feet long, or a series of connecting gangways with a total length of at least 30 feet. The length of transition plates would not be included in determining if the gangway(s) meet the requirements of the exception.</p> <p><b>A15.3.3.3 Dispersion.</b> Portions of the railings that are lowered to provide fishing opportunities for persons with disabilities must be located in a variety of locations on the fishing pier or platform to give people a variety of locations to fish. Different fishing locations may provide varying water depths, shade (at certain times of the day), vegetation, and proximity to the shoreline or bank.</p> <p><b>A15.4 Golf.</b></p> <p><b>A15.4.2 Accessible Routes.</b> The accessible route or golf car passage must serve accessible elements and spaces located within the boundary of a golf course. The 48-inch minimum width for the accessible route is necessary to ensure passage of a golf car on either the accessible route or the golf car passage. This is important where the accessible route is used to connect the golf car rental area, bag drop areas, practice putting greens, accessible practice teeing grounds, course toilet rooms, and course weather shelters. These are areas outside the boundary of the golf course, but are areas where an individual using an adapted golf car may travel. A golf car passage may not be substituted for other accessible routes, required by ADAAG 4.1.2, located outside the boundary of the course. For example, an accessible route connecting an accessible parking space to the entrance of a golf course clubhouse is not covered by this provision.</p> <p><b>A15.4.3 Accessible Route - Driving Ranges.</b> Both a stand alone driving range or a driving range next to a golf course must provide an</p>
--	---

A26

**A15.5 Miniature Golf**

<p>accessible route or golf car passage that connects accessible teeing stations with accessible parking spaces. The accessible route must be a minimum width of 48 inches; 60 inches if handrails are provided. The additional width permits the use of a golf car on the accessible route. Providing a golf car passage will permit a person that uses a golf car to practice driving a golf ball from the same position and stance used when playing the game. Additionally, the space required for a person using a golf car to enter and exit the teeing stations required to be accessible should be considered.</p> <p><b>A15.5 Miniature Golf.</b></p> <p>Where possible, providing access to all holes on a miniature golf course is recommended. If a course is designed with the minimum 50 percent accessible holes, designers or operators are encouraged to select holes which provide for an equivalent experience to the maximum extent possible. Accessible holes are required to be consecutive with one break permitted, if the last hole on the course is in the sequence.</p> <p><b>A15.5.3 Accessible Route.</b> Where only the minimum 50 percent of the holes are accessible, an accessible route from the last accessible hole to the course exit or entrance must not require travel back through other holes. In some cases, this may require an additional route. Other options include increasing the number of accessible holes in a way that limits the distance needed to connect the last accessible hole with the course exit or entrance. In any case, careful consideration to the layout of the course will be important to minimize space impacts.</p> <p>The 1-inch curb for a 32-inch minimum opening can be located in an area where the ball is less likely to ricochet. Where the accessible route on the hole is provided, steeper slopes are permitted for a limited distance. A landing or level area must separate each of these steeper sloping segments. This will provide a resting area between the steeper segments.</p> <p><b>A15.5.5 Golf Club Reach Range.</b> Accessible holes on a miniature golf course may be provided with an accessible route leading through the hole</p>	<p>or with the accessible route next to the hole. Where the accessible route is provided adjacent to the hole, the route must be located within the golf club reach range. This allows individuals sufficient space and reach to play the game outside of the hole. Where possible, the distance between the level areas and the accessible route should be as close as possible, affording more opportunities for play.</p> <p><b>A15.6 Play Areas.</b></p> <p><b>A15.6.1 General.</b> This section is to be applied during the design, construction, and alteration of play areas for children ages 2 and over. Play areas are the portion of a site where play components are provided. This section does not apply to other portions of a site where elements such as sports fields, picnic areas, or other gathering areas are provided. Those areas are addressed by other sections of ADAAG. Play areas may be located on exterior sites or within a building. Where separate play areas are provided within a site for children in specified age groups (e.g., preschool (ages 2 to 5) and school age (ages 5 to 12)), each play area must comply with this section. Where play areas are provided for the same age group on a site but are geographically separated (e.g., one is located next to a picnic area and another is located next to a softball field), they are considered separate play areas and each play area must comply with this section.</p> <p><b>A15.6.2 Ground Level Play Components.</b> A ground level play component is a play component approached and exited at the ground level. Examples of ground level play components include spring rockers, swings, diggers, and stand alone slides. When distinguishing between the different types of ground level play components, consider the general experience provided by the play component. Examples of different types of experiences include, but are not limited to, rocking, swinging, climbing, spinning, and sliding. A spiral slide may provide a slightly different experience from a straight slide, but sliding is the general experience and therefore a spiral slide is not considered a different type of play component than a straight slide.</p>
---	---



**A15.6 Play Areas**

<p>The number of ground level play components is not dependent on the number of children who can play on the play component. A large seesaw designed to accommodate ten children at once is considered one ground level play component.</p> <p>Where a large play area includes two or more composite play structures designed for the same age group, the total number of elevated play components on all the composite play structures must be added to determine the additional number and types of ground level play components that must be provided on an accessible route, and the type of accessible route (e.g., ramps or transfer systems) that must be provided to the elevated play components.</p> <p>Ground level play components accessed by children with disabilities must be integrated in the play area. Designers should consider the optimal layout of ground level play components accessed by children with disabilities to foster interaction and socialization among all children. Grouping all ground level play components accessed by children with disabilities in one location is not considered integrated.</p> <p><b>A15.6.3 Elevated Play Components.</b> Elevated play components are approached above or below grade and are part of a composite play structure. A double or triple slide that is part of a composite play structure is one elevated play component. For purposes of this section, ramps, transfer systems, steps, decks, and roofs are not considered elevated play components. These elements are generally used to link other elements on a composite play structure. Although socialization and pretend play can occur on these elements, they are not primarily intended for play. Some play components that are attached to a composite play structure can be approached or exited at the ground level or above grade from a platform or deck. For example, a climber attached to a composite play structure can be approached or exited at the ground level or above grade from a platform or deck on a composite play structure. Play components that are attached to a composite play structure and can be approached from a platform or deck (e.g.,</p>	<p>climbers and overhead play components), are considered elevated play components. These play components are not considered ground level play components also, and do not count toward the requirements in 15.6.2 regarding the number of ground level play components that must be located on an accessible route.</p> <p><b>A15.6.4 Accessible Routes.</b> Accessible routes within the boundary of the play area must comply with 15.6.4. Accessible routes connecting the play area to parking, drinking fountains, and other elements on a site must comply with 4.3. Accessible routes provide children who use wheelchairs or other mobility devices the opportunity to access play components. Accessible routes should coincide with the general circulation path used within the play area. Careful placement and consideration of the layout of accessible routes will enhance the ability of children with disabilities to socialize and interact with other children.</p> <p>Where possible, designers and operators are encouraged to provide wider ground level accessible routes within the play area or consider designing the entire ground surface to be accessible. Providing more accessible spaces will enhance the integration of all children within the play area and provide access to more play components. A maximum slope of 1:16 is required for ground level ramps; however, a lesser slope will enhance access for those children who have difficulty negotiating the 1:16 maximum slope. Handrails are not required on ramps located within ground level use zones.</p> <p>Where a stand alone slide is provided, an accessible route must connect the base of the stairs at the entry point, and the exit point of the slide. A ramp or transfer system to the top of the slide is not required. Where a sand box is provided, an accessible route must connect to the border of the sand box. Accessibility to the sand box would be enhanced by providing a transfer system into the sand or by providing a raised sand table with knee clearance complying with 15.6.6.3.</p>
--	---

A28

**A15.6 Play Areas**

Elevated accessible routes must connect the entry and exit points of at least 50 percent of elevated play components. Ramps are preferred over transfer systems since not all children who use wheelchairs or other mobility devices may be able to use or may choose not to use transfer systems. Where ramps connect elevated play components, the maximum rise of any ramp run is limited to 12 inches. Where possible, designers and operators are encouraged to provide ramps with a lesser slope than the 1:12 maximum. Berms or sculpted dirt may be used to provide elevation and may be part of an accessible route to composite play structures.

Platform lifts complying with 4.11 and applicable State and local codes are permitted as a part of an accessible route. Because lifts must be independently operable, operators should carefully consider the appropriateness of their use in unsupervised settings.

**A15.6.5 Transfer Systems.** Transfer systems are a means of accessing composite play structures. Transfer systems generally include a transfer platform and a series of transfer steps. Children who use wheelchairs or other mobility devices transfer from their wheelchair or mobility devices onto the transfer platform and lift themselves up or down the transfer steps and scoot along the decks or platforms to access elevated play components. Some children may be unable or may choose not to use transfer systems. Where transfer systems are provided, consideration should be given to the distance between the transfer system and the elevated play components. Moving between a transfer platform and a series of transfer steps requires extensive exertion for some children. Designers should minimize the distance between the points where a

child transfers from a wheelchair or mobility device and where the elevated play components are located. Where elevated play components are used to connect to another elevated play component in lieu of an accessible route, careful consideration should be used in the selection of the play components used for this purpose. Transfer supports are required on transfer platforms and transfer steps to assist children when transferring. Some examples of supports include a rope loop, a loop type handle, a slot in the edge of a flat horizontal or vertical member, poles or bars, or D rings on the corner posts.

**A15.6.6 Play Components.** Clear floor or ground spaces, maneuvering spaces, and accessible routes may overlap within play areas. A specific location has not been designated for the clear floor or ground spaces or maneuvering spaces, except swings, because each play component may require that the spaces be placed in a unique location. Where play components include a seat or entry point, designs that provide for an unobstructed transfer from a wheelchair or other mobility device are recommended. This will enhance the ability of children with disabilities to independently use the play component.

When designing play components with manipulative or interactive features, consider appropriate reach ranges for children seated in wheelchairs. The following table provides guidance on reach ranges for children seated in wheelchairs. These dimensions apply to either forward or side reaches. The reach ranges are appropriate for use with those play components that children seated in wheelchairs may access and reach. Where transfer systems provide access to elevated play components, the reach ranges are not appropriate.

**Children's Reach Ranges**

<b>Forward or Side Reach</b>	<b>Ages 3 and 4</b>	<b>Ages 5 through 8</b>	<b>Ages 9 through 12</b>
<b>High (maximum)</b>	36 in (915 mm)	40 in (1015 mm)	44 in (1120 mm)
<b>Low (minimum)</b>	20 in (510 mm)	18 in (455 mm)	16 in (405 mm)

A29

**A15.7 Exercise Equipment and Machines**

<p>Where a climber is located on a ground level accessible route, some of the climbing rings should be within the reach ranges. A careful balance of providing access to play components but not eliminating the challenge and nature of the activity is encouraged.</p> <p><b>A15.6.7 Ground Surfaces.</b> Ground surfaces along clear floor or ground spaces, maneuvering spaces, and accessible routes must comply with the ASTM F 1951 Standard Specification for Determination of Accessibility to Surface Systems Under and Around Playground Equipment. The ASTM F 1951 standard is available from the American Society for Testing and Materials (ASTM), 100 Barr Harbor Drive, West Conshohocken, PA 19428-2959, telephone (610) 832-9585. The ASTM F 1951 standard may be ordered online from ASTM (<a href="http://www.astm.org">http://www.astm.org</a>). The ASTM F 1951 standard determines the accessibility of a surface by measuring the work required to propel a wheelchair across the surface. The standard includes tests of effort for both straight ahead and turning movement, using a force wheel on a rehabilitation wheelchair as the measuring device. To meet the standard, the force required must be less than that required to propel the wheelchair up a ramp with a 1:14 slope. When evaluating ground surfaces, operators should request information about compliance with the ASTM F 1951 standard.</p> <p>Ground surfaces must be inspected and maintained regularly and frequently to ensure continued compliance with the ASTM F 1951 standard. The type of surface material selected and play area use levels will determine the frequency of inspection and maintenance activities.</p> <p>When using a combination of surface materials, careful design is necessary to provide appropriate transitions between the surfaces. Where a rubber surface is installed on top of asphalt to provide impact attenuation, the edges of the rubber surface may create a change in level between the adjoining ground surfaces. Where the change in level is greater than ½ inch, a sloped surface with a maximum slope of 1:12 must be provided.</p>	<p>Products are commercially available that provide a 1:12 slope at transitions. Transitions are also necessary where the combination of surface materials include loose fill products. Where edging is used to prevent the loose surface from moving onto the firmer surface, the edging may create a tripping hazard. Where possible, the transition should be designed to allow for a smooth and gradual transition between the two surfaces.</p> <p><b>A15.7 Exercise Equipment and Machines, Bowling Lanes, and Shooting Facilities.</b></p> <p><b>A15.7.2 Exercise Equipment and Machines.</b> Fitness facilities often provide a range of choices of exercise equipment. At least one of each type of exercise equipment and machine must be served by an accessible route. Most strength training equipment and machines are considered different types. For example, a bench press machine is considered a different type than a biceps curl machine. The requirement for providing access to each type is intended to cover the variety of strength training machines. Where operators provide a biceps curl machine and free weights, both are required to meet the provisions in this section, even though an individual may be able to work on their biceps through both types of equipment. Where the exercise equipment and machines provided are only different in that different manufacturers provide them, only one of each type of machine is required to meet these guidelines. For example, where two bench press machines are provided and each is manufactured by a different company, only one is required to comply.</p> <p>Similarly, there are many types of cardiovascular exercise machines, such as stationary bicycles, rowing machines, stair climbers, and treadmills. Each machine provides a cardiovascular exercise and is considered a different type for purposes of these guidelines.</p> <p>One clear floor or ground space is permitted to be shared between two pieces of exercise equipment. Designers should carefully consider layout</p>
--	---

A30

**A15.8 Swimming Pools, Wading Pools, and Spas**

<p>options to maximize space such as connecting ends of the row and center aisle spaces.</p> <p>The position of the clear floor space may vary greatly depending on the use of the equipment or machine. For example, to make a shoulder press accessible, clear floor space next to the seat would be appropriate to allow for transfer. Clear floor space for a bench press machine designed for use by an individual seated in a wheelchair, however, will most likely be centered on the operating mechanisms.</p> <p>Designers and operators are encouraged to select exercise equipment and machines that provide fitness opportunities for persons with lower body extremity disabilities. Upper body exercise equipment and machines that offer either cardiovascular or strength training will enhance fitness opportunities for persons with disabilities from a wheelchair or mobility device. Examples include: equipment or machines that provide arm ergometry, free weights, and weighted pulley systems that are usable from a wheelchair or mobility device.</p> <p><b>A15.7.4. Shooting Facilities.</b> Examples of different types of firing positions include, but are not limited to: positions having different admission prices, positions with or without weather covering or lighting, and positions supporting different shooting events such as argon, muzzle loading rifle, small bore rifle, high power rifle, bull's eye pistol, action pistol, silhouette, trap, skeet, and archery (bow and crossbow).</p> <p><b>A15.8 Swimming Pools, Wading Pools, and Spas.</b></p> <p><b>A15.8.2 Swimming Pools.</b> Where more than one means of access is provided into the water, it is recommended that the means be different. Providing different means of access will better serve the varying needs of people with disabilities in getting into and out of a swimming pool. It is also recommended that where two or more means of access are provided, they not be provided in the same location in the pool. Different locations will</p>	<p>provide increased options for entry and exit, especially in larger pools.</p> <p><b>A15.8.2 Swimming Pools, Exception 1.</b> Pool walls at diving areas and areas along pool walls where there is no pool entry because of landscaping or adjacent structures should be counted when determining the number of accessible means of entry required.</p> <p><b>A15.8.5 Pool Lifts.</b> There are a variety of seats available on pool lifts ranging from sling seats to those that are preformed or molded. Pool lift seats with backs will enable a larger population of persons with disabilities to use the lift. Pool lift seats that consist of materials that resist corrosion and provide a firm base to transfer will be usable by a wider range of people with disabilities. Additional options such as armrests, head rests, seat belts, and leg support will enhance accessibility and better accommodate people with a wide range of disabilities.</p> <p><b>A15.8.5.6 Footrests and Armrests.</b> Footrests are encouraged on lifts used in larger spas, where the foot well water depth is 34 inches or greater. Providing footrests, especially ones that support the entire foot, will facilitate safe and independent transfers by a larger population of persons with disabilities.</p> <p><b>A15.8.5.7 Operation.</b> Pool lifts must be capable of unassisted operation from both the deck and water levels. This will permit a person to call the pool lift when the pool lift is in the opposite position. It is extremely important for a person who is swimming alone to be able to call the pool lift when it is in the up position so he or she will not be stranded in the water for extended periods of time awaiting assistance. The requirement for a pool lift to be independently operable does not preclude assistance from being provided.</p> <p><b>A15.8.5.9 Lifting Capacity.</b> Single person pool lifts must be capable of supporting a minimum weight of 300 pounds and sustaining a static load of at least one and a half times the rated load. Pool lifts should be provided that meet the needs of the population it is serving. Providing a pool lift</p>
---	--

**A15.8 Swimming Pools, Wading Pools and Spas**

<p>with a weight capacity greater than 300 pounds may be advisable.</p> <p><b>A15.8.6.1 Sloped Entries.</b> Personal wheelchairs and mobility devices may not be appropriate for submerging in water. Some may have batteries, motors, and electrical systems that when submerged in water may cause damage to the personal mobility device or wheelchair or may contaminate the pool water. Providing an aquatic wheelchair made of non-corrosive materials and designed for access into the water will protect the water from contamination and avoid damage to personal wheelchairs or other mobility aids.</p> <p><b>A15.8.6.3 Handrails.</b> Handrails on both sides of a sloped entry provides stability to both persons with mobility impairments and persons using wheelchairs. For safety reasons, a single handrail is permitted on sloped entries provided at wave action pools, leisure rivers, sand bottom pools, and other pools where user access is limited to one area.</p> <p><b>A15.8.8.4 Transfer Steps.</b> Where possible, the height of the transfer step should be as minimal as possible. This will decrease the distance an individual is required to lift up or move down to reach the next step to gain access.</p> <p><b>A15.8.8.7 Grab Bars.</b> Pool operators have the choice of providing a grab bar on one side of each step and transfer platform or a continuous grab bar on one side serving each transfer step and the transfer platform. If provided on each step, the top of the gripping surface must be 4 to 6 inches above each step. Where a continuous grab bar is provided, the top of the gripping surface must be 4 to 6 inches above the step nosing. Each type has its advantages. A continuous handrail allows the person that is transferring to maintain a constant grip on the handrail while moving up or down the transfer steps. Grab bars provided on each step provide the gripping surface parallel to each step rather than on a diagonal.</p> <p><b>A15.8.10 Water Play Components.</b> Personal wheelchairs and mobility devices may not be appropriate for submerging in water when accessing play components located in water.</p>	<p>Some may have batteries, motors, and electrical systems that when submerged in water may cause damage to the personal mobility device or wheelchair or may contaminate the water. Providing an aquatic wheelchair made of non-corrosive materials and designed for access into the water will protect the water from contamination and avoid damage to personal wheelchairs.</p>
---	---

**A32**

[56 FR 35453, July 26, 1991, as amended at 56 FR 45517, 45520, and 45526, Sept. 6, 1991, 57 FR 1393, 1396, Jan. 14, 1992; 58 FR 38206, July 15, 1993; 59 FR 31744, June 20, 1994; 63 FR 2016, 2071, Jan. 13, 1998; 65 FR 62511, Oct. 18, 2000; 65 FR 69841, Nov. 20, 2000; 67 FR 56384, Sept. 3, 2002]

**PART 1192—AMERICANS WITH DISABILITIES ACT (ADA) ACCESSIBILITY GUIDELINES FOR TRANSPORTATION VEHICLES**

**Subpart A—General**

Sec.

- 1192.1 Purpose.
- 1192.2 Equivalent facilitation.
- 1192.3 Definitions.
- 1192.4 Miscellaneous instructions.

**Subpart B—Buses, Vans and Systems**

- 1192.21 General.
- 1192.23 Mobility aid accessibility.
- 1192.25 Doors, steps and thresholds.
- 1192.27 Priority seating signs.
- 1192.29 Interior circulation, handrails and stanchions.
- 1192.31 Lighting.
- 1192.33 Fare box.
- 1192.35 Public information system.
- 1192.37 Stop request.
- 1192.39 Destination and route signs.

**Subpart C—Rapid Rail Vehicles and Systems**

- 1192.51 General.
- 1192.53 Doorways.
- 1192.55 Priority seating signs.
- 1192.57 Interior circulation, handrails and stanchions.
- 1192.59 Floor surfaces.
- 1192.61 Public information system.
- 1192.63 Between-car barriers.

**Subpart D—Light Rail Vehicles and Systems**

- 1192.71 General.
- 1192.73 Doorways.
- 1192.75 Priority seating signs.
- 1192.77 Interior circulation, handrails and stanchions.
- 1192.79 Floors, steps and thresholds.
- 1192.81 Lighting.
- 1192.83 Mobility aid accessibility.
- 1192.85 Between-car barriers.
- 1192.87 Public information system.

**Subpart E—Commuter Rail Cars and Systems**

- 1192.91 General.
- 1192.93 Doorways.
- 1192.95 Mobility aid accessibility.
- 1192.97 Interior circulation, handrails and stanchions.
- 1192.99 Floors, steps and thresholds.
- 1192.101 Lighting.
- 1192.103 Public information system.
- 1192.105 Priority seating signs.
- 1192.107 Restrooms.
- 1192.109 Between-car barriers.

**Subpart F—Intercity Rail Cars and Systems**

- 1192.111 General.
- 1192.113 Doorways.
- 1192.115 Interior circulation, handrails and stanchions.
- 1192.117 Floors, steps and thresholds.
- 1192.119 Lighting.
- 1192.121 Public information system.
- 1192.123 Restrooms.
- 1192.125 Mobility aid accessibility.
- 1192.127 Sleeping compartments.

**Subpart G—Over-the-Road Buses and Systems**

- 1192.151 General.
- 1192.153 Doors, steps and thresholds.
- 1192.155 Interior circulation, handrails and stanchions.
- 1192.157 Lighting.
- 1192.159 Mobility aid accessibility.
- 1192.161 Moveable aisle armrests.

**Subpart H—Other Vehicles and Systems**

- 1192.171 General.
- 1192.173 Automated guideway transit vehicles and systems.
- 1192.175 High-speed rail cars, monorails and systems.
- 1192.177 Ferries, excursion boats and other vessels. [Reserved]
- 1192.179 Trams, similar vehicles and systems.

FIGURES TO PART 1192

APPENDIX TO PART 1192—ADVISORY GUIDANCE

AUTHORITY: 42 U.S.C. 12204.

SOURCE: 56 FR 45558, Sept. 6, 1991, unless otherwise noted.

**Subpart A—General**

**§ 1192.1 Purpose.**

This part provides minimum guidelines and requirements for accessibility standards to be issued by the Department of Transportation in 49 CFR part 37 for transportation vehicles required to be accessible by the Americans with Disabilities Act (ADA) of 1990 (42 U.S.C. 12101 *et seq.*).

**§ 1192.2 Equivalent facilitation.**

Departures from particular technical and scoping requirements of these guidelines by use of other designs and technologies are permitted where the alternative designs and technologies used will provide substantially equivalent or greater access to and usability of the vehicle. Departures are to be considered on a case-by-case basis by

the Department of Transportation under the procedure set forth in 49 CFR 37.7.

### § 1192.3 Definitions.

*Accessible* means, with respect to vehicles covered by this part, compliance with the provisions of this part.

*Automated guideway transit (AGT) system* means a fixed-guideway transportation system which operates with automated (driverless) individual vehicles or multi-car trains. Service may be on a fixed schedule or in response to a passenger-activated call button. Such systems using small, slow moving vehicles, often operated in airports and amusement parks, are sometimes called *people movers*.

*Bus* means any of several types of self-propelled vehicles, other than an over-the-road bus, generally rubber tired, intended for use on city streets, highways, and busways, including but not limited to minibuses, forty- and thirty-foot transit buses, articulated buses, double-deck buses, and electric powered trolley buses, used to provide designated or specified public transportation services. Self-propelled, rubber tire vehicles designed to look like antique or vintage trolleys or streetcars are considered buses.

*Common wheelchairs and mobility aids* means belonging to a class of three or four wheeled devices, usable indoors, designed for and used by persons with mobility impairments which do not exceed 30 inches in width and 48 inches in length, measured 2 inches above the ground, and do not weigh more than 600 pounds when occupied.

*Commuter rail car* means a rail passenger car obtained by a commuter authority (as defined by 49 CFR 37.3) for use in commuter rail transportation.

*Commuter rail transportation* means short-haul rail passenger service operating in metropolitan and suburban areas, operated by a commuter authority, whether within or across the geographical boundaries of a state, usually characterized by reduced fare, multiple ride, and commutation tickets and by morning and evening peak period operations. This term does not include light or rapid rail transportation.

*Demand responsive system* means any system of transporting individuals, in-

cluding the provision of designated public transportation service by public entities and the provision of transportation service by private entities, including but not limited to specified public transportation service, which is not a fixed route system.

*Designated public transportation* means transportation provided by a public entity (other than public school transportation) by bus, rail, or other conveyance (other than transportation by aircraft or intercity or commuter rail transportation) that provides the general public with general or special service, including charter service, on a regular and continuing basis.

*Fixed route system* means a system of transporting individuals (other than by aircraft), including the provision of designated public transportation service by public entities and the provision of transportation service by private entities, including but not limited to specified public transportation service, on which a vehicle is operated along a prescribed route according to a fixed schedule.

*High speed rail* means an intercity-type rail service which operates primarily on a dedicated guideway or track not used, for the most part, by freight, including, but not limited to, trains on welded rail, magnetically levitated (maglev) vehicles on a special guideway, or other advanced technology vehicles, designed to travel at speeds in excess of those possible on other types of railroads.

*Intercity rail passenger car* means a rail car intended for use by revenue passengers obtained by the National Railroad Passenger Corporation (Amtrak) for use in intercity rail transportation.

*Intercity rail transportation* means transportation provided by Amtrak.

*Light rail* means a streetcar-type vehicle railway operated on city streets, semi-private rights-of-way, or exclusive private rights-of-way. Service may be provided by step-entry vehicles or by level-boarding.

*New vehicle* means a vehicle which is offered for sale or lease after manufacture without any prior use.

*Over-the-road bus* means a vehicle characterized by an elevated passenger

§ 1192.4

deck located over a baggage compartment.

*Rapid rail* means a subway-type transit vehicle railway operated on exclusive private rights-of-way with high-level platform stations. Rapid rail may also operate on elevated or at-grade level track separated from other traffic.

*Remanufactured vehicle* means a vehicle which has been structurally restored and has had new or rebuilt major components installed to extend its service life.

*Specified public transportation* means transportation by bus, rail, or any other conveyance (other than aircraft) provided by a private entity to the general public, with general or special service (including charter service) on a regular and continuing basis.

*Tram* means any of several types of motor vehicles consisting of a tractor unit, with or without passenger accommodations, and one or more passenger trailer units, including but not limited to vehicles providing shuttle service to remote parking areas, between hotels and other public accommodations, and between and within amusement parks and other recreation areas.

*Used vehicle* means a vehicle with prior use.

§ 1192.4 Miscellaneous instructions.

(a) *Dimensional conventions.* Dimensions that are not noted as minimum or maximum are absolute.

(b) *Dimensional tolerances.* All dimensions are subject to conventional engineering tolerances for material properties and field conditions, including normal anticipated wear not exceeding accepted industry-wide standards and practices.

(c) *Notes.* The text of these guidelines does not contain notes or footnotes. Additional information, explanations, and advisory materials are located in the appendix.

(d) *General terminology.* The terms used in this part shall have the following meanings:

(1) *Comply with* means meet one or more specification of these guidelines.

(2) *If or if \* \* \* then* denotes a specification that applies only when the conditions described are present.

(3) *May* denotes an option or alternative.

(4) *Shall* denotes a mandatory specification or requirement.

(5) *Should* denotes an advisory specification or recommendation and is used only in the appendix to this part.

Subpart B—Buses, Vans and Systems

§ 1192.21 General.

(a) New, used or remanufactured buses and vans (except over-the-road buses covered by subpart G of this part), to be considered accessible by regulations issued by the Department of Transportation in 49 CFR part 37, shall comply with the applicable provisions of this subpart.

(b) If portions of the vehicle are modified in a way that affects or could affect accessibility, each such portion shall comply, to the extent practicable, with the applicable provisions of this subpart. This provision does not require that inaccessible buses be retrofitted with lifts, ramps or other boarding devices.

§ 1192.23 Mobility aid accessibility.

(a) *General.* All vehicles covered by this subpart shall provide a level-change mechanism or boarding device (e.g., lift or ramp) complying with paragraph (b) or (c) of this section and sufficient clearances to permit a wheelchair or other mobility aid user to reach a securement location. At least two securement locations and devices, complying with paragraph (d) of this section, shall be provided on vehicles in excess of 22 feet in length; at least one securement location and device, complying with paragraph (d) of this section, shall be provided on vehicles 22 feet in length or less.

(b) *Vehicle lift*—(1) *Design load.* The design load of the lift shall be at least 600 pounds. Working parts, such as cables, pulleys, and shafts, which can be expected to wear, and upon which the lift depends for support of the load, shall have a safety factor of at least six, based on the ultimate strength of the material. Nonworking parts, such as platform, frame, and attachment hardware which would not be expected to wear, shall have a safety factor of at



least three, based on the ultimate strength of the material.

(2) *Controls*—(i) *Requirements*. The controls shall be interlocked with the vehicle brakes, transmission, or door, or shall provide other appropriate mechanisms or systems, to ensure that the vehicle cannot be moved when the lift is not stowed and so the lift cannot be deployed unless the interlocks or systems are engaged. The lift shall deploy to all levels (i.e., ground, curb, and intermediate positions) normally encountered in the operating environment. Where provided, each control for deploying, lowering, raising, and stowing the lift and lowering the roll-off barrier shall be of a momentary contact type requiring continuous manual pressure by the operator and shall not allow improper lift sequencing when the lift platform is occupied. The controls shall allow reversal of the lift operation sequence, such as raising or lowering a platform that is part way down, without allowing an occupied platform to fold or retract into the stowed position.

(ii) *Exception*. Where the lift is designed to deploy with its long dimension parallel to the vehicle axis and which pivots into or out of the vehicle while occupied (i.e., *rotary lift*), the requirements of this paragraph prohibiting the lift from being stowed while occupied shall not apply if the stowed position is within the passenger compartment and the lift is intended to be stowed while occupied.

(3) *Emergency operation*. The lift shall incorporate an emergency method of deploying, lowering to ground level with a lift occupant, and raising and stowing the empty lift if the power to the lift fails. No emergency method, manual or otherwise, shall be capable of being operated in a manner that could be hazardous to the lift occupant or to the operator when operated according to manufacturer's instructions, and shall not permit the platform to be stowed or folded when occupied, unless the lift is a rotary lift and is intended to be stowed while occupied.

(4) *Power or equipment failure*. Platforms stowed in a vertical position, and deployed platforms when occupied, shall have provisions to prevent their deploying, falling, or folding any faster

than 12 inches/second or their dropping of an occupant in the event of a single failure of any load carrying component.

(5) *Platform barriers*. The lift platform shall be equipped with barriers to prevent any of the wheels of a wheelchair or mobility aid from rolling off the platform during its operation. A movable barrier or inherent design feature shall prevent a wheelchair or mobility aid from rolling off the edge closest to the vehicle until the platform is in its fully raised position. Each side of the lift platform which extends beyond the vehicle in its raised position shall have a barrier a minimum 1½ inches high. Such barriers shall not interfere with maneuvering into or out of the aisle. The loading-edge barrier (outer barrier) which functions as a loading ramp when the lift is at ground level, shall be sufficient when raised or closed, or a supplementary system shall be provided, to prevent a power wheelchair or mobility aid from riding over or defeating it. The outer barrier of the lift shall automatically raise or close, or a supplementary system shall automatically engage, and remain raised, closed, or engaged at all times that the platform is more than 3 inches above the roadway or sidewalk and the platform is occupied. Alternatively, a barrier or system may be raised, lowered, opened, closed, engaged, or disengaged by the lift operator, provided an interlock or inherent design feature prevents the lift from rising unless the barrier is raised or closed or the supplementary system is engaged.

(6) *Platform surface*. The platform surface shall be free of any protrusions over ¼ inch high and shall be slip resistant. The platform shall have a minimum clear width of 28½ inches at the platform, a minimum clear width of 30 inches measured from 2 inches above the platform surface to 30 inches above the platform, and a minimum clear length of 48 inches measured from 2 inches above the surface of the platform to 30 inches above the surface of the platform. (See Fig. 1)

(7) *Platform gaps*. Any openings between the platform surface and the raised barriers shall not exceed ⅝ inch in width. When the platform is at vehicle floor height with the inner barrier

(if applicable) down or retracted, gaps between the forward lift platform edge and the vehicle floor shall not exceed ½ inch horizontally and ⅝ inch vertically. Platforms on semi-automatic lifts may have a hand hold not exceeding 1½ inches by 4½ inches located between the edge barriers.

(8) *Platform entrance ramp.* The entrance ramp, or loading-edge barrier used as a ramp, shall not exceed a slope of 1:8, measured on level ground, for a maximum rise of 3 inches, and the transition from roadway or sidewalk to ramp may be vertical without edge treatment up to ¼ inch. Thresholds between ¼ inch and ½ inch high shall be beveled with a slope no greater than 1:2.

(9) *Platform deflection.* The lift platform (not including the entrance ramp) shall not deflect more than 3 degrees (exclusive of vehicle roll or pitch) in any direction between its unloaded position and its position when loaded with 600 pounds applied through a 26 inch by 26 inch test pallet at the centroid of the platform.

(10) *Platform movement.* No part of the platform shall move at a rate exceeding 6 inches/second during lowering and lifting an occupant, and shall not exceed 12 inches/second during deploying or stowing. This requirement does not apply to the deployment or stowage cycles of lifts that are manually deployed or stowed. The maximum platform horizontal and vertical acceleration when occupied shall be 0.3g.

(11) *Boarding direction.* The lift shall permit both inboard and outboard facing of wheelchair and mobility aid users.

(12) *Use by standees.* Lifts shall accommodate persons using walkers, crutches, canes or braces or who otherwise have difficulty using steps. The platform may be marked to indicate a preferred standing position.

(13) *Handrails.* Platforms on lifts shall be equipped with handrails on two sides, which move in tandem with the lift, and which shall be graspable and provide support to standees throughout the entire lift operation. Handrails shall have a usable component at least 8 inches long with the lowest portion a minimum 30 inches above the platform and the highest portion a maximum 80

inches above the platform. The handrails shall be capable of withstanding a force of 100 pounds concentrated at any point on the handrail without permanent deformation of the rail or its supporting structure. The handrail shall have a cross-sectional diameter between 1¼ inches and 1½ inches or shall provide an equivalent grasping surface, and have eased edges with corner radii of not less than ⅛ inch. Handrails shall be placed to provide a minimum 1½ inches knuckle clearance from the nearest adjacent surface. Handrails shall not interfere with wheelchair or mobility aid maneuverability when entering or leaving the vehicle.

(c) *Vehicle ramp—(1) Design load.* Ramps 30 inches or longer shall support a load of 600 pounds, placed at the centroid of the ramp distributed over an area of 26 inches by 26 inches, with a safety factor of at least 3 based on the ultimate strength of the material. Ramps shorter than 30 inches shall support a load of 300 pounds.

(2) *Ramp surface.* The ramp surface shall be continuous and slip resistant; shall not have protrusions from the surface greater than ¼ inch high; shall have a clear width of 30 inches; and shall accommodate both four-wheel and three-wheel mobility aids.

(3) *Ramp threshold.* The transition from roadway or sidewalk and the transition from vehicle floor to the ramp may be vertical without edge treatment up to ¼ inch. Changes in level between ¼ inch and ½ inch shall be beveled with a slope no greater than 1:2.

(4) *Ramp barriers.* Each side of the ramp shall have barriers at least 2 inches high to prevent mobility aid wheels from slipping off.

(5) *Slope.* Ramps shall have the least slope practicable and shall not exceed 1:4 when deployed to ground level. If the height of the vehicle floor from which the ramp is deployed is 3 inches or less above a 6-inch curb, a maximum slope of 1:4 is permitted; if the height of the vehicle floor from which the ramp is deployed is 6 inches or less, but greater than 3 inches, above a 6-inch curb, a maximum slope of 1:6 is permitted; if the height of the vehicle floor from which the ramp is deployed is 9 inches or less, but greater than 6

inches, above a 6-inch curb, a maximum slope of 1:8 is permitted; if the height of the vehicle floor from which the ramp is deployed is greater than 9 inches above a 6-inch curb, a slope of 1:12 shall be achieved. Folding or telescoping ramps are permitted provided they meet all structural requirements of this section.

(6) *Attachment.* When in use for boarding or alighting, the ramp shall be firmly attached to the vehicle so that it is not subject to displacement when loading or unloading a heavy power mobility aid and that no gap between vehicle and ramp exceeds  $\frac{5}{8}$  inch.

(7) *Stowage.* A compartment, securement system, or other appropriate method shall be provided to ensure that stowed ramps, including portable ramps stowed in the passenger area, do not impinge on a passenger's wheelchair or mobility aid or pose any hazard to passengers in the event of a sudden stop or maneuver.

(8) *Handrails.* If provided, handrails shall allow persons with disabilities to grasp them from outside the vehicle while starting to board, and to continue to use them throughout the boarding process, and shall have the top between 30 inches and 38 inches above the ramp surface. The handrails shall be capable of withstanding a force of 100 pounds concentrated at any point on the handrail without permanent deformation of the rail or its supporting structure. The handrail shall have a cross-sectional diameter between  $1\frac{1}{4}$  inches and  $1\frac{1}{2}$  inches or shall provide an equivalent grasping surface, and have eased edges with corner radii of not less than  $\frac{1}{8}$  inch. Handrails shall not interfere with wheelchair or mobility aid maneuverability when entering or leaving the vehicle.

(d) *Securement devices—(1) Design load.* Securement systems on vehicles with GVWRs of 30,000 pounds or above, and their attachments to such vehicles, shall restrain a force in the forward longitudinal direction of up to 2,000 pounds per securement leg or clamping mechanism and a minimum of 4,000 pounds for each mobility aid. Securement systems on vehicles with GVWRs of up to 30,000 pounds, and their attachments to such vehicles, shall restrain a force in the forward longitudinal direc-

tion of up to 2,500 pounds per securement leg or clamping mechanism and a minimum of 5,000 pounds for each mobility aid.

(2) *Location and size.* The securement system shall be placed as near to the accessible entrance as practicable and shall have a clear floor area of 30 inches by 48 inches. Such space shall adjoin, and may overlap, an access path. Not more than 6 inches of the required clear floor space may be accommodated for footrests under another seat provided there is a minimum of 9 inches from the floor to the lowest part of the seat overhanging the space. Securement areas may have fold-down seats to accommodate other passengers when a wheelchair or mobility aid is not occupying the area, provided the seats, when folded up, do not obstruct the clear floor space required. (See Fig. 2)

(3) *Mobility aids accommodated.* The securement system shall secure common wheelchairs and mobility aids and shall either be automatic or easily attached by a person familiar with the system and mobility aid and having average dexterity.

(4) *Orientation.* In vehicles in excess of 22 feet in length, at least one securement device or system required by paragraph (a) of this section shall secure the wheelchair or mobility aid facing toward the front of the vehicle. In vehicles 22 feet in length or less, the required securement device may secure the wheelchair or mobility aid either facing toward the front of the vehicle or rearward. Additional securement devices or systems shall secure the wheelchair or mobility aid facing forward or rearward. Where the wheelchair or mobility aid is secured facing the rear of the vehicle, a padded barrier shall be provided. The padded barrier shall extend from a height of 38 inches from the vehicle floor to a height of 56 inches from the vehicle floor with a width of 18 inches, laterally centered immediately in back of the seated individual. Such barriers need not be solid provided equivalent protection is afforded.

(5) *Movement.* When the wheelchair or mobility aid is secured in accordance with manufacturer's instructions, the securement system shall limit the

## § 1192.25

movement of an occupied wheelchair or mobility aid to no more than 2 inches in any direction under normal vehicle operating conditions.

(6) *Stowage.* When not being used for securement, or when the securement area can be used by standees, the securement system shall not interfere with passenger movement, shall not present any hazardous condition, shall be reasonably protected from vandalism, and shall be readily accessed when needed for use.

(7) *Seat belt and shoulder harness.* For each wheelchair or mobility aid securement device provided, a passenger seat belt and shoulder harness, complying with all applicable provisions of 49 CFR part 571, shall also be provided for use by wheelchair or mobility aid users. Such seat belts and shoulder harnesses shall not be used in lieu of a device which secures the wheelchair or mobility aid itself.

## § 1192.25 Doors, steps and thresholds.

(a) *Slip resistance.* All aisles, steps, floor areas where people walk and floors in securement locations shall have slip-resistant surfaces.

(b) *Contrast.* All step edges, thresholds, and the boarding edge of ramps or lift platforms shall have a band of color(s) running the full width of the step or edge which contrasts from the step tread and riser, or lift or ramp surface, either light-on-dark or dark-on-light.

(c) *Door height.* For vehicles in excess of 22 feet in length, the overhead clearance between the top of the door opening and the raised lift platform, or highest point of a ramp, shall be a minimum of 68 inches. For vehicles of 22 feet in length or less, the overhead clearance between the top of the door opening and the raised lift platform, or highest point of a ramp, shall be a minimum of 56 inches.

## § 1192.27 Priority seating signs.

(a) Each vehicle shall contain sign(s) which indicate that seats in the front of the vehicle are priority seats for persons with disabilities, and that other passengers should make such seats available to those who wish to use them. At least one set of forward-facing seats shall be so designated.

## 36 CFR Ch. XI (7-1-03 Edition)

(b) Each securement location shall have a sign designating it as such.

(c) Characters on signs required by paragraphs (a) and (b) of this section shall have a width-to-height ratio between 3:5 and 1:1 and a stroke width-to-height ratio between 1:5 and 1:10, with a minimum character height (using an upper case "X") of  $\frac{5}{8}$  inch, with "wide" spacing (generally, the space between letters shall be  $\frac{1}{16}$  the height of upper case letters), and shall contrast with the background either light-on-dark or dark-on-light.

## § 1192.29 Interior circulation, handrails and stanchions.

(a) Interior handrails and stanchions shall permit sufficient turning and maneuvering space for wheelchairs and other mobility aids to reach a securement location from the lift or ramp.

(b) Handrails and stanchions shall be provided in the entrance to the vehicle in a configuration which allows persons with disabilities to grasp such assists from outside the vehicle while starting to board, and to continue using such assists throughout the boarding and fare collection process. Handrails shall have a cross-sectional diameter between  $1\frac{1}{4}$  inches and  $1\frac{1}{2}$  inches or shall provide an equivalent grasping surface, and have eased edges with corner radii of not less than  $\frac{1}{8}$  inch. Handrails shall be placed to provide a minimum  $1\frac{1}{2}$  inches knuckle clearance from the nearest adjacent surface. Where on-board fare collection devices are used on vehicles in excess of 22 feet in length, a horizontal passenger assist shall be located across the front of the vehicle and shall prevent passengers from sustaining injuries on the fare collection device or windshield in the event of a sudden deceleration. Without restricting the vestibule space, the assist shall provide support for a boarding passenger from the front door through the boarding procedure. Passengers shall be able to lean against the assist for security while paying fares.

(c) For vehicles in excess of 22 feet in length, overhead handrail(s) shall be provided which shall be continuous except for a gap at the rear doorway.

(d) Handrails and stanchions shall be sufficient to permit safe boarding, on-

board circulation, seating and standing assistance, and alighting by persons with disabilities.

(e) For vehicles in excess of 22 feet in length with front-door lifts or ramps, vertical stanchions immediately behind the driver shall either terminate at the lower edge of the aisle-facing seats, if applicable, or be "dog-legged" so that the floor attachment does not impede or interfere with wheelchair footrests. If the driver seat platform must be passed by a wheelchair or mobility aid user entering the vehicle, the platform, to the maximum extent practicable, shall not extend into the aisle or vestibule beyond the wheel housing.

(f) For vehicles in excess of 22 feet in length, the minimum interior height along the path from the lift to the securement location shall be 68 inches. For vehicles of 22 feet in length or less, the minimum interior height from lift to securement location shall be 56 inches.

#### § 1192.31 Lighting.

(a) Any stepwell or doorway immediately adjacent to the driver shall have, when the door is open, at least 2 foot-candles of illumination measured on the step tread or lift platform.

(b) Other stepwells and doorways, including doorways in which lifts or ramps are installed, shall have, at all times, at least 2 foot-candles of illumination measured on the step tread, or lift or ramp, when deployed at the vehicle floor level.

(c) The vehicle doorways, including doorways in which lifts or ramps are installed, shall have outside light(s) which, when the door is open, provide at least 1 foot-candle of illumination on the street surface for a distance 3 feet (915 mm) perpendicular to the bottom step tread or lift outer edge. Such light(s) shall be shielded to protect the eyes of entering and exiting passengers.

[56 FR 45558, Sept. 6, 1991, as amended at 63 FR 51697, 51702, Sept. 28, 1998]

#### § 1192.33 Fare box.

Where provided, the farebox shall be located as far forward as practicable and shall not obstruct traffic in the

vestibule, especially wheelchairs or mobility aids.

#### § 1192.35 Public information system.

(a) Vehicles in excess of 22 feet in length, used in multiple-stop, fixed-route service, shall be equipped with a public address system permitting the driver, or recorded or digitized human speech messages, to announce stops and provide other passenger information within the vehicle.

(b) [Reserved]

#### § 1192.37 Stop request.

(a) Where passengers may board or alight at multiple stops at their option, vehicles in excess of 22 feet in length shall provide controls adjacent to the securement location for requesting stops and which alerts the driver that a mobility aid user wishes to disembark. Such a system shall provide auditory and visual indications that the request has been made.

(b) Controls required by paragraph (a) of this section shall be mounted no higher than 48 inches and no lower than 15 inches above the floor, shall be operable with one hand and shall not require tight grasping, pinching, or twisting of the wrist. The force required to activate controls shall be no greater than 5 lbf (22.2 N).

#### § 1192.39 Destination and route signs.

(a) Where destination or route information is displayed on the exterior of a vehicle, each vehicle shall have illuminated signs on the front and boarding side of the vehicle.

(b) Characters on signs required by paragraph (a) of this section shall have a width-to-height ratio between 3:5 and 1:1 and a stroke width-to-height ratio between 1:5 and 1:10, with a minimum character height (using an upper case "X") of 1 inch for signs on the boarding side and a minimum character height of 2 inches for front "heads signs", with "wide" spacing (generally, the space between letters shall be  $\frac{1}{16}$  the height of upper case letters), and shall contrast with the background, either dark-on-light or light-on-dark.

### Subpart C—Rapid Rail Vehicles and Systems

#### § 1192.51 General.

(a) New, used and remanufactured rapid rail vehicles, to be considered accessible by regulations issued by the Department of Transportation in 49 CFR part 37, shall comply with this subpart.

(b) If portions of the vehicle are modified in a way that affects or could affect accessibility, each such portion shall comply, to the extent practicable, with the applicable provisions of this subpart. This provision does not require that inaccessible vehicles be retrofitted with lifts, ramps or other boarding devices.

(c) Existing vehicles which are retrofitted to comply with the "one-car-per-train rule" of 49 CFR 37.93 shall comply with §§ 1192.55, 1192.57(b), 1192.59 and shall have, in new and key stations, at least one door complying with § 1192.53(a)(1), (b) and (d). Removal of seats is not required. Vehicles previously designed and manufactured in accordance with the accessibility requirements of 49 CFR part 609 or Department of Transportation regulations implementing section 504 of the Rehabilitation Act of 1973 that were in effect before October 7, 1991, and which can be entered and used from stations in which they are to be operated, may be used to satisfy the requirements of 49 CFR 37.93.

#### § 1192.53 Doorways.

(a) *Clear width.* (1) Passenger doorways on vehicle sides shall have clear openings at least 32 inches wide when open.

(2) If doorways connecting adjoining cars in a multi-car train are provided, and if such doorway is connected by an aisle with a minimum clear width of 30 inches to one or more spaces where wheelchair or mobility aid users can be accommodated, then such doorway shall have a minimum clear opening of 30 inches to permit wheelchair and mobility aid users to be evacuated to an adjoining vehicle in an emergency.

(b) *Signage.* The International Symbol of Accessibility shall be displayed on the exterior of accessible vehicles operating on an accessible and rapid

rail system unless all vehicles area accessible and are not marked by the access symbol. (See Fig. 6)

(c) *Signals.* Auditory and visual warning signals shall be provided to alert passengers of closing doors.

(d) *Coordination with boarding platform—(1) Requirements.* Where new vehicles will operate in new stations, the design of vehicles shall be coordinated with the boarding platform design such that the horizontal gap between each vehicle door at rest and the platform shall be no greater than 3 inches and the height of the vehicle floor shall be within plus or minus  $\frac{5}{8}$  inch of the platform height under all normal passenger load conditions. Vertical alignment may be accomplished by vehicle air suspension or other suitable means of meeting the requirement.

(2) *Exception.* New vehicles operating in existing stations may have a floor height within plus or minus  $1\frac{1}{2}$  inches of the platform height. At key stations, the horizontal gap between at least one door of each such vehicle and the platform shall be no greater than 3 inches.

(3) *Exception.* Retrofitted vehicles shall be coordinated with the platform in new and key stations such that the horizontal gap shall be no greater than 4 inches and the height of the vehicle floor, under 50% passenger load, shall be within plus or minus 2 inches of the platform height.

#### § 1192.55 Priority seating signs.

(a) Each vehicle shall contain sign(s) which indicate that certain seats are priority seats for persons with disabilities, and that other passengers should make such seats available to those who wish to use them.

(b) Characters on signs required by paragraph (a) of this section shall have a width-to-height ratio between 3:5 and 1:1 and a stroke width-to-height ratio between 1:5 and 1:10, with a minimum character height (using an upper case "X") of  $\frac{5}{8}$  inch, with "Wide" spacing (generally, the space between letters shall be  $\frac{1}{16}$  the height of upper case letters), and shall contrast with the background, either light-on-dark or dark-on-light.

**§ 1192.57 Interior circulation, handrails and stanchions.**

(a) Handrails and stanchions shall be provided to assist safe boarding, on-board circulation, seating and standing assistance, and alighting by persons with disabilities.

(b) Handrails, stanchions, and seats shall allow a route at least 32 inches wide so that at least two wheelchair or mobility aid users can enter the vehicle and position the wheelchairs or mobility aids in areas, each having a minimum clear space of 48 inches by 30 inches, which do not unduly restrict movement of other passengers. Space to accommodate wheelchairs and mobility aids may be provided within the normal area used by standees and designation of specific spaces is not required. Particular attention shall be given to ensuring maximum maneuverability immediately inside doors. Ample vertical stanchions from ceiling to seat-back rails shall be provided. Vertical stanchions from ceiling to floor shall not interfere with wheelchair or mobility aid user circulation and shall be kept to a minimum in the vicinity of doors.

(c) The diameter or width of the gripping surface of handrails and stanchions shall be 1¼ inches to 1½ inches or provide an equivalent gripping surface and shall provide a minimum 1½ inches knuckle clearance from the nearest adjacent surface.

**§ 1192.59 Floor surfaces.**

Floor surfaces on aisles, places for standees, and areas where wheelchair and mobility aid users are to be accommodated shall be slip-resistant.

**§ 1192.61 Public information system.**

(a)(1) *Requirements.* Each vehicle shall be equipped with a public address system permitting transportation system personnel, or recorded or digitized human speech messages, to announce stations and provide other passenger information. Alternative systems or devices which provide equivalent access are also permitted. Each vehicle operating in stations having more than one line or route shall have an external public address system to permit transportation system personnel, or recorded or digitized human speech mes-

sages, to announce train, route, or line identification information.

(2) *Exception.* Where station announcement systems provide information on arriving trains, an external train speaker is not required.

(b) [Reserved]

**§ 1192.63 Between-car barriers.**

(a) *Requirement.* Suitable devices or systems shall be provided to prevent, deter or warn individuals from inadvertently stepping off the platform between cars. Acceptable solutions include, but are not limited to, pantograph gates, chains, motion detectors or similar devices.

(b) *Exception.* Between-car barriers are not required where platform screens are provided which close off the platform edge and open only when trains are correctly aligned with the doors.

**Subpart D—Light Rail Vehicles and Systems****§ 1192.71 General.**

(a) New, used and remanufactured light rail vehicles, to be considered accessible by regulations issued by the Department of Transportation in 49 CFR part 37, shall comply with this subpart.

(b)(1) Vehicles intended to be operated solely in light rail systems confined entirely to a dedicated right-of-way, and for which all stations or stops are designed and constructed for revenue service after the effective date of standards for design and construction issued pursuant to subpart C of 49 CFR part 37, shall provide level boarding and shall comply with §§ 1192.73(d)(1) and 1192.85.

(2) Vehicles designed for, and operated on, pedestrian malls, city streets, or other areas where level boarding is not practicable shall provide wayside or car-borne lifts, mini-high platforms, or other means of access in compliance with § 1192.83 (b) or (c).

(c) If portions of the vehicle are modified in a way that affects or could affect accessibility, each such portion shall comply, to the extent practicable, with the applicable provisions of this

## § 1192.73

## 36 CFR Ch. XI (7–1–03 Edition)

subpart. This provision does not require that inaccessible vehicles be retrofitted with lifts, ramps or other boarding devices.

(d) Existing vehicles retrofitted to comply with the “one-car-per-train rule” at 49 CFR 37.93 shall comply with §§ 1192.75, 1192.77(c), 1192.79(a) and 1192.83(a) and shall have, in new and key stations, at least one door which complies with § 1192.73 (a)(1), (b) and (d). Vehicles previously designed and manufactured in accordance with the accessibility requirements of 49 CFR part 609 or Department of Transportation regulations implementing section 504 of the Rehabilitation Act of 1973 that were in effect before October 7, 1991, and which can be entered and used from stations in which they are to be operated, may be used to satisfy the requirements of 49 CFR 37.93.

### § 1192.73 Doorways.

(a) *Clear width.* (1) All passenger doorways on vehicle sides shall have minimum clear openings of 32 inches when open.

(2) If doorways connecting adjoining cars in a multi-car train are provided, and if such doorway is connected by an aisle with a minimum clear width of 30 inches to one or more spaces where wheelchair or mobility aid users can be accommodated, then such doorway shall have a minimum clear opening of 30 inches to permit wheelchair and mobility aid users to be evacuated to an adjoining vehicle in an emergency.

(b) *Signage.* The International Symbol of Accessibility shall be displayed on the exterior of each vehicle operating on an accessible light rail system unless all vehicles are accessible and are not marked by the access symbol (See Fig. 6).

(c) *Signals.* Auditory and visual warning signals shall be provided to alert passengers of closing doors.

(d) *Coordination with boarding platform—(1) Requirements.* The design of level-entry vehicles shall be coordinated with the boarding platform or mini-high platform design so that the horizontal gap between a vehicle at rest and the platform shall be no greater than 3 inches and the height of the vehicle floor shall be within plus or

minus  $\frac{5}{8}$  inch of the platform height. Vertical alignment may be accomplished by vehicle air suspension, automatic ramps or lifts, or any combination.

(2) *Exception.* New vehicles operating in existing stations may have a floor height within plus or minus  $1\frac{1}{2}$  inches of the platform height. At key stations, the horizontal gap between at least one door of each such vehicle and the platform shall be no greater than 3 inches.

(3) *Exception.* Retrofitted vehicles shall be coordinated with the platform in new and key stations such that the horizontal gap shall be no greater than 4 inches and the height of the vehicle floor, under 50% passenger load, shall be within plus or minus 2 inches of the platform height.

(4) *Exception.* Where it is not operationally or structurally practicable to meet the horizontal or vertical requirements of paragraphs (d) (1), (2) or (3) of this section, platform or vehicle devices complying with § 1192.83(b) or platform or vehicle mounted ramps or bridge plates complying with § 1192.83(c) shall be provided.

### § 1192.75 Priority seating signs.

(a) Each vehicle shall contain sign(s) which indicate that certain seats are priority seats for persons with disabilities, and that other passengers should make such seats available to those who wish to use them.

(b) Where designated wheelchair or mobility aid seating locations are provided, signs shall indicate the location and advise other passengers of the need to permit wheelchair and mobility aid users to occupy them.

(c) Characters on signs required by paragraph (a) or (b) of this section shall have a width-to-height ratio between 3:5 and 1:1 and a stroke width-to-height ratio between 1:5 and 1:10, with a minimum character height (using an upper case “X”) of  $\frac{5}{8}$  inch, with “wide” spacing (generally, the space between letters shall be  $\frac{1}{16}$  the height of upper case letters), and shall contrast with the background, either light-on-dark or dark-on-light.



**§ 1192.77 Interior circulation, handrails and stanchions.**

(a) Handrails and stanchions shall be sufficient to permit safe boarding, on-board circulation, seating and standing assistance, and alighting by persons with disabilities.

(b) At entrances equipped with steps, handrails and stanchions shall be provided in the entrance to the vehicle in a configuration which allows passengers to grasp such assists from outside the vehicle while starting to board, and to continue using such handrails or stanchions throughout the boarding process. Handrails shall have a cross-sectional diameter between 1¼ inches and 1½ inches or shall provide an equivalent grasping surface, and have eased edges with corner radii of not less than ⅛ inch. Handrails shall be placed to provide a minimum 1½ inches knuckle clearance from the nearest adjacent surface. Where on-board fare collection devices are used, a horizontal passenger assist shall be located between boarding passengers and the fare collection device and shall prevent passengers from sustaining injuries on the fare collection device or windshield in the event of a sudden deceleration. Without restricting the vestibule space, the assist shall provide support for a boarding passenger from the door through the boarding procedure. Passengers shall be able to lean against the assist for security while paying fares.

(c) At all doors on level-entry vehicles, and at each entrance accessible by lift, ramp, bridge plate or other suitable means, handrails, stanchions, passenger seats, vehicle driver seat platforms, and fare boxes, if applicable, shall be located so as to allow a route at least 32 inches wide so that at least two wheelchair or mobility aid users can enter the vehicle and position the wheelchairs or mobility aids in areas, each having a minimum clear space of 48 inches by 30 inches, which do not unduly restrict movement of other passengers. Space to accommodate wheelchairs and mobility aids may be provided within the normal area used by standees and designation of specific spaces is not required. Particular attention shall be given to ensuring maximum maneuverability immediately

inside doors. Ample vertical stanchions from ceiling to seat-back rails shall be provided. Vertical stanchions from ceiling to floor shall not interfere with wheelchair or mobility aid circulation and shall be kept to a minimum in the vicinity of accessible doors.

**§ 1192.79 Floors, steps and thresholds.**

(a) Floor surfaces on aisles, step treads, places for standees, and areas where wheelchair and mobility aid users are to be accommodated shall be slip-resistant.

(b) All thresholds and step edges shall have a band of color(s) running the full width of the step or threshold which contrasts from the step tread and riser or adjacent floor, either light-on-dark or dark-on-light.

**§ 1192.81 Lighting.**

(a) Any stepwell or doorway with a lift, ramp or bridge plate immediately adjacent to the driver shall have, when the door is open, at least 2 footcandles of illumination measured on the step tread or lift platform.

(b) Other stepwells, and doorways with lifts, ramps or bridge plates, shall have, at all times, at least 2 footcandles of illumination measured on the step tread or lift or ramp, when deployed at the vehicle floor level.

(c) The doorways of vehicles not operating at lighted station platforms shall have outside lights which provide at least 1 footcandle of illumination on the station platform or street surface for a distance of 3 feet perpendicular to all points on the bottom step tread. Such lights shall be located below window level and shielded to protect the eyes of entering and exiting passengers.

**§ 1192.83 Mobility aid accessibility.**

(a)(1) *General.* All new light rail vehicles, other than level entry vehicles, covered by this subpart shall provide a level-change mechanism or boarding device (e.g., lift, ramp or bridge plate) complying with either paragraph (b) or (c) of this section and sufficient clearances to permit at least two wheelchair or mobility aid users to reach areas, each with a minimum clear space of 48 inches by 30 inches, which do not unduly restrict passenger flow. Space

to accommodate wheelchairs and mobility aids may be provided within the normal area used by standees and designation of specific spaces is not required.

(2) *Exception.* If lifts, ramps or bridge plates meeting the requirements of this section are provided on station platforms or other stops, or mini-high platforms complying with § 1192.73(d) are provided, at stations or stops required to be accessible by 49 CFR part 37, the vehicle is not required to be equipped with a car-borne device. Where each new vehicle is compatible with a single platform-mounted access system or device, additional systems or devices are not required for each vehicle provided that the single device could be used to provide access to each new vehicle if passengers using wheelchairs or mobility aids could not be accommodated on a single vehicle.

(b) *Vehicle lift*—(1) *Design load.* The design load of the lift shall be at least 600 pounds. Working parts, such as cables, pulleys, and shafts, which can be expected to wear, and upon which the lift depends for support of the load, shall have a safety factor of at least six, based on the ultimate strength of the material. Nonworking parts, such as platform, frame, and attachment hardware which would not be expected to wear, shall have a safety factor of at least three, based on the ultimate strength of the material.

(2) *Controls*—(i) *Requirements.* The controls shall be interlocked with the vehicle brakes, propulsion system, or door, or shall provide other appropriate mechanisms or systems, to ensure that the vehicle cannot be moved when the lift is not stowed and so the lift cannot be deployed unless the interlocks or systems are engaged. The lift shall deploy to all levels (i.e., ground, curb, and intermediate positions) normally encountered in the operating environment. Where provided, each control for deploying, lowering, raising, and stowing the lift and lowering the roll-off barrier shall be of a momentary contact type requiring continuous manual pressure by the operator and shall not allow improper lift sequencing when the lift platform is occupied. The controls shall allow reversal of the lift operation sequence, such as raising or

lowering a platform that is part way down, without allowing an occupied platform to fold or retract into the stowed position.

(ii) *Exception.* Where physical or safety constraints prevent the deployment at some stops of a lift having its long dimension perpendicular to the vehicle axis, the transportation entity may specify a lift which is designed to deploy with its long dimension parallel to the vehicle axis and which pivots into or out of the vehicle while occupied (i.e., “rotary lift”). The requirements of paragraph (b)(2)(i) of this section prohibiting the lift from being stowed while occupied shall not apply to a lift design of this type if the stowed position is within the passenger compartment and the lift is intended to be stowed while occupied.

(iii) *Exception.* The brake or propulsion system interlocks requirement does not apply to a station platform mounted lift provided that a mechanical, electrical or other system operates to ensure that vehicles do not move when the lift is in use.

(3) *Emergency operation.* The lift shall incorporate an emergency method of deploying, lowering to ground level with a lift occupant, and raising and stowing the empty lift if the power to the lift fails. No emergency method, manual or otherwise, shall be capable of being operated in a manner that could be hazardous to the lift occupant or to the operator when operated according to manufacturer’s instructions, and shall not permit the platform to be stowed or folded when occupied, unless the lift is a rotary lift intended to be stowed while occupied.

(4) *Power or equipment failure.* Lift platforms stowed in a vertical position, and deployed platforms when occupied, shall have provisions to prevent their deploying, falling, or folding any faster than 12 inches/second or their dropping of an occupant in the event of a single failure of any load carrying component.

(5) *Platform barriers.* The lift platform shall be equipped with barriers to prevent any of the wheels of a wheelchair or mobility aid from rolling off the lift during its operation. A movable barrier or inherent design feature shall prevent a wheelchair or mobility aid from

rolling off the edge closest to the vehicle until the lift is in its fully raised position. Each side of the lift platform which extends beyond the vehicle in its raised position shall have a barrier a minimum 1½ inches high. Such barriers shall not interfere with maneuvering into or out of the aisle. The loading-edge barrier (outer barrier) which functions as a loading ramp when the lift is at ground level, shall be sufficient when raised or closed, or a supplementary system shall be provided, to prevent a power wheelchair or mobility aid from riding over or defeating it. The outer barrier of the lift shall automatically rise or close, or a supplementary system shall automatically engage, and remain raised, closed, or engaged at all times that the lift is more than 3 inches above the station platform or roadway and the lift is occupied. Alternatively, a barrier or system may be raised, lowered, opened, closed, engaged or disengaged by the lift operator provided an interlock or inherent design feature prevents the lift from rising unless the barrier is raised or closed or the supplementary system is engaged.

(6) *Platform surface.* The lift platform surface shall be free of any protrusions over ¼ inch high and shall be slip resistant. The lift platform shall have a minimum clear width of 28½ inches at the platform, a minimum clear width of 30 inches measured from 2 inches above the lift platform surface to 30 inches above the surface, and a minimum clear length of 48 inches measured from 2 inches above the surface of the platform to 30 inches above the surface. (See Fig. 1)

(7) *Platform gaps.* Any openings between the lift platform surface and the raised barriers shall not exceed ⅝ inch wide. When the lift is at vehicle floor height with the inner barrier (if applicable) down or retracted, gaps between the forward lift platform edge and vehicle floor shall not exceed ½ inch horizontally and ⅝ inch vertically. Platforms on semiautomatic lifts may have a hand hold not exceeding 1½ inches by 4½ inches located between the edge barriers.

(8) *Platform entrance ramp.* The entrance ramp, or loading-edge barrier used as a ramp, shall not exceed a slope

of 1:8 measured on level ground, for a maximum rise of 3 inches, and the transition from the station platform or roadway to ramp may be vertical without edge treatment up to ¼ inch. Thresholds between ¼ inch and ½ inch high shall be beveled with a slope no greater than 1:2.

(9) *Platform deflection.* The lift platform (not including the entrance ramp) shall not deflect more than 3 degrees (exclusive of vehicle roll) in any direction between its unloaded position and its position when loaded with 600 pounds applied through a 26 inch by 26 inch test pallet at the centroid of the lift platform.

(10) *Platform movement.* No part of the platform shall move at a rate exceeding 6 inches/second during lowering and lifting an occupant, and shall not exceed 12 inches/second during deploying or stowing. This requirement does not apply to the deployment or stowage cycles of lifts that are manually deployed or stowed. The maximum platform horizontal and vertical acceleration when occupied shall be 0.3g.

(11) *Boarding direction.* The lift shall permit both inboard and outboard facing of wheelchairs and mobility aids.

(12) *Use by standees.* Lifts shall accommodate persons using walkers, crutches, canes or braces or who otherwise have difficulty using steps. The lift may be marked to indicate a preferred standing position.

(13) *Handrails.* Platforms on lifts shall be equipped with handrails, on two sides, which move in tandem with the lift which shall be graspable and provide support to standees throughout the entire lift operation. Handrails shall have a usable component at least 8 inches long with the lowest portion a minimum 30 inches above the platform and the highest portion a maximum 38 inches above the platform. The handrails shall be capable of withstanding a force of 100 pounds concentrated at any point on the handrail without permanent deformation of the rail or its supporting structure. Handrails shall have a cross-sectional diameter between 1½ inches and 1¾ inches or shall provide an equivalent grasping surface, and have eased edges with corner radii of not less than ⅛ inch. Handrails shall be placed to provide a minimum 1½ inches

knuckle clearance from the nearest adjacent surface. Handrails shall not interfere with wheelchair or mobility aid maneuverability when entering or leaving the vehicle.

(c) *Vehicle ramp or bridge plate*—(1) *Design load.* Ramps or bridge plates 30 inches or longer shall support a load of 600 pounds, placed at the centroid of the ramp or bridge plate distributed over an area of 26 inches by 26 inches, with a safety factor of at least 3 based on the ultimate strength of the material. Ramps or bridge plates shorter than 30 inches shall support a load of 300 pounds.

(2) *Ramp surface.* The ramp or bridge plate surface shall be continuous and slip resistant, shall not have protrusions from the surface greater than  $\frac{1}{4}$  inch, shall have a clear width of 30 inches, and shall accommodate both four-wheel and three-wheel mobility aids.

(3) *Ramp threshold.* The transition from roadway or station platform and the transition from vehicle floor to the ramp or bridge plate may be vertical without edge treatment up to  $\frac{1}{4}$  inch. Changes in level between  $\frac{1}{4}$  inch and  $\frac{1}{2}$  inch shall be beveled with a slope no greater than 1:2.

(4) *Ramp barriers.* Each side of the ramp or bridge plate shall have barriers at least 2 inches high to prevent mobility aid wheels from slipping off.

(5) *Slope.* Ramps or bridge plates shall have the least slope practicable. If the height of the vehicle floor, under 50% passenger load, from which the ramp is deployed is 3 inches or less above the station platform a maximum slope of 1:4 is permitted; if the height of the vehicle floor, under 50% passenger load, from which the ramp is deployed is 6 inches or less, but more than 3 inches, above the station platform a maximum slope of 1:6 is permitted; if the height of the vehicle floor, under 50% passenger load, from which the ramp is deployed is 9 inches or less, but more than 6 inches, above the station platform a maximum slope of 1:8 is permitted; if the height of the vehicle floor, under 50% passenger load, from which the ramp is deployed is greater than 9 inches above the station platform a slope of 1:12 shall be achieved. Folding or telescoping ramps are per-

mitted provided they meet all structural requirements of this section.

(6) *Attachment*—(i) *Requirement.* When in use for boarding or alighting, the ramp or bridge plate shall be attached to the vehicle, or otherwise prevented from moving such that it is not subject to displacement when loading or unloading a heavy power mobility aid and that any gaps between vehicle and ramp or bridge plate, and station platform and ramp or bridge plate, shall not exceed  $\frac{5}{8}$  inch.

(ii) *Exception.* Ramps or bridge plates which are attached to, and deployed from, station platforms are permitted in lieu of vehicle devices provided they meet the displacement requirements of paragraph (c)(6)(i) of this section.

(7) *Stowage.* A compartment, securement system, or other appropriate method shall be provided to ensure that stowed ramps or bridge plates, including portable ramps or bridge plates stowed in the passenger area, do not impinge on a passenger's wheelchair or mobility aid or pose any hazard to passengers in the event of a sudden stop.

(8) *Handrails.* If provided, handrails shall allow persons with disabilities to grasp them from outside the vehicle while starting to board, and to continue to use them throughout the boarding process, and shall have the top between 30 inches and 38 inches above the ramp surface. The handrails shall be capable of withstanding a force of 100 pounds concentrated at any point on the handrail without permanent deformation of the rail or its supporting structure. The handrail shall have a cross-sectional diameter between  $1\frac{1}{4}$  inches and  $1\frac{1}{2}$  inches or shall provide an equivalent grasping surface, and have eased edges with corner radii of not less than  $\frac{1}{8}$  inch. Handrails shall not interfere with wheelchair or mobility aid maneuverability when entering or leaving the vehicle.

#### § 1192.85 Between-car barriers.

Where vehicles operate in a high-platform, level-boarding mode, devices or systems shall be provided to prevent, deter or warn individuals from inadvertently stepping off the platform

between cars. Appropriate devices include, but are not limited to, pantograph gates, chains, motion detectors or other suitable devices.

**§ 1192.87 Public information system.**

(a) Each vehicle shall be equipped with an interior public address system permitting transportation system personnel, or recorded or digitized human speech messages, to announce stations and provide other passenger information. Alternative systems or devices which provide equivalent access are also permitted.

(b) [Reserved]

**Subpart E—Commuter Rail Cars and Systems**

**§ 1192.91 General.**

(a) New, used and remanufactured commuter rail cars, to be considered accessible by regulations issued by the Department of Transportation in 49 CFR part 37, shall comply with this subpart.

(b) If portions of the car are modified in such a way that it affects or could affect accessibility, each such portion shall comply, to the extent practicable, with the applicable provisions of this subpart. This provision does not require that inaccessible cars be retrofitted with lifts, ramps or other boarding devices.

(c)(1) Commuter rail cars shall comply with §§ 1192.93(d) and 1192.109 for level boarding wherever structurally and operationally practicable.

(2) Where level boarding is not structurally or operationally practicable, commuter rail cars shall comply with § 1192.95.

(d) Existing vehicles retrofitted to comply with the "one-car-per-train rule" at 49 CFR 37.93 shall comply with §§ 1192.93(e), 1192.95(a) and 1192.107 and shall have, in new and key stations, at least one door on each side from which passengers board which complies with § 1192.93(d). Vehicles previously designed and manufactured in accordance with the program accessibility requirements of section 504 of the Rehabilitation Act of 1973, or implementing regulations issued by the Department of Transportation that were in effect before October 7, 1991, and which can be

entered and used from stations in which they are to be operated, may be used to satisfy the requirements of 49 CFR 37.93.

**§ 1192.93 Doorways.**

(a) *Clear width.* (1) At least one door on each side of the car from which passengers board opening onto station platforms and at least one adjacent doorway into the passenger coach compartment, if provided, shall have a minimum clear opening of 32 inches.

(2) If doorways connecting adjoining cars in a multi-car train are provided, and if such doorway is connected by an aisle with a minimum clear width of 30 inches to one or more spaces where wheelchair or mobility aid users can be accommodated, then such doorway shall have, to the maximum extent practicable in accordance with the regulations issued under the Federal Railroad Safety Act of 1970 (49 CFR parts 229 and 231), a clear opening of 30 inches.

(b) *Passageways.* A route at least 32 inches wide shall be provided from doors required to be accessible by paragraph (a)(1) of this section to seating locations complying with § 1192.95(d). In cars where such doorways require passage through a vestibule, such vestibule shall have a minimum width of 42 inches. (See Fig. 3)

(c) *Signals.* If doors to the platform close automatically or from a remote location, auditory and visual warning signals shall be provided to alert passengers of closing doors.

(d) *Coordination with boarding platform—(1) Requirements.* Cars operating in stations with high platforms, or mini-high platforms, shall be coordinated with the boarding platform design such that the horizontal gap between a car at rest and the platform shall be no greater than 3 inches and the height of the car floor shall be within plus or minus  $\frac{3}{8}$  inch of the platform height. Vertical alignment may be accomplished by car air suspension, platform lifts or other devices, or any combination.

(2) *Exception.* New vehicles operating in existing stations may have a floor height within plus or minus  $1\frac{1}{2}$  inches of the platform height. At key stations, the horizontal gap between at

## § 1192.95

least one accessible door of each such vehicle and the platform shall be no greater than 3 inches.

(3) *Exception.* Where platform setbacks do not allow the horizontal gap or vertical alignment specified in paragraph (d) (1) or (2) of this section, car, platform or portable lifts complying with §1192.95(b), or car or platform ramps or bridge plates, complying with §1192.95(c), shall be provided.

(4) *Exception.* Retrofitted vehicles shall be coordinated with the platform in new and key stations such that the horizontal gap shall be no greater than 4 inches and the height of the vehicle floor, under 50% passenger load, shall be within plus or minus 2 inches of the platform height.

(e) *Signage.* The International Symbol of Accessibility shall be displayed on the exterior of all doors complying with this section unless all cars are accessible and are not marked by the access symbol (See Fig. 6). Appropriate signage shall also indicate which accessible doors are adjacent to an accessible restroom, if applicable.

### § 1192.95 Mobility aid accessibility.

(a)(1) *General.* All new commuter rail cars, other than level entry cars, covered by this subpart shall provide a level-change mechanism or boarding device (e.g., lift, ramp or bridge plate) complying with either paragraph (b) or (c) of this section; sufficient clearances to permit a wheelchair or mobility aid user to reach a seating location; and at least two wheelchair or mobility aid seating locations complying with paragraph (d) of this section.

(2) *Exception.* If portable or platform lifts, ramps or bridge plates meeting the applicable requirements of this section are provided on station platforms or other stops, or mini-high platforms complying with §1192.93(d) are provided, at stations or stops required to be accessible by 49 CFR part 37, the car is not required to be equipped with a car-borne device. Where each new car is compatible with a single platform-mounted access system or device, additional systems or devices are not required for each car provided that the single device could be used to provide access to each new car if passengers using wheelchairs or mobility aids

## 36 CFR Ch. XI (7–1–03 Edition)

could not be accommodated on a single car.

(b) *Car Lift—(1) Design load.* The design load of the lift shall be at least 600 pounds. Working parts, such as cables, pulleys, and shafts, which can be expected to wear, and upon which the lift depends for support of the load, shall have a safety factor of at least six, based on the ultimate strength of the material. Nonworking parts, such as platform, frame, and attachment hardware which would not be expected to wear, shall have a safety factor of at least three, based on the ultimate strength of the material.

(2) *Controls—(i) Requirements.* The controls shall be interlocked with the car brakes, propulsion system, or door, or shall provide other appropriate mechanisms or systems, to ensure that the car cannot be moved when the lift is not stowed and so the lift cannot be deployed unless the interlocks or systems are engaged. The lift shall deploy to all platform levels normally encountered in the operating environment. Where provided, each control for deploying, lowering, raising, and stowing the lift and lowering the roll-off barrier shall be of a momentary contact type requiring continuous manual pressure by the operator and shall not allow improper lift sequencing when the lift platform is occupied. The controls shall allow reversal of the lift operation sequence, such as raising or lowering a platform that is part way down, without allowing an occupied platform to fold or retract into the stowed position.

(ii) *Exception.* Where physical or safety constraints prevent the deployment at some stops of a lift having its long dimension perpendicular to the car axis, the transportation entity may specify a lift which is designed to deploy with its long dimension parallel to the car axis and which pivots into or out of the car while occupied (i.e., “rotary lift”). The requirements of paragraph (b)(2)(i) of this section prohibiting the lift from being stowed while occupied shall not apply to a lift design of this type if the stowed position is within the passenger compartment and the lift is intended to be stowed while occupied.

(iii) *Exception.* The brake or propulsion system interlock requirement does not apply to a platform mounted or portable lift provided that a mechanical, electrical or other system operates to ensure that cars do not move when the lift is in use.

(3) *Emergency operation.* The lift shall incorporate an emergency method of deploying, lowering to ground or platform level with a lift occupant, and raising and stowing the empty lift if the power to the lift fails. No emergency method, manual or otherwise, shall be capable of being operated in a manner that could be hazardous to the lift occupant or to the operator when operated according to manufacturer's instructions, and shall not permit the platform to be stowed or folded when occupied, unless the lift is a rotary lift intended to be stowed while occupied.

(4) *Power or equipment failure.* Platforms stowed in a vertical position, and deployed platforms when occupied, shall have provisions to prevent their deploying, falling, or folding any faster than 12 inches/second or their dropping of an occupant in the event of a single failure of any load carrying component.

(5) *Platform barriers.* The lift platform shall be equipped with barriers to prevent any of the wheels of a wheelchair or mobility aid from rolling off the lift during its operation. A movable barrier or inherent design feature shall prevent a wheelchair or mobility aid from rolling off the edge closest to the car until the lift is in its fully raised position. Each side of the lift platform which, in its raised position, extends beyond the car shall have a barrier a minimum 1½ inches high. Such barriers shall not interfere with maneuvering into or out of the car. The loading-edge barrier (outer barrier) which functions as a loading ramp when the lift is at ground or station platform level, shall be sufficient when raised or closed, or a supplementary system shall be provided, to prevent a power wheelchair or mobility aid from riding over or defeating it. The outer barrier of the lift shall automatically rise or close, or a supplementary system shall automatically engage, and remain raised, closed, or engaged at all times that the lift platform is more than 3

inches above the station platform and the lift is occupied. Alternatively, a barrier or system may be raised, lowered, opened, closed, engaged or disengaged by the lift operator provided an interlock or inherent design feature prevents the lift from rising unless the barrier is raised or closed or the supplementary system is engaged.

(6) *Platform surface.* The lift platform surface shall be free of any protrusions over ¼ inch high and shall be slip resistant. The lift platform shall have a minimum clear width of 28½ inches at the platform, a minimum clear width of 30 inches measured from 2 inches above the lift platform surface to 30 inches above the surface, and a minimum clear length of 48 inches measured from 2 inches above the surface of the platform to 30 inches above the surface. (See Fig. 1)

(7) *Platform gaps.* Any openings between the lift platform surface and the raised barriers shall not exceed ⅝ inch wide. When the lift is at car floor height with the inner barrier down (if applicable) or retracted, gaps between the forward lift platform edge and car floor shall not exceed ½ inch horizontally and ⅝ inch vertically. Platforms on semi-automatic lifts may have a hand hold not exceeding 1½ inches by 4½ inches located between the edge barriers.

(8) *Platform entrance ramp.* The entrance ramp, or loading-edge barrier used as a ramp, shall not exceed a slope of 1:8, when measured on level ground, for a maximum rise of 3 inches, and the transition from station platform to ramp may be vertical without edge treatment up to ¼ inch. Thresholds between ¼ inch and ½ inch high shall be beveled with a slope no greater than 1:2.

(9) *Platform deflection.* The lift platform (not including the entrance ramp) shall not deflect more than 3 degrees (exclusive of vehicle roll) in any direction between its unloaded position and its position when loaded with 600 pounds applied through a 26 inch by 26 inch test pallet at the centroid of the lift platform.

(10) *Platform movement.* No part of the platform shall move at a rate exceeding 6 inches/second during lowering and

lifting an occupant, and shall not exceed 12 inches/second during deploying or stowing. This requirement does not apply to the deployment or stowage cycles of lifts that are manually deployed or stowed. The maximum platform horizontal and vertical acceleration when occupied shall be 0.3g.

(11) *Boarding direction.* The lift shall permit both inboard and outboard facing of wheelchairs and mobility aids.

(12) *Use by standees.* Lifts shall accommodate persons using walkers, crutches, canes or braces or who otherwise have difficulty using steps. The lift may be marked to indicate a preferred standing position.

(13) *Handrails.* Platforms on lifts shall be equipped with handrails, on two sides, which move in tandem with the lift which shall be graspable and provide support to standees throughout the entire lift operation. Handrails shall have a usable component at least 8 inches long with the lowest portion a minimum 30 inches above the platform and the highest portion a maximum 38 inches above the platform. The handrails shall be capable of withstanding a force of 100 pounds concentrated at any point on the handrail without permanent deformation of the rail or its supporting structure. The handrail shall have a cross-sectional diameter between 1¼ inches and 1½ inches or shall provide an equivalent grasping surface, and have eased edges with corner radii of not less than ⅛ inch. Handrails shall be placed to provide a minimum 1½ inches knuckle clearance from the nearest adjacent surface. Handrails shall not interfere with wheelchair or mobility aid maneuverability when entering or leaving the car.

(c) *Car ramp or bridge plate—(1) Design load.* Ramps or bridge plates 30 inches or longer shall support a load of 600 pounds, placed at the centroid of the ramp or bridge plate distributed over an area of 26 inches by 26 inches, with a safety factor of at least 3 based on the ultimate strength of the material. Ramps or bridge plates shorter than 30 inches shall support a load of 300 pounds.

(2) *Ramp surface.* The ramp or bridge plate surface shall be continuous and slip resistant, shall not have protrusions from the surface greater than ¼

inch high, shall have a clear width of 30 inches and shall accommodate both four-wheel and three-wheel mobility aids.

(3) *Ramp threshold.* The transition from station platform to the ramp or bridge plate and the transition from car floor to the ramp or bridge plate may be vertical without edge treatment up to ¼ inch. Changes in level between ¼ inch and ½ inch shall be beveled with a slope no greater than 1:2.

(4) *Ramp barriers.* Each side of the ramp or bridge plate shall have barriers at least 2 inches high to prevent mobility aid wheels from slipping off.

(5) *Slope.* Ramps or bridge plates shall have the least slope practicable. If the height of the vehicle floor, under 50% passenger load, from which the ramp is deployed is 3 inches or less above the station platform a maximum slope of 1:4 is permitted; if the height of the vehicle floor, under 50% passenger load, from which the ramp is deployed is 6 inches or less, but more than 3 inches, above the station platform a maximum slope of 1:6 is permitted; if the height of the vehicle floor, under 50% passenger load, from which the ramp is deployed is 9 inches or less, but more than 6 inches, above the station platform a maximum slope of 1:8 is permitted; if the height of the vehicle floor, under 50% passenger load, from which the ramp is deployed is greater than 9 inches above the station platform a slope of 1:12 shall be achieved. Folding or telescoping ramps are permitted provided they meet all structural requirements of this section.

(6) *Attachment—(i) Requirement.* When in use for boarding or alighting, the ramp or bridge plate shall be attached to the vehicle, or otherwise prevented from moving such that it is not subject to displacement when loading or unloading a heavy power mobility aid and that any gaps between vehicle and ramp or bridge plates, and station platform and ramp or bridge plate, shall not exceed ⅝ inch.

(ii) *Exception.* Ramps or bridge plates which are attached to, and deployed from, station platforms are permitted in lieu of car devices provided they meet the displacement requirements of paragraph (c)(6)(i) of this section.



(7) *Stowage.* A compartment, securement system, or other appropriate method shall be provided to ensure that stowed ramps or bridge plates, including portable ramps or bridge plates stowed in the passenger area, do not impinge on a passenger's wheelchair or mobility aid or pose any hazard to passengers in the event of a sudden stop.

(8) *Handrails.* If provided, handrails shall allow persons with disabilities to grasp them from outside the car while starting to board, and to continue to use them throughout the boarding process, and shall have the top between 30 inches and 38 inches above the ramp surface. The handrails shall be capable of withstanding a force of 100 pounds concentrated at any point on the handrail without permanent deformation of the rail or its supporting structure. The handrail shall have a cross-sectional diameter between 1¼ inches and 1½ inches or shall provide an equivalent grasping surface, and have eased edges with corner radii of not less than ⅛ inch. Handrails shall not interfere with wheelchair or mobility aid maneuverability when entering or leaving the car.

(d) *Mobility aid seating location.* Spaces for persons who wish to remain in their wheelchairs or mobility aids shall have a minimum clear floor space 48 inches by 30 inches. Such spaces shall adjoin, and may overlap, an accessible path. Not more than 6 inches of the required clear floor space may be accommodated for footrests under another seat provided there is a minimum of 9 inches from the floor to the lowest part of the seat overhanging the space. Seating spaces may have fold-down or removable seats to accommodate other passengers when a wheelchair or mobility aid user is not occupying the area, provided the seats, when folded up, do not obstruct the clear floor space required. (See Fig. 2)

**§ 1192.97 Interior circulation, handrails and stanchions.**

(a) Where provided, handrails or stanchions within the passenger compartment shall be placed to permit sufficient turning and maneuvering space for wheelchairs and other mobility aids to reach a seating location, complying with § 1192.95(d), from an accessible en-

trance. The diameter or width of the gripping surface of interior handrails and stanchions shall be 1¼ inches to 1½ inches or shall provide an equivalent gripping surface. Handrails shall be placed to provide a minimum 1½ inches knuckle clearance from the nearest adjacent surface.

(b) Where provided, handrails or stanchions shall be sufficient to permit safe boarding, on-board circulation, seating and standing assistance, and alighting by persons with disabilities.

(c) At entrances equipped with steps, handrails or stanchions shall be provided in the entrance to the car in a configuration which allows passengers to grasp such assists from outside the car while starting to board, and to continue using such assists throughout the boarding process, to the extent permitted by 49 CFR part 231.

**§ 1192.99 Floors, steps and thresholds.**

(a) Floor surfaces on aisles, step treads, places for standees, and areas where wheelchair and mobility aid users are to be accommodated shall be slip-resistant.

(b) All thresholds and step edges shall have a band of color(s) running the full width of the step or threshold which contrasts from the step tread and riser or adjacent floor, either light-on-dark or dark-on-light.

**§ 1192.101 Lighting.**

(a) Any stepwell or doorway with a lift, ramp or bridge plate shall have, when the door is open, at least 2 foot-candles of illumination measured on the step tread, ramp, bridge plate, or lift platform.

(b) The doorways of cars not operating at lighted station platforms shall have outside lights which, when the door is open, provide at least 1 foot-candle of illumination on the station platform surface for a distance of 3 feet perpendicular to all points on the bottom step tread edge. Such lights shall be shielded to protect the eyes of entering and exiting passengers.

**§ 1192.103 Public information system.**

(a) Each car shall be equipped with an interior public address system permitting transportation system personnel, or recorded or digitized human

**§ 1192.105**

speech messages, to announce stations and provide other passenger information. Alternative systems or devices which provide equivalent access are also permitted.

(b) [Reserved]

**§ 1192.105 Priority seating signs.**

(a) Each car shall contain sign(s) which indicate that certain seats are priority seats for persons with disabilities and that other passengers should make such seats available to those who wish to use them.

(b) Characters on signs required by paragraph (a) shall have a width-to-height ratio between 3:5 and 1:1 and a stroke width-to-height ratio between 1:5 and 1:10, with a minimum character height (using an upper case "X") of  $\frac{5}{8}$  inch, with "wide" spacing (generally, the space between letters shall be  $\frac{1}{16}$  the height of upper case letters), and shall contrast with the background either light-on-dark or dark-on-light.

**§ 1192.107 Restrooms.**

(a) If a restroom is provided for the general public, it shall be designed so as to allow a person using a wheelchair or mobility aid to enter and use such restroom as specified in paragraphs (a) (1) through (5) of this section.

(1) The minimum clear floor area shall be 35 inches by 60 inches. Permanently installed fixtures may overlap this area a maximum of 6 inches, if the lowest portion of the fixture is a minimum of 9 inches above the floor, and may overlap a maximum of 19 inches, if the lowest portion of the fixture is a minimum of 29 inches above the floor, provided such fixtures do not interfere with access to the water closet. Fold-down or retractable seats or shelves may overlap the clear floor space at a lower height provided they can be easily folded up or moved out of the way.

(2) The height of the water closet shall be 17 inches to 19 inches measured to the top of the toilet seat. Seats shall not be sprung to return to a lifted position.

(3) A grab bar at least 24 inches long shall be mounted behind the water closet, and a horizontal grab bar at least 40 inches long shall be mounted on at least one side wall, with one end not more than 12 inches from the back

**36 CFR Ch. XI (7-1-03 Edition)**

wall, at a height between 33 inches and 36 inches above the floor.

(4) Faucets and flush controls shall be operable with one hand and shall not require tight grasping, pinching, or twisting of the wrist. The force required to activate controls shall be no greater than 5 lbf (22.2 N). Controls for flush valves shall be mounted no more than 44 inches above the floor.

(5) Doorways on the end of the enclosure, opposite the water closet, shall have a minimum clear opening width of 32 inches. Doorways on the side wall shall have a minimum clear opening width of 39 inches. Door latches and hardware shall be operable with one hand and shall not require tight grasping, pinching, or twisting of the wrist.

(b) Restrooms required to be accessible shall be in close proximity to at least one seating location for persons using mobility aids and shall be connected to such a space by an unobstructed path having a minimum width of 32 inches.

**§ 1192.109 Between-car barriers.**

Where vehicles operate in a high-platform, level-boarding mode, and where between-car bellows are not provided, devices or systems shall be provided to prevent, deter or warn individuals from inadvertently stepping off the platform between cars. Appropriate devices include, but are not limited to, pantograph gates, chains, motion detectors or other suitable devices.

**Subpart F—Intercity Rail Cars and Systems**

**§ 1192.111 General.**

(a) New, used and remanufactured intercity rail cars, to be considered accessible by regulations issued by the Department of Transportation in 49 CFR part 37, shall comply with this subpart to the extent required for each type of car as specified below.

(1) Single-level rail passenger coaches and food service cars (other than single-level dining cars) shall comply with §§ 1192.113 through 1192.123. Compliance with § 1192.125 shall be required only to the extent necessary to meet the requirements of paragraph (d) of this section.

(2) Single-level dining and lounge cars shall have at least one connecting doorway complying with § 1192.113(a)(2), connected to a car accessible to persons using wheelchairs or mobility aids, and at least one space complying with § 1192.125(d) (2) and (3), to provide table service to a person who wishes to remain in his or her wheelchair, and space to fold and store a wheelchair for a person who wishes to transfer to an existing seat.

(3) Bi-level dining cars shall comply with §§ 1192.113(a)(2), 1192.115(b), 1192.117(a), and 1192.121.

(4) Bi-level lounge cars shall have doors on the lower level, on each side of the car from which passengers board, complying with § 1192.113, a restroom complying with § 1192.123, and at least one space complying with § 1192.125(d) (2) and (3) to provide table service to a person who wishes to remain in his or her wheelchair and space to fold and store a wheelchair for a person who wishes to transfer to an existing seat.

(5) Restrooms complying with § 1192.123 shall be provided in single-level rail passenger coaches and food service cars adjacent to the accessible seating locations required by paragraph (d) of this section. Accessible restrooms are required in dining and lounge cars only if restrooms are provided for other passengers.

(6) Sleeper cars shall comply with §§ 1192.113 (b) through (d), 1192.115 through 1192.121, and 1192.125, and have at least one compartment which can be entered and used by a person using a wheelchair or mobility aid and complying with § 1192.127.

(b)(1) If physically and operationally practicable, intercity rail cars shall comply with § 1192.113(d) for level boarding.

(2) Where level boarding is not structurally or operationally practicable, intercity rail cars shall comply with § 1192.125.

(c) If portions of the car are modified in a way that affects or could affect accessibility, each such portion shall comply, to the extent practicable, with the applicable provisions of this subpart. This provision does not require that inaccessible cars be retrofitted with lifts, ramps or other boarding devices.

(d) Passenger coaches or food service cars shall have the number of spaces complying with § 1192.125(d)(2) and the number of spaces complying with § 1192.125(d)(3), as required by 49 CFR 37.91.

(e) Existing cars retrofitted to meet the seating requirements of 49 CFR 37.91 shall comply with §§ 1192.113(e), 1192.123, 1192.125(d) and shall have at least one door on each side from which passengers board complying with § 1192.113(d). Existing cars designed and manufactured to be accessible in accordance with Department of Transportation regulations implementing section 504 of the Rehabilitation Act of 1973 that were in effect before October 7, 1991, shall comply with § 1192.125(a).

#### § 1192.113 Doorways.

(a) *Clear width.* (1) At least one doorway, on each side of the car from which passengers board, of each car required to be accessible by § 1192.111(a) and where the spaces required by § 1192.111(d) are located, and at least one adjacent doorway into coach passenger compartments shall have a minimum clear opening width of 32 inches.

(2) Doorways at ends of cars connecting two adjacent cars, to the maximum extent practicable in accordance with regulations issued under the Federal Railroad Safety Act of 1970 (49 CFR parts 229 and 231), shall have a clear opening width of 32 inches to permit wheelchair and mobility aid users to enter into a single-level dining car, if available.

(b) *Passaway.* Doorways required to be accessible by paragraph (a) of this section shall permit access by persons using mobility aids and shall have an unobstructed passageway at least 32 inches wide leading to an accessible sleeping compartment complying with § 1192.127 or seating locations complying with § 1192.125(d). In cars where such doorways require passage through a vestibule, such vestibule shall have a minimum width of 42 inches. (see Fig. 4)

(c) *Signals.* If doors to the platform close automatically or from a remote location, auditory and visual warning signals shall be provided to alert passengers of closing doors.

## § 1192.115

(d) *Coordination with boarding platforms*—(1) *Requirements.* Cars which provide level-boarding in stations with high platforms shall be coordinated with the boarding platform or mini-high platform design such that the horizontal gap between a car at rest and the platform shall be no greater than 3 inches and the height of the car floor shall be within plus or minus  $\frac{5}{8}$  inch of the platform height. Vertical alignment may be accomplished by car air suspension, platform lifts or other devices, or any combination.

(2) *Exception.* New cars operating in existing stations may have a floor height within plus or minus  $1\frac{1}{2}$  inches of the platform height.

(3) *Exception.* Where platform setbacks do not allow the horizontal gap or vertical alignment specified in paragraph (d) (1) or (2) of this section, platform or portable lifts complying with § 1192.125(b), or car or platform bridge plates, complying with § 1192.125(c), may be provided.

(4) *Exception.* Retrofitted vehicles shall be coordinated with the platform in existing stations such that the horizontal gap shall be no greater than 4 inches and the height of the vehicle floor, under 50% passenger load, shall be within plus or minus 2 inches of the platform height.

(e) *Signage.* The International Symbol of Accessibility shall be displayed on the exterior of all doors complying with this section unless all cars and doors are accessible and are not marked by the access symbol (see Fig. 6). Appropriate signage shall also indicate which accessible doors are adjacent to an accessible restroom, if applicable.

## § 1192.115 Interior circulation, handrails and stanchions.

(a) Where provided, handrails or stanchions within the passenger compartment shall be placed to permit sufficient turning and maneuvering space for wheelchairs and other mobility aids to reach a seating location, complying with § 1192.125(d), from an accessible entrance. The diameter or width of the gripping surface of interior handrails and stanchions shall be  $1\frac{1}{4}$  inches to  $1\frac{1}{2}$  inches or shall provide an equivalent gripping surface. Handrails shall

## 36 CFR Ch. XI (7–1–03 Edition)

be placed to provide a minimum  $1\frac{1}{2}$  inches knuckle clearance from the nearest adjacent surface.

(b) Where provided, handrails and stanchions shall be sufficient to permit safe boarding, on-board circulation, seating and standing assistance, and alighting by persons with disabilities.

(c) At entrances equipped with steps, handrails or stanchions shall be provided in the entrance to the car in a configuration which allows passengers to grasp such assists from outside the car while starting to board, and to continue using such assists throughout the boarding process, to the extent permitted by 49 CFR part 231.

## § 1192.117 Floors, steps and thresholds.

(a) Floor surfaces on aisles, step treads and areas where wheelchair and mobility aid users are to be accommodated shall be slip-resistant.

(b) All step edges and thresholds shall have a band of color(s) running the full width of the step or threshold which contrasts from the step tread and riser or adjacent floor, either light-on-dark or dark-on-light.

## § 1192.119 Lighting.

(a) Any stepwell, or doorway with a lift, ramp or bridge plate, shall have, when the door is open, at least 2 foot-candles of illumination measured on the step tread, ramp, bridge plate or lift platform.

(b) The doorways of cars not operating at lighted station platforms shall have outside lights which, when the door is open, provide at least 1 foot-candle of illumination on the station platform surface for a distance of 3 feet perpendicular to all points on the bottom step tread edge. Such lights shall be shielded to protect the eyes of entering and exiting passengers.

## § 1192.121 Public information system.

(a) Each car shall be equipped with a public address system permitting transportation system personnel, or recorded or digitized human speech messages, to announce stations and provide other passenger information. Alternative systems or devices which provide equivalent access are also permitted.

(b) [Reserved]

**§ 1192.123 Restrooms.**

(a) If a restroom is provided for the general public, and an accessible restroom is required by § 1192.111 (a) and (e), it shall be designed so as to allow a person using a wheelchair or mobility aid to enter and use such restroom as specified in paragraphs (a) (1) through (5) of this section.

(1) The minimum clear floor area shall be 35 inches by 60 inches. Permanently installed fixtures may overlap this area a maximum of 6 inches, if the lowest portion of the fixture is a minimum of 9 inches above the floor, and may overlap a maximum of 19 inches, if the lowest portion of the fixture is a minimum of 29 inches above the floor. Fixtures shall not interfere with access to and use of the water closet. Fold-down or retractable seats or shelves may overlap the clear floor space at a lower height provided they can be easily folded up or moved out of the way.

(2) The height of the water closet shall be 17 inches to 19 inches measured to the top of the toilet seat. Seats shall not be sprung to return to a lifted position.

(3) A grab bar at least 24 inches long shall be mounted behind the water closet, and a horizontal grab bar at least 40 inches long shall be mounted on at least one side wall, with one end not more than 12 inches from the back wall, at a height between 33 inches and 36 inches above the floor.

(4) Faucets and flush controls shall be operable with one hand and shall not require tight grasping, pinching, or twisting of the wrist. The force required to activate controls shall be no greater than 5 lbf (22.2 N). Controls for flush valves shall be mounted no more than 44 inches above the floor.

(5) Doorways on the end of the enclosure, opposite the water closet, shall have a minimum clear opening width of 32 inches. Doorways on the side wall shall have a minimum clear opening width of 39 inches. Door latches and hardware shall be operable with one hand and shall not require tight grasping, pinching, or twisting of the wrist.

(b) Restrooms required to be accessible shall be in close proximity to at least one seating location for persons using mobility aids complying with § 1192.125(d) and shall be connected to

such a space by an unobstructed path having a minimum width of 32 inches.

**§ 1192.125 Mobility aid accessibility.**

(a)(1) *General.* All intercity rail cars, other than level entry cars, required to be accessible by § 1192.111 (a) and (e) of this subpart shall provide a level-change mechanism or boarding device (e.g., lift, ramp or bridge plate) complying with either paragraph (b) or (c) of this section and sufficient clearances to permit a wheelchair or other mobility aid user to reach a seating location complying with paragraph (d) of this section.

(2) *Exception.* If portable or platform lifts, ramps or bridge plates meeting the applicable requirements of this section are provided on station platforms or other stops, or mini-high platforms complying with § 1192.113(d) are provided, at stations or stops required to be accessible by 49 CFR part 37, the car is not required to be equipped with a car-borne device.

(b) *Car Lift*—(1) *Design load.* The design load of the lift shall be at least 600 pounds. Working parts, such as cables, pulleys, and shafts, which can be expected to wear, and upon which the lift depends for support of the load, shall have a safety factor of at least six, based on the ultimate strength of the material. Nonworking parts, such as platform, frame, and attachment hardware which would not be expected to wear, shall have a safety factor of at least three, based on the ultimate strength of the material.

(2) *Controls*—(i) *Requirements.* The controls shall be interlocked with the car brakes, propulsion system, or door, or shall provide other appropriate mechanisms or systems, to ensure that the car cannot be moved when the lift is not stowed and so the lift cannot be deployed unless the interlocks or systems are engaged. The lift shall deploy to all platform levels normally encountered in the operating environment. Where provided, each control for deploying, lowering, raising, and stowing the lift and lowering the roll-off barrier shall be of a momentary contact type requiring continuous manual pressure by the operator and shall not allow improper lift sequencing when

the lift platform is occupied. The controls shall allow reversal of the lift operation sequence, such as raising or lowering a platform that is part way down, without allowing an occupied platform to fold or retract into the stowed position.

(ii) *Exception.* Where physical or safety constraints prevent the deployment at some stops of a lift having its long dimension perpendicular to the car axis, the transportation entity may specify a lift which is designed to deploy with its long dimension parallel to the car axis and which pivots into or out of the car while occupied (i.e., "rotary lift"). The requirements of paragraph (b)(2)(i) of this section prohibiting the lift from being stowed while occupied shall not apply to a lift design of this type if the stowed position is within the passenger compartment and the lift is intended to be stowed while occupied.

(iii) *Exception.* The brake or propulsion system interlocks requirement does not apply to platform mounted or portable lifts provided that a mechanical, electrical or other system operates to ensure that cars do not move when the lift is in use.

(3) *Emergency operation.* The lift shall incorporate an emergency method of deploying, lowering to ground or station platform level with a lift occupant, and raising and stowing the empty lift if the power to the lift fails. No emergency method, manual or otherwise, shall be capable of being operated in a manner that could be hazardous to the lift occupant or to the operator when operated according to manufacturer's instructions, and shall not permit the platform to be stowed or folded when occupied, unless the lift is a rotary lift and is intended to be stowed while occupied.

(4) *Power or equipment failure.* Platforms stowed in a vertical position, and deployed platforms when occupied, shall have provisions to prevent their deploying, failing, or folding any faster than 12 inches/second or their dropping of an occupant in the event of a single failure of any load carrying component.

(5) *Platform barriers.* The lift platform shall be equipped with barriers to prevent any of the wheels of a wheelchair

or mobility aid from rolling off the lift during its operation. A movable barrier or inherent design feature shall prevent a wheelchair or mobility aid from rolling off the edge closest to the car until the lift is in its fully raised position. Each side of the lift platform which, in its raised position, extends beyond the car shall have a barrier a minimum 1½ inches high. Such barriers shall not interfere with maneuvering into or out of the car. The loading-edge barrier (outer barrier) which functions as a loading ramp when the lift is at ground or station platform level, shall be sufficient when raised or closed, or a supplementary system shall be provided, to prevent a power wheelchair or mobility aid from riding over or defeating it. The outer barrier of the lift shall automatically rise or close, or a supplementary system shall automatically engage, and remain raised, closed, or engaged at all times that the lift platform is more than 3 inches above the station platform and the lift is occupied. Alternatively, a barrier or system may be raised, lowered, opened, closed, engaged or disengaged by the lift operator provided an interlock or inherent design feature prevents the lift from rising unless the barrier is raised or closed or the supplementary system is engaged.

(6) *Platform surface.* The lift platform surface shall be free of any protrusions over ¼ inch high and shall be slip resistant. The lift platform shall have a minimum clear width of 28½ inches at the platform, a minimum clear width of 30 inches measured from 2 inches above the lift platform surface to 30 inches above the surface, and a minimum clear length of 48 inches measured from 2 inches above the surface of the platform to 30 inches above the surface. (See Fig. 1.)

(7) *Platform gaps.* Any openings between the lift platform surface and the raised barriers shall not exceed ⅝ inch wide. When the lift is at car floor height with the inner barrier (if applicable) down or retracted, gaps between the forward lift platform edge and car floor shall not exceed ½ inch horizontally and ⅝ inch vertically. Platforms on semi-automatic lifts may have a hand hold not exceeding 1½

inches by 4½ inches located between the edge barriers.

(8) *Platform entrance ramp.* The entrance ramp, or loading-edge barrier used as a ramp, shall not exceed a slope of 1:8, when measured on level ground, for a maximum rise of 3 inches, and the transition from station platform to ramp may be vertical without edge treatment up to ¼ inch. Thresholds between ¼ inch and ½ inch high shall be beveled with a slope no greater than 1:2.

(9) *Platform deflection.* The lift platform (not including the entrance ramp) shall not deflect more than 3 degrees (exclusive of car roll) in any direction between its unloaded position and its position when loaded with 600 pounds applied through a 26 inch by 26 inch test pallet at the centroid of the lift platform.

(10) *Platform movement.* No part of the platform shall move at a rate exceeding 6 inches/second during lowering and lifting an occupant, and shall not exceed 12 inches/second during deploying or stowing. This requirement does not apply to the deployment or stowage cycles of lifts that are manually deployed or stowed. The maximum platform horizontal and vertical acceleration when occupied shall be 0.3g.

(11) *Boarding direction.* The lift shall permit both inboard and outboard facing of wheelchairs and mobility aids.

(12) *Use by standees.* Lifts shall accommodate persons using walkers, crutches, canes or braces or who otherwise have difficulty using steps. The lift may be marked to indicate a preferred standing position.

(13) *Handrails.* Platforms on lifts shall be equipped with handrails, on two sides, which move in tandem with the lift, and which shall be graspable and provide support to standees throughout the entire lift operation. Handrails shall have a usable component at least 8 inches long with the lowest portion a minimum 30 inches above the platform and the highest portion a maximum 38 inches above the platform. The handrails shall be capable of withstanding a force of 100 pounds concentrated at any point on the handrail without permanent deformation of the rail or its supporting structure. The handrail shall have a

cross-sectional diameter between 1¼ inches and 1½ inches or shall provide an equivalent grasping surface, and have eased edges with corner radii of not less than ⅛ inch. Handrails shall be placed to provide a minimum 1½ inches knuckle clearance from the nearest adjacent surface. Handrails shall not interfere with wheelchair or mobility aid maneuverability when entering or leaving the car.

(c) *Car ramp or bridge plate—(1) Design load.* Ramps or bridge plates 30 inches or longer shall support a load of 600 pounds, placed at the centroid of the ramp or bridge plate distributed over an area of 26 inches by 26 inches, with a safety factor of at least 3 based on the ultimate strength of the material. Ramps or bridge plates shorter than 30 inches shall support a load of 300 pounds.

(2) *Ramp surface.* The ramp or bridge plate surface shall be continuous and slip resistant, shall not have protrusions from the surface greater than ¼ inch high, shall have a clear width of 30 inches and shall accommodate both four-wheel and three-wheel mobility aids.

(3) *Ramp threshold.* The transition from station platform to the ramp or bridge plate and the transition from car floor to the ramp or bridge plate may be vertical without edge treatment up to ¼ inch. Changes in level between ¼ inch and ½ inch shall be beveled with a slope no greater than 1:2.

(4) *Ramp barriers.* Each side of the ramp or bridge plate shall have barriers at least 2 inches high to prevent mobility aid wheels from slipping off.

(5) *Slope.* Ramps or bridge plates shall have the least slope practicable. If the height of the vehicle floor, under 50% passenger load, from which the ramp is deployed is 3 inches or less above the station platform a maximum slope of 1:4 is permitted; if the height of the vehicle floor, under 50% passenger load, from which the ramp is deployed is 6 inches or less, but more than 3 inches, above the station platform a maximum slope of 1:6 is permitted; if the height of the vehicle floor, under 50% passenger load, from which the ramp is deployed is 9 inches or less, but more

§ 1192.127

36 CFR Ch. XI (7-1-03 Edition)

than 6 inches, above the station platform a maximum slope of 1:8 is permitted; if the height of the vehicle floor, under 50% passenger load, from which the ramp is deployed is greater than 9 inches above the station platform a slope of 1:12 shall be achieved. Folding or telescoping ramps are permitted provided they meet all structural requirements of this section.

(6) *Attachment*—(i) *Requirement*. When in use for boarding or alighting, the ramp or bridge plate shall be attached to the vehicle, or otherwise prevented from moving such that it is not subject to displacement when loading or unloading a heavy power mobility aid and that any gaps between vehicle and ramp or bridge plate, and station platform and ramp or bridge plate, shall not exceed  $\frac{5}{8}$  inch.

(ii) *Exception*. Ramps or bridge plates which are attached to, and deployed from, station platforms are permitted in lieu of car devices provided they meet the displacement requirements of paragraph (c)(6)(i) of this section.

(7) *Stowage*. A compartment, securement system, or other appropriate method shall be provided to ensure that stowed ramps or bridge plates, including portable ramps or bridge plates stowed in the passenger area, do not impinge on a passenger's wheelchair or mobility aid or pose any hazard to passengers in the event of a sudden stop.

(8) *Handrails*. If provided, handrails shall allow persons with disabilities to grasp them from outside the car while starting to board, and to continue to use them throughout the boarding process, and shall have the top between 30 inches and 38 inches above the ramp surface. The handrails shall be capable of withstanding a force of 100 pounds concentrated at any point on the handrail without permanent deformation of the rail or its supporting structure. The handrail shall have a cross-sectional diameter between  $\frac{1}{4}$  inches and  $\frac{1}{2}$  inches or shall provide an equivalent grasping surface, and have eased edges with corner radii of not less than  $\frac{1}{8}$  inch. Handrails shall not interfere with wheelchair or mobility aid maneuverability when entering or leaving the car.

(d) *Seating*—(1) *Requirements*. All intercity rail cars required to be acces-

sible by § 1192.111 (a) and (e) of this subpart shall provide at least one, but not more than two, mobility aid seating location(s) complying with paragraph (d)(2) of this section; and at least one, but not more than two, seating location(s) complying with paragraph (d)(3) of this section which adjoin or overlap an accessible route with a minimum clear width of 32 inches.

(2) *Wheelchair or mobility aid spaces*. Spaces for persons who wish to remain in their wheelchairs or mobility aids shall have a minimum clear floor area 48 inches by 30 inches. Such space may have fold-down or removable seats for use when not occupied by a wheelchair or mobility aid user. (See Fig. 2)

(3) *Other spaces*. Spaces for individuals who wish to transfer shall include a regular coach seat or dining car booth or table seat and space to fold and store the passenger's wheelchair.

§ 1192.127 **Sleeping compartments.**

(a) Sleeping compartments required to be accessible shall be designed so as to allow a person using a wheelchair or mobility aid to enter, maneuver within and approach and use each element within such compartment. (See Fig. 5.)

(b) Each accessible compartment shall contain a restroom complying with § 1192.123(a) which can be entered directly from such compartment.

(c) Controls and operating mechanisms (e.g., heating and air conditioning controls, lighting controls, call buttons, electrical outlets, etc.) shall be mounted no more than 48 inches, and no less than 15 inches, above the floor and shall have a clear floor area directly in front a minimum of 30 inches by 48 inches. Controls and operating mechanisms shall be operable with one hand and shall not require tight grasping, pinching, or twisting of the wrist.

**Subpart G—Over-the-Road Buses and Systems**

§ 1192.151 **General.**

(a) New, used and remanufactured over-the-road buses, to be considered accessible by regulations issued by the Department of Transportation in 49 CFR part 37, shall comply with this subpart.



(b) Over-the-road buses covered by 49 CFR 37.7(c) shall comply with § 1192.23 and this subpart.

**§ 1192.153 Doors, steps and thresholds.**

(a) Floor surfaces on aisles, step treads and areas where wheelchair and mobility aid users are to be accommodated shall be slip-resistant.

(b) All step edges shall have a band of color(s) running the full width of the step which contrasts from the step tread and riser, either dark-on-light or light-on-dark.

(c)(1) Doors shall have a minimum clear width when open of 30 inches (760 mm), measured from the lowest step to a height of at least 48 inches (1220 mm), from which point they may taper to a minimum width of 18 inches (457 mm). The clear width may be reduced by a maximum of 4 inches (100 mm) by protrusions of hinges or other operating mechanisms.

(2) *Exception.* Where compliance with the door width requirement of paragraph (c)(1) of this section is not feasible, the minimum door width shall be 27 in (685 mm).

(d) The overhead clearance between the top of the lift door opening and the sill shall be the maximum practicable but not less than 65 inches (1651 mm).

[56 FR 45558, Sept. 6, 1991, as amended at 63 FR 51698, 51702, Sept. 28, 1998]

**§ 1192.155 Interior circulation, handrails and stanchions.**

(a) Handrails and stanchions shall be provided in the entrance to the vehicle in a configuration which allows passengers to grasp such assists from outside the vehicle while starting to board, and to continue using such handrails or stanchions throughout the boarding process. Handrails shall have a cross-sectional diameter between 1¼ inches and 1½ inches or shall provide an equivalent grasping surface, and have eased edges with corner radii of not less than ⅛ inch. Handrails shall be placed to provide a minimum 1½ inches knuckle clearance from the nearest adjacent surface. Where on-board fare collection devices are used, a horizontal passenger assist shall be located between boarding passengers and the fare collection device and shall prevent passengers from sustaining injuries on

the fare collection device or windshield in the event of a sudden deceleration. Without restricting the vestibule space, the assist shall provide support for a boarding passenger from the door through the boarding procedure. Passengers shall be able to lean against the assist for security while paying fares.

(b) Where provided within passenger compartments, handrails or stanchions shall be sufficient to permit safe on-board circulation, seating and standing assistance, and alighting by persons with disabilities.

**§ 1192.157 Lighting.**

(a) Any stepwell or doorway immediately adjacent to the driver shall have, when the door is open, at least 2 foot-candles of illumination measured on the step tread.

(b) The vehicle doorway shall have outside light(s) which, when the door is open, provide at least 1 foot-candle of illumination on the pathway to the door for a distance of 3 feet (915 mm) to the bottom step tread or lift outer edge. Such light(s) shall be shielded to protect the eyes of entering and exiting passengers.

[56 FR 45558, Sept. 6, 1991, as amended at 63 FR 51698, 51702, Sept. 28, 1998]

**§ 1192.159 Mobility aid accessibility.**

(a)(1) *General.* All vehicles covered by this subpart shall provide a level-change mechanism or boarding device (e.g., lift or ramp) complying with paragraph (b) or (c) of this section and sufficient clearances to permit a wheelchair or other mobility aid user to reach a securement location. At least two securement locations and devices, complying with paragraph (d) of this section, shall be provided.

(2) *Exception.* If portable or station-based lifts, ramps or bridge plates meeting the applicable requirements of this section are provided at stations or other stops required to be accessible under regulations issued by the Department of Transportation, the bus is not required to be equipped with a vehicle-borne device.

(b) *Vehicle lift—(1) Design load.* The design load of the lift shall be at least 600 pounds (2665 N). Working parts, such as cables, pulleys, and shafts,

which can be expected to wear, and upon which the lift depends for support of the load, shall have a safety factor of at least six, based on the ultimate strength of the material. Nonworking parts, such as platform, frame and attachment hardware which would not be expected to wear, shall have a safety factor of at least three, based on the ultimate strength of the material.

(2) *Controls*—(i) *Requirements*. The controls shall be interlocked with the vehicle brakes, transmission, or door, or shall provide other appropriate mechanisms or systems, to ensure that the vehicle cannot be moved when the lift is not stowed and so the lift cannot be deployed unless the interlocks or systems are engaged. The lift shall deploy to all levels (i.e., ground, curb, and intermediate positions) normally encountered in the operating environment. Where provided, each control for deploying, lowering, raising, and stowing the lift and lowering the roll-off barrier shall be of a momentary contact type requiring continuous manual pressure by the operator and shall not allow improper lift sequencing when the lift platform is occupied. The controls shall allow reversal of the lift operation sequence, such as raising or lowering a platform that is part way down, without allowing an occupied platform to fold or retract into the stowed position.

(ii) *Exception*. Where the lift is designed to deploy with its long dimension parallel to the vehicle axis and which pivots into or out of the vehicle while occupied (i.e., “rotary lift”), the requirements of this paragraph (b)(2) prohibiting the lift from being stowed while occupied shall not apply if the stowed position is within the passenger compartment and the lift is intended to be stowed while occupied.

(3) *Emergency operation*. The lift shall incorporate an emergency method of deploying, lowering to ground level with a lift occupant, and raising and stowing the empty lift if the power to the lift fails. No emergency method, manual or otherwise, shall be capable of being operated in a manner that could be hazardous to the lift occupant or to the operator when operated according to manufacturer’s instructions, and shall not permit the platform to be

stowed or folded when occupied, unless the lift is a rotary lift and is intended to be stowed while occupied.

(4) *Power or equipment failure*. Platforms stowed in a vertical position, and deployed platforms when occupied, shall have provisions to prevent their deploying, falling, or folding any faster than 12 inches/second (305 mm/sec) or their dropping of an occupant in the event of a single failure of any load carrying component.

(5) *Platform barriers*. The lift platform shall be equipped with barriers to prevent any of the wheels of a wheelchair or mobility aid from rolling off the platform during its operation. A movable barrier or inherent design feature shall prevent a wheelchair or mobility aid from rolling off the edge closest to the vehicle until the platform is in its fully raised position. Each side of the lift platform which extends beyond the vehicle in its raised position shall have a barrier a minimum 1½ inches (13 mm) high. Such barriers shall not interfere with maneuvering into or out of the aisle. The loading-edge barrier (outer barrier) which functions as a loading ramp when the lift is at ground level, shall be sufficient when raised or closed, or a supplementary system shall be provided, to prevent a power wheelchair or mobility aid from riding over or defeating it. The outer barrier of the lift shall automatically raise or close, or a supplementary system shall automatically engage, and remain raised, closed, or engaged at all times that the platform is more than 3 inches (75 mm) above the roadway or sidewalk and the platform is occupied. Alternatively, a barrier or system may be raised, lowered, opened, closed, engaged, or disengaged by the lift operator, provided an interlock or inherent design feature prevents the lift from rising unless the barrier is raised or closed or the supplementary system is engaged.

(6) *Platform surface*. The platform surface shall be free of any protrusions of ¼ inch (6.5 mm) high and shall be slip resistant. The platform shall have a minimum clear width of 28½ inches (725 mm) at the platform, a minimum clear width of 30 inches (760 mm) measured from 2 inches (50 mm) above the platform surface to 30 inches (760 mm)

above the platform, and a minimum clear length of 48 inches (1220 mm) measured from 2 inches (50 mm) above the surface of the platform to 30 inches (760 mm) above the surface of the platform. (See Figure 1 to this part.)

(7) *Platform gaps.* Any openings between the platform surface and the raised barriers shall not exceed  $\frac{5}{8}$  inch (16 mm) in width. When the platform is at vehicle floor height with the inner barrier (if applicable) down or retracted, gaps between the forward lift platform edge and the vehicle floor shall not exceed  $\frac{1}{2}$  inch (13 mm) horizontally and  $\frac{5}{8}$  inch (16 mm) vertically. Platforms on semi-automatic lifts may have a hand hold not exceeding  $1\frac{1}{2}$  inches (28 mm) by  $4\frac{1}{2}$  inches (113 mm) located between the edge barriers.

(8) *Platform entrance ramp.* The entrance ramp, or loading-edge barrier used as a ramp, shall not exceed a slope of 1:8, measured on level ground, for a maximum rise of 3 inches (75 mm), and the transition from roadway or sidewalk to ramp may be vertical without edge treatment up to  $\frac{1}{4}$  inch (6.5 mm). Thresholds between  $\frac{1}{4}$  inch (6.5 mm) and  $\frac{1}{2}$  inch (13 mm) high shall be beveled with a slope no greater than 1:2.

(9) *Platform deflection.* The lift platform (not including the entrance ramp) shall not deflect more than 3 degrees (exclusive of vehicle roll or pitch) in any direction between its unloaded position and its position when loaded with 600 pounds (2665 N) applied through a 26 inch (660 mm) by 26 inch test pallet at the centroid of the platform.

(10) *Platform movement.* No part of the platform shall move at a rate exceeding 6 inches/second (150 mm/sec) during lowering and lifting an occupant, and shall not exceed 12 inches/second (300 mm/sec) during deploying or stowing. This requirement does not apply to the deployment or stowage cycles of lifts that are manually deployed or stowed. The maximum platform horizontal and vertical acceleration when occupied shall be 0.3g.

(11) *Boarding direction.* The lift shall permit both inboard and outboard facing of wheelchair and mobility aid users.

(12) *Use by standees.* Lifts shall accommodate persons using walkers,

crutches, canes or braces or who otherwise have difficulty using steps. The platform may be marked to indicate a preferred standing position.

(13) *Handrails.* Platforms on lifts shall be equipped with handrails on two sides, which move in tandem with the lift, and which shall be graspable and provide support to standees throughout the entire lift operation. Handrails shall have a usable component at least 8 inches (200 mm) long with the lowest portion a minimum 30 inches (760 mm) above the platform and the highest portion a maximum 38 inches (965 mm) above the platform. The handrails shall be capable of withstanding a force of 100 pounds (445 N) concentrated at any point on the handrail without permanent deformation of the rail or its supporting structure. The handrail shall have a cross-sectional diameter between  $1\frac{1}{4}$  inches (32 mm) and  $1\frac{1}{2}$  inches (38 mm) or shall provide an equivalent grasping surface, and have eased edges with corner radii of not less than  $\frac{3}{8}$  inch (3.5 mm). Handrails shall be placed to provide a minimum  $1\frac{1}{2}$  inches (38 mm) knuckle clearance from the nearest adjacent surface. Handrails shall not interfere with wheelchair or mobility aid maneuverability when entering or leaving the vehicle.

(c) *Vehicle ramp—(1) Design load.* Ramps 30 inches (760 mm) or longer shall support a load of 600 pounds (2665 N), placed at the centroid of the ramp distributed over an area of 26 inches by 26 inches (660 mm by 660 mm), with a safety factor of at least 3 based on the ultimate strength of the material. Ramps shorter than 30 inches (760 mm) shall support a load of 300 pounds (1332 N).

(2) *Ramp surface.* The ramp surface shall be continuous and slip resistant; shall not have protrusions from the surface greater than  $\frac{1}{4}$  inch (6.5 mm) high; shall have a clear width of 30 inches (760 mm); and shall accommodate both four-wheel and three-wheel mobility aids.

(3) *Ramp threshold.* The transition from roadway or sidewalk and the transition from vehicle floor to the ramp may be vertical without edge treatment up to  $\frac{1}{4}$  inch (6.5 mm). Changes in level between  $\frac{1}{4}$  inch (6.5

mm) and ½ inch (13 mm) shall be beveled with a slope no greater than 1:2.

(4) *Ramp barriers.* Each side of the ramp shall have barriers at least 2 inches (50 mm) high to prevent mobility aid wheels from slipping off.

(5) *Slope.* Ramps shall have the least slope practicable and shall not exceed 1:4 when deployed to ground level. If the height of the vehicle floor from which the ramp is deployed is 3 inches (75 mm) or less above a 6 inch (150 mm) curb, a maximum slope of 1:4 is permitted; if the height of the vehicle floor from which the ramp is deployed is 6 inches (150 mm) or less, but greater than 3 inches (75 mm), above a 6 inch (150 mm) curb, a maximum slope of 1:6 is permitted; if the height of the vehicle floor from which the ramp is deployed is 9 inches (225 mm) or less, but greater than 6 inches (150 mm), above a 6 inch curb, a maximum slope of 1:8 is permitted; if the height of the vehicle floor from which the ramp is deployed is greater than 9 inches (225 mm) above a 6 inch (150 mm) curb, a slope of 1:12 shall be achieved. Folding or telescoping ramps are permitted provided they meet all structural requirements of this section.

(6) *Attachment.* When in use for boarding or alighting, the ramp shall be firmly attached to the vehicle so that it is not subject to displacement when loading or unloading a heavy power mobility aid and that no gap between vehicle and ramp exceeds ⅜ inch (16 mm).

(7) *Stowage.* A compartment, securement system, or other appropriate method shall be provided to ensure that stowed ramps, including portable ramps stowed in the passenger area, do not impinge on a passenger's wheelchair or mobility aid or pose any hazard to passengers in the event of a sudden stop or maneuver.

(8) *Handrails.* If provided, handrails shall allow persons with disabilities to grasp them from outside the vehicle while starting to board, and to continue to use them throughout the boarding process, and shall have the top between 30 inches (760 mm) above the ramp surface. The handrails shall be capable of withstanding a force of 100 pounds (445 N) concentrated at any point on the handrail without perma-

nent deformation of the rail or its supporting structure. The handrail shall have a cross-sectional diameter between 1¼ inches (32 mm) and 1½ inches (38 mm) or shall provide an equivalent grasping surface, and have eased edges with corner radii of not less than ⅛ inch (3.5 mm). Handrails shall not interfere with wheelchair or mobility aid maneuverability when entering or leaving the vehicle.

(d) *Securement devices—(1) Design load.* Securement systems, and their attachments to vehicles, shall restrain a force in the forward longitudinal direction of up to 2,000 pounds (8,880 N) per securement leg or clamping mechanism and a minimum of 4,000 pounds (17,760 N) for each mobility aid.

(2) *Location and size.* The securement system shall be placed as near to the accessible entrance as practicable and shall have a clear floor area of 30 inches (760 mm) by 48 inches (1220 mm). Such space shall adjoin, and may overlap, an access path. Not more than 6 inches (150 mm) of the required clear floor space may be accommodated for footrests under another seat, modesty panel, or other fixed element provided there is a minimum of 9 inches (230 mm) from the floor to the lowest part of the seat overhanging the space. Securement areas may have fold-down seats to accommodate other passengers when a wheelchair or mobility aid is not occupying the area, provided the seats, when folded up, do not obstruct the clear floor space required. (See Figure 2 to this part.)

(3) *Mobility aids accommodated.* The securement system shall secure common wheelchairs and mobility aids and shall either be automatic or easily attached by a person familiar with the system and mobility aid and having average dexterity.

(4) *Orientation.* At least one securement device or system required by paragraph (a) of this section shall secure the wheelchair or mobility aid facing toward the front of the vehicle. Additional securement devices or systems shall secure the wheelchair or mobility aid facing forward or rearward. Where the wheelchair or mobility aid is secured facing the rear of the vehicle, a padded barrier shall be provided. The padded barrier shall extend

from a height of 38 inches (965 mm) from the vehicle floor to a height of 56 inches (1420 mm) from the vehicle floor with a width of 18 inches (455 mm), laterally centered immediately in back of the seated individual. Such barriers need not be solid provided equivalent protection is afforded.

(5) *Movement.* When the wheelchair or mobility aid is secured in accordance with manufacturer's instructions, the securement system shall limit the movement of an occupied wheelchair or mobility aid to no more than 2 inches (50 mm) in any direction under normal vehicle operating conditions.

(6) *Stowage.* When not being used for securement, or when the securement area can be used by standees, the securement system shall not interfere with passenger movement, shall not present any hazardous condition, shall be reasonably protected from vandalism, and shall be readily accessed when needed for use.

(7) *Seat belt and shoulder harness.* For each wheelchair or mobility aid securement device provided, a passenger seat belt and shoulder harness, complying with all applicable provisions of the Federal Motor Vehicle Safety Standards (49 CFR part 571), shall also be provided for use by wheelchair or mobility aid users. Such seat belts and shoulder harnesses shall not be used in lieu of a device which secures the wheelchair or mobility aid itself.

[63 FR 51698, 51702, Sept. 28, 1998]

#### § 1192.161 Moveable aisle armrests.

A minimum of 50% of aisle seats, including all moveable or removable seats at wheelchair or mobility aide securement locations, shall have an armrest on the aisle side which can be raised, removed, or retracted to permit easy entry or exit.

[63 FR 51700, 51702, Sept. 28, 1998]

### Subpart H—Other Vehicles and Systems

#### § 1192.171 General.

(a) New, used and remanufactured vehicles and conveyances for systems not covered by other subparts of this part, to be considered accessible by regulations issued by the Department of

Transportation in 49 CFR part 37, shall comply with this subpart.

(b) If portions of the vehicle or conveyance are modified in a way that affects or could affect accessibility, each such portion shall comply, to the extent practicable, with the applicable provisions of this subpart. This provision does not require that inaccessible vehicles be retrofitted with lifts, ramps or other boarding devices.

(c) Requirements for vehicles and systems not covered by this part shall be determined on a case-by-case basis by the Department of Transportation in consultation with the U.S. Architectural and Transportation Barriers Compliance Board (Access Board).

#### § 1192.173 Automated guideway transit vehicles and systems.

(a) Automated Guideway Transit (AGT) vehicles and systems, sometimes called "people movers", operated in airports and other areas where AGT vehicles travel at slow speed, shall comply with the provisions of §§ 1192.53 (a) through (c), and 1192.55 through 1192.61 for rapid rail vehicles and systems.

(b) Where the vehicle covered by paragraph (a) of this section will operate in an accessible station, the design of vehicles shall be coordinated with the boarding platform design such that the horizontal gap between a vehicle door at rest and the platform shall be no greater than 1 inch and the height of the vehicle floor shall be within plus or minus ½ inch of the platform height under all normal passenger load conditions. Vertical alignment may be accomplished by vehicle air suspension or other suitable means of meeting the requirement.

(c) In stations where open platforms are not protected by platform screens, a suitable device or system shall be provided to prevent, deter or warn individuals from stepping off the platform between cars. Acceptable devices include, but are not limited to, pantograph gates, chains, motion detectors or other appropriate devices.

(d) Light rail and rapid rail AGT vehicles and systems shall comply with subparts D and C of this part, respectively.

**§ 1192.175**

**§ 1192.175 High-speed rail cars, mono-rails and systems.**

(a) All cars for high-speed rail systems, including but not limited to those using “maglev” or high speed steel-wheel-on-steel-rail technology, and monorail systems operating primarily on dedicated rail (i.e., not used by freight trains) or guideway, in which stations are constructed in accordance with subpart C of 49 CFR part 37, shall be designed for high-platform, level boarding and shall comply with § 1192.111(a) for each type of car which is similar to intercity rail, §§ 1192.111(d), 1192.113 (a) through (c) and (e), 1192.115 (a) and (b), 1192.117 (a) and (b), 1192.121 through 1192.123, 1192.125(d), and 1192.127 (if applicable). The design of cars shall be coordinated with the boarding platform design such that the horizontal gap between a car door at rest and the platform shall be no greater than 3 inches and the height of the car floor shall be within plus or minus  $\frac{3}{8}$  inch of the platform height under all normal passenger load conditions. Vertical alignment may be accomplished by car air suspension or other suitable means of meeting the requirement. All doorways shall have, when the door is open, at least 2 foot-candles of illumination measured on the door threshold.

(b) All other high-speed rail cars shall comply with the similar provisions of subpart F of this part.

**36 CFR Ch. XI (7–1–03 Edition)**

**§ 1192.177 Ferries, excursion boats and other vessels. [Reserved]**

**§ 1192.179 Trams, similar vehicles and systems.**

(a) New and used trams consisting of a tractor unit, with or without passenger accommodations, and one or more passenger trailer units, including but not limited to vehicles providing shuttle service to remote parking areas, between hotels and other public accommodations, and between and within amusement parks and other recreation areas, shall comply with this section. For purposes of determining applicability of 49 CFR 37.101, 37.103, or 37.105, the capacity of such a vehicle or “train” shall consist of the total combined seating capacity of all units, plus the driver, prior to any modification for accessibility.

(b) Each tractor unit which accommodates passengers and each trailer unit shall comply with §§ 1192.25 and 1192.29. In addition, each such unit shall comply with § 1192.23 (b) or (c) and shall provide at least one space for wheelchair or mobility aid users complying with § 1192.23(d) unless the complete operating unit consisting of tractor and one or more trailers can already accommodate at least two wheelchair or mobility aid users.

FIGURES TO PART 1192

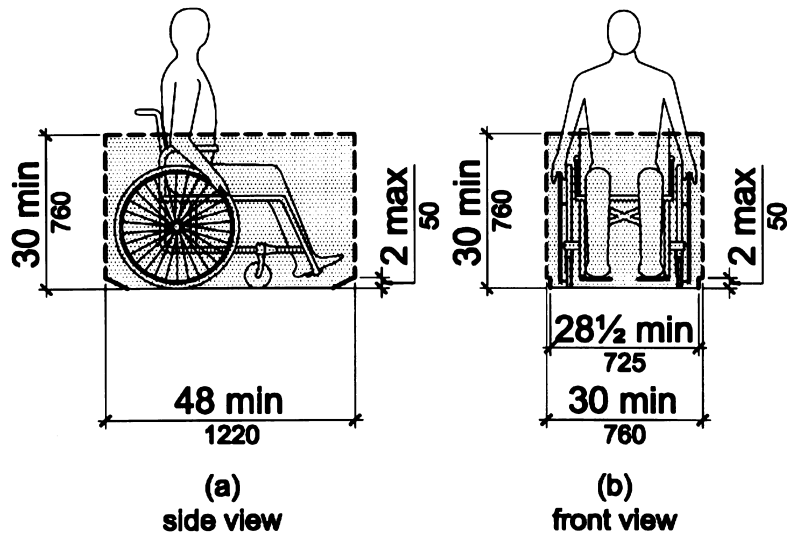

**Figure 1**  
**Wheelchair or Mobility Aid Envelope**

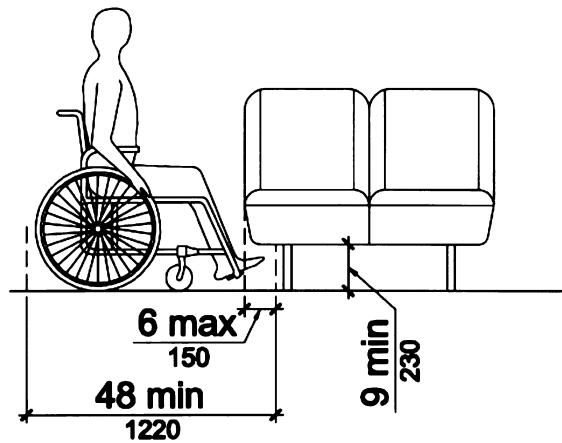

**Figure 2**  
**Toe Clearance Under a Fixed Element**

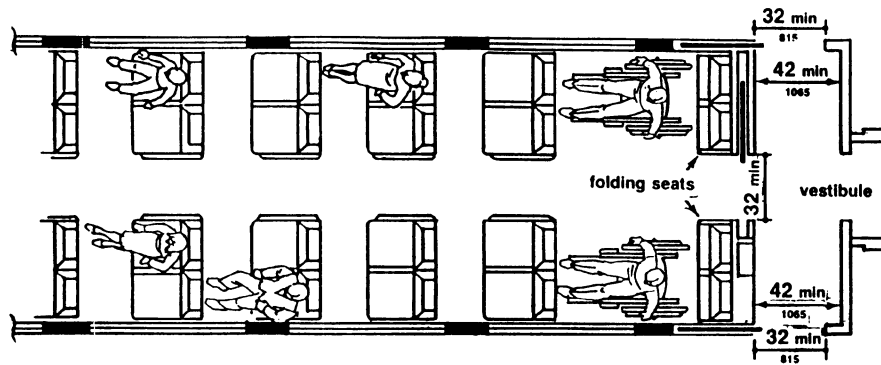

Fig. 3  
Commuter Rail Car (without restrooms)

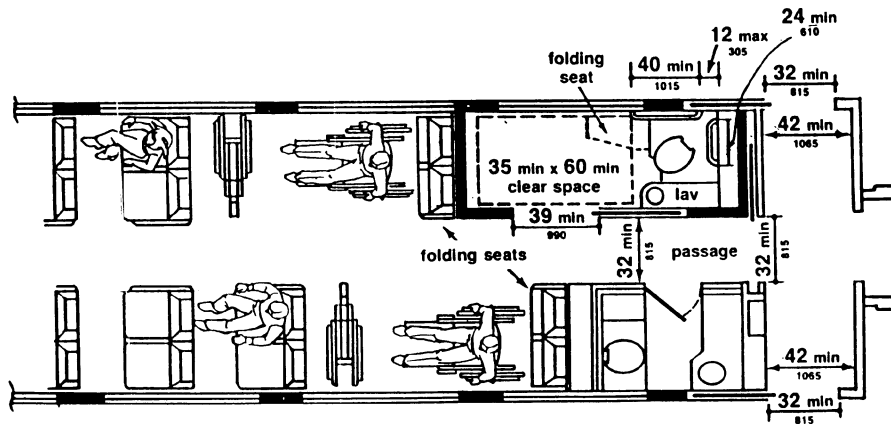

Fig. 4  
Intercity Rail Car (with accessible restroom)



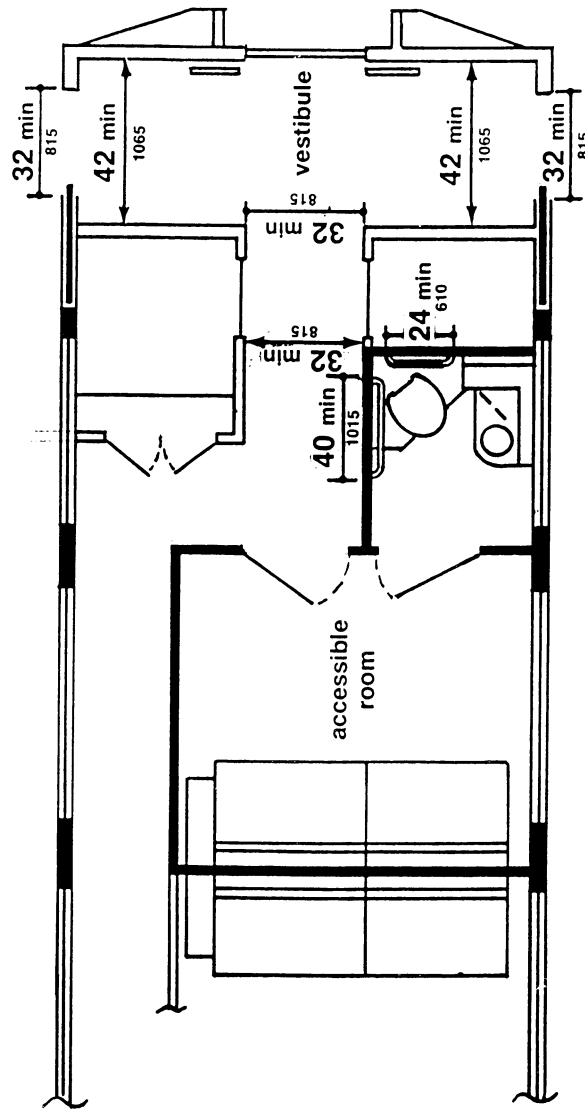
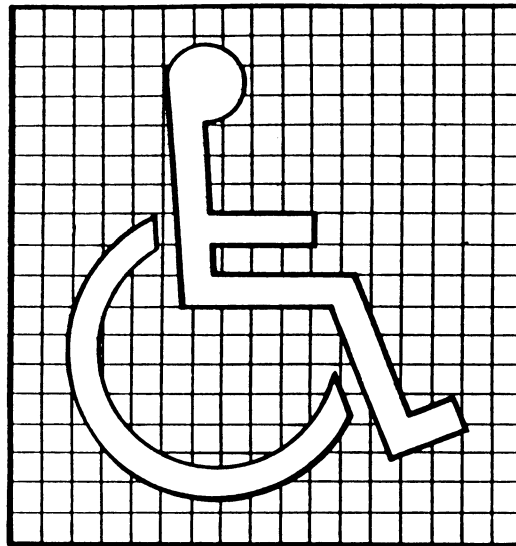

Fig. 5  
Intercity Rail Car (with accessible sleeping compartment)



(a)  
Proportions



(b)  
Display Conditions

**Fig. 6**  
**International Symbol of Accessibility**

APPENDIX TO PART 1192—ADVISORY  
GUIDANCE

This appendix contains materials of an advisory nature and provides additional information that should help the reader to understand the minimum requirements of the guidelines or to design vehicles for greater accessibility. Each entry is applicable to all subparts of this part except where noted. Nothing in this appendix shall in any way obviate any obligation to comply with the requirements of the guidelines themselves.

I. SLIP RESISTANT SURFACES—AISLES, STEPS,  
FLOOR AREAS WHERE PEOPLE WALK, FLOOR  
AREAS IN SECUREMENT LOCATIONS, LIFT  
PLATFORMS, RAMPS

Slip resistance is based on the frictional force necessary to keep a shoe heel or crutch tip from slipping on a walking surface under conditions likely to be found on the surface. While the dynamic coefficient of friction during walking varies in a complex and non-uniform way, the static coefficient of friction, which can be measured in several ways, provides a close approximation of the slip resistance of a surface. Contrary to popular belief, some slippage is necessary to walking, especially for persons with restricted gaits; a

truly "non-slip" surface could not be negotiated.

The Occupational Safety and Health Administration recommends that walking surfaces have a static coefficient of friction of 0.5. A research project sponsored by the Architectural and Transportation Barriers Compliance Board (Access Board) conducted tests with persons with disabilities and concluded that a higher coefficient of friction was needed by such persons. A static coefficient of friction of 0.6 is recommended for steps, floors, and lift platforms and 0.8 for ramps.

The coefficient of friction varies considerably due to the presence of contaminants, water, floor finishes, and other factors not under the control of transit providers and may be difficult to measure. Nevertheless, many common materials suitable for flooring are now labeled with information on the static coefficient of friction. While it may not be possible to compare one product directly with another, or to guarantee a constant measure, transit operators or vehicle designers and manufacturers are encouraged to specify materials with appropriate values. As more products include information on slip resistance, improved uniformity in measurement and specification is likely. The Access Board's advisory guidelines on Slip Resistant Surfaces provides additional information on this subject.

#### II. COLOR CONTRAST—STEP EDGES, LIFT PLATFORM EDGES

The material used to provide contrast should contrast by at least 70%. Contrast in percent is determined by:

$$\text{Contrast} = [(B_1 - B_2) / B_1] \times 100$$

where  $B_1$  = light reflectance value (LRV) of the lighter area  
and  $B_2$  = light reflectance value (LRV) of the darker area.

Note that in any application both white and black are never absolute; thus,  $B_1$  never equals 100 and  $B_2$  is always greater than 0.

#### III. HANDRAILS AND STANCHIONS

In addition to the requirements for handrails and stanchions for rapid, light, and commuter rail vehicles, consideration should be given to the proximity of handrails or stanchions to the area in which wheelchair or mobility aid users may position themselves. When identifying the clear floor space where a wheelchair or mobility aid user can be accommodated, it is suggested that at least one such area be adjacent or in close proximity to a handrail or stanchion. Of course, such a handrail or stanchion cannot encroach upon the required 32 inch width required for the doorway or the route leading to the clear floor space which must be at least 30 by 48 inches in size.

#### IV. PRIORITY SEATING SIGNS AND OTHER SIGNAGE

##### A. Finish and Contrast

The characters and background of signs should be eggshell, matte, or other non-glare finish. An eggshell finish (11 to 19 degree gloss on 60 degree glossimeter) is recommended. Characters and symbols should contrast with their background—either light characters on a dark background or dark characters on a light background. Research indicates that signs are more legible for persons with low vision when characters contrast with their background by at least 70 percent. Contrast in percent is determined by:

$$\text{Contrast} = [(B_1 - B_2) / B_1] \times 100$$

where  $B_1$  = light reflectance value (LRV) of the lighter area  
and  $B_2$  = light reflectance value (LRV) of the darker area.

Note that in any application both white and black are never absolute; thus,  $B_1$  never equals 100 and  $B_2$  is always greater than 0.

The greatest readability is usually achieved through the use of light-colored characters or symbols on a dark background.

##### B. Destination and Route Signs

The following specifications, which are required for buses (§1192.39), are recommended for other types of vehicles, particularly light rail vehicles, where appropriate.

1. Where destination or route information is displayed on the exterior of a vehicle, each vehicle should have illuminated signs on the front and boarding side of the vehicle.

2. Characters on signs covered by paragraph IV.B.1 of this appendix should have a width-to-height ratio between 3:5 and 1:1 and a stroke width-to-height ratio between 1:5 and 1:10, with a minimum character height (using an upper case "X") of 1 inch for signs on the boarding side and a minimum character height of 2 inches for front "headsigs", with "wide" spacing (generally, the space between letters shall be  $\frac{1}{16}$  the height of upper case letters), and should contrast with the background, either dark-on-light or light-on-dark, or as recommended above.

##### C. Designation of Accessible Vehicles

The International Symbol of Accessibility should be displayed as shown in Figure 6.

#### V. PUBLIC INFORMATION SYSTEMS

There is currently no requirement that vehicles be equipped with an information system which is capable of providing the same or equivalent information to persons with hearing loss. While the Department of Transportation assesses available and soon-to-be

available technology during a study to be conducted during Fiscal Year 1992, entities are encouraged to employ whatever services, signage or alternative systems or devices that provide equivalent access and are available. Two possible types of devices are visual display systems and listening systems. However, it should be noted that while visual display systems accommodate persons who are deaf or are hearing impaired, assistive listening systems aid only those with a partial loss of hearing.

#### A. Visual Display Systems

Announcements may be provided in a visual format by the use of electronic message boards or video monitors.

Electronic message boards using a light emitting diode (LED) or "flip-dot" display are currently provided in some transit stations and terminals and may be usable in vehicles. These devices may be used to provide real time or pre-programmed messages; however, real time message displays require the availability of an employee for keyboard entry of the information to be announced.

Video monitor systems, such as visual paging systems provided in some airports (e.g., Baltimore-Washington International Airport), are another alternative. The Architectural and Transportation Barriers Compliance Board (Access Board) can provide technical assistance and information on these systems ("Airport TDD Access: Two Case Studies," (1990)).

#### B. Assistive Listening Systems

Assistive listening systems (ALS) are intended to augment standard public address and audio systems by providing signals which can be received directly by persons with special receivers or their own hearing aids and which eliminate or filter background noise. Magnetic induction loops, infra-red and radio frequency systems are types of listening systems which are appropriate for various applications.

An assistive listening-system appropriate for transit vehicles, where a group of persons or where the specific individuals are not known in advance, may be different from the system appropriate for a particular individual provided as an auxiliary aid or as part of a reasonable accommodation. The appropriate device for an individual is the type that individual can use, whereas the appropriate system for a station or vehicle will necessarily be geared toward the "average" or aggregate needs of various individuals. Earphone jacks with variable volume controls can benefit only people who have slight hearing loss and do not help people who use hearing aids. At the present time, magnetic induction loops are the most feasible type of listening system for people who use hearing aids equipped with "T-coils", but people

without hearing aids or those with hearing aids not equipped with inductive pick-ups cannot use them without special receivers. Radio frequency systems can be extremely effective and inexpensive. People without hearing aids can use them, but people with hearing aids need a special receiver to use them as they are presently designed. If hearing aids had a jack to allow a by-pass of microphones, then radio frequency systems would be suitable for people with and without hearing aids. Some listening systems may be subject to interference from other equipment and feedback from hearing aids of people who are using the systems. Such interference can be controlled by careful engineering design that anticipates feedback sources in the surrounding area.

The Architectural and Transportation Barriers Compliance Board (Access Board) has published a pamphlet on Assistive Listening Systems which lists demonstration centers across the country where technical assistance can be obtained in selecting and installing appropriate systems. The state of New York has also adopted a detailed technical specification which may be useful.

### VI. OVER-THE-ROAD BUSES

#### A. Door Width

Achieving a 30 inch wide front door on an over-the-road bus is considered not feasible if doing so would necessitate reduction of the bus approach angle, relocating the front axle rearward, or increasing the bus overall length.

#### B. Restrooms

The following is provided to assist manufacturers and designers to create restrooms which can be used by people with disabilities. These specifications are derived from requirements for rail vehicles and represent compromises between space needed for use and constraints imposed by vehicle dimensions. As a result, some persons with disabilities cannot use a restroom which meets these specifications and operators who do provide such restrooms should provide passengers with disabilities sufficient advance information about design so that those passengers can assess their ability to use them. Designers should provide additional space beyond these minimum specifications whenever possible.

(1) If an accessible restroom is provided, it should be designed so as to allow a person using a wheelchair or mobility aid to enter and use such restroom as specified in paragraphs (1)(a) through (e) of section VI.B of this appendix.

(a) The minimum clear floor area should be 35 inches (890 mm) by 60 inches (1525 mm). Permanently installed fixtures may overlap this area a maximum of 6 inches (150 mm), if

the lowest portion of the fixture is a minimum of 9 inches (230 mm) above the floor, and may overlap a maximum of 19 inches (485 mm), if the lowest portion of the fixture is a minimum of 29 inches (740 mm) above the floor, provided such fixtures do not interfere with access to the water closet. Fold-down or retractable seats or shelves may overlap the clear floor space at a lower height provided they can be easily folded up or moved out of the way.

(b) The height of the water closet should be 17 inches (430 mm) to 19 inches (485 mm) measured to the top of the toilet seat. Seats should not be sprung to return to a lifted position.

(c) A grab bar at least 24 inches (610 mm) long should be mounted behind the water closet, and a horizontal grab bar at least 40 inches (1015 mm) long should be mounted on at least one side wall, with one end not more than 12 inches (305 mm) from the back wall, at a height between 33 inches (840 mm) and 36 inches (915 mm) above the floor.

(d) Faucets and flush controls should be operable with one hand and should not require tight grasping, pinching, or twisting of the wrist. The force required to activate controls should be no greater than 5 lbs (22.2 N). Controls for flush valves should be mounted no more than 44 inches (1120 mm) above the floor.

(e) Doorways on the end of the enclosure, opposite the water closet, should have a minimum clear opening width of 32 inches (815 mm). Door latches and hardware should be operable with one hand and should not require tight grasping, pinching, or twisting of the wrist.

(2) Accessible restrooms should be in close proximity to at least one seating location for persons using mobility aids and should be connected to such a space by an unobstructed path having a minimum width of 32 inches (815 mm).

*C. Visibility Through a Window*

Care should be taken so that the lift does not obscure the vision of the person occupying the securement position.

[56 FR 45558, Sept. 6, 1991, as amended at 63 FR 51702, Sept. 28, 1998]

**PART 1193—TELECOMMUNICATIONS ACT ACCESSIBILITY GUIDELINES**

**Subpart A—General**

- Sec.
- 1193.1 Purpose.
- 1193.2 Scoping.
- 1193.3 Definitions.

**Subpart B—General Requirements**

- 1193.21 Accessibility, usability, and compatibility.
- 1193.23 Product design, development, and evaluation.

**Subpart C—Requirements for Accessibility and Usability**

- 1193.31 Accessibility and usability.
- 1193.33 Information, documentation, and training.
- 1193.35 Redundancy and selectability. [Reserved]
- 1193.37 Information pass through.
- 1193.39 Prohibited reduction of accessibility, usability, and compatibility.
- 1193.41 Input, control, and mechanical functions.
- 1193.43 Output, display, and control functions.

**Subpart D—Requirements for Compatibility With Peripheral Devices and Specialized Customer Premises Equipment**

- 1193.51 Compatibility.

APPENDIX TO PART 1193—ADVISORY GUIDANCE

AUTHORITY: 47 U.S.C. 255(e).

SOURCE: 63 FR 5630, Feb. 3, 1998, unless otherwise noted.

**Subpart A—General**

**§ 1193.1 Purpose.**

This part provides requirements for accessibility, usability, and compatibility of telecommunications equipment and customer premises equipment covered by the Telecommunications Act of 1996 (47 U.S.C. 255).

**§ 1193.2 Scoping.**

This part provides requirements for accessibility, usability, and compatibility of new products and existing products which undergo substantial change or upgrade, or for which new releases are distributed. This part does not apply to minor or insubstantial changes to existing products that do not affect functionality.

**§ 1193.3 Definitions.**

Terms used in this part shall have the specified meaning unless otherwise stated. Words, terms and phrases used in the singular include the plural, and use of the plural includes the singular.

*Accessible.* Telecommunications equipment or customer premises equipment which comply with the requirements of subpart C of this part.

*Alternate formats.* Alternate formats may include, but are not limited to, Braille, ASCII text, large print, and audio cassette recording.

*Alternate modes.* Different means of providing information to users of products including product documentation and information about the status or operation of controls. Examples of alternate modes may include, but are not limited to, voice, fax, relay service, TTY, Internet posting, captioning, text-to-speech synthesis, and video description.

*Compatible.* Telecommunications equipment or customer premises equipment which comply with the requirements of subpart D of this part.

*Customer premises equipment.* Equipment employed on the premises of a person (other than a carrier) to originate, route, or terminate telecommunications.

*Manufacturer.* A manufacturer of telecommunications equipment or customer premises equipment that sells to the public or to vendors that sell to the public; a final assembler.

*Peripheral devices.* Devices employed in connection with telecommunications equipment or customer premises equipment to translate, enhance, or otherwise transform telecommunications into a form accessible to individuals with disabilities.

*Product.* Telecommunications equipment or customer premises equipment.

*Readily achievable.* Easily accomplishable and able to be carried out without much difficulty or expense.

*Specialized customer premises equipment.* Equipment, employed on the premises of a person (other than a carrier) to originate, route, or terminate telecommunications, which is commonly used by individuals with disabilities to achieve access.

*Telecommunications.* The transmission, between or among points specified by the user, of information of the user's choosing, without change in the form or content of the information as sent and received.

*Telecommunications equipment.* Equipment, other than customer premises

equipment, used by a carrier to provide telecommunications services, and includes software integral to such equipment (including upgrades).

*Telecommunications service.* The offering of telecommunications for a fee directly to the public, or to such classes of users as to be effectively available directly to the public, regardless of the facilities used.

*TTY.* An abbreviation for teletypewriter. Machinery or equipment that employs interactive text based communications through the transmission of coded signals across the standard telephone network. TTYs can include, for example, devices known as TDDs (telecommunication display devices or telecommunication devices for deaf persons) or computers with special modems. TTYs are also called text telephones.

*Usable.* Means that individuals with disabilities have access to the full functionality and documentation for the product, including instructions, product information (including accessible feature information), documentation, and technical support functionally equivalent to that provided to individuals without disabilities.

## Subpart B—General Requirements

### § 1193.21 Accessibility, usability, and compatibility.

Where readily achievable, telecommunications equipment and customer premises equipment shall comply with the requirements of subpart C of this part. Where it is not readily achievable to comply with subpart C of this part, telecommunications equipment and customer premises equipment shall comply with the requirements of subpart D of this part, if readily achievable.

### § 1193.23 Product design, development, and evaluation.

(a) Manufacturers shall evaluate the accessibility, usability, and compatibility of telecommunications equipment and customer premises equipment and shall incorporate such evaluation throughout product design, development, and fabrication, as early

and consistently as possible. Manufacturers shall identify barriers to accessibility and usability as part of such a product design and development process.

(b) In developing such a process, manufacturers shall consider the following factors, as the manufacturer deems appropriate:

(1) Where market research is undertaken, including individuals with disabilities in target populations of such research;

(2) Where product design, testing, pilot demonstrations, and product trials are conducted, including individuals with disabilities in such activities;

(3) Working cooperatively with appropriate disability-related organizations; and

(4) Making reasonable efforts to validate any unproven access solutions through testing with individuals with disabilities or with appropriate disability-related organizations that have established expertise with individuals with disabilities.

**Subpart C—Requirements for Accessibility and Usability**

**§ 1193.31 Accessibility and usability.**

When required by §1193.21, telecommunications equipment and customer premises equipment shall be accessible to and usable by individuals with disabilities and shall comply with §§1193.33 through 1193.43 as applicable.

**§ 1193.33 Information, documentation, and training.**

(a) Manufacturers shall ensure access to information and documentation it provides to its customers. Such information and documentation includes user guides, installation guides for end-user installable devices, and product support communications, regarding both the product in general and the accessibility features of the product. Manufacturers shall take such other steps as necessary including:

(1) Providing a description of the accessibility and compatibility features of the product upon request, including, as needed, in alternate formats or alternate modes at no additional charge;

(2) Providing end-user product documentation in alternate formats or al-

ternate modes upon request at no additional charge; and

(3) Ensuring usable customer support and technical support in the call centers and service centers which support their products at no additional charge.

(b) Manufacturers shall include in general product information the contact method for obtaining the information required by paragraph (a) of this section.

(c) Where manufacturers provide employee training, they shall ensure it is appropriate to an employee's function. In developing, or incorporating existing training programs, consideration shall be given to the following factors:

(1) Accessibility requirements of individuals with disabilities;

(2) Means of communicating with individuals with disabilities;

(3) Commonly used adaptive technology used with the manufacturer's products;

(4) Designing for accessibility; and

(5) Solutions for accessibility and compatibility.

**§ 1193.35 Redundancy and selectability. [Reserved]**

**§ 1193.37 Information pass through.**

Telecommunications equipment and customer premises equipment shall pass through cross-manufacturer, non-proprietary, industry-standard codes, translation protocols, formats or other information necessary to provide telecommunications in an accessible format. In particular, signal compression technologies shall not remove information needed for access or shall restore it upon decompression.

**§ 1193.39 Prohibited reduction of accessibility, usability, and compatibility.**

(a) No change shall be undertaken which decreases or has the effect of decreasing the net accessibility, usability, or compatibility of telecommunications equipment or customer premises equipment.

(b) Exception: Discontinuation of a product shall not be prohibited.

**§ 1193.41 Input, control, and mechanical functions.**

Input, control, and mechanical functions shall be locatable, identifiable,

§ 1193.43

36 CFR Ch. XI (7-1-03 Edition)

and operable in accordance with each of the following, assessed independently:

(a) *Operable without vision.* Provide at least one mode that does not require user vision.

(b) *Operable with low vision and limited or no hearing.* Provide at least one mode that permits operation by users with visual acuity between 20/70 and 20/200, without relying on audio output.

(c) *Operable with little or no color perception.* Provide at least one mode that does not require user color perception.

(d) *Operable without hearing.* Provide at least one mode that does not require user auditory perception.

(e) *Operable with limited manual dexterity.* Provide at least one mode that does not require user fine motor control or simultaneous actions.

(f) *Operable with limited reach and strength.* Provide at least one mode that is operable with user limited reach and strength.

(g) *Operable without time-dependent controls.* Provide at least one mode that does not require a response time. Alternatively, a response time may be required if it can be by-passed or adjusted by the user over a wide range.

(h) *Operable without speech.* Provide at least one mode that does not require user speech.

(i) *Operable with limited cognitive skills.* Provide at least one mode that minimizes the cognitive, memory, language, and learning skills required of the user.

**§ 1193.43 Output, display, and control functions.**

All information necessary to operate and use the product, including but not limited to, text, static or dynamic images, icons, labels, sounds, or incidental operating cues, shall comply with each of the following, assessed independently:

(a) *Availability of visual information.* Provide visual information through at least one mode in auditory form.

(b) *Availability of visual information for low vision users.* Provide visual information through at least one mode to users with visual acuity between 20/70 and 20/200 without relying on audio.

(c) *Access to moving text.* Provide moving text in at least one static presentation mode at the option of the user.

(d) *Availability of auditory information.* Provide auditory information through at least one mode in visual form and, where appropriate, in tactile form.

(e) *Availability of auditory information for people who are hard of hearing.* Provide audio or acoustic information, including any auditory feedback tones that are important for the use of the product, through at least one mode in enhanced auditory fashion (i.e., increased amplification, increased signal-to-noise ratio, or combination). For transmitted voice signals, provide a gain adjustable up to a minimum of 20 dB. For incremental volume control, provide at least one intermediate step of 12 dB of gain.

(f) *Prevention of visually-induced seizures.* Visual displays and indicators shall minimize visual flicker that might induce seizures in people with photosensitive epilepsy.

(g) *Availability of audio cutoff.* Where a product delivers audio output through an external speaker, provide an industry standard connector for headphones or personal listening devices (e.g., phone-like handset or earcup) which cuts off the speaker(s) when used.

(h) *Non-interference with hearing technologies.* Reduce interference to hearing technologies (including hearing aids, cochlear implants, and assistive listening devices) to the lowest possible level that allows a user to utilize the product.

(i) *Hearing aid coupling.* Where a product delivers output by an audio transducer which is normally held up to the ear, provide a means for effective wireless coupling to hearing aids.

**Subpart D—Requirements for Compatibility With Peripheral Devices and Specialized Customer Premises Equipment**

**§ 1193.51 Compatibility.**

When required by subpart B of this part, telecommunications equipment and customer premises equipment shall be compatible with peripheral devices and specialized customer premises



equipment commonly used by individuals with disabilities to achieve accessibility, and shall comply with the following provisions, as applicable:

(a) *External electronic access to all information and control mechanisms.* Information needed for the operation of products (including output, alerts, icons, on-line help, and documentation) shall be available in a standard electronic text format on a cross-industry standard port and all input to and control of a product shall allow for real time operation by electronic text input into a cross-industry standard external port and in cross-industry standard format. The cross-industry standard port shall not require manipulation of a connector by the user.

(b) *Connection point for external audio processing devices.* Products providing auditory output shall provide the auditory signal at a standard signal level through an industry standard connector.

(c) *Compatibility of controls with prosthetics.* Touchscreen and touch-operated controls shall be operable without requiring body contact or close body proximity.

(d) *TTY connectability.* Products which provide a function allowing voice communication and which do not themselves provide a TTY functionality shall provide a standard non-acoustic connection point for TTYs. It shall also be possible for the user to easily turn any microphone on and off to allow the user to intermix speech with TTY use.

(e) *TTY signal compatibility.* Products, including those providing voice communication functionality, shall support use of all cross-manufacturer non-proprietary standard signals used by TTYs.

#### APPENDIX TO PART 1193—ADVISORY GUIDANCE

##### INTRODUCTION

1. This appendix provides examples of strategies and notes to assist in understanding the guidelines and are a source of ideas for alternate strategies for achieving accessibility. These strategies and notes are not mandatory. A manufacturer is not required to incorporate all of these examples or any specific example. Manufacturers are free to use these or other strategies in addressing the guidelines. The examples listed

here are not comprehensive, nor does adopting or incorporating them guarantee an accessible product. They are meant to provide a useful starting point for evaluating the accessibility of a product or conceptual design and are not intended to inhibit innovation. For a more complete list of all of the published strategies to date, as well as for further information and links to on-going discussions, the reader is referred to the National Institute on Disability and Rehabilitation Research's Rehabilitation Engineering Center on Access to Telecommunications System's strategies Web site (<http://trace.wisc.edu/world/telecomm/>).

2. This appendix is organized to correspond to the sections and paragraphs of the guidelines in this part to which the explanatory material relates. This appendix does not contain explanatory material for every section and paragraph of the guidelines in this part.

#### SUBPART A—GENERAL

##### Section 1193.3 Definitions

##### Readily Achievable

1. Section 255 defines "readily achievable" as having the same meaning as in the Americans with Disabilities Act (ADA). However, the ADA applies the term to the removal of barriers in existing public accommodations. Not all of the factors cited in the ADA or the Department of Justice (DOJ) implementing regulations (July 26, 1991) are easy to translate to the telecommunications context where the term applies to telecommunications equipment and customer premises equipment which is designed, developed and fabricated after February 8, 1996, the effective date of the Telecommunications Act of 1996.

2. It may not be readily achievable to make every product accessible or compatible. Depending on the design, technology, or several other factors, it may be determined that providing accessibility to all products in a product line is not readily achievable. The guidelines do not require accessibility or compatibility when that determination has been made, and it is up to the manufacturer to make it. However, the assessment as to whether it is or is not readily achievable cannot be bypassed simply because another product is already accessible. For this purpose, two products are considered to be different if they have different functions or features. Products which differ only cosmetically, where such differences do not affect functionality, are not considered separate products.

3. Below is a list of factors provided as interim guidance to manufacturers to assist them in making readily achievable assessments. The factors are derived from the ADA itself and the DOJ regulations and are presented in the order in which they appear in

those sources. Ultimately, the priority or weight of these factors is a compliance issue, under the jurisdiction of the Federal Communications Commission (FCC). Factors applicable to a determination of whether an action is readily achievable include: the nature and cost of the action needed to provide accessibility or compatibility; the overall resources of the manufacturer, including financial resources, technical expertise, component supply sources, equipment, or personnel; the overall financial resources of any parent corporation or entity, only to the extent such resources are available to the manufacturer; and whether the accessibility solution results in a fundamental alteration of the product.

a. One factor in making readily achievable assessments is the nature and cost of the action needed to provide accessibility or compatibility. The term readily achievable means that an action is “easily accomplishable and able to be carried out without much difficulty or expense.” The nature of the action or solution involves how easy it is to accomplish, including the availability of technology and expertise, and the ability to incorporate the solution into the production process. Obviously, knowing about an accessibility solution, even in detail, does not mean it is readily achievable for a specific manufacturer to implement it immediately. Even if it only requires substituting a different, compatible part, the new part must be ordered and integrated into the manufacturing process. A more extreme implementation might require re-tooling or redesign. On the other hand, a given solution might be so similar to the current design, development and fabrication process that it is readily achievable to implement it virtually overnight.

b. Another factor in making readily achievable assessments is the overall resources of the manufacturer, including financial resources, technical expertise, component supply sources, equipment, or personnel. The monetary resources of a manufacturer are obviously a factor in determining whether an action is readily achievable, but it may be appropriate to consider other resources, as well. For example, a company might have ample financial resources and, at first glance, appear to have no reason for not including a particular accessibility feature in a given product. However, it might be that the company lacks personnel with experience in software development, for example, needed to implement the design solution. One might reason that, if the financial resources are available, the company should hire the appropriate personnel, but, if it does, it may no longer have the financial resources to implement the design solution. One would expect that the company would develop the technical expertise over time

and that eventually the access solution might become readily achievable.

c. Another factor in making readily achievable assessments is the overall financial resources of any parent corporation or entity, only to the extent such resources are available to the manufacturer. Both the ADA statutory definition of readily achievable and the DOJ regulations define the resources of a parent company as a factor. However, such resources are considered only to the extent those resources are available to the subsidiary. If, for example, the subsidiary is responsible for product design but the parent company is responsible for overall marketing, it may be appropriate to expect the parent company to address some of the marketing goals. If, on the other hand, the resources of a parent company are not available to the subsidiary, they may not be relevant. This determination would be made on a case-by-case basis.

d. A fourth factor in making readily achievable assessments is whether the accessibility solution results in a fundamental alteration of the product. This factor, derived by extension from the “undue burden” criteria of the ADA, takes into consideration the effect adding an accessibility feature might have on a given product. For example, it may not be readily achievable to add a large display for low vision users to a small pager designed to fit in a pocket, because making the device significantly larger would be a fundamental alteration of the device. On the other hand, adding a voice output may not involve a fundamental alteration and would serve both blind and low vision users. In addition, adding an infrared port might be readily achievable and would allow a large-display peripheral device to be coupled to it. Of course fundamental alteration means a change in the fundamental characteristic of the product, not merely a cosmetic or esthetic change.

#### SUBPART B—GENERAL REQUIREMENTS

##### *Section 1193.23 Product Design, Development and Evaluation*

###### Paragraph (a)

1. This section requires manufacturers to evaluate the accessibility, usability, and compatibility of telecommunications equipment and customer premises equipment and incorporate such evaluation throughout product design, development, and fabrication, as early and consistently as possible. Manufacturers must develop a process to ensure that products are designed, developed and fabricated to be accessible whenever it is readily achievable. Since what is readily achievable will vary according to the stage of development (i.e., some things will be readily achievable in the design phase which

may not be in later phases), barriers to accessibility and usability must be identified throughout product design and development, from conceptualization to production. Moreover, usability can be seriously affected even after production, if information is not provided in an effective manner.

2. The details of such an evaluation process will vary from one company to the next, so this section does not specify its structure or specific content. Instead, this section sets forth a series of factors that a manufacturer must consider in developing such a process. How, and to what extent, each of the factors is incorporated in a specific process is up to the manufacturer.

3. Different manufacturers, or even the same manufacturer at different times, have the flexibility to tailor any such plan to its own particular needs. This section does not prescribe any particular plan or content. It does not require that such a process be submitted to any entity or that it even be in writing. The requirement is outcome-oriented, and a process could range from purely conceptual to formally documented, as suits the manufacturer.

4. The goal is for designers to be aware of access and incorporate such considerations in the conceptualization of new products. When an idea is just beginning to take shape, a designer would ask, "How would a blind person use this product? How would a deaf person use it?" The sooner a manufacturer makes its design team cognizant of design issues for achieving accessibility; and proven solutions for accessibility and compatibility, the easier this process will be.

#### Paragraph (b)(1)

##### Market Research

1. The guidelines do not require market research, testing or consultation, only that they be considered and incorporated to the extent deemed appropriate for a given manufacturer. If a manufacturer has a large marketing effort, involving surveys and focus groups, it may be appropriate to include persons with disabilities in such groups. On the other hand, some small companies do not do any real marketing, per se, but may just notice that a product made by XYZ Corporation is selling well and, based on this "marketing survey" it decides it can make a cheaper one. Clearly, "involvement" of persons with disabilities is not appropriate in this case.

2. A manufacturer must consider how it could include individuals with disabilities in target populations of market research. It is important to realize that any target population for which a manufacturer might wish to focus a product contains individuals with disabilities, whether it is teenagers, single parents, women between the ages of 25 and 40, or any other subgroup, no matter how

narrowly defined. Any market research which excludes individuals with disabilities will be deficient.

#### Paragraph (b)(2)

##### Product Design, Testing, Pilot Demonstrations, and Product Trials

1. Including individuals with disabilities in product design, testing, pilot demonstrations, and product trials will encourage appropriate design solutions to accessibility barriers. In addition, such involvement may result in designs which have an appeal to a broader market.

#### Paragraph (b)(3)

##### Working Cooperatively With Appropriate Disability-Related Organizations

1. Working cooperatively with appropriate disability-related organizations is one of the factors that manufacturers must consider in their product design and development process. The primary reason for working cooperatively is to exchange relevant information. This is a two-way process since the manufacturer will get information on barriers to the use of its products, and may also be alerted to possible sources for solutions. The process will also serve to inform individuals with disabilities about what is readily achievable. In addition, manufacturers will have a conduit to a source of subjects for market research and product trials.

2. Manufacturers should consult with representatives from a cross-section of disability groups, particularly individuals whose disabilities affect hearing, vision, movement, manipulation, speech, and interpretation of information.

3. Because of the complex interrelationship between equipment and services in providing accessibility to telecommunications products, coordination and cooperation between manufacturers and service providers will be beneficial. Involving service providers in the product development process will encourage appropriate design solutions to accessibility barriers and permit the exchange of relevant information.

#### Paragraph (b)(4)

##### Making Reasonable Efforts to Validate Unproven Access Solutions

1. Manufacturers must consider how they can make reasonable efforts to validate any unproven access solutions through testing with individuals with disabilities or with appropriate disability-related organizations that have established expertise with individuals with disabilities. It is important to obtain input from persons or organizations with established expertise to ensure that input is not based merely on individual preferences or limited experience.

2. This input should be sought from representatives from a cross-section of disability groups, particularly individuals whose disabilities affect hearing, vision, movement, manipulation, speech, and interpretation of information.

SUBPART C—REQUIREMENTS FOR  
ACCESSIBILITY AND USABILITY

*Section 1193.33 Information, Documentation,  
and Training*

Paragraph (a)

1. This section requires that manufacturers provide access to information and documentation. The information and documentation includes user guides, installation guides, and product support communications, regarding both the product in general and the accessibility features of the product. Information and documentation should be provided to people with disabilities at no additional charge. Alternate formats or alternate modes of this information is also required to be available. Manufacturers should also encourage distributors of their products to establish information dissemination and technical support programs similar to those established by the manufacturer.

Alternate Formats and Alternate Modes

1. Alternate formats may include, but are not limited to, Braille, ASCII text, large print, and audio cassette recording. Alternate modes may include, but are not limited to, voice, fax, relay service, TTY, Internet posting, captioning, text-to-speech synthesis, and video description.

2. In considering how to best provide product information to people with disabilities, it is essential that information be provided in an alternate format or mode that is usable by the person needing the information. For example, some individuals who are blind might require a manual in Braille to understand and use the product effectively. Other persons who are blind may prefer this information on a computer disk. Persons with limited reading skills may need this information recorded on audio cassette tape so they can listen to the manual. Still other persons with low vision may be able to read the text version of the manual if it is provided in a larger font. Likewise, if a tutorial video is provided, persons who are deaf may require a captioned version so that they will understand how to use the product effectively. Finally, individuals who rely on TTYs will need direct TTY access to a customer service line so they can ask questions about a product like everyone else.

3. This portion of the appendix explains how to provide information in alternate for-

ats (Braille, ASCII text, large print, audio cassette) to persons with disabilities.<sup>1</sup>

Braille

4. Some persons who are blind rely on the use of Braille in order to obtain information that is typically provided in print. These persons may need Braille because of the nature of their disability (such as persons who are deaf-blind) or because of the complexity of the material. Most large urban areas have companies or organizations which can translate printed material to Braille. On the other hand, manufacturers may wish to consider producing Braille documents "in house" using a personal computer, Braille translation software, and a Braille printer. The disadvantage is the difficulty in ensuring quality control and accuracy. Software programs exist which can translate common word processing formats directly into Braille, but they are not always error free, especially if the document contains special characters, jargon, graphics, or charts. Since the typical office worker will not be able to proofread a Braille document, the initial apparent cost saving may be quickly lost by having to re-do documents. The Braille translation software costs approximately \$500 and most Braille printers sold range from \$2,000 to \$5,000, however some Braille printers, depending on the speed and other features, do cost more. Depending on the quality of Braille to be generated, a Braille printer in the \$4,000 range should be adequate for most users. By using automatic translation software, individuals who do not have knowledge of Braille or who have limited computer skills may be able to produce simple Braille documents without much trouble. If the document is of a complex format, however, such as a text box over multiple columns, a sophisticated knowledge of Braille translation software and formatting will be required.

Electronic Text

5. People who are blind or have low vision and who have access to computers may be able to use documents in electronic form. Electronic text must be provided in ASCII or a properly formatted word processor file. Using electronic text allows this information to be transmitted through e-mail or other on-line telecommunications. Blind or low vision persons who have access to a personal computer can then read the document using synthetic speech, an electronic Braille display, a large print computer monitor, or they can produce a hard copy in large print or Braille.

<sup>1</sup>This information was provided by the American Foundation for the Blind.

6. Documents prepared for electronic transmission should be in ASCII. Documents supplied on disk should also be provided in either ASCII or a word processor format usable by the customer. Word processing documents should be properly formatted before distribution or conversion to ASCII. To be correctly formatted, the document should be in Courier 10 point size and formatted for an 80 character line. Tables should be converted to plain text. Graphics or text boxes should be deleted and explained or described in text format. This will allow the reader to understand all of the documentation being presented. Replace bullets (●) with "\*" or "-" and convert other extended ASCII characters into text. When converting a document into ASCII or word processor formats, it is important to utilize the appropriate "tab key" and "centering key" rather than using the space bar. This is necessary because Braille translation software relies on the proper use of commands to automate the formatting of a Braille document.

#### Large Print

7. Persons with low vision may require documentation to be provided in large print. Large print documents can easily be produced using a scalable font from any good word processing program and a standard laser printer. Using the document enlargement option on a photocopier will usually yield unsatisfactory results.

8. To obtain the best results follow these guidelines:

a. It is preferable to use paper that is standard  $8\frac{1}{2} \times 11$  inches. Larger paper may be used, but care should be taken that a document does not become too bulky, thus making it difficult to read. Always use 1 inch margins. Lines longer than  $6\frac{1}{3}$  inches will not track well for individuals who must use a magnifier.

b. The best contrast with the least glare is achieved on very pale yellow or cream-colored non-glossy paper, such as paper that is used for photocopying purposes. To produce a more aesthetic looking document, an off-white paper may be used and will still give good contrast while producing less glare than white. Do not use dark colors and shades of red. Double-sided copying (if print does not bleed through) will produce a less bulky document.

c. Remove formatting codes that can make reading more difficult. For example, centered or indented text could be difficult to track because only a few words will fit on a line. All text should begin at the left margin. Use only left margin justification to maintain uniform spacing across lines. Right margin justification can produce uneven spacing between letters and words. Use  $1\frac{1}{4}$  (1.25) line spacing; do not double space. Replace tabs with two spaces. Page numbering should be at the top or bottom left. Avoid

columns. If columns are absolutely necessary, use minimum space between columns. Use dot leaders for tabular material. For those individuals who are able to read graphics (via the use of a magnifier or other assistive device) graphics should be included, but placed on a separate page from the text. For those individuals with low vision who are unable to read graphics, tables, and charts this material must be removed from the document and an accurate description of this material should be included in a text format.

d. There is no standard typeface or point size. For more universal access, use 18 point type; anything larger could make text too choppy to read comfortably. Use a good strong bold typeface. Do not use italics, fine, or fancy typefaces. Do not use compressed typefaces; there should be normal "white space" between characters.

e. Use upper and lowercase letters.

f. Using these instructions, one page of print (11-12 point type) will equal approximately three pages of large print (14-18 point) depending on the density of the text.

#### Cassette Recordings

9. Some persons who are blind or who have learning disabilities may require documentation on audio cassettes. Audio materials can be produced commercially or in-house. Agencies sometimes record material in-house and purchase a high speed tape duplicator (\$1,000-2,000) which is used to make cassette copies from the master. The cost of a duplicator can be higher depending upon the number of copies produced on a single run, and whether the duplicator can produce standard speed two-sided copies or half-speed four-sided copies. Although unit costs can be reduced by using the four-track, half-speed format, this will require the reader to use a specially designed playback machine. Tapes should be produced with "tone indexing" to allow a user to skip back and forth from one section to another. By following a few simple guidelines for selecting readers and creating recordings, most organizations will be able to successfully record most simple documents.

10. Further guidance in making cassette recordings includes:

a. The reader should be proficient in the language being recorded.

b. The reader should be familiar with the subject. Someone who is somewhat familiar with the technical aspects of a product but who can explain functions in ordinary language would be a logical person to record an audio cassette.

c. The reader should have good diction. Recording should be done in a conversational tone and at a conversational pace; neither too slow nor too fast.

d. The reader should be familiar with the material to minimize stumbling and hesitation.

e. The reader should not editorialize. When recording a document, it should be read in full. Graphic and pictorial information available to sighted readers should be described in the narrated text. Tables and charts whose contents are not already contained in text should be converted into text and included in the recording.

f. The reader should spell difficult or unusual words and words of foreign origin.

g. At the beginning of the tape, identify the reader, i.e., "This document is being read by John Smith."

h. On each side of the tape, identify the document and the page number where the reader is continuing, i.e., "tape 2, side 1, Guide to Barrier Free Meetings, continuing on page 75."

i. For blind users, all cassettes should be labeled in Braille so that they can easily be referenced in the appropriate order.

#### Alternate Modes

11. Information is provided increasingly through a variety of means including television advertisements, Internet postings, information seminars, and telephone. This portion of the appendix explains how to provide information in some alternate modes (captioning, video description, Internet postings, relay service, and TTY).

#### Captioning

12. When manufacturers of telecommunications equipment or customer premises equipment provide videos with their products (such as tutorials or information explaining various components of a product) the video should be available with captioning. Closed captioning refers to assistive technology designed to provide access to television for persons with hearing disabilities that is visible only through the use of a decoder. Open captions are visible at all times. Captioning is similar to subtitles in that the audio portion of a television program is displayed as printed words on the television screen. Captions should be carefully placed to identify speakers, on-and off-screen sound effects, music and laughter. Increased captioning was made possible because of the Television Decoder Circuitry Act which requires all television sets sold in the United States with screens 13 inches or larger to have built-in decoder circuitry.

13. Although captioning technology was developed specifically to make television and video presentations accessible to deaf and hard of hearing people, there has been widespread interest in using this technology to provide similar access to meetings, classroom teaching, and conferences. For meetings, video-conferences, information seminars, and the like, real-time captioning is sometimes provided. Real-time captioning uses a stenographic machine connected to a

computer with translation software. The output is then displayed on a monitor or projected on a screen.

#### Video Description

14. Just as manufacturers of telecommunications equipment and customer premises equipment need to make their videos accessible to persons who are deaf or hard of hearing, they must also be accessible to persons who are blind or have low vision. This process is known as video description. Video description may either be a separate audio track that can be played simultaneously with the regular audio portion of the video material (adding description during pauses in the regular audio), or it can be added to (or "mixed" with) an existing soundtrack. The latter is the technique used for videotapes.

#### Internet Postings

15. The fastest growing way to obtain information about a product is through use of the Internet, and specifically the World Wide Web. However, many Internet users with disabilities have difficulty obtaining this information if it is not correctly formatted. This section provides information on how to make a World Wide Web site more accessible to persons with disabilities<sup>2</sup>. Because of its structure, the Web provides tremendous power and flexibility in presenting information in multiple formats (text, audio, video, and graphic). However, the features that provide power and elegance for some users present potential barriers for people with sensory disabilities. The indiscriminate use of graphic images and video restrict access for people who are blind or have low vision. Use of audio and non-captioned video restrict access for people who are deaf or hard of hearing.

16. The level of accessibility of the information on the Web is dependent on the format of the information, the transmission media, and the display system. Many of the issues related to the transmission media and the display system cannot be affected by the general user. On the other hand, anyone creating information for a Web server has control of the accessibility of the information. Careful design and coding of information will provide access to all people without compromising the power and elegance of the Web site.

17. A few suggestions are:

<sup>2</sup>This information is based on the document "Writing HTML Documents and Implementing Accessibility for the World Wide Web" by Paul Fountaine, Center for Information Technology Accommodation, General Services Administration. For further information, see <http://www.gsa.gov/coca>.

a. Every graphic image should have associated text. This will enable a person using a character-based program, such as Lynx, to understand the material being presented in the graphical format. It also allows anyone who does not want to wait for graphics to load to have quick access to the information on the site.

b. Provide text transcriptions or descriptions for all audio output. This will enable people who are deaf or hard of hearing to have access to this information, as well as individuals who do not have sound cards.

c. Make any link text descriptive, but not verbose. For example, words like "this", "here", and "click" do not convey enough information about the nature of the link, especially to people who are blind. Link text should consist of substantive, descriptive words which can be quickly reviewed by the user. Conversely, link text which is too long bogs down efficient browsing.

d. Provide alternate mechanisms for on-line forms. Forms are not supported by all browsers. Therefore, it is important to provide the user with an opportunity to select alternate methods to access such forms.

e. All Web pages should be tested using multiple viewers. At a minimum, pages should be tested with the latest version of Lynx to ensure that they can be used with screen reader software.

#### Telecommunications Relay Services (TRS)

18. By using telecommunications relay services (TRS), it has now become easier for persons with hearing and speech disabilities to communicate by the telephone. TRS links TTY users with those who do not have a TTY and use standard telephones. With TRS, a TTY user communicates with another person with the help of a communications assistant who is able to talk on the telephone and then communicate by typing the message verbatim, to the TTY user. The communications assistant also reads the message typed by the TTY user, or the TTY user may speak for him or herself using voice carry over.

19. There are now TRS programs in every state. Although TRS is very valuable, it does have limitations. For example, relay calls take longer, since they always involve a third party, and typing words takes longer than speaking words.

#### Text Telephones (TTYs)

20. A TTY also provides direct two-way typed conversations. The cost of these devices begins at approximately \$200 and they can be operated by anyone who can type.

21. The following information is excerpted from the brochure "Using a TTY" which is available free of charge from the Access Board:

a. If the TTY line is also used for incoming voice calls, be sure the person who answers

the phone knows how to recognize and answer a TTY call. You will usually hear silence, a high-pitched, electronic beeping sound, or a pre-recorded voice message when it is a TTY call. If there is silence, assume it is a TTY call.

b. TTYs should be placed near a standard telephone so there is minimal delay in answering incoming TTY calls.

c. To initiate a TTY call, place the telephone headset in the acoustic cups of the TTY adapter. If the TTY unit is directly connected to the phone line, there is no need to put the telephone headset in the acoustic cups. Turn the TTY on. Make sure there is a dial tone by checking for a steady light on the TTY status indicator.

d. Dial the number and watch the status indicator light to see if the dialed number is ringing. The ring will make a long slow flash or two short flashes with a pause in between. If the line is busy, you will see short, continuous flashes on the indicator light. When the phone is answered, you will see an irregular light signal as the phone is picked up and placed in the cradle. If you are calling a combination TTY and voice number, tap the space bar several times to help the person on the other end identify this as a TTY call.

e. The person who answers the call is the first to type. Answer the phone as you would by voice, then type "GA".

f. "GA" means "I'm done, go ahead and type". "HD" means hold. "GA or SK" means "Is there anything more, I'm done". "SK" means stop keying. This is how you show that the conversation is ended and that you will hang up. It is polite to type good-bye, thank you for calling, or some other closing remark before you type "SK". Stay on the line until both parties type SKSK.

22. Because of the amount of time it takes to send and receive messages, it is important to remember that short words and sentences are desired by both parties. With some TTY calls it is often not possible to interrupt when the other person is typing. If you get a garbled message in all numbers or mixed numbers and letters, tap the space bar and see if the message clears up. If not, when the person stops typing, you should type, "Message garbled, please repeat." If the garbled messages continue, this may mean that one of the TTYs is not working properly, there is background noise causing interference, or that you may have a bad connection. In this case you should say something like, "Let's hang up and I'll call you back."

23. The typical TTY message will include many abbreviations and jargon. The message may also include misspelled words because, if the meaning is clear, many callers will not bother to correct spelling since it takes more time. Also, some TTY users communicate in American sign language, a language with its own grammar and syntax. English may be a second language. Extend the same patience

and courtesy to TTY callers as you do to all others.

Paragraph (b)

1. This paragraph requires manufacturers to supply a point of contact for obtaining information about accessibility features of the product and how to obtain documents in alternate formats. This could be the name of a specific person, a department or an office. Supplying a telephone number, and preferably a separate TTY number, is the most universal method. Web site and e-mail addresses are also desirable, but should not substitute for a telephone number since many more people have access to a telephone than have e-mail or Internet access. Of course, the means for requesting additional accessibility information must, itself, be accessible.

2. Automated voice response systems are not usable by deaf and hard of hearing persons. An approach to consider is to augment an automated voice response system with an automated TTY response system that also detects whether a caller is using voice or TTY.

3. The phone number should be prominently displayed in product literature. Ideally, it should be displayed on the outside of the package so that a potential buyer can obtain information about the accessibility before purchase. In addition, manufacturers should acquaint their distributors with this information so that they can assist customers with disabilities, such as a blind person unable to read the package information.

Paragraph (c)

1. This paragraph requires manufacturers to consider including information on accessibility in training a manufacturer provides to its staff. For example, if technical support staff are trained on how to provide good technical support, such a program should be expanded to include information on accessibility features of the manufacturer's products and peripheral devices that are compatible with them. Such staff should also have basic information on how to handle TTY and relay calls. Personnel who deal directly with the public, including market researchers, should be trained in basic disability "etiquette."

*Section 1193.35 Redundancy and Selectability  
[Reserved]*

1. Although this section is reserved, manufacturers of telecommunications equipment and customer premises equipment are encouraged to provide redundancy such that input and output functions are available in more than one mode.

2. Alternate input and output modes should be selectable by the user.

3. Products should incorporate multiple modes for input and output functions so the user is able to select the desired mode.

a. Since there is no single interface design that accommodates all disabilities, accessibility is likely to be accomplished through various product designs which emphasize interface flexibility to maximize user configurability and multiple, alternative and redundant modalities of input and output.

b. Selectability is especially important where an accessibility feature for one group of individuals with disabilities may conflict with an accessibility feature for another. This potential problem could be solved by allowing the user to switch one of the features on and off. For example, a conflict may arise between captioning (provided for persons who are deaf or hard of hearing) and a large font size (provided for persons with low vision). The resulting caption would either be so large that it obscures the screen or need to be scrolled or displayed in segments for a very short period of time.

c. It may not be readily achievable to provide all input and output functions in a single product or to permit all functions to be selectable. For example, switching requires control mechanisms which must be accessible and it may be more practical to have multiple modes running simultaneously. Whenever possible, it is preferable for the user to be able to turn on or off a particular mode.

4. Some experiments with smart cards are showing promise for enhancing accessibility. Instead of providing additional buttons or menu items to select appropriate input and output modes, basic user information can be stored on a smart card that triggers a custom configuration. For example, insertion of a particular card can cause a device to increase the font size on a display screen or activate speech output. Another might activate a feature to increase volume output, lengthen the response time between sequential operations, or allow two keys to be pressed sequentially instead of simultaneously. This technology, which depends on the issuance of a customized card to a particular individual, would allow redundancy and selectability without adding additional controls which would complicate the operation. As more and more functions are provided by software rather than hardware, this option may be more readily achievable.

5. The increasing use of "plug-ins" allow a product to be customized to the user's needs. Plug-ins function somewhat like peripheral devices to provide accessibility and there is no fundamental problem in using plug-ins to provide access, as long as the accessibility plug-ins are provided with the product. For example, at least one computer operating system comes packaged with accessibility enhancements which a user can install if wanted. In addition, modems are typically



sold with bundled software that provides the customer premises equipment functionality. A compatible screen reader program, for example, could be bundled with it. At least one software company has developed a generalized set of accessibility tools designed to be bundled with a variety of software products to provide access. As yet, such developments are not fully mature; most products are still installed by providing on-screen visual prompts, not accompanied by meaningful sounds.

*Section 1193.41 Input, Controls, and Mechanical Functions*

Paragraph (a)

Operable Without Vision

1. Individuals who are blind or have low vision cannot locate or identify controls, latches, or input slits by sight or operate controls that require sight. Products should be manufactured to be usable independently by these individuals. For example, individuals who cannot see must use either touch or sound to locate and identify controls. If a product uses a flat, smooth touch screen or touch membrane, the user without vision will not be able to locate the controls without auditory or tactile cues.

2. Once the controls have been located, the user must be able to identify the various functions of the controls. Having located and identified the controls, individuals must be able to operate them.

3. Below are some examples of ways to make products accessible to persons with visual disabilities:

a. If buttons are used on a product, make them discrete buttons which can be felt and located by touch. If a flat membrane is used for a keyboard, provide a raised edge around the control areas or buttons to make it possible to locate the keys by touch. Once an individual locates the different controls, he or she needs to identify what the keys are. If there is a standard number pad arrangement, putting a nib on the "5" key may be all that is necessary for identifying the numbers. On a QWERTY keyboard, putting a tactile nib on the "F" and "J" keys allows touch typists to easily locate their hands on the key.

b. Provide distinct shapes for keys to indicate their function or make it easy to tell them apart. Provide Braille labels for keys and controls for those who read Braille to determine the function and use of controls.

c. Provide large raised letters for short labels on large objects. Where it is not possible to use raised large letters, a voice mode selection could be incorporated that announces keys when pressed, but does not activate them. This would allow people to turn on the voice mode long enough to explore and locate the item they are interested in, then re-

lease the voice mode and press the control. If it is an adjustable control, voice confirmation of the status may also be important.

d. Provide tactile indication on a plug which is not a self-orienting plug. Wireless connections, which eliminate the need to orient or insert connectors, also solve the problem.

e. Avoid buttons that are activated when touched to allow an individual to explore the controls to find the desired button. If touch-activated controls cannot be avoided (for example, on a touch screen), provide an alternate mode where a confirm button is used to confirm selections (for example, items are read when touched, and activated when the confirm button is pressed). All actions should be reversible, or require confirmation before executing non-reversible actions.

f. Once controls have been located and users know what the functions are, they must be operable. Some types of controls, including mouse devices, track balls, dials without markings or stops, and push-button controls with only one state, where the position or setting is indicated only by a visual cue, will not be usable by persons who are blind or have low vision. Providing a rotational or linear stop and tactile or audio detents is a useful strategy. Another is to provide keyboard or push-button access to the functions. If the product has an audio system and microprocessor, use audio feedback of the setting. For simple products, tactile markings may be sufficient.

g. Controls may also be shaped so that they can easily be read by touch (e.g., a twist knob shaped like a pie wedge). For keys which do not have any physical travel, some type of audio or tactile feedback should be provided so that the individual knows when the key has been activated. A two-state key (on/off) should be physically different in each position (e.g., a toggle switch or a push-in/pop-out switch), so the person can tell what state the key is in by feeling it.

h. If an optional voice mode is provided for operating a product, a simple "query" mode can also be provided, which allows an individual to find out the function and state of a switch without actually activating it. In some cases, there may be design considerations which make the optimal mode for a sighted person inaccessible to someone without vision (e.g., use of a touch screen or mouse). In these cases, a primary strategy may be to provide a closely linked parallel method for efficiently achieving the same results (e.g., keyboard access) if there is a keyboard, or "SpeedList" access for touch screens.

## Paragraph (b)

## Operable With Low Vision and Limited or No Hearing

1. Individuals with low vision often also have hearing disabilities, especially older individuals. These persons cannot rely solely on audio access modes commonly used by people who are blind. Tactile strategies are still quite useful, although many older persons may not be familiar with Braille. The objective, therefore, is to maximize the number of people who can use their residual vision, combined with tactile senses, to operate a product.

2. Strategies for addressing this provision may include the following: a. Make the information on the product easier to see. Use high-contrast print symbols and visual indicators, minimize glare on the display and control surfaces, provide adequate lighting, position controls near the items they control to make them easy to find, and use Arabic instead of Roman numerals.

b. The type-face and type-spacing used can greatly affect legibility. The spacing between letters should be approximately 1/16 the height of uppercase letters and the spacing should be uniform from one label to the next. Also, symbols can sometimes be used which are much more legible and understandable than fine print.

c. Where the display is dynamic, provide a means for the user to enlarge the display and to “freeze” it. In addition to making it easier to see, there are strategies which can be used to reduce the need to see things clearly in order to operate them.

d. A judicious use of color-coding, always redundant with other cues, is extremely helpful to persons with low vision. These cues should follow standard conventions, and can be used to reduce the need to read labels (or read labels more than the first time). In addition, all of the tactile strategies discussed under section 1193.41 (a) can also be used here.

## Paragraph (c)

## Operable With Little or No Color Perception

1. Many people are unable to distinguish between certain color combinations. Others are unable to see color at all.

2. Strategies for addressing this provision include:

a. Eliminate the need for a person see color to operate the product. This does not eliminate the use of color completely but rather requires that any information essential to the operation of a product also be conveyed in some other fashion.

b. Avoid color pairs such as red/green and blue/yellow, that are indistinguishable by people with limited color perception.

c. Provide colors with different hues and intensity so that colored objects can be dis-

tinguished even on a black and white screen by their different appearance. Depending upon the product, the manufacturer may also be able to allow users to adjust colors to match their preferences and visual abilities.

d. Avoid colors with a low luminance.

## Paragraph (d)

## Operable Without Hearing

1. Individuals who are deaf or hard of hearing cannot locate or identify controls that require hearing. Products that provide only audio prompts cannot be used by individuals who are deaf or hard of hearing. For example, a voice-based interactive product that can be controlled only by listening to menu items and then pressing buttons is not accessible. By addressing the output issues under section 1193.43(d) many accessibility problems that affect input under this section can be solved.

2. Some strategies include:

a. Text versions of audio prompts could be provided which are synchronized with the audio so that the timing is the same.

b. If prompts are provided visually and no speech or vocalization is required, most problems associated with locating, identifying, and operating controls without hearing will be solved.

## Paragraph (e)

## Operable With Limited Manual Dexterity

1. Individuals may have difficulty manipulating controls on products for any number of reasons. Though these disabilities may vary widely, these persons have difficulty grasping, pinching, or twisting objects and often have difficulty with finer motor coordination. Some persons may use a headstick, mouthstick, or artificial limb.

2. Below are some strategies which will assist in designing products which will meet the needs of these persons:

a. Provide larger buttons and controls, or buttons which are more widely spaced, to reduce the likelihood that a user will accidentally activate an adjacent control.

b. Provide guard bars between the buttons or near the buttons so that accidental movements would hit the guard bars rather than accidentally bumping switches.

c. Provide an optional mode where buttons must be depressed for a longer period of time (e.g., SlowKeys) before they would accept input to help separate between inadvertent motions or bumps and desired activation.

d. Where two buttons must be depressed simultaneously, provide an option to allow them to be activated sequentially (e.g., StickiKeys).

e. Avoid buttons which are activated merely by touch, such as capacitance switches. Where that is difficult to do (e.g., with touchscreens), provide a “confirm” button

which an individual can use to confirm that the item touched is the desired one. Also, make all actions reversible, or request confirmation before initiating non-reversible actions.

f. Avoid latches, controls, or key combinations which require simultaneous activation of two or more buttons, or latches. Also, avoid very small controls or controls which require rotation of the wrist or pinching and twisting. Where this is not possible, provide alternate means for achieving the same functions.

g. Controls which have non-slip surfaces and those that can be operated with the side of the hand, elbow or pencil can be used to minimize physical activity required. In some cases, rotary controls can be used if they can be operated without grasping and twisting (e.g., a thin pie slice shape control or an edge control). Providing a concave top on buttons makes them easier to use.

h. Make it easier to insert cards or connectors by providing a bevel around the slot or connector, or use cards or connectors which can be inserted in any orientation or which self-center or self-align. Placing the slot or connector on the front and near a ledge or open space allows individuals to brace their hands or arms to make use of the slot or connector easier.

i. For some designs, controls which pose problems for individuals with disabilities may be the most efficient, logical or effective mechanism for a majority of users. In these cases, provide alternate strategies for achieving the same functions, but which do not require fine manipulation. Speech input or voice recognition could be provided as an alternate input, although it should not be the only input technique.

#### Paragraph (f)

##### Operable With Limited Reach and Strength

1. Some individuals may have difficulty operating systems which require reach or strength. The most straight-forward solution to this problem is to place the controls where they can be easily reached with minimal changes to body position. Many products also have controls located on different parts of the product.

2. When this is the case, the following strategies may be used:

a. Allow the functions to be controlled from the keyboard, which is located directly in front of the user.

b. Allow voice recognition to be used as an option. This provides input flexibility, but should never be the only means for achieving a function.

c. Provide a remote control option that moves all of the controls for the product together on a unit that can be positioned optimally for the individual. This allows the individual to operate the product without hav-

ing to move to it. If this strategy is used, a standard communication format would be important to allow the use of alternate remote controls for those who cannot use the standard remote control.

d. Reduce the force needed to operate controls or latches and avoid the need for sustained pressure or activity (e.g., use guards rather than increased strength requirements to avoid accidental activation of crucial switches).

e. Provide arm or wrist rests or supports, create short cuts that reduce the number of actions needed, or completely eliminate the need to operate controls wherever possible by having automatic adjustments.

f. Section 4.34.3 of the Americans with Disabilities Act Accessibility Guidelines (ADAAG) also contains specific information concerning reach ranges. ADAAG gives specific guidance concerning access to the built environment. Section 4.34.3 indicates the reach ranges for a front or parallel approach to equipment for individuals using a wheelchair. This information may prove useful for those telecommunications manufacturers whose equipment is stationary, such as an information kiosk.

#### Paragraph (g)

##### Operable Without Time-Dependent Controls

1. Many persons find it very difficult to operate time-dependent controls.

2. Some strategies which address this problem include:

a. Avoid any timed-out situations or provide instances where the user must respond to a question or moving display in a set amount of time or at a specific time (e.g., a rotating display).

b. Where timed responses are required or appropriate, allow the user to adjust them or set the amount of time allotted to complete a given task. Warn users that time is running out and allow them to secure extended time.

c. If the standard mode of operation would be awkward or inefficient, then provide an alternate mode of operation that offers the same functions.

#### Paragraph (h)

##### Operable Without Speech

1. Many individuals cannot speak or speak clearly. Products which require speech in order to operate them should also provide an alternate way to achieve the same function.

2. Some strategies to achieve this include:

a. Provide an alternate mechanism for achieving all of the functions which are controlled by speech. If a product includes speech identification or verification, provide an alternate mechanism for this function as well.

b. Include individuals who are deaf or who have speech disabilities in the subject populations that are used to develop voice recognition algorithms, so that the algorithms will better accommodate a wider range of speech patterns.

Paragraph (i)

Operable With Limited Cognitive Skills

1. Many individuals have reduced cognitive abilities, including reduced memory, sequence tracking, and reading skills. This does not necessarily prevent these persons from using a telecommunications product or feature.

2. The following strategies are extensions of techniques for making products easier for everyone to learn and use:

a. Use standard colors and shapes and group similar functions together. On products which have some controls that are used by everyone and other controls which would only be used by advanced users, it is generally good practice to separate the two, putting the more advanced features behind a door or under a separate menu item.

b. Products which read the contents of the display aloud, or controls which announce their settings, are easier for individuals who have difficulty reading.

c. Design products that are self-adjusting to eliminate additional controls which must be learned, and reduce the visual clutter.

d. On products which have sign-in procedures, allow user settings to be associated with them when they sign in or insert their identification card. The system can then autoconfigure to them. Some new “smart cards” are being designed with user preferences encoded on the card.

e. Where a complex series of steps is required, provide cuing to help lead the person through the process. It is also helpful to provide an “undo” or back up function, so that any mistakes can be easily corrected. Most people will find this function helpful.

f. Where functions are not reversible, request some type of confirmation from the user before proceeding. On labels and instructions, it is helpful to use short and simple phrases or sentences. Avoid abbreviations wherever possible. Eliminate the need to respond within a certain time or to read text within a certain time.

*Section 1193.43 Output, Displays, and Control Functions*

Paragraph (a)

Availability of Visual Information

1. Just as persons with visual or cognitive disabilities need to be able to operate the input, controls, and mechanical functions of a product, they must also have access to the output functions.

2. The following are strategies for addressing this provision:

a. Provide speech output of all displayed text and labels. For information which is presented in non-text form (e.g., a picture or graphic), provide a verbal description unless the graphic is just decorative. When speech output is provided, allow for the spoken message to be repeated if the message is very long. Also, if the information being provided is personal in nature, it is recommended that headphones be provided in order to assure privacy. A message for stepping through menus is also helpful.

b. Providing Braille labels for controls is an extremely effective mechanism for those individuals who read Braille.

c. Large raised print can also be used but is generally restricted to rather large objects due to the size of the letters.

Paragraph (b)

Availability of Visual Information for Low Vision Users

1. Individuals with low vision often also have hearing disabilities, especially older individuals. These persons cannot rely solely on audio access modes commonly used by people who are blind. Tactile strategies are still quite useful. Many people who have low vision can use their vision to access visually presented information on a product.

2. Strategies for meeting this provision involve:

a. Provide larger, higher contrast text and graphics. Individuals with 20/200 vision can see lettering if they get close to it, unless it is very small or has very poor contrast. Although 14 or 18 point type is recommended for visual displays, it is usually not possible to put this size text on small products.

b. Make the lettering as large and high contrast as possible to maximize the number of people who can use the product.

c. On displays where the font size can be varied, allow the user to increase the font size, even if it means that the user must pan or move in order to see the full display.

Paragraph (c)

Access to Moving Text

1. Moving text can be an access problem because individuals with low vision, or other disabilities may find it difficult or impossible to track moving text with their eyes.

2. Strategies to address this requirement may include the following:

a. Provide a mechanism for freezing the text. Thus, persons could read the stationary text and obtain the same information.

b. Provide scrolling to display one full line at a time, with a pause before the next line replaces it.

c. Provide the same information in another type of display which does not move. The

right-to-left scrolling text on a TTY does not usually present a problem because it can be controlled by asking the sender to type slower or pause at specified intervals.

Paragraph (d)

Availability of Auditory Information

1. Individuals who have hearing disabilities are unable to receive auditory output, or mechanical and other sounds that are emitted by a product. These sounds are often important for the safe or effective operation of the product. Therefore, information which is presented auditorially should be available to all users.

2. Some strategies to achieve this include the following:

a. Provide a visual or tactile signal that will attract the person's attention and alert the user to a call, page, or other message, or to warn the user of significant mechanical difficulties in the product.

b. In portable products, a tactile signal such as vibration is often more effective than a visual signal because a visual signal may be missed. An auxiliary vibrating signaler might be effective if it is not readily achievable or effective to build vibration into a portable product.

c. For stationary products, a prominent visual indicator in the field of vision (e.g., a screen flash for a computer, or a flashing light for a telephone) is effective. To inform the user of the status of a process (e.g., line status on a telephone call, power on, saving to disk, or disconnected), text messages may be used. It is also desirable to have an image or light that is activated whenever acoustic energy is present on a telephone line.

d. Speech messages should be portrayed simultaneously in text form and displayed where easily seen by the user. Such captions should usually be verbatim and displayed long enough to be easily read. If the product provides speech messages and the user must respond to those messages (e.g., interactive voice response and voice mail), a TTY accessible method of accessing the product could be provided.

e. TTY to TTY long distance and message unit calls from pay telephones are often not possible because an operator says how much money must be deposited. Technology exists to have this information displayed on the telephone and a test installation is currently operating at the Butler plaza on the Pennsylvania Turnpike. In addition, if the product provides interactive communication using speech and video, it would be helpful to provide a method and channel for allowing non-speech communication (e.g., text conversation) in parallel with the video.

f. Certain operations of products make sounds that give status information, although these sounds are not programmed signals. Examples include the whir of an op-

erating disk drive and the click of a key being pushed. Where sounds of this type provide information important for operating the product, such as a "beep" when a key is activated, provide a light or other visual confirmation of activation.

Paragraph (e)

Availability of Auditory Information for People Who Are Hard of Hearing

1. People who are hard of hearing but not deaf can often use their hearing to access auditory information on a product.

2. Strategies for addressing this requirement may include the following:

a. Improve the signal to noise ratio by making the volume adjustable, between 18-25 dB, increasing the maximum undistorted volume, and minimizing background noise by such methods as better coupling between the signal source and the user.

b. Alerting tones are most likely to be heard if they involve multiple tones, separated in frequency, which contrast with the environment.

c. Occasionally, varying tones may be preferred for attracting attention. If speech is used, it is best to test its intelligibility with individuals who are hard of hearing to maximize its clarity and ease of understanding. Provide the ability for the user to have any messages repeated or to repeat the message if no response is received from the user.

d. For essential auditory information, the information might be repeated and an acknowledgment from the user requested.

e. The intelligibility of the output can also be maximized by the location of the speakers and by keeping the speakers away from noise sources. However, visual displays are often more desirable than loud prompts or alerts, because the latter reduce privacy and can annoy others unless the amplified signal is isolated by means of a headphone, induction coupling, direct plug-in to a hearing aid, or other methods.

f. The use of a telephone handset or earcup which can be held up to the ear can improve intelligibility without disturbing others in the area. If a handset or earcup is used, making it compatible with a hearing aid allows users to directly couple the auditory signal to their hearing aids. If the microphone in the handset is not being used, turning it off will also reduce the amount of background noise which the person hears in the earpiece. Providing a headphone jack also allows individuals to plug in headphones, induction loops, or amplifiers which they may use to hear better.

Paragraph (f)

Prevention of Visually-Induced Seizures

1. Individuals with photo-sensitive epilepsy can have a seizure triggered by displays

which flicker or flash, particularly if the flash has a high intensity and within certain frequency ranges.

2. Strategies to address this requirement involve reducing or eliminating screen flicker or image flashing to the extent possible. In particular, the rates of 2 Hz or lower or 70 Hz or higher are recommended. This recommendation reflects current research data on people with photosensitive epilepsy which indicates that the peak sensitivity for these individuals is 20 Hz and that the sensitivity then drops off in both directions.

3. The chance of triggering seizures can also be reduced by avoiding very bright flashes which occupy a large part of the visual field (particularly in the center of the visual field) in order to minimize the impact on the visual cortex.

#### Paragraph (g)

##### Availability of Audio Cutoff

1. Individuals using the audio access mode, as well as those using a product with the volume turned up, need a way to limit the range of audio broadcast.

2. If an audio headphone jack is provided, a cut-off switch can be included in the jack so that insertion of the jack would cut off the speaker. If a telephone-like handset is used, the external speakers can be turned off when the handset is removed from the cradle.

#### Paragraph (h)

##### Non-Interference With Hearing Technologies

1. Individuals who are hard of hearing use hearing aids and other assistive listening devices but these devices cannot be used if a telecommunications product introduces noise into the listening aids because of stray electromagnetic interference.

2. Strategies for reducing this interference (as well as improving hearing aid immunity) are being researched. The most desirable strategy is to avoid the root causes of interference when a product is initially designed. If the root sources of interference cannot be removed, then shielding, placement of components to avoid hearing aid interference, and field-canceling techniques may be effective. Standards are being developed to limit interference to acceptable levels, but complete elimination for some technologies may not yet be practical.

3. In April 1996, the American National Standards Institute (ANSI) established a task group (ANSI C63) under its subcommittee on medical devices to develop standards to measure hearing aid compatibility and accessibility to digital wireless telecommunications. The C63.19 task group is continuing to develop its standard, C63.19-199X, American National Standard for Methods of Measurement for Hearing Aid Compatibility with Wireless Communications De-

vices. When the standard is completed, the Board intends to reference it in this appendix.

#### Paragraph (i)

##### Hearing Aid Coupling

1. Many individuals who are hard of hearing use hearing aids with a T-coil (or telecoil) feature to allow them to listen to audio output of products without picking up background noise and to avoid problems with feedback, signal attenuation or degradation.

2. The Hearing Aid Compatibility (HAC) Act defines a telephone as hearing aid compatible if it provides internal means for effective use with hearing aids and meets established technical standards for hearing aid compatibility.

3. The technical standards for HAC telephones are specified in ANSI/EIA-504-1989, "Magnetic Field Intensity Criteria for Telephone Compatibility with Hearing Aids," ANSI/TIA/EIA-504-1-1994, "An Addendum to EIA-504," which adds the HAC requirements, and the FCC regulations at 47 CFR 68.317 (a).

4. A good strategy for addressing this requirement for any product held up to the ear would be to meet these same technical requirements. If not readily achievable to provide built-in telecoil compatibility, other means of providing the electro-magnetic signal is the next strategy to be considered.

#### SUBPART D "REQUIREMENTS FOR COMPATIBILITY WITH PERIPHERAL DEVICES AND SPECIALIZED CUSTOMER PREMISES EQUIPMENT"

##### Section 1193.51 Compatibility

#### Paragraph (a)

##### External Electronic Access to All Information and Control Mechanisms

1. Some individuals with severe or multiple disabilities are unable to use the built-in displays and control mechanisms on a product.

2. The two most common forms of manipulation-free connections are an infrared connection or a radio frequency connection point. Currently, the Infrared Data Association (IrDA) infrared connection point is the most universally used approach.

3. The Infrared Data Association together with dominant market players in the cellular and paging industries, Ericsson, Matsushita/Panasonic, Motorola, NEC, Nokia, NTT DoCoMo, Puma, and TU-KA Phone Kansai, announced on April 25, 1997 a proposed set of standards that will empower wireless communication devices, such as cellular phones, pagers and personal computers to transfer useful information over short distances using IrDA infrared data communication ports. Because the proposed standard is designed to be scalable, it is easy-to-adopt by a wide range of wireless devices from pagers

to more enhanced communications tools such as smart phones. (See <http://www.irda.org>).

4. Adding an infrared connector to the serial port of a peripheral device or specialized customer premises equipment will make these products more compatible with each other and with customer premises equipment.

5. An infrared link can provide a mechanism for providing access to smaller, more advanced telecommunication devices and provide a safety net for products which are unable to incorporate other technologies. There is a joint international effort to develop a Universal Remote Console Communication (URCC) protocol which would achieve this functionality. (See <http://trace.wisc.edu/world/urc>).

#### Paragraph (b)

##### Connection Point for External Audio Processing Devices

1. Individuals using audio peripheral devices such as amplifiers, telecoil adapters, or direct-connection into a hearing aid need a standard, noise free way to tap into the audio generated by a product.

2. Individuals who cannot hear well can often use products if they can isolate and enhance the audio output. For example, they could plug in a headphone which makes the audio louder and helps shut out background noise; they might feed the signal through an amplifier to make it louder, or through filters or frequency shifters to make it better fit their audio profile. If they are wearing a hearing aid, they may directly connect their hearing aid to the audio signal or plug in a small audio loop which allows them to couple the audio signal through their hearing aid's built-in T-coil.

3. Devices which can process the information and provide visual and/or tactile output are also possible. The most common strategy for achieving this requirement is the use of a standard 9 mm miniature plug-in jack, common to virtually every personal tape player or radio. For small products, a sub-miniature phone jack could be used.

#### Paragraph (c)

##### Compatibility of Controls With Prosthetics

1. Individuals who have artificial hands or use headsticks or mouthsticks to operate products have difficulty with capacitive or heat-operated controls which require contact with a person's body rather than a tool. Individuals who wear prosthetics are unable to operate some types of products because they either require motions that cannot easily be made with a prosthetic hand, or because products are designed which require touch of the human skin to operate them (e.g., capacitive touchscreen kiosks), making it im-

possible for individuals with artificial arms or hands to operate, except perhaps with their nose or chin. Some individuals who do not have the use of their arms use either a headstick or a mouthstick to operate products. Controls and mechanisms which require a grasping and twisting motion should be avoided.

#### Paragraph (d)

##### TTY Connectability

1. Acoustic coupling is subject to interference from ambient noise, as many handsets do not provide an adequate seal with TTYs. Therefore, alternate (non-acoustic) connections are needed. Control of the microphone is needed for situations such as pay-phone usage, where ambient noise picked up by the mouthpiece often garbles the signal. For the use of voice carry-over, where the person can speak but not hear, the user needs to be able to turn the microphone on to speak and off to allow them to receive the TTY text replies.

2. A TTY can be connected to and used with any telecommunications product supporting speech communication without requiring purchase of a special adapter, and the user is able to intermix speech and clear TTY communication. The most common approach today is to provide an RJ-11 jack. On very small products, where there may not be room for this large jack, a miniature or sub-miniature phone-jack wired as a "headset" jack (with both speaker and microphone connections) could be used as an alternate approach. In either case, a mechanism for turning the phone mouthpiece (microphone) on and off would reduce garbling in noisy environments, while allowing the user to speak into the microphone when desired (to conduct conversations with mixed voice and TTY). For equipment that combines voice communications, displays, keyboards and data communication functions, it is desirable to build in direct TTY capability.

#### Paragraph (e)

##### TTY Signal Compatibility

1. Some telecommunications systems compress the audio signal in such a manner that standard signals used by a TTY is distorted or attenuated preventing successful TTY communication over the system. A TTY can be used with any product providing voice communication function.

2. The de facto standard of domestic TTYs is Baudot which has been defined in ITU-T Recommendation V.18. Although the V.18 standard has been adopted, products are not yet available which meet its requirements.

3. This provision can be addressed by ensuring that the tones used can travel

through the phones compression circuits undistorted. It is even more desirable to provide undistorted connectivity to the telephone line in the frequency range of 390 Hz to 2300 Hz (ITU-T Recommendation V.18), as this range covers all of the TTY protocols known throughout the world. Although it may not be achievable with current technology, an alternate strategy might be to recognize the tones, transmit them as codes, and resynthesize them at the other end. In addition, it should be possible for individuals using TTYs to conduct conversations with mixed voice and TTY, and to control all aspects of the product and receive any messages generated by the product.

## PART 1194—ELECTRONIC AND INFORMATION TECHNOLOGY ACCESSIBILITY STANDARDS

### Subpart A—General

Sec.

- 1194.1 Purpose.
- 1194.2 Application.
- 1194.3 General exceptions.
- 1194.4 Definitions.
- 1194.5 Equivalent facilitation.

### Subpart B—Technical Standards

- 1194.21 Software applications and operating systems.
- 1194.22 Web-based intranet and internet information and applications.
- 1194.23 Telecommunications products.
- 1194.24 Video and multimedia products.
- 1194.25 Self contained, closed products.
- 1194.26 Desktop and portable computers.

### Subpart C—Functional Performance Criteria

- 1194.31 Functional performance criteria.

### Subpart D—Information, Documentation, and Support

- 1194.41 Information, documentation, and support.

FIGURES TO PART 1194

AUTHORITY: 29 U.S.C. 794d.

SOURCE: 65 FR 80523, Dec. 21, 2000, unless otherwise noted.

### Subpart A—General

#### § 1194.1 Purpose.

The purpose of this part is to implement section 508 of the Rehabilitation Act of 1973, as amended (29 U.S.C. 794d). Section 508 requires that when Federal agencies develop, procure, maintain, or

use electronic and information technology, Federal employees with disabilities have access to and use of information and data that is comparable to the access and use by Federal employees who are not individuals with disabilities, unless an undue burden would be imposed on the agency. Section 508 also requires that individuals with disabilities, who are members of the public seeking information or services from a Federal agency, have access to and use of information and data that is comparable to that provided to the public who are not individuals with disabilities, unless an undue burden would be imposed on the agency.

#### § 1194.2 Application.

(a) Products covered by this part shall comply with all applicable provisions of this part. When developing, procuring, maintaining, or using electronic and information technology, each agency shall ensure that the products comply with the applicable provisions of this part, unless an undue burden would be imposed on the agency.

(1) When compliance with the provisions of this part imposes an undue burden, agencies shall provide individuals with disabilities with the information and data involved by an alternative means of access that allows the individual to use the information and data.

(2) When procuring a product, if an agency determines that compliance with any provision of this part imposes an undue burden, the documentation by the agency supporting the procurement shall explain why, and to what extent, compliance with each such provision creates an undue burden.

(b) When procuring a product, each agency shall procure products which comply with the provisions in this part when such products are available in the commercial marketplace or when such products are developed in response to a Government solicitation. Agencies cannot claim a product as a whole is not commercially available because no product in the marketplace meets all the standards. If products are commercially available that meet some but not all of the standards, the agency must procure the product that best meets the standards.



## Architectural and Transp. Barriers Compliance Board

## § 1194.4

(c) Except as provided by §1194.3(b), this part applies to electronic and information technology developed, procured, maintained, or used by agencies directly or used by a contractor under a contract with an agency which requires the use of such product, or requires the use, to a significant extent, of such product in the performance of a service or the furnishing of a product.

### § 1194.3 General exceptions.

(a) This part does not apply to any electronic and information technology operated by agencies, the function, operation, or use of which involves intelligence activities, cryptologic activities related to national security, command and control of military forces, equipment that is an integral part of a weapon or weapons system, or systems which are critical to the direct fulfillment of military or intelligence missions. Systems which are critical to the direct fulfillment of military or intelligence missions do not include a system that is to be used for routine administrative and business applications (including payroll, finance, logistics, and personnel management applications).

(b) This part does not apply to electronic and information technology that is acquired by a contractor incidental to a contract.

(c) Except as required to comply with the provisions in this part, this part does not require the installation of specific accessibility-related software or the attachment of an assistive technology device at a workstation of a Federal employee who is not an individual with a disability.

(d) When agencies provide access to the public to information or data through electronic and information technology, agencies are not required to make products owned by the agency available for access and use by individuals with disabilities at a location other than that where the electronic and information technology is provided to the public, or to purchase products for access and use by individuals with disabilities at a location other than that where the electronic and information technology is provided to the public.

(e) This part shall not be construed to require a fundamental alteration in the nature of a product or its components.

(f) Products located in spaces frequented only by service personnel for maintenance, repair, or occasional monitoring of equipment are not required to comply with this part.

### § 1194.4 Definitions.

The following definitions apply to this part:

*Agency.* Any Federal department or agency, including the United States Postal Service.

*Alternate formats.* Alternate formats usable by people with disabilities may include, but are not limited to, Braille, ASCII text, large print, recorded audio, and electronic formats that comply with this part.

*Alternate methods.* Different means of providing information, including product documentation, to people with disabilities. Alternate methods may include, but are not limited to, voice, fax, relay service, TTY, Internet posting, captioning, text-to-speech synthesis, and audio description.

*Assistive technology.* Any item, piece of equipment, or system, whether acquired commercially, modified, or customized, that is commonly used to increase, maintain, or improve functional capabilities of individuals with disabilities.

*Electronic and information technology.* Includes information technology and any equipment or interconnected system or subsystem of equipment, that is used in the creation, conversion, or duplication of data or information. The term electronic and information technology includes, but is not limited to, telecommunications products (such as telephones), information kiosks and transaction machines, World Wide Web sites, multimedia, and office equipment such as copiers and fax machines. The term does not include any equipment that contains embedded information technology that is used as an integral part of the product, but the principal function of which is not the acquisition, storage, manipulation, management, movement, control, display, switching, interchange, transmission, or reception of data or information.

## § 1194.5

For example, HVAC (heating, ventilation, and air conditioning) equipment such as thermostats or temperature control devices, and medical equipment where information technology is integral to its operation, are not information technology.

*Information technology.* Any equipment or interconnected system or subsystem of equipment, that is used in the automatic acquisition, storage, manipulation, management, movement, control, display, switching, interchange, transmission, or reception of data or information. The term information technology includes computers, ancillary equipment, software, firmware and similar procedures, services (including support services), and related resources.

*Operable controls.* A component of a product that requires physical contact for normal operation. Operable controls include, but are not limited to, mechanically operated controls, input and output trays, card slots, keyboards, or keypads.

*Product.* Electronic and information technology.

*Self Contained, Closed Products.* Products that generally have embedded software and are commonly designed in such a fashion that a user cannot easily attach or install assistive technology. These products include, but are not limited to, information kiosks and information transaction machines, copiers, printers, calculators, fax machines, and other similar types of products.

*Telecommunications.* The transmission, between or among points specified by the user, of information of the user's choosing, without change in the form or content of the information as sent and received.

*TTY.* An abbreviation for teletypewriter. Machinery or equipment that employs interactive text based communications through the transmission of coded signals across the telephone network. TTYS may include, for example, devices known as TDDs (telecommunication display devices or telecommunication devices for deaf persons) or computers with special modems. TTYS are also called text telephones.

*Undue burden.* Undue burden means significant difficulty or expense. In de-

## 36 CFR Ch. XI (7-1-03 Edition)

termining whether an action would result in an undue burden, an agency shall consider all agency resources available to the program or component for which the product is being developed, procured, maintained, or used.

### § 1194.5 Equivalent facilitation.

Nothing in this part is intended to prevent the use of designs or technologies as alternatives to those prescribed in this part provided they result in substantially equivalent or greater access to and use of a product for people with disabilities.

## Subpart B—Technical Standards

### § 1194.21 Software applications and operating systems.

(a) When software is designed to run on a system that has a keyboard, product functions shall be executable from a keyboard where the function itself or the result of performing a function can be discerned textually.

(b) Applications shall not disrupt or disable activated features of other products that are identified as accessibility features, where those features are developed and documented according to industry standards. Applications also shall not disrupt or disable activated features of any operating system that are identified as accessibility features where the application programming interface for those accessibility features has been documented by the manufacturer of the operating system and is available to the product developer.

(c) A well-defined on-screen indication of the current focus shall be provided that moves among interactive interface elements as the input focus changes. The focus shall be programmatically exposed so that assistive technology can track focus and focus changes.

(d) Sufficient information about a user interface element including the identity, operation and state of the element shall be available to assistive technology. When an image represents a program element, the information conveyed by the image must also be available in text.

(e) When bitmap images are used to identify controls, status indicators, or

other programmatic elements, the meaning assigned to those images shall be consistent throughout an application's performance.

(f) Textual information shall be provided through operating system functions for displaying text. The minimum information that shall be made available is text content, text input caret location, and text attributes.

(g) Applications shall not override user selected contrast and color selections and other individual display attributes.

(h) When animation is displayed, the information shall be displayable in at least one non-animated presentation mode at the option of the user.

(i) Color coding shall not be used as the only means of conveying information, indicating an action, prompting a response, or distinguishing a visual element.

(j) When a product permits a user to adjust color and contrast settings, a variety of color selections capable of producing a range of contrast levels shall be provided.

(k) Software shall not use flashing or blinking text, objects, or other elements having a flash or blink frequency greater than 2 Hz and lower than 55 Hz.

(l) When electronic forms are used, the form shall allow people using assistive technology to access the information, field elements, and functionality required for completion and submission of the form, including all directions and cues.

**§ 1194.22 Web-based intranet and internet information and applications.**

(a) A text equivalent for every non-text element shall be provided (*e.g.*, via "alt", "longdesc", or in element content).

(b) Equivalent alternatives for any multimedia presentation shall be synchronized with the presentation.

(c) Web pages shall be designed so that all information conveyed with color is also available without color, for example from context or markup.

(d) Documents shall be organized so they are readable without requiring an associated style sheet.

(e) Redundant text links shall be provided for each active region of a server-side image map.

(f) Client-side image maps shall be provided instead of server-side image maps except where the regions cannot be defined with an available geometric shape.

(g) Row and column headers shall be identified for data tables.

(h) Markup shall be used to associate data cells and header cells for data tables that have two or more logical levels of row or column headers.

(i) Frames shall be titled with text that facilitates frame identification and navigation.

(j) Pages shall be designed to avoid causing the screen to flicker with a frequency greater than 2 Hz and lower than 55 Hz.

(k) A text-only page, with equivalent information or functionality, shall be provided to make a web site comply with the provisions of this part, when compliance cannot be accomplished in any other way. The content of the text-only page shall be updated whenever the primary page changes.

(l) When pages utilize scripting languages to display content, or to create interface elements, the information provided by the script shall be identified with functional text that can be read by assistive technology.

(m) When a web page requires that an applet, plug-in or other application be present on the client system to interpret page content, the page must provide a link to a plug-in or applet that complies with § 1194.21(a) through (l).

(n) When electronic forms are designed to be completed on-line, the form shall allow people using assistive technology to access the information, field elements, and functionality required for completion and submission of the form, including all directions and cues.

(o) A method shall be provided that permits users to skip repetitive navigation links.

(p) When a timed response is required, the user shall be alerted and given sufficient time to indicate more time is required.

NOTE TO § 1194.22: 1. The Board interprets paragraphs (a) through (k) of this section as consistent with the following priority 1

**§ 1194.23**

Checkpoints of the Web Content Accessibility Guidelines 1.0 (WCAG 1.0) (May 5, 1999) published by the Web Accessibility Initiative of the World Wide Web Consortium:

Section 1194.22 paragraph	WCAG 1.0 checkpoint
(a) .....	1.1
(b) .....	1.4
(c) .....	2.1
(d) .....	6.1
(e) .....	1.2
(f) .....	9.1
(g) .....	5.1
(h) .....	5.2
(i) .....	12.1
(j) .....	7.1
(k) .....	11.4

2. Paragraphs (l), (m), (n), (o), and (p) of this section are different from WCAG 1.0. Web pages that conform to WCAG 1.0, level A (*i.e.*, all priority 1 checkpoints) must also meet paragraphs (l), (m), (n), (o), and (p) of this section to comply with this section. WCAG 1.0 is available at <http://www.w3.org/TR/1999/WAI-WEBCONTENT-19990505>.

**§ 1194.23 Telecommunications products.**

(a) Telecommunications products or systems which provide a function allowing voice communication and which do not themselves provide a TTY functionality shall provide a standard non-acoustic connection point for TTYs. Microphones shall be capable of being turned on and off to allow the user to intermix speech with TTY use.

(b) Telecommunications products which include voice communication functionality shall support all commonly used cross-manufacturer non-proprietary standard TTY signal protocols.

(c) Voice mail, auto-attendant, and interactive voice response telecommunications systems shall be usable by TTY users with their TTYs.

(d) Voice mail, messaging, auto-attendant, and interactive voice response telecommunications systems that require a response from a user within a time interval, shall give an alert when the time interval is about to run out, and shall provide sufficient time for the user to indicate more time is required.

(e) Where provided, caller identification and similar telecommunications functions shall also be available for users of TTYs, and for users who cannot see displays.

(f) For transmitted voice signals, telecommunications products shall provide a gain adjustable up to a minimum of 20 dB. For incremental volume control, at least one intermediate step of 12 dB of gain shall be provided.

(g) If the telecommunications product allows a user to adjust the receive volume, a function shall be provided to automatically reset the volume to the default level after every use.

(h) Where a telecommunications product delivers output by an audio transducer which is normally held up to the ear, a means for effective magnetic wireless coupling to hearing technologies shall be provided.

(i) Interference to hearing technologies (including hearing aids, cochlear implants, and assistive listening devices) shall be reduced to the lowest possible level that allows a user of hearing technologies to utilize the telecommunications product.

(j) Products that transmit or conduct information or communication, shall pass through cross-manufacturer, non-proprietary, industry-standard codes, translation protocols, formats or other information necessary to provide the information or communication in a usable format. Technologies which use encoding, signal compression, format transformation, or similar techniques shall not remove information needed for access or shall restore it upon delivery.

(k) Products which have mechanically operated controls or keys, shall comply with the following:

(1) Controls and keys shall be tactilely discernible without activating the controls or keys.

(2) Controls and keys shall be operable with one hand and shall not require tight grasping, pinching, or twisting of the wrist. The force required to activate controls and keys shall be 5 lbs. (22.2 N) maximum.

(3) If key repeat is supported, the delay before repeat shall be adjustable to at least 2 seconds. Key repeat rate shall be adjustable to 2 seconds per character.

(4) The status of all locking or toggle controls or keys shall be visually discernible, and discernible either through touch or sound.

**§ 1194.24 Video and multimedia products.**

(a) All analog television displays 13 inches and larger, and computer equipment that includes analog television receiver or display circuitry, shall be equipped with caption decoder circuitry which appropriately receives, decodes, and displays closed captions from broadcast, cable, videotape, and DVD signals. As soon as practicable, but not later than July 1, 2002, widescreen digital television (DTV) displays measuring at least 7.8 inches vertically, DTV sets with conventional displays measuring at least 13 inches vertically, and stand-alone DTV tuners, whether or not they are marketed with display screens, and computer equipment that includes DTV receiver or display circuitry, shall be equipped with caption decoder circuitry which appropriately receives, decodes, and displays closed captions from broadcast, cable, videotape, and DVD signals.

(b) Television tuners, including tuner cards for use in computers, shall be equipped with secondary audio program playback circuitry.

(c) All training and informational video and multimedia productions which support the agency's mission, regardless of format, that contain speech or other audio information necessary for the comprehension of the content, shall be open or closed captioned.

(d) All training and informational video and multimedia productions which support the agency's mission, regardless of format, that contain visual information necessary for the comprehension of the content, shall be audio described.

(e) Display or presentation of alternate text presentation or audio descriptions shall be user-selectable unless permanent.

**§ 1194.25 Self contained, closed products.**

(a) Self contained products shall be usable by people with disabilities without requiring an end-user to attach assistive technology to the product. Personal headsets for private listening are not assistive technology.

(b) When a timed response is required, the user shall be alerted and

given sufficient time to indicate more time is required.

(c) Where a product utilizes touchscreens or contact-sensitive controls, an input method shall be provided that complies with § 1194.23 (k) (1) through (4).

(d) When biometric forms of user identification or control are used, an alternative form of identification or activation, which does not require the user to possess particular biological characteristics, shall also be provided.

(e) When products provide auditory output, the audio signal shall be provided at a standard signal level through an industry standard connector that will allow for private listening. The product must provide the ability to interrupt, pause, and restart the audio at anytime.

(f) When products deliver voice output in a public area, incremental volume control shall be provided with output amplification up to a level of at least 65 dB. Where the ambient noise level of the environment is above 45 dB, a volume gain of at least 20 dB above the ambient level shall be user selectable. A function shall be provided to automatically reset the volume to the default level after every use.

(g) Color coding shall not be used as the only means of conveying information, indicating an action, prompting a response, or distinguishing a visual element.

(h) When a product permits a user to adjust color and contrast settings, a range of color selections capable of producing a variety of contrast levels shall be provided.

(i) Products shall be designed to avoid causing the screen to flicker with a frequency greater than 2 Hz and lower than 55 Hz.

(j) Products which are freestanding, non-portable, and intended to be used in one location and which have operable controls shall comply with the following:

(1) The position of any operable control shall be determined with respect to a vertical plane, which is 48 inches in length, centered on the operable control, and at the maximum protrusion of the product within the 48 inch length (see Figure 1 of this part).

**§ 1194.26**

(2) Where any operable control is 10 inches or less behind the reference plane, the height shall be 54 inches maximum and 15 inches minimum above the floor.

(3) Where any operable control is more than 10 inches and not more than 24 inches behind the reference plane, the height shall be 46 inches maximum and 15 inches minimum above the floor.

(4) Operable controls shall not be more than 24 inches behind the reference plane (see Figure 2 of this part).

**§ 1194.26 Desktop and portable computers.**

(a) All mechanically operated controls and keys shall comply with § 1194.23(k)(1) through (4).

(b) If a product utilizes touchscreens or touch-operated controls, an input method shall be provided that complies with § 1194.23 (k) (1) through (4).

(c) When biometric forms of user identification or control are used, an alternative form of identification or activation, which does not require the user to possess particular biological characteristics, shall also be provided.

(d) Where provided, at least one of each type of expansion slots, ports and connectors shall comply with publicly available industry standards.

**Subpart C—Functional Performance Criteria**

**§ 1194.31 Functional performance criteria.**

(a) At least one mode of operation and information retrieval that does not require user vision shall be provided, or support for assistive technology used by people who are blind or visually impaired shall be provided.

(b) At least one mode of operation and information retrieval that does not require visual acuity greater than 20/70

**36 CFR Ch. XI (7–1–03 Edition)**

shall be provided in audio and enlarged print output working together or independently, or support for assistive technology used by people who are visually impaired shall be provided.

(c) At least one mode of operation and information retrieval that does not require user hearing shall be provided, or support for assistive technology used by people who are deaf or hard of hearing shall be provided.

(d) Where audio information is important for the use of a product, at least one mode of operation and information retrieval shall be provided in an enhanced auditory fashion, or support for assistive hearing devices shall be provided.

(e) At least one mode of operation and information retrieval that does not require user speech shall be provided, or support for assistive technology used by people with disabilities shall be provided.

(f) At least one mode of operation and information retrieval that does not require fine motor control or simultaneous actions and that is operable with limited reach and strength shall be provided.

**Subpart D—Information, Documentation, and Support**

**§ 1194.41 Information, documentation, and support.**

(a) Product support documentation provided to end-users shall be made available in alternate formats upon request, at no additional charge.

(b) End-users shall have access to a description of the accessibility and compatibility features of products in alternate formats or alternate methods upon request, at no additional charge.

(c) Support services for products shall accommodate the communication needs of end-users with disabilities.

FIGURES TO PART 1194

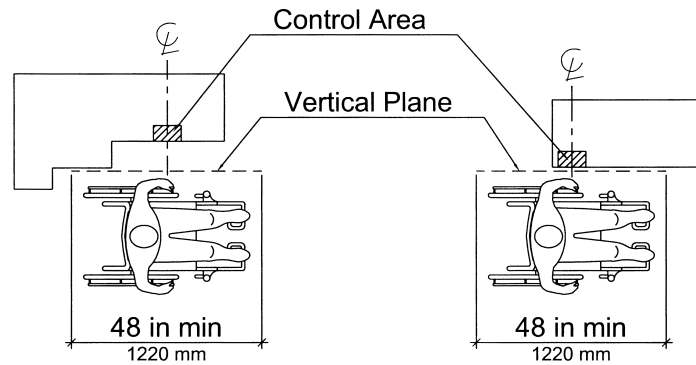

Vertical Plane Relative to the Operable Control

Figure 1

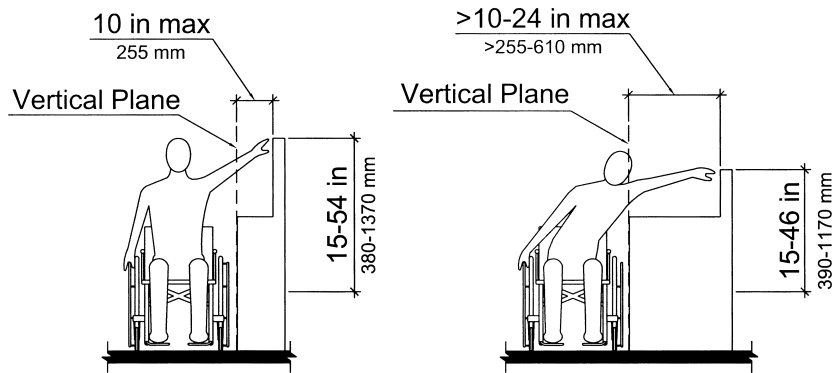

Height of Operable Control Relative to the Vertical Plane

Figure 2

PARTS 1195-1199 [RESERVED]





## CHAPTER XII—NATIONAL ARCHIVES AND RECORDS ADMINISTRATION

---

### SUBCHAPTER A—GENERAL RULES

<i>Part</i>		<i>Page</i>
1200	Official seals .....	541
1201	Collection of claims .....	545
1202	Regulations implementing the Privacy Act of 1974	560
1206	National Historical Publications and Records Commission .....	570
1207	Uniform administrative requirements for grants and cooperative agreements to state and local governments .....	581
1208	Enforcement of nondiscrimination on the basis of handicap in programs or activities conducted by the National Archives and Records Administration .....	608
1209	Governmentwide debarment and suspension (non-procurement) and governmentwide requirements for drug-free workplace (grants) .....	614
1210	Uniform administrative requirements for grants and agreements with institutions of higher education, hospitals, and other non-profit organizations .....	633
1211	Nondiscrimination on the basis of sex in education programs or activities receiving federal financial assistance .....	658

### SUBCHAPTER B—RECORDS MANAGEMENT

1220	Federal records; general .....	680
1222	Creation and maintenance of Federal records .....	687
1228	Disposition of Federal records .....	693
1230	Micrographic records management .....	742
1232	Audiovisual records management .....	751
1234	Electronic records management .....	754
1236	Management of vital records .....	761

36 CFR Ch. XII (7-1-03 Edition)

<i>Part</i>		<i>Page</i>
1238	Program assistance .....	764
	SUBCHAPTER C—PUBLIC AVAILABILITY AND USE	
1250	Public availability and use of Federal Records .....	765
1252	Public use of records, donated historical materials, and facilities; general .....	775
1253	Location of records and hours of use .....	776
1254	Availability of records and donated historical ma- terials .....	779
1256	Restrictions on the use of records .....	799
1258	Fees .....	805
	SUBCHAPTER D—DECLASSIFICATION	
1260	Declassification of national security information ..	809
	SUBCHAPTER E—PRESIDENTIAL RECORDS	
1270	Presidential records .....	815
	SUBCHAPTER F—NIXON PRESIDENTIAL MATERIALS	
1275	Preservation and protection of and access to the Presidential historical materials of the Nixon Administration .....	820
	SUBCHAPTER G—NARA FACILITIES	
1280	Public use of NARA facilities .....	837
1284	Exhibits .....	846
	SUBCHAPTER H—JFK ASSASSINATION RECORDS	
1290	Guidance for interpretation and implementation of the President John F. Kennedy Assassination Records Collection Act of 1992 (JFK Act) .....	848
1291-1299	[Reserved]	

## SUBCHAPTER A—GENERAL RULES

### PART 1200—OFFICIAL SEALS

#### Subpart A—General

Sec.

1200.1 Definitions.

#### Subpart B—How are NARA's Official Seals Designed and Used?

1200.2 How is each NARA seal designed?

1200.4 How does NARA use its official seals?

1200.6 Who is authorized to apply the official seals on documents or other materials?

#### Subpart C—Procedures for the Public to Request and Use NARA Seals

1200.8 How do I request to use the official seals?

1200.10 What are NARA's criteria for approval?

1200.12 How does NARA notify me of the determination?

1200.14 What are NARA's conditions for the use of the official seals?

#### Subpart D—Penalties for Misuse of NARA Seals

1200.16 Will I be penalized for misusing the official seals?

AUTHORITY: 18 U.S.C. 506 and 1017; 44 U.S.C. 2104(e), 2116(b), 2302.

SOURCE: 67 FR 72101, Dec. 4, 2002, unless otherwise noted.

#### Subpart A—General

##### § 1200.1 Definitions.

The following definitions apply to this part:

*Embossing seal* means a display of the form and content of the official seal

made on a die so that the seal can be embossed on paper or other medium.

*NARA* means all organizational units of the National Archives and Records Administration.

*Official seal* means the original(s) of the seal showing the exact form and content.

*Replica or reproduction* means a copy of the official seal displaying the form and content.

#### Subpart B—How are NARA's Official Seals Designed and Used?

##### § 1200.2 How is each NARA seal designed?

NARA's three official seals are illustrated in Figures 1, 2, and 30.

A description of each seal is as follows:

(a) *The National Archives and Records Administration seal*. The design is illustrated below in Figure 1 and described as follows:

(1) The seal is centered on a disc with a double-line border.

(2) The words "NATIONAL ARCHIVES AND RECORDS ADMINISTRATION" encircle the inside of the seal and the date 1985 is at the bottom center.

(3) A solid line rendition of a heraldic eagle displayed holding in its left talon 13 arrows, in its right talon a branch of olive, bearing on its breast a representation of the shield of the United States.

(4) Displayed above the eagle's head is a partially unrolled scroll inscribed with the words "LITTERA SCRIPTA MANET" one above the other.



Figure 1 – The National Archives and Records Administration Seal

(b) *National Archives seal.* The design is illustrated below and described as in paragraph (a) of this section. However, the words "THE NATIONAL AR-

CHIVES OF THE UNITED STATES" encircle the inside of the seal and the date 1934 is at the bottom center.



Figure 2 – The National Archives Seal

(c) *National Archives Trust Fund Board seal.* The design is illustrated below and described as in paragraph (a) of this section. However, the words "NA-

TIONAL ARCHIVES TRUST FUND BOARD" encircle the inside of the seal and the date 1941 is at the bottom center.



Figure 3 – National Archives Trust Fund Board Seal

**§ 1200.4 How does NARA use its official seals?**

NARA uses its three official seals to authenticate various copies of documents and for informational purposes as follows:

(a) The National Archives and Records Administration seal, dated 1985, is used:

(1) For official business, *e.g.*, stationery;

(2) To authenticate copies of Federal records in NARA's temporary custody and copies of NARA operational records; and

(3) For informational purposes with NARA's prior approval (includes use by NARA employees, the public, and other Federal agencies).

(b) The National Archives seal, dated 1934, is used to authenticate copies of documents in NARA's permanent legal custody.

(c) The National Archives Trust Fund Board seal, dated 1941, is used for Trust Fund documents and publications.

**§ 1200.6 Who is authorized to apply the official seals on documents or other materials?**

The Archivist of the United States (and the Archivist's designee) is the only individual authorized to apply NARA official seals, embossing seals, and replicas and reproductions of seals to appropriate documents, authentications, and other material. NARA accepts requests to use the official seals and approves or denies them based on the criteria identified in § 1200.10.

**Subpart C—Procedures for the Public To Request and Use NARA Seals**

**§ 1200.8 How do I request to use the official seals?**

You may only use the official seals if NARA approves your written request. Follow the procedures in this section to request authorization.

(a) Prepare a written request explaining, in detail:

(1) The name of the individual/organization requesting use and how it is associated with NARA;

(2) Which of the three official seals you want to use and how or on what it

is going to be displayed. Provide a sample of the document or other material on which the seal is intended to appear. Mark the sample in all places where the seal would be displayed;

(3) How the intended use of the official seal is connected to your work with NARA on an event or activity (example: requesting to use the official NARA seal on a program brochure, poster, or other publicity announcing a co-sponsored symposium or conference.); and

(4) The dates of the event or activity for which you intend to display the seal.

(b) You must submit the request at least six weeks before you intend to use it to the Archivist of the United States (N), 8601 Adelphi Rd., College Park, MD 20740-6001.

(c) The OMB control number 3095-0052 has been assigned to the information collection contained in this section.

**§ 1200.10 What are NARA's criteria for approval?**

NARA's criteria for approval are as follows:

(a) NARA must be participating in the event or activity by providing speakers, space, or other similar services (example: NARA co-sponsoring a symposium or conference).

(b) The seal is not going to be used on any article or in any manner that reflects unfavorably on NARA or endorses, either directly or by implication, commercial products or services, or a requestor's policies or activities.

**§ 1200.12 How does NARA notify me of the determination?**

NARA will notify you by mail of the final decision, usually within 3 weeks from the date we receive your request. If NARA approves your request, we will send you a camera-ready copy of the official seal along with an approval letter that will:

(a) Reference back to the submitted request (either through the date or another distinguishing characteristic) indicating approval of the specific use, as defined in the request; and

(b) Include NARA's conditions for use, which are identified in § 1200.14.

**§ 1200.14 What are NARA's conditions for the use of the official seals?**

If your request is approved, you must follow these conditions:

(a) Use the official seal only for the specific purpose for which approval was granted;

(b) Submit additional written requests for any uses other than the use granted in the approval letter;

(c) Do not delegate the approval to another individual(s) or organization without NARA's prior approval; and

(d) Do not change the official seals themselves. They must visually and physically appear as illustrated in § 1200.2, with no alterations.

(e) Only use the official seal for the time period designated in the approval letter (example: for the duration of a conference or exhibit).

**Subpart D—Penalties for Misuse of NARA Seals**

**§ 1200.16 Will I be penalized for misusing the official seals?**

(a) If you falsely make, forge, counterfeit, mutilate, or alter official seals, replicas, reproductions or embossing seals, or knowingly use or possess with fraudulent intent any altered seal, you are subject to penalties under 18 U.S.C. 506.

(b) If you use the official seals, replicas, reproductions, or embossing seals in a manner inconsistent with the provisions of this part, you are subject to penalties under 18 U.S.C. 1017 and to other provisions of law as applicable.

**PART 1201—COLLECTION OF CLAIMS**

**Subpart A—Introduction**

Sec.

1201.1 Why is NARA issuing these regulations?

1201.2 Under what authority does NARA issue these regulations?

1201.3 What definitions apply to the regulations in this part?

1201.4 What types of claims are excluded from these regulations?

1201.5 If a claim is not excluded from these regulations, may it be compromised, suspended, terminated, or waived?

1201.6 What is a claim or debt?

## § 1201.1

- 1201.7 Why does NARA have to collect debts?
- 1201.8 What action might NARA take to collect debts?
- 1201.9 What rights do I have as a debtor?

### Subpart B—General Provisions

- 1201.10 Will NARA use a cross-servicing agreement with the Department of the Treasury to collect its claims?
- 1201.11 Will NARA refer claims to the Department of Justice?
- 1201.12 Will NARA provide information to credit reporting agencies?
- 1201.13 How will NARA contract for collection services?
- 1201.14 What should I expect to receive from NARA if I owe a debt to NARA?
- 1201.15 What will the notice tell me regarding collection actions that might be taken if the debt is not paid within 60 days of the notice, or arrangements to pay the debt are not made within 60 days of the notice?
- 1201.16 What will the notice tell me about my opportunity for review of my debt?
- 1201.17 What must I do to obtain a review of my debt, and how will the review process work?
- 1201.18 What interest, penalty charges, and administrative costs will I have to pay on a debt owed to NARA?
- 1201.19 How can I resolve my debt through voluntary repayment?
- 1201.20 What is the extent of the Archivist's authority to compromise debts owed to NARA, or to suspend or terminate collection action on such debts?
- 1201.21 May NARA's failure to comply with these regulations be used as a defense to a debt?

### Subpart C—Salary Offset

- 1201.30 What debts are included or excluded from coverage of these regulations on salary offset?
- 1201.31 May I ask NARA to waive an overpayment that otherwise would be collected by offsetting my salary as a Federal employee?
- 1201.32 What are NARA's procedures for salary offset?
- 1201.33 How will NARA coordinate salary offsets with other agencies?
- 1201.34 Under what conditions will NARA make a refund of amounts collected by salary offset?
- 1201.35 Will the collection of a claim by salary offset act as a waiver of my rights to dispute the claimed debt?

### Subpart D—Tax Refund Offset

- 1201.40 Which debts can NARA refer to the Department of the Treasury for collection by offsetting tax refunds?

## 36 CFR Ch. XII (7–1–03 Edition)

- 1201.41 What are NARA's procedures for collecting debts by tax refund offset?

### Subpart E—Administrative Offset

- 1201.50 Under what circumstances will NARA collect amounts that I owe to NARA (or some other Federal agency) by offsetting the debt against payments that NARA (or some other Federal agency) owes me?
- 1201.51 How will NARA request that my debt to NARA be collected by offset against some payment that another Federal agency owes me?
- 1201.52 What procedures will NARA use to collect amounts I owe to a Federal agency by offsetting a payment that NARA would otherwise make to me?
- 1201.53 When may NARA make an offset in an expedited manner?
- 1201.54 Can a judgment I have obtained against the United States be used to satisfy a debt that I owe to NARA?

### Subpart F—Administrative Wage Garnishment

- 1201.55 How will NARA collect debts through Administrative Wage Garnishment?

AUTHORITY: 5 U.S.C. 5514; 31 U.S.C. 3701–3720A, 3720D; 44 U.S.C. 2104(a).

SOURCE: 67 FR 44757, July 5, 2002, unless otherwise noted.

## Subpart A—Introduction

### § 1201.1 Why is NARA issuing these regulations?

(a) NARA is issuing these regulations to inform the public of procedures that may be used by NARA for the collection of debt.

(b) These regulations provide that NARA will attempt to collect debts owed to it or other Government agencies either directly, or by other means including salary, administrative, tax refund offsets, or administrative wage garnishment.

(c) These regulations also provide that NARA may enter a cross-servicing agreement with the U.S. Department of the Treasury (Treasury) under which the Treasury will take authorized action to collect amounts owed to NARA.

### § 1201.2 Under what authority does NARA issue these regulations?

(a) NARA is issuing the regulations in this part under the authority of 31



U.S.C. Chapter 37, 3701-3720A and 3720D. These sections implement the requirements of the Federal Claims Collection Act of 1966, as amended by the Debt Collection Act of 1982 and the Debt Collection Improvement Act of 1996.

(b) NARA is also issuing the regulations in this part to conform to the Federal Claims Collection Standards (FCCS), which prescribe standards for handling the Federal Government's claims for money or property. The FCCS are issued by the Department of Justice (DOJ) and the Treasury at 31 CFR Chapter IX, Parts 900-904. NARA adopts those standards without change. The regulations in this part supplement the FCCS by prescribing procedures necessary and appropriate for NARA operations.

(c) NARA is also issuing the regulations in this part to conform to the standards for handling Administrative Wage Garnishment processing by the Federal Government. The standards are issued by the Treasury at 31 CFR 285.11. NARA adopts those standards without change. The regulations in this part supplement the standards by prescribing procedures necessary and appropriate for NARA operations.

(d) NARA is further issuing the regulations in this part under the authority of 5 U.S.C. 5514, and the salary offset regulations published by the Office of Personnel and Management at 5 CFR part 550, subpart K.

(e) All of these claims collection regulations are issued under NARA's authority under 44 U.S.C. 2104(a).

#### § 1201.3 What definitions apply to the regulations in this part?

As used in this part:

*Administrative offset* means withholding funds payable by the United States (including funds payable by the United States on behalf of a State government) to, or held by the United States for, a person to satisfy a claim.

*Administrative Wage Garnishment* means a process whereby a Federal agency may, without first obtaining a court order, order an employer to withhold up to 15 percent of your wages for payment to the Federal agency to satisfy a delinquent non-tax debt.

*Agency* means a department, agency, court, court administrative office, or

instrumentality in the executive, judicial, or legislative branch of government, including a government corporation.

*Archivist* means the Archivist of the United States, or his or her designee.

*Certification* means a written statement received by a paying agency or disbursing official from a creditor agency that requests the paying agency or disbursing official to offset the salary of an employee and specifies that required procedural protections have been afforded the employee.

*Claim* (see definition of debt in this section).

*Compromise* means the settlement or forgiveness of a debt.

*Creditor agency* means the agency to which the debt is owed, including a debt collection center when acting on behalf of the creditor agency.

*Day* means calendar day. To count days, include the last day of the period unless it is a Saturday, a Sunday, or a Federal legal holiday.

*Debt collection center* means the Treasury or any other agency or division designated by the Secretary of the Treasury with authority to collect debts on behalf of creditor agencies.

*Debt* and *claim* are deemed synonymous and interchangeable. These terms mean an amount of money, funds, or property that has been determined by an agency official to be due the United States from any person, organization, or entity except another Federal agency. For the purpose of administrative offset under 31 U.S.C. 3716 and subpart E of these regulations, the terms, "debt" and "claim" also include money, funds or property owed by a person to a State (including past-due support being enforced by a State); the District of Columbia; American Samoa; Guam; the United States Virgin Islands; the Commonwealth of the Northern Mariana Islands; or the Commonwealth of Puerto Rico.

*Debtor* means a person, organization, or entity, except another Federal agency, who owes a debt. Use of the terms "I," "you," "me," and similar references to the reader of the regulations in this part are meant to apply to debtors as defined in this paragraph.

*Delinquent debt* means a debt that has not been paid by the date specified in

## § 1201.4

## 36 CFR Ch. XII (7-1-03 Edition)

NARA's initial written demand for payment or applicable agreement or instrument (including a post-delinquency payment agreement), unless other satisfactory payment arrangements have been made.

*Disposable pay* means the part of an employee's pay that remains after deductions that are required to be withheld by law have been made.

*Employee* means a current employee of an agency, including a current member of the Armed Forces or Reserve of the Armed Forces of the United States.

*Federal Claims Collection Standards (FCCS)* means the standards currently published by DOJ and the Treasury at 31 CFR parts 900-904.

NARA means the National Archives and Records Administration.

*Paying agency* means any agency that is making payments of any kind to a debtor. In some cases, NARA may be both the creditor agency and the paying agency.

*Payroll office* means the office that is primarily responsible for payroll records and the coordination of pay matters with the appropriate personnel office.

*Person* includes a natural person or persons, profit or non-profit corporation, partnership, association, trust, estate, consortium, state or local government, or other entity that is capable of owing a debt to the United States; however, agencies of the United States are excluded.

*Private collection contractor* means a private debt collector under contract with an agency to collect a non-tax debt owed to the United States.

*Salary offset* means a payroll procedure to collect a debt under 5 U.S.C. 5514 and 31 U.S.C. 3716 by deduction(s) at one or more officially established pay intervals from the current pay account of an employee, without his or her consent.

*Tax refund offset* means the reduction of a tax refund by the amount of a past-due legally enforceable debt owed to NARA or any other Federal agency.

*Waiver* means the cancellation, remission, forgiveness, or non-recovery of a debt.

*Withholding order* means any order for withholding or garnishment of pay

issued by an agency, or judicial or administrative body.

### § 1201.4 What types of claims are excluded from these regulations?

The following types of claims are excluded:

(a) Debts or claims arising under the Internal Revenue Code (26 U.S.C. 1 *et seq.*) or the tariff laws of the United States, or the Social Security Act (42 U.S.C. 301 *et seq.*); except as provided under sec. 204(f) and 1631 (42 U.S.C. 404(f) and 1383(b)(4)(A)).

(b) Any case to which the Contract Disputes Act (41 U.S.C. 601 *et seq.*) applies;

(c) Any case where collection of a debt is explicitly provided for or provided by another statute, *e.g.*, travel advances under 5 U.S.C. 5705 and employee training expenses under 5 U.S.C. 4108, or, as provided for by title 11 of the United States Code, when the claims involve bankruptcy;

(d) Any debt based in whole or in part on conduct in violation of the antitrust laws or involving fraud, the presentation of a false claim, or misrepresentation on the part of the debtor or any party having an interest in the claim, as described in the FCCS, unless DOJ authorizes NARA to handle the collection;

(e) Claims between Federal agencies;

(f) Unless otherwise provided by law, administrative offset of payments under the authority of 31 U.S.C. 3716 to collect a debt may not be initiated more than 10 years after the Government's right to collect the debt first accrued. (Exception: The 10-year limit does not apply if facts material to the Federal Government's right to collect the debt were not known and could not reasonably have been known by the official or officials of the Government who were charged with the responsibility to discover and collect such debts.) The 10-year limitation also does not apply to debts reduced to a judgment; and

(g) Unless otherwise stated, claims which have been transferred to Treasury or referred to the Department of Justice will be collected in accordance with the procedures of those agencies.

**§ 1201.5 If a claim is not excluded from these regulations, may it be compromised, suspended, terminated, or waived?**

Nothing in this part precludes:

(a) The compromise, suspension, or termination of collection actions, where appropriate under the FCCS, or the use of alternative dispute resolution methods if they are consistent with applicable law and regulations.

(b) An employee from requesting waiver of an erroneous payment under 5 U.S.C. 5584, 10 U.S.C. 2774, or 32 U.S.C. 716, or from questioning the amount or validity of a debt, in the manner set forth in this part.

**§ 1201.6 What is a claim or debt?**

A claim or debt is an amount of money, funds, or property that has been determined by an agency official to be due the United States from any person, organization, or entity except another Federal agency (see § 1201.3).

**§ 1201.7 Why does NARA have to collect debts?**

Federal agencies are required to try to collect claims of the Federal Government for money, funds, or property arising out of the agency's activities.

**§ 1201.8 What action might NARA take to collect debts?**

(a) There are a number of actions that NARA is permitted to take when attempting to collect debts. These actions include:

(1) Salary, tax refund or administrative offset, or administrative wage garnishment (see subparts C, D, E, and F of this part respectively); or

(2) Using the services of private collection contractors.

(b) In certain instances, usually after collection efforts have proven unsuccessful, NARA transfers debts to the Treasury for collection or refers them to the DOJ for litigation (see §§ 1201.10 and 1201.11).

**§ 1201.9 What rights do I have as a debtor?**

As a debtor you have several basic rights. You have a right to:

(a) Notice as set forth in these regulations (see § 1201.14);

(b) Inspect the records that NARA has used to determine that you owe a debt (see § 1201.14);

(c) Request review of the debt and possible payment options (see § 1201.17);

(d) Propose a voluntary repayment agreement (see § 1201.19); and/or

(e) Question if the debt is excluded from these regulations (see § 1201.5(b)).

**Subpart B—General Provisions.**

**§ 1201.10 Will NARA use a cross-servicing agreement with the Department of the Treasury to collect its claims?**

(a) NARA may enter into a cross-servicing agreement that authorizes the Treasury to take the collection actions described in this part on behalf of NARA. This agreement will describe procedures that the Treasury uses to collect debts. The debt collection procedures that the Treasury uses are based on 31 U.S.C. chapter 37.

(b) NARA must transfer to the Treasury any debt that has been delinquent for a period of 180 days or more so that the Secretary of the Treasury may take appropriate action to collect the debt or terminate collection action. NARA may also transfer to the Treasury any debt that is less than 180 days delinquent.

(c) Paragraph (b) of this section will not apply to any debt or claim that:

(1) Is in litigation or foreclosure;

(2) Will be disposed of under an approved asset sales program;

(3) Has been referred to a private collection contractor for collection for a period of time acceptable to the Secretary of the Treasury;

(4) Is at a debt collection center for a period of time acceptable to the Secretary of the Treasury;

(5) Will be collected under internal offset procedures within 3 years after the date the debt or claim is first delinquent; or

(6) Is exempt from this requirement based on a determination by the Secretary of the Treasury.

**§ 1201.11 Will NARA refer claims to the Department of Justice?**

NARA will refer to DOJ for litigation claims on which aggressive collection actions have been taken, but which

## § 1201.12

could not be collected, compromised, suspended, or terminated. Referrals will be made as early as possible, consistent with aggressive NARA collection action, and within the period for bringing a timely suit against the debtor.

### § 1201.12 Will NARA provide information to credit reporting agencies?

(a) NARA will report certain delinquent debts to appropriate consumer credit reporting agencies by providing the following information:

(1) A statement that the debt is valid and overdue;

(2) The name, address, taxpayer identification number, and any other information necessary to establish the identity of the debtor;

(3) The amount, status, and history of the debt; and

(4) The program or pertinent activity under which the debt arose.

(b) Before disclosing debt information to a credit reporting agency, NARA:

(1) Takes reasonable action to locate the debtor if a current address is not available;

(2) Provides the notice required under § 1201.14 if a current address is available; and

(3) Obtains satisfactory assurances from the credit reporting agency that it complies with the Fair Credit Reporting Act (15 U.S.C. 1681 *et seq.*) and other Federal laws governing the provision of credit information.

(c) At the time debt information is submitted to a credit reporting agency, NARA provides a written statement to the reporting agency that all required actions have been taken. In addition, NARA thereafter ensures that the credit reporting agency is promptly informed of any substantive change in the conditions or amount of the debt, and promptly verifies or corrects information relevant to the debt.

(d) If a debtor disputes the validity of the debt, the credit reporting agency refers the matter to the appropriate NARA official. The credit reporting agency excludes the debt from its reports until NARA certifies in writing that the debt is valid.

(e) NARA may disclose to a commercial credit bureau information con-

## 36 CFR Ch. XII (7-1-03 Edition)

cerning a commercial debt, including the following:

(1) Information necessary to establish the name, address, and employer identification number of the commercial debtor;

(2) The amount, status, and history of the debt; and

(3) The program or pertinent activity under which the debt arose.

### § 1201.13 How will NARA contract for collection services?

NARA uses the services of a private collection contractor where it determines that such use is in NARA's best interest. When NARA determines that there is a need to contract for collection services, NARA:

(a) Retains sole authority to:

(1) Resolve any dispute with the debtor or regarding the validity of the debt;

(2) Compromise the debt;

(3) Suspend or terminate collection action;

(4) Refer the debt to the DOJ for litigation; and

(5) Take any other action under this part;

(b) Requires the contractor to comply with the:

(1) Privacy Act of 1974, as amended, to the extent specified in 5 U.S.C. 552a(m);

(2) Fair Debt Collection Practices Act (15 U.S.C. 1692-1692o); and

(3) Other applicable Federal and State laws pertaining to debt collection practices and applicable regulations of NARA in this part;

(c) Requires the contractor to account accurately and fully for all amounts collected; and

(d) Requires the contractor to provide to NARA, upon request, all data and reports contained in its files related to its collection actions on a debt.

### § 1201.14 What should I expect to receive from NARA if I owe a debt to NARA?

(a) NARA will send you a written notice when we determine that you owe a debt to NARA. The notice will be hand-delivered or sent to you at the most current address known to NARA. The notice will inform you of the following:

(1) The amount, nature, and basis of the debt;

(2) That a designated NARA official has reviewed the claim and determined that it is valid;

(3) That payment of the debt is due as of the date of the notice, and that the debt will be considered delinquent if you do not pay it within 30 days of the date of the notice;

(4) NARA's policy concerning interest, penalty charges, and administrative costs (see §1201.18), including a statement that such assessments must be made against you unless excused in accordance with the FCCS and this part;

(5) That you have the right to inspect and copy disclosable NARA records pertaining to your debt, or to receive copies of those records if personal inspection is impractical;

(6) That you have the opportunity to enter into an agreement, in writing and signed by both you and the designated NARA official, for voluntary repayment of the debt (see §1201.19);

(7) The address, telephone number, and name of the NARA official available to discuss the debt;

(8) Possible collection actions that might be taken if the debt is not paid within 60 days of the notice, or arrangements to pay the debt are not made within 60 days of the notice (see §1201.15 for a fuller description of possible actions);

(9) That NARA may suspend or revoke any licenses, permits, or other privileges for failure to pay a debt; and

(10) Information on your opportunity to obtain a review of the debt (see §1201.16).

(b) NARA will respond promptly to communications from you.

(c) Exception to entitlement to notice, hearing, written responses, and final decisions. With respect to the regulations covering internal salary offset collections (see §1230.32), NARA excepts from the provisions of paragraph (a) of this section—

(1) Any adjustment to pay arising out of an employee's election of coverage or a change in coverage under a Federal benefits program requiring periodic deductions from pay, if the amount to be recovered was accumulated over 4 pay periods or less;

(2) A routine intra-agency adjustment of pay that is made to correct an overpayment of pay attributable to clerical or administrative errors or delays in processing pay documents, if the overpayment occurred within the 4 pay periods preceding the adjustment and, at the time of such adjustment, or as soon thereafter as practical, the individual is provided written notice of the nature and the amount of the adjustment and point of contact for contesting such adjustment; or

(3) Any adjustment to collect a debt amounting to \$50 or less, if, at the time of such adjustment, or as soon thereafter as practical, the individual is provided written notice of the nature and the amount of the adjustment and a point of contact for contesting such adjustment.

**§1201.15 What will the notice tell me regarding collection actions that might be taken if the debt is not paid within 60 days of the notice, or arrangements to pay the debt are not made within 60 days of the notice?**

The notice provided under §1201.14 will advise you that within 60 days of the date of the notice, your debt (including any interest, penalty charges, and administrative costs) must be paid or you must enter into a voluntary repayment agreement. If you do not pay the debt or enter into the agreement within that deadline, NARA may enforce collection of the debt by any or all of the following methods:

(a) By referral to a credit reporting agency (see §1201.12), private collection contractor (see §1201.13), or the DOJ (see §1201.11).

(b) By transferring any debt to the Treasury for collection, including under a cross-servicing agreement with the Treasury (see §1201.10).

(c) If you are a NARA employee, by deducting money from your disposable pay account until the debt (and all accumulated interest, penalty charges, and administrative costs) is paid in full (see subpart C of this part). NARA will specify the amount, frequency, approximate beginning date, and duration of the deduction. 5 U.S.C. 5514 and 31 U.S.C. 3716 govern such proceedings;

## § 1201.16

## 36 CFR Ch. XII (7-1-03 Edition)

(d) If you are an employee of a Federal agency other than NARA, by initiating certification procedures to implement a salary offset by that Federal agency (*see* subpart C of this part). 5 U.S.C. 5514 governs such proceedings;

(e) By referring the debt to the Treasury for offset against any refund of overpayment of tax (*see* subpart D of this part);

(f) By administrative offset (*see* subpart E of this part);

(g) By administrative wage garnishment (*see* subpart F of this part); or

(h) By liquidation of security or collateral. NARA has the right to hold security or collateral, liquidate it, and apply the proceeds to your debt through the exercise of a power of sale in the security instrument or a foreclosure. NARA will not follow the procedures in this paragraph (h) if the cost of disposing the collateral will be disproportionate to its value.

### **§ 1201.16 What will the notice tell me about my opportunity for review of my debt?**

The notice provided by NARA under §§ 1201.14 and 1201.15 will also advise you of the opportunity to obtain a review within NARA concerning the existence or amount of the debt or the proposed schedule for offset of Federal employee salary payments. The notice will also advise you of the following:

(a) The name, address, and telephone number of a NARA official whom you may contact concerning procedures for requesting a review;

(b) The method and time period for requesting a review;

(c) That the filing of a request for a review on or before the 60th day following the date of the notice will stay the commencement of collection proceedings;

(d) The name and address of the NARA official to whom you should send the request for a review;

(e) That a final decision on the review (if one is requested) will be issued in writing at the earliest practical date, but not later than 60 days after the receipt of the request for a review, unless you request, and the review official grants, a delay in the proceedings;

(f) That any knowingly false or frivolous statements, representations, or evidence may subject you to:

(1) Disciplinary procedures appropriate under 5 U.S.C. Chapter 75, 5 CFR part 752, or any other applicable statute or regulations;

(2) Penalties under the False Claims Act (31 U.S.C. 3729-3733) or any other applicable statutory authority; and

(3) Criminal penalties under 18 U.S.C. 286, 287, 1001, and 1002, or any other applicable statutory authority;

(g) Any other rights available to you to dispute the validity of the debt or to have recovery of the debt waived, or remedies available to you under statutes or regulations governing the program for which the collection is being made; and

(h) That unless there are applicable contractual or statutory provisions to the contrary, amounts paid on or deducted for the debt that are later waived or found not owed will be promptly refunded to you.

### **§ 1201.17 What must I do to obtain a review of my debt, and how will the review process work?**

(a) *Request for review.* (1) You have the right to request a review by NARA of the existence or amount of your debt, the proposed schedule for offset of Federal employee salary payments, or whether the debt is past due or legally enforceable. If you want a review, you must send a written request to the NARA official designated in the notice (*see* § 1201.16(d)).

(2) You must sign your request for review and fully identify and explain with reasonable specificity all the facts, evidence, and witnesses that support your position. Your request for review should be accompanied by available evidence to support your contentions.

(3) Your request for review must be received by the designated officer or employee of NARA on or before the 60th calendar day following the date of the notice. Timely filing will stay the commencement of collection procedures. NARA may consider requests filed after the 60-day period provided for in this section if you:

(i) Can show that the delay was the result of circumstances beyond your control; or

(ii) Did not receive notice of the filing deadline (unless you had actual notice of the filing deadline).

(b) *Inspection of NARA records related to the debt.* (1) If you want to inspect or copy NARA records related to the debt (see § 1201.14(a)(5)), you must send a letter to the NARA official designated in the notice. Your letter must be received within 30 days of the date of the notice.

(2) In response to the timely request described in paragraph (b)(1) of this section, the designated NARA official will notify you of the location and time when you may inspect and copy records related to the debt.

(3) If personal inspection of NARA records related to the debt is impractical, reasonable arrangements will be made to send you copies of those records.

(c) *Review official.* (1) When required by Federal law or regulation, such as in a salary offset situation, NARA will request an administrative law judge, or hearing official from another agency who is not under the supervision or control of the Archivist, to conduct the review. In these cases, the hearing official will, following the review, submit the review decision to the Archivist for the issuance of NARA's final decision (see paragraph (f) of this section for content of the review decision).

(2) When Federal law or regulation does not require NARA to have the review conducted by an administrative law judge, or by a hearing official from another agency who is not under the supervision or control of the Archivist, NARA has the right to appoint a hearing official to conduct the review. In these cases, the hearing official will, following the review, submit the review decision to the Archivist for the issuance of NARA's final decision (see paragraph (f) of this section for the content of the review decision).

(d) *Review procedure.* If you request a review, the review official will notify you of the form of the review to be provided. The review official will determine whether an oral hearing is required, or if a review of the written

record is sufficient, in accordance with the FCCS. Although you may request an oral hearing, such a hearing is required only when a review of the documentary evidence cannot determine the question of indebtedness, such as when the validity of the debt turns on an issue of credibility or truthfulness. In either case, the review official will conduct the review in accordance with the FCCS. If the review will include an oral hearing, the notice sent to you by the review official will set forth the date, time, and location of the hearing.

(e) *Date of decision.* (1) The review official will issue a written decision, based upon either the written record or documentary evidence and information developed at an oral hearing. This decision will be issued as soon as practical, but not later than 60 days after the date on which NARA received your request for a review, unless you request, and the review official grants, a delay in the proceedings.

(2) If NARA is unable to issue a decision within 60 days after the receipt of the request for a hearing:

(i) NARA may not issue a withholding order or take other action until the hearing (in whatever form) is held and a decision is rendered; and

(ii) If NARA previously issued a withholding order to the debtor's employer, NARA must suspend the withholding order beginning on the 61st day after the receipt of the hearing request and continuing until a hearing (in whatever form) is held and a decision is rendered.

(f) *Content of review decision.* The review official will prepare a written decision that includes:

(1) A statement of the facts presented to support the origin, nature, and amount of the debt;

(2) The review official's findings, analysis, and conclusions; and

(3) The terms of any repayment schedule, if applicable.

(g) *Interest, penalty charge, and administrative cost accrual during review period.* Interest, penalty charges, and administrative costs authorized by law will continue to accrue during the review period.

§ 1201.18

36 CFR Ch. XII (7-1-03 Edition)

**§ 1201.18 What interest, penalty charges, and administrative costs will I have to pay on a debt owed to NARA?**

(a) *Interest.* (1) NARA will assess interest on all delinquent debts unless prohibited by statute, regulation, or contract.

(2) Interest begins to accrue on all debts from the date that the debt becomes delinquent. NARA will not recover interest if you pay the debt within 30 days of the date on which interest begins to accrue. NARA will assess interest at the rate established annually by the Secretary of the Treasury under 31 U.S.C. 3717, unless a different rate is either necessary to protect the interests of NARA or established by a contract, repayment agreement, or statute. NARA will notify you of the basis for its finding when a different rate is necessary to protect the interests of NARA.

(3) The Archivist may extend the 30-day period for payment without interest where he or she determines that such action is in the best interest of NARA. A decision to extend or not to extend the payment period is final and is not subject to further review.

(b) *Penalty.* NARA will assess a penalty charge of 6 percent a year on any portion of a debt that is delinquent for more than 90 days.

(c) *Administrative costs.* NARA will assess charges to cover administrative costs incurred as a result of your failure to pay a debt before it becomes delinquent. Administrative costs include the additional costs incurred in processing and handling the debt because it became delinquent, such as costs incurred in obtaining a credit report or in using a private collection contractor, or service fees charged by a Federal agency for collection activities undertaken on behalf of NARA.

(d) *Allocation of payments.* A partial or installment payment by a debtor will be applied first to outstanding penalty assessments, second to administrative costs, third to accrued interest, and fourth to the outstanding debt principal.

(e) *Additional authority.* NARA may assess interest, penalty charges, and administrative costs on debts that are not subject to 31 U.S.C. 3717 to the ex-

tent authorized under common law or other applicable statutory authority.

(f) *Waiver.* (1) The Archivist may (without regard to the amount of the debt) waive collection of all or part of accrued interest, penalty charges, or administrative costs, if he or she determines that collection of these charges would be against equity and good conscience or not in the best interest of NARA.

(2) A decision to waive interest, penalty charges, or administrative costs may be made at any time before a debt is paid. However, and unless otherwise stated in these regulations, where these charges have been collected before the waiver decision, they will not be refunded. The Archivist's decision to waive or not waive collection of these charges is final and is not subject to further review.

**§ 1201.19 How can I resolve my debt through voluntary repayment?**

(a) In response to a notice of debt, you may propose to NARA that you be allowed to repay the debt through a voluntary repayment agreement in lieu of NARA taking other collection actions under this part.

(b) Your request to enter into a voluntary repayment agreement must:

(1) Be in writing;

(2) Admit the existence of the debt; and

(3) Either propose payment of the debt (together with interest, penalty charges, and administrative costs) in a lump sum, or set forth a proposed repayment schedule.

(c) NARA will collect claims in one lump sum whenever feasible. However, if you are unable to pay your debt in one lump sum, NARA may accept payment in regular installments that bear a reasonable relationship to the size of the debt and your ability to pay.

(d) NARA will consider a request to enter into a voluntary repayment agreement in accordance with the FCCS. The Archivist may request additional information from you, including financial statements if you request to make payments in installments, in order to determine whether to accept a voluntary repayment agreement. It is within the Archivist's discretion to accept a repayment agreement instead of



proceeding with other collection actions under this part, and to set the necessary terms of any voluntary repayment agreement. No repayment agreement will be binding on NARA unless it is in writing and signed by both you and the Archivist. At NARA's option, you may be required to provide security as part of the agreement to make payments in installments. Notwithstanding the provisions of this section, 31 U.S.C. 3711 will govern any reduction or compromise of a claim.

**§ 1201.20 What is the extent of the Archivist's authority to compromise debts owed to NARA, or to suspend or terminate collection action on such debts?**

(a) The Archivist may compromise, suspend, or terminate collection action on those debts owed to NARA that do not exceed \$100,000 excluding interest, in conformity with the Federal Claims Collection Act of 1966, as amended. NARA will follow the policies in §902.2 of the FCCS.

(b) The uncollected portion of a debt owed to NARA that is not recovered as the result of a compromise will be reported to the Internal Revenue Service (IRS) as income to the debtor in accordance with IRS procedures if the debt is at least \$600.00.

**§ 1201.21 May NARA's failure to comply with these regulations be used as a defense to a debt?**

No, the failure of NARA to comply with any standard in the FCCS or these regulations will not be available to any debtor as a defense.

### Subpart C—Salary Offset

**§ 1201.30 What debts are included or excluded from coverage of these regulations on salary offset?**

(a) The regulations in this subpart provide NARA procedures for the collection by salary offset of a Federal employee's pay to satisfy certain debts owed to NARA or to other Federal agencies.

(b) The regulations in this subpart do not apply to any case where collection of a debt by salary offset is explicitly provided for or prohibited by another statute.

(c) Nothing in the regulations in this subpart precludes the compromise, suspension, or termination of collection actions under the Federal Claims Collection Act of 1966, as amended, or the FCCS.

(d) A levy imposed under the Internal Revenue Code takes precedence over a salary offset under this subpart, as provided in 5 U.S.C. 5514(d).

**§ 1201.31 May I ask NARA to waive an overpayment that otherwise would be collected by offsetting my salary as a Federal employee?**

Yes, the regulations in this subpart do not preclude you from requesting waiver of an overpayment under 5 U.S.C. 5584 or 8346(b), 10 U.S.C. 2774, 32 U.S.C. 716, or other statutory provisions pertaining to the particular debts being collected.

**§ 1201.32 What are NARA's procedures for salary offset?**

(a) NARA will coordinate salary deductions under this subpart as appropriate.

(b) If you are a NARA employee who owes a debt to NARA, NARA's payroll office will determine the amount of your disposable pay and will implement the salary offset.

(c) Deductions will begin within three official pay periods following receipt by NARA's payroll office of certification of debt from the creditor agency.

(d) The Notice provisions of these regulations do not apply to certain debts arising under this section (see §1201.14(c)).

(e) Types of collection. (1) *Lump-sum offset*. If the amount of the debt is equal to or less than 15 percent of disposable pay, the debt generally will be collected through one lump-sum offset.

(2) *Installment deductions*. Installment deductions will be made over a period not greater than the anticipated period of employment. The size and frequency of installment deductions will bear a reasonable relation to the size of the debt and your ability to pay. However, the amount deducted from any period will not exceed 15 percent of the disposable pay from which the deduction is made unless you have agreed in writing to the deduction of a greater amount.

### § 1201.33

### 36 CFR Ch. XII (7-1-03 Edition)

If possible, installment payments will be sufficient in size and frequency to liquidate the debt in three years or less.

(3) *Deductions from final check.* A deduction exceeding the 15 percent of disposable pay limitation may be made from any final salary payment under 31 U.S.C. 3716 and the FCCS in order to liquidate the debt, whether the employee is being separated voluntarily or involuntarily.

(4) *Deductions from other sources.* If an employee subject to salary offset is separated from NARA and the balance of the debt cannot be liquidated by offset of the final salary check, NARA may offset later payments of any kind against the balance of the debt, as allowed by 31 U.S.C. 3716 and the FCCS.

(f) *Multiple debts.* In instances where two or more creditor agencies are seeking salary offsets, or where two or more debts are owed to a single creditor agency, NARA's payroll office may, at its discretion, determine whether one or more debts should be offset simultaneously within the 15 percent limitation.

#### § 1201.33 How will NARA coordinate salary offsets with other agencies?

(a) *Responsibilities of NARA as the creditor agency (i.e. when the debtor owes a debt to NARA and is an employee of another agency).* Upon completion of the procedures established in this subpart and pursuant to 5 U.S.C. 5514 and 31 U.S.C. 3716, NARA must submit a claim to a paying agency or disbursing official.

(1) In its claim, NARA must certify, in writing, the following:

- (i) That the employee owes the debt;
- (ii) The amount and basis of the debt;
- (iii) The date NARA's right to collect the debt first accrued;
- (iv) That NARA's regulations in this subpart have been approved by OPM under 5 CFR part 550, subpart K; and
- (v) That NARA has met the certification requirements of the paying agency.

(2) If the collection must be made in installments, NARA's claim will also advise the paying agency of the amount or percentage of disposable pay to be collected in each installment. NARA may also advise the paying

agency of the number of installments to be collected and the date of the first installment, if that date is other than the next officially established pay period.

(3) NARA will also include in its claim:

(i) The employee's written consent to the salary offset;

(ii) The employee's signed statement acknowledging receipt of the procedures required by 5 U.S.C. 5514; or

(iii) Information regarding the completion of procedures required by 5 U.S.C. 5514, including the actions taken and the dates of those actions.

(4) If the employee is in the process of separating and has not received a final salary check or other final payment(s) from the paying agency, NARA must submit its claim to the paying agency or disbursing official for collection under 31 U.S.C. 3716. The paying agency will (under its regulations adopted under 5 U.S.C. 5514 and 5 CFR part 550, subpart K), certify the total amount of its collection on the debt and notify the employee and NARA. If the paying agency's collection does not fully satisfy the debt, and the paying agency is aware that the debtor is entitled to payments from the Civil Service Retirement and Disability Fund or other similar payments that may be due the debtor employee from other Federal government sources, then (under its regulations adopted under 5 U.S.C. 5514 and 5 CFR part 550, subpart K), the paying agency will provide written notice of the outstanding debt to the agency responsible for making the other payments to the debtor employee. The written notice will state that the employee owes a debt, the amount of the debt, and that the provisions of this section have been fully complied with. However, NARA must submit a properly certified claim under this paragraph (a)(4) to the agency responsible for making the other payments before the collection can be made.

(5) If the employee is already separated and all payments due from his or her former paying agency have been paid, NARA may request, unless otherwise prohibited, that money due and payable to the employee from the Civil Service Retirement and Disability

Fund or other similar funds be administratively offset to collect the debt.

(6) *Employee transfer.* When an employee transfers from one paying agency to another paying agency, NARA will not repeat the due process procedures described in 5 U.S.C. 5514 and this subpart to resume the collection. NARA will submit a properly certified claim to the new paying agency and will subsequently review the debt to ensure that the collection is resumed by the new paying agency.

(b) *Responsibilities of NARA as the paying agency (i.e. when the debtor owes a debt to another agency and is an employee of NARA).* (1) Complete claim. When NARA receives a certified claim from a creditor agency (under the creditor agency's regulations adopted under 5 U.S.C. 5514 and 5 CFR part 550, subpart K), deductions should be scheduled to begin within three officially established pay intervals. Before deductions can begin, NARA sends the employee a written notice containing:

(i) A statement that NARA has received a certified claim from the creditor agency;

(ii) The amount of the claim;

(iii) The date salary offset deductions will begin; and

(iv) The amount of such deductions.

(2) Incomplete claim. When NARA receives an incomplete certification of debt from a creditor agency, NARA will return the claim with a notice that the creditor agency must:

(i) Comply with the procedures required under 5 U.S.C. 5514 and 5 CFR part 550, subpart K, and

(ii) Properly certify a claim to NARA before NARA will take action to collect from the employee's current pay account.

(3) NARA is not authorized to review the merits of the creditor agency's determination with respect to the amount or validity of the debt certified by the creditor agency.

(4) Employees who transfer from NARA to another paying agency. If, after the creditor agency has submitted the claim to NARA, the employee transfers from NARA to a different paying agency before the debt is collected in full, NARA will certify the total amount collected on the debt and notify the employee and the creditor

agency in writing. The notification to the creditor agency will include information on the employee's transfer.

**§ 1201.34 Under what conditions will NARA make a refund of amounts collected by salary offset?**

(a) If NARA is the creditor agency, it will promptly refund any amount deducted under the authority of 5 U.S.C. 5514, when:

(1) The debt is waived or all or part of the funds deducted are otherwise found not to be owed (unless expressly prohibited by statute or regulation); or

(2) An administrative or judicial order directs NARA to make a refund.

(b) Unless required or permitted by law or contract, refunds under this section will not bear interest.

**§ 1201.35 Will the collection of a claim by salary offset act as a waiver of my rights to dispute the claimed debt?**

No, your involuntary payment of all or any portion of a debt under this subpart will not be construed as a waiver of any rights that you may have under 5 U.S.C. 5514 or other provisions of a law or written contract, unless there are statutory or contractual provisions to the contrary.

**Subpart D—Tax Refund Offset**

**§ 1201.40 Which debts can NARA refer to the Treasury for collection by offsetting tax refunds?**

(a) The regulations in this subpart implement 31 U.S.C. 3720A, which authorizes the Treasury to reduce a tax refund by the amount of a past-due, legally enforceable debt owed to a Federal agency.

(b) For purposes of this section, a past-due, legally enforceable debt referable to the Treasury for tax refund offset is a debt that is owed to NARA and:

(1) Is at least \$25.00;

(2) Except in the case of a judgment debt, has been delinquent for at least three months and will not have been delinquent more than 10 years at the time the offset is made;

(3) With respect to which NARA has:

(i) Given the debtor at least 60 days to present evidence that all or part of

## § 1201.41

the debt is not past due or legally enforceable;

(ii) Considered evidence presented by the debtor; and

(iii) Determined that an amount of the debt is past due and legally enforceable;

(4) With respect to which NARA has notified or has made a reasonable attempt to notify the debtor that:

(i) The debt is past due, and

(ii) Unless repaid within 60 days of the date of the notice, the debt may be referred to the Treasury for offset against any refund of overpayment of tax; and

(5) All other requirements of 31 U.S.C. 3720A and the Treasury regulations relating to the eligibility of a debt for tax return offset (31 CFR 285.2) have been satisfied.

### § 1201.41 What are NARA's procedures for collecting debts by tax refund offset?

(a) NARA's Financial Services Division will be the point of contact with the Treasury for administrative matters regarding the offset program.

(b) NARA will ensure that the procedures prescribed by the Treasury are followed in developing information about past-due debts and submitting the debts to the Treasury.

(c) NARA will submit to the Treasury a notification of a taxpayer's liability for past-due legally enforceable debt. This notification will contain the following:

(1) The name and taxpayer identification number of the debtor;

(2) The amount of the past-due and legally enforceable debt;

(3) The date on which the original debt became past due;

(4) A statement certifying that, with respect to each debt reported, all of the requirements of § 1201.40(b) have been satisfied; and

(5) Any other information as prescribed by Treasury.

(d) For purposes of this section, notice that collection of the debt is stayed by a bankruptcy proceeding involving the debtor will bar referral of the debt to the Treasury.

(e) NARA will promptly notify the Treasury to correct data when NARA:

## 36 CFR Ch. XII (7-1-03 Edition)

(1) Determines that an error has been made with respect to a debt that has been referred;

(2) Receives or credits a payment on the debt; or

(3) Receives notice that the person owing the debt has filed for bankruptcy under Title 11 of the United States Code and the automatic stay is in effect or has been adjudicated bankrupt and the debt has been discharged.

(f) When advising debtors of NARA's intent to refer a debt to the Treasury for offset, NARA will also advise debtors of remedial actions (see §§ 1201.9 and 1201.14 through 1201.16 of this part) available to defer the offset or prevent it from taking place.

### Subpart E—Administrative Offset

#### § 1201.50 Under what circumstances will NARA collect amounts that I owe to NARA (or some other Federal agency) by offsetting the debt against payments that NARA (or some other Federal agency) owes me?

(a) The regulations in this subpart apply to the collection of any debts you owe to NARA, or to any request from another Federal agency that NARA collect a debt you owe by offsetting your debt against a payment NARA owes you. Administrative offset is authorized under section 5 of the Federal Claims Collection Act of 1966, as amended (31 U.S.C. 3716). NARA will carry out administrative offset in accordance with the provisions of the FCCS. The regulations in this subpart are intended only to supplement the provisions of the Federal Claims Collection Standards.

(b) The Archivist, after attempting to collect a debt you owe to NARA under Section 3(a) of the Federal Claims Collection Act of 1966, as amended (31 U.S.C. 3711(a)), may collect the debt by administrative offset only after giving you:

(1) Written notice of the type and amount of the claim, the intention of the head of the agency to collect the claim by administrative offset, and an explanation of the rights of the debtor;

(2) An opportunity to inspect and copy the records of the agency related to the claim;

(3) An opportunity for a review within the agency of the decision of the agency related to the claim; and

(4) An opportunity to make a written agreement with the head of the agency to repay the amount of the claim.

(c) No collection by administrative offset will be made on any debt that has been outstanding for more than 10 years, unless facts material to NARA or a Federal agency's right to collect the debt were not known, and reasonably could not have been known, by the official or officials responsible for discovering and collecting the debt.

(d) The regulations in this subpart do not apply to:

(1) A case in which administrative offset of the type of debt involved is explicitly prohibited by statute; or

(2) Debts owed to NARA by Federal agencies.

**§ 1201.51 How will NARA request that my debt to NARA be collected by offset against some payment that another Federal agency owes me?**

The Archivist may request that funds due and payable to you by another Federal agency instead be paid to NARA to satisfy a debt you owe to NARA. NARA will refer debts to the Treasury for centralized administrative offset in accordance with the FCCS and the procedures established by the Treasury. Where centralized offset is not available or appropriate, NARA may request offset directly from the Federal agency that is holding funds for you. In requesting administrative offset, NARA will certify in writing to the Federal agency that is holding funds for you:

(a) That you owe the debt;

(b) The amount and basis of the debt; and

(c) That NARA has complied with the requirements of 31 U.S.C. 3716, its own administrative offset regulations in this subpart, the applicable administrative offset regulations of the agency holding the funds, and the applicable provisions of the FCCS with respect to providing you with due process.

**§ 1201.52 What procedures will NARA use to collect amounts I owe to a Federal agency by offsetting a payment that NARA would otherwise make to me?**

(a) Any Federal agency may request that NARA administratively offset funds due and payable to you in order to collect a debt you owe to that agency. NARA will initiate the requested offset only upon:

(1) Receipt of written certification from the creditor agency stating:

(i) That you owe the debt;

(ii) The amount and basis of the debt;

(iii) That the agency has prescribed regulations for the exercise of administrative offset; and

(iv) That the agency has complied with its own administrative offset regulations and with the applicable provisions of the FCCS, including providing you with any required hearing or review; and

(2) A determination by the Archivist that offsetting funds payable to you by NARA in order to collect a debt owed by you would be in the best interest of the United States as determined by the facts and circumstances of the particular case, and that such an offset would not otherwise be contrary to law.

(b) *Multiple debts.* In instances where two or more creditor agencies are seeking administrative offsets, or where two or more debts are owed to a single creditor agency, NARA may, in its discretion, allocate the amount it owes to you to the creditor agencies in accordance with the best interest of the United States as determined by the facts and circumstances of the particular case, paying special attention to applicable statutes of limitations.

**§ 1201.53 When may NARA make an offset in an expedited manner?**

NARA may effect an administrative offset against a payment to be made to you before completion of the procedures required by §§ 1201.51 and 1201.52 if failure to take the offset would substantially jeopardize NARA's ability to collect the debt and the time before the

## § 1201.54

payment is to be made does not reasonably permit the completion of those procedures. An expedited offset will be followed promptly by the completion of those procedures. Amounts recovered by offset, but later found not to be owed to the United States, will be promptly refunded.

### § 1201.54 Can a judgment I have obtained against the United States be used to satisfy a debt that I owe to NARA?

Collection by offset against a judgment obtained by a debtor against the United States will be accomplished in accordance with 31 U.S.C. 3728 and 31 U.S.C. 3716.

### Subpart F—Administrative Wage Garnishment

#### § 1201.55 How will NARA collect debts through Administrative Wage Garnishment?

NARA will collect debts through Administrative Wage Garnishment in accordance with the Administrative Wage Garnishment regulations issued by the Treasury. NARA adopts, for the purposes of this subpart, the Treasury's Administrative Wage Garnishment regulations in 31 CFR 285.11.

## PART 1202—REGULATIONS IMPLEMENTING THE PRIVACY ACT OF 1974

### Subpart A—General Information About the Privacy Act

Sec.

- 1202.1 What does this part cover?
- 1202.2 What this part does not cover.
- 1202.4 Definitions.
- 1202.6 Whom should I contact for Privacy Act matters at NARA?
- 1202.8 How does NARA handle records that are in Government-wide Privacy Act systems?
- 1202.10 Does NARA handle access to and disclosure of records of defunct agencies in the custody of NARA?

### Subpart B—Collecting Information

- 1202.18 How does NARA collect information about individuals?
- 1202.20 What advisory information does NARA provide before collecting information from me?

## 36 CFR Ch. XII (7–1–03 Edition)

- 1202.22 Will NARA need my Social Security Number?
- 1202.24 Will NARA ever request information about me from someone else?
- 1202.26 Who will make sure that my record is accurate?
- 1202.28 What rules do NARA employees follow in managing personal information?
- 1202.30 How does NARA safeguard its systems of records?

### Subpart C—Individual Access to Records

- 1202.40 How can I gain access to NARA records about myself?
- 1202.42 How are requests for access to medical records handled?
- 1202.44 How long will it take for NARA to process my request?
- 1202.46 In what ways will NARA provide access?
- 1202.48 Will I have to pay for copies of records?
- 1202.50 Does NARA require prepayment of fees?
- 1202.52 How do I pay?
- 1202.54 On what grounds can NARA deny my Privacy Act request?
- 1202.56 How do I appeal a denial of my Privacy Act request?
- 1202.58 How are appeals processed?

### Subpart D—Disclosure of Records

- 1202.60 When does NARA disclose a record in a Privacy Act system of records?
- 1202.62 What are the procedures for disclosure of records to a third party?
- 1202.64 How do I appeal a denial of disclosure?
- 1202.66 How does NARA keep account of disclosures?

### Subpart E—Request to Amend Records

- 1202.70 Whom should I contact at NARA to amend records about myself?
- 1202.72 How does NARA handle requests to amend records?
- 1202.74 How will I know if NARA approved my amendment request?
- 1202.76 Can NARA deny my request for amendment?
- 1202.78 How do I accept an alternative amendment?
- 1202.80 How do I appeal the denial of a request to amend a record?
- 1202.82 How do I file a Statement of Disagreement?
- 1202.84 Can I seek judicial review?

### Subpart F—Exemptions

- 1202.90 What NARA systems of records are exempt from release under the National Security Exemption of the Privacy Act?

1202.92 What NARA systems of records are exempt from release under the Law Enforcement Exemption of the Privacy Act?

1202.94 What NARA systems of records are exempt from release under the Investigatory Information Material Exemption of the Privacy Act?

AUTHORITY: 5 U.S.C. 552a; 44 U.S.C. 2104(a).

SOURCE: 66 FR 65652, Dec. 20, 2001, unless otherwise noted.

### Subpart A—General Information About the Privacy Act

#### § 1202.1 What does this part cover?

(a) This part covers requests under the Privacy Act (5 U.S.C. 552a) for NARA operational records and records of defunct agencies stored in NARA record centers.

(b) This part explains how NARA collects, uses and maintains records about you that are filed by your name or other personal identifiers and which are contained in a “system of records” as defined by 5 U.S.C. 552a(a)(5).

(c) This part describes the procedures to gain access to and contest the contents of your records, and the conditions under which NARA discloses such records to others.

#### § 1202.2 What this part does not cover.

This part does not cover:

(a) Records that have been transferred into the National Archives of the United States for permanent preservation. Archival records that are contained in systems of records that become part of the National Archives of the United States are exempt from most provisions of the Privacy Act (see 5 U.S.C. 552a(l)(2) and (l)(3)). See subchapter C of this chapter for rules governing access to these type records.

(b) Records of other agencies that are stored in NARA record centers on behalf of that agency are governed by the Privacy Act rules of the transferring agency. Send your request for those records directly to those agencies.

(c) Personnel and medical records held by the National Personnel Records Center (NPRC) on behalf of the Department of Defense and the Office of Personnel Management. Privacy Act requests for these records should come to the NPRC.

#### § 1202.4 Definitions.

For the purposes of this part, the term:

(a) *Access* means a transfer of a record, a copy of a record, or the information in a record to the subject individual, or the review of a record by the subject individual.

(b) *Agency* means any executive department, military department, Government corporation, Government-controlled corporation, or other establishment in the executive branch of the Government (including the Executive Office of the President), or any independent regulatory agency.

(c) *Defunct agency* means an agency that has ceased to exist, and has no successor in function.

(d) *Defunct agency records* means the records in a Privacy Act system of a defunct agency that are stored in a NARA records center.

(e) *Disclosure* means a transfer by any means of a record, a copy of a record, or the information contained in a record to a recipient other than the subject individual, or the review of a record by someone other than the subject individual.

(f) *Individual* means a citizen of the United States or an alien lawfully admitted for permanent residence.

(g) *Maintain* includes maintain, collect, use, or disseminate.

(h) *NARA Privacy Act Appeal Official* means the Deputy Archivist of the United States for appeals of denials of access to or amendment of records maintained in a system of records, except where the system manager is the Inspector General; then the term means the Archivist of the United States.

(i) *Record* means any item, collection, or grouping of information about an individual that is maintained by an agency, including, but not limited to, his or her education, financial transactions, medical history and criminal or employment history, and that contains his or her name or an identifying number, symbol, or other identifying particular assigned to the individual, such as a fingerprint, voiceprint, or photograph. For purposes of this part, “record” does not mean archival records that have been transferred to

## § 1202.6

the National Archives of the United States.

(j) *Routine use* means, with respect to the disclosure of a record, the use of that record for a purpose which is compatible with the purpose for which it was collected.

(k) *Solicitation* means a request by a NARA employee or contractor that an individual provide information about himself or herself.

(l) *Statistical record* means a record in a system of records maintained for statistical research or reporting purposes only and not used in whole or in part in making any determination about an identifiable individual, except as provided by 13 U.S.C. 8.

(m) *Subject individual* means the individual named or discussed in a record or the individual to whom a record otherwise pertains.

(n) *System manager* means the NARA employee who is responsible for the maintenance of a system of records and for the collection, use, and dissemination of information in that system of records.

(o) *System of records* means a group of records from which information is retrieved by the name of the individual or by some identifying number, symbol, or other identifier assigned to that individual.

### § 1202.6 Whom should I contact for Privacy Act matters at NARA?

Contact the NARA Privacy Act Officer, National Archives and Records Administration (NGC), Room 3110, 8601 Adelphi Road, College Park, MD 20740-6001, for guidance in making a Privacy Act request, or if you need assistance with an existing request. The Privacy Act Officer will refer you to the responsible system manager. Details about what to include in your Privacy Act request are discussed in Subpart C of this part.

### § 1202.8 How does NARA handle records that are in Government-wide Privacy Act systems?

Records in the custody of NARA in a Government-wide Privacy Act system are the primary responsibility of another agency, e.g., the Office of Personnel Management (OPM) or the Office of Government Ethics (OGE).

## 36 CFR Ch. XII (7-1-03 Edition)

These records are governed by the regulations established by that agency pursuant to the Privacy Act. NARA provides access using that agency's regulations.

### § 1202.10 Does NARA handle access to and disclosure of records of defunct agencies in the custody of NARA?

Yes, records of defunct agencies in the custody of NARA at a NARA record center are covered by the provisions of this part.

## Subpart B—Collecting Information

### § 1202.18 How does NARA collect information about individuals?

Any information that is used in making a determination about your rights, benefits, or privileges under NARA programs is collected directly from you—the subject individual—to the greatest extent possible.

### § 1202.20 What advisory information does NARA provide before collecting information from me?

(a) Before collecting information from you, NARA will advise you of:

- (1) The authority for collecting the information and whether providing the information is mandatory or voluntary;
- (2) The purpose for which the information will be used;
- (3) The routine uses of the information; and
- (4) The effect on you, if any, of not providing the information.

(b) NARA ensures that forms used to record the information that you provide are in compliance with the Privacy Act and this part.

### § 1202.22 Will NARA need my Social Security Number?

(a) Before a NARA employee or NARA contractor asks you to provide your social security number (SSN), he or she will ensure that the disclosure is required by Federal law or under a Federal law or regulation adopted before January 1, 1975.

(b) If you are asked to provide your SSN, the NARA employee or contractor must first inform you:

- (1) Whether the disclosure is mandatory or voluntary;



- (2) The statute or authority under which your SSN is solicited; and
- (3) How your SSN will be used.

**§ 1202.24 Will NARA ever request information about me from someone else?**

NARA will make every effort to gather information from you directly. When NARA solicits information about you from someone else, NARA will explain to that person the purpose for which the information will be used.

**§ 1202.26 Who will make sure that my record is accurate?**

The system manager ensures that all records used by NARA to make a determination about any individual are maintained with such accuracy, relevancy, timeliness, and completeness as is reasonably possible to ensure fairness to you.

**§ 1202.28 What rules do NARA employees follow in managing personal information?**

All NARA employees and contractors involved in the design, development, operation or maintenance of any system of records must review the provisions of the Privacy Act and the regulations in this part. NARA employees and contractors must conduct themselves in accordance with the rules of conduct concerning the protection of nonpublic information in the Standards of Ethical Conduct for Employees of the Executive Branch, 5 CFR 2635.703.

**§ 1202.30 How does NARA safeguard its systems of records?**

(a) The system manager ensures that appropriate administrative, technical, and physical safeguards are established to ensure the security and confidentiality of records. In order to protect against any threats or hazards to their security or loss of integrity, paper records are maintained in areas accessible only to authorized NARA personnel. Electronic records are protected in accordance with the Computer Security Act, OMB Circular A-11 requiring privacy analysis in reporting to OMB, and are accessed via passwords from terminals located in attended offices. After hours, buildings have secu-

rity guards and/or doors are secured and all entrances are monitored by electronic surveillance equipment.

(b) The system manager, at his/her discretion, may designate additional safeguards similar to or greater than those described in paragraph (a) of this section for unusually sensitive records.

(c) The system manager only permits access to and use of automated or manual personnel records to persons whose official duties require such access, or to you or to a representative designated by you.

**Subpart C—Individual Access to Records**

**§ 1202.40 How can I gain access to NARA records about myself?**

(a) If you wish to request access to information about yourself contained in a NARA Privacy Act system of records, you must notify the NARA Privacy Act Officer, National Archives and Records Administration, Rm. 3110, 8601 Adelphi Rd., College Park, MD 20740-6001. If you wish to allow another person to review or obtain a copy of your record, you must provide authorization for that person to obtain access as part of your request.

(b) Your request must be in writing and the letter and the envelope must be marked "Privacy Act Request." Your request letter must contain:

(1) The complete name and identifying number of the NARA system as published in the FEDERAL REGISTER;

(2) A brief description of the nature, time, place, and circumstances of your association with NARA;

(3) Any other information, which you believe, would help NARA to determine whether the information about you is included in the system of records;

(4) If you are authorizing another individual to have access to your records, the name of that person; and

(5) A Privacy Act certification of identity. When you make a request for access to records about yourself, you must verify your identity. You must sign your request and your signature must either be notarized or submitted by you under 28 U.S.C. 1746, a law that permits statements to be made under penalty of perjury as a substitute for notarization. While no specific form is

## § 1202.42

required, you may obtain a Certification of Identity form for this purpose from the NARA Privacy Act Officer. The following information is required:

- (i) Your full name;
  - (ii) An acknowledgment that you understand the criminal penalty in the Privacy Act for requesting or obtaining access to records under false pretenses (5 U.S.C. 552a(i)(3)); and
  - (iii) A declaration that your statement is true and correct under penalty of perjury (18 U.S.C. 1001).
- (c) The procedure for accessing an accounting of disclosure is identical to the procedure for access to a record as set forth in this section.

### § 1202.42 How are requests for access to medical records handled?

When NARA receives a request for access to medical records, if NARA believes that disclosure of medical and/or psychological information directly to you could have an adverse effect on you, you may be asked to designate in writing a physician or mental health professional to whom you would like the records to be disclosed, and disclosure that otherwise would be made to you will instead be made to the designated physician or mental health professional.

### § 1202.44 How long will it take for NARA to process my request?

- (a) NARA will acknowledge your request within 10 workdays of its receipt by NARA and if possible, will make the records available to you at that time. If NARA cannot make the records immediately available, the acknowledgment will indicate when the system manager will make the records available.
- (b) If NARA anticipates more than a 10 workday delay in making a record you requested available, NARA also will explain in the acknowledgment specific reasons for the delay.
- (c) If your request for access does not contain sufficient information to permit the system manager to locate the records, NARA will request additional information from you. NARA will have 10 workdays following receipt of the additional information in which to make the records available or to acknowledge receipt of the request and to

## 36 CFR Ch. XII (7-1-03 Edition)

indicate when the records will be available.

### § 1202.46 In what ways will NARA provide access?

(a) At your request, NARA will provide you, or a person authorized by you, a copy of the records by mail or by making the records available in person during normal business hours at the NARA facility where the records are located. If you are seeking access in person, the system manager will permit you to examine the original record, will provide you with a copy of the records, or both.

(b) When obtaining access to the records in person at a NARA facility, you must provide proof of identification either by producing at least one piece of identification bearing a name or signature and either a photograph or physical description (e.g., a driver's license or employee identification card) or by signing the Certification of Identity form described in § 1204.40 (b)(5). NARA reserves the right to ask you to produce additional pieces of identification to assure NARA of your identity. You will also be asked to sign an acknowledgement that you have been given access.

### § 1202.48 Will I have to pay for copies of records?

Yes. However NARA will waive fees for the first 100 pages copied or when the cost to collect the fee will exceed the amount collected. When a fee is charged, the charge per copy is \$0.20 per page if NARA makes the copy or \$0.15 per page if you make the copy on a NARA self-service copier. Fees for other reproduction processes are computed upon request.

### § 1202.50 Does NARA require prepayment of fees?

If the system manager determines that the estimated total fee is likely to exceed \$250, NARA will notify you that the estimated fee must be prepaid before you can have copies of the records. If the final fee is less than the amount you prepaid, NARA will refund the difference.

**§ 1202.52 How do I pay?**

You must pay by check or money order. Make your check or money order payable to the National Archives and Records Administration and send it to the NARA Privacy Act Officer, Room 3110, 8601 Adelphi Road, College Park, MD 20740-6001.

**§ 1202.54 On what grounds can NARA deny my Privacy Act request?**

(a) NARA can deny your Privacy Act request for records if the records are maintained in an exempt systems of records are described in subpart F of this part.

(b) A system manager may deny your request for access to your records only if:

(1) NARA has published rules in the FEDERAL REGISTER exempting the pertinent system of records from the access requirement; and

(2) The record is exempt from disclosure under the Freedom of Information Act (FOIA).

(c) Upon receipt of a request for access to a record which is contained within an exempt system of records, NARA will:

(1) Review the record to determine whether all or part of the record must be released to you in accordance with § 1202.40, notwithstanding the inclusion of the record within an exempt system of records; and

(2) Provide access to the record (or part of the record, if it is not fully releasable) in accordance with § 1202.46 or notify you that the request has been denied in whole or in part.

(d) If your request is denied in whole or in part, NARA's notice will include a statement specifying the applicable Privacy Act and FOIA exemptions and advising you of the right to appeal the decision as explained in § 1202.56.

**§ 1202.56 How do I appeal a denial of my Privacy Act request?**

(a) If you are denied access in whole or in part to records pertaining to yourself, you may file with NARA an appeal of that denial. Your appeal letter must be post marked no later than 35 calendar days after the date of the denial letter from NARA.

(1) Address appeals involving denial of access to Office of Inspector General

records to NARA Privacy Act Appeal Official (N), National Archives and Records Administration, Room 4200, 8601 Adelphi Road, College Park, MD 20740-6001.

(2) Address all other appeals to the NARA Privacy Act Appeal Official (ND), National Archives and Records Administration, Room 4200, 8601 Adelphi Road, College Park, MD 20740-6001.

(b) All appeals of denial of access to the NARA Privacy Act Appeal Official must be in writing. Mark both the envelope and the appeal "Privacy Act " Access Appeal."

**§ 1202.58 How are appeals processed?**

(a) Upon receipt of your appeal, the NARA Privacy Act Appeal Official will consult with the system manager, legal counsel, and such other officials as may be appropriate. If the NARA Privacy Act Appeal Official determines that the records you requested are not exempt from release, NARA grants you access and so notifies you.

(b) If the NARA Privacy Act Appeal Official determines that your appeal must be rejected, NARA will immediately notify you in writing of that determination. This decision is final and cannot be appealed further within NARA. NARA's notification to you will include:

(1) The reason for the rejection of the appeal; and

(2) Notice of your right to seek judicial review of NARA's final determination, as described in 36 CFR 1202.84.

(c) NARA will make its final determination no later than 30 workdays from the date on which NARA receives your appeal. NARA may extend this time limit by notifying you in writing before the expiration of the 30 workdays. This notification will include an explanation of the reasons for the time extension.

**Subpart D—Disclosure of Records****§ 1202.60 When does NARA disclose a record in a Privacy Act system of records?**

NARA will not disclose any records in a Privacy Act system of records to any person or to another agency without the express written consent of the

## § 1202.62

subject individual unless the disclosure is:

(a) To NARA employees who have a need for the information in the official performance of their duties;

(b) Required by the provisions of the Freedom of Information Act, as amended;

(c) For a routine use that has been published in a notice in the FEDERAL REGISTER;

(d) To the Bureau of Census for purposes of planning or carrying out a census or survey or related activity pursuant to title 13 U.S.C.;

(e) To a person who has provided NARA with advance adequate written assurance as specified in §1202.62(a) that the record will be used solely as a statistical research or reporting record. (Personal identifying information is deleted from the record released for statistical purposes. The system manager ensures that the identity of the individual cannot reasonably be deduced by combining various statistical records.)

(f) To the National Archives of the United States as a record which has sufficient historical or other value to warrant its continued preservation by the United States Government or for evaluation by the Archivist or the designee of the Archivist to determine whether the record has such value;

(g) To another agency or any governmental jurisdiction within or under the control of the United States for a civil or criminal law enforcement activity if the activity is authorized by law, and if the head of the agency or his or her other designated representative has made a written request to NARA specifying the particular portion desired and the law enforcement activity for which the record is sought;

(h) To a person showing compelling circumstances affecting the health or safety of an individual, and not necessarily the individual to whom the record pertains. A disclosure of this nature is followed by a notification to the last known address of the subject individual;

(i) To either House of Congress or to a committee or subcommittee (joint or of either House), in the course of the performance of official legislative activities;

## 36 CFR Ch. XII (7-1-03 Edition)

(j) To the Comptroller General or any of his authorized representatives in the course of the performance of the duties of the General Accounting Office;

(k) Pursuant to the order of a court of competent jurisdiction; or

(l) To a consumer reporting agency in accordance with 31 U.S.C. 3711(e).

### § 1202.62 What are the procedures for disclosure of records to a third party?

(a) To obtain access to records about a person other than yourself, address the request to the NARA Privacy Act Officer, National Archives and Records Administration, Room 3110, 8601 Adelphi Rd., College Park, MD 20740-6001. If you are requesting access for statistical research as described in §1202.60(e), you must submit a written statement that includes as a minimum:

(1) A statement of the purpose for requesting the records; and

(2) Certification that the records will be used only for statistical purposes.

(b) NARA will acknowledge your request within 10 workdays and will make a decision within 30 workdays, unless NARA notifies you that the time limit must be extended for good cause.

(c) Upon receipt of your request, NARA will verify your right to obtain access to documents pursuant to §1202.60. Upon verification, the system manager will make the requested records available to you.

(d) If NARA determines that the disclosure is not permitted under §1202.60, the system manager will deny your request in writing. NARA will inform you of the right to submit a request for review of the denial and a final determination to the appropriate NARA Privacy Act Appeal Officer.

### § 1202.64 How do I appeal a denial of disclosure?

(a) Your request for a review of the denial of disclosure to records maintained by the Office of the Inspector General must be addressed to the NARA Privacy Act Appeal Officer (N), National Archives and Records Administration, Room 4200, 8601 Adelphi Rd., College Park, MD 20740-6001.

(b) Requests for a review of a denial of disclosure to all other NARA records

must be addressed to the NARA Privacy Act Appeal Officer (ND), National Archives and Records Administration, Room 4200, 8601 Adelphi Rd., College Park, MD 20740-6001.

**§ 1202.66 How does NARA keep account of disclosures?**

(a) Except for disclosures made to NARA employees in the course of the performance of their duties or when required by the Freedom of Information Act (see §1202.60(a) and (b)), NARA keeps an accurate accounting of each disclosure and retains it for 5 years after the disclosure or for the life of the record, whichever is longer. The accounting includes the:

- (1) Date of disclosure;
- (2) Nature, and purpose of each disclosure; and
- (3) Name and address of the person or agency to which the disclosure is made.

(b) The system manager also maintains with the accounting of disclosures:

- (1) A full statement of the justification for the disclosures;
- (2) All documentation surrounding disclosure of a record for statistical or law enforcement purposes; and
- (3) Evidence of written consent by the subject individual to a disclosure, if applicable.

(c) Except for the accounting of disclosures made for a law enforcement activity (see §1202.60(g)) or of disclosures made from exempt systems (see subpart F of this part), the accounting of disclosures will be made available to the subject individual upon request. Procedures for requesting access to the accounting of disclosures are in subpart C.

**Subpart E—Request To Amend Records**

**§ 1202.70 Whom should I contact at NARA to amend records about myself?**

If you believe that a record that NARA maintains about you is not accurate, timely, relevant or complete, you may request that the record be amended. Write to the NARA Privacy Act Officer, Room 3110, 8601 Adelphi Rd., College Park, MD 20740-6001. Employees of NARA who desire to amend

their personnel records should write to the Director, Human Resources Services Division. You should include as much information, documentation, or other evidence as needed to support your request to amend the pertinent record. Mark both the envelop and the letter with the phrase “Privacy Act—Request To Amend Record.”

**§ 1202.72 How does NARA handle requests to amend records?**

(a) NARA will acknowledge receipt of a request to amend a record within 10 workdays. If possible, the acknowledgment will include the system manager’s determination either to amend the record or to deny your request to amend as provided in §1202.76.

(b) When reviewing a record in response to your request to amend, the system manager will assess the accuracy, relevance, timeliness, and completeness of the existing record in light of your proposed amendment to determine if your request to amend is justified. If you request the deletion of information, the system manager also will review your request and the existing record to determine whether the information is relevant and necessary to accomplish NARA’s purpose, as required by law or Executive order.

**§ 1202.74 How will I know if NARA approved my amendment request?**

If NARA approves your amendment request, the system manager will promptly make the necessary amendment to the record and will send a copy of the amended record to you. NARA will also advise all previous recipients of the record, using the accounting of disclosures, that an amendment has been made and give the substance of the amendment. Where practicable, NARA will also send a copy of the amended record to previous recipients.

**§ 1202.76 Can NARA deny my request for amendment?**

If the system manager denies your request to amend or determines that the record should be amended in a manner other than that requested by you, NARA will advise you in writing of the decision. The denial letter will state:

## § 1202.78

- (a) The reasons for the denial of your amendment request;
- (b) Proposed alternative amendments, if appropriate;
- (c) Your right to appeal the denial; and
- (d) The procedures for appealing the denial.

### § 1202.78 How do I accept an alternative amendment?

If your request to amend a record is denied and NARA suggested alternative amendments, and you agree to those alternative amendments, you must notify the Privacy Act Officer who will then make the necessary amendments in accordance with § 1202.74.

### § 1202.80 How do I appeal the denial of a request to amend a record?

(a) If you disagree with a denial of your request to amend a record, you can file an appeal of that denial.

(1) Address your appeal of the denial to amend records signed by a system manager other than the Inspector General, to the NARA Privacy Act Appeal Official (ND), Room 3110, 8601 Adelphi Road, College Park, MD, 20740-6001.

(2) Address the appeal of the denial to amend records signed by the Inspector General to the NARA Privacy Act Appeal Official (N), Room 3110, 8601 Adelphi Road, College Park, MD, 20740-6001.

(3) For current NARA employees if the denial to amend concerns a record maintained in the employee's Official Personnel Folder or in another Government-wide system maintained by NARA on behalf of another agency, NARA will provide the employee with name and address of the appropriate appeal official in that agency.

(b) Appeals to NARA must be in writing and must be postmarked no later than 35 calendar days from the date of the NARA denial of a request to amend. Your appeal letter and envelope must be marked "Privacy Act—Appeal".

(c) Upon receipt of an appeal, the NARA Privacy Act Appeal Official will consult with the system manager, legal counsel, and such other officials as may be appropriate. If the appeal official determines that the record should

## 36 CFR Ch. XII (7-1-03 Edition)

be amended, he or she will instruct the system manager to amend the record in accordance with § 1202.74 and will notify you of that action.

(d) If, after consulting with officials specified in paragraph (c) of this section, the NARA Privacy Act Appeal Official determines that your appeal should be rejected, the NARA Privacy Act Appeal Official will notify you in writing of that determination. This notice serves as NARA's final determination on your request to amend a record. The letter to you will include:

(1) The reason for the rejection of your appeal;

(2) Proposed alternative amendments, if appropriate, which you may accept (see 36 CFR 1202.78 for the procedure);

(3) Notice of your right to file a Statement of Disagreement for distribution in accordance with § 1202.82; and

(4) Notice of your right to seek judicial review of the NARA final determination, as provided in § 1202.84.

(e) The NARA final determination will be made no later than 30 workdays from the date on which the appeal is received by the NARA Privacy Act Appeal Official. In extraordinary circumstances, the NARA Privacy Act Appeal Official may extend this time limit by notifying you in writing before the expiration of the 30 workdays. The notification will include a justification for the extension of time.

### § 1202.82 How do I file a Statement of Disagreement?

If you receive a NARA final determination denying your request to amend a record, you may file a Statement of Disagreement with the appropriate system manager. The Statement of Disagreement must include an explanation of why you believe the record to be inaccurate, irrelevant, untimely, or incomplete. The system manager will maintain your Statement of Disagreement in conjunction with the pertinent record. The System Manager will send a copy of the Statement of Disagreement to any person or agency to whom the record has been disclosed, only if the disclosure was subject to the accounting requirements of § 1202.60.

**§ 1202.84 Can I seek judicial review?**

Yes, within 2 years of receipt of a NARA final determination as provided in § 1202.54 or § 1202.80, you may seek judicial review of that determination. You may file a civil action in the Federal District Court:

- (a) In which you reside or have a principal place of business;
- (b) In which the NARA records are located; or
- (c) In the District of Columbia.

**Subpart F—Exemptions****§ 1202.90 What NARA systems of records are exempt from release under the National Security Exemption of the Privacy Act?**

(a) The Investigative Case Files of the Inspector General (NARA-23) and the Personnel Security Case Files (NARA-24) systems of records are eligible for exemption under 5 U.S.C. 552a(k)(1) because the records in these systems:

(1) Contain information specifically authorized under criteria established by an Executive Order to be kept secret in the interest of national defense or foreign policy and

(2) Are in fact properly classified pursuant to such Executive Order.

(b) The systems described in paragraph (a) are exempt from 5 U.S.C. 552a (c)(3), (d), (e)(1), and (e)(4)(G) and (H). Exemptions from the particular subsections are justified for the following reasons:

(1) From subsection (c)(3) because accounting for each disclosure could result in the release of properly classified information which would compromise the national defense or disrupt foreign policy.

(2) From the access and amendment provisions of subsection (d) because access to the records in these systems of records could result in the release of properly classified information which would compromise the national defense or disrupt foreign policy. Amendment of either of these series of records would interfere with ongoing investigations and law enforcement or national security activities and impose an impossible administrative burden by requiring investigations to be continuously reinvestigated.

(3) From subsection (e)(1) because verification of the accuracy of all information to the records could result in the release of properly classified information which would compromise the national defense or disrupt foreign policy.

(4) From subsection (e)(4)(G) and (H) because these systems are exempt from the access and amendment provisions of subsection (d), pursuant to subsection (k)(1) of the Privacy Act.

**§ 1202.92 What NARA systems of records are exempt from release under the Law Enforcement Exemption of the Privacy Act?**

(a) The Investigative Files of the Inspector General (NARA-23) system of records is eligible for exemption under 5 U.S.C. 552a(k)(2) because this record system contains investigatory material of actual, potential or alleged criminal, civil or administrative violations, compiled for law enforcement purposes other than within the scope of subsection (j)(2) of 5 USC 552a. If you are denied any right, privilege or benefit that you would otherwise be entitled by Federal law, or for which you would otherwise be eligible, as a result of the record, NARA will make the record available to you, except for any information in the record that would disclose the identity of a confidential source as described in 5 U.S.C. 552a(k)(2).

(b) The system described in paragraph (a) of this section is exempt from 5 U.S.C. 552a (c)(3), (d), (e)(1) and (e)(4)(G) and (H), and (f). Exemptions from the particular subsections are justified for the following reasons:

(1) From subsection (c)(3) because release of disclosure accounting could alert the subject of an investigation about the alleged violations, to the existence of the investigation and to the fact that they are being investigated by the Office of Inspector General (OIG) or another agency. Release of such information could provide significant information concerning the nature of the investigation, resulting in the tampering or destruction of evidence, influencing of witnesses, danger to individuals involved, and other activities that could impede or compromise the investigation.

§ 1202.94

36 CFR Ch. XII (7-1-03 Edition)

(2) From the access and amendment provisions of subsection (d) because access to the records contained in this system of records could inform the subject of an investigation of an actual or potential criminal, civil, or administrative violation, of the existence of that investigation; of the nature and scope of the information and evidence obtained as to his/her activities; of the identity of confidential sources, witnesses, and law enforcement personnel; and of information that may enable the subject to avoid detection or apprehension. These factors would present a serious impediment to effective law enforcement where they prevent the successful completion of the investigation, endanger the physical safety of confidential sources, witnesses, and law enforcement personnel, and/or lead to the improper influencing of witnesses, the destruction of evidence, or the fabrication of testimony. In addition, granting access to such information could disclose security-sensitive or confidential business information or information that would constitute an unwarranted invasion of the personal privacy of third parties. The amendment of these records could allow the subject to avoid detection or apprehension and interfere with ongoing investigations and law enforcement activities.

(3) From subsection (e)(1) because the application of this provision could impair investigations and interfere with the law enforcement responsibilities of the OIG or another agency for the following reasons:

(i) It is not possible to detect relevance or need for specific information in the early stages of an investigation, case or matter. After the information is evaluated, relevance and necessity may be established.

(ii) During an investigation, the OIG may obtain information about other actual or potential criminal, civil or administrative violations, including those outside the scope of its jurisdiction. The OIG should retain this information, as it may aid in establishing patterns of inappropriate activity, and can provide valuable leads for Federal and other law enforcement agencies.

(iii) In interviewing individuals or obtaining other forms of evidence dur-

ing an investigation, information may be supplied to an investigator, which relates to matters incidental to the primary purpose of the investigation but which may relate also to matters under the investigative jurisdiction of another agency. Such information cannot readily be segregated.

(iv) From subsection (e)(4)(G) and (H) because this system is exempt from the access and amendment provisions of subsection (d), pursuant to subsection (k)(2) of the Privacy Act.

(v) From subsection (f) because this system is exempt from the access and amendment provisions of subsection (d), pursuant to subsection (k)(2) of the Privacy Act.

**§ 1202.94 What NARA systems of records are exempt from release under the Investigatory Information Material exemption of the Privacy Act?**

(a) The Personnel Security Case Files (NARA-24) system of records is eligible for exemption under 5 U.S.C. 552a(k)(5) because it contains investigatory material compiled solely for the purpose of determining suitability, eligibility, or qualifications for federal employment or access to classified information. The only information exempt under this provision is that which would disclose the identity of a confidential source described in 5 U.S.C. 552a(k)(2).

(b) The system of records described in paragraph (a) of this section is exempt from 5 U.S.C. 552a(d)(1). Exemption from the particular subsection is justified as access to records in the system would reveal the identity(ies) of the source(s) of information collected in the course of a background investigation.

**PART 1206—NATIONAL HISTORICAL PUBLICATIONS AND RECORDS COMMISSION**

**Subpart A—General**

- Sec.
- 1206.1 How do you use pronouns in this part?
- 1206.2 What does this part cover?
- 1206.3 What terms have you defined?
- 1206.4 What is the purpose of the Commission?



## National Archives and Records Administration

## § 1206.3

- 1206.5 Who is on the Commission?
- 1206.6 How do you organize the grant program?
- 1206.8 How do you operate the grant program?

### Subpart B—Publications Grants

- 1206.10 What are the scope and purpose of publications grants?
- 1206.12 What type of proposal is eligible for a publications grant?
- 1206.14 What type of proposal is ineligible for a publications grant?
- 1206.16 What are my responsibilities once I have received a publications grant?
- 1206.18 What is a subvention grant, and am I eligible for one?

### Subpart C—Records Grants

- 1206.20 What are the scope and purpose of records grants?
- 1206.22 What type of proposal is eligible for a records grant?
- 1206.24 What type of proposal is ineligible for a records grant?

### Subpart D—State Historical Records Advisory Boards

- 1206.30 What is a State historical records advisory board?
- 1206.32 What is a State historical records coordinator?
- 1206.34 What are the duties of the deputy State historical records coordinator?

### Subpart E—Applying for NHPRC Grants

- 1206.40 What types of funding and cost sharing arrangements does the Commission make?
- 1206.42 Does the Commission ever place conditions on its grants?
- 1206.44 Who may apply for NHPRC grants?
- 1206.46 When are applications due?
- 1206.48 How do I apply for a grant?
- 1206.50 What must I provide as a formal grant application?
- 1206.52 Who reviews and evaluates grant proposals?
- 1206.54 What formal notification will I receive and will it contain other information?

### Subpart F—Grant Administration

- 1206.60 Who is responsible for administration of NHPRC grants?
- 1206.62 Where can I find the regulatory requirements that apply to NHPRC grants?
- 1206.64 When do I need prior written approval for changes in the grant project?
- 1206.66 How do I obtain written approval for changes in my grant project?
- 1206.68 Are there any changes for which I do not need approval?

- 1206.70 What reports am I required to make?
- 1206.72 What is the format and content of the financial report?
- 1206.74 What is the format and content of the narrative report?
- 1206.76 What additional materials must I submit with the final narrative report?
- 1206.78 Does the NHPRC have any liability under a grant?
- 1206.80 Must I acknowledge NHPRC grant support?

AUTHORITY: 44 U.S.C. 2104(a); 44 U.S.C. 2501-2506.

SOURCE: 67 FR 42494, June 24, 2002, unless otherwise noted.

### Subpart A—General

#### § 1206.1 How do you use pronouns in this part?

In the section heading questions we use the pronouns “I” and “my” to refer to the reader, and “you” to refer to the National Historical Publications and Records Commission (“NHPRC” or “the Commission”) as if you, the reader, were asking us, the Commission, these questions. In the section body, we use the pronouns “you” and “yours” to refer to the reader and “we” and “our” to refer to the Commission as we answer the questions posed.

#### § 1206.2 What does this part cover?

This part prescribes the procedures and rules governing the operation of the grant program of the National Historical Publications and Records Commission.

#### § 1206.3 What terms have you defined?

(a) The term *Commission* means the National Historical Publications and Records Commission or the Chairman of the Commission or the Executive Director of the Commission, acting on the Commission’s behalf.

(b) The term *historical records* means record material having permanent or enduring value regardless of physical form or characteristics, including, but not limited to, manuscripts, archives, personal papers, official records, maps, audiovisual materials, and electronic files.

(c) In §§ 1206.30 and 1206.32, the term *State* means all 50 States of the Union, plus the District of Columbia, Puerto Rico, the U.S. Virgin Islands, Guam,

#### § 1206.4

American Samoa, Northern Mariana Islands, and the Trust Territories of the Pacific.

(d) The term *State projects* means records projects involving records or activities directed by organizations operating within one State. Records or activities of such projects will typically be under the administrative control of the organization applying for the grant. The records or activities need not relate to the history of the State.

(e) The term *cost sharing* means the financial contribution the applicant pledges to the cost of a project. Cost sharing can include both direct and indirect expenses, in-kind contributions, third-party contributions, and any income earned directly by the project (e.g., registration fees).

(f) The term *direct costs* means expenses that are attributable directly to the cost of a project, such as salaries, project supplies, travel expenses, and equipment rented or purchased for the project.

(g) The term *indirect costs* means costs incurred for common or joint objectives and therefore not attributable to a specific project or activity. Typically, indirect costs include items such as overhead for facilities maintenance and accounting services.

(h) The term *board* refers to a State historical records advisory board.

(i) The term *coordinator* means the coordinator of a State historical records advisory board.

#### § 1206.4 What is the purpose of the Commission?

The National Historical Publications and Records Commission, a statutory body affiliated with the National Archives and Records Administration, supports a wide range of activities to preserve, publish, and encourage the use of primary documentary sources. These sources can be in every medium, created with tools ranging from quill pen to computer, relating to the history of the United States. Through our grant programs, training programs, and special projects, we offer advice and assistance to non-Federal, non-profit organizations, agencies, and institutions, including Federally-acknowledged or State-recognized Native

#### 36 CFR Ch. XII (7-1-03 Edition)

American tribes or groups, and to individuals committed to the preservation, publication, and use of United States documentary resources.

#### § 1206.5 Who is on the Commission?

Established by Congress in 1934, the Commission is a 15-member body, chaired by the Archivist of the United States and comprised of representatives of the three branches of the Federal Government and of professional associations of archivists, historians, documentary editors, and records administrators.

#### § 1206.6 How do you organize the grant program?

We primarily offer grants through a program supporting publications projects (Subpart B) and records projects (Subpart C). We also offer fellowships for individuals in archival administration and documentary editing, as well as an annual institute for the editing of historical documents.

#### § 1206.8 How do you operate the grant program?

(a) The Executive Director and staff manage the program under guidance from the Commission and the immediate administrative direction of its chairman, the Archivist of the United States.

(b) To assure fair treatment of every application, all members of the Commission and its staff follow conflict-of-interest rules.

(c) The purpose and work plan of all NHPRC funded grant projects must be in accord with current NHPRC guidelines and funding can be released only upon the recommendation of the Commission to the Archivist.

#### Subpart B—Publications Grants

#### § 1206.10 What are the scope and purpose of publications grants?

Publications projects are intended to make documentary source material that is important to the study and understanding of United States history widely available. Historical records must have national value and interest.

**§ 1206.12 What type of proposal is eligible for a publications grant?**

We provide support for:

(a) Documentary editing projects consisting of either the papers of a United States leader in a significant phase of life in the United States or historical records relating to outstanding events or topics or themes of national significance in United States history. These projects involve collecting, compiling, transcribing, editing, annotating, and publishing, either selectively or comprehensively, the papers or historical records.

(b) Fellowships in historical documentary editing at editorial projects supported by the NHPRC.

(c) Subvention grants to nonprofit presses to help defray publication costs of NHPRC-supported or endorsed editions.

**§ 1206.14 What type of proposal is ineligible for a publications grant?**

We do not support:

(a) Historical research apart from the editing of documentary publications; or

(b) Documentary editing projects to publish the papers of someone who has been deceased for fewer than ten years.

**§ 1206.16 What are my responsibilities once I have received a publications grant?**

(a) *Printed publications.*

(1) *With no subvention grant.* You, the project director, must send three copies of each book publication to: National Historical Publications and Records Commission (NHPRC), National Archives and Records Administration, 700 Pennsylvania Avenue, NW, Washington, DC 20408-0001.

(2) *With subvention grant.* You, the publisher, must submit five copies of each book publication to the NHPRC at the address in paragraph (a)(1) of this section and ten copies to the project director or editor. The project director need not provide any copies to the NHPRC. (See § 1206.18.)

(b) *Microform publications.* For microform projects, you, the grantee, must make positive micrographics and all finding aids available to institutions, scholars, or students through interlibrary loan and for purchase. You

must also send three complimentary copies of the microform guides and indexes to the NHPRC at the address in paragraph (a)(1) of this section.

(c) *Electronic documentary publications.* If you publish a documentary edition in electronic form, you must produce a copy of the edition in an archivally-recognized format for long-term preservation.

**§ 1206.18 What is a subvention grant, and am I eligible for one?**

(a) A subvention grant is a subsidy of printing costs.

(b) We use subvention grants to encourage the widest possible distribution of NHPRC-supported and endorsed documentary editions and the highest archival permanence standards of paper, printing, and binding.

(c) The Commission considers grant applications from nonprofit presses for the subvention of part of the costs of manufacturing and distributing volumes that we have funded or formally endorsed.

(d) You, the publisher, must send five complimentary copies to NHPRC, and ten complimentary copies to the project director or editor for each published volume for which we gave you a subvention grant.

**Subpart C—Records Grants****§ 1206.20 What are the scope and purpose of records grants?**

Records projects are supported by the National Historical Publications and Records Commission to preserve and make available State government, local government, and non-government historical records of national and State significance for the purpose of furthering an understanding and appreciation of United States history.

**§ 1206.22 What type of proposal is eligible for a records grant?**

We provide support for:

(a) Locating, preserving and making available records of State, local, and other governmental units; and other private collections maintained in non-Federal, non-profit repositories and special collections relating to particular fields of study, including the arts, business, education, ethnic and

**§ 1206.24**

minority groups, immigration, labor, politics, professional services, religion, science, urban affairs, and women;

(b) Advancing the state of the art in archival and records management; and in the long-term maintenance and easy access of authentic electronic records;

(c) Promoting cooperative efforts among institutions and organizations in archival and records management;

(d) Improving the knowledge, performance, and professional skills of those who work with historical records; and

(e) Fellowships in archival administration, a training program in various aspects of archival management held at host institutions.

**§ 1206.24 What type of proposal is ineligible for a records grant?**

We do not support proposals:

(a) To construct, renovate, furnish, or purchase a building or land;

(b) To purchase manuscripts or other historical records;

(c) To conserve archaeological artifacts, museum objects, or works of art;

(d) To exhibit archaeological artifacts, museum objects, works of art, and documents;

(e) To acquire, preserve, or describe books, periodicals, or other library materials;

(f) To acquire, preserve, or describe art objects, sheet music, or other works primarily of value as works of art or entertainment;

(g) To support celebrations, reenactments, and other observations of historical events.

(h) To conduct a records project centered on the papers of an appointed or elected public official who remains in major office, or is politically active, or the majority of whose papers have not yet been accessioned into a repository;

(i) To process historical records, most of which will be closed to researchers for more than five years, or not be accessible to all users on equal terms, or will be in a repository that denies public access;

(j) To conduct an arrangement, description, or preservation project in which the pertinent historical records are privately owned or deposited in an institution subject to withdrawal upon

**36 CFR Ch. XII (7-1-03 Edition)**

demand for reasons other than requirements of law; and

(k) To conduct an arrangement, description, or preservation project involving Federal government records that are:

(1) In the custody of the National Archives and Records Administration (NARA) or an archives officially affiliated with NARA;

(2) In the custody of another Federal agency; or

(3) Deposited in a non-Federal institution without an agreement authorized by NARA.

**Subpart D—State Historical Records Advisory Boards**

**§ 1206.30 What is a State historical records advisory board?**

(a) Each State actively participating in the NHPRC records program must adopt an appointment process and appoint a State historical records advisory board (the board) consisting of at least seven members, including the State historical records coordinator (see § 1206.32), who chairs the board, unless otherwise specified in State statute or regulation. The board coordinator must provide the Commission with a description of the appointment process. A majority of the members should have recognizable experience in the administration of government records, manuscripts, or archives. The board should be as broadly representative as possible of the public and private archives, records offices, and research institutions and organizations in the State. Board members will not be deemed to be officials or employees of the Federal Government and will receive no Federal compensation for their service on the board. They are appointed for three years. They may be re-appointed to serve additional terms. Preferably their terms should be staggered so that one-third of the board is newly appointed or re-appointed each year. If the board is not established in State law, members may continue to serve until replacements are appointed. The board may adopt standards for attendance and may declare membership positions open if those standards are

not met. The Board should adopt a conflict-of-interest policy, unless otherwise provided for in State statute or regulation.

(b) The board is the central advisory body for historical records planning and for Commission-funded records projects carried out within the State. The board helps historical records repositories and other information agencies coordinate activities within the State. The board reviews State records grant proposals for State projects as defined in the NHPRC guidelines and makes recommendations to the Commission. The board also engages in planning activities by developing, revising, and submitting to the Commission priorities for State historical records projects following the NHPRC guidelines. The board may also provide various other services. For example, it may sponsor and publish surveys of the conditions and needs of historical records in the State; solicit or develop proposals for projects to be carried out in the State with NHPRC grants or re-grants; promote an understanding of the role and value of historical records; and review the operation and progress of projects in the State financed by NHPRC grants.

(c) The NHPRC will not consider a grant proposal from a State government agency until a board is appointed and all appointments are current. If an active board is not in place within a State, local governments, nonprofit organizations or institutions, and individuals within that state may apply directly to the Commission for support.

**§ 1206.32 What is a State historical records coordinator?**

(a) *Appointment.* In order to actively participate in the NHPRC records program, your governor must appoint a State historical records coordinator (coordinator), the full-time professional official in charge of the State archival program or agency, unless otherwise specified in state statute or regulation. If your State has another State government historical agency or agencies with archival and/or records responsibilities, the official(s) in

charge of at least one of these must be a member of the State historical records advisory board (board).

(b) *Duties.* The coordinator is appointed to a minimum four-year term, but may continue to serve until replaced by the governor or until resignation. The coordinator will be the central coordinating officer for the historical records grant program in the State and should serve as chair of the board unless otherwise specified in the State statute or regulation. The coordinator is not deemed to be an official or employee of the Federal Government and will receive no Federal compensation for such service. The "Manual of Suggested Practices for State Historical Records Coordinators and State Historical Records Advisory Boards" which is available from the Commission and from State historical records coordinators, provides further information on the role of the coordinator. For a copy, write to NHPRC, National Archives and Records Administration, 700 Pennsylvania Avenue NW, Washington, DC 20408-0001, or contact us by e-mail at [nhprc@nara.gov](mailto:nhprc@nara.gov).

(c) *Replacement.* In the event of the resignation of the coordinator or other inability to serve, a deputy coordinator, if one has been designated, will serve as acting coordinator until the governor makes an appointment. In the absence of a deputy coordinator, the NHPRC will recognize an acting coordinator, selected by the State board, who will serve until the governor appoints a coordinator in order to conduct the necessary business of the board.

**§ 1206.34 What are the duties of the deputy State historical records coordinator?**

The governor or coordinator may designate a deputy State historical records coordinator to assist in carrying out the duties and responsibilities of the coordinator and to serve as an acting coordinator at the coordinator's direction or upon the coordinator's resignation or other inability to serve.

### Subpart E—Applying for NHPRC Grants

#### § 1206.40 What types of funding and cost sharing arrangements does the Commission make?

(a) *Types of grants.* (1) *Matching grant.* A matching grant is a way to demonstrate shared Federal/non-Federal support for projects. We will only match funds raised from non-Federal sources, either monies provided by the applicant's own institution specifically for the project or from a non-Federal third-party source.

(2) *Outright grant.* Outright grants are those awards we make without any matching component.

(b) *Cost sharing arrangements.* (1) For publications projects that first received NHPRC funding prior to 1992, the Commission will supply as much as 75 percent of the direct costs.

(2) For publications projects funded after 1992, the Commission will provide no more than 50 percent of direct costs. We will give preference to projects for which the sponsoring institution bears at least 25 percent of the direct costs. For short-term (i.e., 3 years or less) publications projects, we will give preference to applicants that provide at least 50 percent of the project's total direct and indirect costs.

(3) For records projects, the Commission will give preference to projects in which the applicants provide at least 50 percent of the project's total direct and indirect costs.

(4) We prefer the applicant cover indirect costs through cost sharing.

#### § 1206.42 Does the Commission ever place conditions on its grants?

In making its decisions on grants, the Commission may place certain conditions on its grants. We describe those possible conditions in the booklet *Grant Guidelines: How to Apply for NHPRC Grants, How to Administer NHPRC Grants*. For a copy, write to NHPRC, National Archives and Records Administration, 700 Pennsylvania Avenue NW, Washington, DC 20408-0001, or contact us by e-mail at [nhprc@nara.gov](mailto:nhprc@nara.gov).

#### § 1206.44 Who may apply for NHPRC grants?

The Commission will consider applications from State and local government agencies (Federal agencies are *not* eligible to apply), U.S. non-profit organizations and institutions, including institutions of higher education, Federally acknowledged or state-recognized Native American tribes or groups, United States citizens applying as individuals rather than for an organization, and State historical records advisory boards. Most NHPRC grants to individuals are awarded under its fellowship programs. In general, we prefer projects operating within a host institution.

#### § 1206.46 When are applications due?

The Commission generally meets twice a year, and we consider grant proposals during our meetings. For current application deadlines contact the NHPRC staff or your State historical records coordinators (for records grant proposals). Some State boards have established pre-submission review deadlines for records proposals; further information is available from your State coordinator(s). We will publish deadlines once a year in the FEDERAL REGISTER. All proposals must be post-marked by those deadlines.

#### § 1206.48 How do I apply for a grant?

(a) *Contact the NHPRC staff.* We encourage you to discuss your proposal through correspondence, by phone, or in person with Commission staff and/or, in the case of records proposals, with the appropriate State historical records coordinator before you submit the proposal and at all stages of your proposal's development.

(b) *Contact your State Historical Records Advisory Board.*

(1) Contact is not necessary if:

(i) Your proposal is for documentary editing and publication subvention projects;

(ii) You are a Native American applicant; or

(iii) Your project will largely take place in more than one state.

(2) Staff contacts and a list of State historical records coordinators may be found on our Web site at <http://www.nara.gov/nhprc>.

**National Archives and Records Administration**

**§ 1206.52**

**§ 1206.50 What must I provide as a formal grant application?**

You must submit the following materials as part of your grant application:

(a) *Application forms.* You can obtain copies of the following application forms from the Commission:

If you are an applicant for . . .	Then you must submit . . .
(1) NHPRC publication and records grants .....	"Application for Federal Assistance" (Standard Form 424) and "Budget Form" (NA Form 17001; OMB Control Number 3095-0004);
(2) Subvention grants .....	NHPRC subvention grant application (OMB Control Number 3095-0021), "Application for Federal Assistance" (Standard Form 424) and "Budget Form" (NA Form 17001);
(3) Archival or historical documentary editing fellowship host institutions.	NHPRC "Application for Host Institutions of Archival Administration or Historical Documentary Editing Fellowships" (OMB Control Number 3095-0015)
(4) NHPRC-sponsored fellowships .....	"Application for Archival Administration or Historical Documentary Editing Fellowships" (OMB Control Number 3095-0014);
(5) NHPRC-sponsored editing institute .....	"Application for Attendance at the Institute for the Editing of Historical Documents" (OMB Control Number 3095-0012).

(b) *Assurances and certifications.* You must submit the following assurances and certifications, signed by an authorized representative of your institution, or if you are an individual applicant, by you:

- (1) "Assurances—NonBConstruction Programs" (Standard Form 424B).
- (2) "Certification Regarding Lobbying; Debarment, Suspension and Other Responsibility Matters; and Drug-free Workplace Requirements."

(c) *Project summary.* You must submit a project summary. A description of the project summary is found in the booklet *Grant Guidelines: How to Apply for NHPRC Grants, How to Administer NHPRC Grants* that is available from the NHPRC and from State historical records coordinators.

(d) *List of performance objectives.* You must list in the proposal from four to seven quantifiable objectives by which the project can be evaluated following the submission of the final report and the closing of the grant. NHPRC evaluates the project to determine whether it produces the results promised in grant applications.

(e) *Submission requirements.* Send the original, signed copy of your application to the NHPRC, National Archives and Records Administration, 700 Pennsylvania Avenue, NW, Washington, DC 20408-0001. Your properly completed application and any materials you send with it (such as pamphlets and photographic prints) will not be returned to you. Additional copies must be sent as follows:

If you are applying for . . .	Then you must send . . .
(1) A documentary editing project that has previously been supported by the Commission.	Two additional copies to the NHPRC;
(2) A subvention grant .....	Two additional copies to the NHPRC;
(3) A new documentary editing project .....	Two additional copies to the NHPRC;
(4) A records grant and you are a Native American applicant ...	Two additional copies to the NHPRC;
(5) A records grant that is being done in a state where there is a State historical records advisory board.	One additional copy to the NHPRC and one copy to the State historical records coordinator. In order to help facilitate the review process, however, it is recommended that applicants send a copy for each member of the state board;
(6) A records grant whose work will take place in more than one State.	Two additional copies to the NHPRC.

**§ 1206.52 Who reviews and evaluates grant proposals?**

(a) *State boards.* State historical records advisory boards evaluate records proposals on technical merits as well as on their relation to State-

plan priorities. The board can return proposals it finds inappropriate or incomplete, with recommendations for revision, on which we will not act unless the applicant submits a revision for consideration in a later cycle. The

## § 1206.54

Board may also recommend that the Commission reject the proposal.

(b) *Peer reviewers.* The NHPRC asks from five to ten external peer reviewers, some of whom may be selected from a list provided by you, to evaluate the proposal if the proposal:

- (1) Requests NHPRC funds of \$75,000 or more;
- (2) Requests a grant period of two years or more;
- (3) Involves complex technological processes and issues with which the NHPRC staff may be unfamiliar;
- (4) Is a resubmission that the NHPRC invited; or
- (5) Is not reviewed by a State historical records advisory board.

(c) *Other reviewers.* We may subject on-going documentary editions to special review by NHPRC staff and outside specialists, particularly when:

- (1) You propose to change the project director/editor;
- (2) Your sponsoring institution encounters difficulties or you propose a change in that institution;
- (3) Your major search for materials has been completed;
- (4) Your project finishes publication in one medium and plans to begin publication in another; or
- (5) You change your project's estimate of quantity of publications and/or time needed to complete the project.

(d) *NHPRC staff.* NHPRC staff will analyze the reviewer's comments, State board evaluations, the appropriateness of the project toward Commission goals, the proposal's completeness and conformity to application requirements. The staff will, through a questions letter to you, raise important issues or concerns and allow you the opportunity to respond. The staff will then make recommendations to the Commission.

(e) *The Commission.* After individually reviewing the proposal and recommendations on it from State boards, peer reviewers, and NHPRC staff, Commission members will deliberate on all eligible proposals and recommend to the Archivist of the United States what action to take on each (fund, partially fund, endorse, reject, resubmit, etc.). By statute the Archivist chairs the Commission and has final authority to make or deny a grant.

## 36 CFR Ch. XII (7-1-03 Edition)

### § 1206.54 What formal notification will I receive, and will it contain other information?

(a) The grant award document is a letter from the Archivist of the United States to you, the grantee. The letter and attachments specify terms of the grant. NHPRC staff notifies project directors informally of awards and any conditions soon after the Commission recommends the grant to the Archivist of the United States. Unsuccessful applicants will be notified within two weeks by letter.

(b) The grant period begins and ends on the dates specified in the award document. Grant periods must begin on the first day of a month and end on the last day of a month.

### Subpart F—Grant Administration

#### § 1206.60 Who is responsible for administration of NHPRC grants?

The grantee institution and the project director designated by the institution share primary responsibility for the administration of grants. In the case of grants made to individuals, the individual named as project director has primary responsibility for the administration of the grant.

#### § 1206.62 Where can I find the regulatory requirements that apply to NHPRC grants?

(a) In addition to this part 1206, NARA has issued other regulations that apply to NHPRC grants in 36 CFR ch. XII, subchapter A. NARA also applies the principles and standards in the following Office of Management and Budget (OMB) Circulars for NHPRC grants:

- (1) OMB Circular A-21, "Cost Principles for Educational Institutions";
- (2) OMB Circular A-87, "Cost Principles for State, Local and Indian Tribal Governments";
- (3) OMB Circular A-122, "Cost Principles for Non-Profit Organizations"; and
- (4) OMB Circular A-133, "Audits of States, Local Governments, and Non-Profit Organizations."

(b) These regulations and circulars are available on our Web site at [www.nara.gov/nhprc](http://www.nara.gov/nhprc). Our regulations may also be found at <http://>



**National Archives and Records Administration**

**§ 1206.70**

[www.nara.gov/nara/cfr/subch-a.html](http://www.nara.gov/nara/cfr/subch-a.html), and OMB Circulars at <http://www.whitehouse.gov/omb/grants/>.

(c) Additional policy guidance related to Title VI of the Civil Rights Act of 1964, regarding persons with limited English proficiency, is provided in our guidelines.

**§ 1206.64 When do I need prior written approval for changes to the grant project?**

You must obtain prior written approval from the Commission for any changes in the grant project and terms of the grant, including:

- (a) Revising the scope or objectives of the project;
- (b) Changing the project director or other key project personnel who are specifically named in the grant application or award or related correspondence;
- (c) Contracting out, sub-granting, or otherwise obtaining the services of a third party to perform activities cen-

tral to the purposes of the grant, unless specified in the grant proposal;

(d) Changing the beginning date of the grant or extending the grant period;

(e) Re-budgeting of grants of \$100,000 or more, when cumulative transfers among direct cost categories total more than 10 percent of the total project budget (*i.e.*, grant funds plus other funds). With written approval from the Executive Director of the Commission, grantees may adjust the amounts allocated to existing budget lines for both grant funds and cost sharing and may transfer grant funds among existing NHPRC-funded direct cost categories that appear in the final project budget approved by the Commission at the time of the grant award. Cost-sharing funds may also be shifted among existing cost-sharing categories; and

(f) Creating the following new cost categories:

You must obtain approval from . . .	When your new cost category was not in the final approved budget where . . .
(1) The Executive Director of the Commission, or the Executive Director's designee.	(i) such action seems appropriate for the fulfillment of the original purposes of the grant; and (ii) the amount of funds involved does not exceed 10 percent of the amount of the award, or \$5,000, whichever is less.
(2) The full Commission .....	The amount of funds involved exceeds the amount in paragraph (f)(1)(ii) of this section.

**§ 1206.66 How do I obtain written approval for changes in my grant project?**

(a) You must make all requests for changes in the form of a letter. The grant receiving institution's authorized representative, as indicated on the grant application form (SF 424), must sign the letter. The signed, written response of the Commission's Executive Director, or the Executive Director's designee, will constitute approval for the change.

(b) You must make requests for extension of the grant period not more than two months before the scheduled end of the grant period. We will not allow extensions unless you are up-to-date in your submission of financial and narrative reports.

**§ 1206.68 Are there any changes for which I do not need approval?**

You do not need approval for re-budgeting of grants of less than \$100,000. For such grants:

- (a) You may adjust the amounts allocated to existing budget lines for both grant funds and cost sharing;
- (b) You may transfer grant funds among existing NHPRC-funded direct cost categories that appear in the final project budget approved by the Commission at the time of the grant award; and
- (c) You may also shift cost-sharing funds among existing cost-sharing categories.

**§ 1206.70 What reports am I required to make?**

(a) Grant recipients are generally required to submit annual financial status reports and semi-annual narrative

**§ 1206.72**

progress reports, as well as final financial and narrative reports at the conclusion of the grant period. The grant award document will specify the dates your reports are due.

(b) Send the original reports to the NHPRC, National Archives and Records Administration, 700 Pennsylvania Avenue, NW, Washington, DC 20408-0001. One copy of each records project narrative report must be sent to the State historical records coordinator if the board reviewed the proposal. Other records projects should send courtesy copies of narrative reports to State coordinators whose States are involved in or affected by the project. Provide the names of individuals to whom copies of the report have been sent when submitting the original report to the NHPRC.

**§ 1206.72 What is the format and content of the financial report?**

You must submit financial reports on Standard Form 269 and have them signed by the grantee's authorized representative or by an appropriate institutional fiscal officer. If cost sharing figures are 20 percent less than anticipated in the project budget you must explain the reason for the difference.

**§ 1206.74 What is the format and content of the narrative report?**

(a) Interim narrative reports should summarize briefly the objectives and activities for the entire grant and then focus on those accomplished during the reporting period. The report should include a summary of project activities; whether the project proceeded on schedule; any revisions of the work plan, staffing pattern, or budget; and any web address created by the project. It should include an analysis of the goals met during the reporting period and any goals for the period that were not accomplished. For documentary editing projects, it also must include information about the publication of volumes and the completion of finding aids, as well as any work that is pending with publishers.

(b) The final report must provide a detailed assessment of the project, following the format in paragraph (a) of this section, including whether the goals set in the original proposal were

**36 CFR Ch. XII (7-1-03 Edition)**

realistic; whether there were unpredicted results or outcomes; whether the project encountered unexpected problems and how you faced them; and how you could have improved the project. You must discuss the project's impact, if any, on the grant-receiving institution and others. You must indicate whether all or part of the project activities will be continued after the end of the grant, whether any of these activities will be supported by institutional funds or by grant funds, and if the NHPRC grant was instrumental in obtaining these funds.

(c) The project director must sign narrative reports.

**§ 1206.76 What additional materials must I submit with the final narrative report?**

(a) For records-related projects, you are required to send the NHPRC three copies of any finding aids, reports, manuals, guides, forms, articles about the project, and other materials produced about or based on the grant project at the time that the final narrative report is submitted.

(b) Documentary editing projects must send the NHPRC three copies of any book edition unless support for their publication was provided by an NHPRC subvention grant. For those volumes, presses rather than projects are responsible for submitting the required number of volumes (see § 1206.18(d)). Projects with microform editions must send the NHPRC three copies of the microform guides and indexes produced by the project.

**§ 1206.78 Does the NHPRC have any liability under a grant?**

No, the National Archives and Records Administration (NARA) and the Commission cannot assume any liability for accidents, illnesses, or claims arising out of any work undertaken with the assistance of the grant.

**§ 1206.80 Must I acknowledge NHPRC grant support?**

Yes, grantee institutions, grant project directors, or grant staff personnel may publish results of any work supported by an NHPRC grant without review by the Commission; however,

National Archives and Records Administration

§ 1207.3

publications or other products resulting from the project must acknowledge the assistance of the NHPRC grant.

1207.52 Collection of amounts due.

**PART 1207—UNIFORM ADMINISTRATIVE REQUIREMENTS FOR GRANTS AND COOPERATIVE AGREEMENTS TO STATE AND LOCAL GOVERNMENTS**

**Subpart E—Entitlement [Reserved]**

AUTHORITY: 44 U.S.C. 2104(a); 44 U.S.C. 2501-2506.

SOURCE: 53 FR 8072, 8087, Mar. 11, 1988, unless otherwise noted.

**Subpart A—General**

**Subpart A—General**

- Sec.
- 1207.1 Purpose and scope of this part.
- 1207.2 Scope of subpart.
- 1207.3 Definitions.
- 1207.4 Applicability.
- 1207.5 Effect on other issuances.
- 1207.6 Additions and exceptions.

**§ 1207.1 Purpose and scope of this part.**

This part establishes uniform administrative rules for Federal grants and cooperative agreements and subawards to State, local and Indian tribal governments.

**Subpart B—Pre-Award Requirements**

**§ 1207.2 Scope of subpart.**

- 1207.10 Forms for applying for grants.
- 1207.11 State plans.
- 1207.12 Special grant or subgrant conditions for "high-risk" grantees.

This subpart contains general rules pertaining to this part and procedures for control of exceptions from this part.

**Subpart C—Post-Award Requirements**

**§ 1207.3 Definitions.**

- FINANCIAL ADMINISTRATION
- 1207.20 Standards for financial management systems.
- 1207.21 Payment.
- 1207.22 Allowable costs.
- 1207.23 Period of availability of funds.
- 1207.24 Matching or cost sharing.
- 1207.25 Program income.
- 1207.26 Non-Federal audit.

As used in this part:

*Accrued expenditures* mean the charges incurred by the grantee during a given period requiring the provision of funds for: (1) Goods and other tangible property received; (2) services performed by employees, contractors, subgrantees, subcontractors, and other payees; and (3) other amounts becoming owed under programs for which no current services or performance is required, such as annuities, insurance claims, and other benefit payments.

CHANGES, PROPERTY, AND SUBAWARDS

- 1207.30 Changes.
- 1207.31 Real property.
- 1207.32 Equipment.
- 1207.33 Supplies.
- 1207.34 Copyrights.
- 1207.35 Subawards to debarred and suspended parties.
- 1207.36 Procurement.
- 1207.37 Subgrants.

*Accrued income* means the sum of: (1) Earnings during a given period from services performed by the grantee and goods and other tangible property delivered to purchasers, and (2) amounts becoming owed to the grantee for which no current services or performance is required by the grantee.

REPORTS, RECORDS, RETENTION, AND ENFORCEMENT

- 1207.40 Monitoring and reporting program performance.
- 1207.41 Financial reporting.
- 1207.42 Retention and access requirements for records.
- 1207.43 Enforcement.
- 1207.44 Termination for convenience.

*Acquisition cost* of an item of purchased equipment means the net invoice unit price of the property including the cost of modifications, attachments, accessories, or auxiliary apparatus necessary to make the property usable for the purpose for which it was acquired. Other charges such as the cost of installation, transportation, taxes, duty or protective in-transit insurance, shall be included or excluded

**Subpart D—After-the-Grant Requirements**

- 1207.50 Closeout.
- 1207.51 Later disallowances and adjustments.

from the unit acquisition cost in accordance with the grantee's regular accounting practices.

*Administrative* requirements mean those matters common to grants in general, such as financial management, kinds and frequency of reports, and retention of records. These are distinguished from *programmatic* requirements, which concern matters that can be treated only on a program-by-program or grant-by-grant basis, such as kinds of activities that can be supported by grants under a particular program.

*Awarding agency* means (1) with respect to a grant, the Federal agency, and (2) with respect to a subgrant, the party that awarded the subgrant.

*Cash contributions* means the grantee's cash outlay, including the outlay of money contributed to the grantee or subgrantee by other public agencies and institutions, and private organizations and individuals. When authorized by Federal legislation, Federal funds received from other assistance agreements may be considered as grantee or subgrantee cash contributions.

*Contract* means (except as used in the definitions for *grant* and *subgrant* in this section and except where qualified by *Federal*) a procurement contract under a grant or subgrant, and means a procurement subcontract under a contract.

*Cost sharing or matching* means the value of the third party in-kind contributions and the portion of the costs of a federally assisted project or program not borne by the Federal Government.

*Cost-type contract* means a contract or subcontract under a grant in which the contractor or subcontractor is paid on the basis of the costs it incurs, with or without a fee.

*Equipment* means tangible, non-expendable, personal property having a useful life of more than one year and an acquisition cost of \$5,000 or more per unit. A grantee may use its own definition of equipment provided that such definition would at least include all equipment defined above.

*Expenditure report* means: (1) For non-construction grants, the SF-269 "Financial Status Report" (or other equivalent report); (2) for construction

grants, the SF-271 "Outlay Report and Request for Reimbursement" (or other equivalent report).

*Federally recognized Indian tribal government* means the governing body or a governmental agency of any Indian tribe, band, nation, or other organized group or community (including any Native village as defined in section 3 of the Alaska Native Claims Settlement Act, 85 Stat 688) certified by the Secretary of the Interior as eligible for the special programs and services provided by him through the Bureau of Indian Affairs.

*Government* means a State or local government or a federally recognized Indian tribal government.

*Grant* means an award of financial assistance, including cooperative agreements, in the form of money, or property in lieu of money, by the Federal Government to an eligible grantee. The term does not include technical assistance which provides services instead of money, or other assistance in the form of revenue sharing, loans, loan guarantees, interest subsidies, insurance, or direct appropriations. Also, the term does not include assistance, such as a fellowship or other lump sum award, which the grantee is not required to account for.

*Grantee* means the government to which a grant is awarded and which is accountable for the use of the funds provided. The grantee is the entire legal entity even if only a particular component of the entity is designated in the grant award document.

*Local government* means a county, municipality, city, town, township, local public authority (including any public and Indian housing agency under the United States Housing Act of 1937) school district, special district, intrastate district, council of governments (whether or not incorporated as a nonprofit corporation under state law), any other regional or interstate government entity, or any agency or instrumentality of a local government.

*Obligations* means the amounts of orders placed, contracts and subgrants awarded, goods and services received, and similar transactions during a given period that will require payment by the grantee during the same or a future period.

*OMB* means the United States Office of Management and Budget.

*Outlays* (expenditures) mean charges made to the project or program. They may be reported on a cash or accrual basis. For reports prepared on a cash basis, outlays are the sum of actual cash disbursement for direct charges for goods and services, the amount of indirect expense incurred, the value of in-kind contributions applied, and the amount of cash advances and payments made to contractors and subgrantees. For reports prepared on an accrued expenditure basis, outlays are the sum of actual cash disbursements, the amount of indirect expense incurred, the value of in-kind contributions applied, and the new increase (or decrease) in the amounts owed by the grantee for goods and other property received, for services performed by employees, contractors, subgrantees, subcontractors, and other payees, and other amounts becoming owed under programs for which no current services or performance are required, such as annuities, insurance claims, and other benefit payments.

*Percentage of completion method* refers to a system under which payments are made for construction work according to the percentage of completion of the work, rather than to the grantee's cost incurred.

*Prior approval* means documentation evidencing consent prior to incurring specific cost.

*Real property* means land, including land improvements, structures and appurtenances thereto, excluding movable machinery and equipment.

*Share*, when referring to the awarding agency's portion of real property, equipment or supplies, means the same percentage as the awarding agency's portion of the acquiring party's total costs under the grant to which the acquisition costs under the grant to which the acquisition cost of the property was charged. Only costs are to be counted—not the value of third-party in-kind contributions.

*State* means any of the several States of the United States, the District of Columbia, the Commonwealth of Puerto Rico, any territory or possession of the United States, or any agency or instrumentality of a State exclusive of local governments. The term does not

include any public and Indian housing agency under United States Housing Act of 1937.

*Subgrant* means an award of financial assistance in the form of money, or property in lieu of money, made under a grant by a grantee to an eligible subgrantee. The term includes financial assistance when provided by contractual legal agreement, but does not include procurement purchases, nor does it include any form of assistance which is excluded from the definition of *grant* in this part.

*Subgrantee* means the government or other legal entity to which a subgrant is awarded and which is accountable to the grantee for the use of the funds provided.

*Supplies* means all tangible personal property other than *equipment* as defined in this part.

*Suspension* means depending on the context, either (1) temporary withdrawal of the authority to obligate grant funds pending corrective action by the grantee or subgrantee or a decision to terminate the grant, or (2) an action taken by a suspending official in accordance with agency regulations implementing E.O. 12549 to immediately exclude a person from participating in grant transactions for a period, pending completion of an investigation and such legal or debarment proceedings as may ensue.

*Termination* means permanent withdrawal of the authority to obligate previously-awarded grant funds before that authority would otherwise expire. It also means the voluntary relinquishment of that authority by the grantee or subgrantee. *Termination* does not include: (1) Withdrawal of funds awarded on the basis of the grantee's underestimate of the unobligated balance in a prior period; (2) withdrawal of the unobligated balance as of the expiration of a grant; (3) refusal to extend a grant or award additional funds, to make a competing or noncompeting continuation, renewal, extension, or supplemental award; or (4) voiding of a grant upon determination that the award was obtained fraudulently, or was otherwise illegal or invalid from inception.

*Terms of a grant or subgrant* mean all requirements of the grant or subgrant,

## § 1207.4

## 36 CFR Ch. XII (7-1-03 Edition)

whether in statute, regulations, or the award document.

*Third party in-kind contributions* mean property or services which benefit a federally assisted project or program and which are contributed by non-Federal third parties without charge to the grantee, or a cost-type contractor under the grant agreement.

*Unliquidated obligations* for reports prepared on a cash basis mean the amount of obligations incurred by the grantee that has not been paid. For reports prepared on an accrued expenditure basis, they represent the amount of obligations incurred by the grantee for which an outlay has not been recorded.

*Unobligated balance* means the portion of the funds authorized by the Federal agency that has not been obligated by the grantee and is determined by deducting the cumulative obligations from the cumulative funds authorized.

### § 1207.4 Applicability.

(a) *General.* Subparts A through D of this part apply to all grants and subgrants to governments, except where inconsistent with Federal statutes or with regulations authorized in accordance with the exception provision of § 1207.6, or:

(1) Grants and subgrants to State and local institutions of higher education or State and local hospitals.

(2) The block grants authorized by the Omnibus Budget Reconciliation Act of 1981 (Community Services; Preventive Health and Health Services; Alcohol, Drug Abuse, and Mental Health Services; Maternal and Child Health Services; Social Services; Low-Income Home Energy Assistance; States' Program of Community Development Block Grants for Small Cities; and Elementary and Secondary Education other than programs administered by the Secretary of Education under title V, subtitle D, chapter 2, section 583—the Secretary's discretionary grant program) and titles I-III of the Job Training Partnership Act of 1982 and under the Public Health Services Act (section 1921), Alcohol and Drug Abuse Treatment and Rehabilitation Block Grant and part C of title V, Mental

Health Service for the Homeless Block Grant).

(3) Entitlement grants to carry out the following programs of the Social Security Act:

(i) Aid to Needy Families with Dependent Children (title IV-A of the Act, not including the Work Incentive Program (WIN) authorized by section 402(a)19(G); HHS grants for WIN are subject to this part);

(ii) Child Support Enforcement and Establishment of Paternity (title IV-D of the Act);

(iii) Foster Care and Adoption Assistance (title IV-E of the Act);

(iv) Aid to the Aged, Blind, and Disabled (titles I, X, XIV, and XVI-AABD of the Act); and

(v) Medical Assistance (Medicaid) (title XIX of the Act) not including the State Medicaid Fraud Control program authorized by section 1903(a)(6)(B).

(4) Entitlement grants under the following programs of The National School Lunch Act:

(i) School Lunch (section 4 of the Act),

(ii) Commodity Assistance (section 6 of the Act),

(iii) Special Meal Assistance (section 11 of the Act),

(iv) Summer Food Service for Children (section 13 of the Act), and

(v) Child Care Food Program (section 17 of the Act).

(5) Entitlement grants under the following programs of The Child Nutrition Act of 1966:

(i) Special Milk (section 3 of the Act), and

(ii) School Breakfast (section 4 of the Act).

(6) Entitlement grants for State Administrative expenses under The Food Stamp Act of 1977 (section 16 of the Act).

(7) A grant for an experimental, pilot, or demonstration project that is also supported by a grant listed in paragraph (a)(3) of this section;

(8) Grant funds awarded under subsection 412(e) of the Immigration and Nationality Act (8 U.S.C. 1522(e)) and subsection 501(a) of the Refugee Education Assistance Act of 1980 (Pub. L.

96-422, 94 Stat. 1809), for cash assistance, medical assistance, and supplemental security income benefits to refugees and entrants and the administrative costs of providing the assistance and benefits;

(9) Grants to local education agencies under 20 U.S.C. 236 through 241-1(a), and 242 through 244 (portions of the Impact Aid program), except for 20 U.S.C. 238(d)(2)(c) and 240(f) (Entitlement Increase for Handicapped Children); and

(10) Payments under the Veterans Administration's State Home Per Diem Program (38 U.S.C. 641(a)).

(b) *Entitlement programs.* Entitlement programs enumerated above in § 1207.4(a) (3) through (8) are subject to subpart E.

#### § 1207.5 Effect on other issuances.

All other grants administration provisions of codified program regulations, program manuals, handbooks and other nonregulatory materials which are inconsistent with this part are superseded, except to the extent they are required by statute, or authorized in accordance with the exception provision in § 1207.6.

#### § 1207.6 Additions and exceptions

(a) For classes of grants and grantees subject to this part, Federal agencies may not impose additional administrative requirements except in codified regulations published in the FEDERAL REGISTER.

(b) Exceptions for classes of grants or grantees may be authorized only by OMB.

(c) Exceptions on a case-by-case basis and for subgrantees may be authorized by the affected Federal agencies.

### Subpart B—Pre-Award Requirements

#### § 1207.10 Forms for applying for grants.

(a) *Scope.* (1) This section prescribes forms and instructions to be used by governmental organizations (except hospitals and institutions of higher education operated by a government) in applying for grants. This section is not applicable, however, to formula grant programs which do not require

applicants to apply for funds on a project basis.

(2) This section applies only to applications to Federal agencies for grants, and is not required to be applied by grantees in dealing with applicants for subgrants. However, grantees are encouraged to avoid more detailed or burdensome application requirements for subgrants.

(b) *Authorized forms and instructions for governmental organizations.* (1) In applying for grants, applicants shall only use standard application forms or those prescribed by the granting agency with the approval of OMB under the Paperwork Reduction Act of 1980.

(2) Applicants are not required to submit more than the original and two copies of preapplications or applications.

(3) Applicants must follow all applicable instructions that bear OMB clearance numbers. Federal agencies may specify and describe the programs, functions, or activities that will be used to plan, budget, and evaluate the work under a grant. Other supplementary instructions may be issued only with the approval of OMB to the extent required under the Paperwork Reduction Act of 1980. For any standard form, except the SF-424 facesheet, Federal agencies may shade out or instruct the applicant to disregard any line item that is not needed.

(4) When a grantee applies for additional funding (such as a continuation or supplemental award) or amends a previously submitted application, only the affected pages need be submitted. Previously submitted pages with information that is still current need not be resubmitted.

#### § 1207.11 State plans.

(a) *Scope.* The statutes for some programs require States to submit plans before receiving grants. Under regulations implementing Executive Order 12372, "Intergovernmental Review of Federal Programs," States are allowed to simplify, consolidate and substitute plans. This section contains additional provisions for plans that are subject to regulations implementing the Executive order.

§ 1207.12

(b) *Requirements.* A State need meet only Federal administrative or programmatic requirements for a plan that are in statutes or codified regulations.

(c) *Assurances.* In each plan the State will include an assurance that the State shall comply with all applicable Federal statutes and regulations in effect with respect to the periods for which it receives grant funding. For this assurance and other assurances required in the plan, the State may:

(1) Cite by number the statutory or regulatory provisions requiring the assurances and affirm that it gives the assurances required by those provisions,

(2) Repeat the assurance language in the statutes or regulations, or

(3) Develop its own language to the extent permitted by law.

(d) *Amendments.* A State will amend a plan whenever necessary to reflect: (1) New or revised Federal statutes or regulations or (2) a material change in any State law, organization, policy, or State agency operation. The State will obtain approval for the amendment and its effective date but need submit for approval only the amended portions of the plan.

§ 1207.12 **Special grant or subgrant conditions for “high-risk” grantees.**

(a) A grantee or subgrantee may be considered “high risk” if an awarding agency determines that a grantee or subgrantee:

(1) Has a history of unsatisfactory performance, or

(2) Is not financially stable, or

(3) Has a management system which does not meet the management standards set forth in this part, or

(4) Has not conformed to terms and conditions of previous awards, or

(5) Is otherwise not responsible; and if the awarding agency determines that an award will be made, special conditions and/or restrictions shall correspond to the high risk condition and shall be included in the award.

(b) Special conditions or restrictions may include:

(1) Payment on a reimbursement basis;

(2) Withholding authority to proceed to the next phase until receipt of evi-

dence of acceptable performance within a given funding period;

(3) Requiring additional, more detailed financial reports;

(4) Additional project monitoring;

(5) Requiring the grantee or subgrantee to obtain technical or management assistance; or

(6) Establishing additional prior approvals.

(c) If an awarding agency decides to impose such conditions, the awarding official will notify the grantee or subgrantee as early as possible, in writing, of:

(1) The nature of the special conditions/restrictions;

(2) The reason(s) for imposing them;

(3) The corrective actions which must be taken before they will be removed and the time allowed for completing the corrective actions and

(4) The method of requesting reconsideration of the conditions/restrictions imposed.

**Subpart C—Post-Award Requirements**

FINANCIAL ADMINISTRATION

§ 1207.20 **Standards for financial management systems.**

(a) A State must expand and account for grant funds in accordance with State laws and procedures for expending and accounting for its own funds. Fiscal control and accounting procedures of the State, as well as its subgrantees and cost-type contractors, must be sufficient to—

(1) Permit preparation of reports required by this part and the statutes authorizing the grant, and

(2) Permit the tracing of funds to a level of expenditures adequate to establish that such funds have not been used in violation of the restrictions and prohibitions of applicable statutes.

(b) The financial management systems of other grantees and subgrantees must meet the following standards:

(1) *Financial reporting.* Accurate, current, and complete disclosure of the financial results of financially assisted activities must be made in accordance with the financial reporting requirements of the grant or subgrant.



(2) *Accounting records.* Grantees and subgrantees must maintain records which adequately identify the source and application of funds provided for financially-assisted activities. These records must contain information pertaining to grant or subgrant awards and authorizations, obligations, unobligated balances, assets, liabilities, outlays or expenditures, and income.

(3) *Internal control.* Effective control and accountability must be maintained for all grant and subgrant cash, real and personal property, and other assets. Grantees and subgrantees must adequately safeguard all such property and must assure that it is used solely for authorized purposes.

(4) *Budget control.* Actual expenditures or outlays must be compared with budgeted amounts for each grant or subgrant. Financial information must be related to performance or productivity data, including the development of unit cost information whenever appropriate or specifically required in the grant or subgrant agreement. If unit cost data are required, estimates based on available documentation will be accepted whenever possible.

(5) *Allowable cost.* Applicable OMB cost principles, agency program regulations, and the terms of grant and subgrant agreements will be followed in determining the reasonableness, allowability, and allocability of costs.

(6) *Source documentation.* Accounting records must be supported by such source documentation as cancelled checks, paid bills, payrolls, time and attendance records, contract and subgrant award documents, etc.

(7) *Cash management.* Procedures for minimizing the time elapsing between the transfer of funds from the U.S. Treasury and disbursement by grantees and subgrantees must be followed whenever advance payment procedures are used. Grantees must establish reasonable procedures to ensure the receipt of reports on subgrantees' cash balances and cash disbursements in sufficient time to enable them to prepare complete and accurate cash transactions reports to the awarding agency. When advances are made by letter-of-credit or electronic transfer of funds methods, the grantee must make

drawdowns as close as possible to the time of making disbursements. Grantees must monitor cash drawdowns by their subgrantees to assure that they conform substantially to the same standards of timing and amount as apply to advances to the grantees.

(c) An awarding agency may review the adequacy of the financial management system of any applicant for financial assistance as part of a preaward review or at any time subsequent to award.

#### § 1207.21 Payment.

(a) *Scope.* This section prescribes the basic standard and the methods under which a Federal agency will make payments to grantees, and grantees will make payments to subgrantees and contractors.

(b) *Basic standard.* Methods and procedures for payment shall minimize the time elapsing between the transfer of funds and disbursement by the grantee or subgrantee, in accordance with Treasury regulations at 31 CFR part 205.

(c) *Advances.* Grantees and subgrantees shall be paid in advance, provided they maintain or demonstrate the willingness and ability to maintain procedures to minimize the time elapsing between the transfer of the funds and their disbursement by the grantee or subgrantee.

(d) *Reimbursement.* Reimbursement shall be the preferred method when the requirements in paragraph (c) of this section are not met. Grantees and subgrantees may also be paid by reimbursement for any construction grant. Except as otherwise specified in regulation, Federal agencies shall not use the percentage of completion method to pay construction grants. The grantee or subgrantee may use that method to pay its construction contractor, and if it does, the awarding agency's payments to the grantee or subgrantee will be based on the grantee's or subgrantee's actual rate of disbursement.

(e) *Working capital advances.* If a grantee cannot meet the criteria for advance payments described in paragraph (c) of this section, and the Federal agency has determined that reimbursement is not feasible because the

**§ 1207.22**

grantee lacks sufficient working capital, the awarding agency may provide cash or a working capital advance basis. Under this procedure the awarding agency shall advance cash to the grantee to cover its estimated disbursement needs for an initial period generally geared to the grantee's disbursing cycle. Thereafter, the awarding agency shall reimburse the grantee for its actual cash disbursements. The working capital advance method of payment shall not be used by grantees or subgrantees if the reason for using such method is the unwillingness or inability of the grantee to provide timely advances to the subgrantee to meet the subgrantee's actual cash disbursements.

(f) *Effect of program income, refunds, and audit recoveries on payment.* (1) Grantees and subgrantees shall disburse repayments to and interest earned on a revolving fund before requesting additional cash payments for the same activity.

(2) Except as provided in paragraph (f)(1) of this section, grantees and subgrantees shall disburse program income, rebates, refunds, contract settlements, audit recoveries and interest earned on such funds before requesting additional cash payments.

(g) *Withholding payments.* (1) Unless otherwise required by Federal statute, awarding agencies shall not withhold payments for proper charges incurred by grantees or subgrantees unless—

(i) The grantee or subgrantee has failed to comply with grant award conditions or

(ii) The grantee or subgrantee is indebted to the United States.

(2) Cash withheld for failure to comply with grant award condition, but without suspension of the grant, shall be released to the grantee upon subsequent compliance. When a grant is suspended, payment adjustments will be made in accordance with § 1207.43(c).

(3) A Federal agency shall not make payment to grantees for amounts that are withheld by grantees or subgrantees from payment to contractors to assure satisfactory completion of work. Payments shall be made by the Federal agency when the grantees or subgrantees actually disburse the withheld funds to the contractors or to es-

**36 CFR Ch. XII (7-1-03 Edition)**

crow accounts established to assure satisfactory completion of work.

(h) *Cash depositories.* (1) Consistent with the national goal of expanding the opportunities for minority business enterprises, grantees and subgrantees are encouraged to use minority banks (a bank which is owned at least 50 percent by minority group members). A list of minority owned banks can be obtained from the Minority Business Development Agency, Department of Commerce, Washington, DC 20230.

(2) A grantee or subgrantee shall maintain a separate bank account only when required by Federal-State agreement.

(i) *Interest earned on advances.* Except for interest earned on advances of funds exempt under the Intergovernmental Cooperation Act (31 U.S.C. 6501 et seq.) and the Indian Self-Determination Act (23 U.S.C. 450), grantees and subgrantees shall promptly, but at least quarterly, remit interest earned on advances to the Federal agency. The grantee or subgrantee may keep interest amounts up to \$100 per year for administrative expenses.

**§ 1207.22 Allowable costs.**

(a) *Limitation on use of funds.* Grant funds may be used only for:

(1) The allowable costs of the grantees, subgrantees and cost-type contractors, including allowable costs in the form of payments to fixed-price contractors; and

(2) Reasonable fees or profit to cost-type contractors but not any fee or profit (or other increment above allowable costs) to the grantee or subgrantee.

(b) *Applicable cost principles.* For each kind of organization, there is a set of Federal principles for determining allowable costs. Allowable costs will be determined in accordance with the cost principles applicable to the organization incurring the costs. The following chart lists the kinds of organizations and the applicable cost principles.

For the costs of a—	Use the principles in—
State, local or Indian tribal government.	OMB Circular A-87.

For the costs of a—	Use the principles in—
Private nonprofit organization other than an (1) institution of higher education, (2) hospital, or (3) organization named in OMB Circular A-122 as not subject to that circular.	OMB Circular A-122.
Educational institutions. .... For-profit organization other than a hospital and an organization named in OMB Circular A-122 as not subject to that circular.	OMB Circular A-21. 48 CFR part 31. Contract Cost Principles and Procedures, or uniform cost accounting standards that comply with cost principles acceptable to the Federal agency.

quirement may not be met by costs borne by another Federal grant. This prohibition does not apply to income earned by a grantee or subgrantee from a contract awarded under another Federal grant.

(2) *General revenue sharing.* For the purpose of this section, general revenue sharing funds distributed under 31 U.S.C. 6702 are not considered Federal grant funds.

(3) *Cost or contributions counted towards other Federal costs-sharing requirements.* Neither costs nor the values of third party in-kind contributions may count towards satisfying a cost sharing or matching requirement of a grant agreement if they have been or will be counted towards satisfying a cost sharing or matching requirement of another Federal grant agreement, a Federal procurement contract, or any other award of Federal funds.

(4) *Costs financed by program income.* Costs financed by program income, as defined in §1207.25, shall not count towards satisfying a cost sharing or matching requirement unless they are expressly permitted in the terms of the assistance agreement. (This use of general program income is described in §1207.25(g).)

(5) *Services or property financed by income earned by contractors.* Contractors under a grant may earn income from the activities carried out under the contract in addition to the amounts earned from the party awarding the contract. No costs of services or property supported by this income may count toward satisfying a cost sharing or matching requirement unless other provisions of the grant agreement expressly permit this kind of income to be used to meet the requirement.

(6) *Records.* Costs and third party in-kind contributions counting towards satisfying a cost sharing or matching requirement must be verifiable from the records of grantees and subgrantee or cost-type contractors. These records must show how the value placed on third party in-kind contributions was derived. To the extent feasible, volunteer services will be supported by the same methods that the organization uses to support the allocability of regular personnel costs.

**§ 1207.23 Period of availability of funds.**

(a) *General.* Where a funding period is specified, a grantee may charge to the award only costs resulting from obligations of the funding period unless carryover of unobligated balances is permitted, in which case the carryover balances may be charged for costs resulting from obligations of the subsequent funding period.

(b) *Liquidation of obligations.* A grantee must liquidate all obligations incurred under the award not later than 90 days after the end of the funding period (or as specified in a program regulation) to coincide with the submission of the annual Financial Status Report (SF-269). The Federal agency may extend this deadline at the request of the grantee.

**§ 1207.24 Matching or cost sharing.**

(a) *Basic rule: Costs and contributions acceptable.* With the qualifications and exceptions listed in paragraph (b) of this section, a matching or cost sharing requirement may be satisfied by either or both of the following:

(1) Allowable costs incurred by the grantee, subgrantee or a cost-type contractor under the assistance agreement. This includes allowable costs borne by non-Federal grants or by others cash donations from non-Federal third parties.

(2) The value of third party in-kind contributions applicable to the period to which the cost sharing or matching requirements applies.

(b) *Qualifications and exceptions—(1) Costs borne by other Federal grant agreements.* Except as provided by Federal statute, a cost sharing or matching re-

(7) *Special standards for third party in-kind contributions.* (i) Third party in-kind contributions count towards satisfying a cost sharing or matching requirement only where, if the party receiving the contributions were to pay for them, the payments would be allowable costs.

(ii) Some third party in-kind contributions are goods and services that, if the grantee, subgrantee, or contractor receiving the contribution had to pay for them, the payments would have been an indirect costs. Costs sharing or matching credit for such contributions shall be given only if the grantee, subgrantee, or contractor has established, along with its regular indirect cost rate, a special rate for allocating to individual projects or programs the value of the contributions.

(iii) A third party in-kind contribution to a fixed-price contract may count towards satisfying a cost sharing or matching requirement only if it results in:

(A) An increase in the services or property provided under the contract (without additional cost to the grantee or subgrantee) or

(B) A cost savings to the grantee or subgrantee.

(iv) The values placed on third party in-kind contributions for cost sharing or matching purposes will conform to the rules in the succeeding sections of this part. If a third party in-kind contribution is a type not treated in those sections, the value placed upon it shall be fair and reasonable.

(c) *Valuation of donated services—(1) Volunteer services.* Unpaid services provided to a grantee or subgrantee by individuals will be valued at rates consistent with those ordinarily paid for similar work in the grantee's or subgrantee's organization. If the grantee or subgrantee does not have employees performing similar work, the rates will be consistent with those ordinarily paid by other employers for similar work in the same labor market. In either case, a reasonable amount for fringe benefits may be included in the valuation.

(2) *Employees of other organizations.* When an employer other than a grantee, subgrantee, or cost-type contractor furnishes free of charge the services of

an employee in the employee's normal line of work, the services will be valued at the employee's regular rate of pay exclusive of the employee's fringe benefits and overhead costs. If the services are in a different line of work, paragraph (c)(1) of this section applies.

(d) *Valuation of third party donated supplies and loaned equipment or space.*

(1) If a third party donates supplies, the contribution will be valued at the market value of the supplies at the time of donation.

(2) If a third party donates the use of equipment or space in a building but retains title, the contribution will be valued at the fair rental rate of the equipment or space.

(e) *Valuation of third party donated equipment, buildings, and land.* If a third party donates equipment, buildings, or land, and title passes to a grantee or subgrantee, the treatment of the donated property will depend upon the purpose of the grant or subgrant, as follows:

(1) *Awards for capital expenditures.* If the purpose of the grant or subgrant is to assist the grantee or subgrantee in the acquisition of property, the market value of that property at the time of donation may be counted as cost sharing or matching.

(2) *Other awards.* If assisting in the acquisition of property is not the purpose of the grant or subgrant, paragraphs (e)(2)(i) and (ii) of this section apply:

(i) If approval is obtained from the awarding agency, the market value at the time of donation of the donated equipment or buildings and the fair rental rate of the donated land may be counted as cost sharing or matching. In the case of a subgrant, the terms of the grant agreement may require that the approval be obtained from the Federal agency as well as the grantee. In all cases, the approval may be given only if a purchase of the equipment or rental of the land would be approved as an allowable direct cost. If any part of the donated property was acquired with Federal funds, only the non-federal share of the property may be counted as cost-sharing or matching.

(ii) If approval is not obtained under paragraph (e)(2)(i) of this section, no amount may be counted for donated

land, and only depreciation or use allowances may be counted for donated equipment and buildings. The depreciation or use allowances for this property are not treated as third party in-kind contributions. Instead, they are treated as costs incurred by the grantee or subgrantee. They are computed and allocated (usually as indirect costs) in accordance with the cost principles specified in § 1207.22, in the same way as depreciation or use allowances for purchased equipment and buildings. The amount of depreciation or use allowances for donated equipment and buildings is based on the property's market value at the time it was donated.

(f) *Valuation of grantee or subgrantee donated real property for construction/acquisition.* If a grantee or subgrantee donates real property for a construction or facilities acquisition project, the current market value of that property may be counted as cost sharing or matching. If any part of the donated property was acquired with Federal funds, only the non-federal share of the property may be counted as cost sharing or matching.

(g) *Appraisal of real property.* In some cases under paragraphs (d), (e) and (f) of this section, it will be necessary to establish the market value of land or a building or the fair rental rate of land or of space in a building. In these cases, the Federal agency may require the market value or fair rental value be set by an independent appraiser, and that the value or rate be certified by the grantee. This requirement will also be imposed by the grantee on subgrantees.

#### § 1207.25 Program income.

(a) *General.* Grantees are encouraged to earn income to defray program costs. Program income includes income from fees for services performed, from the use or rental of real or personal property acquired with grant funds, from the sale of commodities or items fabricated under a grant agreement, and from payments of principal and interest on loans made with grant funds. Except as otherwise provided in regulations of the Federal agency, program income does not include interest on grant funds, rebates, credits, discounts, refunds, etc. and interest earned on any of them.

(b) *Definition of program income.* Program income means gross income received by the grantee or subgrantee directly generated by a grant supported activity, or earned only as a result of the grant agreement during the grant period. "During the grant period" is the time between the effective date of the award and the ending date of the award reflected in the final financial report.

(c) *Cost of generating program income.* If authorized by Federal regulations or the grant agreement, costs incident to the generation of program income may be deducted from gross income to determine program income.

(d) *Governmental revenues.* Taxes, special assessments, levies, fines, and other such revenues raised by a grantee or subgrantee are not program income unless the revenues are specifically identified in the grant agreement or Federal agency regulations as program income.

(e) *Royalties.* Income from royalties and license fees for copyrighted material, patents, and inventions developed by a grantee or subgrantee is program income only if the revenues are specifically identified in the grant agreement or Federal agency regulations as program income. (See § 1207.34.)

(f) *Property.* Proceeds from the sale of real property or equipment will be handled in accordance with the requirements of §§ 1207.31 and 1207.32.

(g) *Use of program income.* Program income shall be deducted from outlays which may be both Federal and non-Federal as described below, unless the Federal agency regulations or the grant agreement specify another alternative (or a combination of the alternatives). In specifying alternatives, the Federal agency may distinguish between income earned by the grantee and income earned by subgrantees and between the sources, kinds, or amounts of income. When Federal agencies authorize the alternatives in paragraphs (g) (2) and (3) of this section, program income in excess of any limits stipulated shall also be deducted from outlays.

(1) *Deduction.* Ordinarily program income shall be deducted from total allowable costs to determine the net allowable costs. Program income shall be

§ 1207.26

36 CFR Ch. XII (7-1-03 Edition)

used for current costs unless the Federal agency authorizes otherwise. Program income which the grantee did not anticipate at the time of the award shall be used to reduce the Federal agency and grantee contributions rather than to increase the funds committed to the project.

(2) *Addition.* When authorized, program income may be added to the funds committed to the grant agreement by the Federal agency and the grantee. The program income shall be used for the purposes and under the conditions of the grant agreement.

(3) *Cost sharing or matching.* When authorized, program income may be used to meet the cost sharing or matching requirement of the grant agreement. The amount of the Federal grant award remains the same.

(h) *Income after the award period.* There are no Federal requirements governing the disposition of program income earned after the end of the award period (i.e., until the ending date of the final financial report, see paragraph (a) of this section), unless the terms of the agreement or the Federal agency regulations provide otherwise.

§ 1207.26 Non-Federal audit.

(a) *Basic rule.* Grantees and subgrantees are responsible for obtaining audits in accordance with the Single Audit Act Amendments of 1996 (31 U.S.C. 7501-7507) and revised OMB Circular A-133, "Audits of States, Local Governments, and Non-Profit Organizations." The audits shall be made by an independent auditor in accordance with generally accepted government auditing standards covering financial audits.

(b) *Subgrantees.* State or local governments, as those terms are defined for purposes of the Single Audit Act Amendments of 1996, that provide Federal awards to a subgrantee, which expends \$300,000 or more (or other amount as specified by OMB) in Federal awards in a fiscal year, shall:

(1) Determine whether State or local subgrantees have met the audit requirements of the Act and whether subgrantees covered by OMB Circular A-110, "Uniform Administrative Requirements for Grants and Agreements with Institutions of Higher Education, Hos-

pitals, and Other Non-Profit Organizations," have met the audit requirements of the Act. Commercial contractors (private for-profit and private and governmental organizations) providing goods and services to State and local governments are not required to have a single audit performed. State and local governments should use their own procedures to ensure that the contractor has complied with laws and regulations affecting the expenditure of Federal funds;

(2) Determine whether the subgrantee spent Federal assistance funds provided in accordance with applicable laws and regulations. This may be accomplished by reviewing an audit of the subgrantee made in accordance with the Act, Circular A-110, or through other means (e.g., program reviews) if the subgrantee has not had such an audit;

(3) Ensure that appropriate corrective action is taken within six months after receipt of the audit report in instance of noncompliance with Federal laws and regulations;

(4) Consider whether subgrantee audits necessitate adjustment of the grantee's own records; and

(5) Require each subgrantee to permit independent auditors to have access to the records and financial statements.

(c) *Auditor selection.* In arranging for audit services, §1207.36 shall be followed.

[53 FR 8072, 8087, Mar. 11, 1988, as amended at 62 FR 45939, 45943, Aug. 29, 1997]

CHANGES, PROPERTY, AND SUBAWARDS

§ 1207.30 Changes.

(a) *General.* Grantees and subgrantees are permitted to rebudget within the approved direct cost budget to meet unanticipated requirements and may make limited program changes to the approved project. However, unless waived by the awarding agency, certain types of post-award changes in budgets and projects shall require the prior written approval of the awarding agency.

(b) *Relation to cost principles.* The applicable cost principles (see §1207.22) contain requirements for prior approval of certain types of costs. Except where waived, those requirements

apply to all grants and subgrants even if paragraphs (c) through (f) of this section do not.

(c) *Budget changes*—(1) *Nonconstruction projects*. Except as stated in other regulations or an award document, grantees or subgrantees shall obtain the prior approval of the awarding agency whenever any of the following changes is anticipated under a non-construction award:

(i) Any revision which would result in the need for additional funding.

(ii) Unless waived by the awarding agency, cumulative transfers among direct cost categories, or, if applicable, among separately budgeted programs, projects, functions, or activities which exceed or are expected to exceed ten percent of the current total approved budget, whenever the awarding agency's share exceeds \$100,000.

(iii) Transfer of funds allotted for training allowances (i.e., from direct payments to trainees to other expense categories).

(2) *Construction projects*. Grantees and subgrantees shall obtain prior written approval for any budget revision which would result in the need for additional funds.

(3) *Combined construction and non-construction projects*. When a grant or subgrant provides funding for both construction and nonconstruction activities, the grantee or subgrantee must obtain prior written approval from the awarding agency before making any fund or budget transfer from non-construction to construction or vice versa.

(d) *Programmatic changes*. Grantees or subgrantees must obtain the prior approval of the awarding agency whenever any of the following actions is anticipated:

(1) Any revision of the scope or objectives of the project (regardless of whether there is an associated budget revision requiring prior approval).

(2) Need to extend the period of availability of funds.

(3) Changes in key persons in cases where specified in an application or a grant award. In research projects, a change in the project director or principal investigator shall always require approval unless waived by the awarding agency.

(4) Under nonconstruction projects, contracting out, subgranting (if authorized by law) or otherwise obtaining the services of a third party to perform activities which are central to the purposes of the award. This approval requirement is in addition to the approval requirements of §1207.36 but does not apply to the procurement of equipment, supplies, and general support services.

(e) *Additional prior approval requirements*. The awarding agency may not require prior approval for any budget revision which is not described in paragraph (c) of this section.

(f) *Requesting prior approval*. (1) A request for prior approval of any budget revision will be in the same budget form the grantee used in its application and shall be accompanied by a narrative justification for the proposed revision.

(2) A request for a prior approval under the applicable Federal cost principles (see §1207.22) may be made by letter.

(3) A request by a subgrantee for prior approval will be addressed in writing to the grantee. The grantee will promptly review such request and shall approve or disapprove the request in writing. A grantee will not approve any budget or project revision which is inconsistent with the purpose or terms and conditions of the Federal grant to the grantee. If the revision, requested by the subgrantee would result in a change to the grantee's approved project which requires Federal prior approval, the grantee will obtain the Federal agency's approval before approving the subgrantee's request.

#### § 1207.31 Real property.

(a) *Title*. Subject to the obligations and conditions set forth in this section, title to real property acquired under a grant or subgrant will vest upon acquisition in the grantee or subgrantee respectively.

(b) *Use*. Except as otherwise provided by Federal statutes, real property will be used for the originally authorized purposes as long as needed for that purposes, and the grantee or subgrantee shall not dispose of or encumber its title or other interests.

(c) *Disposition.* When real property is no longer needed for the originally authorized purpose, the grantee or subgrantee will request disposition instructions from the awarding agency. The instructions will provide for one of the following alternatives:

(1) *Retention of title.* Retain title after compensating the awarding agency. The amount paid to the awarding agency will be computed by applying the awarding agency's percentage of participation in the cost of the original purchase to the fair market value of the property. However, in those situations where a grantee or subgrantee is disposing of real property acquired with grant funds and acquiring replacement real property under the same program, the net proceeds from the disposition may be used as an offset to the cost of the replacement property.

(2) *Sale of property.* Sell the property and compensate the awarding agency. The amount due to the awarding agency will be calculated by applying the awarding agency's percentage of participation in the cost of the original purchase to the proceeds of the sale after deduction of any actual and reasonable selling and fixing-up expenses. If the grant is still active, the net proceeds from sale may be offset against the original cost of the property. When a grantee or subgrantee is directed to sell property, sales procedures shall be followed that provide for competition to the extent practicable and result in the highest possible return.

(3) *Transfer of title.* Transfer title to the awarding agency or to a third-party designated/approved by the awarding agency. The grantee or subgrantee shall be paid an amount calculated by applying the grantee or subgrantee's percentage of participation in the purchase of the real property to the current fair market value of the property.

**§ 1207.32 Equipment.**

(a) *Title.* Subject to the obligations and conditions set forth in this section, title to equipment acquired under a grant or subgrant will vest upon acquisition in the grantee or subgrantee respectively.

(b) *States.* A State will use, manage, and dispose of equipment acquired

under a grant by the State in accordance with State laws and procedures. Other grantees and subgrantees will follow paragraphs (c) through (e) of this section.

(c) *Use.* (1) Equipment shall be used by the grantee or subgrantee in the program or project for which it was acquired as long as needed, whether or not the project or program continues to be supported by Federal funds. When no longer needed for the original program or project, the equipment may be used in other activities currently or previously supported by a Federal agency.

(2) The grantee or subgrantee shall also make equipment available for use on other projects or programs currently or previously supported by the Federal Government, providing such use will not interfere with the work on the projects or program for which it was originally acquired. First preference for other use shall be given to other programs or projects supported by the awarding agency. User fees should be considered if appropriate.

(3) Notwithstanding the encouragement in §1207.25(a) to earn program income, the grantee or subgrantee must not use equipment acquired with grant funds to provide services for a fee to compete unfairly with private companies that provide equivalent services, unless specifically permitted or contemplated by Federal statute.

(4) When acquiring replacement equipment, the grantee or subgrantee may use the equipment to be replaced as a trade-in or sell the property and use the proceeds to offset the cost of the replacement property, subject to the approval of the awarding agency.

(d) *Management requirements.* Procedures for managing equipment (including replacement equipment), whether acquired in whole or in part with grant funds, until disposition takes place will, as a minimum, meet the following requirements:

(1) Property records must be maintained that include a description of the property, a serial number or other identification number, the source of property, who holds title, the acquisition date, and cost of the property, percentage of Federal participation in the cost of the property, the location, use



and condition of the property, and any ultimate disposition data including the date of disposal and sale price of the property.

(2) A physical inventory of the property must be taken and the results reconciled with the property records at least once every two years.

(3) A control system must be developed to ensure adequate safeguards to prevent loss, damage, or theft of the property. Any loss, damage, or theft shall be investigated.

(4) Adequate maintenance procedures must be developed to keep the property in good condition.

(5) If the grantee or subgrantee is authorized or required to sell the property, proper sales procedures must be established to ensure the highest possible return.

(e) *Disposition.* When original or replacement equipment acquired under a grant or subgrant is no longer needed for the original project or program or for other activities currently or previously supported by a Federal agency, disposition of the equipment will be made as follows:

(1) Items of equipment with a current per-unit fair market value of less than \$5,000 may be retained, sold or otherwise disposed of with no further obligation to the awarding agency.

(2) Items of equipment with a current per unit fair market value in excess of \$5,000 may be retained or sold and the awarding agency shall have a right to an amount calculated by multiplying the current market value or proceeds from sale by the awarding agency's share of the equipment.

(3) In cases where a grantee or subgrantee fails to take appropriate disposition actions, the awarding agency may direct the grantee or subgrantee to take excess and disposition actions.

(f) *Federal equipment.* In the event a grantee or subgrantee is provided federally-owned equipment:

(1) Title will remain vested in the Federal Government.

(2) Grantees or subgrantees will manage the equipment in accordance with Federal agency rules and procedures, and submit an annual inventory listing.

(3) When the equipment is no longer needed, the grantee or subgrantee will

request disposition instructions from the Federal agency.

(g) *Right to transfer title.* The Federal awarding agency may reserve the right to transfer title to the Federal Government or a third part named by the awarding agency when such a third party is otherwise eligible under existing statutes. Such transfers shall be subject to the following standards:

(1) The property shall be identified in the grant or otherwise made known to the grantee in writing.

(2) The Federal awarding agency shall issue disposition instruction within 120 calendar days after the end of the Federal support of the project for which it was acquired. If the Federal awarding agency fails to issue disposition instructions within the 120 calendar-day period the grantee shall follow §1207.32(e).

(3) When title to equipment is transferred, the grantee shall be paid an amount calculated by applying the percentage of participation in the purchase to the current fair market value of the property.

#### § 1207.33 Supplies.

(a) *Title.* Title to supplies acquired under a grant or subgrant will vest, upon acquisition, in the grantee or subgrantee respectively.

(b) *Disposition.* If there is a residual inventory of unused supplies exceeding \$5,000 in total aggregate fair market value upon termination or completion of the award, and if the supplies are not needed for any other federally sponsored programs or projects, the grantee or subgrantee shall compensate the awarding agency for its share.

#### § 1207.34 Copyrights.

The Federal awarding agency reserves a royalty-free, nonexclusive, and irrevocable license to reproduce, publish or otherwise use, and to authorize others to use, for Federal Government purposes:

(a) The copyright in any work developed under a grant, subgrant, or contract under a grant or subgrant; and

(b) Any rights of copyright to which a grantee, subgrantee or a contractor purchases ownership with grant support.

**§ 1207.35 Subawards to debarred and suspended parties.**

Grantees and subgrantees must not make any award or permit any award (subgrant or contract) at any tier to any party which is debarred or suspended or is otherwise excluded from or ineligible for participation in Federal assistance programs under Executive Order 12549, "Debarment and Suspension."

**§ 1207.36 Procurement.**

(a) *States.* When procuring property and services under a grant, a State will follow the same policies and procedures it uses for procurements from its non-Federal funds. The State will ensure that every purchase order or other contract includes any clauses required by Federal statutes and executive orders and their implementing regulations. Other grantees and subgrantees will follow paragraphs (b) through (i) in this section.

(b) *Procurement standards.* (1) Grantees and subgrantees will use their own procurement procedures which reflect applicable State and local laws and regulations, provided that the procurements conform to applicable Federal law and the standards identified in this section.

(2) Grantees and subgrantees will maintain a contract administration system which ensures that contractors perform in accordance with the terms, conditions, and specifications of their contracts or purchase orders.

(3) Grantees and subgrantees will maintain a written code of standards of conduct governing the performance of their employees engaged in the award and administration of contracts. No employee, officer or agent of the grantee or subgrantee shall participate in selection, or in the award or administration of a contract supported by Federal funds if a conflict of interest, real or apparent, would be involved. Such a conflict would arise when:

- (i) The employee, officer or agent,
- (ii) Any member of his immediate family,
- (iii) His or her partner, or
- (iv) An organization which employs, or is about to employ, any of the above, has a financial or other interest in the firm selected for award. The

grantee's or subgrantee's officers, employees or agents will neither solicit nor accept gratuities, favors or anything of monetary value from contractors, potential contractors, or parties to subagreements. Grantee and subgrantees may set minimum rules where the financial interest is not substantial or the gift is an unsolicited item of nominal intrinsic value. To the extent permitted by State or local law or regulations, such standards or conduct will provide for penalties, sanctions, or other disciplinary actions for violations of such standards by the grantee's and subgrantee's officers, employees, or agents, or by contractors or their agents. The awarding agency may in regulation provide additional prohibitions relative to real, apparent, or potential conflicts of interest.

(4) Grantee and subgrantee procedures will provide for a review of proposed procurements to avoid purchase of unnecessary or duplicative items. Consideration should be given to consolidating or breaking out procurements to obtain a more economical purchase. Where appropriate, an analysis will be made of lease versus purchase alternatives, and any other appropriate analysis to determine the most economical approach.

(5) To foster greater economy and efficiency, grantees and subgrantees are encouraged to enter into State and local intergovernmental agreements for procurement or use of common goods and services.

(6) Grantees and subgrantees are encouraged to use Federal excess and surplus property in lieu of purchasing new equipment and property whenever such use is feasible and reduces project costs.

(7) Grantees and subgrantees are encouraged to use value engineering clauses in contracts for construction projects of sufficient size to offer reasonable opportunities for cost reductions. Value engineering is a systematic and creative analysis of each contract item or task to ensure that its essential function is provided at the overall lower cost.

(8) Grantees and subgrantees will make awards only to responsible contractors possessing the ability to perform successfully under the terms and

conditions of a proposed procurement. Consideration will be given to such matters as contractor integrity, compliance with public policy, record of past performance, and financial and technical resources.

(9) Grantees and subgrantees will maintain records sufficient to detail the significant history of a procurement. These records will include, but are not necessarily limited to the following: rationale for the method of procurement, selection of contract type, contractor selection or rejection, and the basis for the contract price.

(10) Grantees and subgrantees will use time and material type contracts only—

(i) After a determination that no other contract is suitable, and

(ii) If the contract includes a ceiling price that the contractor exceeds at its own risk.

(11) Grantees and subgrantees alone will be responsible, in accordance with good administrative practice and sound business judgment, for the settlement of all contractual and administrative issues arising out of procurements. These issues include, but are not limited to source evaluation, protests, disputes, and claims. These standards do not relieve the grantee or subgrantee of any contractual responsibilities under its contracts. Federal agencies will not substitute their judgment for that of the grantee or subgrantee unless the matter is primarily a Federal concern. Violations of law will be referred to the local, State, or Federal authority having proper jurisdiction.

(12) Grantees and subgrantees will have protest procedures to handle and resolve disputes relating to their procurements and shall in all instances disclose information regarding the protest to the awarding agency. A protestor must exhaust all administrative remedies with the grantee and subgrantee before pursuing a protest with the Federal agency. Reviews of protests by the Federal agency will be limited to:

(i) Violations of Federal law or regulations and the standards of this section (violations of State or local law will be under the jurisdiction of State or local authorities) and

(ii) Violations of the grantee's or subgrantee's protest procedures for failure to review a complaint or protest. Protests received by the Federal agency other than those specified above will be referred to the grantee or subgrantee.

(c) *Competition.* (1) All procurement transactions will be conducted in a manner providing full and open competition consistent with the standards of § 1207.36. Some of the situations considered to be restrictive of competition include but are not limited to:

(i) Placing unreasonable requirements on firms in order for them to qualify to do business,

(ii) Requiring unnecessary experience and excessive bonding,

(iii) Noncompetitive pricing practices between firms or between affiliated companies,

(iv) Noncompetitive awards to consultants that are on retainer contracts,

(v) Organizational conflicts of interest,

(vi) Specifying only a "brand name" product instead of allowing "an equal" product to be offered and describing the performance of other relevant requirements of the procurement, and

(vii) Any arbitrary action in the procurement process.

(2) Grantees and subgrantees will conduct procurements in a manner that prohibits the use of statutorily or administratively imposed in-State or local geographical preferences in the evaluation of bids or proposals, except in those cases where applicable Federal statutes expressly mandate or encourage geographic preference. Nothing in this section preempts State licensing laws. When contracting for architectural and engineering (A/E) services, geographic location may be a selection criteria provided its application leaves an appropriate number of qualified firms, given the nature and size of the project, to compete for the contract.

(3) Grantees will have written selection procedures for procurement transactions. These procedures will ensure that all solicitations:

(i) Incorporate a clear and accurate description of the technical requirements for the material, product, or service to be procured. Such description shall not, in competitive procurements, contain features which unduly

restrict competition. The description may include a statement of the qualitative nature of the material, product or service to be procured, and when necessary, shall set forth those minimum essential characteristics and standards to which it must conform if it is to satisfy its intended use. Detailed product specifications should be avoided if at all possible. When it is impractical or uneconomical to make a clear and accurate description of the technical requirements, a "brand name or equal" description may be used as a means to define the performance or other salient requirements of a procurement. The specific features of the named brand which must be met by offerors shall be clearly stated; and

(ii) Identify all requirements which the offerors must fulfill and all other factors to be used in evaluating bids or proposals.

(4) Grantees and subgrantees will ensure that all prequalified lists of persons, firms, or products which are used in acquiring goods and services are current and include enough qualified sources to ensure maximum open and free competition. Also, grantees and subgrantees will not preclude potential bidders from qualifying during the solicitation period.

(d) *Methods of procurement to be followed*—(1) *Procurement by small purchase procedures*. Small purchase procedures are those relatively simple and informal procurement methods for securing services, supplies, or other property that do not cost more than the simplified acquisition threshold fixed at 41 U.S.C. 403(11) (currently set at \$100,000). If small purchase procedures are used, price or rate quotations shall be obtained from an adequate number of qualified sources.

(2) *Procurement by sealed bids* (formal advertising). Bids are publicly solicited and a firm-fixed-price contract (lump sum or unit price) is awarded to the responsible bidder whose bid, conforming with all the material terms and conditions of the invitation for bids, is the lowest in price. The sealed bid method is the preferred method for procuring construction, if the conditions in § 1207.36(d)(2)(i) apply.

(i) In order for sealed bidding to be feasible, the following conditions should be present:

(A) A complete, adequate, and realistic specification or purchase description is available;

(B) Two or more responsible bidders are willing and able to compete effectively and for the business; and

(C) The procurement lends itself to a firm fixed price contract and the selection of the successful bidder can be made principally on the basis of price.

(ii) If sealed bids are used, the following requirements apply:

(A) The invitation for bids will be publicly advertised and bids shall be solicited from an adequate number of known suppliers, providing them sufficient time prior to the date set for opening the bids;

(B) The invitation for bids, which will include any specifications and pertinent attachments, shall define the items or services in order for the bidder to properly respond;

(C) All bids will be publicly opened at the time and place prescribed in the invitation for bids;

(D) A firm fixed-price contract award will be made in writing to the lowest responsive and responsible bidder. Where specified in bidding documents, factors such as discounts, transportation cost, and life cycle costs shall be considered in determining which bid is lowest. Payment discounts will only be used to determine the low bid when prior experience indicates that such discounts are usually taken advantage of; and

(E) Any or all bids may be rejected if there is a sound documented reason.

(3) *Procurement by competitive proposals*. The technique of competitive proposals is normally conducted with more than one source submitting an offer, and either a fixed-price or cost-reimbursement type contract is awarded. It is generally used when conditions are not appropriate for the use of sealed bids. If this method is used, the following requirements apply:

(i) Requests for proposals will be publicized and identify all evaluation factors and their relative importance. Any response to publicized requests for proposals shall be honored to the maximum extent practical;

(ii) Proposals will be solicited from an adequate number of qualified sources;

(iii) Grantees and subgrantees will have a method for conducting technical evaluations of the proposals received and for selecting awardees;

(iv) Awards will be made to the responsible firm whose proposal is most advantageous to the program, with price and other factors considered; and

(v) Grantees and subgrantees may use competitive proposal procedures for qualifications-based procurement of architectural/engineering (A/E) professional services whereby competitors' qualifications are evaluated and the most qualified competitor is selected, subject to negotiation of fair and reasonable compensation. The method, where price is not used as a selection factor, can only be used in procurement of A/E professional services. It cannot be used to purchase other types of services though A/E firms are a potential source to perform the proposed effort.

(4) Procurement by *noncompetitive proposals* is procurement through solicitation of a proposal from only one source, or after solicitation of a number of sources, competition is determined inadequate.

(i) Procurement by noncompetitive proposals may be used only when the award of a contract is infeasible under small purchase procedures, sealed bids or competitive proposals and one of the following circumstances applies:

(A) The item is available only from a single source;

(B) The public exigency or emergency for the requirement will not permit a delay resulting from competitive solicitation;

(C) The awarding agency authorizes noncompetitive proposals; or

(D) After solicitation of a number of sources, competition is determined inadequate.

(ii) Cost analysis, i.e., verifying the proposed cost data, the projections of the data, and the evaluation of the specific elements of costs and profits, is required.

(iii) Grantees and subgrantees may be required to submit the proposed procurement to the awarding agency for

pre-award review in accordance with paragraph (g) of this section.

(e) *Contracting with small and minority firms, women's business enterprise and labor surplus area firms.* (1) The grantee and subgrantee will take all necessary affirmative steps to assure that minority firms, women's business enterprises, and labor surplus area firms are used when possible.

(2) Affirmative steps shall include:

(i) Placing qualified small and minority businesses and women's business enterprises on solicitation lists;

(ii) Assuring that small and minority businesses, and women's business enterprises are solicited whenever they are potential sources;

(iii) Dividing total requirements, when economically feasible, into smaller tasks or quantities to permit maximum participation by small and minority business, and women's business enterprises;

(iv) Establishing delivery schedules, where the requirement permits, which encourage participation by small and minority business, and women's business enterprises;

(v) Using the services and assistance of the Small Business Administration, and the Minority Business Development Agency of the Department of Commerce; and

(vi) Requiring the prime contractor, if subcontracts are to be let, to take the affirmative steps listed in paragraphs (e)(2)(i) through (v) of this section.

(f) *Contract cost and price.* (1) Grantees and subgrantees must perform a cost or price analysis in connection with every procurement action including contract modifications. The method and degree of analysis is dependent on the facts surrounding the particular procurement situation, but as a starting point, grantees must make independent estimates before receiving bids or proposals. A cost analysis must be performed when the offeror is required to submit the elements of his estimated cost, e.g., under professional, consulting, and architectural engineering services contracts. A cost analysis will be necessary when adequate price competition is lacking, and for sole source procurements, including contract modifications or change orders,

## § 1207.36

unless price reasonableness can be established on the basis of a catalog or market price of a commercial product sold in substantial quantities to the general public or based on prices set by law or regulation. A price analysis will be used in all other instances to determine the reasonableness of the proposed contract price.

(2) Grantees and subgrantees will negotiate profit as a separate element of the price for each contract in which there is no price competition and in all cases where cost analysis is performed. To establish a fair and reasonable profit, consideration will be given to the complexity of the work to be performed, the risk borne by the contractor, the contractor's investment, the amount of subcontracting, the quality of its record of past performance, and industry profit rates in the surrounding geographical area for similar work.

(3) Costs or prices based on estimated costs for contracts under grants will be allowable only to the extent that costs incurred or cost estimates included in negotiated prices are consistent with Federal cost principles (see § 1207.22). Grantees may reference their own cost principles that comply with the applicable Federal cost principles.

(4) The cost plus a percentage of cost and percentage of construction cost methods of contracting shall not be used.

(g) *Awarding agency review.* (1) Grantees and subgrantees must make available, upon request of the awarding agency, technical specifications on proposed procurements where the awarding agency believes such review is needed to ensure that the item and/or service specified is the one being proposed for purchase. This review generally will take place prior to the time the specification is incorporated into a solicitation document. However, if the grantee or subgrantee desires to have the review accomplished after a solicitation has been developed, the awarding agency may still review the specifications, with such review usually limited to the technical aspects of the proposed purchase.

(2) Grantees and subgrantees must on request make available for awarding agency pre-award review procurement

## 36 CFR Ch. XII (7-1-03 Edition)

documents, such as requests for proposals or invitations for bids, independent cost estimates, etc. when:

(i) A grantee's or subgrantee's procurement procedures or operation fails to comply with the procurement standards in this section; or

(ii) The procurement is expected to exceed the simplified acquisition threshold and is to be awarded without competition or only one bid or offer is received in response to a solicitation; or

(iii) The procurement, which is expected to exceed the simplified acquisition threshold, specifies a "brand name" product; or

(iv) The proposed award is more than the simplified acquisition threshold and is to be awarded to other than the apparent low bidder under a sealed bid procurement; or

(v) A proposed contract modification changes the scope of a contract or increases the contract amount by more than the simplified acquisition threshold.

(3) A grantee or subgrantee will be exempt from the pre-award review in paragraph (g)(2) of this section if the awarding agency determines that its procurement systems comply with the standards of this section.

(i) A grantee or subgrantee may request that its procurement system be reviewed by the awarding agency to determine whether its system meets these standards in order for its system to be certified. Generally, these reviews shall occur where there is a continuous high-dollar funding, and third-party contracts are awarded on a regular basis.

(ii) A grantee or subgrantee may self-certify its procurement system. Such self-certification shall not limit the awarding agency's right to survey the system. Under a self-certification procedure, awarding agencies may wish to rely on written assurances from the grantee or subgrantee that it is complying with these standards. A grantee or subgrantee will cite specific procedures, regulations, standards, etc., as being in compliance with these requirements and have its system available for review.

(h) *Bonding requirements.* For construction or facility improvement contracts or subcontracts exceeding the simplified acquisition threshold, the awarding agency may accept the bonding policy and requirements of the grantee or subgrantee provided the awarding agency has made a determination that the awarding agency's interest is adequately protected. If such a determination has not been made, the minimum requirements shall be as follows:

(1) *A bid guarantee from each bidder equivalent to five percent of the bid price.* The "bid guarantee" shall consist of a firm commitment such as a bid bond, certified check, or other negotiable instrument accompanying a bid as assurance that the bidder will, upon acceptance of his bid, execute such contractual documents as may be required within the time specified.

(2) *A performance bond on the part of the contractor for 100 percent of the contract price.* A "performance bond" is one executed in connection with a contract to secure fulfillment of all the contractor's obligations under such contract.

(3) *A payment bond on the part of the contractor for 100 percent of the contract price.* A "payment bond" is one executed in connection with a contract to assure payment as required by law of all persons supplying labor and material in the execution of the work provided for in the contract.

(i) *Contract provisions.* A grantee's and subgrantee's contracts must contain provisions in paragraph (i) of this section. Federal agencies are permitted to require changes, remedies, changed conditions, access and records retention, suspension of work, and other clauses approved by the Office of Federal Procurement Policy.

(1) Administrative, contractual, or legal remedies in instances where contractors violate or breach contract terms, and provide for such sanctions and penalties as may be appropriate. (Contracts more than the simplified acquisition threshold)

(2) Termination for cause and for convenience by the grantee or subgrantee including the manner by which it will be effected and the basis for set-

tlement. (All contracts in excess of \$10,000)

(3) Compliance with Executive Order 11246 of September 24, 1965, entitled "Equal Employment Opportunity," as amended by Executive Order 11375 of October 13, 1967, and as supplemented in Department of Labor regulations (41 CFR chapter 60). (All construction contracts awarded in excess of \$10,000 by grantees and their contractors or subgrantees)

(4) Compliance with the Copeland "Anti-Kickback" Act (18 U.S.C. 874) as supplemented in Department of Labor regulations (29 CFR Part 3). (All contracts and subgrants for construction or repair)

(5) Compliance with the Davis-Bacon Act (40 U.S.C. 276a to 276a-7) as supplemented by Department of Labor regulations (29 CFR Part 5). (Construction contracts in excess of \$2000 awarded by grantees and subgrantees when required by Federal grant program legislation)

(6) Compliance with Sections 103 and 107 of the Contract Work Hours and Safety Standards Act (40 U.S.C. 327-330) as supplemented by Department of Labor regulations (29 CFR Part 5). (Construction contracts awarded by grantees and subgrantees in excess of \$2000, and in excess of \$2500 for other contracts which involve the employment of mechanics or laborers)

(7) Notice of awarding agency requirements and regulations pertaining to reporting.

(8) Notice of awarding agency requirements and regulations pertaining to patent rights with respect to any discovery or invention which arises or is developed in the course of or under such contract.

(9) Awarding agency requirements and regulations pertaining to copyrights and rights in data.

(10) Access by the grantee, the subgrantee, the Federal grantor agency, the Comptroller General of the United States, or any of their duly authorized representatives to any books, documents, papers, and records of the contractor which are directly pertinent to that specific contract for the purpose of making audit, examination, excerpts, and transcriptions.

## § 1207.37

(11) Retention of all required records for three years after grantees or subgrantees make final payments and all other pending matters are closed.

(12) Compliance with all applicable standards, orders, or requirements issued under section 306 of the Clean Air Act (42 U.S.C. 1857(h)), section 508 of the Clean Water Act (33 U.S.C. 1368), Executive Order 11738, and Environmental Protection Agency regulations (40 CFR part 15). (Contracts, subcontracts, and subgrants of amounts in excess of \$100,000)

(13) Mandatory standards and policies relating to energy efficiency which are contained in the state energy conservation plan issued in compliance with the Energy Policy and Conservation Act (Pub. L. 94-163, 89 Stat. 871).

[53 FR 8072, Mar. 11, 1988, as amended at 60 FR 19639, 19643, Apr. 19, 1995]

### § 1207.37 Subgrants.

(a) *States.* States shall follow state law and procedures when awarding and administering subgrants (whether on a cost reimbursement or fixed amount basis) of financial assistance to local and Indian tribal governments. States shall:

(1) Ensure that every subgrant includes any clauses required by Federal statute and executive orders and their implementing regulations;

(2) Ensure that subgrantees are aware of requirements imposed upon them by Federal statute and regulation;

(3) Ensure that a provision for compliance with §1207.42 is placed in every cost reimbursement subgrant; and

(4) Conform any advances of grant funds to subgrantees substantially to the same standards of timing and amount that apply to cash advances by Federal agencies.

(b) *All other grantees.* All other grantees shall follow the provisions of this part which are applicable to awarding agencies when awarding and administering subgrants (whether on a cost reimbursement or fixed amount basis) of financial assistance to local and Indian tribal governments. Grantees shall:

(1) Ensure that every subgrant includes a provision for compliance with this part;

## 36 CFR Ch. XII (7-1-03 Edition)

(2) Ensure that every subgrant includes any clauses required by Federal statute and executive orders and their implementing regulations; and

(3) Ensure that subgrantees are aware of requirements imposed upon them by Federal statutes and regulations.

(c) *Exceptions.* By their own terms, certain provisions of this part do not apply to the award and administration of subgrants:

(1) Section 1207.10;

(2) Section 1207.11;

(3) The letter-of-credit procedures specified in Treasury Regulations at 31 CFR part 205, cited in § 1207.21; and

(4) Section 1207.50.

### REPORTS, RECORDS, RETENTION, AND ENFORCEMENT

### § 1207.40 Monitoring and reporting program performance.

(a) *Monitoring by grantees.* Grantees are responsible for managing the day-to-day operations of grant and subgrant supported activities. Grantees must monitor grant and subgrant supported activities to assure compliance with applicable Federal requirements and that performance goals are being achieved. Grantee monitoring must cover each program, function or activity.

(b) *Nonconstruction performance reports.* The Federal agency may, if it decides that performance information available from subsequent applications contains sufficient information to meet its programmatic needs, require the grantee to submit a performance report only upon expiration or termination of grant support. Unless waived by the Federal agency this report will be due on the same date as the final Financial Status Report.

(1) Grantees shall submit annual performance reports unless the awarding agency requires quarterly or semi-annual reports. However, performance reports will not be required more frequently than quarterly. Annual reports shall be due 90 days after the grant year, quarterly or semi-annual reports shall be due 30 days after the reporting period. The final performance report will be due 90 days after the expiration or termination of grant support. If a



justified request is submitted by a grantee, the Federal agency may extend the due date for any performance report. Additionally, requirements for unnecessary performance reports may be waived by the Federal agency.

(2) Performance reports will contain, for each grant, brief information on the following:

(i) A comparison of actual accomplishments to the objectives established for the period. Where the output of the project can be quantified, a computation of the cost per unit of output may be required if that information will be useful.

(ii) The reasons for slippage if established objectives were not met.

(iii) Additional pertinent information including, when appropriate, analysis and explanation of cost overruns or high unit costs.

(3) Grantees will not be required to submit more than the original and two copies of performance reports.

(4) Grantees will adhere to the standards in this section in prescribing performance reporting requirements for subgrantees.

(c) *Construction performance reports.* For the most part, on-site technical inspections and certified percentage-of-completion data are relied on heavily by Federal agencies to monitor progress under construction grants and subgrants. The Federal agency will require additional formal performance reports only when considered necessary, and never more frequently than quarterly.

(d) *Significant developments.* Events may occur between the scheduled performance reporting dates which have significant impact upon the grant or subgrant supported activity. In such cases, the grantee must inform the Federal agency as soon as the following types of conditions become known:

(1) Problems, delays, or adverse conditions which will materially impair the ability to meet the objective of the award. This disclosure must include a statement of the action taken, or contemplated, and any assistance needed to resolve the situation.

(2) Favorable developments which enable meeting time schedules and objectives sooner or at less cost than antici-

pated or producing more beneficial results than originally planned.

(e) Federal agencies may make site visits as warranted by program needs.

(f) *Waivers, extensions.* (1) Federal agencies may waive any performance report required by this part if not needed.

(2) The grantee may waive any performance report from a subgrantee when not needed. The grantee may extend the due date for any performance report from a subgrantee if the grantee will still be able to meet its performance reporting obligations to the Federal agency.

#### § 1207.41 Financial reporting.

(a) *General.* (1) Except as provided in paragraphs (a)(2) and (5) of this section, grantees will use only the forms specified in paragraphs (a) through (e) of this section, and such supplementary or other forms as may from time to time be authorized by OMB, for:

(i) Submitting financial reports to Federal agencies, or

(ii) Requesting advances or reimbursements when letters of credit are not used.

(2) Grantees need not apply the forms prescribed in this section in dealing with their subgrantees. However, grantees shall not impose more burdensome requirements on subgrantees.

(3) Grantees shall follow all applicable standard and supplemental Federal agency instructions approved by OMB to the extent required under the Paperwork Reduction Act of 1980 for use in connection with forms specified in paragraphs (b) through (e) of this section. Federal agencies may issue substantive supplementary instructions only with the approval of OMB. Federal agencies may shade out or instruct the grantee to disregard any line item that the Federal agency finds unnecessary for its decisionmaking purposes.

(4) Grantees will not be required to submit more than the original and two copies of forms required under this part.

(5) Federal agencies may provide computer outputs to grantees to expedite or contribute to the accuracy of reporting. Federal agencies may accept the required information from grantees

in machine usable format or computer printouts instead of prescribed forms.

(6) Federal agencies may waive any report required by this section if not needed.

(7) Federal agencies may extend the due date of any financial report upon receiving a justified request from a grantee.

(b) *Financial Status Report*—(1) *Form*. Grantees will use Standard Form 269 or 269A, Financial Status Report, to report the status of funds for all non-construction grants and for construction grants when required in accordance with § 1207.41(e)(2)(iii).

(2) *Accounting basis*. Each grantee will report program outlays and program income on a cash or accrual basis as prescribed by the awarding agency. If the Federal agency requires accrual information and the grantee's accounting records are not normally kept on the accrual basis, the grantee shall not be required to convert its accounting system but shall develop such accrual information through and analysis of the documentation on hand.

(3) *Frequency*. The Federal agency may prescribe the frequency of the report for each project or program. However, the report will not be required more frequently than quarterly. If the Federal agency does not specify the frequency of the report, it will be submitted annually. A final report will be required upon expiration or termination of grant support.

(4) *Due date*. When reports are required on a quarterly or semiannual basis, they will be due 30 days after the reporting period. When required on an annual basis, they will be due 90 days after the grant year. Final reports will be due 90 days after the expiration or termination of grant support.

(c) *Federal Cash Transactions Report*—(1) *Form*. (i) For grants paid by letter or credit, Treasury check advances or electronic transfer of funds, the grantee will submit the Standard Form 272, Federal Cash Transactions Report, and when necessary, its continuation sheet, Standard Form 272a, unless the terms of the award exempt the grantee from this requirement.

(ii) These reports will be used by the Federal agency to monitor cash advanced to grantees and to obtain dis-

bursement or outlay information for each grant from grantees. The format of the report may be adapted as appropriate when reporting is to be accomplished with the assistance of automatic data processing equipment provided that the information to be submitted is not changed in substance.

(2) *Forecasts of Federal cash requirements*. Forecasts of Federal cash requirements may be required in the "Remarks" section of the report.

(3) *Cash in hands of subgrantees*. When considered necessary and feasible by the Federal agency, grantees may be required to report the amount of cash advances in excess of three days' needs in the hands of their subgrantees or contractors and to provide short narrative explanations of actions taken by the grantee to reduce the excess balances.

(4) *Frequency and due date*. Grantees must submit the report no later than 15 working days following the end of each quarter. However, where an advance either by letter of credit or electronic transfer of funds is authorized at an annualized rate of one million dollars or more, the Federal agency may require the report to be submitted within 15 working days following the end of each month.

(d) *Request for advance or reimbursement*—(1) *Advance payments*. Requests for Treasury check advance payments will be submitted on Standard Form 270, Request for Advance or Reimbursement. (This form will not be used for drawdowns under a letter of credit, electronic funds transfer or when Treasury check advance payments are made to the grantee automatically on a predetermined basis.)

(2) *Reimbursements*. Requests for reimbursement under nonconstruction grants will also be submitted on Standard Form 270. (For reimbursement requests under construction grants, see paragraph (e)(1) of this section.)

(3) The frequency for submitting payment requests is treated in § 1207.41(b)(3).

(e) *Outlay report and request for reimbursement for construction programs*—(1) *Grants that support construction activities paid by reimbursement method*. (i) Requests for reimbursement under construction grants will be submitted on

Standard Form 271, Outlay Report and Request for Reimbursement for Construction Programs. Federal agencies may, however, prescribe the Request for Advance or Reimbursement form, specified in §1207.41(d), instead of this form.

(ii) The frequency for submitting reimbursement requests is treated in §1207.41(b)(3).

(2) *Grants that support construction activities paid by letter of credit, electronic funds transfer or Treasury check advance.* (i) When a construction grant is paid by letter of credit, electronic funds transfer or Treasury check advances, the grantee will report its outlays to the Federal agency using Standard Form 271, Outlay Report and Request for Reimbursement for Construction Programs. The Federal agency will provide any necessary special instruction. However, frequency and due date shall be governed by §1207.41(b)(3) and (4).

(ii) When a construction grant is paid by Treasury check advances based on periodic requests from the grantee, the advances will be requested on the form specified in §1207.41(d).

(iii) The Federal agency may substitute the Financial Status Report specified in §1207.41(b) for the Outlay Report and Request for Reimbursement for Construction Programs.

(3) *Accounting basis.* The accounting basis for the Outlay Report and Request for Reimbursement for Construction Programs shall be governed by §1207.41(b)(2).

#### § 1207.42 Retention and access requirements for records.

(a) *Applicability.* (1) This section applies to all financial and programmatic records, supporting documents, statistical records, and other records of grantees or subgrantees which are:

(i) Required to be maintained by the terms of this part, program regulations or the grant agreement, or

(ii) Otherwise reasonably considered as pertinent to program regulations or the grant agreement.

(2) This section does not apply to records maintained by contractors or subcontractors. For a requirement to place a provision concerning records in

certain kinds of contracts, see §1207.36(i)(10).

(b) *Length of retention period.* (1) Except as otherwise provided, records must be retained for three years from the starting date specified in paragraph (c) of this section.

(2) If any litigation, claim, negotiation, audit or other action involving the records has been started before the expiration of the 3-year period, the records must be retained until completion of the action and resolution of all issues which arise from it, or until the end of the regular 3-year period, whichever is later.

(3) To avoid duplicate recordkeeping, awarding agencies may make special arrangements with grantees and subgrantees to retain any records which are continuously needed for joint use. The awarding agency will request transfer of records to its custody when it determines that the records possess long-term retention value. When the records are transferred to or maintained by the Federal agency, the 3-year retention requirement is not applicable to the grantee or subgrantee.

(c) *Starting date of retention period—*(1) *General.* When grant support is continued or renewed at annual or other intervals, the retention period for the records of each funding period starts on the day the grantee or subgrantee submits to the awarding agency its single or last expenditure report for that period. However, if grant support is continued or renewed quarterly, the retention period for each year's records starts on the day the grantee submits its expenditure report for the last quarter of the Federal fiscal year. In all other cases, the retention period starts on the day the grantee submits its final expenditure report. If an expenditure report has been waived, the retention period starts on the day the report would have been due.

(2) *Real property and equipment records.* The retention period for real property and equipment records starts from the date of the disposition or replacement or transfer at the direction of the awarding agency.

(3) *Records for income transactions after grant or subgrant support.* In some cases grantees must report income after the period of grant support.

§ 1207.43

36 CFR Ch. XII (7-1-03 Edition)

Where there is such a requirement, the retention period for the records pertaining to the earning of the income starts from the end of the grantee's fiscal year in which the income is earned.

(4) *Indirect cost rate proposals, cost allocations plans, etc.* This paragraph applies to the following types of documents, and their supporting records: indirect cost rate computations or proposals, cost allocation plans, and any similar accounting computations of the rate at which a particular group of costs is chargeable (such as computer usage chargeback rates or composite fringe benefit rates).

(i) *If submitted for negotiation.* If the proposal, plan, or other computation is required to be submitted to the Federal Government (or to the grantee) to form the basis for negotiation of the rate, then the 3-year retention period for its supporting records starts from the date of such submission.

(ii) *If not submitted for negotiation.* If the proposal, plan, or other computation is not required to be submitted to the Federal Government (or to the grantee) for negotiation purposes, then the 3-year retention period for the proposal plan, or computation and its supporting records starts from end of the fiscal year (or other accounting period) covered by the proposal, plan, or other computation.

(d) *Substitution of microfilm.* Copies made by microfilming, photocopying, or similar methods may be substituted for the original records.

(e) *Access to records*—(1) *Records of grantees and subgrantees.* The awarding agency and the Comptroller General of the United States, or any of their authorized representatives, shall have the right of access to any pertinent books, documents, papers, or other records of grantees and subgrantees which are pertinent to the grant, in order to make audits, examinations, excerpts, and transcripts.

(2) *Expiration of right of access.* The rights of access in this section must not be limited to the required retention period but shall last as long as the records are retained.

(f) *Restrictions on public access.* The Federal Freedom of Information Act (5 U.S.C. 552) does not apply to records Unless required by Federal, State, or

local law, grantees and subgrantees are not required to permit public access to their records.

§ 1207.43 Enforcement.

(a) *Remedies for noncompliance.* If a grantee or subgrantee materially fails to comply with any term of an award, whether stated in a Federal statute or regulation, an assurance, in a State plan or application, a notice of award, or elsewhere, the awarding agency may take one or more of the following actions, as appropriate in the circumstances:

(1) Temporarily withhold cash payments pending correction of the deficiency by the grantee or subgrantee or more severe enforcement action by the awarding agency,

(2) Disallow (that is, deny both use of funds and matching credit for) all or part of the cost of the activity or action not in compliance,

(3) Wholly or partly suspend or terminate the current award for the grantee's or subgrantee's program,

(4) Withhold further awards for the program, or

(5) Take other remedies that may be legally available.

(b) *Hearings, appeals.* In taking an enforcement action, the awarding agency will provide the grantee or subgrantee an opportunity for such hearing, appeal, or other administrative proceeding to which the grantee or subgrantee is entitled under any statute or regulation applicable to the action involved.

(c) *Effects of suspension and termination.* Costs of grantee or subgrantee resulting from obligations incurred by the grantee or subgrantee during a suspension or after termination of an award are not allowable unless the awarding agency expressly authorizes them in the notice of suspension or termination or subsequently. Other grantee or subgrantee costs during suspension or after termination which are necessary and not reasonably avoidable are allowable if:

(1) The costs result from obligations which were properly incurred by the grantee or subgrantee before the effective date of suspension or termination, are not in anticipation of it, and, in the

case of a termination, are noncancellable, and,

(2) The costs would be allowable if the award were not suspended or expired normally at the end of the funding period in which the termination takes effect.

(d) *Relationship to debarment and suspension.* The enforcement remedies identified in this section, including suspension and termination, do not preclude grantee or subgrantee from being subject to “Debarment and Suspension” under E.O. 12549 (see § 1207.35).

#### § 1207.44 Termination for convenience.

Except as provided in § 1207.43 awards may be terminated in whole or in part only as follows:

(a) By the awarding agency with the consent of the grantee or subgrantee in which case the two parties shall agree upon the termination conditions, including the effective date and in the case of partial termination, the portion to be terminated, or

(b) By the grantee or subgrantee upon written notification to the awarding agency, setting forth the reasons for such termination, the effective date, and in the case of partial termination, the portion to be terminated. However, if, in the case of a partial termination, the awarding agency determines that the remaining portion of the award will not accomplish the purposes for which the award was made, the awarding agency may terminate the award in its entirety under either § 1207.43 or paragraph (a) of this section.

### Subpart D—After-The-Grant Requirements

#### § 1207.50 Closeout.

(a) *General.* The Federal agency will close out the award when it determines that all applicable administrative actions and all required work of the grant has been completed.

(b) *Reports.* Within 90 days after the expiration or termination of the grant, the grantee must submit all financial, performance, and other reports required as a condition of the grant. Upon request by the grantee, Federal agencies may extend this timeframe.

These may include but are not limited to:

(1) Final performance or progress report.

(2) Financial Status Report (SF 269) or Outlay Report and Request for Reimbursement for Construction Programs (SF-271) (as applicable).

(3) Final request for payment (SF-270) (if applicable).

(4) Invention disclosure (if applicable).

(5) Federally-owned property report:

In accordance with § 1207.32(f), a grantee must submit an inventory of all federally owned property (as distinct from property acquired with grant funds) for which it is accountable and request disposition instructions from the Federal agency of property no longer needed.

(c) *Cost adjustment.* The Federal agency will, within 90 days after receipt of reports in paragraph (b) of this section, make upward or downward adjustments to the allowable costs.

(d) *Cash adjustments.* (1) The Federal agency will make prompt payment to the grantee for allowable reimbursable costs.

(2) The grantee must immediately refund to the Federal agency any balance of unobligated (unencumbered) cash advanced that is not authorized to be retained for use on other grants.

#### § 1207.51 Later disallowances and adjustments.

The closeout of a grant does not affect:

(a) The Federal agency’s right to disallow costs and recover funds on the basis of a later audit or other review;

(b) The grantee’s obligation to return any funds due as a result of later refunds, corrections, or other transactions;

(c) Records retention as required in § 1207.42;

(d) Property management requirements in §§ 1207.31 and 1207.32; and

(e) Audit requirements in § 1207.26.

#### § 1207.52 Collection of amounts due.

(a) Any funds paid to a grantee in excess of the amount to which the grantee is finally determined to be entitled under the terms of the award constitute a debt to the Federal Government. If not paid within a reasonable

period after demand, the Federal agency may reduce the debt by:

(1) Making an administrative offset against other requests for reimbursements,

(2) Withholding advance payments otherwise due to the grantee, or

(3) Other action permitted by law.

(b) Except where otherwise provided by statutes or regulations, the Federal agency will charge interest on an overdue debt in accordance with the Federal Claims Collection Standards (4 CFR chapter II). The date from which interest is computed is not extended by litigation or the filing of any form of appeal.

#### Subpart E—Entitlement [Reserved]

### PART 1208—ENFORCEMENT OF NONDISCRIMINATION ON THE BASIS OF HANDICAP IN PROGRAMS OR ACTIVITIES CONDUCTED BY THE NATIONAL ARCHIVES AND RECORDS ADMINISTRATION

#### Sec.

- 1208.101 Purpose.
- 1208.102 Application.
- 1208.103 Definitions.
- 1208.104–1208.109 [Reserved]
- 1208.110 Self-evaluation.
- 1208.111 Notice.
- 1208.112–1208.129 [Reserved]
- 1208.130 General prohibitions against discrimination.
- 1208.131–1208.139 [Reserved]
- 1208.140 Employment.
- 1208.141–1208.148 [Reserved]
- 1208.149 Program accessibility: Discrimination prohibited.
- 1208.150 Program accessibility: Existing facilities.
- 1208.151 Program accessibility: New construction and alterations.
- 1208.152–1208.159 [Reserved]
- 1208.160 Communications.
- 1208.161–1208.169 [Reserved]
- 1208.170 Compliance procedures.
- 1208.171–1208.999 [Reserved]

AUTHORITY: 29 U.S.C. 794.

SOURCE: 53 FR 25884, 25885, July 8, 1988, unless otherwise noted.

#### § 1208.101 Purpose.

The purpose of this regulation is to effectuate section 119 of the Rehabilitation, Comprehensive Services, and

Developmental Disabilities Amendments of 1978, which amended section 504 of the Rehabilitation Act of 1973 to prohibit discrimination on the basis of handicap in programs or activities conducted by Executive agencies or the United States Postal Service.

#### § 1208.102 Application.

This regulation (§§ 1208.101–1208.170) applies to all programs or activities conducted by the agency, except for programs or activities conducted outside the United States that do not involve individuals with handicaps in the United States.

#### § 1208.103 Definitions.

For purposes of this regulation, the term—

*Assistant Attorney General* means the Assistant Attorney General, Civil Rights Division, United States Department of Justice.

*Auxiliary aids* means services or devices that enable persons with impaired sensory, manual, or speaking skills to have an equal opportunity to participate in, and enjoy the benefits of, programs or activities conducted by the agency. For example, auxiliary aids useful for persons with impaired vision include readers, Brailled materials, audio recordings, and other similar services and devices. Auxiliary aids useful for persons with impaired hearing include telephone handset amplifiers, telephones compatible with hearing aids, telecommunication devices for deaf persons (TDD's), interpreters, notetakers, written materials, and other similar services and devices.

*Complete complaint* means a written statement that contains the complainant's name and address and describes the agency's alleged discriminatory action in sufficient detail to inform the agency of the nature and date of the alleged violation of section 504. It shall be signed by the complainant or by someone authorized to do so on his or her behalf. Complaints filed on behalf of classes or third parties shall describe or identify (by name, if possible) the alleged victims of discrimination.

*Facility* means all or any portion of buildings, structures, equipment, roads, walks, parking lots, rolling

stock or other conveyances, or other real or personal property.

*Historic preservation programs* means programs conducted by the agency that have preservation of historic properties as a primary purpose.

*Historic properties* means those properties that are listed or eligible for listing in the National Register of Historic Places or properties designated as historic under a statute of the appropriate State or local government body.

*Individual with handicaps* means any person who has a physical or mental impairment that substantially limits one or more major life activities, has a record of such an impairment, or is regarded as having such an impairment.

As used in this definition, the phrase:

(1) *Physical or mental impairment* includes—

(i) Any physiological disorder or condition, cosmetic disfigurement, or anatomical loss affecting one or more of the following body systems: Neurological; musculoskeletal; special sense organs; respiratory, including speech organs; cardiovascular; reproductive; digestive; genitourinary; hemic and lymphatic; skin; and endocrine; or

(ii) Any mental or psychological disorder, such as mental retardation, organic brain syndrome, emotional or mental illness, and specific learning disabilities. The term *physical or mental impairment* includes, but is not limited to, such diseases and conditions as orthopedic, visual, speech, and hearing impairments, cerebral palsy, epilepsy, muscular dystrophy, multiple sclerosis, cancer, heart disease, diabetes, mental retardation, emotional illness, and drug addiction and alcoholism.

(2) *Major life activities* includes functions such as caring for one's self, performing manual tasks, walking, seeing, hearing, speaking, breathing, learning, and working.

(3) *Has a record of such an impairment* means has a history of, or has been misclassified as having, a mental or physical impairment that substantially limits one or more major life activities.

(4) *Is regarded as having an impairment* means—

(i) Has a physical or mental impairment that does not substantially limit major life activities but is treated by

the agency as constituting such a limitation;

(ii) Has a physical or mental impairment that substantially limits major life activities only as a result of the attitudes of others toward such impairment; or

(iii) Has none of the impairments defined in paragraph (i) of this definition but is treated by the agency as having such an impairment.

*Qualified individual with handicaps* means—

(1) With respect to preschool, elementary, or secondary education services provided by the agency, an individual with handicaps who is a member of a class of persons otherwise entitled by statute, regulation, or agency policy to receive education services from the agency;

(2) With respect to any other agency program or activity under which a person is required to perform services or to achieve a level of accomplishment, an individual with handicaps who meets the essential eligibility requirements and who can achieve the purpose of the program or activity without modifications in the program or activity that the agency can demonstrate would result in a fundamental alteration in its nature;

(3) With respect to any other program or activity, an individual with handicaps who meets the essential eligibility requirements for participation in, or receipt of benefits from, that program or activity; and

(4) *Qualified handicapped person* as that term is defined for purposes of employment in 29 CFR 1613.702(f), which is made applicable to this regulation by §1208.140.

*Section 504* means section 504 of the Rehabilitation Act of 1973 (Pub. L. 93-112, 87 Stat. 394 (29 U.S.C. 794)), as amended by the Rehabilitation Act Amendments of 1974 (Pub. L. 93-516, 88 Stat. 1617); the Rehabilitation, Comprehensive Services, and Developmental Disabilities Amendments of 1978 (Pub. L. 95-602, 92 Stat. 2955); and the Rehabilitation Act Amendments of 1986 (Pub. L. 99-506, 100 Stat. 1810). As used in this regulation, section 504 applies only to programs or activities conducted by Executive agencies and not to federally assisted programs.

*Substantial impairment* means a significant loss of the integrity of finished materials, design quality, or special character resulting from a permanent alteration.

§§ 1208.104–1208.109 [Reserved]

§ 1208.110 **Self-evaluation.**

(a) The agency shall, by September 6, 1989, evaluate its current policies and practices, and the effects thereof, that do not or may not meet the requirements of this regulation and, to the extent modification of any such policies and practices is required, the agency shall proceed to make the necessary modifications.

(b) The agency shall provide an opportunity to interested persons, including individuals with handicaps or organizations representing individuals with handicaps, to participate in the self-evaluation process by submitting comments (both oral and written).

(c) The agency shall, for at least three years following completion of the self-evaluation, maintain on file and make available for public inspection:

- (1) A description of areas examined and any problems identified; and
- (2) A description of any modifications made.

§ 1208.111 **Notice.**

The agency shall make available to employees, applicants, participants, beneficiaries, and other interested persons such information regarding the provisions of this regulation and its applicability to the programs or activities conducted by the agency, and make such information available to them in such manner as the head of the agency finds necessary to apprise such persons of the protections against discrimination assured them by section 504 and this regulation.

§§ 1208.112–1208.129 [Reserved]

§ 1208.130 **General prohibitions against discrimination.**

(a) No qualified individual with handicaps shall, on the basis of handicap, be excluded from participation in, be denied the benefits of, or otherwise be subjected to discrimination under

any program or activity conducted by the agency.

(b)(1) The agency, in providing any aid, benefit, or service, may not, directly or through contractual, licensing, or other arrangements, on the basis of handicap—

(i) Deny a qualified individual with handicaps the opportunity to participate in or benefit from the aid, benefit, or service;

(ii) Afford a qualified individual with handicaps an opportunity to participate in or benefit from the aid, benefit, or service that is not equal to that afforded others;

(iii) Provide a qualified individual with handicaps with an aid, benefit, or service that is not as effective in affording equal opportunity to obtain the same result, to gain the same benefit, or to reach the same level of achievement as that provided to others;

(iv) Provide different or separate aid, benefits, or services to individuals with handicaps or to any class of individuals with handicaps than is provided to others unless such action is necessary to provide qualified individuals with handicaps with aid, benefits, or services that are as effective as those provided to others;

(v) Deny a qualified individual with handicaps the opportunity to participate as a member of planning or advisory boards;

(vi) Otherwise limit a qualified individual with handicaps in the enjoyment of any right, privilege, advantage, or opportunity enjoyed by others receiving the aid, benefit, or service.

(2) The agency may not deny a qualified individual with handicaps the opportunity to participate in programs or activities that are not separate or different, despite the existence of permissibly separate or different programs or activities.

(3) The agency may not, directly or through contractual or other arrangements, utilize criteria or methods of administration the purpose or effect of which would—

(i) Subject qualified individuals with handicaps to discrimination on the basis of handicap; or

(ii) Defeat or substantially impair accomplishment of the objectives of a



program or activity with respect to individuals with handicaps.

(4) The agency may not, in determining the site or location of a facility, make selections the purpose or effect of which would—

(i) Exclude individuals with handicaps from, deny them the benefits of, or otherwise subject them to discrimination under any program or activity conducted by the agency; or

(ii) Defeat or substantially impair the accomplishment of the objectives of a program or activity with respect to individuals with handicaps.

(5) The agency, in the selection of procurement contractors, may not use criteria that subject qualified individuals with handicaps to discrimination on the basis of handicap.

(6) The agency may not administer a licensing or certification program in a manner that subjects qualified individuals with handicaps to discrimination on the basis of handicap, nor may the agency establish requirements for the programs or activities of licensees or certified entities that subject qualified individuals with handicaps to discrimination on the basis of handicap. However, the programs or activities of entities that are licensed or certified by the agency are not, themselves, covered by this regulation.

(c) The exclusion of nonhandicapped persons from the benefits of a program limited by Federal statute or Executive order to individuals with handicaps or the exclusion of a specific class of individuals with handicaps from a program limited by Federal statute or Executive order to a different class of individuals with handicaps is not prohibited by this regulation.

(d) The agency shall administer programs and activities in the most integrated setting appropriate to the needs of qualified individuals with handicaps.

**§§ 1208.131–1208.139 [Reserved]**

**§ 1208.140 Employment.**

No qualified individual with handicaps shall, on the basis of handicap, be subject to discrimination in employment under any program or activity conducted by the agency. The definitions, requirements, and procedures of section 501 of the Rehabilitation Act of

1973 (29 U.S.C. 791), as established by the Equal Employment Opportunity Commission in 29 CFR part 1613, shall apply to employment in federally conducted programs or activities.

**§ 1208.141–1208.148 [Reserved]**

**§ 1208.149 Program accessibility: Discrimination prohibited.**

Except as otherwise provided in § 1208.150, no qualified individual with handicaps shall, because the agency's facilities are inaccessible to or unusable by individuals with handicaps, be denied the benefits of, be excluded from participation in, or otherwise be subjected to discrimination under any program or activity conducted by the agency.

**§ 1208.150 Program accessibility: Existing facilities.**

(a) *General.* The agency shall operate each program or activity so that the program or activity, when viewed in its entirety, is readily accessible to and usable by individuals with handicaps. This paragraph does not—

(1) Necessarily require the agency to make each of its existing facilities accessible to and usable by individuals with handicaps;

(2) In the case of historic preservation programs, require the agency to take any action that would result in a substantial impairment of significant historic features of an historic property; or

(3) Require the agency to take any action that it can demonstrate would result in a fundamental alteration in the nature of a program or activity or in undue financial and administrative burdens. In those circumstances where agency personnel believe that the proposed action would fundamentally alter the program or activity or would result in undue financial and administrative burdens, the agency has the burden of proving that compliance with § 1208.150(a) would result in such alteration or burdens. The decision that compliance would result in such alteration or burdens must be made by the agency head or his or her designee after considering all agency resources available for use in the funding and operation of the conducted program or

activity, and must be accompanied by a written statement of the reasons for reaching that conclusion. If an action would result in such an alteration or such burdens, the agency shall take any other action that would not result in such an alteration or such burdens but would nevertheless ensure that individuals with handicaps receive the benefits and services of the program or activity.

(b) *Methods*—(1) *General*. The agency may comply with the requirements of this section through such means as redesign of equipment, reassignment of services to accessible buildings, assignment of aides to beneficiaries, home visits, delivery of services at alternate accessible sites, alteration of existing facilities and construction of new facilities, use of accessible rolling stock, or any other methods that result in making its programs or activities readily accessible to and usable by individuals with handicaps. The agency is not required to make structural changes in existing facilities where other methods are effective in achieving compliance with this section. The agency, in making alterations to existing buildings, shall meet accessibility requirements to the extent compelled by the Architectural Barriers Act of 1968, as amended (42 U.S.C. 4151-4157), and any regulations implementing it. In choosing among available methods for meeting the requirements of this section, the agency shall give priority to those methods that offer programs and activities to qualified individuals with handicaps in the most integrated setting appropriate.

(2) *Historic preservation programs*. In meeting the requirements of § 1208.150(a) in historic preservation programs, the agency shall give priority to methods that provide physical access to individuals with handicaps. In cases where a physical alteration to an historic property is not required because of § 1208.150(a)(2) or (3), alternative methods of achieving program accessibility include—

(i) Using audio-visual materials and devices to depict those portions of an historic property that cannot otherwise be made accessible;

(ii) Assigning persons to guide individuals with handicaps into or through

portions of historic properties that cannot otherwise be made accessible; or

(iii) Adopting other innovative methods.

(c) *Time period for compliance*. The agency shall comply with the obligations established under this section by November 7, 1988, except that where structural changes in facilities are undertaken, such changes shall be made by September 6, 1991, but in any event as expeditiously as possible.

(d) *Transition plan*. In the event that structural changes to facilities will be undertaken to achieve program accessibility, the agency shall develop, by March 6, 1989, a transition plan setting forth the steps necessary to complete such changes. The agency shall provide an opportunity to interested persons, including individuals with handicaps or organizations representing individuals with handicaps, to participate in the development of the transition plan by submitting comments (both oral and written). A copy of the transition plan shall be made available for public inspection. The plan shall, at a minimum—

(1) Identify physical obstacles in the agency's facilities that limit the accessibility of its programs or activities to individuals with handicaps;

(2) Describe in detail the methods that will be used to make the facilities accessible;

(3) Specify the schedule for taking the steps necessary to achieve compliance with this section and, if the time period of the transition plan is longer than one year, identify steps that will be taken during each year of the transition period; and

(4) Indicate the official responsible for implementation of the plan.

**§ 1208.151 Program accessibility: New construction and alterations.**

Each building or part of a building that is constructed or altered by, on behalf of, or for the use of the agency shall be designed, constructed, or altered so as to be readily accessible to and usable by individuals with handicaps. The definitions, requirements, and standards of the Architectural Barriers Act (42 U.S.C. 4151-4157), as established in 41 CFR 101-19.600 to 101-19.607,

apply to buildings covered by this section.

**§§ 1208.152–1208.159 [Reserved]**

**§ 1208.160 Communications.**

(a) The agency shall take appropriate steps to ensure effective communication with applicants, participants, personnel of other Federal entities, and members of the public.

(1) The agency shall furnish appropriate auxiliary aids where necessary to afford an individual with handicaps an equal opportunity to participate in, and enjoy the benefits of, a program or activity conducted by the agency.

(i) In determining what type of auxiliary aid is necessary, the agency shall give primary consideration to the requests of the individual with handicaps.

(ii) The agency need not provide individually prescribed devices, readers for personal use or study, or other devices of a personal nature.

(2) Where the agency communicates with applicants and beneficiaries by telephone, telecommunication devices for deaf persons (TDD's) or equally effective telecommunication systems shall be used to communicate with persons with impaired hearing.

(b) The agency shall ensure that interested persons, including persons with impaired vision or hearing, can obtain information as to the existence and location of accessible services, activities, and facilities.

(c) The agency shall provide signage at a primary entrance to each of its inaccessible facilities, directing users to a location at which they can obtain information about accessible facilities. The international symbol for accessibility shall be used at each primary entrance of an accessible facility.

(d) This section does not require the agency to take any action that it can demonstrate would result in a fundamental alteration in the nature of a program or activity or in undue financial and administrative burdens. In those circumstances where agency personnel believe that the proposed action would fundamentally alter the program or activity or would result in undue financial and administrative burdens, the agency has the burden of proving

that compliance with §1208.160 would result in such alteration or burdens. The decision that compliance would result in such alteration or burdens must be made by the agency head or his or her designee after considering all agency resources available for use in the funding and operation of the conducted program or activity and must be accompanied by a written statement of the reasons for reaching that conclusion. If an action required to comply with this section would result in such an alteration or such burdens, the agency shall take any other action that would not result in such an alteration or such burdens but would nevertheless ensure that, to the maximum extent possible, individuals with handicaps receive the benefits and services of the program or activity.

**§§ 1208.161–1208.169 [Reserved]**

**§ 1208.170 Compliance procedures.**

(a) Except as provided in paragraph (b) of this section, this section applies to all allegations of discrimination on the basis of handicap in programs and activities conducted by the agency.

(b) The agency shall process complaints alleging violations of section 504 with respect to employment according to the procedures established by the Equal Employment Opportunity Commission in 29 CFR part 1613 pursuant to section 501 of the Rehabilitation Act of 1973 (29 U.S.C. 791).

(c) The Assistant Archivist for Management and Administration shall be responsible for coordinating implementation of this section. Compliants may be sent to National Archives and Records Administration (NA), Washington, DC 20408.

(d) The agency shall accept and investigate all complete complaints for which it has jurisdiction. All complete complaints must be filed within 180 days of the alleged act of discrimination. The agency may extend this time period for good cause.

(e) If the agency receives a complaint over which it does not have jurisdiction, it shall promptly notify the complainant and shall make reasonable efforts to refer the complaint to the appropriate Government entity.

§§ 1208.171–1208.999

36 CFR Ch. XII (7–1–03 Edition)

(f) The agency shall notify the Architectural and Transportation Barriers Compliance Board upon receipt of any complaint alleging that a building or facility that is subject to the Architectural Barriers Act of 1968, as amended (42 U.S.C. 4151–4157), is not readily accessible to and usable by individuals with handicaps.

(g) Within 180 days of the receipt of a complete complaint for which it has jurisdiction, the agency shall notify the complainant of the results of the investigation in a letter containing—

(1) Findings of fact and conclusions of law;

(2) A description of a remedy for each violation found; and

(3) A notice of the right to appeal.

(h) Appeals of the findings of fact and conclusions of law or remedies must be filed by the complainant within 90 days of receipt from the agency of the letter required by §1208.170(g). The agency may extend this time for good cause.

(i) Timely appeals shall be accepted and processed by the head of the agency.

(j) The head of the agency shall notify the complainant of the results of the appeal within 60 days of the receipt of the request. If the head of the agency determines that additional information is needed from the complainant, he or she shall have 60 days from the date of receipt of the additional information to make his or her determination on the appeal.

(k) The time limits cited in paragraphs (g) and (j) of this section may be extended with the permission of the Assistant Attorney General.

(l) The agency may delegate its authority for conducting complaint investigations to other Federal agencies, except that the authority for making the final determination may not be delegated to another agency.

[53 FR 25884, 25885, July 8, 1988, as amended at 53 FR 25884, July 8, 1988]

§§ 1208.171–1208.999 [Reserved]

**PART 1209—GOVERNMENTWIDE DEBARMENT AND SUSPENSION (NONPROCUREMENT) AND GOVERNMENTWIDE REQUIREMENTS FOR DRUG-FREE WORKPLACE (GRANTS)**

**Subpart A—General**

Sec.

- 1209.100 Purpose.
- 1209.105 Definitions.
- 1209.110 Coverage.
- 1209.115 Policy.

**Subpart B—Effect of Action**

- 1209.200 Debarment or suspension.
- 1209.205 Ineligible persons.
- 1209.210 Voluntary exclusion.
- 1209.215 Exception provision.
- 1209.220 Continuation of covered transactions.
- 1209.225 Failure to adhere to restrictions.

**Subpart C—Debarment**

- 1209.300 General.
- 1209.305 Causes for debarment.
- 1209.310 Procedures.
- 1209.311 Investigation and referral.
- 1209.312 Notice of proposed debarment.
- 1209.313 Opportunity to contest proposed debarment.
- 1209.314 Debarring official's decision.
- 1209.315 Settlement and voluntary exclusion.
- 1209.320 Period of debarment.
- 1209.325 Scope of debarment.

**Subpart D—Suspension**

- 1209.400 General.
- 1209.405 Causes for suspension.
- 1209.410 Procedures.
- 1209.411 Notice of suspension.
- 1209.412 Opportunity to contest suspension.
- 1209.413 Suspending official's decision.
- 1209.415 Period of suspension.
- 1209.420 Scope of suspension.

**Subpart E—Responsibilities of GSA, Agency and Participants**

- 1209.500 GSA responsibilities.
- 1209.505 NARA responsibilities.
- 1209.510 Participant's responsibilities.

### Subpart F—Drug-Free Workplace Requirements (Grants)

- 1209.600 Purpose.  
 1209.605 Definitions.  
 1209.610 Coverage.  
 1209.615 Grounds for suspension of payments, suspension or termination of grants, or suspension or debarment.  
 1209.620 Effect of violation.  
 1209.625 Exception provision.  
 1209.630 Certification requirements and procedures.  
 1209.635 Reporting of and employee sanctions for convictions of criminal drug offenses.

APPENDIX A TO PART 1209—CERTIFICATION REGARDING DEBARMENT, SUSPENSION, AND OTHER RESPONSIBILITY MATTERS—PRIMARY COVERED TRANSACTIONS

APPENDIX B TO PART 1209—CERTIFICATION REGARDING DEBARMENT, SUSPENSION, INELIGIBILITY AND VOLUNTARY EXCLUSION—LOWER TIER COVERED TRANSACTIONS

APPENDIX C TO PART 1209—CERTIFICATION REGARDING DRUG-FREE WORKPLACE REQUIREMENTS

AUTHORITY: E.O. 12549; sec. 5151–5160 of the Drug-Free Workplace Act of 1988 (Pub. L. 100–690, title V, subtitle D; 41 U.S.C. 701 *et seq.*); 44 U.S.C. 2104(a).

SOURCE: 53 FR 19193, 19194, 19204, May 26, 1988, unless otherwise noted.

CROSS REFERENCE: See also Office of Management and Budget notice published at 55 FR 21679, May 25, 1990, and 60 FR 33036, June 26, 1995.

### Subpart A—General

#### § 1209.100 Purpose.

(a) Executive Order (E.O.) 12549 provides that, to the extent permitted by law, Executive departments and agencies shall participate in a governmentwide system for nonprocurement debarment and suspension. A person who is debarred or suspended shall be excluded from Federal financial and non-financial assistance and benefits under Federal programs and activities. Debarment or suspension of a participant in a program by one agency shall have governmentwide effect.

(b) These regulations implement section 3 of E.O. 12549 and the guidelines promulgated by the Office of Management and Budget under section 6 of the E.O. by:

(1) Prescribing the programs and activities that are covered by the governmentwide system;

(2) Prescribing the governmentwide criteria and governmentwide minimum due process procedures that each agency shall use;

(3) Providing for the listing of debarred and suspended participants, participants declared ineligible (see definition of “ineligible” in § 1209.105), and participants who have voluntarily excluded themselves from participation in covered transactions;

(4) Setting forth the consequences of a debarment, suspension, determination of ineligibility, or voluntary exclusion; and

(5) Offering such other guidance as necessary for the effective implementation and administration of the governmentwide system.

(c) These regulations also implement Executive Order 12689 (3 CFR, 1989 Comp., p. 235) and 31 U.S.C. 6101 note (Public Law 103–355, sec. 2455, 108 Stat. 3327) by—

(1) Providing for the inclusion in the *List of Parties Excluded from Federal Procurement and Nonprocurement Programs* all persons proposed for debarment, debarred or suspended under the Federal Acquisition Regulation, 48 CFR Part 9, subpart 9.4; persons against which governmentwide exclusions have been entered under this part; and persons determined to be ineligible; and

(2) Setting forth the consequences of a debarment, suspension, determination of ineligibility, or voluntary exclusion.

(d) Although these regulations cover the listing of ineligible participants and the effect of such listing, they do not prescribe policies and procedures governing declarations of ineligibility.

[60 FR 33040, 33058, June 26, 1995]

#### § 1209.105 Definitions.

The following definitions apply to this part:

*Adequate evidence.* Information sufficient to support the reasonable belief that a particular act or omission has occurred.

*Affiliate.* Persons are affiliates of each other if, directly or indirectly, either one controls or has the power to control the other, *or*, a third person controls or has the power to control both. Indicia of control include, but are

not limited to: interlocking management or ownership, identity of interests among family members, shared facilities and equipment, common use of employees, or a business entity organized following the suspension or debarment of a person which has the same or similar management, ownership, or principal employees as the suspended, debarred, ineligible, or voluntarily excluded person.

*Agency.* Any executive department, military department or defense agency or other agency of the executive branch, excluding the independent regulatory agencies.

*Civil judgment.* The disposition of a civil action by any court of competent jurisdiction, whether entered by verdict, decision, settlement, stipulation, or otherwise creating a civil liability for the wrongful acts complained of; or a final determination of liability under the Program Fraud Civil Remedies Act of 1988 (31 U.S.C. 3801-3812).

*Conviction.* A judgment or conviction of a criminal offense by any court of competent jurisdiction, whether entered upon a verdict or a plea, including a plea of nolo contendere.

*Debarment.* An action taken by a debarring official in accordance with these regulations to exclude a person from participating in covered transactions. A person so excluded is "debarred."

*Debarring official.* An official authorized to impose debarment. The debarring official is either:

- (1) The agency head, or
- (2) An official designated by the agency head.

*Indictment.* Indictment for a criminal offense. An information or other filing by competent authority charging a criminal offense shall be given the same effect as an indictment.

*Ineligible.* Excluded from participation in Federal nonprocurement programs pursuant to a determination of ineligibility under statutory, executive order, or regulatory authority, other than Executive Order 12549 and its agency implementing regulations; for example, excluded pursuant to the Davis-Bacon Act and its implementing regulations, the equal employment opportunity acts and executive orders, or the environmental protection acts and

executive orders. A person is ineligible where the determination of ineligibility affects such person's eligibility to participate in more than one covered transaction.

*Legal proceedings.* Any criminal proceeding or any civil judicial proceeding to which the Federal Government or a State or local government or quasi-governmental authority is a party. The term includes appeals from such proceedings.

*List of Parties Excluded from Federal Procurement and Nonprocurement Programs.* A list compiled, maintained and distributed by the General Services Administration (GSA) containing the names and other information about persons who have been debarred, suspended, or voluntarily excluded under Executive Orders 12549 and 12689 and these regulations or 48 CFR part 9, subpart 9.4, persons who have been proposed for debarment under 48 CFR part 9, subpart 9.4, and those persons who have been determined to be ineligible.

*Notice.* A written communication served in person or sent by certified mail, return receipt requested, or its equivalent, to the last known address of a party, its identified counsel, its agent for service of process, or any partner, officer, director, owner, or joint venturer of the party. Notice, if undeliverable, shall be considered to have been received by the addressee five days after being properly sent to the last address known by the agency.

*Participant.* Any person who submits a proposal for, enters into, or reasonably may be expected to enter into a covered transaction. This term also includes any person who acts on behalf of or is authorized to commit a participant in a covered transaction as an agent or representative of another participant.

*Person.* Any individual, corporation, partnership, association, unit of government or legal entity, however organized, except: foreign governments or foreign governmental entities, public international organizations, foreign government owned (in whole or in part) or controlled entities, and entities consisting wholly or partially of foreign governments or foreign governmental entities.

*Preponderance of the evidence.* Proof by information that, compared with that opposing it, leads to the conclusion that the fact at issue is more probably true than not.

*Principal.* Officer, director, owner, partner, key employee, or other person within a participant with primary management or supervisory responsibilities; or a person who has a critical influence on or substantive control over a covered transaction, whether or not employed by the participant. Persons who have a critical influence on or substantive control over a covered transaction are:

(1) Principal investigators.

*Proposal.* A solicited or unsolicited bid, application, request, invitation to consider or similar communication by or on behalf of a person seeking to participate or to receive a benefit, directly or indirectly, in or under a covered transaction.

*Respondent.* A person against whom a debarment or suspension action has been initiated.

*State.* Any of the States of the United States, the District of Columbia, the Commonwealth of Puerto Rico, any territory or possession of the United States, or any agency of a State, exclusive of institutions of higher education, hospitals, and units of local government. A State instrumentality will be considered part of the State government if it has a written determination from a State government that such State considers that instrumentality to be an agency of the State government.

*Suspending official.* An official authorized to impose suspension. The suspending official is either:

(1) The agency head, or

(2) An official designated by the agency head.

*Suspension.* An action taken by a suspending official in accordance with these regulations that immediately excludes a person from participating in covered transactions for a temporary period, pending completion of an investigation and such legal, debarment, or Program Fraud Civil Remedies Act proceedings as may ensue. A person so excluded is "suspended."

*Voluntary exclusion or voluntarily excluded.* A status of nonparticipation or

limited participation in covered transactions assumed by a person pursuant to the terms of a settlement.

*NARA.* National Archives and Records Administration.

[53 FR 19193, 19194, 19204, May 26, 1988, as amended at 60 FR 33040, 33058, June 26, 1995]

#### § 1209.110 Coverage.

(a) These regulations apply to all persons who have participated, are currently participating or may reasonably be expected to participate in transactions under Federal nonprocurement programs. For purposes of these regulations such transactions will be referred to as "covered transactions."

(1) *Covered transaction.* For purposes of these regulations, a covered transaction is a primary covered transaction or a lower tier covered transaction. Covered transactions at any tier need not involve the transfer of Federal funds.

(i) *Primary covered transaction.* Except as noted in paragraph (a)(2) of this section, a primary covered transaction is any nonprocurement transaction between an agency and a person, regardless of type, including: grants, cooperative agreements, scholarships, fellowships, contracts of assistance, loans, loan guarantees, subsidies, insurance, payments for specified use, donation agreements and any other nonprocurement transactions between a Federal agency and a person. Primary covered transactions also include those transactions specially designated by the U.S. Department of Housing and Urban Development in such agency's regulations governing debarment and suspension.

(ii) *Lower tier covered transaction.* A lower tier covered transaction is:

(A) Any transaction between a participant and a person other than a procurement contract for goods or services, regardless of type, under a primary covered transaction.

(B) Any procurement contract for goods or services between a participant and a person, regardless of type, expected to equal or exceed the Federal procurement small purchase threshold fixed at 10 U.S.C. 2304(g) and 41 U.S.C. 253(g) (currently \$25,000) under a primary covered transaction.

§ 1209.115

36 CFR Ch. XII (7-1-03 Edition)

(C) Any procurement contract for goods or services between a participant and a person under a covered transaction, regardless of amount, under which that person will have a critical influence on or substantive control over that covered transaction. Such persons are:

(1) Principal investigators.

(2) Providers of federally-required audit services.

(2) *Exceptions.* The following transactions are not covered:

(i) Statutory entitlements or mandatory awards (but not subtier awards thereunder which are not themselves mandatory), including deposited funds insured by the Federal Government;

(ii) Direct awards to foreign governments or public international organizations, or transactions with foreign governments or foreign governmental entities, public international organizations, foreign government owned (in whole or in part) or controlled entities, entities consisting wholly or partially of foreign governments or foreign governmental entities;

(iii) Benefits to an individual as a personal entitlement without regard to the individual's present responsibility (but benefits received in an individual's business capacity are not excepted);

(iv) Federal employment;

(v) Transactions pursuant to national or agency-recognized emergencies or disasters;

(vi) Incidental benefits derived from ordinary governmental operations; and

(vii) Other transactions where the application of these regulations would be prohibited by law.

(b) *Relationship to other sections.* This section describes the types of transactions to which a debarment or suspension under the regulations will apply. Subpart B, "Effect of Action," § 1209.200, "Debarment or suspension," sets forth the consequences of a debarment or suspension. Those consequences would obtain only with respect to participants and principals in the covered transactions and activities described in § 1209.110(a). Sections 1209.325, "Scope of debarment," and 1209.420, "Scope of suspension," govern the extent to which a specific participant or organizational elements of a

participant would be automatically included within a debarment or suspension action, and the conditions under which affiliates or persons associated with a participant may also be brought within the scope of the action.

(c) *Relationship to Federal procurement activities.* In accordance with E.O. 12689 and section 2455 of Public Law 103-355, any debarment, suspension, proposed debarment or other governmentwide exclusion initiated under the Federal Acquisition Regulation (FAR) on or after August 25, 1995 shall be recognized by and effective for Executive Branch agencies and participants as an exclusion under this regulation. Similarly, any debarment, suspension or other governmentwide exclusion initiated under this regulation on or after August 25, 1995 shall be recognized by and effective for those agencies as a debarment or suspension under the FAR.

[53 FR 19193, 19194, 19204, May 26, 1988, as amended at 60 FR 33041, 33058, June 26, 1995]

§ 1209.115 Policy.

(a) In order to protect the public interest, it is the policy of the Federal Government to conduct business only with responsible persons. Debarment and suspension are discretionary actions that, taken in accordance with Executive Order 12549 and these regulations, are appropriate means to implement this policy.

(b) Debarment and suspension are serious actions which shall be used only in the public interest and for the Federal Government's protection and not for purposes of punishment. Agencies may impose debarment or suspension for the causes and in accordance with the procedures set forth in these regulations.

(c) When more than one agency has an interest in the proposed debarment or suspension of a person, consideration shall be given to designating one agency as the lead agency for making the decision. Agencies are encouraged to establish methods and procedures for coordinating their debarment or suspension actions.



**Subpart B—Effect of Action****§ 1209.200 Debarment or suspension.**

(a) *Primary covered transactions.* Except to the extent prohibited by law, persons who are debarred or suspended shall be excluded from primary covered transactions as either participants or principals throughout the Executive Branch of the Federal Government for the period of their debarment, suspension, or the period they are proposed for debarment under 48 CFR part 9, subpart 9.4. Accordingly, no agency shall enter into primary covered transactions with such excluded persons during such period, except as permitted pursuant to § 1209.215.

(b) *Lower tier covered transactions.* Except to the extent prohibited by law, persons who have been proposed for debarment under 48 CFR part 9, subpart 9.4, debarred or suspended shall be excluded from participating as either participants or principals in all lower tier covered transactions (see § 1209.110(a)(1)(ii)) for the period of their exclusion.

(c) *Exceptions.* Debarment or suspension does not affect a person's eligibility for—

(1) Statutory entitlements or mandatory awards (but not subtier awards thereunder which are not themselves mandatory), including deposited funds insured by the Federal Government;

(2) Direct awards to foreign governments or public international organizations, or transactions with foreign governments or foreign governmental entities, public international organizations, foreign government owned (in whole or in part) or controlled entities, and entities consisting wholly or partially of foreign governments or foreign governmental entities;

(3) Benefits to an individual as a personal entitlement without regard to the individual's present responsibility (but benefits received in an individual's business capacity are not excepted);

(4) Federal employment;

(5) Transactions pursuant to national or agency-recognized emergencies or disasters;

(6) Incidental benefits derived from ordinary governmental operations; and

(7) Other transactions where the application of these regulations would be prohibited by law.

[60 FR 33041, 33058, June 26, 1995]

**§ 1209.205 Ineligible persons.**

Persons who are ineligible, as defined in § 1209.105(i), are excluded in accordance with the applicable statutory, executive order, or regulatory authority.

**§ 1209.210 Voluntary exclusion.**

Persons who accept voluntary exclusions under § 1209.315 are excluded in accordance with the terms of their settlements. NARA shall, and participants may, contact the original action agency to ascertain the extent of the exclusion.

**§ 1209.215 Exception provision.**

NARA may grant an exception permitting a debarred, suspended, or voluntarily excluded person, or a person proposed for debarment under 48 CFR part 9, subpart 9.4, to participate in a particular covered transaction upon a written determination by the agency head or an authorized designee stating the reason(s) for deviating from the Presidential policy established by Executive Order 12549 and § 1209.200. However, in accordance with the President's stated intention in the Executive Order, exceptions shall be granted only infrequently. Exceptions shall be reported in accordance with § 1209.505(a).

[60 FR 33041, 33058, June 26, 1995]

**§ 1209.220 Continuation of covered transactions.**

(a) Notwithstanding the debarment, suspension, proposed debarment under 48 CFR part 9, subpart 9.4, determination of ineligibility, or voluntary exclusion of any person by an agency, agencies and participants may continue covered transactions in existence at the time the person was debarred, suspended, proposed for debarment under 48 CFR part 9, subpart 9.4, declared ineligible, or voluntarily excluded. A decision as to the type of termination action, if any, to be taken should be made only after thorough review to ensure the propriety of the proposed action.

## § 1209.225

(b) Agencies and participants shall not renew or extend covered transactions (other than no-cost time extensions) with any person who is debarred, suspended, proposed for debarment under 48 CFR part 9, subpart 9.4, ineligible or voluntarily excluded, except as provided in § 1209.215.

[60 FR 33041, 33058, June 26, 1995]

### § 1209.225 Failure to adhere to restrictions.

(a) Except as permitted under § 1209.215 or § 1209.220, a participant shall not knowingly do business under a covered transaction with a person who is—

(1) Debarred or suspended;

(2) Proposed for debarment under 48 CFR part 9, subpart 9.4; or

(3) Ineligible for or voluntarily excluded from the covered transaction.

(b) Violation of the restriction under paragraph (a) of this section may result in disallowance of costs, annulment or termination of award, issuance of a stop work order, debarment or suspension, or other remedies as appropriate.

(c) A participant may rely upon the certification of a prospective participant in a lower tier covered transaction that it and its principals are not debarred, suspended, proposed for debarment under 48 CFR part 9, subpart 9.4, ineligible, or voluntarily excluded from the covered transaction (See Appendix B of these regulations), unless it knows that the certification is erroneous. An agency has the burden of proof that a participant did knowingly do business with a person that filed an erroneous certification.

[60 FR 33041, 33058, June 26, 1995]

## Subpart C—Debarment

### § 1209.300 General.

The debarring official may debar a person for any of the causes in § 1209.305, using procedures established in §§ 1209.310 through 1209.314. The existence of a cause for debarment, however, does not necessarily require that the person be debarred; the seriousness of the person's acts or omissions and any mitigating factors shall be consid-

## 36 CFR Ch. XII (7-1-03 Edition)

ered in making any debarment decision.

### § 1209.305 Causes for debarment.

Debarment may be imposed in accordance with the provisions of §§ 1209.300 through 1209.314 for:

(a) Conviction of or civil judgment for:

(1) Commission of fraud or a criminal offense in connection with obtaining, attempting to obtain, or performing a public or private agreement or transaction;

(2) Violation of Federal or State anti-trust statutes, including those proscribing price fixing between competitors, allocation of customers between competitors, and bid rigging;

(3) Commission of embezzlement, theft, forgery, bribery, falsification or destruction of records, making false statements, receiving stolen property, making false claims, or obstruction of justice; or

(4) Commission of any other offense indicating a lack of business integrity or business honesty that seriously and directly affects the present responsibility of a person.

(b) Violation of the terms of a public agreement or transaction so serious as to affect the integrity of an agency program, such as:

(1) A willful failure to perform in accordance with the terms of one or more public agreements or transactions;

(2) A history of failure to perform or of unsatisfactory performance of one or more public agreements or transactions; or

(3) A willful violation of a statutory or regulatory provision or requirement applicable to a public agreement or transaction.

(c) Any of the following causes:

(1) A nonprocurement debarment by any Federal agency taken before October 1, 1988, the effective date of these regulations, or a procurement debarment by any Federal agency taken pursuant to 48 CFR subpart 9.4;

(2) Knowingly doing business with a debarred, suspended, ineligible, or voluntarily excluded person, in connection with a covered transaction, except as permitted in § 1209.215 or § 1209.220;

(3) Failure to pay a single substantial debt, or a number of outstanding debts

(including disallowed costs and overpayments, but not including sums owed the Federal Government under the Internal Revenue Code) owed to any Federal agency or instrumentality, provided the debt is uncontested by the debtor or, if contested, provided that the debtor's legal and administrative remedies have been exhausted;

(4) Violation of a material provision of a voluntary exclusion agreement entered into under § 1209.315 or of any settlement of a debarment or suspension action; or

(5) Violation of any requirement of subpart F of this part, relating to providing a drug-free workplace, as set forth in § 1209.615 of this part.

(d) Any other cause of so serious or compelling a nature that it affects the present responsibility of a person.

[53 FR 19193, 19194, 19204, May 26, 1988, as amended at 54 FR 4950, 4961, Jan. 31, 1989]

#### § 1209.310 Procedures.

NARA shall process debarment actions as informally as practicable, consistent with the principles of fundamental fairness, using the procedures in §§ 1209.311 through 1209.314.

#### § 1209.311 Investigation and referral.

Information concerning the existence of a cause for debarment from any source shall be promptly reported, investigated, and referred, when appropriate, to the debarring official for consideration. After consideration, the debarring official may issue a notice of proposed debarment.

#### § 1209.312 Notice of proposed debarment.

A debarment proceeding shall be initiated by notice to the respondent advising:

(a) That debarment is being considered;

(b) Of the reasons for the proposed debarment in terms sufficient to put the respondent on notice of the conduct or transaction(s) upon which it is based;

(c) Of the cause(s) relied upon under § 1209.305 for proposing debarment;

(d) Of the provisions of § 1209.311 through § 1209.314, and any other NARA procedures, if applicable, governing debarment decisionmaking; and

(e) Of the potential effect of a debarment.

#### § 1209.313 Opportunity to contest proposed debarment.

(a) *Submission in opposition.* Within 30 days after receipt of the notice of proposed debarment, the respondent may submit, in person, in writing, or through a representative, information and argument in opposition to the proposed debarment.

(b) *Additional proceedings as to disputed material facts.* (1) In actions not based upon a conviction or civil judgment, if the debarring official finds that the respondent's submission in opposition raises a genuine dispute over facts material to the proposed debarment, respondent(s) shall be afforded an opportunity to appear with a representative, submit documentary evidence, present witnesses, and confront any witness the agency presents.

(2) A transcribed record of any additional proceedings shall be made available at cost to the respondent, upon request, unless the respondent and the agency, by mutual agreement, waive the requirement for a transcript.

#### § 1209.314 Debarring official's decision.

(a) *No additional proceedings necessary.* In actions based upon a conviction or civil judgment, or in which there is no genuine dispute over material facts, the debarring official shall make a decision on the basis of all the information in the administrative record, including any submission made by the respondent. The decision shall be made within 45 days after receipt of any information and argument submitted by the respondent, unless the debarring official extends this period for good cause.

(b) *Additional proceedings necessary.* (1) In actions in which additional proceedings are necessary to determine disputed material facts, written findings of fact shall be prepared. The debarring official shall base the decision on the facts as found, together with any information and argument submitted by the respondent and any other information in the administrative record.

**§ 1209.315**

(2) The debarring official may refer disputed material facts to another official for findings of fact. The debarring official may reject any such findings, in whole or in part, only after specifically determining them to be arbitrary and capricious or clearly erroneous.

(3) The debarring official's decision shall be made after the conclusion of the proceedings with respect to disputed facts.

(c)(1) *Standard of proof.* In any debarment action, the cause for debarment must be established by a preponderance of the evidence. Where the proposed debarment is based upon a conviction or civil judgment, the standard shall be deemed to have been met.

(2) *Burden of proof.* The burden of proof is on the agency proposing debarment.

(d) *Notice of debarring official's decision.* (1) If the debarring official decides to impose debarment, the respondent shall be given prompt notice:

(i) Referring to the notice of proposed debarment;

(ii) Specifying the reasons for debarment;

(iii) Stating the period of debarment, including effective dates; and

(iv) Advising that the debarment is effective for covered transactions throughout the executive branch of the Federal Government unless an agency head or an authorized designee makes the determination referred to in §1209.215.

(2) If the debarring official decides not to impose debarment, the respondent shall be given prompt notice of that decision. A decision not to impose debarment shall be without prejudice to a subsequent imposition of debarment by any other agency.

**§ 1209.315 Settlement and voluntary exclusion.**

(a) When in the best interest of the Government, NARA may, at any time, settle a debarment or suspension action.

(b) If a participant and the agency agree to a voluntary exclusion of the participant, such voluntary exclusion shall be entered on the Nonprocurement List (see subpart E).

**36 CFR Ch. XII (7-1-03 Edition)**

**§ 1209.320 Period of debarment.**

(a) Debarment shall be for a period commensurate with the seriousness of the cause(s). If a suspension precedes a debarment, the suspension period shall be considered in determining the debarment period.

(1) Debarment for causes other than those related to a violation of the requirements of subpart F of this part generally should not exceed three years. Where circumstances warrant, a longer period of debarment may be imposed.

(2) In the case of a debarment for a violation of the requirements of subpart F of this part (see §1209.305(c)(5)), the period of debarment shall not exceed five years.

(b) The debarring official may extend an existing debarment for an additional period, if that official determines that an extension is necessary to protect the public interest. However, a debarment may not be extended solely on the basis of the facts and circumstances upon which the initial debarment action was based. If debarment for an additional period is determined to be necessary, the procedures of §§1209.311 through 1209.314 shall be followed to extend the debarment.

(c) The respondent may request the debarring official to reverse the debarment decision or to reduce the period or scope of debarment. Such a request shall be in writing and supported by documentation. The debarring official may grant such a request for reasons including, but not limited to:

(1) Newly discovered material evidence;

(2) Reversal of the conviction or civil judgment upon which the debarment was based;

(3) Bona fide change in ownership or management;

(4) Elimination of other causes for which the debarment was imposed; or

(5) Other reasons the debarring official deems appropriate.

[53 FR 19193, 19194, 19204, May 26, 1988, as amended at 54 FR 4950, 4961, Jan. 31, 1989]

**§ 1209.325 Scope of debarment.**

(a) *Scope in general.* (1) Debarment of a person under these regulations constitutes debarment of all its divisions

and other organizational elements from all covered transactions, unless the debarment decision is limited by its terms to one or more specifically identified individuals, divisions or other organizational elements or to specific types of transactions.

(2) The debarment action may include any affiliate of the participant that is specifically named and given notice of the proposed debarment and an opportunity to respond (see §§ 1209.311 through 1209.314).

(b) *Imputing conduct.* For purposes of determining the scope of debarment, conduct may be imputed as follows:

(1) *Conduct imputed to participant.* The fraudulent, criminal or other seriously improper conduct of any officer, director, shareholder, partner, employee, or other individual associated with a participant may be imputed to the participant when the conduct occurred in connection with the individual's performance of duties for or on behalf of the participant, or with the participant's knowledge, approval, or acquiescence. The participant's acceptance of the benefits derived from the conduct shall be evidence of such knowledge, approval, or acquiescence.

(2) *Conduct imputed to individuals associated with participant.* The fraudulent, criminal, or other seriously improper conduct of a participant may be imputed to any officer, director, shareholder, partner, employee, or other individual associated with the participant who participated in, knew of, or had reason to know of the participant's conduct.

(3) *Conduct of one participant imputed to other participants in a joint venture.* The fraudulent, criminal, or other seriously improper conduct of one participant in a joint venture, grant pursuant to a joint application, or similar arrangement may be imputed to other participants if the conduct occurred for or on behalf of the joint venture, grant pursuant to a joint application, or similar arrangement may be imputed to other participants if the conduct occurred for or on behalf of the joint venture, grant pursuant to a joint application, or similar arrangement or with the knowledge, approval, or acquiescence of these participants. Acceptance of the benefits derived from the con-

duct shall be evidence of such knowledge, approval, or acquiescence.

### Subpart D—Suspension

#### § 1209.400 General.

(a) The suspending official may suspend a person for any of the causes in § 1209.405 using procedures established in §§ 1209.410 through 1209.413.

(b) Suspension is a serious action to be imposed only when:

(1) There exists adequate evidence of one or more of the causes set out in § 1209.405, and

(2) Immediate action is necessary to protect the public interest.

(c) In assessing the adequacy of the evidence, the agency should consider how much information is available, how credible it is given the circumstances, whether or not important allegations are corroborated, and what inferences can reasonably be drawn as a result. This assessment should include an examination of basic documents such as grants, cooperative agreements, loan authorizations, and contracts.

#### § 1209.405 Causes for suspension.

(a) Suspension may be imposed in accordance with the provisions of §§ 1209.400 through 1209.413 upon adequate evidence:

(1) To suspect the commission of an offense listed in § 1209.305(a); or

(2) That a cause for debarment under § 1209.305 may exist.

(b) Indictment shall constitute adequate evidence for purposes of suspension actions.

#### § 1209.410 Procedures.

(a) *Investigation and referral.* Information concerning the existence of a cause for suspension from any source shall be promptly reported, investigated, and referred, when appropriate, to the suspending official for consideration. After consideration, the suspending official may issue a notice of suspension.

(b) *Decisionmaking process.* NARA shall process suspension actions as informally as practicable, consistent with principles of fundamental fairness, using the procedures in § 1209.411 through § 1209.413.

## § 1209.411

### § 1209.411 Notice of suspension.

When a respondent is suspended, notice shall immediately be given:

(a) That suspension has been imposed;

(b) That the suspension is based on an indictment, conviction, or other adequate evidence that the respondent has committed irregularities seriously reflecting on the propriety of further Federal Government dealings with the respondent;

(c) Describing any such irregularities in terms sufficient to put the respondent on notice without disclosing the Federal Government's evidence;

(d) Of the cause(s) relied upon under § 1209.405 for imposing suspension;

(e) That the suspension is for a temporary period pending the completion of an investigation or ensuing legal, debarment, or Program Fraud Civil Remedies Act proceedings;

(f) Of the provisions of § 1209.411 through § 1209.413 and any other NARA procedures, if applicable, governing suspension decisionmaking; and

(g) Of the effect of the suspension.

### § 1209.412 Opportunity to contest suspension.

(a) *Submission in opposition.* Within 30 days after receipt of the notice of suspension, the respondent may submit, in person, in writing, or through a representative, information and argument in opposition to the suspension.

(b) *Additional proceedings as to disputed material facts.* (1) If the suspending official finds that the respondent's submission in opposition raises a genuine dispute over facts material to the suspension, respondent(s) shall be afforded an opportunity to appear with a representative, submit documentary evidence, present witnesses, and confront any witness the agency presents, unless:

(i) The action is based on an indictment, conviction or civil judgment, or

(ii) A determination is made, on the basis of Department of Justice advice, that the substantial interests of the Federal Government in pending or contemplated legal proceedings based on the same facts as the suspension would be prejudiced.

(2) A transcribed record of any additional proceedings shall be prepared

## 36 CFR Ch. XII (7-1-03 Edition)

and made available at cost to the respondent, upon request, unless the respondent and the agency, by mutual agreement, waive the requirement for a transcript.

### § 1209.413 Suspending official's decision.

The suspending official may modify or terminate the suspension (for example, see § 1209.320(c) for reasons for reducing the period or scope of debarment) or may leave it in force. However, a decision to modify or terminate the suspension shall be without prejudice to the subsequent imposition of suspension by any other agency or debarment by any agency. The decision shall be rendered in accordance with the following provisions:

(a) *No additional proceedings necessary.* In actions: based on an indictment, conviction, or civil judgment; in which there is no genuine dispute over material facts; or in which additional proceedings to determine disputed material facts have been denied on the basis of Department of Justice advice, the suspending official shall make a decision on the basis of all the information in the administrative record, including any submission made by the respondent. The decision shall be made within 45 days after receipt of any information and argument submitted by the respondent, unless the suspending official extends this period for good cause.

(b) *Additional proceedings necessary.* (1) In actions in which additional proceedings are necessary to determine disputed material facts, written findings of fact shall be prepared. The suspending official shall base the decision on the facts as found, together with any information and argument submitted by the respondent and any other information in the administrative record.

(2) The suspending official may refer matters involving disputed material facts to another official for findings of fact. The suspending official may reject any such findings, in whole or in part, only after specifically determining them to be arbitrary or capricious or clearly erroneous.

(c) *Notice of suspending official's decision.* Prompt written notice of the suspending official's decision shall be sent to the respondent.

**§ 1209.415 Period of suspension.**

(a) Suspension shall be for a temporary period pending the completion of an investigation or ensuing legal, debarment, or Program Fraud Civil Remedies Act proceedings, unless terminated sooner by the suspending official or as provided in paragraph (b) of this section.

(b) If legal or administrative proceedings are not initiated within 12 months after the date of the suspension notice, the suspension shall be terminated unless an Assistant Attorney General or United States Attorney requests its extension in writing, in which case it may be extended for an additional six months. In no event may a suspension extend beyond 18 months, unless such proceedings have been initiated within that period.

(c) The suspending official shall notify the Department of Justice of an impending termination of a suspension, at least 30 days before the 12-month period expires, to give that Department an opportunity to request an extension.

**§ 1209.420 Scope of suspension.**

The scope of a suspension is the same as the scope of a debarment (see § 1209.325), except that the procedures of §§ 1209.410 through 1209.413 shall be used in imposing a suspension.

**Subpart E—Responsibilities of GSA, Agency and Participants**

**§ 1209.500 GSA responsibilities.**

(a) In accordance with the OMB guidelines, GSA shall compile, maintain, and distribute a list of all persons who have been debarred, suspended, or voluntarily excluded by agencies under Executive Order 12549 and these regulations, and those who have been determined to be ineligible.

(b) At a minimum, this list shall indicate:

(1) The names and addresses of all debarred, suspended, ineligible, and voluntarily excluded persons, in alphabetical order, with cross-references

when more than one name is involved in a single action;

(2) The type of action;

(3) The cause for the action;

(4) The scope of the action;

(5) Any termination date for each listing; and

(6) The agency and name and telephone number of the agency point of contact for the action.

**§ 1209.505 NARA responsibilities.**

(a) The agency shall provide GSA with current information concerning debarments, suspension, determinations of ineligibility, and voluntary exclusions it has taken. Until February 18, 1989, the agency shall also provide GSA and OMB with information concerning all transactions in which NARA has granted exceptions under § 1209.215 permitting participation by debarred, suspended, or voluntarily excluded persons.

(b) Unless an alternative schedule is agreed to by GSA, the agency shall advise GSA of the information set forth in § 1209.500(b) and of the exceptions granted under § 1209.215 within five working days after taking such actions.

(c) The agency shall direct inquiries concerning listed persons to the agency that took the action.

(d) Agency officials shall check the Nonprocurement List before entering covered transactions to determine whether a participant in a primary transaction is debarred, suspended, ineligible, or voluntarily excluded (Tel. #).

(e) Agency officials shall check the Nonprocurement List before approving principals or lower tier participants where agency approval of the principal or lower tier participant is required under the terms of the transaction, to determine whether such principals or participants are debarred, suspended, ineligible, or voluntarily excluded.

**§ 1209.510 Participants' responsibilities.**

(a) *Certification by participants in primary covered transactions.* Each participant shall submit the certification in appendix A to this part for it and its principals at the time the participant submits its proposal in connection with

§ 1209.600

a primary covered transaction, except that States need only complete such certification as to their principals. Participants may decide the method and frequency by which they determine the eligibility of their principals. In addition, each participant may, but is not required to, check the Nonprocurement List for its principals (Tel. #). Adverse information on the certification will not necessarily result in denial of participation. However, the certification, and any additional information pertaining to the certification submitted by the participant, shall be considered in the administration of covered transactions.

(b) *Certification by participants in lower tier covered transactions.* (1) Each participant shall require participants in lower tier covered transactions to include the certification in appendix B to this part for it and its principals in any proposal submitted in connection with such lower tier covered transactions.

(2) A participant may rely upon the certification of a prospective participant in a lower tier covered transaction that it and its principals are not debarred, suspended, ineligible, or voluntarily excluded from the covered transaction by any Federal agency, unless it knows that the certification is erroneous. Participants may decide the method and frequency by which they determine the eligibility of their principals. In addition, a participant may, but is not required to, check the Nonprocurement List for its principals and for participants (Tel. ).

(c) *Changed circumstances regarding certification.* A participant shall provide immediate written notice to NARA if at any time the participant learns that its certification was erroneous when submitted or has become erroneous by reason of changed circumstances. Participants in lower tier covered transactions shall provide the same updated notice to the participant to which it submitted its proposals.

**Subpart F—Drug-Free Workplace Requirements (Grants)**

SOURCE: 55 FR 21688, 21700, May 25, 1990, unless otherwise noted.

36 CFR Ch. XII (7–1–03 Edition)

§ 1209.600 Purpose.

(a) The purpose of this subpart is to carry out the Drug-Free Workplace Act of 1988 by requiring that—

(1) A grantee, other than an individual, shall certify to the agency that it will provide a drug-free workplace;

(2) A grantee who is an individual shall certify to the agency that, as a condition of the grant, he or she will not engage in the unlawful manufacture, distribution, dispensing, possession or use of a controlled substance in conducting any activity with the grant.

(b) Requirements implementing the Drug-Free Workplace Act of 1988 for contractors with the agency are found at 48 CFR subparts 9.4, 23.5, and 52.2.

§ 1209.605 Definitions.

(a) Except as amended in this section, the definitions of § 1209.105 apply to this subpart.

(b) For purposes of this subpart—

(1) *Controlled substance* means a controlled substance in schedules I through V of the Controlled Substances Act (21 U.S.C. 812), and as further defined by regulation at 21 CFR 1308.11 through 1308.15;

(2) *Conviction* means a finding of guilt (including a plea of nolo contendere) or imposition of sentence, or both, by any judicial body charged with the responsibility to determine violations of the Federal or State criminal drug statutes;

(3) *Criminal drug statute* means a Federal or non-Federal criminal statute involving the manufacture, distribution, dispensing, use, or possession of any controlled substance;

(4) *Drug-free workplace* means a site for the performance of work done in connection with a specific grant at which employees of the grantee are prohibited from engaging in the unlawful manufacture, distribution, dispensing, possession, or use of a controlled substance;

(5) *Employee* means the employee of a grantee directly engaged in the performance of work under the grant, including:

(i) All *direct charge* employees;



(ii) All *indirect charge* employees, unless their impact or involvement is insignificant to the performance of the grant; and,

(iii) Temporary personnel and consultants who are directly engaged in the performance of work under the grant and who are on the grantee's payroll.

This definition does not include workers not on the payroll of the grantee (e.g., volunteers, even if used to meet a matching requirement; consultants or independent contractors not on the payroll; or employees of subrecipients or subcontractors in covered workplaces);

(6) *Federal agency* or *agency* means any United States executive department, military department, government corporation, government controlled corporation, any other establishment in the executive branch (including the Executive Office of the President), or any independent regulatory agency;

(7) *Grant* means an award of financial assistance, including a cooperative agreement, in the form of money, or property in lieu of money, by a Federal agency directly to a grantee. The term grant includes block grant and entitlement grant programs, whether or not exempted from coverage under the grants management government-wide common rule on uniform administrative requirements for grants and cooperative agreements. The term does not include technical assistance that provides services instead of money, or other assistance in the form of loans, loan guarantees, interest subsidies, insurance, or direct appropriations; or any veterans' benefits to individuals, i.e., any benefit to veterans, their families, or survivors by virtue of the service of a veteran in the Armed Forces of the United States;

(8) *Grantee* means a person who applies for or receives a grant directly from a Federal agency (except another Federal agency);

(9) *Individual* means a natural person;

(10) *State* means any of the States of the United States, the District of Columbia, the Commonwealth of Puerto Rico, any territory or possession of the United States, or any agency of a State, exclusive of institutions of high-

er education, hospitals, and units of local government. A State instrumentality will be considered part of the State government if it has a written determination from a State government that such State considers the instrumentality to be an agency of the State government.

**§ 1209.610 Coverage.**

(a) This subpart applies to any grantee of the agency.

(b) This subpart applies to any grant, except where application of this subpart would be inconsistent with the international obligations of the United States or the laws or regulations of a foreign government. A determination of such inconsistency may be made only by the agency head or his/her designee.

(c) The provisions of subparts A, B, C, D and E of this part apply to matters covered by this subpart, except where specifically modified by this subpart. In the event of any conflict between provisions of this subpart and other provisions of this part, the provisions of this subpart are deemed to control with respect to the implementation of drug-free workplace requirements concerning grants.

**§ 1209.615 Grounds for suspension of payments, suspension or termination of grants, or suspension or debarment.**

A grantee shall be deemed in violation of the requirements of this subpart if the agency head or his or her official designee determines, in writing, that—

(a) The grantee has made a false certification under § 1209.630;

(b) With respect to a grantee other than an individual—

(1) The grantee has violated the certification by failing to carry out the requirements of paragraphs (A)(a)-(g) and/or (B) of the certification (alternate I to appendix C) or

(2) Such a number of employees of the grantee have been convicted of violations of criminal drug statutes for violations occurring in the workplace as to indicate that the grantee has failed to make a good faith effort to provide a drug-free workplace.

**§ 1209.620**

(c) With respect to a grantee who is an individual—

(1) The grantee has violated the certification by failing to carry out its requirements (alternate II to appendix C); or

(2) The grantee is convicted of a criminal drug offense resulting from a violation occurring during the conduct of any grant activity.

**§ 1209.620 Effect of violation.**

(a) In the event of a violation of this subpart as provided in § 1209.615, and in accordance with applicable law, the grantee shall be subject to one or more of the following actions:

(1) Suspension of payments under the grant;

(2) Suspension or termination of the grant; and

(3) Suspension or debarment of the grantee under the provisions of this part.

(b) Upon issuance of any final decision under this part requiring debarment of a grantee, the debarred grantee shall be ineligible for award of any grant from any Federal agency for a period specified in the decision, not to exceed five years (see § 1209.320(a)(2) of this part).

**§ 1209.625 Exception provision.**

The agency head may waive with respect to a particular grant, in writing, a suspension of payments under a grant, suspension or termination of a grant, or suspension or debarment of a grantee if the agency head determines that such a waiver would be in the public interest. This exception authority cannot be delegated to any other official.

**§ 1209.630 Certification requirements and procedures.**

(a)(1) As a prior condition of being awarded a grant, each grantee shall make the appropriate certification to the Federal agency providing the grant, as provided in appendix C to this part.

(2) Grantees are not required to make a certification in order to continue receiving funds under a grant awarded before March 18, 1989, or under a no-cost time extension of such a grant. However, the grantee shall make a one-

time drug-free workplace certification for a non-automatic continuation of such a grant made on or after March 18, 1989.

(b) Except as provided in this section, all grantees shall make the required certification for each grant. For mandatory formula grants and entitlements that have no application process, grantees shall submit a one-time certification in order to continue receiving awards.

(c) A grantee that is a State may elect to make one certification in each Federal fiscal year. States that previously submitted an annual certification are not required to make a certification for Fiscal Year 1990 until June 30, 1990. Except as provided in paragraph (d) of this section, this certification shall cover all grants to all State agencies from any Federal agency. The State shall retain the original of this statewide certification in its Governor's office and, prior to grant award, shall ensure that a copy is submitted individually with respect to each grant, unless the Federal agency has designated a central location for submission.

(d)(1) The Governor of a State may exclude certain State agencies from the statewide certification and authorize these agencies to submit their own certifications to Federal agencies. The statewide certification shall name any State agencies so excluded.

(2) A State agency to which the statewide certification does not apply, or a State agency in a State that does not have a statewide certification, may elect to make one certification in each Federal fiscal year. State agencies that previously submitted a State agency certification are not required to make a certification for Fiscal Year 1990 until June 30, 1990. The State agency shall retain the original of this State agency-wide certification in its central office and, prior to grant award, shall ensure that a copy is submitted individually with respect to each grant, unless the Federal agency designates a central location for submission.

(3) When the work of a grant is done by more than one State agency, the certification of the State agency directly receiving the grant shall be deemed to certify compliance for all

workplaces, including those located in other State agencies.

(e)(1) For a grant of less than 30 days performance duration, grantees shall have this policy statement and program in place as soon as possible, but in any case by a date prior to the date on which performance is expected to be completed.

(2) For a grant of 30 days or more performance duration, grantees shall have this policy statement and program in place within 30 days after award.

(3) Where extraordinary circumstances warrant for a specific grant, the grant officer may determine a different date on which the policy statement and program shall be in place.

**§ 1209.635 Reporting of and employee sanctions for convictions of criminal drug offenses.**

(a) When a grantee other than an individual is notified that an employee has been convicted for a violation of a criminal drug statute occurring in the workplace, it shall take the following actions:

(1) Within 10 calendar days of receiving notice of the conviction, the grantee shall provide written notice, including the convicted employee's position title, to every grant officer, or other designee on whose grant activity the convicted employee was working, unless a Federal agency has designated a central point for the receipt of such notifications. Notification shall include the identification number(s) for each of the Federal agency's affected grants.

(2) Within 30 calendar days of receiving notice of the conviction, the grantee shall do the following with respect to the employee who was convicted.

(i) Take appropriate personnel action against the employee, up to and including termination, consistent with requirements of the Rehabilitation Act of 1973, as amended; or

(ii) Require the employee to participate satisfactorily in a drug abuse assistance or rehabilitation program approved for such purposes by a Federal, State, or local health, law enforcement, or other appropriate agency.

(b) A grantee who is an individual who is convicted for a violation of a criminal drug statute occurring during

the conduct of any grant activity shall report the conviction, in writing, within 10 calendar days, to his or her Federal agency grant officer, or other designee, unless the Federal agency has designated a central point for the receipt of such notices. Notification shall include the identification number(s) for each of the Federal agency's affected grants.

(Approved by the Office of Management and Budget under control number 0991-0002)

**APPENDIX A TO PART 1209—CERTIFICATION REGARDING DEBARMENT, SUSPENSION, AND OTHER RESPONSIBILITY MATTERS—PRIMARY COVERED TRANSACTIONS**

**Instructions for Certification**

1. By signing and submitting this proposal, the prospective primary participant is providing the certification set out below.

2. The inability of a person to provide the certification required below will not necessarily result in denial of participation in this covered transaction. The prospective participant shall submit an explanation of why it cannot provide the certification set out below. The certification or explanation will be considered in connection with the department or agency's determination whether to enter into this transaction. However, failure of the prospective primary participant to furnish a certification or an explanation shall disqualify such person from participation in this transaction.

3. The certification in this clause is a material representation of fact upon which reliance was placed when the department or agency determined to enter into this transaction. If it is later determined that the prospective primary participant knowingly rendered an erroneous certification, in addition to other remedies available to the Federal Government, the department or agency may terminate this transaction for cause or default.

4. The prospective primary participant shall provide immediate written notice to the department or agency to which this proposal is submitted if at any time the prospective primary participant learns that its certification was erroneous when submitted or has become erroneous by reason of changed circumstances.

5. The terms *covered transaction*, *debarred*, *suspended*, *ineligible*, *lower tier covered transaction*, *participant*, *person*, *primary covered transaction*, *principal*, *proposal*, and *voluntarily excluded*, as used in this clause, have the meanings set out in the Definitions and Coverage sections of the rules implementing Executive Order 12549. You may contact the

department or agency to which this proposal is being submitted for assistance in obtaining a copy of those regulations.

6. The prospective primary participant agrees by submitting this proposal that, should the proposed covered transaction be entered into, it shall not knowingly enter into any lower tier covered transaction with a person who is proposed for debarment under 48 CFR part 9, subpart 9.4, debarred, suspended, declared ineligible, or voluntarily excluded from participation in this covered transaction, unless authorized by the department or agency entering into this transaction.

7. The prospective primary participant further agrees by submitting this proposal that it will include the clause titled "Certification Regarding Debarment, Suspension, Ineligibility and Voluntary Exclusion—Lower Tier Covered Transaction," provided by the department or agency entering into this covered transaction, without modification, in all lower tier covered transactions and in all solicitations for lower tier covered transactions.

8. A participant in a covered transaction may rely upon a certification of a prospective participant in a lower tier covered transaction that it is not proposed for debarment under 48 CFR part 9, subpart 9.4, debarred, suspended, ineligible, or voluntarily excluded from the covered transaction, unless it knows that the certification is erroneous. A participant may decide the method and frequency by which it determines the eligibility of its principals. Each participant may, but is not required to, check the List of Parties Excluded from Federal Procurement and Nonprocurement Programs.

9. Nothing contained in the foregoing shall be construed to require establishment of a system of records in order to render in good faith the certification required by this clause. The knowledge and information of a participant is not required to exceed that which is normally possessed by a prudent person in the ordinary course of business dealings.

10. Except for transactions authorized under paragraph 6 of these instructions, if a participant in a covered transaction knowingly enters into a lower tier covered transaction with a person who is proposed for debarment under 48 CFR part 9, subpart 9.4, suspended, debarred, ineligible, or voluntarily excluded from participation in this transaction, in addition to other remedies available to the Federal Government, the department or agency may terminate this transaction for cause or default.

*Certification Regarding Debarment, Suspension, and Other Responsibility Matters—Primary Covered Transactions*

(1) The prospective primary participant certifies to the best of its knowledge and belief, that it and its principals:

(a) Are not presently debarred, suspended, proposed for debarment, declared ineligible, or voluntarily excluded by any Federal department or agency;

(b) Have not within a three-year period preceding this proposal been convicted of or had a civil judgment rendered against them for commission of fraud or a criminal offense in connection with obtaining, attempting to obtain, or performing a public (Federal, State or local) transaction or contract under a public transaction; violation of Federal or State antitrust statutes or commission of embezzlement, theft, forgery, bribery, falsification or destruction of records, making false statements, or receiving stolen property;

(c) Are not presently indicted for or otherwise criminally or civilly charged by a governmental entity (Federal, State or local) with commission of any of the offenses enumerated in paragraph (1)(b) of this certification; and

(d) Have not within a three-year period preceding this application/proposal had one or more public transactions (Federal, State or local) terminated for cause or default.

(2) Where the prospective primary participant is unable to certify to any of the statements in this certification, such prospective participant shall attach an explanation to this proposal.

[60 FR 33042, 33058, June 26, 1995]

APPENDIX B TO PART 1209—CERTIFICATION REGARDING DEBARMENT, SUSPENSION, INELIGIBILITY AND VOLUNTARY EXCLUSION—LOWER TIER COVERED TRANSACTIONS

Instructions for Certification

1. By signing and submitting this proposal, the prospective lower tier participant is providing the certification set out below.

2. The certification in this clause is a material representation of fact upon which reliance was placed when this transaction was entered into. If it is later determined that the prospective lower tier participant knowingly rendered an erroneous certification, in addition to other remedies available to the Federal Government the department or agency with which this transaction originated may pursue available remedies, including suspension and/or debarment.

3. The prospective lower tier participant shall provide immediate written notice to the person to which this proposal is submitted if at any time the prospective lower

tier participant learns that its certification was erroneous when submitted or had become erroneous by reason of changed circumstances.

4. The terms *covered transaction*, *debarred*, *suspended*, *ineligible*, *lower tier covered transaction*, *participant*, *person*, *primary covered transaction*, *principal*, *proposal*, and *voluntarily excluded*, as used in this clause, have the meaning set out in the Definitions and Coverage sections of rules implementing Executive Order 12549. You may contact the person to which this proposal is submitted for assistance in obtaining a copy of those regulations.

5. The prospective lower tier participant agrees by submitting this proposal that, should the proposed covered transaction be entered into, it shall not knowingly enter into any lower tier covered transaction with a person who is proposed for debarment under 48 CFR part 9, subpart 9.4, debarred, suspended, declared ineligible, or voluntarily excluded from participation in this covered transaction, unless authorized by the department or agency with which this transaction originated.

6. The prospective lower tier participant further agrees by submitting this proposal that it will include this clause titled "Certification Regarding Debarment, Suspension, Ineligibility and Voluntary Exclusion—Lower Tier Covered Transaction," without modification, in all lower tier covered transactions and in all solicitations for lower tier covered transactions.

7. A participant in a covered transaction may rely upon a certification of a prospective participant in a lower tier covered transaction that it is not proposed for debarment under 48 CFR part 9, subpart 9.4, debarred, suspended, ineligible, or voluntarily excluded from covered transactions, unless it knows that the certification is erroneous. A participant may decide the method and frequency by which it determines the eligibility of its principals. Each participant may, but is not required to, check the List of Parties Excluded from Federal Procurement and Nonprocurement Programs.

8. Nothing contained in the foregoing shall be construed to require establishment of a system of records in order to render in good faith the certification required by this clause. The knowledge and information of a participant is not required to exceed that which is normally possessed by a prudent person in the ordinary course of business dealings.

9. Except for transactions authorized under paragraph 5 of these instructions, if a participant in a covered transaction knowingly enters into a lower tier covered transaction with a person who is proposed for debarment under 48 CFR part 9, subpart 9.4, suspended, debarred, ineligible, or voluntarily excluded from participation in this transaction, in ad-

dition to other remedies available to the Federal Government, the department or agency with which this transaction originated may pursue available remedies, including suspension and/or debarment.

*Certification Regarding Debarment, Suspension, Ineligibility and Voluntary Exclusion—Lower Tier Covered Transactions*

(1) The prospective lower tier participant certifies, by submission of this proposal, that neither it nor its principals is presently debarred, suspended, proposed for debarment, declared ineligible, or voluntarily excluded from participation in this transaction by any Federal department or agency.

(2) Where the prospective lower tier participant is unable to certify to any of the statements in this certification, such prospective participant shall attach an explanation to this proposal.

[60 FR 33042, 33058, June 26, 1995]

APPENDIX C TO PART 1209—CERTIFICATION REGARDING DRUG-FREE WORKPLACE REQUIREMENTS

*Instructions for Certification*

1. By signing and/or submitting this application or grant agreement, the grantee is providing the certification set out below.

2. The certification set out below is a material representation of fact upon which reliance is placed when the agency awards the grant. If it is later determined that the grantee knowingly rendered a false certification, or otherwise violates the requirements of the Drug-Free Workplace Act, the agency, in addition to any other remedies available to the Federal Government, may take action authorized under the Drug-Free Workplace Act.

3. For grantees other than individuals, Alternate I applies.

4. For grantees who are individuals, Alternate II applies.

5. Workplaces under grants, for grantees other than individuals, need not be identified on the certification. If known, they may be identified in the grant application. If the grantee does not identify the workplaces at the time of application, or upon award, if there is no application, the grantee must keep the identity of the workplace(s) on file in its office and make the information available for Federal inspection. Failure to identify all known workplaces constitutes a violation of the grantee's drug-free workplace requirements.

6. Workplace identifications must include the actual address of buildings (or parts of buildings) or other sites where work under the grant takes place. Categorical descriptions may be used (e.g., all vehicles of a mass transit authority or State highway department while in operation, State employees in

each local unemployment office, performers in concert halls or radio studios).

7. If the workplace identified to the agency changes during the performance of the grant, the grantee shall inform the agency of the change(s), if it previously identified the workplaces in question (see paragraph five).

8. Definitions of terms in the Nonprocurement Suspension and Debarment common rule and Drug-Free Workplace common rule apply to this certification. Grantees' attention is called, in particular, to the following definitions from these rules:

*Controlled substance* means a controlled substance in Schedules I through V of the Controlled Substances Act (21 U.S.C. 812) and as further defined by regulation (21 CFR 1308.11 through 1308.15);

*Conviction* means a finding of guilt (including a plea of nolo contendere) or imposition of sentence, or both, by any judicial body charged with the responsibility to determine violations of the Federal or State criminal drug statutes;

*Criminal drug statute* means a Federal or non-Federal criminal statute involving the manufacture, distribution, dispensing, use, or possession of any controlled substance;

*Employee* means the employee of a grantee directly engaged in the performance of work under a grant, including: (i) All *direct charge* employees; (ii) All *indirect charge* employees unless their impact or involvement is insignificant to the performance of the grant; and, (iii) Temporary personnel and consultants who are directly engaged in the performance of work under the grant and who are on the grantee's payroll. This definition does not include workers not on the payroll of the grantee (e.g., volunteers, even if used to meet a matching requirement; consultants or independent contractors not on the grantee's payroll; or employees of subrecipients or subcontractors in covered workplaces).

*Certification Regarding Drug-Free Workplace Requirements*

ALTERNATE I. (GRANTEES OTHER THAN INDIVIDUALS)

A. The grantee certifies that it will or will continue to provide a drug-free workplace by:

(a) Publishing a statement notifying employees that the unlawful manufacture, distribution, dispensing, possession, or use of a controlled substance is prohibited in the grantee's workplace and specifying the actions that will be taken against employees for violation of such prohibition;

(b) Establishing an ongoing drug-free awareness program to inform employees about—

(1) The dangers of drug abuse in the workplace;

(2) The grantee's policy of maintaining a drug-free workplace;

(3) Any available drug counseling, rehabilitation, and employee assistance programs; and

(4) The penalties that may be imposed upon employees for drug abuse violations occurring in the workplace;

(c) Making it a requirement that each employee to be engaged in the performance of the grant be given a copy of the statement required by paragraph (a);

(d) Notifying the employee in the statement required by paragraph (a) that, as a condition of employment under the grant, the employee will—

(1) Abide by the terms of the statement; and

(2) Notify the employer in writing of his or her conviction for a violation of a criminal drug statute occurring in the workplace no later than five calendar days after such conviction;

(e) Notifying the agency in writing, within ten calendar days after receiving notice under paragraph (d)(2) from an employee or otherwise receiving actual notice of such conviction. Employers of convicted employees must provide notice, including position title, to every grant officer or other designee on whose grant activity the convicted employee was working, unless the Federal agency has designated a central point for the receipt of such notices. Notice shall include the identification number(s) of each affected grant;

(f) Taking one of the following actions, within 30 calendar days of receiving notice under paragraph (d)(2), with respect to any employee who is so convicted—

(1) Taking appropriate personnel action against such an employee, up to and including termination, consistent with the requirements of the Rehabilitation Act of 1973, as amended; or

(2) Requiring such employee to participate satisfactorily in a drug abuse assistance or rehabilitation program approved for such purposes by a Federal, State, or local health, law enforcement, or other appropriate agency;

(g) Making a good faith effort to continue to maintain a drug-free workplace through implementation of paragraphs (a), (b), (c), (d), (e) and (f).

B. The grantee may insert in the space provided below the site(s) for the performance of work done in connection with the specific grant:

Place of Performance (Street address, city, county, state, zip code)

\_\_\_\_\_

Check  if there are workplaces on file that are not identified here.

## National Archives and Records Administration

## § 1210.1

### ALTERNATE II. (GRANTEES WHO ARE INDIVIDUALS)

(a) The grantee certifies that, as a condition of the grant, he or she will not engage in the unlawful manufacture, distribution, dispensing, possession, or use of a controlled substance in conducting any activity with the grant;

(b) If convicted of a criminal drug offense resulting from a violation occurring during the conduct of any grant activity, he or she will report the conviction, in writing, within 10 calendar days of the conviction, to every grant officer or other designee, unless the Federal agency designates a central point for the receipt of such notices. When notice is made to such a central point, it shall include the identification number(s) of each affected grant.

[55 FR 21690, 21700, May 25, 1990]

## PART 1210—UNIFORM ADMINISTRATIVE REQUIREMENTS FOR GRANTS AND AGREEMENTS WITH INSTITUTIONS OF HIGHER EDUCATION, HOSPITALS, AND OTHER NON-PROFIT ORGANIZATIONS

### Subpart A—General

#### Sec.

- 1210.1 Purpose.
- 1210.2 Definitions.
- 1210.3 Effect on other issuances.
- 1210.4 Deviations.
- 1210.5 Subawards.

### Subpart B—Pre-Award Requirements

- 1210.10 Purpose.
- 1210.11 Pre-award policies.
- 1210.12 Forms for applying for Federal assistance.
- 1210.13 Debarment and suspension.
- 1210.14 Special award conditions.
- 1210.15 Metric system of measurement.
- 1210.16 Resource Conservation and Recovery Act.
- 1210.17 Certifications and representations.

### Subpart C—Post-Award Requirements

#### FINANCIAL AND PROGRAM MANAGEMENT

- 1210.20 Purpose of financial and program management.
- 1210.21 Standards for financial management systems.
- 1210.22 Payment.
- 1210.23 Cost sharing or matching.
- 1210.24 Program income.
- 1210.25 Revision of budget and program plans.
- 1210.26 Non-Federal audits.
- 1210.27 Allowable costs.

- 1210.28 Period of availability of funds.

#### PROPERTY STANDARDS

- 1210.30 Purpose of property standards.
- 1210.31 Insurance coverage.
- 1210.32 Real property.
- 1210.33 Federally-owned and exempt property.
- 1210.34 Equipment.
- 1210.35 Supplies and other expendable property.
- 1210.36 Intangible property.
- 1210.37 Property trust relationship.

#### PROCUREMENT STANDARDS

- 1210.40 Purpose of procurement standards.
- 1210.41 Recipient responsibilities.
- 1210.42 Codes of conduct.
- 1210.43 Competition.
- 1210.44 Procurement procedures.
- 1210.45 Cost and price analysis.
- 1210.46 Procurement records.
- 1210.47 Contract administration.
- 1210.48 Contract provisions.

#### REPORTS AND RECORDS

- 1210.50 Purpose of reports and records.
- 1210.51 Monitoring and reporting program performance.
- 1210.52 Financial reporting.
- 1210.53 Retention and access requirements for records.

#### TERMINATION AND ENFORCEMENT

- 1210.60 Purpose of termination and enforcement.
- 1210.61 Termination.
- 1210.62 Enforcement.

### Subpart D—After-the-Award Requirements

- 1210.70 Purpose.
- 1210.71 Closeout procedures.
- 1210.72 Subsequent adjustments and continuing responsibilities.
- 1210.73 Collection of amounts due.

#### APPENDIX A TO PART 1210—CONTRACT PROVISIONS

AUTHORITY: 5 U.S.C. 301; OMB Circular A-110 (64 FR 54926, October 8, 1999).

SOURCE: 60 FR 53515, Oct. 16, 1995, unless otherwise noted.

### Subpart A—General

#### § 1210.1 Purpose.

This part establishes uniform administrative requirements for NHPRC grants and agreements awarded to institutions of higher education, hospitals, and other non-profit organizations. Non-profit organizations that implement NHPRC programs for the

## § 1210.2

## 36 CFR Ch. XII (7-1-03 Edition)

States are also subject to State requirements.

### § 1210.2 Definitions.

(a) *Accrued expenditures* means the charges incurred by the recipient during a given period requiring the provision of funds for:

(1) Goods and other tangible property received;

(2) Services performed by employees, contractors, subrecipients, and other payees; and,

(3) Other amounts becoming owed under programs for which no current services or performance is required.

(b) *Accrued income* means the sum of:

(1) Earnings during a given period from

(i) Services performed by the recipient, and

(ii) Goods and other tangible property delivered to purchasers, and

(2) Amounts becoming owed to the recipient for which no current services or performance is required by the recipient.

(c) *Acquisition cost of equipment* means the net invoice price of the equipment, including the cost of modifications, attachments, accessories, or auxiliary apparatus necessary to make the property usable for the purpose for which it was acquired. Other charges, such as the cost of installation, transportation, taxes, duty or protective in-transit insurance, shall be included or excluded from the unit acquisition cost in accordance with the recipient's regular accounting practices.

(d) *Advance* means a payment made by Treasury check or other appropriate payment mechanism to a recipient upon its request either before outlays are made by the recipient or through the use of predetermined payment schedules.

(e) *Award* means financial assistance that provides support or stimulation to accomplish a public purpose. Awards include grants and other agreements in the form of money or property in lieu of money, by the NHPRC to an eligible recipient. The term does not include: technical assistance, which provides services instead of money; other assistance in the form of loans, loan guarantees, interest subsidies, or insurance; direct payments of any kind to individ-

uals; and, contracts which are required to be entered into and administered under procurement laws and regulations.

(f) *Cash contributions* means the recipient's cash outlay, including the outlay of money contributed to the recipient by third parties.

(g) *Closeout* means the process by which the NHPRC determines that all applicable administrative actions and all required work of the award have been completed by the recipient and the NHPRC.

(h) *Contract* means a procurement contract under an award or subaward, and a procurement subcontract under a recipient's or subrecipient's contract.

(i) *Cost sharing or matching* means that portion of project or program costs not borne by the NHPRC.

(j) *Date of completion* means the date on which all work under an award is completed or the date on the award document, or any supplement or amendment thereto, on which NHPRC sponsorship ends.

(k) *Disallowed costs* means those charges to an award that the NHPRC determines to be unallowable, in accordance with the applicable Federal cost principles or other terms and conditions contained in the award.

(l) *Equipment* means tangible non-expendable personal property including exempt property charged directly to the award having a useful life of more than one year and an acquisition cost of \$5,000 or more per unit. However, consistent with recipient policy, lower limits may be established.

(m) *Excess property* means property under the control of the NHPRC that, as determined by the head thereof, is no longer required for its needs or the discharge of its responsibilities.

(n) *Exempt property* means tangible personal property acquired in whole or in part with NHPRC funds, where the NHPRC has statutory authority to vest title in the recipient without further obligation to the Federal Government. An example of exempt property authority is contained in the Federal Grant and Cooperative Agreement Act (31 U.S.C. 6306), for property acquired under an award to conduct basic or applied research by a non-profit institution of higher education or non-profit



organization whose principal purpose is conducting scientific research.

(o) *Federal awarding agency* means the Federal agency that provides an award to the recipient.

(p) *Federal funds authorized* means the total amount of NHPRC funds obligated by the Federal Government for use by the recipient. This amount may include any authorized carryover of unobligated funds from prior funding periods when permitted by NHPRC regulations or NHPRC implementing instructions.

(q) *Federal share of real property, equipment, or supplies* means that percentage of the property's acquisition costs and any improvement expenditures paid with NHPRC funds.

(r) *Funding period* means the period of time when NHPRC funding is available for obligation by the recipient.

(s) *Intangible property and debt instruments* means, but is not limited to, trademarks, copyrights, patents and patent applications and such property as loans, notes and other debt instruments, lease agreements, stock and other instruments of property ownership, whether considered tangible or intangible.

(t) *NARA* means the National Archives and Records Administration.

(u) *NHPRC* means the National Historical Publications and Records Commission.

(v) *Obligations* means the amounts of orders placed, contracts and grants awarded, services received and similar transactions during a given period that require payment by the recipient during the same or a future period.

(w) *Outlays or expenditures* means charges made to the project or program. They may be reported on a cash or accrual basis. For reports prepared on a cash basis, outlays are the sum of cash disbursements for direct charges for goods and services, the amount of indirect expense charged, the value of third party in-kind contributions applied and the amount of cash advances and payments made to subrecipients. For reports prepared on an accrual basis, outlays are the sum of cash disbursements for direct charges for goods and services, the amount of indirect expense incurred, the value of in-kind contributions applied, and the net in-

crease (or decrease) in the amounts owed by the recipient for goods and other property received, for services performed by employees, contractors, subrecipients and other payees and other amounts becoming owed under programs for which no current services or performance are required.

(x) *Personal property* means property of any kind except real property. It may be tangible, having physical existence, or intangible, having no physical existence, such as copyrights, patents, or securities.

(y) *Prior approval* means written approval by an authorized official evidencing prior consent.

(z) *Program income* means gross income earned by the recipient that is directly generated by a supported activity or earned as a result of the award (see exclusions in §1210.24 (e) and (h)). Program income includes, but is not limited to, income from fees for services performed, the use or rental of real or personal property acquired under federally-funded projects, the sale of commodities or items fabricated under an award, license fees and royalties on patents and copyrights, and interest on loans made with award funds. Interest earned on advances of Federal funds is not program income. Except as otherwise provided in NHPRC regulations or the terms and conditions of the award, program income does not include the receipt of principal on loans, rebates, credits, discounts, etc., or interest earned on any of them.

(aa) *Project costs* means all allowable costs, as set forth in the applicable Federal cost principles, incurred by a recipient and the value of the contributions made by third parties in accomplishing the objectives of the award during the project period.

(bb) *Project period* means the period established in the award document during which NHPRC sponsorship begins and ends.

(cc) *Property* means, unless otherwise stated, real property, equipment, intangible property and debt instruments.

(dd) *Real property* means land, including land improvements, structures and appurtenances thereto, but excludes movable machinery and equipment.

(ee) *Recipient* means an organization receiving financial assistance directly from the NHPRC to carry out a project or program. The term includes public and private institutions of higher education, public and private hospitals, and other quasi-public and private nonprofit organizations such as, but not limited to, community action agencies, research institutes, educational associations, and health centers. The term may include commercial organizations, foreign or international organizations (such as agencies of the United Nations) which are recipients, subrecipients, or contractors or subcontractors of recipients or subrecipients at the discretion of the NHPRC. The term does not include government-owned contractor-operated facilities or research centers providing continued support for mission-oriented, large-scale programs that are government-owned or controlled, or are designated as federally-funded research and development centers.

(ff) *Research and development* means all research activities, both basic and applied, and all development activities that are supported at universities, colleges, and other non-profit institutions. "Research" is defined as a systematic study directed toward fuller scientific knowledge or understanding of the subject studied. "Development" is the systematic use of knowledge and understanding gained from research directed toward the production of useful materials, devices, systems, or methods, including design and development of prototypes and processes. The term research also includes activities involving the training of individuals in research techniques where such activities utilize the same facilities as other research and development activities and where such activities are not included in the instruction function.

(gg) *Small awards* means a grant or cooperative agreement not exceeding the small purchase threshold fixed at 41 U.S.C. 403(11) (currently \$25,000).

(hh) *Subaward* means an award of financial assistance in the form of money, or property in lieu of money, made under an award by a recipient to an eligible subrecipient or by a subrecipient to a lower tier subrecipient. The term includes financial assistance

when provided by any legal agreement, even if the agreement is called a contract, but does not include procurement of goods and services nor does it include any form of assistance which is excluded from the definition of "award" in paragraph (e) of this section.

(ii) *Subrecipient* means the legal entity to which a subaward is made and which is accountable to the recipient for the use of the funds provided. The term may include foreign or international organizations (such as agencies of the United Nations) at the discretion of the NHPRC.

(jj) *Supplies* means all personal property excluding equipment, intangible property, and debt instruments as defined in this section, and inventions of a contractor conceived or first actually reduced to practice in the performance of work under a funding agreement ("subject inventions"), as defined in 37 CFR Part 401, "Rights to Inventions Made by Nonprofit Organizations and Small Business Firms Under Government Grants, Contracts, and Cooperative Agreements."

(kk) *Suspension* means an action by the NHPRC that temporarily withdraws Federal sponsorship under an award, pending corrective action by the recipient or pending a decision to terminate the award by the NHPRC. Suspension of an award is a separate action from suspension under NARA regulations implementing E.O. 12549 and E.O. 12689, "Debarment and Suspension" (36 CFR Part 1209).

(ll) *Termination* means the cancellation of NHPRC sponsorship, in whole or in part, under an agreement at any time prior to the date of completion.

(mm) *Third party in-kind contributions* means the value of non-cash contributions provided by non-Federal third parties. Third party in-kind contributions may be in the form of real property, equipment, supplies and other expendable property, and the value of goods and services directly benefiting and specifically identifiable to the project or program.

(nn) *Unliquidated obligations*, for financial reports prepared on a cash basis, means the amount of obligations incurred by the recipient that have not been paid. For reports prepared on an

## National Archives and Records Administration

## § 1210.12

accrued expenditure basis, they represent the amount of obligations incurred by the recipient for which an outlay has not been recorded.

(oo) *Unobligated balance* means the portion of the funds authorized by the NHPRC that has not been obligated by the recipient and is determined by deducting the cumulative obligations from the cumulative funds authorized.

(pp) *Unrecovered indirect cost* means the difference between the amount awarded and the amount which could have been awarded under the recipient's approved negotiated indirect cost rate.

(qq) *Working capital advance* means a procedure whereby funds are advanced to the recipient to cover its estimated disbursement needs for a given initial period.

### § 1210.3 Effect on other issuances.

For awards subject to this part, all administrative requirements of codified program regulations, program manuals, handbooks and other non-regulatory materials which are inconsistent with the requirements of this part shall be superseded, except to the extent they are required by statute, or authorized in accordance with the deviations provision in § 1210.4.

### § 1210.4 Deviations.

The Office of Management and Budget (OMB) may grant exceptions for classes of grants or recipients subject to the requirements of this part when exceptions are not prohibited by statute. However, in the interest of maximum uniformity, exceptions from the requirements of this part shall be permitted only in unusual circumstances. The NHPRC may apply more restrictive requirements to a class of recipients when approved by OMB. The NHPRC may apply less restrictive requirements when awarding small awards, except for those requirements which are statutory. Exceptions on a case-by-case basis may also be made by the NHPRC.

### § 1210.5 Subawards.

Unless sections of this part specifically exclude subrecipients from coverage, the provisions of this part shall be applied to subrecipients performing

work under awards if such subrecipients are institutions of higher education, hospitals or other non-profit organizations. State and local government subrecipients are subject to the provisions of regulations implementing the grants management common rule, "Uniform Administrative Requirements for Grants and Cooperative Agreements to State and Local Governments," published at 36 CFR part 1207.

## Subpart B—Pre-Award Requirements

### § 1210.10 Purpose.

Sections 1210.11 through 1210.17 prescribes forms and instructions and other pre-award matters to be used in applying for NHPRC awards.

### § 1210.11 Pre-award policies.

(a) *Use of grants and cooperative agreements, and contracts.* In each instance, the NHPRC shall decide on the appropriate award instrument (i.e., grant, cooperative agreement, or contract). The Federal Grant and Cooperative Agreement Act (31 U.S.C. 6301-08) governs the use of grants, cooperative agreements and contracts. A grant or cooperative agreement shall be used only when the principal purpose of a transaction is to accomplish a public purpose of support or stimulation authorized by Federal statute. The statutory criterion for choosing between grants and cooperative agreements is that for the latter, "substantial involvement is expected between the executive agency and the State, local government, or other recipient when carrying out the activity contemplated in the agreement." Contracts shall be used when the principal purpose is acquisition of property or services for the direct benefit or use of the Federal Government.

(b) *Public notice and priority setting.* The NHPRC shall notify the public of its intended funding priorities for discretionary grant programs.

### § 1210.12 Forms for applying for Federal assistance.

(a) The NHPRC shall comply with the applicable report clearance requirements of 5 CFR Part 1320, "Controlling

### § 1210.13

Paperwork Burdens on the Public,” with regard to all forms used by the NHPRC in place of or as a supplement to the Standard Form 424 (SF-424) series.

(b) Applicants shall use the SF-424 (Application for Federal Assistance) and NA Form 17001 (Budget Form) forms and instructions prescribed by the NHPRC Program Guidelines. OMB Control Number 3095-0004 has been assigned to the Budget Form. OMB Control Number 3095-0013 has been assigned to the NHPRC Program Guidelines.

(c) Applicants shall complete the appropriate sections of the SF-424 (Application for Federal Assistance) indicating whether the application was subject to review by the State Single Point of Contact (SPOC) under E.O. 12372, “Intergovernmental Review of Federal Programs.” The name and address of the SPOC for a particular State can be obtained from the NHPRC or the Catalog of Federal Domestic Assistance. The SPOC shall advise the applicant whether the program for which application is made has been selected by that State for review.

### § 1210.13 Debarment and suspension.

The NHPRC and recipients shall comply with the nonprocurement debarment and suspension common rule implementing E.O.s 12549 and 12689, “Debarment and Suspension” (36 CFR Part 1209). This common rule restricts subawards and contracts with certain parties that are debarred, suspended or otherwise excluded from or ineligible for participation in Federal assistance programs or activities.

### § 1210.14 Special award conditions.

If an applicant or recipient has a history of poor performance, is not financially stable, has a management system that does not meet the standards prescribed in this part, has not conformed to the terms and conditions of a previous award, or is not otherwise responsible, the NHPRC may impose additional requirements as needed, provided that such applicant or recipient is notified in writing as to: the nature of the additional requirements, the reason why the additional requirements are being imposed, the nature of the

### 36 CFR Ch. XII (7-1-03 Edition)

corrective action needed, the time allowed for completing the corrective actions, and the method for requesting reconsideration of the additional requirements imposed. Any special conditions shall be promptly removed once the conditions that prompted them have been corrected.

### § 1210.15 Metric system of measurement.

The Metric Conversion Act, as amended by the Omnibus Trade and Competitiveness Act (15 U.S.C. 205) declares that the metric system is the preferred measurement system for U.S. trade and commerce. The Act requires NARA to establish a date or dates in consultation with the Secretary of Commerce, when the metric system of measurement will be used in NARA’s procurements, grants, and other business-related activities. Metric implementation may take longer where the use of the system is initially impractical or likely to cause significant inefficiencies in the accomplishment of federally-funded activities. NARA shall follow the provisions of E.O. 12770, “Metric Usage in Federal Government Programs.”

### § 1210.16 Resource Conservation and Recovery Act.

Under the Resource Conservation and Recovery Act ((RCRA) (Pub. L. 94-580 codified at 42 U.S.C. 6962), any State agency or agency of a political subdivision of a State which is using appropriated Federal funds must comply with section 6002. Section 6002 requires that preference be given in procurement programs to the purchase of specific products containing recycled materials identified in guidelines developed by the Environmental Protection Agency (EPA) (40 CFR Parts 247 through 254). Accordingly, State and local institutions of higher education, hospitals, and non-profit organizations that receive direct Federal awards or other Federal funds shall give preference in their procurement programs funded with Federal funds to the purchase of recycled products pursuant to the EPA guidelines.

**§ 1210.17 Certifications and representations.**

Unless prohibited by statute or codified regulation, the NHPRC is authorized to allow recipients to submit certifications and representations required by statute, executive order, or regulation on an annual basis, if they have an ongoing and continuing relationship with the NHPRC. Annual certifications and representations shall be signed by responsible officials with the authority to ensure recipients' compliance with the pertinent requirements.

**Subpart C—Post-Award Requirements**

## FINANCIAL AND PROGRAM MANAGEMENT

**§ 1210.20 Purpose of financial and program management.**

Sections 1210.21 through 1210.28 prescribe standards for financial management systems, methods for making payments and rules for: satisfying cost sharing and matching requirements, accounting for program income, budget revision approvals, making audits, determining allowability of cost, and establishing fund availability.

**§ 1210.21 Standards for financial management systems.**

(a) The NHPRC shall require recipients to relate financial data to performance data and develop unit cost information whenever practical.

(b) Recipients' financial management systems shall provide for the following.

(1) Accurate, current and complete disclosure of the financial results of each NHPRC-sponsored project or program in accordance with the reporting requirements set forth in § 1210.52.

(2) Records that identify adequately the source and application of funds for NHPRC-sponsored activities. These records shall contain information pertaining to NHPRC awards, authorizations, obligations, unobligated balances, assets, outlays, income and interest.

(3) Effective control over and accountability for all funds, property and other assets. Recipients shall adequately safeguard all such assets and assure they are used solely for authorized purposes.

(4) Comparison of outlays with budget amounts for each award. Whenever appropriate, financial information should be related to performance and unit cost data.

(5) Written procedures to minimize the time elapsing between the transfer of funds to the recipient from the U.S. Treasury and the issuance or redemption of checks, warrants or payments by other means for program purposes by the recipient. To the extent that the provisions of the Cash Management Improvement Act (CMIA) (Pub. L. 101-453) govern, payment methods of State agencies, instrumentalities, and fiscal agents shall be consistent with CMIA Treasury-State Agreements or the CMIA default procedures codified at 31 CFR Part 205, "Withdrawal of Cash from the Treasury for Advances under Federal Grant and Other Programs."

(6) Written procedures for determining the reasonableness, allocability and allowability of costs in accordance with the provisions of the applicable Federal cost principles and the terms and conditions of the award.

(7) Accounting records including cost accounting records that are supported by source documentation.

(c) Where the Federal Government guarantees or insures the repayment of money borrowed by the recipient, the NHPRC, at its discretion, may require adequate bonding and insurance if the bonding and insurance requirements of the recipient are not deemed adequate to protect the interest of the Federal Government.

(d) The NHPRC may require adequate fidelity bond coverage where the recipient lacks sufficient coverage to protect the Federal Government's interest.

(e) Where bonds are required in the situations described in this section, the bonds shall be obtained from companies holding certificates of authority as acceptable sureties, as prescribed in 31 CFR Part 223, "Surety Companies Doing Business with the United States."

**§ 1210.22 Payment.**

(a) Payment methods shall minimize the time elapsing between the transfer of funds from the United States Treasury and the issuance or redemption of

**§ 1210.22**

**36 CFR Ch. XII (7-1-03 Edition)**

checks, warrants, or payment by other means by the recipients. Payment methods of State agencies or instrumentalities shall be consistent with Treasury-State CMIA agreements or default procedures codified at 31 CFR Part 205.

(b) Recipients will be paid in advance, provided they maintain or demonstrate the willingness to maintain written procedures that minimize the time elapsing between the transfer of funds and disbursement by the recipient, and financial management systems that meet the standards for fund control and accountability as established in §1210.21. Cash advances to a recipient organization shall be limited to the minimum amounts needed and be timed to be in accordance with the actual, immediate cash requirements of the recipient organization in carrying out the purpose of the approved program or project. The timing and amount of cash advances shall be as close as is administratively feasible to the actual disbursements by the recipient organization for direct program or project costs and the proportionate share of any allowable indirect costs.

(c) Whenever possible, advances shall be consolidated to cover anticipated cash needs for all awards made by the NHPRC to the recipient.

(1) Advance payment mechanisms include, but are not limited to, Treasury check and electronic funds transfer.

(2) Advance payment mechanisms are subject to 31 CFR Part 205.

(3) Recipients can submit requests for advances and reimbursements at least monthly when a predetermined schedule of electronic funds transfer is not used.

(d) Requests for Treasury check advance payment shall be submitted on SF-270, "Request for Advance or Reimbursement," or other forms as may be authorized by OMB. This form is not to be used when Treasury check advance payments are made to the recipient automatically through the use of a predetermined payment schedule or if precluded by special NHPRC instructions for electronic funds transfer.

(e) Reimbursement is the preferred method when the requirements in paragraph (b) of this section cannot be met.

(1) When the reimbursement method is used, the NHPRC shall make payment within 30 days after receipt of the billing, unless the billing is improper.

(2) Recipients can submit a request for reimbursement at least monthly when a predetermined schedule of electronic funds transfer is not used.

(f) If a recipient cannot meet the criteria for advance payments and the NHPRC has determined that reimbursement is not feasible because the recipient lacks sufficient working capital, the NHPRC may provide cash on a working capital advance basis. Under this procedure, the NHPRC shall advance cash to the recipient to cover its estimated disbursement needs for an initial period generally geared to the awardee's disbursing cycle. Thereafter, the NHPRC shall reimburse the recipient for its actual cash disbursements. The working capital advance method of payment shall not be used for recipients unwilling or unable to provide timely advances to their subrecipient to meet the subrecipient's actual cash disbursements.

(g) To the extent available, recipients shall disburse funds available from repayments to and interest earned on a revolving fund, program income, rebates, refunds, contract settlements, audit recoveries and interest earned on such funds before requesting additional cash payments.

(h) Unless otherwise required by statute, the NHPRC shall not withhold payments for proper charges made by recipients at any time during the project period unless paragraph (h)(1) or (2) of this section apply.

(1) A recipient has failed to comply with the project objectives, the terms and conditions of the award, or NHPRC reporting requirements.

(2) The recipient or subrecipient is delinquent in a debt to the United States as defined in OMB Circular A-129, "Managing Federal Credit Programs." Under such conditions, the NHPRC may, upon reasonable notice, inform the recipient that payments shall not be made for obligations incurred after a specified date until the conditions are corrected or the indebtedness to the Federal Government is liquidated.

(i) Standards governing the use of banks and other institutions as depositories of funds advanced under awards are as follows.

(1) Except for situations described in paragraph (i)(2) of this section, the NHPRC shall not require separate depository accounts for funds provided to a recipient or establish any eligibility requirements for depositories for funds provided to a recipient. However, recipients must be able to account for the receipt, obligation and expenditure of funds.

(2) Advances of NHPRC funds shall be deposited and maintained in insured accounts whenever possible.

(j) Consistent with the national goal of expanding the opportunities for women-owned and minority-owned business enterprises, recipients shall be encouraged to use women-owned and minority-owned banks (a bank which is owned at least 50 percent by women or minority group members).

(k) Recipients shall maintain advances of NHPRC funds in interest bearing accounts, unless paragraphs (k)(1), (2) or (3) of this section apply.

(1) The recipient receives less than \$120,000 in Federal awards per year.

(2) The best reasonably available interest bearing account would not be expected to earn interest in excess of \$250 per year on Federal cash balances.

(3) The depository would require an average or minimum balance so high that it would not be feasible within the expected Federal and non-Federal cash resources.

(l) In keeping with Electronic Funds Transfer rules (31 CFR Part 206), interest earned should be remitted annually to the Department of Health and Human Services (HHS) Payment Management System through an electronic medium such as the FEDWIRE Deposit system. Recipients which do not have this capability should use a check and mail it to the Payment Management System, P.O. Box 6021, Rockville, MD 20852. Interest amounts up to \$250 per year may be retained by the recipient for administrative expense. State universities and hospitals shall comply with CMIA, as it pertains to interest. If an entity subject to CMIA uses its own funds to pay pre-award costs for discretionary awards without prior written

approval from the NHPRC, it waives its right to recover the interest under CMIA.

(m) Except as noted elsewhere in this part, only the SF-270, Request for Advance or Reimbursement, shall be authorized for the recipients in requesting advances and reimbursements. The NHPRC requires an original and two copies of this form.

#### § 1210.23 Cost sharing or matching.

(a) All contributions, including cash and third party in-kind, shall be accepted as part of the recipient's cost sharing or matching when such contributions meet all of the following criteria.

(1) Are verifiable from the recipient's records.

(2) Are not included as contributions for any other federally-assisted project or program.

(3) Are necessary and reasonable for proper and efficient accomplishment of project or program objectives.

(4) Are allowable under the applicable cost principles.

(5) Are not paid by the Federal Government under another award, except where authorized by Federal statute to be used for cost sharing or matching.

(6) Are provided for in the approved budget when required by the NHPRC.

(7) Conform to other provisions of this part, as applicable.

(b) Unrecovered indirect costs may be included as part of cost sharing or matching only with the prior approval of the NHPRC.

(c) Values for recipient contributions of services and property shall be established in accordance with the applicable cost principles. If the NHPRC authorizes recipients to donate buildings or land for construction/facilities acquisition projects or long-term use, the value of the donated property for cost sharing or matching shall be the lesser of paragraph (c)(1) or (2) of this section.

(1) The certified value of the remaining life of the property recorded in the recipient's accounting records at the time of donation.

(2) The current fair market value. However, when there is sufficient justification, the NHPRC may approve the use of the current fair market value of the donated property, even if it exceeds

§ 1210.24

36 CFR Ch. XII (7-1-03 Edition)

the certified value at the time of donation to the project.

(d) Volunteer services furnished by professional and technical personnel, consultants, and other skilled and unskilled labor may be counted as cost sharing or matching if the service is an integral and necessary part of an approved project or program. Rates for volunteer services shall be consistent with those paid for similar work in the recipient's organization. In those instances in which the required skills are not found in the recipient organization, rates shall be consistent with those paid for similar work in the labor market in which the recipient competes for the kind of services involved. In either case, paid fringe benefits that are reasonable, allowable, and allocable may be included in the valuation.

(e) When an employer other than the recipient furnishes the services of an employee, these services shall be valued at the employee's regular rate of pay (plus an amount of fringe benefits that are reasonable, allowable, and allocable, but exclusive of overhead costs), provided these services are in the same skill for which the employee is normally paid.

(f) Donated supplies may include such items as expendable equipment, office supplies, laboratory supplies or workshop and classroom supplies. Value assessed to donated supplies included in the cost sharing or matching share shall be reasonable and shall not exceed the fair market value of the property at the time of the donation.

(g) The method used for determining cost sharing or matching for donated equipment, buildings and land for which title passes to the recipient may differ according to the purpose of the award, if paragraph (g)(1) or (2) of this section apply.

(1) If the purpose of the award is to assist the recipient in the acquisition of equipment, buildings or land, the total value of the donated property may be claimed as cost sharing or matching.

(2) If the purpose of the award is to support activities that require the use of equipment, buildings or land, normally only depreciation or use charges for equipment and buildings may be made. However, the full value of equip-

ment or other capital assets and fair rental charges for land may be allowed, provided that the NHPRC has approved the charges.

(h) The value of donated property shall be determined in accordance with the usual accounting policies of the recipient, with the following qualifications.

(1) The value of donated land and buildings shall not exceed its fair market value at the time of donation to the recipient as established by an independent appraiser (e.g., certified real property appraiser or General Services Administration representative) and certified by a responsible official of the recipient.

(2) The value of donated equipment shall not exceed the fair market value of equipment of the same age and condition at the time of donation.

(3) The value of donated space shall not exceed the fair rental value of comparable space as established by an independent appraisal of comparable space and facilities in a privately-owned building in the same locality.

(4) The value of loaned equipment shall not exceed its fair rental value.

(5) The following requirements pertain to the recipient's supporting records for in-kind contributions from third parties.

(i) Volunteer services shall be documented and, to the extent feasible, supported by the same methods used by the recipient for its own employees.

(ii) The basis for determining the valuation for personal service, material, equipment, buildings and land shall be documented.

§ 1210.24 Program income.

(a) The NHPRC applies the standards set forth in this section in requiring recipient organizations to account for program income related to projects financed in whole or in part with Federal funds.

(b) Except as provided in paragraph (h) of this section, program income earned during the project period shall be retained by the recipient and, in accordance with these regulations or the terms and conditions of the award, shall be used in one or more of the ways listed in the following.



(1) Added to funds committed to the project by the NHPRC and recipient and used to further eligible project or program objectives.

(2) Used to finance the non-Federal share of the project or program.

(3) Deducted from the total project or program allowable cost in determining the net allowable costs on which the Federal share of costs is based.

(c) When the NHPRC authorizes the disposition of program income as described in paragraphs (b)(1) or (b)(2) of this section, program income in excess of any limits stipulated shall be used in accordance with paragraph (b)(3) of this section.

(d) In the event that the NHPRC does not specify in its regulations or the terms and conditions of the award how program income is to be used, paragraph (b)(3) of this section shall apply automatically to all projects or programs except research. For awards that support research, paragraph (b)(1) of this section shall apply automatically unless the NHPRC indicates in the terms and conditions another alternative on the award or the recipient is subject to special award conditions, as indicated in § 1210.14.

(e) Unless NHPRC regulations or the terms and conditions of the award provide otherwise, recipients shall have no obligation to the Federal Government regarding program income earned after the end of the project period.

(f) If authorized by NHPRC regulations or the terms and conditions of the award, costs incident to the generation of program income may be deducted from gross income to determine program income, provided these costs have not been charged to the award.

(g) Proceeds from the sale of property shall be handled in accordance with the requirements of the Property Standards (See §§ 1210.30 through 1210.37).

(h) Unless NHPRC regulations or the terms and condition of the award provide otherwise, recipients shall have no obligation to the Federal Government with respect to program income earned from license fees and royalties for copyrighted material, patents, patent applications, trademarks, and inventions produced under an award. However, Patent and Trademark Amendments (35 U.S.C. 18) apply to inventions

made under an experimental, developmental, or research award.

**§ 1210.25 Revision of budget and program plans.**

(a) The budget plan is the financial expression of the project or program as approved during the award process. It may include either the Federal and non-Federal share, or only the Federal share, depending upon NHPRC requirements. It shall be related to performance for program evaluation purposes whenever appropriate.

(b) Recipients are required to report deviations from budget and program plans, and request prior approvals for budget and program plan revisions, in accordance with this section.

(c) Recipients shall request prior approvals from the NHPRC for one or more of the following program or budget related reasons.

(1) Change in the scope or the objective of the project or program (even if there is no associated budget revision requiring prior written approval).

(2) Change in a key person specified in the application or award document.

(3) The absence for more than three months, or a 25 percent reduction in time devoted to the project, by the approved project director or principal investigator.

(4) The need for additional NHPRC funding.

(5) The transfer of amounts budgeted for indirect costs to absorb increases in direct costs, or vice versa, if approval is required by the NHPRC.

(6) The inclusion, unless waived by the NHPRC, of costs that require prior approval in accordance with OMB Circular A-21, "Cost Principles for Institutions of Higher Education," OMB Circular A-122, "Cost Principles for Non-Profit Organizations," or 45 CFR Part 74 Appendix E, "Principles for Determining Costs Applicable to Research and Development under Grants and Contracts with Hospitals," or 48 CFR Part 31, "Contract Cost Principles and Procedures," as applicable.

(7) The transfer of funds allotted for training allowances (direct payment to trainees) to other categories of expense.

(8) Unless described in the application and funded in the approved

**§ 1210.26**

**36 CFR Ch. XII (7-1-03 Edition)**

awards, the subaward, transfer or contracting out of any work under an award. This provision does not apply to the purchase of supplies, material, equipment or general support services.

(d) No other prior approval requirements for specific items will be imposed unless a deviation has been approved by OMB.

(e) Except for requirements listed in paragraphs (c)(1) and (c)(4) of this section, the NHPRC is authorized, at their option, to waive cost-related and administrative prior written approvals required by this Circular and OMB Circulars A-21 and A-122. Such waivers may include authorizing recipients to do any one or more of the following.

(1) Incur pre-award costs 90 calendar days prior to award or more than 90 calendar days with the prior approval of the NHPRC. All pre-award costs are incurred at the recipient's risk (i.e., the NHPRC is under no obligation to reimburse such costs if for any reason the recipient does not receive an award or if the award is less than anticipated and inadequate to cover such costs).

(2) Initiate a one-time extension of the expiration date of the award of up to 12 months unless one or more of the following conditions apply. For one-time extensions, the recipient must notify the NHPRC in writing with the supporting reasons and revised expiration date at least 10 days before the expiration date specified in the award. This one-time extension may not be exercised merely for the purpose of using unobligated balances.

(i) The terms and conditions of award prohibit the extension.

(ii) The extension requires additional NHPRC funds.

(iii) The extension involves any change in the approved objectives or scope of the project.

(3) Carry forward unobligated balances to subsequent funding periods.

(4) For awards that support research, unless the NHPRC provides otherwise in the award or in NHPRC's regulations, the prior approval requirements described in paragraph (e) of this section are automatically waived (i.e., recipients need not obtain such prior approvals) unless one of the conditions included in paragraph (e)(2) of this section applies.

(f) The NHPRC may, at its option, restrict the transfer of funds among direct cost categories or programs, functions and activities for awards in which the Federal share of the project exceeds \$100,000 and the cumulative amount of such transfers exceeds or is expected to exceed 10 percent of the total budget as last approved by the NHPRC. The NHPRC shall not permit a transfer that would cause any Federal appropriation or part thereof to be used for purposes other than those consistent with the original intent of the appropriation.

(g) All other changes to nonconstruction budgets, except for the changes described in paragraph (j), do not require prior approval.

(h) [Reserved]

(i) No other prior approval requirements for specific items will be imposed unless a deviation has been approved by OMB.

(j) The NHPRC shall require recipients to notify the NHPRC in writing promptly whenever the amount of Federal authorized funds is expected to exceed the needs of the recipient for the project period by more than \$5,000 or five percent of the NHPRC award, whichever is greater. This notification shall not be required if an application for additional funding is submitted for a continuation award.

(k) When requesting approval for budget revisions, recipients shall use the budget forms that were used in the application unless the NHPRC indicates a letter of request suffices.

(l) Within 30 calendar days from the date of receipt of the request for budget revisions, the NHPRC shall review the request and notify the recipient whether the budget revisions have been approved. If the revision is still under consideration at the end of 30 calendar days, the NHPRC shall inform the recipient in writing of the date when the recipient may expect the decision.

**§ 1210.26 Non-Federal audits.**

(a) Recipients and subrecipients that are institutions of higher education or other non-profit organizations (including hospitals) shall be subject to the audit requirements contained in the Single Audit Act Amendments of 1996 (31 U.S.C. 7501-7507) and revised OMB

## National Archives and Records Administration

## § 1210.32

Circular A-133, "Audits of States, Local Governments, and Non-Profit Organizations."

(b) State and local governments shall be subject to the audit requirements contained in the Single Audit Act Amendments of 1996 (31 U.S.C. 7501-7507) and revised OMB Circular A-133, "Audits of States, Local Governments, and Non-Profit Organizations."

(c) For-profit hospitals not covered by the audit provisions of revised OMB Circular A-133 shall be subject to the audit requirements of the Federal awarding agencies.

[62 FR 45939, 45943, Aug. 29, 1997]

### § 1210.27 Allowable costs.

For each kind of recipient, there is a set of Federal principles for determining allowable costs. Allowability of costs shall be determined in accordance with the cost principles applicable to the entity incurring the costs. Thus, allowability of costs incurred by State, local or federally-recognized Indian tribal governments is determined in accordance with the provisions of OMB Circular A-87, "Cost Principles for State and Local Governments." The allowability of costs incurred by non-profit organizations is determined in accordance with the provisions of OMB Circular A-122, "Cost Principles for Non-Profit Organizations." The allowability of costs incurred by institutions of higher education is determined in accordance with the provisions of OMB Circular A-21, "Cost Principles for Educational Institutions." The allowability of costs incurred by hospitals is determined in accordance with the provisions of Appendix E of 45 CFR Part 74, "Principles for Determining Costs Applicable to Research and Development Under Grants and Contracts with Hospitals." The allowability of costs incurred those non-profit organizations listed in Attachment C to Circular A-122 is determined in accordance with the provisions of the Federal Acquisition Regulation (FAR) at 48 CFR Part 31.

### § 1210.28 Period of availability of funds.

Where a funding period is specified, a recipient may charge to the grant only allowable costs resulting from obliga-

tions incurred during the funding period and any pre-award costs authorized by the NHPRC.

### PROPERTY STANDARDS

### § 1210.30 Purpose of property standards.

Sections 1210.31 through 1210.37 set forth uniform standards governing management and disposition of property furnished by the Federal Government whose cost was charged to a project supported by an NHPRC award. The NHPRC requires recipients to observe these standards under awards and shall not impose additional requirements, unless specifically required by Federal statute. The recipient may use its own property management standards and procedures provided it observes the provisions of §§ 1210.31 through 1210.37.

### § 1210.31 Insurance coverage.

Recipients shall, at a minimum, provide the equivalent insurance coverage for real property and equipment acquired with NHPRC funds as provided to property owned by the recipient. Federally-owned property need not be insured unless required by the terms and conditions of the award.

### § 1210.32 Real property.

The NHPRC shall prescribe requirements for recipients concerning the use and disposition of real property acquired in whole or in part under awards. Unless otherwise provided by statute, such requirements, at a minimum, shall contain the following.

(a) Title to real property shall vest in the recipient subject to the condition that the recipient shall use the real property for the authorized purpose of the project as long as it is needed and shall not encumber the property without approval of the NHPRC.

(b) The recipient shall obtain written approval by the NHPRC for the use of real property in other federally-sponsored projects when the recipient determines that the property is no longer needed for the purpose of the original project. Use in other projects shall be limited to those under federally-sponsored projects (i.e., awards) or programs that have purposes consistent

### § 1210.33

with those authorized for support by the NHPRC.

(c) When the real property is no longer needed as provided in paragraphs (a) and (b) of this section, the recipient shall request disposition instructions from the NHPRC or its successor Federal awarding agency. The NHPRC shall observe one or more of the following disposition instructions.

(1) The recipient may be permitted to retain title without further obligation to the Federal Government after it compensates the Federal Government for that percentage of the current fair market value of the property attributable to the Federal participation in the project.

(2) The recipient may be directed to sell the property under guidelines provided by the NHPRC and pay the Federal Government for that percentage of the current fair market value of the property attributable to the Federal participation in the project (after deducting actual and reasonable selling and fix-up expenses, if any, from the sales proceeds). When the recipient is authorized or required to sell the property, proper sales procedures shall be established that provide for competition to the extent practicable and result in the highest possible return.

(3) The recipient may be directed to transfer title to the property to the Federal Government or to an eligible third party provided that, in such cases, the recipient shall be entitled to compensation for its attributable percentage of the current fair market value of the property.

### § 1210.33 Federally-owned and exempt property.

(a) Federally-owned property.

(1) Title to federally-owned property remains vested in the Federal Government. Recipients shall submit annually an inventory listing of federally-owned property in their custody to the NHPRC. Upon completion of the award or when the property is no longer needed, the recipient shall report the property to the NHPRC for further Federal agency utilization.

(2) If the NHPRC has no further need for the property, it shall be declared excess and reported to the General Services Administration. Appropriate

### 36 CFR Ch. XII (7-1-03 Edition)

instructions shall be issued to the recipient by the NHPRC.

(b) Exempt property. When statutory authority exists, the NHPRC has the option to vest title to property acquired with Federal funds in the recipient without further obligation to the Federal Government and under conditions the NHPRC considers appropriate. Such property is "exempt property." Should the NHPRC not establish conditions, title to exempt property upon acquisition shall vest in the recipient without further obligation to the Federal Government.

### § 1210.34 Equipment.

(a) Title to equipment acquired by a recipient with NHPRC funds shall vest in the recipient, subject to conditions of this section.

(b) The recipient shall not use equipment acquired with NHPRC funds to provide services to non-Federal outside organizations for a fee that is less than private companies charge for equivalent services, unless specifically authorized by Federal statute, for as long as the Federal Government retains an interest in the equipment.

(c) The recipient shall use the equipment in the project or program for which it was acquired as long as needed, whether or not the project or program continues to be supported by Federal funds and shall not encumber the property without approval of the NHPRC. When no longer needed for the original project or program, the recipient shall use the equipment in connection with its other federally-sponsored activities, in the following order of priority:

(1) Activities sponsored by the NHPRC which funded the original project, then

(2) Activities sponsored by other Federal awarding agencies.

(d) During the time that equipment is used on the project or program for which it was acquired, the recipient shall make it available for use on other projects or programs if such other use will not interfere with the work on the project or program for which the equipment was originally acquired. First preference for such other use shall be given to other projects or programs sponsored by the NHPRC that financed

the equipment; second preference shall be given to projects or programs sponsored by other Federal awarding agencies. If the equipment is owned by the Federal Government, use on other activities not sponsored by the Federal Government shall be permissible if authorized by the NHPRC. User charges shall be treated as program income.

(e) When acquiring replacement equipment, the recipient may use the equipment to be replaced as trade-in or sell the equipment and use the proceeds to offset the costs of the replacement equipment subject to the approval of the NHPRC.

(f) The recipient's property management standards for equipment acquired with Federal funds and federally-owned equipment shall include all of the following.

(1) Equipment records shall be maintained accurately and shall include the following information.

(i) A description of the equipment.

(ii) Manufacturer's serial number, model number, Federal stock number, national stock number, or other identification number.

(iii) Source of the equipment, including the award number.

(iv) Whether title vests in the recipient or the Federal Government.

(v) Acquisition date (or date received, if the equipment was furnished by the Federal Government) and cost.

(vi) Information from which one can calculate the percentage of Federal participation in the cost of the equipment (not applicable to equipment furnished by the Federal Government).

(vii) Location and condition of the equipment and the date the information was reported.

(viii) Unit acquisition cost.

(ix) Ultimate disposition data, including date of disposal and sales price or the method used to determine current fair market value where a recipient compensates the NHPRC for its share.

(2) Equipment owned by the Federal Government shall be identified to indicate Federal ownership.

(3) A physical inventory of equipment shall be taken and the results reconciled with the equipment records at least once every two years. Any differences between quantities deter-

mined by the physical inspection and those shown in the accounting records shall be investigated to determine the causes of the difference. The recipient shall, in connection with the inventory, verify the existence, current utilization, and continued need for the equipment.

(4) A control system shall be in effect to insure adequate safeguards to prevent loss, damage, or theft of the equipment. Any loss, damage, or theft of equipment shall be investigated and fully documented; if the equipment was owned by the Federal Government, the recipient shall promptly notify the NHPRC.

(5) Adequate maintenance procedures shall be implemented to keep the equipment in good condition.

(6) Where the recipient is authorized or required to sell the equipment, proper sales procedures shall be established which provide for competition to the extent practicable and result in the highest possible return.

(g) When the recipient no longer needs the equipment, the equipment may be used for other activities in accordance with the following standards. For equipment with a current per unit fair market value of \$5,000 or more, the recipient may retain the equipment for other uses provided that compensation is made to the NHPRC or its successor. The amount of compensation shall be computed by applying the percentage of Federal participation in the cost of the original project or program to the current fair market value of the equipment. If the recipient has no need for the equipment, the recipient shall request disposition instructions from the NHPRC. The NHPRC shall determine whether the equipment can be used to meet the NHPRC's requirements. If no requirement exists within the NHPRC, the availability of the equipment shall be reported to the General Services Administration by the NHPRC to determine whether a requirement for the equipment exists in other Federal agencies. The NHPRC shall issue instructions to the recipient no later than 120 calendar days after the recipient's request and the following procedures shall govern.

(1) If so instructed or if disposition instructions are not issued within 120

**§ 1210.35**

**36 CFR Ch. XII (7-1-03 Edition)**

calendar days after the recipient's request, the recipient shall sell the equipment and reimburse the NHPRC an amount computed by applying to the sales proceeds the percentage of Federal participation in the cost of the original project or program. However, the recipient shall be permitted to deduct and retain from the Federal share \$500 or ten percent of the proceeds, whichever is less, for the recipient's selling and handling expenses.

(2) If the recipient is instructed to ship the equipment elsewhere, the recipient shall be reimbursed by the Federal Government by an amount which is computed by applying the percentage of the recipient's participation in the cost of the original project or program to the current fair market value of the equipment, plus any reasonable shipping or interim storage costs incurred.

(3) If the recipient is instructed to otherwise dispose of the equipment, the recipient shall be reimbursed by the NHPRC for such costs incurred in its disposition.

(4) The NHPRC reserves the right to transfer the title to the Federal Government or to a third party named by the Federal Government when such third party is otherwise eligible under existing statutes. Such transfer shall be subject to the following standards.

(i) The equipment shall be appropriately identified in the award or otherwise made known to the recipient in writing.

(ii) The NHPRC shall issue disposition instructions within 120 calendar days after receipt of a final inventory. The final inventory shall list all equipment acquired with grant funds and federally-owned equipment. If the NHPRC fails to issue disposition instructions within the 120 calendar day period, the recipient shall apply the standards of this section, as appropriate.

(iii) When the NHPRC exercises its right to take title, the equipment shall be subject to the provisions for federally-owned equipment.

**§ 1210.35 Supplies and other expendable property.**

(a) Title to supplies and other expendable property shall vest in the re-

ipient upon acquisition. If there is a residual inventory of unused supplies exceeding \$5,000 in total aggregate value upon termination or completion of the project or program and the supplies are not needed for any other federally-sponsored project or program, the recipient shall retain the supplies for use on non-Federal sponsored activities or sell them, but shall, in either case, compensate the NHPRC for its share. The amount of compensation shall be computed in the same manner as for equipment.

(b) The recipient shall not use supplies acquired with NHPRC funds to provide services to non-Federal outside organizations for a fee that is less than private companies charge for equivalent services, unless specifically authorized by Federal statute as long as the Federal Government retains an interest in the supplies.

**§ 1210.36 Intangible property.**

(a) The recipient may copyright any work that is subject to copyright and was developed, or for which ownership was purchased, under an award. The NHPRC reserves a royalty-free, non-exclusive and irrevocable right to reproduce, publish, or otherwise use the work for Federal purposes, and to authorize others to do so.

(b) Recipients are subject to applicable regulations governing patents and inventions, including government-wide regulations issued by the Department of Commerce at 37 CFR Part 401, "Rights to Inventions Made by Non-profit Organizations and Small Business Firms Under Government Grants, Contracts and Cooperative Agreements."

(c) The Federal Government has the right to:

(1) Obtain, reproduce, publish or otherwise use the data first produced under an award; and

(2) Authorize others to receive, reproduce, publish, or otherwise use such data for Federal purposes.

(d) (1) In addition, in response to a Freedom of Information Act (FOIA) request for research data relating to published research findings produced under an award that were used by the Federal Government in developing an agency action that has the force and effect of

law, the NHPRC shall request, and the recipient shall provide, within a reasonable time, the research data so that they can be made available to the public through the procedures established under the FOIA. If the NHPRC obtains the research data solely in response to a FOIA request, the agency may charge the requester a reasonable fee equaling the full incremental cost of obtaining the research data. This fee should reflect costs incurred by the agency, the recipient, and applicable subrecipients. This fee is in addition to any fees the agency may assess under the FOIA (5 U.S.C. 552(a)(4)(A)).

(2) The following definitions apply for purposes of this paragraph (d):

(i) *Research data* is defined as the recorded factual material commonly accepted in the scientific community as necessary to validate research findings, but not any of the following: preliminary analyses, drafts of scientific papers, plans for future research, peer reviews, or communications with colleagues. This "recorded" material excludes physical objects (e.g., laboratory samples). *Research data* also do not include:

(A) Trade secrets, commercial information, materials necessary to be held confidential by a researcher until they are published, or similar information which is protected under law; and

(B) Personnel and medical information and similar information the disclosure of which would constitute a clearly unwarranted invasion of personal privacy, such as information that could be used to identify a particular person in a research study.

(ii) *Published* is defined as either when:

(A) Research findings are published in a peer-reviewed scientific or technical journal; or

(B) A Federal agency publicly and officially cites the research findings in support of an agency action that has the force and effect of law.

(iii) *Used by the Federal Government in developing an agency action that has the force and effect of law* is defined as when an agency publicly and officially cites the research findings in support of an agency action that has the force and effect of law.

(e) Title to intangible property and debt instruments acquired under an award or subaward vests upon acquisition in the recipient. The recipient shall use that property for the originally-authorized purpose, and the recipient shall not encumber the property without approval of the NHPRC. When no longer needed for the originally authorized purpose, disposition of the intangible property shall occur in accordance with the provisions of § 1210.34(g).

[60 FR 53515, Oct. 16, 1995, as amended at 65 FR 14407, 14417, Mar. 16, 2000]

#### § 1210.37 Property trust relationship.

Real property, equipment, intangible property and debt instruments that are acquired or improved with NHPRC funds shall be held in trust by the recipient as trustee for the beneficiaries of the project or program under which the property was acquired or improved. The NHPRC may require recipients to record liens or other appropriate notices of record to indicate that personal or real property has been acquired or improved with Federal funds and that use and disposition conditions apply to the property.

#### PROCUREMENT STANDARDS

#### § 1210.40 Purpose of procurement standards.

Sections 1210.41 through 1210.48 set forth standards for use by recipients in establishing procedures for the procurement of supplies and other expendable property, equipment, real property and other services with NHPRC funds. These standards are furnished to ensure that such materials and services are obtained in an effective manner and in compliance with the provisions of applicable Federal statutes and executive orders. No additional procurement standards or requirements shall be imposed by the NHPRC upon recipients, unless specifically required by Federal statute or executive order or approved by OMB.

#### § 1210.41 Recipient responsibilities.

The standards contained in this section do not relieve the recipient of the contractual responsibilities arising under its contract(s). The recipient is

## § 1210.42

the responsible authority, without recourse to the NHPRC, regarding the settlement and satisfaction of all contractual and administrative issues arising out of procurements entered into in support of an award or other agreement. This includes disputes, claims, protests of award, source evaluation or other matters of a contractual nature. Matters concerning violation of statute are to be referred to such Federal, State or local authority as may have proper jurisdiction.

### § 1210.42 Codes of conduct.

The recipient shall maintain written standards of conduct governing the performance of its employees engaged in the award and administration of contracts. No employee, officer, or agent shall participate in the selection, award, or administration of a contract supported by Federal funds if a real or apparent conflict of interest would be involved. Such a conflict would arise when the employee, officer, or agent, any member of his or her immediate family, his or her partner, or an organization which employs or is about to employ any of the parties indicated herein, has a financial or other interest in the firm selected for an award. The officers, employees, and agents of the recipient shall neither solicit nor accept gratuities, favors, or anything of monetary value from contractors, or parties to subagreements. However, recipients may set standards for situations in which the financial interest is not substantial or the gift is an unsolicited item of nominal value. The standards of conduct shall provide for disciplinary actions to be applied for violations of such standards by officers, employees, or agents of the recipient.

### § 1210.43 Competition.

All procurement transactions shall be conducted in a manner to provide, to the maximum extent practical, open and free competition. The recipient shall be alert to organizational conflicts of interest as well as noncompetitive practices among contractors that may restrict or eliminate competition or otherwise restrain trade. In order to ensure objective contractor performance and eliminate unfair competitive

## 36 CFR Ch. XII (7-1-03 Edition)

advantage, contractors that develop or draft specifications, requirements, statements of work, invitations for bids and/or requests for proposals shall be excluded from competing for such procurements. Awards shall be made to the bidder or offeror whose bid or offer is responsive to the solicitation and is most advantageous to the recipient, price, quality and other factors considered. Solicitations shall clearly set forth all requirements that the bidder or offeror shall fulfill in order for the bid or offer to be evaluated by the recipient. Any and all bids or offers may be rejected when it is in the recipient's interest to do so.

### § 1210.44 Procurement procedures.

(a) All recipients shall establish written procurement procedures. These procedures shall provide for, at a minimum, that paragraphs (a) (1), (2) and (3) of this section apply.

(1) Recipients avoid purchasing unnecessary items.

(2) Where appropriate, an analysis is made of lease and purchase alternatives to determine which would be the most economical and practical procurement for the Federal Government.

(3) Solicitations for goods and services provide for all of the following.

(i) A clear and accurate description of the technical requirements for the material, product or service to be procured. In competitive procurements, such a description shall not contain features which unduly restrict competition.

(ii) Requirements which the bidder/offeror must fulfill and all other factors to be used in evaluating bids or proposals.

(iii) A description, whenever practicable, of technical requirements in terms of functions to be performed or performance required, including the range of acceptable characteristics or minimum acceptable standards.

(iv) The specific features of "brand name or equal" descriptions that bidders are required to meet when such items are included in the solicitation.

(v) The acceptance, to the extent practicable and economically feasible, of products and services dimensioned in the metric system of measurement.



(vi) Preference, to the extent practicable and economically feasible, for products and services that conserve natural resources and protect the environment and are energy efficient.

(b) Positive efforts shall be made by recipients to utilize small businesses, minority-owned firms, and women's business enterprises, whenever possible. Recipients of Federal awards shall take all of the following steps to further this goal.

(1) Ensure that small businesses, minority-owned firms, and women's business enterprises are used to the fullest extent practicable.

(2) Make information on forthcoming opportunities available and arrange time frames for purchases and contracts to encourage and facilitate participation by small businesses, minority-owned firms, and women's business enterprises.

(3) Consider in the contract process whether firms competing for larger contracts intend to subcontract with small businesses, minority-owned firms, and women's business enterprises.

(4) Encourage contracting with consortiums of small businesses, minority-owned firms and women's business enterprises when a contract is too large for one of these firms to handle individually.

(5) Use the services and assistance, as appropriate, of such organizations as the Small Business Administration and the Department of Commerce's Minority Business Development Agency in the solicitation and utilization of small businesses, minority-owned firms and women's business enterprises.

(c) The type of procuring instruments used (e.g., fixed price contracts, cost reimbursable contracts, purchase orders, and incentive contracts) shall be determined by the recipient but shall be appropriate for the particular procurement and for promoting the best interest of the program or project involved. The "cost-plus-a-percentage-of-cost" or "percentage of construction cost" methods of contracting shall not be used.

(d) Contracts shall be made only with responsible contractors who possess the potential ability to perform successfully under the terms and condi-

tions of the proposed procurement. Consideration shall be given to such matters as contractor integrity, record of past performance, financial and technical resources or accessibility to other necessary resources. In certain circumstances, contracts with certain parties are restricted by NARA implementation of E.O.s 12549 and 12689, "Debarment and Suspension" (36 CFR Part 1209).

(e) Recipients shall, on request, make available for the NHPRC, pre-award review and procurement documents, such as request for proposals or invitations for bids, independent cost estimates, etc., when any of the following conditions apply.

(1) A recipient's procurement procedures or operation fails to comply with the procurement standards in the NHPRC's implementation of this part.

(2) The procurement is expected to exceed the small purchase threshold fixed at 41 U.S.C. 403 (11) (currently \$25,000) and is to be awarded without competition or only one bid or offer is received in response to a solicitation.

(3) The procurement, which is expected to exceed the small purchase threshold, specifies a "brand name" product.

(4) The proposed award over the small purchase threshold is to be awarded to other than the apparent low bidder under a sealed bid procurement.

(5) A proposed contract modification changes the scope of a contract or increases the contract amount by more than the amount of the small purchase threshold.

#### § 1210.45 Cost and price analysis.

Some form of cost or price analysis shall be made and documented in the procurement files in connection with every procurement action. Price analysis may be accomplished in various ways, including the comparison of price quotations submitted, market prices and similar indicia, together with discounts. Cost analysis is the review and evaluation of each element of cost to determine reasonableness, allocability and allowability.

## § 1210.46

### § 1210.46 Procurement records.

Procurement records and files for purchases in excess of the small purchase threshold shall include the following at a minimum:

- (a) Basis for contractor selection,
- (b) Justification for lack of competition when competitive bids or offers are not obtained, and
- (c) Basis for award cost or price.

### § 1210.47 Contract administration.

A system for contract administration shall be maintained to ensure contractor conformance with the terms, conditions and specifications of the contract and to ensure adequate and timely follow up of all purchases. Recipients shall evaluate contractor performance and document, as appropriate, whether contractors have met the terms, conditions and specifications of the contract.

### § 1210.48 Contract provisions.

The recipient shall include, in addition to provisions to define a sound and complete agreement, the following provisions in all contracts. The following provisions shall also be applied to subcontracts.

(a) Contracts in excess of the small purchase threshold shall contain contractual provisions or conditions that allow for administrative, contractual, or legal remedies in instances in which a contractor violates or breaches the contract terms, and provide for such remedial actions as may be appropriate.

(b) All contracts in excess of the small purchase threshold shall contain suitable provisions for termination by the recipient, including the manner by which termination shall be effected and the basis for settlement. In addition, such contracts shall describe conditions under which the contract may be terminated for default as well as conditions where the contract may be terminated because of circumstances beyond the control of the contractor.

(c) All negotiated contracts (except those for less than the small purchase threshold) awarded by recipients shall include a provision to the effect that the recipient, the NHPRC, the Comptroller General of the United States, or any of their duly authorized represent-

## 36 CFR Ch. XII (7-1-03 Edition)

atives, shall have access to any books, documents, papers and records of the contractor which are directly pertinent to a specific program for the purpose of making audits, examinations, excerpts and transcriptions.

(d) All contracts, including small purchases, awarded by recipients and their contractors shall contain the procurement provisions of Appendix A to this Part, as applicable.

### REPORTS AND RECORDS

### § 1210.50 Purpose of reports and records.

Sections 1210.51 through 1210.53 set forth the procedures for monitoring and reporting on the recipient's financial and program performance and the necessary standard reporting forms. They also set forth record retention requirements.

### § 1210.51 Monitoring and reporting program performance.

(a) Recipients are responsible for managing and monitoring each project, program, subaward, function or activity supported by the award. Recipients shall monitor subawards to ensure subrecipients have met the audit requirements as delineated in § 1210.26.

(b) Except as provided in paragraph (f) of this section, interim performance reports shall be submitted every six months and shall be due 30 days after the reporting period; final reports shall be due 90 calendar days after the end of the grant period.

(c) If inappropriate, a final performance report shall not be required after completion of the project.

(d) When required, performance reports shall generally contain, for each award, brief information on each of the following.

(1) A comparison of actual accomplishments with the goals and objectives established for the period, the findings of the investigator, or both. Whenever appropriate and the output of programs or projects can be readily quantified, such quantitative data should be related to cost data for computation of unit costs.

(2) Reasons why established goals were not met, if appropriate.

(3) Other pertinent information including, when appropriate, analysis and explanation of cost overruns or high unit costs.

(e) Recipients shall not be required to submit more than the original and two copies of performance reports.

(f) Recipients shall immediately notify the NHPRC of developments that have a significant impact on the award-supported activities. Also, notification shall be given in the case of problems, delays, or adverse conditions which materially impair the ability to meet the objectives of the award. This notification shall include a statement of the action taken or contemplated, and any assistance needed to resolve the situation.

(g) The NHPRC may make site visits, as needed.

(h) The NHPRC shall comply with clearance requirements of 5 CFR Part 1320 when requesting performance data from recipients.

**§ 1210.52 Financial reporting.**

(a) The following forms or such other forms as may be approved by OMB are authorized for obtaining financial information from recipients.

(1) SF-269 or SF-269A, Financial Status Report.

(i) The NHPRC requires recipients to use the SF-269 or SF-269A to report the status of funds for all nonconstruction projects or programs. The NHPRC may, however, have the option of not requiring the SF-269 or SF-269A when the SF-270, Request for Advance or Reimbursement, or SF-272, Report of Federal Cash Transactions, is determined to provide adequate information to meet its needs, except that a final SF-269 or SF-269A shall be required at the completion of the project when the SF-270 is used only for advances.

(ii) The report may be on a cash or accrual basis.

(iii) The NHPRC shall determine the frequency of the Financial Status Report for each project or program, considering the size and complexity of the particular project or program. However, the report shall not be required more frequently than quarterly or less frequently than annually. A final report shall be required at the completion of the agreement.

(iv) The NHPRC shall require recipients to submit the SF-269 or SF-269A (an original and no more than two copies) no later than 30 days after the end of each specified reporting period for quarterly and semi-annual reports, and 90 calendar days for annual and final reports. Extensions of reporting due dates may be approved by NHPRC upon request of the recipient.

(2) SF-272, Report of Federal Cash Transactions.

(i) When funds are advanced to recipients the NHPRC shall require each recipient to submit the SF-272 and, when necessary, its continuation sheet, SF-272a. The NHPRC shall use this report to monitor cash advanced to recipients and to obtain disbursement information for each agreement with the recipients.

(ii) The NHPRC may require forecasts of Federal cash requirements in the "Remarks" section of the report.

(iii) When practical and deemed necessary, the NHPRC may require recipients to report in the "Remarks" section the amount of cash advances received in excess of three days. Recipients shall provide short narrative explanations of actions taken to reduce the excess balances.

(iv) Recipients shall be required to submit not more than the original and two copies of the SF-272 15 calendar days following the end of each quarter. The NHPRC may require a monthly report from those recipients receiving advances totaling \$1 million or more per year.

(v) The NHPRC may waive the requirement for submission of the SF-272 for any one of the following reasons:

(A) When monthly advances do not exceed \$25,000 per recipient, provided that such advances are monitored through other forms contained in this section;

(B) If, in the NHPRC's opinion, the recipient's accounting controls are adequate to minimize excessive Federal advances; or,

(C) When the electronic payment mechanisms provide adequate data.

(b) When the NHPRC needs additional information or more frequent reports, the following shall be observed.

**§ 1210.53**

**36 CFR Ch. XII (7-1-03 Edition)**

(1) When additional information is needed to comply with legislative requirements, the NHPRC shall issue instructions to require recipients to submit such information under the "Remarks" section of the reports.

(2) When the NHPRC determines that a recipient's accounting system does not meet the standards in §1210.21, additional pertinent information to further monitor awards may be obtained upon written notice to the recipient until such time as the system is brought up to standard. The NHPRC, in obtaining this information, shall comply with report clearance requirements of 5 CFR Part 1320.

(3) The NHPRC is encouraged to shade out any line item on any report if not necessary.

(4) The NHPRC may accept the identical information from the recipients in machine readable format or computer printouts or electronic outputs in lieu of prescribed formats.

(5) The NHPRC may provide computer or electronic outputs to recipients when such expedites or contributes to the accuracy of reporting.

**§ 1210.53 Retention and access requirements for records.**

(a) This section sets forth requirements for record retention and access to records for awards to recipients. The NHPRC will not impose any other record retention or access requirements upon recipients.

(b) Financial records, supporting documents, statistical records, and all other records pertinent to an award shall be retained for a period of three years from the date of submission of the final expenditure report or, for awards that are renewed quarterly or annually, from the date of the submission of the quarterly or annual financial report, as authorized by the NHPRC. The only exceptions are the following.

(1) If any litigation, claim, or audit is started before the expiration of the 3-year period, the records shall be retained until all litigation, claims or audit findings involving the records have been resolved and final action taken.

(2) Records for real property and equipment acquired with NHPRC funds

shall be retained for 3 years after final disposition.

(3) When records are transferred to or maintained by the NHPRC, the 3-year retention requirement is not applicable to the recipient.

(4) Indirect cost rate proposals, cost allocations plans, etc. as specified in paragraph (g) of this section.

(c) Copies of original records may be substituted for the original records if authorized by the NHPRC.

(d) The NHPRC shall request transfer of certain records to its custody from recipients when it determines that the records possess long term retention value. However, in order to avoid duplicate recordkeeping, the NHPRC may make arrangements for recipients to retain any records that are continuously needed for joint use.

(e) The NHPRC, the Inspector General, Comptroller General of the United States, or any of their duly authorized representatives, have the right of timely and unrestricted access to any books, documents, papers, or other records of recipients that are pertinent to the awards, in order to make audits, examinations, excerpts, transcripts and copies of such documents. This right also includes timely and reasonable access to a recipient's personnel for the purpose of interview and discussion related to such documents. The rights of access in this paragraph are not limited to the required retention period, but shall last as long as records are retained.

(f) Unless required by statute, the NHPRC will place no restrictions on recipients that limit public access to the records of recipients that are pertinent to an award, except when the NHPRC can demonstrate that such records shall be kept confidential and would have been exempted from disclosure pursuant to the Freedom of Information Act (5 U.S.C. 552) if the records had belonged to the NHPRC.

(g) Indirect cost rate proposals, cost allocations plans, etc. Paragraphs (g)(1) and (g)(2) of this section apply to the following types of documents, and their supporting records: indirect cost rate computations or proposals, cost allocation plans, and any similar accounting computations of the rate at which a particular group of costs is chargeable

(such as computer usage chargeback rates or composite fringe benefit rates).

(1) If submitted for negotiation. If the recipient submits to the cognizant Federal agency or the subrecipient submits to the recipient the proposal, plan, or other computation to form the basis for negotiation of the rate, then the 3-year retention period for its supporting records starts on the date of such submission.

(2) If not submitted for negotiation. If the recipient is not required to submit to the NHPRC or the subrecipient is not required to submit to the recipient the proposal, plan, or other computation for negotiation purposes, then the 3-year retention period for the proposal, plan, or other computation and its supporting records starts at the end of the fiscal year (or other accounting period) covered by the proposal, plan, or other computation.

#### TERMINATION AND ENFORCEMENT

##### **§ 1210.60 Purpose of termination and enforcement.**

Sections 1210.61 and 1210.62 set forth uniform suspension, termination and enforcement procedures.

##### **§ 1210.61 Termination.**

(a) Awards may be terminated in whole or in part only if paragraphs (1), (2) or (3) of this section apply.

(1) By the NHPRC, if a recipient materially fails to comply with the terms and conditions of an award.

(2) By the NHPRC with the consent of the recipient, in which case the two parties shall agree upon the termination conditions, including the effective date and, in the case of partial termination, the portion to be terminated.

(3) By the recipient upon sending to the NHPRC written notification setting forth the reasons for such termination, the effective date, and, in the case of partial termination, the portion to be terminated. However, if the NHPRC determines in the case of partial termination that the reduced or modified portion of the grant will not accomplish the purposes for which the grant was made, it may terminate the

grant in its entirety under either paragraphs (a)(1) or (2) of this section.

(b) If costs are allowed under an award, the responsibilities of the recipient referred to in §1210.71(a), including those for property management as applicable, shall be considered in the termination of the award, and provision shall be made for continuing responsibilities of the recipient after termination, as appropriate.

##### **§ 1210.62 Enforcement.**

(a) Remedies for noncompliance. If a recipient materially fails to comply with the terms and conditions of an award, whether stated in a Federal statute, regulation, assurance, application, or notice of award, the NHPRC may, in addition to imposing any of the special conditions outlined in §1210.14, take one or more of the following actions, as appropriate in the circumstances.

(1) Temporarily withhold cash payments pending correction of the deficiency by the recipient or more severe enforcement action by the NHPRC.

(2) Disallow (that is, deny both use of funds and any applicable matching credit for) all or part of the cost of the activity or action not in compliance.

(3) Wholly or partly suspend or terminate the current award.

(4) Withhold further awards for the project or program.

(5) Take other remedies that may be legally available.

(b) Hearings and appeals. In taking an enforcement action, the NHPRC shall provide the recipient an opportunity for hearing, appeal, or other administrative proceeding to which the recipient is entitled under any statute or regulation applicable to the action involved.

(c) Effects of suspension and termination. Costs of a recipient resulting from obligations incurred by the recipient during a suspension or after termination of an award are not allowable unless the NHPRC expressly authorizes them in the notice of suspension or termination or subsequently. Other recipient costs during suspension or after termination which are necessary and not reasonably avoidable are allowable if paragraphs (c)(1) and (2) of this section apply.

## § 1210.70

(1) The costs result from obligations which were properly incurred by the recipient before the effective date of suspension or termination, are not in anticipation of it, and in the case of a termination, are noncancellable.

(2) The costs would be allowable if the award were not suspended or expired normally at the end of the funding period in which the termination takes effect.

(d) Relationship to debarment and suspension. The enforcement remedies identified in this section, including suspension and termination, do not preclude a recipient from being subject to debarment and suspension under E.O.s 12549 and 12689 and NARA implementing regulations (see § 1210.13).

### Subpart D—After-the-Award Requirements

#### § 1210.70 Purpose.

Sections 1210.71 through 1210.73 contain closeout procedures and other procedures for subsequent disallowances and adjustments.

#### § 1210.71 Closeout procedures.

(a) Recipients shall submit, within 90 calendar days after the date of completion of the award, all financial, performance, and other reports as required by the terms and conditions of the award. The NHPRC may approve extensions when requested by the recipient.

(b) Unless the NHPRC authorizes an extension, a recipient shall liquidate all obligations incurred under the award not later than 90 calendar days after the funding period or the date of completion as specified in the terms and conditions of the award or in agency implementing instructions.

(c) The NHPRC shall make prompt payments to a recipient for allowable reimbursable costs under the award being closed out.

(d) The recipient shall promptly refund any balances of unobligated cash that the NHPRC has advanced or paid and that is not authorized to be retained by the recipient for use in other projects. OMB Circular A-129 governs unreturned amounts that become delinquent debts.

(e) When authorized by the terms and conditions of the award, the NHPRC

## 36 CFR Ch. XII (7-1-03 Edition)

shall make a settlement for any upward or downward adjustments to the Federal share of costs after closeout reports are received.

(f) The recipient shall account for any real and personal property acquired with Federal funds or received from the Federal Government in accordance with §§ 1210.31 through 1210.37.

(g) In the event a final audit has not been performed prior to the closeout of an award, the NHPRC shall retain the right to recover an appropriate amount after fully considering the recommendations on disallowed costs resulting from the final audit.

#### § 1210.72 Subsequent adjustments and continuing responsibilities.

(a) The closeout of an award does not affect any of the following.

(1) The right of the NHPRC to disallow costs and recover funds on the basis of a later audit or other review.

(2) The obligation of the recipient to return any funds due as a result of later refunds, corrections, or other transactions.

(3) Audit requirements in § 1210.26.

(4) Property management requirements in §§ 1210.31 through 1210.37.

(5) Records retention as required in § 1210.53.

(b) After closeout of an award, a relationship created under an award may be modified or ended in whole or in part with the consent of the NHPRC and the recipient, provided the responsibilities of the recipient referred to in § 1210.73(a), including those for property management as applicable, are considered and provisions made for continuing responsibilities of the recipient, as appropriate.

#### § 1210.73 Collection of amounts due.

(a) Any funds paid to a recipient in excess of the amount to which the recipient is finally determined to be entitled under the terms and conditions of the award constitute a debt to the Federal Government. If not paid within a reasonable period after the demand for payment, the NHPRC may reduce the debt by:

(1) Making an administrative offset against other requests for reimbursements;

(2) Withholding advance payments otherwise due to the recipient; or

(3) Taking other action permitted by statute.

(b) Except as otherwise provided by law, the NHPRC shall charge interest on an overdue debt in accordance with 4 CFR Chapter II, "Federal Claims Collection Standards."

#### APPENDIX A TO PART 1210—CONTRACT PROVISIONS

All contracts, awarded by a recipient including small purchases, shall contain the following provisions as applicable:

1. Equal Employment Opportunity—All contracts shall contain a provision requiring compliance with E.O. 11246, "Equal Employment Opportunity," as amended by E.O. 11375, "Amending Executive Order 11246 Relating to Equal Employment Opportunity," and as supplemented by regulations at 41 CFR part 60, "Office of Federal Contract Compliance Programs, Equal Employment Opportunity, Department of Labor."

2. Copeland "Anti-Kickback" Act (18 U.S.C. 874 and 40 U.S.C. 276c)—All contracts and subgrants in excess of \$2,000 for construction or repair awarded by recipients and subrecipients shall include a provision for compliance with the Copeland "Anti-Kickback" Act (18 U.S.C. 874), as supplemented by Department of Labor regulations (29 CFR part 3, "Contractors and Subcontractors on Public Building or Public Work Financed in Whole or in Part by Loans or Grants from the United States"). The Act provides that each contractor or subrecipient shall be prohibited from inducing, by any means, any person employed in the construction, completion, or repair of public work, to give up any part of the compensation to which he is otherwise entitled. The recipient shall report all suspected or reported violations to the Federal awarding agency.

3. Davis-Bacon Act, as amended (40 U.S.C. 276a to a-7)—When required by Federal program legislation, all construction contracts awarded by the recipients and subrecipients of more than \$2,000 shall include a provision for compliance with the Davis-Bacon Act (40 U.S.C. 276a to a-7) and as supplemented by Department of Labor regulations (29 CFR part 5, "Labor Standards Provisions Applicable to Contracts Governing Federally Financed and Assisted Construction"). Under this Act, contractors shall be required to pay wages to laborers and mechanics at a rate not less than the minimum wages specified in a wage determination made by the Secretary of Labor. In addition, contractors shall be required to pay wages not less than once a week. The recipient shall place a copy of the current prevailing wage determination issued by the Department of Labor in each

solicitation and the award of a contract shall be conditioned upon the acceptance of the wage determination. The recipient shall report all suspected or reported violations to the Federal awarding agency.

4. Contract Work Hours and Safety Standards Act (40 U.S.C. 327-333)—Where applicable, all contracts awarded by recipients in excess of \$2,000 for construction contracts and in excess of \$2,500 for other contracts that involve the employment of mechanics or laborers shall include a provision for compliance with Sections 102 and 107 of the Contract Work Hours and Safety Standards Act (40 U.S.C. 327-333), as supplemented by Department of Labor regulations (29 CFR part 5). Under Section 102 of the Act, each contractor shall be required to compute the wages of every mechanic and laborer on the basis of a standard work week of 40 hours. Work in excess of the standard work week is permissible provided that the worker is compensated at a rate of not less than 1½ times the basic rate of pay for all hours worked in excess of 40 hours in the work week. Section 107 of the Act is applicable to construction work and provides that no laborer or mechanic shall be required to work in surroundings or under working conditions which are unsanitary, hazardous or dangerous. These requirements do not apply to the purchases of supplies or materials or articles ordinarily available on the open market, or contracts for transportation or transmission of intelligence.

5. Rights to Inventions Made Under a Contract or Agreement—Contracts or agreements for the performance of experimental, developmental, or research work shall provide for the rights of the Federal Government and the recipient in any resulting invention in accordance with 37 CFR part 401, "Rights to Inventions Made by Nonprofit Organizations and Small Business Firms Under Government Grants, Contracts and Cooperative Agreements," and any implementing regulations issued by the awarding agency.

6. Clean Air Act (42 U.S.C. 7401 *et seq.*) and the Federal Water Pollution Control Act (33 U.S.C. 1251 *et seq.*), as amended—Contracts and subgrants of amounts in excess of \$100,000 shall contain a provision that requires the recipient to agree to comply with all applicable standards, orders or regulations issued pursuant to the Clean Air Act (42 U.S.C. 7401 *et seq.*) and the Federal Water Pollution Control Act as amended (33 U.S.C. 1251 *et seq.*). Violations shall be reported to the Federal awarding agency and the Regional Office of the Environmental Protection Agency (EPA).

7. Byrd Anti-Lobbying Amendment (31 U.S.C. 1352)—Contractors who apply or bid for an award of \$100,000 or more shall file the required certification. Each tier certifies to the tier above that it will not and has not used Federal appropriated funds to pay any

person or organization for influencing or attempting to influence an officer or employee of any agency, a member of Congress, officer or employee of Congress, or an employee of a member of Congress in connection with obtaining any Federal contract, grant or any other award covered by 31 U.S.C. 1352. Each tier shall also disclose any lobbying with non-Federal funds that takes place in connection with obtaining any Federal award. Such disclosures are forwarded from tier to tier up to the recipient.

8. Debarment and Suspension (E.O. 12549 and E.O. 12689)—No contract shall be made to parties listed on the General Services Administration's List of Parties Excluded from Federal Procurement or Nonprocurement Programs in accordance with E.O. 12549 and E.O. 12689, "Debarment and Suspension." This list contains the names of parties debarred, suspended, or otherwise excluded by agencies, and contractors declared ineligible under statutory or regulatory authority other than E.O. 12549. Contractors with awards that exceed the small purchase threshold shall provide the required certification regarding its exclusion status and that of its principal employees.

## **PART 1211—NONDISCRIMINATION ON THE BASIS OF SEX IN EDUCATION PROGRAMS OR ACTIVITIES RECEIVING FEDERAL FINANCIAL ASSISTANCE**

### **Subpart A—Introduction**

- Sec.
- 1211.100 Purpose and effective date.
  - 1211.105 Definitions.
  - 1211.110 Remedial and affirmative action and self-evaluation.
  - 1211.115 Assurance required.
  - 1211.120 Transfers of property.
  - 1211.125 Effect of other requirements.
  - 1211.130 Effect of employment opportunities.
  - 1211.135 Designation of responsible employee and adoption of grievance procedures.
  - 1211.140 Dissemination of policy.

### **Subpart B—Coverage**

- 1211.200 Application.
- 1211.205 Educational institutions and other entities controlled by religious organizations.
- 1211.210 Military and merchant marine educational institutions.
- 1211.215 Membership practices of certain organizations.
- 1211.220 Admissions.
- 1211.225 Educational institutions eligible to submit transition plans.
- 1211.230 Transition plans.

- 1211.235 Statutory amendments.

### **Subpart C—Discrimination on the Basis of Sex in Admission and Recruitment Prohibited**

- 1211.300 Admission.
- 1211.305 Preference in admission.
- 1211.310 Recruitment.

### **Subpart D—Discrimination on the Basis of Sex in Education Programs or Activities Prohibited**

- 1211.400 Education programs or activities.
- 1211.405 Housing.
- 1211.410 Comparable facilities.
- 1211.415 Access to course offerings.
- 1211.420 Access to schools operated by LEAs.
- 1211.425 Counseling and use of appraisal and counseling materials.
- 1211.430 Financial assistance.
- 1211.435 Employment assistance to students.
- 1211.440 Health and insurance benefits and services.
- 1211.445 Marital or parental status.
- 1211.450 Athletics.
- 1211.455 Textbooks and curricular material.

### **Subpart E—Discrimination on the Basis of Sex in Employment in Education Programs or Activities Prohibited**

- 1211.500 Employment.
- 1211.505 Employment criteria.
- 1211.510 Recruitment.
- 1211.515 Compensation.
- 1211.520 Job classification and structure.
- 1211.525 Fringe benefits.
- 1211.530 Marital or parental status.
- 1211.535 Effect of state or local law or other requirements.
- 1211.540 Advertising.
- 1211.545 Pre-employment inquiries.
- 1211.550 Sex as a bona fide occupational qualification.

### **Subpart F—Procedures**

- 1211.600 Notice of covered programs.
- 1211.605 Compliance information.
- 1211.610 Conduct of investigations.
- 1211.615 Procedure for effecting compliance.
- 1211.620 Hearings.
- 1211.625 Decisions and notices.
- 1211.630 Judicial review.
- 1211.635 Forms and instructions; coordination.

AUTHORITY: 20 U.S.C. 1681, 1682, 1683, 1685, 1686, 1687, 1688.

SOURCE: 65 FR 52865, 52886, Aug. 30, 2000, unless otherwise noted.



**Subpart A—Introduction****§ 1211.100 Purpose and effective date.**

The purpose of these Title IX regulations is to effectuate Title IX of the Education Amendments of 1972, as amended (except sections 904 and 906 of those Amendments) (20 U.S.C. 1681, 1682, 1683, 1685, 1686, 1687, 1688), which is designed to eliminate (with certain exceptions) discrimination on the basis of sex in any education program or activity receiving Federal financial assistance, whether or not such program or activity is offered or sponsored by an educational institution as defined in these Title IX regulations. The effective date of these Title IX regulations shall be September 29, 2000.

**§ 1211.105 Definitions.**

As used in these Title IX regulations, the term:

*Administratively separate unit* means a school, department, or college of an educational institution (other than a local educational agency) admission to which is independent of admission to any other component of such institution.

*Admission* means selection for part-time, full-time, special, associate, transfer, exchange, or any other enrollment, membership, or matriculation in or at an education program or activity operated by a recipient.

*Applicant* means one who submits an application, request, or plan required to be approved by an official of the Federal agency that awards Federal financial assistance, or by a recipient, as a condition to becoming a recipient.

*Designated agency official* means Executive Director, National Historical Publications and Records Commission.

*Educational institution* means a local educational agency (LEA) as defined by 20 U.S.C. 8801(18), a preschool, a private elementary or secondary school, or an applicant or recipient that is an institution of graduate higher education, an institution of undergraduate higher education, an institution of professional education, or an institution of vocational education, as defined in this section.

*Federal financial assistance* means any of the following, when authorized or extended under a law administered by

the Federal agency that awards such assistance:

(1) A grant or loan of Federal financial assistance, including funds made available for:

(i) The acquisition, construction, renovation, restoration, or repair of a building or facility or any portion thereof; and

(ii) Scholarships, loans, grants, wages, or other funds extended to any entity for payment to or on behalf of students admitted to that entity, or extended directly to such students for payment to that entity.

(2) A grant of Federal real or personal property or any interest therein, including surplus property, and the proceeds of the sale or transfer of such property, if the Federal share of the fair market value of the property is not, upon such sale or transfer, properly accounted for to the Federal Government.

(3) Provision of the services of Federal personnel.

(4) Sale or lease of Federal property or any interest therein at nominal consideration, or at consideration reduced for the purpose of assisting the recipient or in recognition of public interest to be served thereby, or permission to use Federal property or any interest therein without consideration.

(5) Any other contract, agreement, or arrangement that has as one of its purposes the provision of assistance to any education program or activity, except a contract of insurance or guaranty.

*Institution of graduate higher education* means an institution that:

(1) Offers academic study beyond the bachelor of arts or bachelor of science degree, whether or not leading to a certificate of any higher degree in the liberal arts and sciences;

(2) Awards any degree in a professional field beyond the first professional degree (regardless of whether the first professional degree in such field is awarded by an institution of undergraduate higher education or professional education); or

(3) Awards no degree and offers no further academic study, but operates ordinarily for the purpose of facilitating research by persons who have received the highest graduate degree in any field of study.

§ 1211.110

36 CFR Ch. XII (7-1-03 Edition)

*Institution of professional education* means an institution (except any institution of undergraduate higher education) that offers a program of academic study that leads to a first professional degree in a field for which there is a national specialized accrediting agency recognized by the Secretary of Education.

*Institution of undergraduate higher education* means:

(1) An institution offering at least two but less than four years of college-level study beyond the high school level, leading to a diploma or an associate degree, or wholly or principally creditable toward a baccalaureate degree; or

(2) An institution offering academic study leading to a baccalaureate degree; or

(3) An agency or body that certifies credentials or offers degrees, but that may or may not offer academic study.

*Institution of vocational education* means a school or institution (except an institution of professional or graduate or undergraduate higher education) that has as its primary purpose preparation of students to pursue a technical, skilled, or semiskilled occupation or trade, or to pursue study in a technical field, whether or not the school or institution offers certificates, diplomas, or degrees and whether or not it offers full-time study.

*Recipient* means any State or political subdivision thereof, or any instrumentality of a State or political subdivision thereof, any public or private agency, institution, or organization, or other entity, or any person, to whom Federal financial assistance is extended directly or through another recipient and that operates an education program or activity that receives such assistance, including any subunit, successor, assignee, or transferee thereof.

*Student* means a person who has gained admission.

*Title IX* means Title IX of the Education Amendments of 1972, Public Law 92-318, 86 Stat. 235, 373 (codified as amended at 20 U.S.C. 1681-1688) (except sections 904 and 906 thereof), as amended by section 3 of Public Law 93-568, 88 Stat. 1855, by section 412 of the Education Amendments of 1976, Public Law 94-482, 90 Stat. 2234, and by Section 3 of

Public Law 100-259, 102 Stat. 28, 28-29 (20 U.S.C. 1681, 1682, 1683, 1685, 1686, 1687, 1688).

*Title IX regulations* means the provisions set forth at 36 CFR 1211.100 through 1211.635.

*Transition plan* means a plan subject to the approval of the Secretary of Education pursuant to section 901(a)(2) of the Education Amendments of 1972, 20 U.S.C. 1681(a)(2), under which an educational institution operates in making the transition from being an educational institution that admits only students of one sex to being one that admits students of both sexes without discrimination.

§ 1211.110 Remedial and affirmative action and self-evaluation.

(a) *Remedial action.* If the designated agency official finds that a recipient has discriminated against persons on the basis of sex in an education program or activity, such recipient shall take such remedial action as the designated agency official deems necessary to overcome the effects of such discrimination.

(b) *Affirmative action.* In the absence of a finding of discrimination on the basis of sex in an education program or activity, a recipient may take affirmative action consistent with law to overcome the effects of conditions that resulted in limited participation therein by persons of a particular sex. Nothing in these Title IX regulations shall be interpreted to alter any affirmative action obligations that a recipient may have under Executive Order 11246, 3 CFR, 1964-1965 Comp., p. 339; as amended by Executive Order 11375, 3 CFR, 1966-1970 Comp., p. 684; as amended by Executive Order 11478, 3 CFR, 1966-1970 Comp., p. 803; as amended by Executive Order 12086, 3 CFR, 1978 Comp., p. 230; as amended by Executive Order 12107, 3 CFR, 1978 Comp., p. 264.

(c) *Self-evaluation.* Each recipient education institution shall, within one year of September 29, 2000:

(1) Evaluate, in terms of the requirements of these Title IX regulations, its current policies and practices and the effects thereof concerning admission of students, treatment of students, and employment of both academic and non-

academic personnel working in connection with the recipient's education program or activity;

(2) Modify any of these policies and practices that do not or may not meet the requirements of these Title IX regulations; and

(3) Take appropriate remedial steps to eliminate the effects of any discrimination that resulted or may have resulted from adherence to these policies and practices.

(d) *Availability of self-evaluation and related materials.* Recipients shall maintain on file for at least three years following completion of the evaluation required under paragraph (c) of this section, and shall provide to the designated agency official upon request, a description of any modifications made pursuant to paragraph (c)(2) of this section and of any remedial steps taken pursuant to paragraph (c)(3) of this section.

**§ 1211.115 Assurance required.**

(a) *General.* Either at the application stage or the award stage, Federal agencies must ensure that applications for Federal financial assistance or awards of Federal financial assistance contain, be accompanied by, or be covered by a specifically identified assurance from the applicant or recipient, satisfactory to the designated agency official, that each education program or activity operated by the applicant or recipient and to which these Title IX regulations apply will be operated in compliance with these Title IX regulations. An assurance of compliance with these Title IX regulations shall not be satisfactory to the designated agency official if the applicant or recipient to whom such assurance applies fails to commit itself to take whatever remedial action is necessary in accordance with § 1211.110(a) to eliminate existing discrimination on the basis of sex or to eliminate the effects of past discrimination whether occurring prior to or subsequent to the submission to the designated agency official of such assurance.

(b) *Duration of obligation.* (1) In the case of Federal financial assistance extended to provide real property or structures thereon, such assurance shall obligate the recipient or, in the

case of a subsequent transfer, the transferee, for the period during which the real property or structures are used to provide an education program or activity.

(2) In the case of Federal financial assistance extended to provide personal property, such assurance shall obligate the recipient for the period during which it retains ownership or possession of the property.

(3) In all other cases such assurance shall obligate the recipient for the period during which Federal financial assistance is extended.

(c) *Form.* (1) The assurances required by paragraph (a) of this section, which may be included as part of a document that addresses other assurances or obligations, shall include that the applicant or recipient will comply with all applicable Federal statutes relating to nondiscrimination. These include but are not limited to: Title IX of the Education Amendments of 1972, as amended (20 U.S.C. 1681-1683, 1685-1688).

(2) The designated agency official will specify the extent to which such assurances will be required of the applicant's or recipient's subgrantees, contractors, subcontractors, transferees, or successors in interest.

**§ 1211.120 Transfers of property.**

If a recipient sells or otherwise transfers property financed in whole or in part with Federal financial assistance to a transferee that operates any education program or activity, and the Federal share of the fair market value of the property is not upon such sale or transfer properly accounted for to the Federal Government, both the transferor and the transferee shall be deemed to be recipients, subject to the provisions of §§ 1211.205 through 1211.235(a).

**§ 1211.125 Effect of other requirements.**

(a) *Effect of other Federal provisions.* The obligations imposed by these Title IX regulations are independent of, and do not alter, obligations not to discriminate on the basis of sex imposed by Executive Order 11246, 3 CFR, 1964-1965 Comp., p. 339; as amended by Executive Order 11375, 3 CFR, 1966-1970 Comp., p. 684; as amended by Executive

### § 1211.130

Order 11478, 3 CFR, 1966–1970 Comp., p. 803; as amended by Executive Order 12087, 3 CFR, 1978 Comp., p. 230; as amended by Executive Order 12107, 3 CFR, 1978 Comp., p. 264; sections 704 and 855 of the Public Health Service Act (42 U.S.C. 295m, 298b-2); Title VII of the Civil Rights Act of 1964 (42 U.S.C. 2000e *et seq.*); the Equal Pay Act of 1963 (29 U.S.C. 206); and any other Act of Congress or Federal regulation.

(b) *Effect of State or local law or other requirements.* The obligation to comply with these Title IX regulations is not obviated or alleviated by any State or local law or other requirement that would render any applicant or student ineligible, or limit the eligibility of any applicant or student, on the basis of sex, to practice any occupation or profession.

(c) *Effect of rules or regulations of private organizations.* The obligation to comply with these Title IX regulations is not obviated or alleviated by any rule or regulation of any organization, club, athletic or other league, or association that would render any applicant or student ineligible to participate or limit the eligibility or participation of any applicant or student, on the basis of sex, in any education program or activity operated by a recipient and that receives Federal financial assistance.

### § 1211.130 Effect of employment opportunities.

The obligation to comply with these Title IX regulations is not obviated or alleviated because employment opportunities in any occupation or profession are or may be more limited for members of one sex than for members of the other sex.

### § 1211.135 Designation of responsible employee and adoption of grievance procedures.

(a) *Designation of responsible employee.* Each recipient shall designate at least one employee to coordinate its efforts to comply with and carry out its responsibilities under these Title IX regulations, including any investigation of any complaint communicated to such recipient alleging its noncompliance with these Title IX regulations or alleging any actions that would be pro-

### 36 CFR Ch. XII (7–1–03 Edition)

hibited by these Title IX regulations. The recipient shall notify all its students and employees of the name, office address, and telephone number of the employee or employees appointed pursuant to this paragraph.

(b) *Complaint procedure of recipient.* A recipient shall adopt and publish grievance procedures providing for prompt and equitable resolution of student and employee complaints alleging any action that would be prohibited by these Title IX regulations.

### § 1211.140 Dissemination of policy.

(a) *Notification of policy.* (1) Each recipient shall implement specific and continuing steps to notify applicants for admission and employment, students and parents of elementary and secondary school students, employees, sources of referral of applicants for admission and employment, and all unions or professional organizations holding collective bargaining or professional agreements with the recipient, that it does not discriminate on the basis of sex in the educational programs or activities that it operates, and that it is required by Title IX and these Title IX regulations not to discriminate in such a manner. Such notification shall contain such information, and be made in such manner, as the designated agency official finds necessary to apprise such persons of the protections against discrimination assured them by Title IX and these Title IX regulations, but shall state at least that the requirement not to discriminate in education programs or activities extends to employment therein, and to admission thereto unless §§ 1211.300 through 1211.310 do not apply to the recipient, and that inquiries concerning the application of Title IX and these Title IX regulations to such recipient may be referred to the employee designated pursuant to § 1211.135, or to the designated agency official.

(2) Each recipient shall make the initial notification required by paragraph (a)(1) of this section within 90 days of September 29, 2000 or of the date these Title IX regulations first apply to such recipient, whichever comes later, which notification shall include publication in:

(i) Newspapers and magazines operated by such recipient or by student, alumnae, or alumni groups for or in connection with such recipient; and

(ii) Memoranda or other written communications distributed to every student and employee of such recipient.

(b) *Publications.* (1) Each recipient shall prominently include a statement of the policy described in paragraph (a) of this section in each announcement, bulletin, catalog, or application form that it makes available to any person of a type, described in paragraph (a) of this section, or which is otherwise used in connection with the recruitment of students or employees.

(2) A recipient shall not use or distribute a publication of the type described in paragraph (b)(1) of this section that suggests, by text or illustration, that such recipient treats applicants, students, or employees differently on the basis of sex except as such treatment is permitted by these Title IX regulations.

(c) *Distribution.* Each recipient shall distribute without discrimination on the basis of sex each publication described in paragraph (b)(1) of this section, and shall apprise each of its admission and employment recruitment representatives of the policy of non-discrimination described in paragraph (a) of this section, and shall require such representatives to adhere to such policy.

### Subpart B—Coverage

#### § 1211.200 Application.

Except as provided in §§ 1211.205 through 1211.235(a), these Title IX regulations apply to every recipient and to each education program or activity operated by such recipient that receives Federal financial assistance.

#### § 1211.205 Educational institutions and other entities controlled by religious organizations.

(a) *Exemption.* These Title IX regulations do not apply to any operation of an educational institution or other entity that is controlled by a religious organization to the extent that application of these Title IX regulations would not be consistent with the religious tenets of such organization.

(b) *Exemption claims.* An educational institution or other entity that wishes to claim the exemption set forth in paragraph (a) of this section shall do so by submitting in writing to the designated agency official a statement by the highest-ranking official of the institution, identifying the provisions of these Title IX regulations that conflict with a specific tenet of the religious organization.

#### § 1211.210 Military and merchant marine educational institutions.

These Title IX regulations do not apply to an educational institution whose primary purpose is the training of individuals for a military service of the United States or for the merchant marine.

#### § 1211.215 Membership practices of certain organizations.

(a) *Social fraternities and sororities.* These Title IX regulations do not apply to the membership practices of social fraternities and sororities that are exempt from taxation under section 501(a) of the Internal Revenue Code of 1954, 26 U.S.C. 501(a), the active membership of which consists primarily of students in attendance at institutions of higher education.

(b) *YMCA, YWCA, Girl Scouts, Boy Scouts, and Camp Fire Girls.* These Title IX regulations do not apply to the membership practices of the Young Men's Christian Association (YMCA), the Young Women's Christian Association (YWCA), the Girl Scouts, the Boy Scouts, and Camp Fire Girls.

(c) *Voluntary youth service organizations.* These Title IX regulations do not apply to the membership practices of a voluntary youth service organization that is exempt from taxation under section 501(a) of the Internal Revenue Code of 1954, 26 U.S.C. 501(a), and the membership of which has been traditionally limited to members of one sex and principally to persons of less than nineteen years of age.

#### § 1211.220 Admissions.

(a) Admissions to educational institutions prior to June 24, 1973, are not covered by these Title IX regulations.

(b) *Administratively separate units.* For the purposes only of this section,

## § 1211.225

§§ 1211.225 and 1211.230, and §§ 1211.300 through 1211.310, each administratively separate unit shall be deemed to be an educational institution.

(c) *Application of §§ 1211.300 through 1211.310.* Except as provided in paragraphs (d) and (e) of this section, §§ 1211.300 through 1211.310 apply to each recipient. A recipient to which §§ 1211.300 through 1211.310 apply shall not discriminate on the basis of sex in admission or recruitment in violation of §§ 1211.300 through 1211.310.

(d) *Educational institutions.* Except as provided in paragraph (e) of this section as to recipients that are educational institutions, §§ 1211.300 through 1211.310 apply only to institutions of vocational education, professional education, graduate higher education, and public institutions of undergraduate higher education.

(e) *Public institutions of undergraduate higher education.* §§ 1211.300 through 1211.310 do not apply to any public institution of undergraduate higher education that traditionally and continually from its establishment has had a policy of admitting students of only one sex.

### § 1211.225 Educational institutions eligible to submit transition plans.

(a) *Application.* This section applies to each educational institution to which §§ 1211.300 through 1211.310 apply that:

(1) Admitted students of only one sex as regular students as of June 23, 1972; or

(2) Admitted students of only one sex as regular students as of June 23, 1965, but thereafter admitted, as regular students, students of the sex not admitted prior to June 23, 1965.

(b) *Provision for transition plans.* An educational institution to which this section applies shall not discriminate on the basis of sex in admission or recruitment in violation of §§ 1211.300 through 1211.310.

### § 1211.230 Transition plans.

(a) *Submission of plans.* An institution to which § 1211.225 applies and that is composed of more than one administratively separate unit may submit either a single transition plan applicable to

## 36 CFR Ch. XII (7-1-03 Edition)

all such units, or a separate transition plan applicable to each such unit.

(b) *Content of plans.* In order to be approved by the Secretary of Education, a transition plan shall:

(1) State the name, address, and Federal Interagency Committee on Education Code of the educational institution submitting such plan, the administratively separate units to which the plan is applicable, and the name, address, and telephone number of the person to whom questions concerning the plan may be addressed. The person who submits the plan shall be the chief administrator or president of the institution, or another individual legally authorized to bind the institution to all actions set forth in the plan.

(2) State whether the educational institution or administratively separate unit admits students of both sexes as regular students and, if so, when it began to do so.

(3) Identify and describe with respect to the educational institution or administratively separate unit any obstacles to admitting students without discrimination on the basis of sex.

(4) Describe in detail the steps necessary to eliminate as soon as practicable each obstacle so identified and indicate the schedule for taking these steps and the individual directly responsible for their implementation.

(5) Include estimates of the number of students, by sex, expected to apply for, be admitted to, and enter each class during the period covered by the plan.

(c) *Nondiscrimination.* No policy or practice of a recipient to which § 1211.225 applies shall result in treatment of applicants to or students of such recipient in violation of §§ 1211.300 through 1211.310 unless such treatment is necessitated by an obstacle identified in paragraph (b)(3) of this section and a schedule for eliminating that obstacle has been provided as required by paragraph (b)(4) of this section.

(d) *Effects of past exclusion.* To overcome the effects of past exclusion of students on the basis of sex, each educational institution to which § 1211.225 applies shall include in its transition plan, and shall implement, specific steps designed to encourage individuals of the previously excluded sex to apply

for admission to such institution. Such steps shall include instituting recruitment programs that emphasize the institution's commitment to enrolling students of the sex previously excluded.

**§ 1211.235 Statutory amendments.**

(a) This section, which applies to all provisions of these Title IX regulations, addresses statutory amendments to Title IX.

(b) These Title IX regulations shall not apply to or preclude:

(1) Any program or activity of the American Legion undertaken in connection with the organization or operation of any Boys State conference, Boys Nation conference, Girls State conference, or Girls Nation conference;

(2) Any program or activity of a secondary school or educational institution specifically for:

(i) The promotion of any Boys State conference, Boys Nation conference, Girls State conference, or Girls Nation conference; or

(ii) The selection of students to attend any such conference;

(3) Father-son or mother-daughter activities at an educational institution or in an education program or activity, but if such activities are provided for students of one sex, opportunities for reasonably comparable activities shall be provided to students of the other sex;

(4) Any scholarship or other financial assistance awarded by an institution of higher education to an individual because such individual has received such award in a single-sex pageant based upon a combination of factors related to the individual's personal appearance, poise, and talent. The pageant, however, must comply with other non-discrimination provisions of Federal law.

(c) *Program or activity or program* means:

(1) All of the operations of any entity described in paragraphs (c)(1)(i) through (iv) of this section, any part of which is extended Federal financial assistance:

(i)(A) A department, agency, special purpose district, or other instrumentality of a State or of a local government; or

(B) The entity of such State or local government that distributes such assistance and each such department or agency (and each other State or local government entity) to which the assistance is extended, in the case of assistance to a State or local government;

(ii)(A) A college, university, or other postsecondary institution, or a public system of higher education; or

(B) A local educational agency (as defined in section 8801 of title 20), system of vocational education, or other school system;

(iii)(A) An entire corporation, partnership, or other private organization, or an entire sole proprietorship—

(1) If assistance is extended to such corporation, partnership, private organization, or sole proprietorship as a whole; or

(2) Which is principally engaged in the business of providing education, health care, housing, social services, or parks and recreation; or

(B) The entire plant or other comparable, geographically separate facility to which Federal financial assistance is extended, in the case of any other corporation, partnership, private organization, or sole proprietorship; or

(iv) Any other entity that is established by two or more of the entities described in paragraphs (c)(1)(i), (ii), or (iii) of this section.

(2)(i) *Program or activity* does not include any operation of an entity that is controlled by a religious organization if the application of 20 U.S.C. 1681 to such operation would not be consistent with the religious tenets of such organization.

(ii) For example, all of the operations of a college, university, or other postsecondary institution, including but not limited to traditional educational operations, faculty and student housing, campus shuttle bus service, campus restaurants, the bookstore, and other commercial activities are part of a "program or activity" subject to these Title IX regulations if the college, university, or other institution receives Federal financial assistance.

(d)(1) Nothing in these Title IX regulations shall be construed to require or prohibit any person, or public or private entity, to provide or pay for any

§ 1211.300

benefit or service, including the use of facilities, related to an abortion. Medical procedures, benefits, services, and the use of facilities, necessary to save the life of a pregnant woman or to address complications related to an abortion are not subject to this section.

(2) Nothing in this section shall be construed to permit a penalty to be imposed on any person or individual because such person or individual is seeking or has received any benefit or service related to a legal abortion. Accordingly, subject to paragraph (d)(1) of this section, no person shall be excluded from participation in, be denied the benefits of, or be subjected to discrimination under any academic, extracurricular, research, occupational training, employment, or other educational program or activity operated by a recipient that receives Federal financial assistance because such individual has sought or received, or is seeking, a legal abortion, or any benefit or service related to a legal abortion.

**Subpart C—Discrimination on the Basis of Sex in Admission and Recruitment Prohibited**

**§ 1211.300 Admission.**

(a) *General.* No person shall, on the basis of sex, be denied admission, or be subjected to discrimination in admission, by any recipient to which §§1211.300 through §§1211.310 apply, except as provided in §1211.225 and §1211.230.

(b) *Specific prohibitions.* (1) In determining whether a person satisfies any policy or criterion for admission, or in making any offer of admission, a recipient to which §§1211.300 through 1211.310 apply shall not:

- (i) Give preference to one person over another on the basis of sex, by ranking applicants separately on such basis, or otherwise;
- (ii) Apply numerical limitations upon the number or proportion of persons of either sex who may be admitted; or
- (iii) Otherwise treat one individual differently from another on the basis of sex.

(2) A recipient shall not administer or operate any test or other criterion for admission that has a disproportion-

ately adverse effect on persons on the basis of sex unless the use of such test or criterion is shown to predict validly success in the education program or activity in question and alternative tests or criteria that do not have such a disproportionately adverse effect are shown to be unavailable.

(c) *Prohibitions relating to marital or parental status.* In determining whether a person satisfies any policy or criterion for admission, or in making any offer of admission, a recipient to which §§1211.300 through 1211.310 apply:

(1) Shall not apply any rule concerning the actual or potential parental, family, or marital status of a student or applicant that treats persons differently on the basis of sex;

(2) Shall not discriminate against or exclude any person on the basis of pregnancy, childbirth, termination of pregnancy, or recovery therefrom, or establish or follow any rule or practice that so discriminates or excludes;

(3) Subject to §1211.235(d), shall treat disabilities related to pregnancy, childbirth, termination of pregnancy, or recovery therefrom in the same manner and under the same policies as any other temporary disability or physical condition; and

(4) Shall not make pre-admission inquiry as to the marital status of an applicant for admission, including whether such applicant is "Miss" or "Mrs." A recipient may make pre-admission inquiry as to the sex of an applicant for admission, but only if such inquiry is made equally of such applicants of both sexes and if the results of such inquiry are not used in connection with discrimination prohibited by these Title IX regulations.

**§ 1211.305 Preference in admission.**

A recipient to which §§1211.300 through 1211.310 apply shall not give preference to applicants for admission, on the basis of attendance at any educational institution or other school or entity that admits as students only or predominantly members of one sex, if the giving of such preference has the effect of discriminating on the basis of sex in violation of §§1211.300 through 1211.310.



**§ 1211.310 Recruitment.**

(a) *Nondiscriminatory recruitment.* A recipient to which §§ 1211.300 through 1211.310 apply shall not discriminate on the basis of sex in the recruitment and admission of students. A recipient may be required to undertake additional recruitment efforts for one sex as remedial action pursuant to § 1211.110(a), and may choose to undertake such efforts as affirmative action pursuant to § 1211.110(b).

(b) *Recruitment at certain institutions.* A recipient to which §§ 1211.300 through 1211.310 apply shall not recruit primarily or exclusively at educational institutions, schools, or entities that admit as students only or predominantly members of one sex, if such actions have the effect of discriminating on the basis of sex in violation of §§ 1211.300 through 1211.310.

### Subpart D—Discrimination on the Basis of Sex in Education Programs or Activities Prohibited

**§ 1211.400 Education programs or activities.**

(a) *General.* Except as provided elsewhere in these Title IX regulations, no person shall, on the basis of sex, be excluded from participation in, be denied the benefits of, or be subjected to discrimination under any academic, extracurricular, research, occupational training, or other education program or activity operated by a recipient that receives Federal financial assistance. Sections 1211.400 through 1211.455 do not apply to actions of a recipient in connection with admission of its students to an education program or activity of a recipient to which §§ 1211.300 through 1211.310 do not apply, or an entity, not a recipient, to which §§ 1211.300 through 1211.310 would not apply if the entity were a recipient.

(b) *Specific prohibitions.* Except as provided in §§ 1211.400 through 1211.455, in providing any aid, benefit, or service to a student, a recipient shall not, on the basis of sex:

(1) Treat one person differently from another in determining whether such person satisfies any requirement or condition for the provision of such aid, benefit, or service;

(2) Provide different aid, benefits, or services or provide aid, benefits, or services in a different manner;

(3) Deny any person any such aid, benefit, or service;

(4) Subject any person to separate or different rules of behavior, sanctions, or other treatment;

(5) Apply any rule concerning the domicile or residence of a student or applicant, including eligibility for in-state fees and tuition;

(6) Aid or perpetuate discrimination against any person by providing significant assistance to any agency, organization, or person that discriminates on the basis of sex in providing any aid, benefit, or service to students or employees;

(7) Otherwise limit any person in the enjoyment of any right, privilege, advantage, or opportunity.

(c) *Assistance administered by a recipient educational institution to study at a foreign institution.* A recipient educational institution may administer or assist in the administration of scholarships, fellowships, or other awards established by foreign or domestic wills, trusts, or similar legal instruments, or by acts of foreign governments and restricted to members of one sex, that are designed to provide opportunities to study abroad, and that are awarded to students who are already matriculating at or who are graduates of the recipient institution; *Provided*, that a recipient educational institution that administers or assists in the administration of such scholarships, fellowships, or other awards that are restricted to members of one sex provides, or otherwise makes available, reasonable opportunities for similar studies for members of the other sex. Such opportunities may be derived from either domestic or foreign sources.

(d) *Aids, benefits or services not provided by recipient.* (1) This paragraph (d) applies to any recipient that requires participation by any applicant, student, or employee in any education program or activity not operated wholly by such recipient, or that facilitates, permits, or considers such participation as part of or equivalent to an education program or activity operated by such recipient, including participation

**§ 1211.405**

in educational consortia and cooperative employment and student-teaching assignments.

(2) Such recipient:

(i) Shall develop and implement a procedure designed to assure itself that the operator or sponsor of such other education program or activity takes no action affecting any applicant, student, or employee of such recipient that these Title IX regulations would prohibit such recipient from taking; and

(ii) Shall not facilitate, require, permit, or consider such participation if such action occurs.

**§ 1211.405 Housing.**

(a) *Generally.* A recipient shall not, on the basis of sex, apply different rules or regulations, impose different fees or requirements, or offer different services or benefits related to housing, except as provided in this section (including housing provided only to married students).

(b) *Housing provided by recipient.* (1) A recipient may provide separate housing on the basis of sex.

(2) Housing provided by a recipient to students of one sex, when compared to that provided to students of the other sex, shall be as a whole:

(i) Proportionate in quantity to the number of students of that sex applying for such housing; and

(ii) Comparable in quality and cost to the student.

(c) *Other housing.* (1) A recipient shall not, on the basis of sex, administer different policies or practices concerning occupancy by its students of housing other than that provided by such recipient.

(2)(i) A recipient which, through solicitation, listing, approval of housing, or otherwise, assists any agency, organization, or person in making housing available to any of its students, shall take such reasonable action as may be necessary to assure itself that such housing as is provided to students of one sex, when compared to that provided to students of the other sex, is as a whole:

(A) Proportionate in quantity; and

(B) Comparable in quality and cost to the student.

(ii) A recipient may render such assistance to any agency, organization,

**36 CFR Ch. XII (7-1-03 Edition)**

or person that provides all or part of such housing to students of only one sex.

**§ 1211.410 Comparable facilities.**

A recipient may provide separate toilet, locker room, and shower facilities on the basis of sex, but such facilities provided for students of one sex shall be comparable to such facilities provided for students of the other sex.

**§ 1211.415 Access to course offerings.**

(a) A recipient shall not provide any course or otherwise carry out any of its education program or activity separately on the basis of sex, or require or refuse participation therein by any of its students on such basis, including health, physical education, industrial, business, vocational, technical, home economics, music, and adult education courses.

(b)(1) With respect to classes and activities in physical education at the elementary school level, the recipient shall comply fully with this section as expeditiously as possible but in no event later than one year from September 29, 2000. With respect to physical education classes and activities at the secondary and post-secondary levels, the recipient shall comply fully with this section as expeditiously as possible but in no event later than three years from September 29, 2000.

(2) This section does not prohibit grouping of students in physical education classes and activities by ability as assessed by objective standards of individual performance developed and applied without regard to sex.

(3) This section does not prohibit separation of students by sex within physical education classes or activities during participation in wrestling, boxing, rugby, ice hockey, football, basketball, and other sports the purpose or major activity of which involves bodily contact.

(4) Where use of a single standard of measuring skill or progress in a physical education class has an adverse effect on members of one sex, the recipient shall use appropriate standards that do not have such effect.

(5) Portions of classes in elementary and secondary schools, or portions of education programs or activities, that

deal exclusively with human sexuality may be conducted in separate sessions for boys and girls.

(6) Recipients may make requirements based on vocal range or quality that may result in a chorus or choruses of one or predominantly one sex.

**§ 1211.420 Access to schools operated by LEAs.**

A recipient that is a local educational agency shall not, on the basis of sex, exclude any person from admission to:

(a) Any institution of vocational education operated by such recipient; or

(b) Any other school or educational unit operated by such recipient, unless such recipient otherwise makes available to such person, pursuant to the same policies and criteria of admission, courses, services, and facilities comparable to each course, service, and facility offered in or through such schools.

**§ 1211.425 Counseling and use of appraisal and counseling materials.**

(a) *Counseling.* A recipient shall not discriminate against any person on the basis of sex in the counseling or guidance of students or applicants for admission.

(b) *Use of appraisal and counseling materials.* A recipient that uses testing or other materials for appraising or counseling students shall not use different materials for students on the basis of their sex or use materials that permit or require different treatment of students on such basis unless such different materials cover the same occupations and interest areas and the use of such different materials is shown to be essential to eliminate sex bias. Recipients shall develop and use internal procedures for ensuring that such materials do not discriminate on the basis of sex. Where the use of a counseling test or other instrument results in a substantially disproportionate number of members of one sex in any particular course of study or classification, the recipient shall take such action as is necessary to assure itself that such disproportion is not the result of discrimination in the instrument or its application.

(c) *Disproportion in classes.* Where a recipient finds that a particular class contains a substantially disproportionate number of individuals of one sex, the recipient shall take such action as is necessary to assure itself that such disproportion is not the result of discrimination on the basis of sex in counseling or appraisal materials or by counselors.

**§ 1211.430 Financial assistance.**

(a) *General.* Except as provided in paragraphs (b) and (c) of this section, in providing financial assistance to any of its students, a recipient shall not:

(1) On the basis of sex, provide different amounts or types of such assistance, limit eligibility for such assistance that is of any particular type or source, apply different criteria, or otherwise discriminate;

(2) Through solicitation, listing, approval, provision of facilities, or other services, assist any foundation, trust, agency, organization, or person that provides assistance to any of such recipient's students in a manner that discriminates on the basis of sex; or

(3) Apply any rule or assist in application of any rule concerning eligibility for such assistance that treats persons of one sex differently from persons of the other sex with regard to marital or parental status.

(b) *Financial aid established by certain legal instruments.* (1) A recipient may administer or assist in the administration of scholarships, fellowships, or other forms of financial assistance established pursuant to domestic or foreign wills, trusts, bequests, or similar legal instruments or by acts of a foreign government that require that awards be made to members of a particular sex specified therein; *Provided*, that the overall effect of the award of such sex-restricted scholarships, fellowships, and other forms of financial assistance does not discriminate on the basis of sex.

(2) To ensure nondiscriminatory awards of assistance as required in paragraph (b)(1) of this section, recipients shall develop and use procedures under which:

(i) Students are selected for award of financial assistance on the basis of nondiscriminatory criteria and not on

**§ 1211.435**

the basis of availability of funds restricted to members of a particular sex;

(ii) An appropriate sex-restricted scholarship, fellowship, or other form of financial assistance is allocated to each student selected under paragraph (b)(2)(i) of this section; and

(iii) No student is denied the award for which he or she was selected under paragraph (b)(2)(i) of this section because of the absence of a scholarship, fellowship, or other form of financial assistance designated for a member of that student's sex.

(c) *Athletic scholarships.* (1) To the extent that a recipient awards athletic scholarships or grants-in-aid, it must provide reasonable opportunities for such awards for members of each sex in proportion to the number of students of each sex participating in interscholastic or intercollegiate athletics.

(2) A recipient may provide separate athletic scholarships or grants-in-aid for members of each sex as part of separate athletic teams for members of each sex to the extent consistent with this paragraph (c) and § 1211.450.

**§ 1211.435 Employment assistance to students.**

(a) *Assistance by recipient in making available outside employment.* A recipient that assists any agency, organization, or person in making employment available to any of its students:

(1) Shall assure itself that such employment is made available without discrimination on the basis of sex; and

(2) Shall not render such services to any agency, organization, or person that discriminates on the basis of sex in its employment practices.

(b) *Employment of students by recipients.* A recipient that employs any of its students shall not do so in a manner that violates §§ 1211.500 through 1211.550.

**§ 1211.440 Health and insurance benefits and services.**

Subject to § 1211.235(d), in providing a medical, hospital, accident, or life insurance benefit, service, policy, or plan to any of its students, a recipient shall not discriminate on the basis of sex, or provide such benefit, service, policy, or plan in a manner that would violate §§ 1211.500 through 1211.550 if it were

**36 CFR Ch. XII (7-1-03 Edition)**

provided to employees of the recipient. This section shall not prohibit a recipient from providing any benefit or service that may be used by a different proportion of students of one sex than of the other, including family planning services. However, any recipient that provides full coverage health service shall provide gynecological care.

**§ 1211.445 Marital or parental status.**

(a) *Status generally.* A recipient shall not apply any rule concerning a student's actual or potential parental, family, or marital status that treats students differently on the basis of sex.

(b) *Pregnancy and related conditions.*

(1) A recipient shall not discriminate against any student, or exclude any student from its education program or activity, including any class or extracurricular activity, on the basis of such student's pregnancy, childbirth, false pregnancy, termination of pregnancy, or recovery therefrom, unless the student requests voluntarily to participate in a separate portion of the program or activity of the recipient.

(2) A recipient may require such a student to obtain the certification of a physician that the student is physically and emotionally able to continue participation as long as such a certification is required of all students for other physical or emotional conditions requiring the attention of a physician.

(3) A recipient that operates a portion of its education program or activity separately for pregnant students, admittance to which is completely voluntary on the part of the student as provided in paragraph (b)(1) of this section, shall ensure that the separate portion is comparable to that offered to non-pregnant students.

(4) Subject to § 1211.235(d), a recipient shall treat pregnancy, childbirth, false pregnancy, termination of pregnancy and recovery therefrom in the same manner and under the same policies as any other temporary disability with respect to any medical or hospital benefit, service, plan, or policy that such recipient administers, operates, offers, or participates in with respect to students admitted to the recipient's educational program or activity.

(5) In the case of a recipient that does not maintain a leave policy for its students, or in the case of a student who does not otherwise qualify for leave under such a policy, a recipient shall treat pregnancy, childbirth, false pregnancy, termination of pregnancy, and recovery therefrom as a justification for a leave of absence for as long a period of time as is deemed medically necessary by the student's physician, at the conclusion of which the student shall be reinstated to the status that she held when the leave began.

**§ 1211.450 Athletics.**

(a) *General.* No person shall, on the basis of sex, be excluded from participation in, be denied the benefits of, be treated differently from another person, or otherwise be discriminated against in any interscholastic, intercollegiate, club, or intramural athletics offered by a recipient, and no recipient shall provide any such athletics separately on such basis.

(b) *Separate teams.* Notwithstanding the requirements of paragraph (a) of this section, a recipient may operate or sponsor separate teams for members of each sex where selection for such teams is based upon competitive skill or the activity involved is a contact sport. However, where a recipient operates or sponsors a team in a particular sport for members of one sex but operates or sponsors no such team for members of the other sex, and athletic opportunities for members of that sex have previously been limited, members of the excluded sex must be allowed to try out for the team offered unless the sport involved is a contact sport. For the purposes of these Title IX regulations, contact sports include boxing, wrestling, rugby, ice hockey, football, basketball, and other sports the purpose or major activity of which involves bodily contact.

(c) *Equal opportunity.* (1) A recipient that operates or sponsors interscholastic, intercollegiate, club, or intramural athletics shall provide equal athletic opportunity for members of both sexes. In determining whether equal opportunities are available, the designated agency official will consider, among other factors:

(i) Whether the selection of sports and levels of competition effectively accommodate the interests and abilities of members of both sexes;

(ii) The provision of equipment and supplies;

(iii) Scheduling of games and practice time;

(iv) Travel and per diem allowance;

(v) Opportunity to receive coaching and academic tutoring;

(vi) Assignment and compensation of coaches and tutors;

(vii) Provision of locker rooms, practice, and competitive facilities;

(viii) Provision of medical and training facilities and services;

(ix) Provision of housing and dining facilities and services;

(x) Publicity.

(2) For purposes of paragraph (c)(1) of this section, unequal aggregate expenditures for members of each sex or unequal expenditures for male and female teams if a recipient operates or sponsors separate teams will not constitute noncompliance with this section, but the designated agency official may consider the failure to provide necessary funds for teams for one sex in assessing equality of opportunity for members of each sex.

(d) *Adjustment period.* A recipient that operates or sponsors interscholastic, intercollegiate, club, or intramural athletics at the elementary school level shall comply fully with this section as expeditiously as possible but in no event later than one year from September 29, 2000. A recipient that operates or sponsors interscholastic, intercollegiate, club, or intramural athletics at the secondary or postsecondary school level shall comply fully with this section as expeditiously as possible but in no event later than three years from September 29, 2000.

**§ 1211.455 Textbooks and curricular material.**

Nothing in these Title IX regulations shall be interpreted as requiring or prohibiting or abridging in any way the use of particular textbooks or curricular materials.

**Subpart E—Discrimination on the Basis of Sex in Employment in Education Programs or Activities Prohibited**

**§ 1211.500 Employment.**

(a) *General.* (1) No person shall, on the basis of sex, be excluded from participation in, be denied the benefits of, or be subjected to discrimination in employment, or recruitment, consideration, or selection therefor, whether full-time or part-time, under any education program or activity operated by a recipient that receives Federal financial assistance.

(2) A recipient shall make all employment decisions in any education program or activity operated by such recipient in a nondiscriminatory manner and shall not limit, segregate, or classify applicants or employees in any way that could adversely affect any applicant's or employee's employment opportunities or status because of sex.

(3) A recipient shall not enter into any contractual or other relationship which directly or indirectly has the effect of subjecting employees or students to discrimination prohibited by §§ 1211.500 through 1211.550, including relationships with employment and referral agencies, with labor unions, and with organizations providing or administering fringe benefits to employees of the recipient.

(4) A recipient shall not grant preferences to applicants for employment on the basis of attendance at any educational institution or entity that admits as students only or predominantly members of one sex, if the giving of such preferences has the effect of discriminating on the basis of sex in violation of these Title IX regulations.

(b) *Application.* The provisions of §§ 1211.500 through 1211.550 apply to:

(1) Recruitment, advertising, and the process of application for employment;

(2) Hiring, upgrading, promotion, consideration for and award of tenure, demotion, transfer, layoff, termination, application of nepotism policies, right of return from layoff, and rehiring;

(3) Rates of pay or any other form of compensation, and changes in compensation;

(4) Job assignments, classifications, and structure, including position descriptions, lines of progression, and seniority lists;

(5) The terms of any collective bargaining agreement;

(6) Granting and return from leaves of absence, leave for pregnancy, childbirth, false pregnancy, termination of pregnancy, leave for persons of either sex to care for children or dependents, or any other leave;

(7) Fringe benefits available by virtue of employment, whether or not administered by the recipient;

(8) Selection and financial support for training, including apprenticeship, professional meetings, conferences, and other related activities, selection for tuition assistance, selection for sabbaticals and leaves of absence to pursue training;

(9) Employer-sponsored activities, including social or recreational programs; and

(10) Any other term, condition, or privilege of employment.

**§ 1211.505 Employment criteria.**

A recipient shall not administer or operate any test or other criterion for any employment opportunity that has a disproportionately adverse effect on persons on the basis of sex unless:

(a) Use of such test or other criterion is shown to predict validly successful performance in the position in question; and

(b) Alternative tests or criteria for such purpose, which do not have such disproportionately adverse effect, are shown to be unavailable.

**§ 1211.510 Recruitment.**

(a) *Nondiscriminatory recruitment and hiring.* A recipient shall not discriminate on the basis of sex in the recruitment and hiring of employees. Where a recipient has been found to be presently discriminating on the basis of sex in the recruitment or hiring of employees, or has been found to have so discriminated in the past, the recipient shall recruit members of the sex so discriminated against so as to overcome the effects of such past or present discrimination.

(b) *Recruitment patterns.* A recipient shall not recruit primarily or exclusively at entities that furnish as applicants only or predominantly members of one sex if such actions have the effect of discriminating on the basis of sex in violation of §§ 1211.500 through 1211.550.

**§ 1211.515 Compensation.**

A recipient shall not make or enforce any policy or practice that, on the basis of sex:

(a) Makes distinctions in rates of pay or other compensation;

(b) Results in the payment of wages to employees of one sex at a rate less than that paid to employees of the opposite sex for equal work on jobs the performance of which requires equal skill, effort, and responsibility, and that are performed under similar working conditions.

**§ 1211.520 Job classification and structure.**

A recipient shall not:

(a) Classify a job as being for males or for females;

(b) Maintain or establish separate lines of progression, seniority lists, career ladders, or tenure systems based on sex; or

(c) Maintain or establish separate lines of progression, seniority systems, career ladders, or tenure systems for similar jobs, position descriptions, or job requirements that classify persons on the basis of sex, unless sex is a bona fide occupational qualification for the positions in question as set forth in § 1211.550.

**§ 1211.525 Fringe benefits.**

(a) *“Fringe benefits” defined.* For purposes of these Title IX regulations, *fringe benefits* means: Any medical, hospital, accident, life insurance, or retirement benefit, service, policy or plan, any profit-sharing or bonus plan, leave, and any other benefit or service of employment not subject to the provision of § 1211.515.

(b) *Prohibitions.* A recipient shall not:

(1) Discriminate on the basis of sex with regard to making fringe benefits available to employees or make fringe benefits available to spouses, families,

or dependents of employees differently upon the basis of the employee’s sex;

(2) Administer, operate, offer, or participate in a fringe benefit plan that does not provide for equal periodic benefits for members of each sex and for equal contributions to the plan by such recipient for members of each sex; or

(3) Administer, operate, offer, or participate in a pension or retirement plan that establishes different optional or compulsory retirement ages based on sex or that otherwise discriminates in benefits on the basis of sex.

**§ 1211.530 Marital or parental status.**

(a) *General.* A recipient shall not apply any policy or take any employment action:

(1) Concerning the potential marital, parental, or family status of an employee or applicant for employment that treats persons differently on the basis of sex; or

(2) Which is based upon whether an employee or applicant for employment is the head of household or principal wage earner in such employee’s or applicant’s family unit.

(b) *Pregnancy.* A recipient shall not discriminate against or exclude from employment any employee or applicant for employment on the basis of pregnancy, childbirth, false pregnancy, termination of pregnancy, or recovery therefrom.

(c) *Pregnancy as a temporary disability.* Subject to § 1211.235(d), a recipient shall treat pregnancy, childbirth, false pregnancy, termination of pregnancy, recovery therefrom, and any temporary disability resulting therefrom as any other temporary disability for all job-related purposes, including commencement, duration, and extensions of leave, payment of disability income, accrual of seniority and any other benefit or service, and reinstatement, and under any fringe benefit offered to employees by virtue of employment.

(d) *Pregnancy leave.* In the case of a recipient that does not maintain a leave policy for its employees, or in the case of an employee with insufficient leave or accrued employment time to qualify for leave under such a policy, a recipient shall treat pregnancy, childbirth, false pregnancy, termination of pregnancy, and recovery therefrom as a

### § 1211.535

justification for a leave of absence without pay for a reasonable period of time, at the conclusion of which the employee shall be reinstated to the status that she held when the leave began or to a comparable position, without decrease in rate of compensation or loss of promotional opportunities, or any other right or privilege of employment.

#### § 1211.535 Effect of state or local law or other requirements.

(a) *Prohibitory requirements.* The obligation to comply with §§1211.500 through 1211.550 is not obviated or alleviated by the existence of any State or local law or other requirement that imposes prohibitions or limits upon employment of members of one sex that are not imposed upon members of the other sex.

(b) *Benefits.* A recipient that provides any compensation, service, or benefit to members of one sex pursuant to a State or local law or other requirement shall provide the same compensation, service, or benefit to members of the other sex.

#### § 1211.540 Advertising.

A recipient shall not in any advertising related to employment indicate preference, limitation, specification, or discrimination based on sex unless sex is a bona fide occupational qualification for the particular job in question.

#### § 1211.545 Pre-employment inquiries.

(a) *Marital status.* A recipient shall not make pre-employment inquiry as to the marital status of an applicant for employment, including whether such applicant is "Miss" or "Mrs."

(b) *Sex.* A recipient may make pre-employment inquiry as to the sex of an applicant for employment, but only if such inquiry is made equally of such applicants of both sexes and if the results of such inquiry are not used in connection with discrimination prohibited by these Title IX regulations.

#### § 1211.550 Sex as a bona fide occupational qualification.

A recipient may take action otherwise prohibited by §§1211.500 through 1211.550 provided it is shown that sex is a bona fide occupational qualification

### 36 CFR Ch. XII (7-1-03 Edition)

for that action, such that consideration of sex with regard to such action is essential to successful operation of the employment function concerned. A recipient shall not take action pursuant to this section that is based upon alleged comparative employment characteristics or stereotyped characterizations of one or the other sex, or upon preference based on sex of the recipient, employees, students, or other persons, but nothing contained in this section shall prevent a recipient from considering an employee's sex in relation to employment in a locker room or toilet facility used only by members of one sex.

## Subpart F—Procedures

#### § 1211.600 Notice of covered programs.

Within 60 days of September 29, 2000, each Federal agency that awards Federal financial assistance shall publish in the FEDERAL REGISTER a notice of the programs covered by these Title IX regulations. Each such Federal agency shall periodically republish the notice of covered programs to reflect changes in covered programs. Copies of this notice also shall be made available upon request to the Federal agency's office that enforces Title IX.

#### § 1211.605 Compliance information.

(a) *Cooperation and assistance.* The designated agency official shall to the fullest extent practicable seek the cooperation of recipients in obtaining compliance with these Title IX regulations and shall provide assistance and guidance to recipients to help them comply voluntarily with these Title IX regulations.

(b) *Compliance reports.* Each recipient shall keep such records and submit to the designated agency official (or designee) timely, complete, and accurate compliance reports at such times, and in such form and containing such information, as the designated agency official (or designee) may determine to be necessary to enable the official to ascertain whether the recipient has complied or is complying with these Title IX regulations. In the case of any program under which a primary recipient extends Federal financial assistance to



any other recipient, such other recipient shall also submit such compliance reports to the primary recipient as may be necessary to enable the primary recipient to carry out its obligations under these Title IX regulations.

(c) *Access to sources of information.* Each recipient shall permit access by the designated agency official (or designee) during normal business hours to such of its books, records, accounts, and other sources of information, and its facilities as may be pertinent to ascertain compliance with these Title IX regulations. Where any information required of a recipient is in the exclusive possession of any other agency, institution, or person and this agency, institution, or person shall fail or refuse to furnish this information the recipient shall so certify in its report and shall set forth what efforts it has made to obtain the information. Asserted considerations of privacy or confidentiality may not operate to bar the agency from evaluating or seeking to enforce compliance with these Title IX regulations. Information of a confidential nature obtained in connection with compliance evaluation or enforcement shall not be disclosed except where necessary in formal enforcement proceedings or where otherwise required by law.

(d) *Information to beneficiaries and participants.* Each recipient shall make available to participants, beneficiaries, and other interested persons such information regarding the provisions of these Title IX regulations and their applicability to the program for which the recipient receives Federal financial assistance, and make such information available to them in such manner, as the designated agency official finds necessary to apprise such persons of the protections against discrimination assured them by Title IX and these Title IX regulations.

[65 FR 52886, Aug. 30, 2000]

**§ 1211.610 Conduct of investigations.**

(a) *Periodic compliance reviews.* The designated agency official (or designee) shall from time to time review the practices of recipients to determine whether they are complying with these Title IX regulations.

(b) *Complaints.* Any person who believes himself or herself or any specific class of individuals to be subjected to discrimination prohibited by these Title IX regulations may by himself or herself or by a representative file with the designated agency official (or designee) a written complaint. A complaint must be filed not later than 180 days from the date of the alleged discrimination, unless the time for filing is extended by the designated agency official (or designee).

(c) *Investigations.* The designated agency official (or designee) will make a prompt investigation whenever a compliance review, report, complaint, or any other information indicates a possible failure to comply with these Title IX regulations. The investigation should include, where appropriate, a review of the pertinent practices and policies of the recipient, the circumstances under which the possible noncompliance with these Title IX regulations occurred, and other factors relevant to a determination as to whether the recipient has failed to comply with these Title IX regulations.

(d) *Resolution of matters.* (1) If an investigation pursuant to paragraph (c) of this section indicates a failure to comply with these Title IX regulations, the designated agency official (or designee) will so inform the recipient and the matter will be resolved by informal means whenever possible. If it has been determined that the matter cannot be resolved by informal means, action will be taken as provided for in § 1211.615.

(2) If an investigation does not warrant action pursuant to paragraph (d) (1) of this section the designated agency official (or designee) will so inform the recipient and the complainant, if any, in writing.

(e) *Intimidatory or retaliatory acts prohibited.* No recipient or other person shall intimidate, threaten, coerce, or discriminate against any individual for the purpose of interfering with any right or privilege secured by Title IX or these Title IX regulations, or because he or she has made a complaint, testified, assisted, or participated in any manner in an investigation, proceeding, or hearing under these Title

§ 1211.615

36 CFR Ch. XII (7-1-03 Edition)

IX regulations. The identity of complainants shall be kept confidential except to the extent necessary to carry out the purposes of these Title IX regulations, including the conduct of any investigation, hearing, or judicial proceeding arising under these Title IX regulations.

[65 FR 52887, Aug. 30, 2000]

§ 1211.615 Procedure for effecting compliance.

(a) General. If there appears to be a failure or threatened failure to comply with these Title IX regulations, and if the noncompliance or threatened non-compliance cannot be corrected by informal means, compliance with these Title IX regulations may be effected by the suspension or termination of or refusal to grant or to continue Federal financial assistance or by any other means authorized by law. Such other means may include, but are not limited to:

(1) A reference to the Department of Justice with a recommendation that appropriate proceedings be brought to enforce any rights of the United States under any law of the United States, or any assurance or other contractual undertaking; and

(2) Any applicable proceeding under State or local law.

(b) Noncompliance with § 1211.115. If an applicant fails or refuses to furnish an assurance or otherwise fails or refuses to comply with a requirement imposed by or pursuant to § 1211.115, Federal financial assistance may be refused in accordance with the procedures of paragraph (c) of this section. The agency shall not be required to provide assistance in such a case during the pendency of the administrative proceedings under paragraph (c) of this section except that the agency shall continue assistance during the pendency of such proceedings where such assistance is due and payable pursuant to an application therefor approved prior to September 29, 2000.

(c) Termination of or refusal to grant or to continue Federal financial assistance.

(1) No order suspending, terminating, or refusing to grant or continue Federal financial assistance shall become effective until:

(i) The designated agency official has advised the applicant or recipient of its failure to comply and has determined that compliance cannot be secured by voluntary means;

(ii) There has been an express finding on the record, after opportunity for hearing, of a failure by the applicant or recipient to comply with a requirement imposed by or pursuant to these Title IX regulations; and

(iii) The expiration of 30 days after the Archivist has filed with the committee of the House, and the committee of the Senate having legislative jurisdiction over the program involved, a full written report of the circumstances and the grounds for such action.

(2) Any action to suspend or terminate or to refuse to grant or to continue Federal financial assistance shall be limited to the particular political entity, or part thereof, or other applicant or recipient as to whom such a finding has been made and shall be limited in its effect to the particular program, or part thereof, in which such noncompliance has been so found.

(d) Other means authorized by law. (1) No action to effect compliance by any other means authorized by law shall be taken until:

(i) The designated agency official has determined that compliance cannot be secured by voluntary means;

(ii) The recipient has been notified of its failure to comply and of the action to be taken to effect compliance; and

(iii) The expiration of at least 10 days from the mailing of such notice to the recipient.

(2) During this period of at least 10 days additional efforts shall be made to persuade the recipient to comply with these Title IX regulations and to take such corrective action as may be appropriate.

[65 FR 52887, Aug. 30, 2000]

§ 1211.620 Hearings.

(a) Opportunity for hearing. Whenever an opportunity for a hearing is required by § 1211.615(c), reasonable notice shall be given by registered or certified mail, return receipt requested, to the affected applicant or recipient. This notice shall advise the applicant or recipient of the action proposed to

be taken, the specific provision under which the proposed action against it is to be taken, and the matters of fact or law asserted as the basis for this action, and either:

(1) Fix a date not less than 20 days after the date of such notice within which the applicant or recipient may request of the designated agency official that the matter be scheduled for hearing; or

(2) Advise the applicant or recipient that the matter in question has been set down for hearing at a stated place and time. The time and place so fixed shall be reasonable and shall be subject to change for cause. The complainant, if any, shall be advised of the time and place of the hearing. An applicant or recipient may waive a hearing and submit written information and argument for the record. The failure of an applicant or recipient to request a hearing for which a date has been set shall be deemed to be a waiver of the right to a hearing under 20 U.S.C. 1682 and § 1211.615(c) and consent to the making of a decision on the basis of such information as may be filed as the record.

(b) *Time and place of hearing.* Hearings shall be held at the offices of the agency in Washington, DC, at a time fixed by the designated agency official unless the official determines that the convenience of the applicant or recipient or of the agency requires that another place be selected. Hearings shall be held before a hearing officer designated in accordance with 5 U.S.C. 556(b).

(c) *Right to counsel.* In all proceedings under this section, the applicant or recipient and the agency shall have the right to be represented by counsel.

(d) *Procedures, evidence, and record.* (1) The hearing, decision, and any administrative review thereof shall be conducted in conformity with 5 U.S.C. 554-557 (sections 5 through 8 of the Administrative Procedure Act), and in accordance with such rules of procedure as are proper (and not inconsistent with this section) relating to the conduct of the hearing, giving of notices subsequent to those provided for in paragraph (a) of this section, taking of testimony, exhibits, arguments and briefs, requests for findings, and other related matters. Both the agency and

the applicant or recipient shall be entitled to introduce all relevant evidence on the issues as stated in the notice for hearing or as determined by the hearing officer at the outset of or during the hearing. Any person (other than a Government employee considered to be on official business) who, having been invited or requested to appear and testify as a witness on the Government's behalf, attends at a time and place scheduled for a hearing provided for by these Title IX regulations, may be reimbursed for his or her travel and actual expenses of attendance in an amount not to exceed the amount payable under the standardized travel regulations to a Government employee traveling on official business.

(2) Technical rules of evidence shall not apply to hearings conducted pursuant to these Title IX regulations, but rules or principles designed to assure production of the most credible evidence available and to subject testimony to test by cross-examination shall be applied where reasonably necessary by the hearing officer. The hearing officer may exclude irrelevant, immaterial, or unduly repetitious evidence. All documents and other evidence offered or taken for the record shall be open to examination by the parties and opportunity shall be given to refute facts and arguments advanced on either side of the issues. A transcript shall be made of the oral evidence except to the extent the substance thereof is stipulated for the record. All decisions shall be based upon the hearing record and written findings shall be made.

(e) *Consolidated or joint hearings.* In cases in which the same or related facts are asserted to constitute non-compliance with these Title IX regulations with respect to two or more programs to which these Title IX regulations apply, or noncompliance with these Title IX regulations and the regulations of one or more other Federal departments or agencies issued under Title IX, the designated agency official may, by agreement with such other departments or agencies where applicable, provide for the conduct of consolidated or joint hearings, and for the application to such hearings of rules of procedures not inconsistent with these

## § 1211.625

## 36 CFR Ch. XII (7-1-03 Edition)

Title IX regulations. Final decisions in such cases, insofar as these Title IX regulations are concerned, shall be made in accordance with § 1211.625.

[65 FR 52887, Aug. 30, 2000]

### § 1211.625 Decisions and notices.

(a) *Decisions by hearing officers.* After a hearing is held by a hearing officer such hearing officer shall either make an initial decision, if so authorized, or certify the entire record including recommended findings and proposed decision to the reviewing authority for a final decision, and a copy of such initial decision or certification shall be mailed to the applicant or recipient and to the complainant, if any. Where the initial decision referred to in this paragraph or in paragraph (c) of this section is made by the hearing officer, the applicant or recipient or the counsel for the agency may, within the period provided for in the rules of procedure issued by the designated agency official, file with the reviewing authority exceptions to the initial decision, with the reasons therefor. Upon the filing of such exceptions the reviewing authority shall review the initial decision and issue its own decision thereof including the reasons therefor. In the absence of exceptions the initial decision shall constitute the final decision, subject to the provisions of paragraph (e) of this section.

(b) *Decisions on record or review by the reviewing authority.* Whenever a record is certified to the reviewing authority for decision or it reviews the decision of a hearing officer pursuant to paragraph (a) or (c) of this section, the applicant or recipient shall be given reasonable opportunity to file with it briefs or other written statements of its contentions, and a copy of the final decision of the reviewing authority shall be given in writing to the applicant or recipient and to the complainant, if any.

(c) *Decisions on record where a hearing is waived.* Whenever a hearing is waived pursuant to § 1211.620, the reviewing authority shall make its final decision on the record or refer the matter to a hearing officer for an initial decision to be made on the record. A copy of such decision shall be given in writing

to the applicant or recipient, and to the complainant, if any.

(d) *Rulings required.* Each decision of a hearing officer or reviewing authority shall set forth a ruling on each finding, conclusion, or exception presented, and shall identify the requirement or requirements imposed by or pursuant to these Title IX regulations with which it is found that the applicant or recipient has failed to comply.

(e) *Review in certain cases by the Archivist of the United States.* If the Archivist has not personally made the final decision referred to in paragraph (a), (b), or (c) of this section, a recipient or applicant or the counsel for the agency may request the Archivist to review a decision of the reviewing authority in accordance with rules of procedure issued by the designated agency official. Such review is not a matter of right and shall be granted only where the Archivist determines there are special and important reasons therefor. The Archivist may grant or deny such request, in whole or in part. The Archivist may also review such a decision upon his own motion in accordance with rules of procedure issued by the National Archives and Records Administration. In the absence of a review under this paragraph (e), a final decision referred to in paragraph (a), (b), or (c) of this section shall become the final decision of the agency when the Archivist transmits it as such to Congressional committees with the report required under 20 U.S.C. 1682. Failure of an applicant or recipient to file an exception with the reviewing authority or to request review under this paragraph (e) shall not be deemed a failure to exhaust administrative remedies for the purpose of obtaining judicial review.

(f) *Content of orders.* The final decision may provide for suspension or termination of, or refusal to grant or continue Federal financial assistance, in whole or in part, to which these Title IX regulations apply, and may contain such terms, conditions, and other provisions as are consistent with and will effectuate the purposes of Title IX and these Title IX regulations, including provisions designed to assure that no Federal financial assistance to which these Title IX regulations apply will

thereafter be extended under such law or laws to the applicant or recipient determined by such decision to be in default in its performance of an assurance given by it pursuant to these Title IX regulations, or to have otherwise failed to comply with these Title IX regulations unless and until it corrects its noncompliance and satisfies the designated agency official that it will fully comply with these Title IX regulations.

(g) *Post-termination proceedings.* (1) An applicant or recipient adversely affected by an order issued under paragraph (f) of this section shall be restored to full eligibility to receive Federal financial assistance if it satisfies the terms and conditions of that order for such eligibility or if it brings itself into compliance with these Title IX regulations and provides reasonable assurance that it will fully comply with these Title IX regulations. An elementary or secondary school or school system that is unable to file an assurance of compliance shall be restored to full eligibility to receive Federal financial assistance if it files a court order or a plan for desegregation that meets the applicable requirements and provides reasonable assurance that it will comply with the court order or plan.

(2) Any applicant or recipient adversely affected by an order entered pursuant to paragraph (f) of this section may at any time request the designated agency official to restore fully its eligibility to receive Federal financial assistance. Any such request shall be supported by information showing that the applicant or recipient has met the requirements of paragraph (g)(1) of this section. If the designated agency official determines that those requirements have been satisfied, the official shall restore such eligibility.

(3) If the designated agency official denies any such request, the applicant or recipient may submit a request for a hearing in writing, specifying why it believes such official to have been in error. It shall thereupon be given an expeditious hearing, with a decision on the record, in accordance with rules of

procedure issued by the designated agency official. The applicant or recipient will be restored to such eligibility if it proves at such hearing that it satisfied the requirements of paragraph (g)(1) of this section. While proceedings under this paragraph (g) are pending, the sanctions imposed by the order issued under paragraph (f) of this section shall remain in effect.

[65 FR 52888, Aug. 30, 2000]

**§ 1211.630 Judicial review.**

Action taken pursuant to 20 U.S.C. 1682 is subject to judicial review as provided in 20 U.S.C. 1683.

[65 FR 52889, Aug. 30, 2000]

**§ 1211.635 Forms and instructions; coordination.**

(a) *Forms and instructions.* The designated agency official shall issue and promptly make available to interested persons forms and detailed instructions and procedures for implementing these Title IX regulations.

(b) *Supervision and coordination.* The Archivist or his designee may from time to time assign to officials of the agency, or to officials of other departments or agencies of the Government with the consent of such departments or agencies, responsibilities in connection with the effectuation of the purposes of Title IX and these Title IX regulations (other than responsibility for review as provided in §1211.625(e)), including the achievements of effective coordination and maximum uniformity within the agency and within the Executive Branch of the Government in the application of Title IX and these Title IX regulations to similar programs and in similar situations. Any action taken, determination made, or requirement imposed by an official of another department or agency acting pursuant to an assignment of responsibility under this section shall have the same effect as though such action had been taken by the designated official of this agency.

[65 FR 52889, Aug. 30, 2000]

## SUBCHAPTER B—RECORDS MANAGEMENT

### PART 1220—FEDERAL RECORDS; GENERAL

Sec.

- 1220.1 Scope of subchapter.
- 1220.2 Responsibility for records management programs.

#### Subpart A—General Provisions

- 1220.10 Authority.
- 1220.12 Applicability.
- 1220.14 General definitions.
- 1220.16 Reports to the Congress and the Director of the Office of Management and Budget.
- 1220.18 Inspection of records.

#### Subpart B—Agency Records Management Programs

- 1220.30 Authority.
- 1220.32 Program content.
- 1220.34 Creation of records.
- 1220.36 Maintenance and use of records.
- 1220.38 Disposition of records.
- 1220.40 Liaison offices.
- 1220.42 Agency internal evaluations.

#### Subpart C—NARA Evaluation Program

- 1220.50 Authority.
- 1220.52 Purpose and scope.
- 1220.54 Evaluation process.
- 1220.56 Evaluation report.
- 1220.58 Agency action plans and progress reports.
- 1220.60 Followup notification and reviews.

AUTHORITY: 44 U.S.C. 2104(a) and chs. 29 and 33.

SOURCE: 50 FR 26930, June 28, 1985, unless otherwise noted.

#### § 1220.1 Scope of subchapter.

Subchapter B prescribes policies for Federal agencies' records management programs relating to records creation and maintenance, adequate documentation, and proper records disposition.

#### § 1220.2 Responsibility for records management programs.

The National Archives and Records Administration Act of 1984 amended the records management statutes to divide records management responsibilities between the National Archives and Records Administration (NARA)

and the General Services Administration (GSA). Under the Act, NARA is responsible for adequacy of documentation and records disposition and GSA is responsible for economy and efficiency in records management. NARA regulations are codified in this subchapter. GSA records management regulations are codified in 41 CFR part 102-193. Federal agency records management programs must be in compliance with regulations promulgated by both NARA and GSA.

[57 FR 19807, May 8, 1992, as amended at 67 FR 31962, May 13, 2002]

#### Subpart A—General Provisions

##### § 1220.10 Authority.

The regulations in this part are issued under the provisions of the National Archives and Records Administration Act of 1984 (Pub. L. 98-497, 44 U.S.C. 101 *note*).

##### § 1220.12 Applicability.

The regulations in subchapter B apply to all Federal agencies as defined in § 1220.14.

##### § 1220.14 General definitions.

As used in subchapter B—*Agency* (see *Executive agency* and *Federal agency*).

*Adequate and proper documentation* means a record of the conduct of Government business that is complete and accurate to the extent required to document the organization, functions, policies, decisions, procedures, and essential transactions of the agency and that is designed to furnish the information necessary to protect the legal and financial rights of the Government and of persons directly affected by the agency's activities.

*Appraisal* is the process by which the National Archives and Records Administration (NARA) determines the value and thus the final disposition of Federal records, making them either temporary or permanent.

*Commercial records storage facility* is a private sector commercial facility that

offers records storage, retrieval, and disposition services.

*Comprehensive schedule* is a printed agency manual or directive containing descriptions of and disposition instructions for all documentary materials, record and nonrecord, created by a Federal agency or major component of an Executive department. Unless taken from the General Records Schedules (GRS) issued by NARA, the disposition instructions for agency records must be approved by NARA on one or more Standard Form(s) 115, Request for Records Disposition Authority, prior to issuance by the agency. The disposition instructions for the nonrecord material are established by the agency and do not require NARA approval.

*Contingent records* are records whose final disposition is dependent on an action or event, such as sale of property or destruction of a facility, which will take place at some unspecified time in the future.

*Disposition* means those actions taken regarding records no longer needed for the conduct of the regular current business of the agency.

*Documentary materials* is a collective term for records and nonrecord materials that refers to all media on which information is recorded, regardless of the nature of the medium or the method or circumstances of recording.

*Evaluation* means the selective or comprehensive inspection, audit, or review of one or more Federal agency records management programs for effectiveness and for compliance with applicable laws and regulations. It includes recommendations for correcting or improving records management policies, procedures, and activities, and follow-up activities, including reporting on such activities, for implementing the recommendations.

*Executive agency* means any executive department or independent establishment in the executive branch of the Government, including any wholly-owned Government corporation.

*Federal agency* means any executive agency or any establishment in the legislative or judicial branch of the Government (except the Supreme Court, Senate, the House of Representatives, and the Architect of the Capitol and

any activities under his direction). (44 U.S.C. 2901(14)).

*File* means an arrangement of records. The term is used to denote papers, photographs, photographic copies, maps, machine-readable information, or other recorded information regardless of physical form or characteristics, accumulated or maintained in filing equipment, boxes, or machine-readable media, or on shelves, and occupying office or storage space.

*National Archives of the United States* means those records that have been determined by the Archivist of the United States to have sufficient historical or other value to warrant their continued preservation by the Federal Government and that have been transferred to the legal custody of the Archivist of the United States on a Standard Form 258 (Agreement to Transfer Records to the National Archives of the United States).

*Nonrecord materials* are those Federally owned informational materials that do not meet the statutory definition of records (44 U.S.C. 3301) or that have been excluded from coverage by the definition. Excluded materials are extra copies of documents kept only for reference, stocks of publications and processed documents, and library or museum materials intended solely for reference or exhibit.

*Permanent record* means any Federal record that has been determined by NARA to have sufficient value to warrant its preservation in the National Archives of the United States. Permanent records include all records accessioned by NARA into the National Archives of the United States and later increments of the same records, and those for which the disposition is permanent on SF 115s, Request for Records Disposition Authority, approved by NARA on or after May 14, 1973.

*Recordkeeping requirements* means all statements in statutes, regulations, and agency directives or authoritative issuances, that provide general and specific requirements for Federal agency personnel on particular records to be created and maintained by the agency.

*Recordkeeping system* is a manual or automated system in which records are

collected, organized, and categorized to facilitate their preservation, retrieval, use, and disposition.

*Records* include all books, papers, maps, photographs, machine readable materials, or other documentary materials, regardless of physical form or characteristics, made or received by an agency of the United States Government under Federal law or in connection with the transaction of public business and preserved or appropriate for preservation by that agency or its legitimate successor as evidence of the organization, functions, policies, decisions, procedures, operations or other activities of the Government or because of the informational value of the data in them (44 U.S.C. 3301).

*Records center* is defined in 44 U.S.C. 2901(6) as an establishment maintained and operated by the Archivist or by another Federal agency primarily for the storage, servicing, security, and processing of records which need to be preserved for varying periods of time and need not be retained in office equipment or space.

*Records maintenance and use*, as used in subchapter B, means any activity involving location of records of a Federal agency or the storage, retrieval, and handling of records kept at office file locations by or for a Federal agency.

*Records management*, as used in subchapter B, means the planning, controlling, directing, organizing, training, promoting, and other managerial activities involved with respect to records creation, records maintenance and use, and records disposition in order to achieve adequate and proper documentation of the policies and transactions of the Federal Government and effective and economical management of agency operations.

*Records schedule* or *schedule* means

(a) An SF 115, Request for Records Disposition Authority, that has been approved by NARA to authorize the disposition of Federal records;

(b) A General Records Schedule (GRS) issued by NARA; or

(c) A printed agency manual or directive containing the records descriptions and disposition instructions approved by NARA on one or more SF 115s or issued by NARA in the GRS.

(See also the definition *Comprehensive schedule*.)

*Records storage facility* is a records center or a commercial records storage facility, as defined in this section, i.e., a facility used by a Federal agency to store Federal records, whether that facility is operated and maintained by the agency, by NARA, by another Federal agency, or by a private commercial entity.

*Series* means file units or documents arranged according to a filing system or kept together because they relate to a particular subject or function, result from the same activity, document a specific kind of transaction, take a particular physical form, or have some other relationship arising out of their creation, receipt, or use, such as restrictions on access and use. Also called a *records series*.

*Temporary records*. A temporary record is any record which has been determined by the Archivist of the United States to have insufficient value (on the basis of current standards) to warrant its preservation by the National Archives and Records Administration. This determination may take the form of:

(a) A series of records designated as disposable in an agency records disposition schedule approved by NARA (Standard Form 115, Request for Records Disposition Authority); or

(b) A series of records designated as disposable in a General Records Schedule.

*Unscheduled records* are records the final disposition of which has not been approved by NARA. Unscheduled records are those that have not been included on a Standard Form 115, Request for Records Disposition Authority, approved by NARA; those described but not authorized for disposal on an SF 115 approved prior to May 14, 1973; and those described on an SF 115 but not approved by NARA (withdrawn, canceled, or disapproved).

[45 FR 5705, Jan. 24, 1980 and 50 FR 26931, 26933, June 28, 1985, as amended at 52 FR 34134, Sept. 9, 1987; 55 FR 27423, 27427, July 2, 1990; 57 FR 19807, May 8, 1992; 59 FR 28783, June 3, 1994; 60 FR 44639, Aug. 28, 1995; 64 FR 67663, Dec. 2, 1999; 66 FR 27027, May 16, 2001]



**§ 1220.16 Reports to the Congress and the Director of the Office of Management and Budget.**

Under 44 U.S.C. 2904(c)(8), the Archivist of the United States is required to report to Congress and the Office of Management and Budget annually on the results of records management activities, including evaluations of responses by Federal agencies to any recommendations resulting from studies or inspections conducted by NARA.

**§ 1220.18 Inspection of records.**

(a) In order for NARA to conduct inspections and studies required in 44 U.S.C. Chapter 29 and records appraisals in 44 U.S.C. Chapter 33, agencies must provide access for authorized NARA staff members to records in the agency's legal custody, regardless of the physical location of the records.

(b) In accordance with 44 U.S.C. 2906, when NARA inspects an agency record which is contained in a system of records subject to the Privacy Act of 1974 (5 U.S.C. 552a), the records shall be maintained by the Archivist or his designee as a record contained in a system of records or considered to be a record contained in a system of records for the purposes of subsections (b), (c), and (i) of section 552a of title 5.

[50 FR 26930, June 28, 1985, as amended at 64 FR 67664, Dec. 2, 1999]

**Subpart B—Agency Records Management Programs**

**§ 1220.30 Authority.**

Section 3101 of title 44 U.S.C. requires the head of each Federal agency to make and preserve records containing adequate and proper documentation of the organization, functions, policies, decisions, procedures and essential transactions of the agency and designed to furnish the information necessary to protect the legal and financial rights of the Government and of persons directly affected by the agency's activities.

**§ 1220.32 Program content.**

Agency programs shall, among other things, provide for:

(a) Cooperation with NARA in developing and applying standards, proce-

dures, and techniques designed to improve the management of records, promote the maintenance and security of records deemed appropriate for permanent preservation, and facilitate the segregation and disposal of temporary records.

(b) Compliance with sections 2101-2117, 2501-2507, 2901-2909, 3101-3107, and 3301-3314 of title 44 U.S.C. and with NARA regulations issued in title 36 of the Code of Federal Regulations.

**§ 1220.34 Creation of records.**

Adequate records management controls over the creation of Federal agency records shall be instituted to ensure that agency functions are adequately and properly documented. Federal agencies shall also comply with GSA regulations on creation of records found in 41 CFR part 102-193.

[57 FR 19807, May 8, 1992, as amended at 67 FR 31962, May 13, 2002]

**§ 1220.36 Maintenance and use of records.**

(a) Agencies must institute adequate records management controls over the maintenance and use of records wherever they are located to ensure that all records, regardless of format or medium, are organized, classified, and described to promote their accessibility, and make them available for use by all appropriate agency staff for their authorized retention period. Agencies must also maintain permanent records in a format that will permit transfer to the National Archives of the United States.

(b) Agencies must ensure that they maintain adequate information about their records moved to an off-site records storage facility (see 36 CFR 1228.154). Agencies must also create and maintain records that document the destruction of temporary records and the transfer of permanent records to the National Archives of the United States. The disposition of records that provide such documentation is governed by General Records Schedule (GRS) 16.

(c) Agencies must also comply with GSA regulations on the maintenance

### § 1220.38

and use of records found in 41 CFR part 102-193.

[64 FR 67664, Dec. 2, 1999, as amended at 67 FR 31962, May 13, 2002]

#### § 1220.38 Disposition of records.

(a) Agencies must ensure the proper, authorized disposition of their records, regardless of format or medium, so that permanent records are preserved and temporary records no longer of use to an agency are promptly deleted or disposed of in accordance with the approved records schedule when their required retention period expires. As an intermediate step when records are not needed for current day-to-day reference, they may be transferred to a records storage facility.

(b) Agencies must secure NARA approval of a records schedule or apply the appropriate General Records Schedule item before destroying any temporary records or transferring permanent records to the National Archives of the United States (see 36 CFR part 1228).

[64 FR 67664, Dec. 2, 1999]

#### § 1220.40 Liaison offices.

An office or offices within each Federal agency shall be assigned responsibility for the development of the records management program required by this part. The office to which responsibility is assigned shall be reported to the NARA Life Cycle Management Division (NWML), 8601 Adelphi Rd., College Park, MD 20740-6001. The name, title, and telephone number of the official or officials authorized by the head of the agency to approve records disposition schedules and transfers of records to the custody of the National Archives shall also be submitted to the Life Cycle Management Division.

[50 FR 26930, June 28, 1985, as amended at 63 FR 35829, July 1, 1998]

#### § 1220.42 Agency internal evaluations.

Each agency must periodically evaluate its records management programs relating to records creation and record keeping requirements, maintenance and use of records, and records disposition. These evaluations shall include periodic monitoring of staff determina-

### 36 CFR Ch. XII (7-1-03 Edition)

tions of the record status of documentary materials in all media, and implementation of these decisions. These evaluations should determine compliance with NARA regulations in this subchapter, including requirements for storage of agency records and records storage facilities in 36 CFR part 1228, subparts I and K, and assess the effectiveness of the agency's records management program.

[64 FR 67664, Dec. 2, 1999]

### Subpart C—NARA Evaluation Program

SOURCE: 59 FR 28783, June 3, 1994, unless otherwise noted.

#### § 1220.50 Authority.

44 U.S.C. chapter 29 vests in the Archivist of the United States the responsibility for providing guidance and assistance to Federal agencies with respect to ensuring adequate and proper documentation and proper records disposition. Sections 2904 and 2906 specifically authorize the Archivist to conduct inspections or surveys of records and records management programs and practices within and between Federal agencies and require officers and employees of agencies to cooperate fully in such inspections. Section 2904 also authorizes the Archivist to report to the appropriate oversight and appropriations committees of the Congress and the Director of OMB on the results of inspections, the responses by agencies to NARA evaluation recommendations, and estimates of the costs to the Federal government resulting from the failure to implement such recommendations.

#### § 1220.52 Purpose and scope.

(a) NARA evaluations assess how effectively Federal agencies make and preserve complete and accurate records of their organization, functions, policies, decisions, procedures, and essential transactions; and maintain an active, continuing records management program including proper records disposition. Agencies shall be evaluated for compliance with requirements in 44 U.S.C. chapters 31 and 33 and all the

regulations issued thereunder in 36 CFR subchapter B.

(b) NARA evaluations may include comprehensive reviews of agency records management programs, or selective reviews focused on adequate and proper documentation, on records disposition, on the management of specific types of record media or on the management of records in particular program areas. NARA evaluations may be of one agency or may be multi-agency. These evaluations may be conducted solely within headquarters offices, only at field locations, or at a combination of field sites and headquarters.

(c) Evaluations will involve site visits by NARA; submission by NARA to the agency of a written report containing findings, analyses, and recommendations; and submission to NARA by the agency of an action plan for implementing the recommendations followed by regular progress reports. Interagency report control number 0153-NARA-AR has been assigned to the action plan and progress reports in accordance with GSA regulations in Title 41 of the CFR.

[59 FR 28783, June 3, 1994, as amended at 66 FR 27027, May 16, 2001]

#### § 1220.54 Evaluation process.

(a) NARA shall select Federal agencies to be evaluated on the basis of perceived need by NARA or specific request by the agency, or on the basis of a compliance monitoring cycle developed by NARA. NARA will determine the scope of the evaluation. An agency may request an evaluation of its records management program by contacting the Director, Life Cycle Management Division; however, the final determination of agencies to be evaluated will be made by NARA. The heads of agencies will be notified in writing by the Archivist of the United States of the intent to conduct an evaluation and the scope of the evaluation at least 180 calendar days prior to initiating the evaluation.

(b) Once NARA has notified the agency, the agency head will, by the date specified in the Archivist's letter:

(1) Acknowledge in writing NARA's intention to evaluate, and provide the Archivist with the name and telephone

number of the senior official with overall responsibility for records management and of a headquarters official who will work with NARA to facilitate the evaluation process;

(2) Provide written notification of the evaluation to all appropriate offices and employees and contractors potentially involved; this notification will include instructions to cooperate with NARA by setting up interviews, providing requested information, and making records available for inspection;

(3) Provide NARA with a copy of the written notification in paragraph (b)(2) of this section and with a list of names and telephone numbers of officials responsible for records management in field sites, if applicable, who will work with NARA during the evaluation;

(4) For comprehensive evaluations, provide NARA with a set of internal records management directives, orders, bulletins, or similar authoritative issuances; copies of the two most recent internal records management evaluations; and any special records-related reports. Included may be: issuances relating to adequate and proper documentation and record-keeping requirements; personal papers; management and disposition of textual, electronic, audiovisual, cartographic and architectural, micrographic, and vital records; disaster mitigation and recovery; and any other records-related documentation requested by NARA. A subset of this documentation will be requested for more limited evaluations;

(5) Provide NARA with a current version of the agency manual(s) covering records creation, maintenance, storage, and disposition, and a list of information systems maintained as required by OMB Circular A-130, section 9a(5), and a list of offices and/or functions and activities not currently covered by schedules;

(6) Arrange for appropriate management and program officials in headquarters and, if applicable, at field sites to be briefed by NARA at the beginning and at the end of the evaluation process; and

(7) Take immediate corrective action regarding any serious problems that

## § 1220.56

NARA may bring to the agency's attention during the course of the evaluation process such as the unauthorized destruction of records or the unauthorized donation or other transfer of records to non-NARA facilities.

[59 FR 28783, June 3, 1994, as amended at 63 FR 35829, July 1, 1998]

### § 1220.56 Evaluation report.

(a) NARA will submit a draft evaluation report for factual review and comment to the agency within 120 calendar days of the last evaluation site visit or exit briefing. After receipt of agency comments, NARA will finalize the report, incorporating any changes resulting from factual errors identified by the agency. The final report will be transmitted by the Archivist to the head of the agency within 30 calendar days of receiving comments from the agency.

(b) The head of the agency will:

(1) Comment within 60 calendar days, in writing, on the contents of the draft report. If necessary, agencies can request extensions. No response from the agency within the allotted time will indicate that the agency concurs in the factual accuracy of the draft report.

(2) Review the final report and assign implementation responsibility; and

(3) Distribute the final report to all concerned and appropriate persons and offices.

### § 1220.58 Agency action plans and progress reports.

(a) *Action plans.* (1) The action plan will be submitted to NARA within 90 calendar days after the date of transmittal of the final report. If necessary, agencies can request extensions. The plan shall be submitted by the agency head or the designated senior official for information resources management. The action plan will include:

(i) The name of the senior official and the office responsible for coordinating implementation agency-wide;

(ii) The specific action(s) the agency will take to implement each evaluation report recommendation. If an agency is unable to implement a recommendation, the rationale for not acting shall be documented in the action plan;

(iii) The name of the official and office or program responsible for the

## 36 CFR Ch. XII (7-1-03 Edition)

overall coordination of the agency's followup actions who will be the liaison with NARA;

(iv) The estimated time needed to complete each action and the proposed quarter and year for starting and completing each action;

(v) Major milestones with dates for tracking the completion of implementation actions that are expected to extend longer than 3 years past the date of the action plan; and,

(vi) If requested by NARA, separate action plans for each field site visited, incorporating the information required by paragraphs (a)(1)(i) through (a)(1)(v) of this section.

(2) NARA will analyze the action plan(s) submitted by the agency for adequacy and effectiveness in implementing the recommendations contained in the evaluation report. NARA will provide comments to the agency on the plan(s) within 60 calendar days.

(3) The agency will revise the action plan until it is approved by NARA.

(b) *Progress reports.* (1) Once the action plan(s) has been approved by NARA, the head of the agency will submit progress reports to NARA every 6 months. The reports will include:

(i) A description of what has been accomplished on each action since the last report;

(ii) The current status of the action;

(iii) Any changes in the offices or programs responsible for over-all or specific action implementation; and,

(iv) If appropriate, explanation of any delays in implementation and revised target dates and milestones for completion of the action.

(2) The agency will continue to submit these progress reports until NARA and the agency agree all actions have been completed, NARA and the agency agree that the agency has implemented the recommendation(s) to the fullest extent possible, or NARA indicates in writing that regular progress reports are no longer required.

(3) NARA will review and comment on agency progress reports, and work closely with the agency to provide assistance in evaluation implementation.

**§ 1220.60 Follow-up notification and reviews.**

(a) If NARA determines that there is not substantial progress in the full implementation of evaluation recommendations or that the agency has not corrected serious problems identified in the report, the Archivist, after notifying the head of the agency, may notify Congress and appropriate Federal oversight agencies of the evaluation findings and the agency response.

(b) NARA may initiate follow-up reviews at specific offices or field sites. Results of these follow-up reviews shall be communicated to the head of the agency and, if NARA determines it to be appropriate, to Congress and Federal oversight agencies.

**PART 1222—CREATION AND MAINTENANCE OF FEDERAL RECORDS****Subpart A—General**

Sec.

1222.10 Authority.

1222.12 Defining Federal records.

**Subpart B—Program Requirements**

1222.20 Agency responsibilities.

**Subpart C—Standards for Agency Recordkeeping Requirements**

1222.30 Purpose.

1222.32 General requirements.

1222.34 Identifying Federal records.

1222.36 Identifying personal papers.

1222.38 Categories of documentary materials to be covered by recordkeeping requirements.

1222.40 Removal of records.

1222.42 Removal of nonrecord materials.

1222.44 Directives documenting agency programs, policies, and procedures.

1222.46 Recordkeeping requirements of other agencies.

1222.48 Data created or received and maintained for the Government by contractors.

1222.50 Records maintenance and storage.

AUTHORITY: 44 U.S.C. 2904, 3101, and 3102.

SOURCE: 55 FR 27423, July 2, 1990, unless otherwise noted.

**Subpart A—General****§ 1222.10 Authority.**

(a) 44 U.S.C. 2904, vests in the Archivist of the United States responsibility

for providing guidance and assistance to Federal agencies with respect to ensuring adequate and proper documentation of the policies and transactions of the Federal Government, including developing and issuing standards to improve the management of records.

(b) 44 U.S.C. 3101, requires that the head of each Federal agency shall make and preserve records containing adequate and proper documentation of the organization, functions, policies, decisions, procedures, and essential transactions of the agency and designed to furnish the information necessary to protect the legal and financial rights of the Government and of persons directly affected by the agency's activities.

(c) 44 U.S.C. 3102, requires that the head of each Federal agency shall establish and maintain an active, continuing program for the economical and efficient management of the records of the agency. The program, among other things, shall provide for—

(1) Effective controls over the creation, and over the maintenance and use of records in the conduct of current business;

(2) Cooperation with the Administrator of General Services and the Archivist in applying standards, procedures, and techniques designed to improve the management of records, promote the maintenance and security of records deemed appropriate for preservation, and facilitate the segregation and disposal of records of temporary value.

**§ 1222.12 Defining Federal records.**

(a) The statutory definition of Federal records is contained in 44 U.S.C. 3301 and is stated in § 1220.14 of this chapter.

(b) Several key terms, phrases, and concepts in the statutory definition of records are defined as follows:

(1) *Documentary materials* is a collective term for records, nonrecord materials, and personal papers that refers to all media containing recorded information, regardless of the nature of the media or the method(s) or circumstance(s) of recording.

(2) *Regardless of physical form or characteristics* means that the medium may be paper, film, disk, or other physical

type or form; and that the method of recording may be manual, mechanical, photographic, electronic, or any other combination of these or other technologies.

(3) *Made* means the act of creating and recording information by agency personnel in the course of their official duties, regardless of the method(s) or the medium involved. The act of recording is generally identifiable by the circulation of the information to others or by placing it in files accessible to others.

(4) *Received* means the acceptance or collection of documentary materials by agency personnel in the course of their official duties regardless of their origin (for example, other units of their agency, private citizens, public officials, other agencies, contractors, Government grantees) and regardless of how transmitted (in person or by messenger, mail, electronic means, or by any other method). In this context, the term does not refer to misdirected materials. It may or may not refer to loaned or seized materials depending on the conditions under which such materials came into agency custody or were used by the agency. Advice of legal counsel should be sought regarding the “record” status of loaned or seized materials.

(5) *Preserved* means the filing, storing, or any other method of systematically maintaining documentary materials by the agency. This term covers materials not only actually filed or otherwise systematically maintained but also those temporarily removed from existing filing systems.

(6) *Appropriate for preservation* means documentary materials made or received which in the judgment of the agency should be filed, stored, or otherwise systematically maintained by an agency because of the evidence of agency activities or information they contain, even though the materials may not be covered by its current filing or maintenance procedures.

[55 FR 27423, July 2, 1990; 55 FR 31982, Aug. 6, 1990]

## Subpart B—Program Requirements

### § 1222.20 Agency responsibilities.

(a) The head of each Federal agency, in meeting the requirements of 44 U.S.C. 2904, 3101, and 3102, shall observe the responsibilities and standards set forth in this part. Agencies are also subject to regulations issued by the General Services Administration (GSA) in 41 CFR part 102-193.

(b) Each Federal agency shall:

(1) Assign to one or more offices of the agency the responsibility for the development and implementation of agency-wide programs to identify, develop, issue, and periodically review recordkeeping requirements for records for all agency activities at all levels and locations in all media including paper, microform, audiovisual, cartographic, and electronic (including those created or received using electronic mail);

(2) Integrate programs for the identification, development, issuance, and periodic review of recordkeeping requirements with other records and information resources management programs of the agency, including the requirement of close coordination between the office designated in 36 CFR 1222.20(b)(1) and the office assigned overall records management responsibility in accordance with 36 CFR 1220.40, if the two are different;

(3) Issue a directive(s) establishing program objectives, responsibilities, and authorities for agency recordkeeping requirements. Copies of the directive(s) (including subsequent amendments or supplements) shall be disseminated throughout the agency, as appropriate, and a copy shall be sent to NARA (NWML);

(4) Establish procedures for the participation of records management officials in developing new or revised agency programs, processes, systems, and procedures in order to ensure that adequate recordkeeping requirements are established and implemented;

(5) Ensure that adequate training is provided to all agency personnel on

policies, responsibilities, and techniques for the implementation of recordkeeping requirements and the distinction between records and nonrecord materials, regardless of media, including those materials created by individuals using computers to send or receive electronic mail;

(6) Develop and implement records schedules for all records created and received by the agency and obtain NARA approval of the schedules in accordance with 36 CFR part 1228;

(7) Ensure compliance with applicable Governmentwide policies, procedures, and standards relating to recordkeeping requirements as may be issued by the Office of Management and Budget, the General Services Administration, the National Archives and Records Administration, the National Institute of Standards and Technology, or other agencies, as appropriate;

(8) Review recordkeeping requirements, as part of the periodic information resources management reviews required by 44 U.S.C. 3506, or the periodic records management evaluations required by 36 CFR 1220.54, in order to validate their currency and to ensure that recordkeeping requirements are being implemented;

(9) Remind all employees annually of the agency's recordkeeping policies and of the sanctions provided for the unlawful removal or destruction of Federal records (18 U.S.C. 2071);

(10) Ensure that records storage facilities used to store the agency's records comply with the standards specified in 36 CFR part 1228, subpart K. The agency must also comply with 36 CFR 1228.240 by obtaining NARA approval of an agency records center or submitting documentation of compliance by a commercial records storage facility before the agency transfers records to that facility.

[55 FR 27423, July 2, 1990, as amended at 58 FR 49194, Sept. 22, 1993; 60 FR 44640, Aug. 28, 1995; 63 FR 35829, July 1, 1998; 64 FR 67664, Dec. 2, 1999; 67 FR 31962, May 13, 2002]

### Subpart C—Standards for Agency Recordkeeping Requirements

#### § 1222.30 Purpose.

(a) The clear articulation of recordkeeping requirements by Federal agen-

cies is essential if agencies are to meet the requirements of 44 U.S.C. 3101 and 3102 with respect to creating, receiving, maintaining, and preserving adequate and proper documentation, and with respect to maintaining an active, continuing program for the economical and efficient management of agency records.

(b) Although many agencies regularly issue recordkeeping requirements for routine operations, many do not adequately specify such requirements for documenting policies and decisions, nor do they provide sufficient guidance on distinguishing between records and nonrecord materials, and maintaining records created or received on electronic mail systems.

(c) Since agency functions, activities, and administrative practices vary so widely, NARA cannot issue a comprehensive list of all categories of documentary materials appropriate for preservation by an agency as evidence of its activities or because of the information they contain. In all cases, the agency must consider the intent or circumstances of creation or receipt of the materials to determine whether their systematic maintenance shall be required.

[55 FR 27423, July 2, 1990, as amended at 60 FR 44640, Aug. 28, 1995]

#### § 1222.32 General requirements.

Agencies shall identify, develop, issue, and periodically review their recordkeeping requirements for all agency operations and for records in all media, including those records created or received on electronic mail systems. Recordkeeping requirements shall:

(a) Identify and prescribe specific categories of documentary materials to be systematically created or received and maintained by agency personnel in the course of their official duties;

(b) Prescribe the use of materials and recording techniques that ensure the preservation of records as long as they are needed by the Government;

(c) Prescribe the manner in which these materials shall be maintained wherever held; and

(d) Distinguish records from non-record materials and, with the approval of the Archivist of the United States, prescribe action for the final

## § 1222.34

disposition of agency records when they are no longer needed for current business.

[55 FR 27423, July 2, 1990, as amended at 60 FR 44640, Aug. 28, 1995]

### § 1222.34 Identifying Federal records.

(a) *General.* To ensure that complete and accurate records are made and retained in the Federal Government, it is essential that agencies distinguish between records and nonrecord materials by the appropriate application of the definition of records (see 44 U.S.C. 3301 and 36 CFR 1220.14) to agency documentary materials. Applying the definition of records to most documentary materials created or received by agencies presents few problems when agencies have established and periodically updated recordkeeping requirements covering all media and all agency activities at all levels and locations.

(b) *Record status.* Documentary materials are records when they meet both of the following conditions:

(1) They are made or received by an agency of the United States Government under Federal law or in connection with the transaction of agency business; and

(2) They are preserved or are appropriate for preservation as evidence of agency organization and activities or because of the value of the information they contain.

(c) *Working files and similar materials.* Working files, such as preliminary drafts and rough notes, and other similar materials shall be maintained for purposes of adequate and proper documentation if:

(1) They were circulated or made available to employees, other than the creator, for official purposes such as approval, comment, action, recommendation, follow-up, or to communicate with agency staff about agency business; and

(2) They contain unique information, such as substantive annotations or comments included therein, that adds to a proper understanding of the agency's formulation and execution of basic policies, decisions, actions, or responsibilities.

(d) *Record status of copies.* The determination as to whether a particular document is a record does not depend

## 36 CFR Ch. XII (7-1-03 Edition)

upon whether it contains unique information. Multiple copies of the same document and documents containing duplicative information, including messages created or received on electronic mail systems, may each have record status depending on how they are used to transact agency business. See paragraph (f)(2) of this section concerning the nonrecord status of extra copies.

(e) *Electronic mail messages.* Messages created or received on electronic mail systems may meet the definition of record in 44 U.S.C. 3301.

(f) *Nonrecord materials.* Nonrecord materials are Government-owned documentary materials that do not meet the conditions of record status (see § 1222.34(b)) or that are specifically excluded from status as records by statute (see 44 U.S.C. 3301):

(1) Library and museum material (but only if such material is made or acquired and preserved solely for reference or exhibition purposes);

(2) Extra copies of documents (but only if the sole reason such copies are preserved is for convenience of reference); and

(3) Stocks of publications and of processed documents. (Each agency shall create and maintain serial or record sets of its publications and processed documents, as evidence of agency activities and for the information they contain, including annual reports, brochures, pamphlets, books, handbooks, posters and maps.)

(g) *Agency responsibilities.* Agencies shall take appropriate action to ensure that all staff are capable of identifying Federal records. For electronic mail systems, agencies shall ensure that all staff are informed of the potential record status of messages, transmittal and receipt data, directories, and distribution lists.

[55 FR 27423, July 2, 1990, as amended at 60 FR 44640, Aug. 28, 1995]

### § 1222.36 Identifying personal papers.

(a) Personal papers are documentary materials, or any reasonably segregable portion thereof, of a private or nonpublic character that do not relate to, or have an effect upon, the conduct of agency business. Personal papers are excluded from the definition of Federal



records and are not owned by the Government. Examples of personal papers include:

(1) Materials accumulated by an official before joining Government service that are not used subsequently in the transaction of Government business;

(2) Materials relating solely to an individual's private affairs, such as outside business pursuits, professional affiliations, or private political associations that do not relate to agency business; and

(3) Diaries, journals, personal correspondence, or other personal notes that are not prepared or used for, or circulated or communicated in the course of, transacting Government business.

(b) Personal papers shall be clearly designated as such and shall at all times be maintained separately from the office's records.

(c) If information about private matters and agency business appears in the same document, the document shall be copied at the time of receipt, with the personal information deleted, and treated as a Federal record.

(d) Materials labeled "personal," "confidential," or "private," or similarly designated, and used in the transaction of public business, are Federal records subject to the provisions of pertinent laws and regulations. The use of a label such as "personal" is not sufficient to determine the status of documentary materials in a Federal office.

[55 FR 27423, July 2, 1990; 55 FR 28136, July 9, 1990; 55 FR 31982, Aug. 6, 1990]

**§ 1222.38 Categories of documentary materials to be covered by recordkeeping requirements.**

Agency recordkeeping requirements shall prescribe the creation and maintenance of records of the transaction of agency business that are sufficient to:

(a) Document the persons, places, things, or matters dealt with by the agency.

(b) Facilitate action by agency officials and their successors in office.

(c) Make possible a proper scrutiny by the Congress or other duly authorized agencies of the Government.

(d) Protect the financial, legal, and other rights of the Government and of

persons directly affected by the Government's actions.

(e) Document the formulation and execution of basic policies and decisions and the taking of necessary actions, including all significant decisions and commitments reached orally (person to person, by telecommunication, or in conference).

(f) Document important board, committee, or staff meetings.

**§ 1222.40 Removal of records.**

Agencies shall develop procedures to ensure that departing officials do not remove Federal records from agency custody.

**§ 1222.42 Removal of nonrecord materials.**

(a) Nonrecord materials, including extra copies of agency records kept only for convenience of reference, may be removed from Government agencies only with the approval of the head of the agency or the individual authorized to act for the agency on matters pertaining to agency records.

(b) Agencies shall ensure that when nonrecord material containing classified information is removed from the executive branch, it is protected under conditions equivalent to those required of executive branch agencies. The originating agency or its successor in function retains control over access to such classified information, even after it is properly removed from the agency.

(c) Agencies shall ensure the appropriate protection of nonrecord material containing information which is restricted from release under the Privacy Act or other statutes, when such restricted nonrecord material is removed from Government agencies.

[56 FR 26336, June 7, 1991]

**§ 1222.44 Directives documenting agency programs, policies, and procedures.**

Agency recordkeeping requirements shall prescribe that the programs, policies, and procedures of the agency shall be adequately documented in appropriate directives. A record copy of each

**§ 1222.46**

such directive (including those superseded) shall be maintained by the appropriate agency directives management officer(s) as part of the official files.

**§ 1222.46 Recordkeeping requirements of other agencies.**

When statutes, regulations, directives or authoritative issuances of other agencies prescribe an agency's recordkeeping requirements, the agency so affected shall include these in appropriate directives or other authoritative issuances prescribing its organization, functions, or activities.

**§ 1222.48 Data created or received and maintained for the Government by contractors.**

(a) Contractors performing Congressionally-mandated program functions are likely to create or receive data necessary to provide adequate and proper documentation of these programs and to manage them effectively. Agencies shall specify the delivery of the Government of all data needed for the adequate and proper documentation of contractor-operated programs in accordance with requirements of the Federal Acquisition Regulation (FAR) and, where applicable, the Defense Federal Acquisition Regulation Supplement (DFARS).

(b) When contracts involve the creation of data for the Government's use, in addition to specifying a final product, agency officials may need to specify the delivery of background data that may have reuse value to the Government. Before specifying the background data that contractors must deliver to the agency, program and contracting officials shall consult with agency records and information managers and historians and, when appropriate, with other Government agencies to ensure that all agency and Government needs are met, especially when the data deliverables support a new agency mission or a new Government program.

(c) Deferred ordering and delivery-of-data clauses and rights-in-data clauses shall be included in contracts whenever necessary to ensure adequate and proper documentation or because the data have reuse value to the Government.

**36 CFR Ch. XII (7-1-03 Edition)**

(d) When data deliverables include electronic records, the agency shall require the contractor to deliver sufficient technical documentation to permit the agency or other Government agencies to use the data.

(e) All data created for Government use and delivered to, or falling under the legal control of, the Government are Federal records and shall be managed in accordance with records management legislation as codified at 44 U.S.C. chapters 21, 29, 31, and 33, the Freedom of Information Act (5 U.S.C. 552), and the Privacy Act (5 U.S.C. 552a), and shall be scheduled for disposition in accordance with 36 CFR part 1228.

**§ 1222.50 Records maintenance and storage.**

(a) Agencies shall prescribe an appropriate records maintenance program so that complete records are filed or otherwise identified and preserved, records can be found when needed, the identification and retention of permanent records are facilitated, and permanent and temporary records are physically segregated or, for electronic records, segregable.

(b) Each Federal agency, in providing for effective controls over the maintenance of records, shall:

(1) Establish and implement standards and procedures for classifying, indexing, and filing records as set forth in GSA and NARA handbooks;

(2) Formally specify official file locations for records in all media and prohibit the maintenance of records at unauthorized locations;

(3) Formally specify which officials are responsible for maintenance and disposition of electronic records and which computer systems are used for recordkeeping;

(4) Standardize reference service procedures to facilitate the finding, charging out, and refiling of paper, audiovisual, and cartographic and architectural records, and to ensure that reference to electronic records minimizes the risk of unauthorized additions, deletions, or alterations;

(5) Make available to all agency employees published standards, guides, and instructions designed for easy reference and revision;

(6) Review its records maintenance program periodically to determine its adequacy; audit a representative sample of its paper, audiovisual, electronic, cartographic, and architectural files for duplication, misclassification, or misfiles;

(7) Maintain microform, audiovisual, and electronic records in accordance with 36 CFR parts 1230, 1232, and 1234, respectively;

(8) Establish and implement procedures for maintaining records and non-record materials separately; ensure that record materials generated electronically are clearly identified as records and protected from unauthorized change or deletion for the length of their scheduled retention period; and

(9) Establish and implement procedures for the separate maintenance of any personal papers in accordance with § 1222.36.

(c) Agencies must ensure that:

(1) Records in their legal custody sent for off-site storage are maintained in facilities that meet the standards specified in 36 CFR part 1228, subpart K;

(2) The information requirements specified at 36 CFR 1228.154 are met; and

(3) They remove their records from any records storage facility that does not correct nonconformances with the standards specified in 36 CFR part 1228, subpart K. (A facility is compliant if it does not have to meet the standard until a specific date in the future or compliance has been waived by NARA in accordance with 36 CFR 1228.238.) Agencies must initiate removal of the records from such a center within 6 months of initial discovery of the deficiencies by NARA or the agency and to complete removal of the records within 18 months after initial discovery of the deficiencies.

[55 FR 27423, July 2, 1990, as amended at 60 FR 44640, Aug. 28, 1995; 64 FR 67664, Dec. 2, 1999]

## PART 1228—DISPOSITION OF FEDERAL RECORDS

Sec.

1228.1 Scope of part.

### Subpart A—Records Disposition Programs

1228.10 Authority.  
1228.12 Basic elements of disposition programs.

### Subpart B—Scheduling Records

1228.20 Authorities.  
1228.22 Developing records schedules.  
1228.24 Formulation of agency records schedules.  
1228.26 Request for records disposition authority.  
1228.28 Scheduling permanent records.  
1228.30 Scheduling temporary records.  
1228.32 Request to change disposition authority.

### Subpart C—General Records Schedules

1228.40 Authority.  
1228.42 Applicability.  
1228.44 Current schedules.  
1228.46 Availability.

### Subpart D—Implementing Schedules

1228.50 Application of schedules.  
1228.52 Withdrawal of disposal authority.  
1228.54 Temporary extension of retention periods.  
1228.56 Transfer of permanent records.  
1228.58 Destruction of temporary records.  
1228.60 Donation of temporary records.

### Subpart E—Loan of Permanent and Unscheduled Records

1228.70 Authority.  
1228.72 Approval.  
1228.74 Agency action.  
1228.76 NARA action on request.  
1228.78 Retrieval of records.

### Subpart F—Emergency Authorization to Destroy Records

1228.90 General provisions.  
1228.92 Menaces to human life or health or to property.  
1228.94 State of war or threatened war.

### Subpart G—Damage to, Alienation, and Unauthorized Destruction of Records

1228.100 Responsibilities.  
1228.102 Criminal penalties.  
1228.104 Reporting.  
1228.106 Exclusions.

### Subpart H—Transfer of Records From the Custody of One Executive Agency to Another

1228.120 Authority.  
1228.122 Approval.  
1228.124 Agency request.

**§ 1228.1**

- 1228.126 Agency concurrences.
- 1228.128 Records of terminated agencies.
- 1228.130 Equipment.
- 1228.132 Costs of transfers.
- 1228.134 Restrictions on use of records.
- 1228.136 Exceptions.

**Subpart I—Transfer of Records to Records Storage Facilities**

- 1228.150 Where can a Federal agency transfer records for storage?
- 1228.152 Under what conditions may Federal records be stored in records storage facilities?
- 1228.154 What requirements must an agency meet when it transfers records to a records storage facility?
- 1228.156 What procedures must an agency follow to transfer records to an agency records center or commercial records storage facility?

**Subpart J—Transfer, Use, and Disposition of Records in a NARA Records Center**

- 1228.160 How does an agency transfer records to a NARA records center?
- 1228.162 How does an agency transfer vital records to a NARA records center?
- 1228.164 What records must be transferred to the National Personnel Records Center (NPRC)?
- 1228.166 How does an agency transfer records to the National Personnel Records Center (NPRC)?
- 1228.168 How can records be used in NARA records centers?
- 1228.170 How are disposal clearances managed for records in NARA records centers?

**Subpart K—Facility Standards for Records Storage Facilities**

**GENERAL**

- 1228.220 What authority applies to this subpart?
- 1228.222 What does this subpart cover?
- 1228.224 Publications incorporated by reference.
- 1228.226 Definitions.

**FACILITY STANDARDS**

- 1228.228 What are the facility requirements for all records storage facilities?
- 1228.230 What are the fire safety requirements that apply to records storage facilities?
- 1228.232 What are the requirements for environmental controls for records storage facilities?

**36 CFR Ch. XII (7–1–03 Edition)**

**HANDLING DEVIATIONS FROM NARA'S FACILITY STANDARDS**

- 1228.234 What rules apply if there is a conflict between NARA standards and other regulatory standards that a facility must follow?
- 1228.236 How does an agency request a waiver from a requirement in this subpart?
- 1228.238 How does NARA process a waiver request?

**FACILITY APPROVAL AND INSPECTION REQUIREMENTS**

- 1228.240 How does an agency request authority to establish or relocate records storage facilities?
- 1228.242 What does an agency have to do to certify a fire-safety detection and suppression system?
- 1228.244 When may NARA conduct an inspection of a records storage facility?

**Subpart L—Transfer of Records to the National Archives of the United States**

- 1228.260 Authority.
- 1228.262 Types of records to be transferred.
- 1228.264 Certification for retention of records in agency custody.
- 1228.266 Audiovisual records.
- 1228.268 Cartographic and architectural records.
- 1228.270 Electronic records.
- 1228.272 Transfer of records to the National Archives of the United States.
- 1228.274 Restrictions on transferred records.
- 1228.276 Records subject to the Privacy Act of 1974.
- 1228.278 Release of equipment.
- 1228.280 Use of records transferred to the National Archives.
- 1228.282 Disposal clearances.

**APPENDIX A TO PART 1228—MINIMUM SECURITY STANDARDS FOR LEVEL III FEDERAL FACILITIES**

**APPENDIX B TO PART 1228—ALTERNATIVE CERTIFIED FIRE-SAFETY DETECTION AND SUPPRESSION SYSTEMS(S)**

**AUTHORITY:** 44 U.S.C. chs. 21, 29, and 33.

**SOURCE:** 45 FR 5705, Jan. 24, 1980. Redesignated at 50 FR 15723, Apr. 19, 1985, unless otherwise noted.

**§ 1228.1 Scope of part.**

This part sets policies and establishes standards, procedures, and techniques for the disposition of all Federal records in accordance with 44 U.S.C. chapters 21, 29, 31, and 33. The disposition of documentary materials created

or acquired by a Federal agency, regardless of physical form or characteristics, is controlled by this part if any of the following conditions are met:

(a) The materials are created or received in the course of business and contain information related to the organization, functions, policies, decisions, procedures, operations, or other official activities of the agency. Also included is documentation of oral exchanges such as telephone conversations and meetings during which policy was discussed or formulated or other significant activities of the agency were planned, discussed, or transacted.

(b) The creation, retention, or disposition of the materials is mandated by statute or agency or other Federal regulations, directives, policies, or procedures.

(c) The materials are controlled, maintained, preserved, processed, filed, or otherwise handled following established agency procedures for records.

(d) The material contains unique information, such as substantive annotations, including drafts, transmittal sheets, and final documents or other materials circulated or made available to employees other than the creator for official purposes, such as approval, comment, action, recommendation, follow-up, or to keep agency staff informed regarding agency business.

(e) The material was created or received on an electronic mail system and it meets the definition of record. For specific instructions on the disposition of records created or received on electronic mail systems, see 36 CFR 1234.32.

[55 FR 27428, July 2, 1990, as amended at 60 FR 44640, Aug. 28, 1995]

### Subpart A—Records Disposition Programs

#### § 1228.10 Authority.

The head of each agency (in accordance with 44 U.S.C. 2904, 3102, and 3301) is required to establish and maintain a records disposition program to ensure efficient, prompt, and orderly reduction in the quantity of records and to provide for the proper maintenance of

records designated as permanent by NARA.

[55 FR 27428, July 2, 1990]

#### § 1228.12 Basic elements of disposition programs.

The primary steps in managing a records disposition program are given below. Details of each element are contained in the NARA records management handbook, Disposition of Federal Records ([http://www.archives.gov/records\\_management/publications/disposition\\_of\\_federal\\_records/index.html](http://www.archives.gov/records_management/publications/disposition_of_federal_records/index.html)).

(a) Issue a program directive assigning authorities and responsibilities for records disposition activities in the agency and keep that directive up to date.

(b) Develop, implement, and maintain an accurate, current, and comprehensive records schedule.

(c) Train all agency personnel taking part in the agency's records disposition activities.

(d) Publicize the program to make all agency employees aware of their records disposition responsibilities.

(e) Evaluate the results of the program to ensure adequacy, effectiveness, and efficiency.

[55 FR 27428, July 2, 1990, as amended at 66 FR 27027, May 16, 2001; 67 FR 43253, June 27, 2002]

### Subpart B—Scheduling Records

SOURCE: 55 FR 27429, July 2, 1990, unless otherwise noted.

#### § 1228.20 Authorities.

(a) The head of each agency shall direct the creation and preservation of records containing accurate and complete documentation of the organization, functions, policies, decisions, procedures, and essential transactions of the agency (44 U.S.C. 3101). The National Archives and Records Administration shall establish standards for the retention of those records having continuing value, and assist Federal agencies in applying the standards to records in their custody (44 U.S.C. 2905).

(b) No Federal records shall be destroyed or otherwise alienated from

## § 1228.22

the Government except in accordance with procedures described in this part 1228 (44 U.S.C. 3314).

### § 1228.22 Developing records schedules.

The primary steps in developing agency records schedules are given below. Details in each step are contained in the NARA records management handbook, *Disposition of Federal Records* ([http://www.archives.gov/records\\_management/publications/disposition\\_of\\_federal\\_records/index.html](http://www.archives.gov/records_management/publications/disposition_of_federal_records/index.html)). Ultimately, all records of an agency must be scheduled, but they need not all be scheduled at the same time. An agency may schedule the records of one function, program or organizational element at a time.

(a) Determine the functions and activities documented by the records to be scheduled.

(b) Prepare an inventory of the records including a description of their medium, location, volume, inclusive dates, informational content and use.

(c) Evaluate the period of time the agency needs each records series or system by reference to its uses and value to agency operations or legal obligations.

(d) Based on agency need, develop specific recommended retention and disposition instructions for each records series or each part of an automated information system, including file breaks, retention periods for temporary records, transfer periods for permanent records, and instructions for the transfer of records to an approved records storage facility when appropriate.

(e) Assemble into a draft schedule the descriptions and recommended disposition instructions for logical blocks of records, i.e., entire agency, organizational component, or functional area.

(f) Obtain approval of the records schedules from NARA (and from the General Accounting Office, when so required under title 8 of the GAO "Policy and Procedures Manual for the Guidance of Federal Agencies").

[45 FR 5705, Jan. 24, 1980. Redesignated at 50 FR 15723, Apr. 19, 1985, as amended at 64 FR 67665, Dec. 2, 1999; 66 FR 27027, May 16, 2001; 67 FR 43253, June 27, 2002]

## 36 CFR Ch. XII (7-1-03 Edition)

### § 1228.24 Formulation of agency records schedules.

(a) *General.* Agency records schedules approved by the Archivist of the United States specify the disposition for agency records. Records of continuing (permanent) value will be scheduled for retention and immediate or eventual transfer to the legal custody of NARA. All other records will be scheduled for destruction or donation after a specific period of time based on administrative, fiscal, and legal values.

(b) *Characteristics of schedules.* Though records disposition authority may be requested from NARA on a program-by-program, function-by-function, or office-by-office basis, all agency records must be scheduled. Schedules must follow the guidelines provided below:

(1) Schedules shall identify and describe clearly each series or system and shall contain disposition instructions that can be readily applied. (Additional information is required for permanent records as specified in §1228.28(b).) Schedules must be prepared so that each office will have standing instructions detailing the disposal, transfer, or retention of records.

(2) SF 115s shall include only new records not covered by the General Records Schedules (GRS) (see subpart C), deviations from the GRS (see §1228.42), or previously scheduled records requiring changes in retention periods or substantive changes in description.

(3) All schedules shall take into account the physical organization of records or the filing system so that disposal or transfer can be handled in blocks.

(4) The disposition of nonrecord materials is controlled by instructions in the agency's printed or published records disposition manual. These instructions do not require NARA approval. Such items shall not be included on SF 115s. Non-record materials, such as extra copies of documents preserved solely for reference, and stocks of processed documents, and personal materials shall be maintained separately from official agency files to aid in records disposition.

(c) *Provisions of schedules.* Records schedules shall provide for:

(1) The destruction of records that have served their statutory, fiscal, or administrative uses and no longer have sufficient value to justify further retention. Procedures for obtaining disposal authorizations are prescribed in § 1228.30;

(2) The removal to a records storage facility of records not eligible for immediate destruction or other disposition but which are no longer needed in office space. These records are maintained by the records storage facility until they are eligible for final disposition action;

(3) The retention of the minimum volume of current records in office space consistent with effective and efficient operations; and

(4) The identification of records of permanent value in accordance with § 1228.28, and the establishment of cut-off periods and dates when such records will be transferred to the legal custody of NARA.

[45 FR 5705, Jan. 24, 1980. Redesignated at 50 FR 15723, Apr. 19, 1985, as amended at 64 FR 67665, Dec. 2, 1999]

**§ 1228.26 Request for records disposition authority.**

(a) *Submission.* Requests for records disposition authority shall be initiated by Federal agencies by submitting Standard Form 115, Request for Records Disposition Authority, to NARA (NWML). An SF 115 is used for requesting authority to schedule (or establish the disposition for) permanent and temporary records, either on a recurring or one-time basis.

(1) New Federal agencies shall apply General Records Schedules to eligible records and shall submit to NARA SF 115s covering all remaining records within 2 years of their establishment.

(2) Agencies shall submit to NARA schedules for the records of new programs and of programs that are reorganized or otherwise changed in a way that results in the creation of new or different records within 1 year of the implementation of the change.

(b) *Certification.* The signature of the authorized agency representative on the SF 115 shall constitute certification that the records recommended for disposal do not or will not have sufficient administrative, legal, or fiscal

value to the agency to warrant retention beyond the expiration of the specified period and that records described as having permanent value will be transferred to the National Archives upon expiration of the stated period.

(c) *Disapproval of requests for disposition authority.* Requests for records disposition authority may be returned to the agency if the SF 115 is improperly prepared. The agency shall make the necessary corrections and resubmit the form to NARA (NWML). NARA may disapprove the disposition request for an item if, after appraisal of the records, NARA determines that the proposed disposition is not consistent with the value of the records. In such cases, NARA will notify the agency in writing.

[55 FR 27429, July 2, 1990; 55 FR 28136, July 9, 1990, as amended at 63 FR 35829, July 1, 1998]

**§ 1228.28 Scheduling permanent records.**

(a) *Initiation.* Federal agencies propose permanent retention of records in accordance with guidelines contained in the NARA records management handbook, Disposition of Federal Records (<http://www.nara.gov/records/pubs/>).

(b) *Requirements.* Each item proposed for permanent retention on an SF 115 shall include the following:

(1) Records series title used by agency personnel to identify the records;

(2) Complete description of the records including physical type and information contents;

(3) Inclusive dates;

(4) An arrangement statement;

(5) Statement of restrictions on access which NARA should impose in conformity with the Freedom of Information Act if the records are proposed for immediate transfer;

(6) An estimate of the volume of records accumulated annually if the records are current and continuing;

(7) The total volume to date; and

(8) Disposition instructions, developed using the following guidelines:

(i) If the records series or system is current and continuing, the SF 115 will include a disposition instruction specifying the period of time after which the records will be transferred to the National Archives, normally within 30

§ 1228.30

36 CFR Ch. XII (7-1-03 Edition)

years for paper records, 5-10 years for audiovisual or microform records, and as soon as the records become inactive or the agency cannot meet the maintenance requirements found in §1228.270 of this part for electronic records.

(ii) If the records series or system is nonrecurring, i.e., no additional records will be created or acquired, the agency may propose either immediate or future transfer to the National Archives.

(c) *Determination.* NARA will determine whether or not records are of permanent value and when the transfer of the permanent records will take place.

(1) If NARA determines that records are not permanent, it will notify the agency and negotiate an appropriate disposition. The disposition instruction on the SF 115 will be modified prior to NARA approval.

(2) If NARA determines that records are permanent, but that the transfer instructions are not appropriate, it will negotiate appropriate transfer terms with the agency. The disposition instruction on the SF 115 will be modified prior to NARA approval.

[55 FR 27429, July 2, 1990; 55 FR 31982, Aug. 6, 1990, as amended at 66 FR 27027, May 16, 2001]

§ 1228.30 Scheduling temporary records.

(a) *Initiation.* Federal agencies request authority to dispose of records, either immediately or on a recurring basis. Requests for immediate disposal are limited to records already in existence which no longer accumulate. For recurring records, approved schedules provide continuing authority to destroy the records. The retention periods approved by NARA are mandatory, and the agency shall dispose of the records after expiration of the retention period, except as provided in §1228.54.

(b) *Requirements.* Each item on an SF 115 proposed for eventual destruction shall include the following:

(1) Records series title used by agency personnel to identify the records;

(2) Description of the records including physical type and informational content;

(3) If the records are contained in a Privacy Act system of records, a citation to the agency's alpha-numeric or

numeric code designation for the system of records. If the system of records was added or deleted since the publication of the current Office of the Federal Register compilation of Privacy Act Issuances, the agency shall also cite the date and page of the FEDERAL REGISTER on which the new system notice appears or the deleted system is announced.

(4) Disposition instructions, developed using the following guidelines:

(i) If the records series or system is current and continuing, the SF 115 will include a disposition instruction specifying the period of time after which the records will be destroyed.

(ii) If the records series or system is nonrecurring, i.e., no additional records will be created or acquired, the agency may propose either immediate destruction or destruction on a future date.

(c) *Determination.* NARA may determine that records proposed as temporary merit permanent retention and transfer to the National Archives. In such cases, NARA arranges with the agency to change the disposition instruction prior to approval of the SF 115.

(d) *General Accounting Office concurrence.* Each Federal agency shall obtain the approval of the Comptroller General for the disposal of program records less than 3 years old and for certain classes of records relating to claims and demands by or against the Government, and to accounts in which the Government is concerned in accordance with the GAO "Policy and Procedures Manual for Guidance of Federal Agencies," title 8—Records Management (44 U.S.C. 3309). This approval must be obtained before the approval of the disposal request by NARA, but the request may be submitted concurrently to GAO and NARA.

(e) *Withdrawn items.* Agencies may request that items listed on the SF 115 be withdrawn in order to aid in NARA's processing (appraisal) of the remaining items on the schedule.

(1) If, during the course of the appraisal process, NARA determines that records described by an item(s) on the proposed schedule do not exist or are not arranged as stated on the SF 115,



NARA may request the agency to withdraw the item(s) from consideration, if the agency is unable to offer sufficient clarification.

(2) If NARA and the agency cannot agree on the retention period for an item(s), the item(s) may be withdrawn. In these cases, the agency will submit an SF 115 with a revised proposal for disposition within 6 months of the date of the approval of the original SF 115.

[55 FR 27429, July 2, 1990, as amended at 57 FR 22432, May 28, 1992]

**§ 1228.32 Request to change disposition authority.**

(a) Agencies desiring to change the approved retention period of a series or system of records shall submit an SF 115. Disposition authorities contained in an approved SF 115 are automatically superseded by approval of a later SF 115 applicable to the same records unless the later SF 115 specified an effective date. Agencies submitting revised schedules shall indicate on the SF 115 the relevant schedule and item numbers to be superseded, the citation to the current printed records disposition schedule, if any, and/or the General Records Schedules and item numbers that cover the records.

(b) Agencies proposing to change the retention period of a series or system of records shall submit with the SF 115 an explanation and justification for the change. The need to retain records longer than the retention period specified in the disposition instructions on an approved SF 115 for purposes of audit, court order, investigation, litigation, study, or any other administrative purpose that justifies the temporary extension of the retention period shall be governed by the procedures set forth in §1228.54. Agencies shall not submit an SF 115 to change the retention period in such cases.

(c) Agencies must secure NARA approval before changing the provision in a disposition instruction that specifies the period of time that permanent records will remain in agency legal custody prior to transfer to the National Archives of the United States.

[61 FR 19554, May 2, 1996; 61 FR 24702, May 16, 1996, as amended at 64 FR 67665, Dec. 2, 1999]

**Subpart C—General Records Schedules**

SOURCE: 55 FR 27430, July 2, 1990, unless otherwise noted.

**§ 1228.40 Authority.**

The Archivist of the United States issues schedules authorizing disposal, after specified periods of time, of temporary records common to several or all agencies of the U.S. Government. General Records Schedules authorize the destruction of records after the stated retention period expires. Application of the disposition instructions in these schedules is mandatory (44 U.S.C. 3303a), provided an agency has not already received disposition authority from NARA.

[67 FR 31962, May 13, 2002]

**§ 1228.42 Applicability.**

(a) Agencies must apply GRS authorizations except as provided in paragraphs (b) or (c) of this section. Agencies must not include on SFs 115 records covered by the GRS unless a different retention period is requested, as specified in paragraph (c) of this section.

(b) Agencies may apply either the disposition instructions in a new or revised GRS or the disposition instructions previously approved by NARA in an agency schedule for the same series or system of records, unless NARA indicates that the new GRS disposition instruction must be applied without exception. The authority chosen by the agency must be applied on an agency-wide basis. The agency must notify NARA within 90 days of the date of the GRS change if it intends to continue using the agency schedule.

(c) Except as provided in paragraph (b) of this section, agencies that wish a different retention period must request an exception to the GRS by submitting an SF 115 in accordance with §1228.30 accompanied by a written justification for the different retention period.

(d) Provisions of the General Records Schedules may be applied to records in the custody of the National Archives at

## § 1228.44

NARA's discretion subject to the provisions of § 1228.282.

[55 FR 27430, July 2, 1990, as amended at 67 FR 31962, May 13, 2002; 67 FR 47701, July 22, 2002]

### § 1228.44 Current schedules.

The following General Records Schedules governing the disposition of records common to several or all agencies were developed by the National Archives and Records Administration after consultation with other appropriate agencies. They have been approved by the Archivist of the United States.

#### SCHEDULE NUMBER AND TYPE OF RECORDS GOVERNED

1. Civilian Personnel Records.
2. Payrolling and Pay Administration Records.
3. Procurement, Supply and Grant Records.
4. Property Disposal Records.
5. Budget Preparation, Presentation, and Apportionment Records.
6. Accountable Officers' Accounts Records.
7. Expenditure Accounting Records.
8. Stores, Plant, and Cost Accounting Records.
9. Travel and Transportation Records.
10. Motor Vehicle Maintenance and Operation Records.
11. Space and Maintenance Records.
12. Communications Records.
13. Printing, Binding, Duplication, and Distribution Records.
14. Information Services Records.
15. Housing Records.
16. Administrative Management Records.
17. Cartographic, Aerial Photographic, Architectural, and Engineering Records.
18. Security and Protective Services Records.
19. RESERVED.
20. Electronic Records.
21. Audiovisual Records.
22. Inspector General Records (WITHDRAWN).
23. Records Common to Most Offices Within Agencies.

[55 FR 27430, July 2, 1990, as amended at 66 FR 27027, May 16, 2001]

### § 1228.46 Availability.

The GRS and instructions for their use are available from NARA (NWM). The Archivist of the United States distributes new schedules and schedule re-

## 36 CFR Ch. XII (7-1-03 Edition)

visions under sequentially numbered GRS transmittals.

[55 FR 27430, July 2, 1990, as amended at 63 FR 35829, July 1, 1998]

## Subpart D—Implementing Schedules

SOURCE: 55 FR 27431, July 2, 1990, unless otherwise noted.

### § 1228.50 Application of schedules.

The application of approved schedules is mandatory (44 U.S.C. 3303a). The Archivist of the United States will determine whether or not records may be destroyed or transferred to the National Archives. If the Archivist approves the request for disposition authority, NARA will notify the agency by returning one copy of the completed SF 115. This shall constitute mandatory authority for the final disposition of the records (for withdrawal of disposal authority or the extension of retention periods, see §§ 1228.52 and 1228.54). The authorized destruction shall be accomplished as prescribed in § 1228.58. The head of each Federal agency shall direct the application of records schedules to ensure the agency maintains recorded information necessary to conduct Government business, avoid waste, and preserve permanent records for transfer to the National Archives. The agency head shall take the following steps to ensure proper dissemination and application of approved schedules:

(a) Issue an agency directive incorporating the disposition authorities approved by NARA, i.e., SF 115s (except for one-time authorities covering non-recurring records) and the General Records Schedules. Also include non-record materials with disposition instructions developed by the agency. Once all records and nonrecord materials are included, this document is the agency's comprehensive schedule. Agencies may also issue other directives containing instructions relating to agency records disposition procedures.

(1) Published schedules contain disposition authorities granted by NARA for records that the agency continues

to create. They include general instructions for transfer of records to a records storage facility, transfer of records to the National Archives of the United States, and other retention and disposition procedures. They do not include nonrecurring records for which NARA has granted authority for immediate disposal or transfer to the National Archives of the United States.

(2) Comprehensive schedules are formally published manuals or directives that provide for the disposition of all recurring records and nonrecord materials created by an agency. These schedules must cite the GRS or SF 115 and item numbers that provide the legal disposition authority for items covering record material.

(3) Prior to issuance, agencies may consult with NARA concerning directives or other issuances containing approved schedules, instructions for use of NARA records centers, transfer of records to the National Archives of the United States, or other matters covered by NARA procedures or regulations.

(4) Agencies must submit to the National Archives and Records Administration (NWML) copies of published records schedules and all directives and other issuances relating to records disposition, within 30 days of implementation or internal dissemination, as specified below. If an agency both prints copies for distribution and posts an electronic copy, it should follow the instructions in paragraph (a)(4)(ii) of this section.

(i) Agencies that print these materials for internal distribution must forward to NARA (NWML), 8601 Adelphi Rd., College Park, MD 20740-6001, three copies of each final directive or other issuance relating to records disposition and 20 copies of all published records schedules (printed agency manuals) and changes to all manuals as they are issued.

(ii) Agencies that make these materials available via the Internet or internally on an Intranet web site or by other electronic means must submit one printed or electronic copy, in a format specified by NARA, to NARA (NWML) when the directive or manual is posted or distributed. Electronic mail messages transmitting copies of

agency schedules as electronic attachments may be sent to *records.mgt@nara.gov*. These submissions must specify the name, title, agency, address, and telephone number of the submitter. If the records schedule is posted on a publicly available web site, the agency must also provide the Internet address (URL).

(b) Establish internal training programs to acquaint appropriate personnel with the requirements and procedures of the records disposition program.

(c) Apply the approved records disposition schedules to the agency's records.

(1) Records described by items marked "disposition not approved" or "withdrawn" may not be destroyed until a specific disposition has been approved by NARA.

(2) Disposition authorities for items on approved SF 115s that specify an organizational component of the department or independent agency as the creator or custodian of the records may be applied to the same records after internal reorganization, but only if the nature, content, and functional importance of the records remain the same. Authority approved for items described in a functional format may be applied to any organizational component within the department or independent agency that is responsible for the relevant function.

(3) Disposition authorities approved for one department or independent agency may not be applied by another. Departments or agencies that acquire records from another department or agency, and/or continue creating the same series of records previously created by another department or agency through interagency reorganization must submit an SF 115 to NARA for disposition authorization for the records within one year of the reorganization.

(4) Unless otherwise specified, disposition authorities apply retroactively to all existing records as described in the schedule, including records acquired by transfer of function within or between agencies, as long as the nature, content, and functional importance of the records series is unchanged.

## § 1228.52

(d) Review approved schedules, and, if necessary, update them annually. Additions and changes to the GRS shall be incorporated or otherwise disseminated within 6 months of issuance from NARA.

[55 FR 27431, July 2, 1990, as amended at 63 FR 35829, July 1, 1998; 64 FR 67665, Dec. 2, 1999; 67 FR 31963, May 13, 2002]

### § 1228.52 Withdrawal of disposal authority.

In an emergency or in the interest of efficiency of Government operations, NARA will withdraw disposal authorizations in approved disposal schedules (44 U.S.C. 2909). This withdrawal may apply to particular items on schedules submitted by agencies or may apply to all existing authorizations for the disposal of a specified type of record obtained by any or all agencies of the Government. If the withdrawal is applicable to only one agency, that agency will be notified of this action by letter signed by the Archivist; if applicable to more than one agency, notification may be by NARA bulletin issued and signed by the Archivist.

### § 1228.54 Temporary extension of retention periods.

(a) Approved agency records schedules and the General Records Schedules are mandatory (44 U.S.C. 3303a). Records series or systems eligible for destruction must not be maintained longer without the prior written approval of the National Archives and Records Administration (NWML) except when:

(1) The agency has requested a change in the retention period for the records series or system in accordance with § 1228.32; or

(2) Records are needed for up to one year beyond the date they are eligible for disposal. When such records are in a records storage facility, the agency must notify the facility of the need for continued retention of the records.

(b) Upon submission of adequate justification, NARA may authorize a Federal agency to extend the retention period of a series or system of records (44 U.S.C. 2909). These extensions of retention periods will be granted for records which are required to conduct Government operations because of special cir-

## 36 CFR Ch. XII (7-1-03 Edition)

cumstances which alter the normal administrative, legal, or fiscal value of the records.

(c) The head of a Federal agency may request approval of a temporary extension of a retention period by sending a letter to NARA (NWML), 8601 Adelphi Rd., College Park, MD 20740-6001. The request shall include:

(1) A concise description of the records series for which the extension is requested.

(2) A complete citation of the specific provisions of the agency records schedule or the General Records Schedule currently governing disposition of the records;

(3) A statement of the estimated period of time that the records will be required; and

(4) A statement of the current and proposed physical location of the records.

(d) Approval of a request for extension of retention periods may apply to records in the custody of one Federal agency or records common to several or all Federal agencies. If approval of a request is applicable to records in the custody of one agency, that agency will be notified by letter. If approval is applicable to records common to several agencies, notification may be made by NARA bulletin.

(e) Agencies must ensure that affected records storage facilities are notified when NARA approves an extension of the retention period beyond the period authorized in the records control schedule. Agencies must forward to NARA (NWML) two copies of all formally issued instructions which extend the retention periods.

(f) Upon expiration of an approved extension of retention period, NARA will notify all affected agencies to apply normal retention requirements.

[55 FR 27431, July 2, 1990, as amended at 61 FR 19554, May 2, 1996; 61 FR 24702, May 16, 1996; 63 FR 35829, July 1, 1998; 64 FR 67665, Dec. 2, 1999]

### § 1228.56 Transfer of permanent records.

All records scheduled as permanent shall be transferred to the National Archives after the period specified on the SF 115 in accordance with procedures specified under subpart J.

## National Archives and Records Administration

## § 1228.60

### § 1228.58 Destruction of temporary records.

(a) *Authority.* Federal agencies are required to follow regulations issued by the Archivist of the United States governing the methods of destroying records (44 U.S.C. 3302). Only the methods described in this section shall be used.

(b) *Sale or salvage.* Paper records to be disposed of normally must be sold as wastepaper. If the records are restricted because they are national security classified or exempted from disclosure by statute, including the Privacy Act, or regulation, the wastepaper contractor must be required to pulp, macerate, shred, or otherwise definitively destroy the information contained in the records, and their destruction must be witnessed either by a Federal employee or, if authorized by the agency that created the records, by a contractor employee. The contract for sale must prohibit the resale of all other paper records for use as records or documents. Records other than paper records (audio, visual, and data tapes, disks, and diskettes) may be salvaged and sold in the same manner and under the same conditions as paper records. All sales must be in accordance with the established procedures for the sale of surplus personal property. (See 41 CFR part 101-45, Sale, Abandonment, or Destruction of Personal Property.)

(c) *Destruction.* If the records cannot be sold advantageously or otherwise salvaged, the records may be destroyed by burning, pulping, shredding, macerating, or other suitable means.

### § 1228.60 Donation of temporary records.

(a) When the public interest will be served, a Federal agency may propose the transfer of records eligible for disposal to an appropriate person, organization, institution, corporation, or government (including a foreign government) that has requested them. Records will not be transferred without prior written approval of NARA.

(b) The head of a Federal agency shall request the approval of such a transfer by sending a letter to NARA (NWML), 8601 Adelphi Rd., College

Park, MD 20740-6001. The request shall include:

(1) The name of the department or agency, and subdivisions thereof, having custody of the records;

(2) The name and address of the proposed recipient of the records;

(3) A list containing:

(i) An identification by series or system of the records to be transferred,

(ii) The inclusive dates of the records,

(iii) The NARA disposition of job (SF 115) or GRS and item numbers that authorize disposal of the records;

(4) A statement providing evidence:

(i) That the proposed transfer is in the best interests of the Government,

(ii) That the proposed recipient agrees not to sell the records as records or documents, and

(iii) That the transfer will be made without cost to the U.S. Government;

(5) A certification that:

(i) The records contain no information the disclosure of which is prohibited by law or contrary to the public interest, and/or

(ii) That records proposed for transfer to a person or commercial business are directly pertinent to the custody or operations of properties acquired from the Government, and/or

(iii) That a foreign government desiring the records has an official interest in them.

(c) NARA will consider such request and determine whether the donation is in the public interest. Upon approval NARA will notify the requesting agency in writing. If NARA determines such a proposed donation is contrary to the public interest, the request will be denied and the agency will be notified that the records must be destroyed in accordance with the appropriate disposal authority.

[55 FR 27431, July 2, 1990, as amended at 63 FR 35829, July 1, 1998]

### Subpart E—Loan of Permanent and Unscheduled Records

SOURCE: 55 FR 27433, July 2, 1990, unless otherwise noted.

## § 1228.70

### § 1228.70 Authority.

The Archivist of the United States has authority over the placement of permanent records (44 U.S.C. 2107 and 2904). As unscheduled records have not been appraised, they will be deemed permanent for the purposes of this section and are also covered by this authority.

### § 1228.72 Approval.

No permanent or unscheduled records shall be loaned to non-Federal recipients without prior written approval from NARA. This authorization is not required for temporary loan of permanent and unscheduled records between Federal agencies.

### § 1228.74 Agency action.

(a) An agency proposing to loan permanent or unscheduled records shall execute a written loan agreement with the proposed recipient. The agreement shall include:

(1) The name of the department or agency and subdivisions thereof having custody of the records;

(2) The name and address of the proposed recipient of the records;

(3) A list containing:

(i) An identification by series or system of the records to be loaned,

(ii) The inclusive dates for each series,

(iii) The volume and media of the records to be loaned, and

(iv) The NARA disposition job (SF 115) and item numbers covering the records, if any;

(4) A statement of the purpose and duration of the loan;

(5) A statement specifying any restrictions on the use of the records and how these restrictions will be administered by the donee; and

(6) A certification that the records will be stored according to the environmental specifications for archival records.

(b) The Archivist of the United States shall be a signatory on all loan agreements for permanent and unscheduled records. An agreement may not be implemented until the Archivist has signed.

(c) The head of the Federal agency shall request approval for the loan by sending a letter to NARA (NWML), 8601

## 36 CFR Ch. XII (7-1-03 Edition)

Adelphi Rd., College Park, MD 20740-6001, transmitting the proposed loan agreement and specifying the name, title, and telephone number of the person NARA should contact about the proposed loan.

[57 FR 22432, May 28, 1992, as amended at 63 FR 35829, July 1, 1998]

### § 1228.76 NARA action on request.

NARA will review the request and, if found acceptable, return the approved agreement to the agency. NARA will deny the request if the records should be transferred to the National Archives in accordance with subpart J of this part or if the loan would endanger the records or otherwise contravene the regulations in 36 CFR chapter XII, subchapter B. If NARA disapproves the loan, the Archivist will notify the agency in writing and provide instructions for the disposition of the records.

[57 FR 22432, May 28, 1992; 57 FR 24308, June 8, 1992]

### § 1228.78 Retrieval of records.

An agency shall contact the recipient of the loan of permanent or unscheduled records 30 days prior to the expiration of the loan period (as stated in the loan agreement) to arrange for the return of the records. If the agency extends the duration of the loan, it shall notify NARA (NWML) in writing, specifying the reason for the extension and providing a new time limit for the loan.

[57 FR 22432, May 28, 1992, as amended at 63 FR 35829, July 1, 1998]

## Subpart F—Emergency Authorization to Destroy Records

### § 1228.90 General provisions.

Under certain conditions, records may be destroyed without regard to the provisions of subpart D.

[45 FR 5705, Jan. 24, 1980. Redesignated at 50 FR 15723, Apr. 19, 1985, and 55 FR 27433, July 2, 1990]

### § 1228.92 Menaces to human life or health or to property.

(a) Agencies may destroy records that constitute a continuing menace to human health or life or to property (44

U.S.C. 3310). When such records are identified, the agency head shall notify NARA (NWML), specifying the nature of the records, their location and quantity, and the nature of the menace. If NARA concurs in the determination, the Archivist will direct the immediate destruction of the records or other appropriate means of destroying the recorded information. However, if the records are still or motion picture film on nitrocellulose base that has deteriorated to the extent described in paragraph (b) of this section, the head of the agency may follow the procedure therein provided.

(b) Whenever any radarscope, aerial, or other still or motion picture film on nitrocellulose base has deteriorated to the extent that it is soft and sticky, is emitting a noxious order, contains gas bubbles, or has retrograded into acrid powder, and the head of the agency having custody of it shall determine that it constitutes a menace to human health or life or to property, then the agency shall without prior authorization of the Archivist:

(1) Arrange for its destruction in a manner that will salvage its silver content if the silver content is of sufficient quantity and market value per troy ounce to warrant such salvage;

(2) Authorize burial in approved landfills, in the event the quantity is not sufficiently large to justify the salvaging of its silver content; or

(3) Effect other appropriate methods in the event that the methods provided in paragraph (b)(1) or (2) of this section are not feasible.

(c) These films should be removed from inhabited buildings as soon as possible.

(d) Within 30 days after the destruction of the film as provided in this section, the head of the agency who directed its destruction shall submit a written statement to NARA (NWML), 8601 Adelphi Rd., College Park, MD 20740-6001, describing the film and showing when, where, and how the destruction was accomplished.

(e) This report has been cleared in accordance with GSA regulations in Title

41 of the CFR and assigned Interagency Report Control Number 1095-NAR-AR.

[45 FR 5705, Jan. 24, 1980. Redesignated and amended at 50 FR 15723, 15725, Apr. 19, 1985; 51 FR 23538, June 30, 1986. Redesignated and amended at 55 FR 27433, July 2, 1990; 63 FR 35829, July 1, 1998; 66 FR 27027, May 16, 2001]

#### § 1228.94 State of war or threatened war.

(a) Destruction of records outside the territorial limits of the continental United States is authorized whenever, during a state of war between the United States and any other nation or when hostile action by a foreign power appears imminent, the head of the agency that has custody of the records determines that their retention would be prejudicial to the interest of the United States, or that they occupy space urgently needed for military purposes and are without sufficient administrative, legal, research, or other value to warrant their continued preservation (44 U.S.C. 3311).

(b) Within 6 months after the destruction of any records under this authorization, a written statement describing the character of the records and showing when and where the disposal was accomplished shall be submitted to NARA (NWML) by the agency official who directed the disposal.

[55 FR 27433, July 2, 1990, as amended at 63 FR 35829, July 1, 1998]

### Subpart G—Damage to, Alienation, and Unauthorized Destruction of Records

#### § 1228.100 Responsibilities.

(a) The Archivist of the United States and heads of Federal agencies are responsible for preventing the alienation or unauthorized destruction of records, including all forms of mutilation. Records may not be removed from the legal custody of Federal agencies or destroyed without regard to the provisions of agency records schedules (SF 115 approved by NARA or the General Records issued by NARA).

(b) The heads of Federal agencies are responsible for ensuring that all employees are aware of the provisions of

## § 1228.102

the law relating to unauthorized destruction, alienation, or mutilation of records, and should direct that any such action be reported to them.

[55 FR 27433, July 2, 1990, as amended at 64 FR 67665, Dec. 2, 1999]

### § 1228.102 Criminal penalties.

The maximum penalty for the willful and unlawful destruction, damage, or alienation of Federal records is a \$2,000 fine, 3 years in prison, or both (18 U.S.C. 2071).

[55 FR 27434, July 2, 1990]

### § 1228.104 Reporting.

(a) The head of a Federal agency shall report any unlawful or accidental destruction, defacing, alteration, or removal of records in the custody of that agency to NARA (NWML), 8601 Adelphi Rd., College Park, MD 20740-6001. The report shall include:

(1) A complete description of the records with volume and dates if known;

(2) The office of origin;

(3) A statement of the exact circumstances surrounding the alienation, defacing, or destruction of the records;

(4) A statement of the safeguards established to prevent further loss of documentation; and

(5) When appropriate, details of the actions taken to salvage, retrieve, or reconstruct the records.

(b) This report has been cleared in accordance with GSA regulations in Title 41 of the CFR and assigned Interagency Report Control Number 0285-NAR-AR.

(c) The Archivist of the United States will assist the head of the agency in contacting the Attorney General for the recovery of any unlawfully removed records.

[45 FR 5705, Jan. 24, 1980, as amended at 46 FR 60205, Dec. 9, 1981. Redesignated and amended at 50 FR 15723, 15725, Apr. 19, 1985; 51 FR 23538, June 30, 1986. Redesignated and amended at 55 FR 27434, July 2, 1990; 63 FR 35829, July 1, 1998; 66 FR 27027, May 16, 2001]

### § 1228.106 Exclusions.

Private or personal files are not governed by these provisions. 36 CFR 1222.36 provides the legal definition of

## 36 CFR Ch. XII (7-1-03 Edition)

personal papers and prescribes standards for their maintenance.

[45 FR 5705, Jan. 24, 1980. Redesignated and amended at 50 FR 15723, 15725, Apr. 19, 1985. Further redesignated at 55 FR 27433, July 2, 1990; 66 FR 27027, May 16, 2001]

## Subpart H—Transfer of Records from the Custody of One Executive Agency to Another

SOURCE: 45 FR 5705, Jan. 24, 1980, unless otherwise noted. Redesignated at 50 FR 15723, Apr. 19, 1985, and 55 FR 27433, July 2, 1990.

### § 1228.120 Authority.

The Archivist of the United States will issue regulations governing the transfer of records from the custody of one executive agency to another (44 U.S.C. 2908).

### § 1228.122 Approval.

No records shall be transferred from the custody of one executive agency to another without the prior written approval of the National Archives and Records Administration except as provided in § 1228.136.

### § 1228.124 Agency request.

The head of any executive agency may request the transfer of records to or from his or her agency. Approval shall be requested by letter addressed to the NARA (NWML), in which are included:

(a) A concise description of the records to be transferred, including the volume in cubic feet;

(b) A statement of the restrictions imposed on the use of records;

(c) A statement of the agencies and persons using the records and the purpose of this use;

(d) A statement of the current and proposed physical and organizational locations of the records; and

(e) A justification for the transfer including an explanation of why it is in the best interests of the Government.

[45 FR 5705, Jan. 24, 1980. Redesignated at 50 FR 15723, Apr. 19, 1985, and amended at 50 FR 26934, June 28, 1985. Redesignated and amended at 55 FR 27434, July 2, 1990; 63 FR 35829, July 1, 1998]



**§ 1228.126 Agency concurrences.**

Copies of the concurrence or non-concurrence in the transfer by the heads of any agencies concerned shall be attached to the agency request.

**§ 1228.128 Records of terminated agencies.**

Transfers of records of executive agencies whose functions are terminated or are in process of liquidation are expressly subject to this part 1228 and no such transfers shall be made except in accordance with its provisions.

**§ 1228.130 Equipment.**

Records storage equipment shall be transferred with the records contained therein in accordance with arrangements previously agreed to by the agencies concerned.

**§ 1228.132 Costs of transfers.**

Approved transfers shall be made without reimbursement to the agency of original custody for any cost involved, except when this reimbursement is previously agreed to by the agencies concerned.

**§ 1228.134 Restrictions on use of records.**

Whenever any records that are transferred are subject to restrictions upon their use imposed under a statute, Executive order, or agency determination, these restrictions shall continue in effect after the transfer. Restrictions imposed by agency determination may be removed by agreement between the agencies concerned.

**§ 1228.136 Exceptions.**

Prior written approval of NARA is not required when:

- (a) Records are transferred to Federal records centers or the National Archives in accordance with subparts I and J.
- (b) Records are loaned for official use.
- (c) The transfer of records or functions or both is required by statute, Executive Order, Presidential reorganization plan, or Treaty, or by specific determinations made thereunder.

(d) The records are transferred between two components of the same Executive department.

(e) Records accessioned by the National Archives, later found to lack sufficient value for continued retention by the National Archives are governed exclusively for further disposition in accordance with § 1228.200.

[55 FR 27434, July 2, 1990]

### Subpart I—Transfer of Records to Records Storage Facilities

SOURCE: 64 FR 67665, Dec. 2, 1999, unless otherwise noted.

**§ 1228.150 Where can a Federal agency transfer records for storage?**

Federal agencies may store records in the following types of records storage facilities, so long as the facilities meet the facility standards in subpart K of this part. Records transferred to a records storage facility remain in the legal custody of the agency.

(a) NARA records centers. NARA owns or operates records centers for the storage, processing, and servicing of records for Federal agencies under the authority of 44 U.S.C. 2907. These NARA records centers include a National Personnel Records Center which contains designated records of the Department of Defense and the Office of Personnel Management and other designated records pertaining to former Federal civilian employees. A list of NARA records centers is available from the NARA web site at <http://www.archives.gov/facilities/index.html> and also in the U.S. Government Manual, which is for sale from the Superintendent of Documents, U.S. Government Printing Office, Mail Stop: SSOP, Washington, DC 20402-9328, and is available on the Internet from <http://www.access.gpo.gov/nara>.

(b) Records centers operated by or on behalf of one or more Federal agencies other than NARA.

(c) Commercial records storage facilities operated by private entities.

[64 FR 67665, Dec. 2, 1999, as amended at 67 FR 43253, June 27, 2002]

**§ 1228.152**

**36 CFR Ch. XII (7-1-03 Edition)**

**§ 1228.152 Under what conditions may Federal records be stored in records storage facilities?**

age facility and the conditions that apply:

The following chart shows what records can be stored in a records stor-

Type of Record	Conditions
(1) Permanent records .....	(i) Any storage facility that meets the provisions of subpart K of this part.
(2) Unscheduled records .....	(i) Any storage facility that meets the provisions of subpart K of this part. (ii) Also requires submission of SF 115 and its acceptance from NARA under the provisions of subpart B of this part.
(3) Temporary records (excluding Civilian Personnel Records).	(i) Any storage facility that meets the provisions of subpart K of this part.
(4) Vital records .....	(i) Storage facility must meet the provisions of subpart K of this part and 36 CFR part 1236.
(5) Civilian Personnel Records .....	(i) May only be transferred to NPRC, St. Louis as required by this part.

**§ 1228.154 What requirements must an agency meet when it transfers records to a records storage facility?**

scription must include a folder title list of the box contents or equivalent detailed records description);

An agency must meet the following requirements when it transfers records to a records storage facility:

- (iv) Date span;
- (v) Physical form and medium of records (e.g., paper, motion picture film, sound recordings, photographs or digital images);
- (vi) Volume;
- (vii) Citation to NARA-approved schedule or agency records disposition manual (unscheduled records must cite the date the SF 115 was submitted to NARA);
- (viii) Restrictions on access if applicable;
- (ix) Disposition (“permanent,” “temporary,” or “unscheduled; SF 115 pending”);
- (x) Date of disposition action (transfer to the National Archives of the United States or destruction);
- (xi) Physical location, including name and address of facility; and
- (xii) Control number or identifier used to track records.

(a) Ensure that the requirements of subpart K of this part are met. Special attention must be paid to ensuring appropriate storage conditions for records on non-paper based media (e.g., film, audio tape, magnetic tape), especially those that are scheduled for long-term or permanent retention, as those records typically require more stringent environmental controls (see 36 CFR parts 1230 through 1234).

(b) To transfer unscheduled records, submit an SF 115 to NARA (NWML) prior to the transfer. The agency may transfer the records only after NARA has determined that the SF 115 meets the requirements specified in this part.

(c) Create documentation sufficient to identify and locate files.

(1) Such documentation must include for each individual records series spanning one or more consecutive years transferred to storage:

- (i) Creating office;
- (ii) Series title;
- (iii) Description (in the case of permanent or unscheduled records, the de-

(2) In the case of permanent and unscheduled records, provide copies of such documentation to NARA and advise NARA in writing of the new location whenever the records are moved to a new storage facility.

(d) Ensure that NARA-approved retention periods are implemented properly and that records documenting final disposition actions (destruction or transfer to the National Archives of the United States) are created and maintained as required by 36 CFR 1220.36.

(1) Retain temporary records until the expiration of their NARA-approved retention period and no longer, except as provided for in § 1228.54.

(2) Transfer permanent records to the National Archives of the United States in accordance with § 1228.260.

(e) Provide access to appropriate NARA staff to records wherever they are located in order to conduct an evaluation in accordance with 36 CFR 1220.50 or to process a request for records disposition authority.

(f) Move temporary records that are subsequently reappraised as permanent to a facility that meets the environmental control requirements for permanent records in § 1228.232 within one year of their re-appraisal, if not already in such a facility. (Paper-based permanent records in an existing records storage facility that does not meet the environmental control requirements in § 1228.232(b) on October 1, 2009, must be moved from that facility no later than February 28, 2010.)

**§ 1228.156 What procedures must an agency follow to transfer records to an agency records center or commercial records storage facility?**

Federal agencies must use the following procedures to transfer records to an agency records center or commercial records storage facility:

(a) Agreements with agency records centers or contracts with commercial records storage facilities must incorporate the standards in subpart K of this part and allow for inspections by the agency and NARA to ensure compliance. An agency must remove records promptly from a facility if deficiencies identified during an inspection are not corrected within six months.

(b) For temporary records, the agency must make available to NARA on request the documentation specified in § 1228.154. For permanent records, the agency must transmit this documenta-

tion to NARA (NWML) no later than 30 days after records are transferred to the agency records center or commercial records storage facility. For unscheduled records, the agency must transmit the information to NWML with the SF 115 before the records are transferred as required by § 1228.154(b).

(c) Agencies must establish procedures that ensure that temporary records are destroyed in accordance with NARA-approved schedules and that NARA-approved changes to schedules, including the General Records Schedules, are applied to records in agency records centers or commercial records storage facilities in a timely fashion. Procedures must include a requirement that the agency records center or commercial records storage facility notify agency records managers or the creating office prior to the disposal of temporary records unless disposal of temporary records is initiated by the agency.

(d) Agencies must establish procedures to ensure that the agency records centers or commercial records storage facilities transfer permanent records to the National Archives of the United States as individual series spanning one or more years and in accordance with the provisions of § 1228.272.

(e) Agencies must ensure that records that are restricted because they are security classified or exempt from disclosure by statute, including the Privacy Act (5 U.S.C. 552a), or regulation are stored and maintained in accordance with applicable laws, executive orders, or regulations.

(f) Agencies must ensure that disposable records, including restricted records (security classified or exempted from disclosure by statute, including the Privacy Act, or regulation), are destroyed in accordance with the requirements specified in § 1228.58.

(g) Agencies must ensure that emergency operating vital records, as defined in 36 CFR 1236.14, that are transferred to an agency records center or commercial records storage facility are available in accordance with 36 CFR part 1236.

### Subpart J—Transfer, Use, and Disposition of Records in a NARA Records Center

SOURCE: 64 FR 67667, Dec. 2, 1999, unless otherwise noted.

#### § 1228.160 How does an agency transfer records to a NARA records center?

An agency transfers records to a NARA records center using the following procedures:

(a) *General.* NARA will ensure that its records centers meet the facilities standards in subpart K of this part, which meets the agency's obligation in § 1228.154(a).

(b) NARA records centers will not accept records that pose a threat to other records or to the health and safety of users including hazardous materials such as nitrate film, radioactive or chemically contaminated records, records exhibiting active mold growth, or untreated insect or rodent infiltrated records. Agencies may contact the NARA records center for technical advice on treating such records.

(c) Agencies may use any NARA records center (see § 1228.154(a)) if space is available for the storage of unclassified records. All NARA facilities are equipped to store classified records that have a national security classification up to Confidential, and certain NARA facilities can also accept Secret (or "Q") classified records. Only the Washington National Records Center is equipped to store records that have been assigned a national security classification of Top Secret, as defined in Executive Order 12958 (3 CFR, 1995 Comp., p. 333) and predecessor orders. For storage of restricted records requiring vault storage (regardless of the level of classification), agencies must contact the records center(s) they wish to use to find out if the center(s) can properly store the records.

(d) Transfers to NARA records centers must be preceded by the submission of a Standard Form 135, Records Transmittal and Receipt. Preparation and submission of this form will meet the requirements for records description provided in § 1228.154(c), except the folder title list required for permanent

and unscheduled records. A folder title list is also required for records that are scheduled for sampling or selection after transfer.

(e) A separate SF 135 is required for each individual records series having the same disposition authority and disposition date.

(f) For further guidance on transfer of records to a NARA records center, consult the NARA Records Center Program web site (<http://www.archives.gov>), or current NARA publications and bulletins by contacting the Office of Regional Records Services (NR), individual NARA regional facilities, or the Washington National Records Center (NWMW).

[64 FR 67667, Dec. 2, 1999, as amended at 66 FR 27027, May 16, 2001; 67 FR 43253, June 27, 2002]

#### § 1228.162 How does an agency transfer vital records to a NARA records center?

For assistance on selecting an appropriate site among NARA facilities for storage of vital records, agencies may contact NARA (NR), 8601 Adelphi Rd., College Park, MD 20740-6001. The actual transfers are governed by the general requirements and procedures in this subpart and 36 CFR part 1236.

#### § 1228.164 What records must be transferred to the National Personnel Records Center (NPRC)?

General Records Schedules 1 and 2 specify that certain Federal civilian personnel, medical, and pay records must be centrally stored at the National Personnel Records Center (Civilian Personnel Records), 111 Winnebago Street, St. Louis, MO 63118. An agency must transfer the following four types of records to the NPRC:

(a) Official personnel folders of separated Federal civilian employees;

(b) Service record cards of employees who separated or transferred on or before December 31, 1947;

(c) Audited individual earnings and pay cards and comprehensive payrolls; and

(d) Employee medical folders of separated Federal civilian employees.

**§ 1228.166 How does an agency transfer records to the National Personnel Records Center (NPRC)?**

(a) Agencies must use the following procedures when transferring records to the NPRC:

(1) Forward the official personnel folder (OPF) and the employee medical folder (EMF) to the National Personnel Records Center at the same time.

(2) Transfer EMFs and OPFs in separate folders.

(b) For further guidance consult the NPRC web site ([http://www.archives.gov/facilities/mo/st\\_louis.html](http://www.archives.gov/facilities/mo/st_louis.html)).

(c) Consult the Office of Personnel Management web site (<http://www.opm.gov/feddata/html/opf.htm>) for the OPM publication The Guide to Personnel Recordkeeping for procedures on the transfer of OPFs and EMFs. (The Guide is also available from the Superintendent of Documents, U.S. Government Printing Office, Mail Stop: SSOP, Washington, DC 20402-9328.)

[64 FR 67667, Dec. 2, 1999, as amended at 67 FR 43253, June 27, 2002]

**§ 1228.168 How can records be used in NARA records centers?**

(a) Agency records transferred to a NARA records center remain in the legal custody of the agency. NARA acts as the agency's agent in maintaining the records. NARA will not disclose the record except to the agency which maintains the record, or under rules established by that agency which are not inconsistent with existing laws.

(b) Federal agencies must use Standard Form (SF) 180, Request Pertaining to Military Records, to obtain information from military service records in the National Personnel Records Center (Military Personnel Records). Agencies may furnish copies of that form to the public to aid in inquiries. Members of the public and non-governmental organizations also may obtain copies of SF 180 by submitting a written request to the National Personnel Records Center (Military Personnel Records), 9700 Page Boulevard, St. Louis, MO 63132. OMB Control Number 3095-0029 has been assigned to the SF 180.

(c) Use Standard Form 127, Request for Official Personnel Folder (Separated Employee), to request transmission of personnel folders of separated employees stored at the National Personnel Records Center.

(d) Use Standard Form 184, Request for Employee Medical Folder (Separated Employee), to request medical folders stored at the National Personnel Records Center.

(e) Use Optional Form 11, Reference Request—Federal Records Center to request medical records transferred to other NARA records centers prior to September 1, 1984. The request must include the name and address of the agency's designated medical records manager.

(f) For any other requests, use the Optional Form 11, Reference Request—Federal Records Centers, a form jointly designated by that agency and NARA, or their electronic equivalents.

**§ 1228.170 How are disposal clearances managed for records in NARA records centers?**

(a) The National Personnel Records Center will destroy records covered by General Records Schedules 1 and 2 in accordance with those schedules without further agency clearance.

(b) NARA records centers will destroy other eligible Federal records only with the written concurrence of the agency having legal custody of the records.

(c) NARA records centers will maintain documentation on the final disposition of records, as required in 36 CFR 1220.36, for the period of time required by General Records Schedule 16.

(d) When NARA approves an extension of retention period beyond the time authorized in the records schedule for records stored in NARA records centers, NARA will notify those affected records centers to suspend disposal of the records (see § 1228.54(e)).

**Subpart K—Facility Standards for Records Storage Facilities**

SOURCE: 64 FR 67642, Dec. 2, 1999, unless otherwise noted.

## GENERAL

**1228.220 What authority applies to this subpart?**

NARA is authorized to establish, maintain and operate records centers for Federal agencies under 44 U.S.C. 2907. NARA is authorized, under 44 U.S.C. 3103, to approve a records center that is maintained and operated by an agency. NARA is also authorized to promulgate standards, procedures, and guidelines to Federal agencies with respect to the storage of their records in commercial records storage facilities. See 44 U.S.C. 2104(a), 2904 and 3102. The regulations in this subpart apply to all records storage facilities Federal agencies use to store, service, and dispose of their records.

**1228.222 What does this subpart cover?**

(a) This subpart covers the establishment, maintenance, and operation of records centers, whether Federally-owned and operated by NARA or another Federal agency, or Federally-owned and contractor operated. This subpart also covers an agency's use of commercial records storage facilities. Records centers and commercial records storage facilities are referred to collectively as records storage facilities. This subpart specifies the minimum structural, environmental, property, and life-safety standards that a records storage facility must meet when the facility is used for the storage of Federal records.

(b) Except where specifically noted, this subpart applies to all records storage facilities. Certain noted provisions apply only to new records storage facilities.

**1228.224 Publications incorporated by reference.**

(a) *General.* The following publications cited in this section are hereby incorporated by reference into this subpart K of part 1228. They are available from the issuing organizations at the addresses listed in this section. They are also available for inspection at the Office of the Federal Register, 800 North Capitol Street NW., suite 700, Washington, DC. This incorporation by reference was approved by the Director

of the Federal Register in accordance with 5 U.S.C. 552(a) and 1 CFR Part 51. These materials are incorporated as they exist on the date of approval, and a document indicating any change in these materials will be published in the FEDERAL REGISTER.

(b) *American Society of Testing and Materials (ASTM) standards.* The following ASTM standard is available from the American Society of Testing and Materials, 100 Barr Harbor Drive, West Conshohocken, PA, 19428-2959, or on-line at [www.astm.org](http://www.astm.org):

E 119-98, Standard Test Methods for Fire Tests of Building Construction and Materials.

(c) *National Fire Protection Association (NFPA) standards.* The following NFPA standards are available from the National Fire Protection Association, 1 Batterymarch Park, P.O. Box 9109, Quincy, MA 02269-9101, or on-line at <http://catalog.nfpa.org>:

NFPA 10, Standard for Portable Fire Extinguishers (1994 Edition).

NFPA 13, Standard for the Installation of Sprinkler Systems (1996 Edition).

NFPA 20, Standard for the Installation of Centrifugal Fire Pumps (1996 Edition).

NFPA 40, Standard for the Storage and Handling of Cellulose Nitrate Motion Picture Film (1997 Edition).

NFPA 42, Code for the Storage of Pyroxylin Plastic (1997 Edition).

NFPA 72, National Fire Alarm Code (1996 Edition).

NFPA 101, Life Safety Code (1997 Edition).

NFPA 221, Standard for Fire Walls and Fire Barrier Walls (1994 Edition).

NFPA 231, Standard for General Storage (1998 Edition).

NFPA 231C, Standard for Rack Storage of Materials (1998 Edition).

NFPA 232, Standard for the Protection of Records (1995 Edition).

NFPA 232A, Guide for Fire Protection of Archives and Records Centers (1995 Edition).

(d) *Underwriters Laboratory (UL) standards.* The following UL standards are available from the Underwriters Laboratory at [www.ul.com](http://www.ul.com) or from Global Engineering Documents, 15 Inverness Way East, Englewood, CO 80112:

UL 611, Central-Station Burglar-Alarm Systems (February 22, 1996).

UL 827, Central-Station Alarm Services (April 23, 1999).

UL 1076, Proprietary Burglar Alarm Units and Systems (February 1, 1999).

(e) *American Society of Heating, Refrigerating and Air-Conditioning Engineers, Inc. (ASHRAE) standards.* The following ASHRAE standards are available from ASHRAE at ASHRAE Customer Service, 1791 Tullie Circle NE, Atlanta, GA 30329 or online at *www.ASHRAE.org*:

ANSI/ASHRAE 55-1992, Thermal Environmental Conditions for Human Occupancy.  
ANSI/ASHRAE 62-1989, Ventilation for Acceptable Indoor Air Quality.

(f) *American National Standards Institute (ANSI) standards.* The following ANSI standards are available from the American National Standards Institute, 11 West 42nd St., New York, NY 10036:

ANSI/NAPM IT9.18-1996, Imaging Materials—Processed Photographic Plates—Storage Practices.

ANSI/NAPM IT9.20-1996, Imaging Materials—Reflection Prints—Storage Practices.

ANSI/NAPM IT9.23-1996, Imaging Materials—Polyester Base Magnetic Tape—Storage.

ANSI/PIMA IT9.11-1998, Imaging Materials—Processed Safety Photographic Films—Storage.

ANSI/PIMA IT9.25-1998, Imaging Materials—Optical Disc Media—Storage.

[64 FR 67642, Dec. 2, 1999, as amended at 67 FR 79518, Dec. 30, 2002]

#### § 1228.226 Definitions.

The following definitions apply to this subpart:

*Auxiliary spaces* mean non-records storage areas such as offices, research rooms, other work and general storage areas but excluding boiler rooms or rooms containing equipment operating with a fuel supply such as generator rooms.

*Commercial records storage facility* has the meaning specified in § 1220.14 of this chapter.

*Existing records storage facility* means any records center or commercial records storage facility used to store records on January 2, 2000, and that has stored records continuously since that date.

*Fire barrier wall* means a wall, other than a fire wall, having a fire resistance rating, constructed in accordance with NFPA 221 (1994), Standard for Fire Walls and Fire Barrier Walls, Chapter 4.

*Licensed fire protection engineer* means a licensed or registered professional en-

gineer with a recognized specialization in fire protection engineering. For those States that do not separately license or register fire protection engineers, a licensed or registered professional engineer with training and experience in fire protection engineering, operating within the scope of that licensing or registration, who is also a professional member of the Society of Fire Protection Engineers.

*Must* and *provide* mean that a provision is mandatory.

*New records storage facility* means any records center or commercial records storage facility established or converted for use as a records center or commercial records storage facility on or after January 3, 2000.

*Permanent record* has the meaning specified in § 1220.14 of this chapter.

*Records center* has the meaning specified in § 1220.14 of this chapter.

*Records storage area* means the area containing records that is enclosed by four fire walls, the floor, and the ceiling.

*Records storage facility* has the meaning specified in § 1220.14 of this chapter.

*Sample/select records* means records whose final disposition requires an analytical or statistical sampling prior to final disposition authorization, in which some percentage of the original accession will be retained as permanent records.

*Should* or *may* means that a provision is recommended or advised but not required.

*Temporary record* has the meaning specified in § 1220.14 of this chapter.

*Unscheduled records* has the meaning specified in § 1220.14 of this chapter.

[64 FR 67642, Dec. 2, 1999; 64 FR 68946, Dec. 9, 1999]

#### FACILITY STANDARDS

#### § 1228.228 What are the facility requirements for all records storage facilities?

(a) The facility must be constructed with non-combustible materials and building elements, including walls, columns and floors. An agency may request a waiver of this requirement from NARA for an existing records storage facility with combustible

building elements to continue to operate until October 1, 2009. In its request for a waiver, the agency must provide documentation that the facility has a fire suppression system specifically designed to mitigate this hazard and that the system meets the requirements of § 1228.230(s). Requests must be submitted to the Director, Space and Security Management Division (NAS), National Archives and Records Administration, 8601 Adelphi Road, College Park, MD 20740-6001.

(b) A facility with two or more stories must be designed or certified by a licensed fire protection engineer and civil/structural engineer to avoid catastrophic failure of the structure due to an uncontrolled fire on one of the intermediate floor levels.

(c) The building must be sited a minimum of five feet above and 100 feet from any 100 year flood plain areas, or be protected by an appropriate flood wall that conforms to local or regional building codes.

(d) The facility must be designed in accordance with regional building codes to provide protection from building collapse or failure of essential equipment from earthquake hazards, tornados, hurricanes and other potential natural disasters.

(e) Roads, fire lanes and parking areas must permit unrestricted access for emergency vehicles.

(f) A floor load limit must be established for the records storage area by a licensed structural engineer. The limit must take into consideration the height and type of the shelving or storage equipment, the width of the aisles, the configuration of the space, etc. The allowable load limit must be posted in a conspicuous place and must not be exceeded.

(g) The facility must ensure that the roof membrane does not permit water to penetrate the roof. NARA strongly recommends that this requirement be met by not mounting equipment on the roof and placing nothing else on the roof that may cause damage to the roof membrane. Alternatively, a facility may meet this requirement with stringent design specifications for roof-mounted equipment in conjunction with a periodic roof inspection program

performed by appropriately certified professionals.

(1) New records storage facilities must meet the requirements in this paragraph (g) January 3, 2000.

(2) Existing facilities must meet the requirements in this paragraph (g) no later than October 1, 2009.

(h) Piping (with the exception of fire protection sprinkler piping and storm water roof drainage piping) must not be run through records storage areas unless supplemental measures such as gutters or shields are used to prevent water leaks and the piping assembly is inspected for potential leaks regularly. If drainage piping from roof drains must be run through records storage areas, the piping must be run to the nearest vertical riser and must include a continuous gutter sized and installed beneath the lateral runs to prevent leakage into the storage area. Vertical pipe risers required to be installed in records storage areas must be fully enclosed by shaft construction with appropriate maintenance access panels.

(1) New records storage facilities must meet the requirements in this paragraph (h) January 3, 2000.

(2) Existing facilities must meet the requirements in this paragraph (h) no later than October 1, 2009.

(i) The following standards apply to records storage shelving:

(1) All storage shelving must be designed and installed to provide seismic bracing that meets the requirements of the applicable regional building code;

(2) Steel shelving or other open-shelf records storage equipment must be braced to prevent collapse under full load. Each shelving unit must be industrial style shelving rated at least 50 pounds per cubic foot supported by the shelf;

(3) Compact mobile shelving systems (if used) must be designed to permit proper air circulation and fire protection (detailed specifications that meet this requirement can be provided by NARA by writing to Director, Space and Security Management Division (NAS), National Archives and Records Administration, 8601 Adelphi Road, College Park, MD 20740-6001.).

(j) The area occupied by the records storage facility must be equipped with an anti-intrusion alarm system, or



equivalent, meeting the requirements of Underwriters Laboratory (UL) Standard 1076, Proprietary Burglar Alarm Units and Systems (February 1, 1999), level AA, to protect against unlawful entry after hours and to monitor designated interior storage spaces. This intrusion alarm system must be monitored in accordance with UL Standard 611, Central-Station Burglar-Alarm Systems (February 22, 1996).

(k) The facility must comply with the requirements for a Level III facility as defined in the Department of Justice, U. S. Marshals Service report "Vulnerability Assessment of Federal Facilities" dated June 28, 1995. These requirements are provided in Appendix A to this Part 1228. Agencies may require compliance with Level IV or Level V facility security requirements if the facility is classified at the higher level.

(l) Records contaminated by hazardous materials, such as radioactive isotopes or toxins, infiltrated by insects, or exhibiting active mold growth must be stored in separate areas having separate air handling systems from other records.

(m) To eliminate damage to records and/or loss of information due to insects, rodents, mold and other pests that are attracted to organic materials under specific environmental conditions, the facility must have an Integrated Pest Management program as defined in the Food Protection Act of 1996 (Section 303, Public Law 104-170, 110 Stat. 1512). This states in part that Integrated Pest Management is a sustainable approach to managing pests by combining biological, cultural, physical, and chemical tools in a way that minimizes economic, health, and environmental risks. The IPM program emphasizes three fundamental elements:

(1) *Prevention.* IPM is a preventive maintenance process that seeks to identify and eliminate potential pest access, shelter, and nourishment. It also continually monitors for pests themselves, so that small infestations do not become large ones;

(2) *Least-toxic methods.* IPM aims to minimize both pesticide use and risk through alternate control techniques and by favoring compounds, formula-

tions, and application methods that present the lowest potential hazard to humans and the environment; and

(3) *Systems approach.* The IPM pest control contract must be effectively coordinated with all other relevant programs that operate in and around a building, including plans and procedures involving design and construction, repairs and alterations, cleaning, waste management, food service, and other activities.

(n) For new records storage facilities only, the additional requirements in this paragraph (n) must be met:

(1) Do not install mechanical equipment containing motors rated in excess of 1 HP within records storage areas (either floor mounted or suspended from roof support structures).

(2) Do not install high-voltage electrical distribution equipment (i.e., 13.2kv or higher switchgear and transformers) within records storage areas (either floor mounted or suspended from roof support structures).

(3) A redundant source of primary electric service such as a second primary service feeder should be provided to ensure continuous, dependable service to the facility especially to the HVAC systems, fire alarm and fire protection systems. Manual switching between sources of service is acceptable.

(4) The facility must be kept under positive air pressure especially in the area of the loading dock. In addition, to prevent fumes from vehicle exhausts from entering the facility, air intake louvers must not be located in the area of the loading dock, adjacent to parking areas or in any location where a vehicle engine may be running for any period of time. Loading docks must have an air supply and exhaust system that is separate from the remainder of the facility.

[64 FR 67642, Dec. 2, 1999; 64 FR 68946, Dec. 9, 1999]

**§ 1228.230 What are the fire safety requirements that apply to records storage facilities?**

(a) The fire detection and protection systems must be designed or certified by a licensed fire protection engineer.

(b) All walls separating records storage areas from each other and from other storage areas in the building

must be 4-hour fire resistant. The records storage areas must not exceed a total capacity of 250,000 cubic feet of records each and must be constructed to prevent migration of fire and smoke to other spaces of the building. If the facility does not have fire compartmentalization of its records storage area or has compartmentalized records storage areas larger than 250,000 cubic feet, the facility may not store more than 250,000 cubic feet total of Federal records in the records storage area.

(c) Fire barrier walls that meet the following specifications must be provided:

(1) For existing records storage facilities, at least one-hour-rated fire barrier walls must be provided between the records storage areas and other auxiliary spaces.

(2) For new records storage facilities, two-hour-rated fire barrier walls must be provided between the records storage areas and other auxiliary spaces. One exterior wall of each stack area must be designed with a maximum fire resistive rating of one hour, or, if rated more than one hour, there must be at least one knock-out panel in one exterior wall of each stack area.

(d) Penetrations in the walls must not reduce the specified fire resistance ratings. The fire resistance ratings of structural elements and construction assemblies must be in accordance with American Society of Testing and Materials E 119-98, Standard Test Methods for Fire Tests of Building Construction and Materials.

(e) The fire resistive rating of the roof must be a minimum of ½ hour for all records storage facilities. For new records storage facilities, the fire resistive rating of the roof must also be a maximum of 1 hour.

(f) Openings in fire barrier walls separating records storage areas must be avoided to the greatest extent possible. If openings are necessary, they must be protected by self-closing or automatic Class A fire doors, or equivalent doors that maintain the same rating as the wall.

(g) Roof support structures that cross or penetrate fire barrier walls must be cut and supported independently on each side of the fire barrier wall.

(h) If fire barrier walls are erected with expansion joints, the joints must be protected to their full height.

(i) For new records storage facilities, building columns in the records storage areas must be 4-hour fire resistant from the floor to slab above or to the location where they connect to the roof framing system. For existing records storage facilities, the building columns must be at least 2-hour fire resistant.

(j) Automatic roof vents for routine ventilation purposes must not be designed into new records storage facilities. Automatic roof vents, designed solely to vent in the case of a fire, with a temperature rating at least twice that of the sprinkler heads are acceptable.

(k) Where lightweight steel roof or floor supporting members (e.g., bar joists having top chords with angles 2 by 1½ inches or smaller, ¼-inch thick or smaller, and 1³⁄₁₆-inch or smaller web diameters) are present, they must be protected either by applying a 10-minute fire resistive coating to the top chords of the joists, or by retrofitting the sprinkler system with large drop sprinkler heads. If a fire resistive coating is applied, it must be a product that will not release (off gas) harmful fumes into the facility. If fire resistive coating is subject to air erosion or flaking, it must be fully enclosed in a drywall containment constructed of metal studs with fire retardant drywall. Retrofitting may require modifications to the piping system to ensure that adequate water capacity and pressure are provided in the areas to be protected with these large drop sprinkler heads.

(l) No open flame (oil or gas) unit heaters or equipment may be installed or used in any records storage area.

(m) For existing records storage facilities, boiler rooms or rooms containing equipment operating with a fuel supply (such as generator rooms) must be separated from records storage areas by 2-hour-rated fire barrier walls with no openings directly from these rooms to the records storage areas. Such areas must be vented directly to the outside to a location where fumes will not be drawn back into the facility.

(n) For new records storage facilities, boiler rooms or rooms containing equipment operating with a fuel supply (such as generator rooms) must be separated from records storage areas by 4-hour-rated fire barrier walls with no openings directly from these rooms to the records storage areas. Such areas must be vented directly to the outside to a location where fumes will not be drawn back into the facility.

(o) For new records storage facilities, fuel supply lines must not be installed in areas containing records and must be separated from such areas with 4-hour rated construction assemblies.

(p) Equipment rows running perpendicular to the wall must comply with NFPA 101 (1997), Life Safety Code, with respect to egress requirements.

(q) No oil-type electrical transformers, regardless of size, except thermally protected devices included in fluorescent light ballasts, may be installed in the records storage areas. All electrical wiring must be in metal conduit, except that armored cable may be used where flexible wiring connections to light fixtures are required. Battery charging areas for electric forklifts must be separated from records storage areas with at least a 2-hour rated fire barrier wall.

(r) Hazardous materials, including records on cellulose nitrate film, must not be stored in records storage areas. Nitrate motion picture film and nitrate sheet film may be stored in separate areas that meet the requirements of the appropriate NFPA standard, NFPA 40 (1997), Standard for the Storage and Handling of Cellulose Nitrate Motion Picture Film, or NFPA 42 (1997), Code for the Storage of Pyroxylin Plastic.

(s) All records storage and adjoining areas must be protected by a professionally-designed fire-safety detection and suppression system that is designed to limit the maximum anticipated loss in any single fire event to a maximum of 300 cubic feet of records destroyed by fire. Section 1228.242 specifies how to document compliance with this requirement.

**§ 1228.232 What are the requirements for environmental controls for records storage facilities?**

(a) *Paper-based temporary records.* Paper-based temporary records must be stored under environmental conditions that prevent the active growth of mold. Exposure to moisture through leaks or condensation, relative humidities in excess of 70%, extremes of heat combined with relative humidity in excess of 55%, and poor air circulation during periods of elevated heat and relative humidity are all factors that contribute to mold growth.

(b) *Nontextual temporary records.* Nontextual temporary records, including microforms and audiovisual and electronic records, must be stored in records storage space that will ensure their preservation for their full retention period. New records storage facilities that store nontextual temporary records must meet the requirements in this paragraph (b) January 3, 2000. Existing records storage facilities that store nontextual temporary records must meet the requirements in this paragraph (b) no later than October 1, 2009. At a minimum, nontextual temporary records must be stored in records storage space that meets the requirements for medium term storage set by the appropriate standard in this paragraph (b). In general, medium term conditions as defined by these standards are those that will ensure the preservation of the materials for at least 10 years with little information degradation or loss. Records may continue to be usable for longer than 10 years when stored under these conditions, but with an increasing risk of information loss or degradation with longer times. If temporary records require retention longer than 10 years, better storage conditions (cooler and drier) than those specified for medium term storage will be needed to maintain the usability of these records. The applicable standards are:

(1) ANSI/PIMA IT9.11-1998, Imaging Materials—Processed Safety Photographic Films—Storage;

(2) ANSI/NAPM IT9.23-1996, Imaging Materials—Polyester Base Magnetic Tape—Storage;

§ 1228.234

(3) ANSI/PIMA IT9.25-1998, Imaging Materials—Optical Disc Media—Storage;

(4) ANSI /NAPM IT9.20-1996, Imaging Materials—Reflection Prints—Storage Practices; and/or

(5) ANSI/NAPM IT9.18-1996, Imaging Materials—Processed Photographic Plates—Storage Practices.

(c) *Paper-based permanent, unscheduled and sample/select records.* Paper-based permanent, unscheduled, and sample/select records must be stored in records storage space that provides 24 hour/365 days per year air conditioning (temperature, humidity, and air exchange) equivalent to that required for office space. See ASHRAE Standard 55-1992, Thermal Environmental Conditions for Human Occupancy, and ASHRAE Standard 62-1989, Ventilation for Acceptable Indoor Air Quality, for specific requirements. New records storage facilities that store paper-based permanent, unscheduled, and/or sample/select records must meet the requirement in this paragraph (c) January 3, 2000. Existing storage facilities that store paper-based permanent, unscheduled, and/or sample/select records must meet the requirement in this paragraph (c) no later than October 1, 2009.

(d) *Nontextual permanent, unscheduled, and/or sample/select records.* All records storage facilities that store microfilm, audiovisual, and/or electronic permanent, unscheduled, and/or sample/select records must comply with the storage standards for permanent and unscheduled records in parts 1230, 1232, and/or 1234 of this chapter, respectively.

HANDLING DEVIATIONS FROM NARA'S FACILITY STANDARDS

**§ 1228.234 What rules apply if there is a conflict between NARA standards and other regulatory standards that a facility must follow?**

(a) If any provisions of this subpart conflict with local or regional building codes, the following rules of precedence apply:

(1) Between differing levels of fire protection and life safety, the more stringent provision applies; and

(2) Between mandatory provisions that cannot be reconciled with a re-

36 CFR Ch. XII (7-1-03 Edition)

quirement of this subpart, the local or regional code applies.

(b) If any of the provisions of this subpart conflict with mandatory life safety or ventilation requirements imposed on underground storage facilities by 30 CFR chapter I, 30 CFR chapter I applies.

(c) NARA reserves the right to require documentation of the mandatory nature of the conflicting code and the inability to reconcile that provision with NARA requirements.

**§ 1228.236 How does an agency request a waiver from a requirement in this subpart?**

(a) *Types of waivers that may be approved.* NARA may approve exceptions to one or more of the standards in this subpart for:

(1) Systems, methods, or devices that are demonstrated to have equivalent or superior quality, strength, fire resistance, effectiveness, durability, and safety to those prescribed by this subpart;

(2) Existing agency records centers that met the previous NARA standards in effect on January 2, 2000, but that do not meet a new standard required to be in place on January 3, 2000; and

(3) The application of roof requirements in §§ 1228.228 and 1228.230 to underground storage facilities.

(b) *Where to submit a waiver request.* The agency submits a waiver request, containing the information specified in paragraphs (c), (d), and/or (e) of this section to the Director, Security and Space Management Division (NAS), National Archives and Records Administration, 8601 Adelphi Rd., College Park, MD 20740-6001.

(c) *Content of request for waivers for equivalent or superior alternatives.* The agency's waiver request must contain:

(1) A statement of the specific provision(s) of this subpart for which a waiver is requested, a description of the proposed alternative, and an explanation how it is equivalent to or superior to the NARA requirement; and

(2) Supporting documentation that the alternative does not provide less protection for Federal records than

that which would be provided by compliance with the corresponding provisions contained in this subpart. Documentation may take the form of certifications from a licensed fire protection engineer or a structural or civil engineer, as appropriate; reports of independent testing; reports of computer modeling; and/or other supporting information.

(d) *Content of request for waiver for previously compliant agency records center.* The agency's waiver request must identify which requirement(s) the agency records center cannot meet and provide a plan with milestones for bringing the center into compliance.

(e) *Content of request for waiver of roof requirements for underground facility.* The agency's waiver request must identify the location of the facility and whether the facility is a drift entrance facility or a vertical access facility.

**§ 1228.238 How does NARA process a waiver request?**

(a) *Waiver for equivalent or superior alternative.* NARA will review the waiver request and supporting documentation.

(1) If in NARA's judgement the supporting documentation clearly supports the claim that the alternative is equivalent or superior to the NARA requirement, NARA will grant the waiver and notify the requesting agency within 30 calendar days.

(2) If NARA questions whether supporting documentation demonstrates that the proposed alternative offers at least equal protection to Federal records, NARA will consult the appropriate industry standards body or other qualified expert before making a determination. NARA will notify the requesting agency within 30 calendar days of receipt of the request that consultation is necessary and will provide a final determination within 60 calendar days. If NARA does not grant the waiver, NARA will furnish a full explanation of the reasons for its decision.

(b) *Waiver of new requirement for existing agency records center.* NARA will review the agency's waiver request and plan to bring the facility into compliance.

(1) NARA will approve the request and plan within 30 calendar days if NARA judges the planned actions and

time frames for bringing the facility into compliance are reasonable.

(2) If NARA questions the feasibility or reasonableness of the plan, NARA will work with the agency to develop a revised plan that NARA can approve and the agency can implement. NARA may grant a short-term temporary waiver, not to exceed 180 calendar days, while the revised plan is under development.

(c) *Waiver of roof requirements for underground storage facilities.* NARA will normally grant the waiver and notify the requesting agency within 10 work days if the agency has not also requested a waiver of a different requirement under § 1228.236. If the agency has another waiver request pending for the same facility, NARA will respond to all of the waiver requests at the same time and within the longest time limits.

FACILITY APPROVAL AND INSPECTION REQUIREMENTS

**§ 1228.240 How does an agency request authority to establish or relocate records storage facilities?**

(a) *General policy.* Agencies are responsible for ensuring that records in their legal custody are stored in appropriate space as outlined in this subpart. Under § 1228.156(a), agencies are responsible for initiating action to remove records from space that does not meet these standards if deficiencies are not corrected within 6 months after initial discovery of the deficiencies by NARA or the agency and to complete removal of the records within 18 months after initial discovery of the deficiencies.

(1) *Agency records centers.* Agencies must obtain prior written approval from NARA before establishing or relocating an agency records center. Each separate agency records center must be specifically approved by NARA prior to the transfer of any records to that individual facility. If an agency records center has been approved for the storage of Federal records of one agency, any other agency that proposes to store its records in that facility must still obtain NARA approval to do so.

(2) *Commercial records storage facilities.* An agency may contract for commercial records storage services. However,

before any agency records are transferred to a commercial records storage facility, the transferring agency must ensure that the facility meets all of the requirements for an agency records storage facility set forth in this subpart and must submit the documentation required in paragraph (e) of this section.

(b) *Exclusions.* For purposes of this section, the term “agency records center” excludes NARA-owned and operated records centers. For purposes of this section and §1228.244, the term “agency records center” also excludes agency records staging and/or holding areas with a capacity for containing less than 25,000 cubic feet of records. However, such records centers and areas, including records centers operated and maintained by NARA, must comply with the facility standards in §§1228.228 through 1228.232.

(c) *Content of requests for agency records centers.* Requests for authority to establish or relocate an agency records center, or to use an agency records center operated by another agency, must be submitted in writing to the Director, Space and Security Management Division (NAS), National Archives and Records Administration, 8601 Adelphi Road, College Park, MD 20740-6001.

(1) The request must identify the specific facility and, for requests to establish or relocate the agency’s own records center, document compliance with the standards in this subpart. Documentation requirements for §1228.230(s) are specified in §1228.242.

(2) If the request is for approval of an existing agency records center that did not comply with the requirements of this subpart in effect on January 2, 2000, the request must also contain the agency’s plan to modify the facility to bring it into compliance with current requirements within a three year period. Such requests must be submitted to NARA no later than July 1, 2000.

(d) *Approval of requests for agency records centers.* NARA will review the submitted documentation to ensure the facility demonstrates full compliance with the standards in this subpart. For requests submitted under paragraph (c)(2) of this section, NARA also will review the submitted plan to ensure

that the plan is realistic. NARA reserves the right to visit the facility, if necessary, to make the determination of compliance. NARA will inform the agency of its decision within 45 calendar days after the request is received, and will provide the agency information on the areas of noncompliance if the request is denied. Requests will be denied only if NARA determines that the facility does not demonstrate full compliance with the standards in this subpart. Approvals will be valid for a period of 10 years, unless the facility is materially changed before then or an agency or NARA inspection finds that the facility does not meet the standards in this subpart. Material changes require submission of a new request for NARA approval.

(e) *Documentation requirements for storing Federal records in commercial records storage facilities.* At least 45 calendar days before an agency first transfers records to a commercial records storage facility, the agency must submit documentation to NARA that the facility complies with the standards in this subpart. The documentation may take the form of a copy of the agency’s contract that incorporates this subpart in its provisions or a statement from the agency records officer that certifies that the facility meets the standards in this subpart. An agency must provide the documentation for each separate commercial records storage facility where its records will be stored. Documentation must be sent to the Director, Space and Security Management Division (NAS), National Archives and Records Administration, 8601 Adelphi Road, College Park, MD 20740-6001. The agency must submit updated documentation to NARA every 10 years if it continues to store records in that commercial records storage facility.

**§1228.242 What does an agency have to do to certify a fire-safety detection and suppression system?**

(a) *Content of documentation.* The agency must submit documentation to the Director, Space and Security Management Division (NAS), National Archives and Records Administration, 8601 Adelphi Road, College Park, MD 20740-6001, that describes the space

being protected (e.g., the type and stacking height of the storage equipment used, or how the space is designed, controlled, and operated) and the characteristics of the fire-safety detection and suppression system used. The documentation must demonstrate how that system meets the requirement in § 1228.230(s) through:

(1) A statement that the facility is using a NARA certified system as described in Appendix B to this part;

(2) A report of the results of independent live fire testing (Factory Mutual, Underwriters Laboratories or equivalent); or

(3) A report of the results of computer modeling, and a certification by a licensed fire protection engineer that the system has been designed to limit the maximum anticipated loss in any single fire event to a maximum of 300 cubic feet of records destroyed by fire. If this method of demonstrating compliance is chosen, the description of the system must include specific references to any industry standards used in the design, such as those issued by the National Fire Protection Association (see NFPA 13, NFPA 231, NFPA 231C, NFPA 232 and NFPA 232A).

(b) *NARA action.* (1) NARA will approve the fire-safety detection and suppression system within 10 work days if NARA has previously approved the system design for similarly configured space or if a report of independent testing of a new system design is furnished as documentation.

(2) If, in NARA's judgment, the supporting documentation provided in accordance with paragraph (a)(3) of this section clearly demonstrates compliance with § 1228.230(s), NARA will approve the fire-safety detection and suppression system within 30 calendar days.

(3) If NARA questions whether supporting documentation demonstrates compliance with § 1228.230(s), NARA will consult the appropriate industry standards body or other qualified expert before making a determination. Before any consultation, NARA may ask the agency for additional clarifying information. NARA will notify the requesting agency within 30 calendar days of receipt of the request that consultation is necessary and will

provide a final determination within 60 calendar days. If NARA does not approve the system, NARA will furnish a full explanation of the reasons for its decision.

(4) NARA will maintain a list of approved alternative systems.

**§ 1228.244 When may NARA conduct an inspection of a records storage facility?**

(a) At the time an agency submits a request to establish an agency records center, pursuant to § 1228.240, NARA may conduct an inspection of the proposed facility to ensure that the facility complies fully with the standards in this subpart. NARA may also conduct periodic inspections of agency records centers so long as such facility is used as an agency records center. NARA will inspect its own records center facilities on a periodic basis to ensure that they are in compliance with the requirements of this subpart.

(b) Agencies must ensure, by contract or otherwise, that agency and NARA officials, or their delegates, have the right to inspect commercial records storage facilities to ensure that such facilities fully comply with the standards in this subpart. NARA may conduct periodic inspections of commercial records storage facilities so long as agencies use such facilities to store agency records. The using agency, not NARA, will be responsible for paying any fee or charge assessed by the commercial records storage facility for NARA's conducting an inspection.

(c) NARA will contact the agency operating the records center or the agency holding a contract with a commercial records storage facility in advance to set a date for the inspection.

**Subpart L—Transfer of Records to the National Archives of the United States**

SOURCE: 45 FR 5705, Jan. 24, 1980. Redesignated at 50 FR 15723, Apr. 19, 1985. Redesignated further at 64 FR 67667, Dec. 2, 1999.

**§ 1228.260 Authority.**

(a) *Transfer of records.* The Archivist of the United States is authorized by 44 U.S.C. 2107 to:

**§ 1228.262**

**36 CFR Ch. XII (7-1-03 Edition)**

(1) Accept for deposit with the National Archives of the United States the records of a Federal agency or of the Congress determined by the Archivist of the United States to have sufficient historical or other value to warrant their continued preservation by the U.S. Government; and

(2) Direct and effect the transfer to the National Archives of the United States of Federal agency records that have been in existence for more than 30 years and that have been determined by the Archivist of the United States to have sufficient historical or other value to warrant their continued preservation by the U.S. Government.

(b) *Custody of records transferred.* Under 44 U.S.C. 2108, the Archivist of the United States is responsible for the custody, use, and withdrawal of records transferred to him.

(c) *Transferred records subject to statutory or other restrictions.* When records, the use of which is subject to statutory limitations and restrictions, are so transferred, permissive and restrictive statutory provisions concerning the examination and use of records applicable to the head of the transferring agency are applicable to the Archivist of the United States and the employees of the National Archives and Records Administration.

[54 FR 2111, Jan. 19, 1989. Redesignated at 55 FR 27433, July 2, 1990, as amended at 57 FR 22432, May 28, 1992]

**§ 1228.262 Types of records to be transferred.**

(a) *General.* Records that have been determined by the Archivist of the United States to have sufficient historical or other value to warrant preservation; i.e., appraised by NARA and identified as permanent records, are normally transferred to the National Archives of the United States when:

(1) They are 30 years old; or

(2) At any age when:

(i) The originating agency no longer needs to use the records for the purpose for which they were created or in its regular current business; or

(ii) Agency needs will be satisfied by use of the records in NARA research rooms or by copies of the records; and restrictions on the use of records are acceptable to NARA and do not violate

the Freedom of Information Act (5 U.S.C. 552). Records appraised as permanent that are not yet eligible for transfer because of agency needs or restrictions may be stored in a Federal records center pending transfer. (See subpart I of this part.)

(b) *Archival depositories.* NARA reserves the right to determine and change the archival depository in which records transferred to the National Archives of the United States are stored. Such determinations are normally made as follows:

(1) *Presidential libraries.* Records appropriate for preservation in a Presidential library because they can most effectively be used in conjunction with materials already in that library.

(2) *Regional Archives.* (i) Records of field offices of Federal agencies, except for records of agency field offices located in the Washington, DC area;

(ii) Records including both headquarters and field office records of regional agencies such as the Tennessee Valley Authority; and

(iii) Other records determined by NARA to be of primarily regional or local interest.

(3) *National Archives Building and other Washington, DC area depositories.*

(i) Records of Washington, DC area field offices of Federal agencies and other records relating to the District of Columbia and the Washington, DC area, such as records of the National Capital Planning Commission;

(ii) All other records not deposited in a Presidential library or Regional Archives.

[42 FR 57315, Nov. 2, 1977, as amended at 46 FR 60206, Dec. 9, 1981. Redesignated and amended at 50 FR 15723, 15725, Apr. 19, 1985. Redesignated at 55 FR 27433, July 2, 1990, as amended at 57 FR 22432, May 28, 1992]

**§ 1228.264 Certification for retention of records in agency custody.**

(a) Permanent records shall be transferred to the National Archives of the United States when the records have been in existence for more than 30 years unless the head of the agency which has custody of the records certifies in writing to the Archivist that the records must be retained in agency custody for use in the conduct of the regular current business of the agency.



Records that are scheduled in a NARA-approved records schedule to be transferred to the National Archives of the United States after a specified period of time are subject to the certification requirement only if the records are not transferred as scheduled.

(b) In order to certify that records must be retained for the conduct of regular current business, an agency should consider the following factors:

(1) Character of use (to be retained by an agency, records should be used for the normal routine business of the agency at the time of certification);

(2) Frequency of use (to be retained by an agency, records should be used more than one time per month per file unit); and,

(3) Preservation of the records (to be retained by an agency, permanently valuable records should be preserved in accordance with NARA guidelines).

(c) The written certification of need of a series of 30-year-old records for current agency business must:

(1) Include a comprehensive description and location of records to be retained;

(2) Cite the NARA approved authority for the disposition of the records if scheduled (SF 115 item number);

(3) Describe the current business for which the records are required;

(4) Estimate the length of time the records will be needed by the agency for current business (if no date is provided by the agency, approved certification requests will be effective for a maximum of five years);

(5) Explain why the current needs of the agency cannot be met by the services NARA provides for records deposited with the National Archives of the United States; and,

(6) If the records are being retained to enable the agency to provide routine public reference, cite the statute authorizing this agency activity.

(d) NARA will not accept an agency certification that a specific body of records over 30 years old, regardless of physical form or characteristics, is being used for the "conduct of the regular current business," if that agency is retaining such records primarily to:

(1) Provide to persons outside the agency access which can be provided by NARA; or

(2) Function as an agency archives, unless specifically authorized by statute or NARA.

[57 FR 22433, May 28, 1992]

#### § 1228.266 Audiovisual records.

The following types of audiovisual records appraised as permanent shall be transferred to the National Archives as soon as they become inactive or whenever the agency cannot provide proper care and handling of the records, including adequate storage conditions, to facilitate their preservation by the National Archives (see part 1232 of this chapter). In general the physical types described below constitute the minimum record elements for archival purposes that are required to provide for future preservation, duplication, and reference needs.

(a) *Motion pictures.* (1) Agency-sponsored or produced motion picture films (e.g., public information films) whether for public or internal use:

(i) Original negative or color original plus separate optical sound track;

(ii) Intermediate master positive or duplicate negative plus optical track sound track; and,

(iii) Sound projection print and video recording, if both exist.

(2) Agency-acquired motion picture films: Two projection prints in good condition or one projection print and one videotape.

(3) Unedited footage, outtakes and trims (the discards of film productions) that are properly arranged, labeled, and described and show unstaged, unrehearsed events of historical interest or historically significant phenomena:

(i) Original negative or color original; and

(ii) Matching print or videotape.

(b) *Still pictures.* (1) For black-and-white photographs, an original negative and a captioned print although the captioning information can be maintained in another file such as a data base if the file number correlation is clear. If the original negative is nitrate, unstable acetate, or glass based, a duplicate negative on a polyester base is also needed.

(2) For color photographs, the original color negative, color transparency, or color slide; a captioned print of the

§ 1228.268

36 CFR Ch. XII (7-1-03 Edition)

original color negative; and/or captioning information as described above if for an original color transparency or original color slide; and a duplicate negative, or slide, or transparency, if they exist.

(3) For slide sets, the original and a reference set, and the related audio recording and script.

(4) For other pictorial records such as posters, original art work, and filmstrips, the original and a reference copy.

(c) *Sound recordings.* (1) Disc recordings:

(i) For conventional disc recordings, the master tape and two disc pressings of each recording, typically a vinyl copy for playback at 33 $\frac{1}{3}$  revolutions per minute (rpm).

(ii) For compact discs, the origination recording regardless of form and two compact discs.

(2) For analog audio recordings on magnetic tape (open reel, cassette, or cartridge), the original tape, or the earliest available generation of the recording, and a subsequent generation copy for reference. Section 1232.30(d) of this subchapter requires the use of open-reel analog magnetic tape for original audio recordings.

(d) *Video recordings.* (1) For videotape, the original or earliest generation videotape and a copy for reference. Section 1232.30(c) of this subchapter requires the use of industrial-quality or professional videotapes for use as originals, although VHS copies can be transferred as reference copies.

(2) For video discs, the premaster videotape used to manufacture the video disc and two copies of the disc. Video discs that depend on interactive software and nonstandard equipment may not be acceptable for transfer.

(e) *Finding aids and production documentation.* The following records shall be transferred to the National Archives with the audiovisual records to which they pertain.

(1) Existing finding aids such as data sheets, shot lists, continuities, review sheets, catalogs, indexes, list of captions, and other documentation that are helpful or necessary for the proper identification, or retrieval of audiovisual records. Agencies should contact the appropriate Special Media Archives

Services Division unit, to determine the type of hardware and software that is currently acceptable for transfer to the National Archives as an agency electronic finding aid that will accompany its audiovisual records. In general, however, agencies must transfer two copies of the electronic finding aid, one in its native format with its field structure documented, and a second copy in a contemporary format available at the time of transfer that NARA will be able to support and import to its database.

(2) Production case files or similar files that include copies of production contracts, scripts, transcripts, and appropriate documentation bearing on the origin, acquisition, release, and ownership of the production.

[61 FR 32336, June 24, 1996, as amended at 66 FR 27027, May 16, 2001]

§ 1228.268 **Cartographic and architectural records.**

The following classes of cartographic and architectural records appraised as permanent should be transferred to the National Archives as soon as they become inactive or whenever the agency cannot provide the proper care and handling of the materials to guarantee their preservation.

(a) *Maps and charts.* (1) Manuscript maps; printed and processed maps on which manuscript changes, additions, or annotations have been made for record purposes or which bear manuscript signatures to indicate official approval; and single printed or processed maps that have been attached to or interfiled with other documents of a record character or in any way made an integral part of a record.

(2) Master sets of printed or processed maps in the custody of the agency by which they were issued. Such master sets should be kept segregated from the stock of maps held for distribution and from maps received from other agencies. A master set should include one copy of each edition of a printed or processed map issued.

(3) Computer-related and computer-plotted maps that cannot be reproduced by the National Archives because of destruction of the magnetic tapes or other stored data or because of the unavailability of ADP equipment.

(4) Index maps, card indexes, lists, catalogs, or other finding aids that may be helpful in using the maps transferred.

(5) Records related to preparing, compiling, editing, or printing maps, such as manuscript field notebooks of surveys, triangulation and other geodetic computations, and project folders containing specifications to be followed and appraisals of source materials to be used.

(b) *Aerial photography and remote sensing imagery.* (1) Vertical and oblique negative aerial film, conventional aircraft.

(2) Annotated copy negatives, inter-negatives, rectified negatives, and glass plate negatives from vertical and oblique aerial film, conventional aircraft.

(3) Annotated prints from aerial film, conventional aircraft.

(4) Infrared, ultraviolet, multispectral (multiband), video, imagery radar, and related tapes, converted to a film base.

(5) Indexes and other finding aids in the form of photo mosaics, flight line indexes, coded grids, and coordinate grids.

(c) *Architectural and related engineering drawings.* (1) Design drawings, preliminary and presentation drawings, and models which document the evolution of the design of a building or structure.

(2) Master sets of drawings which document the condition of a building or structure in terms of its initial construction and subsequent alterations. This category includes final working drawings, "as-built" drawings, shop drawings, and repair and alteration drawings.

(3) Drawings of repetitive or standard details of one or more buildings or structures.

(4) "Measured" drawings of existing buildings and original or photocopies of drawings reviewed for approval.

(5) Related finding aids and specifications to be followed.

[42 FR 57315, Nov. 2, 1977. Redesignated at 50 FR 15723, Apr. 19, 1985, and 55 FR 27433, July 2, 1990, as amended at 57 FR 22433, May 28, 1992]

#### § 1228.270 Electronic records.

(a) *Timing of transfers.* Each agency is responsible for the integrity of the permanent records it transfers on physical media to the National Archives of the United States. For records transferred by a media-less method, NARA works with the agency to ensure integrity of the records during the transfer process. To ensure that permanent electronic records are preserved, each Federal agency must transfer electronic records to NARA promptly in accordance with the agency's records disposition schedule. Furthermore, if the agency cannot provide proper care and handling of the media (*see* part 1234 of this chapter), or if the media are becoming obsolete and the agency cannot migrate the records to newer media, the agency must contact NARA to arrange for timely transfer of permanent electronic records, even when sooner than provided in the records schedule.

(b) *Temporary retention of copy.* Each agency must retain a second copy of any permanent electronic records that it transfers to the National Archives of the United States until it receives official notification from NARA that the transfer was successful and that NARA has assumed responsibility for continuing preservation of the records.

(c) *Transfer media.* This paragraph covers the transfer of permanent records to the National Archives; it does not apply to the use or storage of records in agency custody. *See* 36 CFR 1234.30 for the requirements governing the selection of electronic records storage media for current agency use. The agency must use only media that is sound and free from defects for transfers to the National Archives of the United States; the agency must choose reasonable steps to meet this requirement. The approved media and media-less transfer forms are open reel magnetic tape, magnetic tape cartridge; Compact-Disk, Read Only Memory (CD-ROM); and File Transfer Protocol (FTP) as described in paragraphs (c) (1), (2) and (3) of this section.

(1) *Magnetic tape.* Agencies may transfer electronic records to the National Archives on magnetic tape as follows:

(i) Open-reel magnetic tape must be on ½ inch 9-track tape reels recorded

at 1600 or 6250 bpi that meet ANSI X3.39-1986, American National Standard: Recorded Magnetic Tape for Information Interchange (1600 CPI, PE) or ANSI X3.54-1986, American National Standard: Recorded Magnetic Tape for Information Interchange (6250 CPI, Group Coded Recording), respectively.

(ii) Tape cartridges may be 18-track 3480-class cartridges. The 3480-class cartridge must be recorded at 37,871 bpi that meet ANSI X3.180-1990, American National Standard: Magnetic Tape and Cartridge for Information Interchange—18-Track, Parallel, 1/2 inch (12.65 mm), 37871 cpi (1491 cpmm), Group-Coded—Requirements for Recording. The data must be blocked at no more than 32,760 bytes per block.

(iii) Tape cartridges may be DLTtape IV cartridges that must be recorded in an uncompressed format. Agencies interested in transferring scheduled electronic records using a Tape Archive (TAR) utility should contact NARA's Electronic and Special Media Records Services Division (NWME), 8601 Adelphi Rd., College Park, MD 20740-6001 or by email to [cer@nara.gov](mailto:cer@nara.gov) to initiate transfer discussions. The data must be blocked at no more than 32,760 bytes per block and must conform to the standards cited in the table as follows:

If you are copying the records on . . .	. . . then, the standard below applies.
DLTape IV With a DLT 4000 drive.	ISO/IEC 15307:1997, First edition, December 1, 1997, Information technology—Data interchange on 12.7 mm 128-track magnetic tape cartridges—DLT 4 format (20 GB native, 40 GB compressed, 1.5 MB/sec).
DLTape IV with a DLT 7000 drive.	ISO/IEC 15896:1999, First edition, December 15, 1999, Information technology—Data interchange on 12.7 mm 208-track magnetic tape cartridges—DLT 5 format (35 GB native, 70 GB compressed, 5.0 MB/sec).
DLTape IV with a DLT 8000 drive.	ISO/IEC 16382:2000, First edition, May 15, 2000, Information technology—Data interchange on 12.7 mm 208-track magnetic tape cartridges—DLT 6 format (40 GB native, 80 GB compressed, 6.0 MB/sec).

(2) Compact-Disk, Read Only Memory (CD-ROM). Agencies may use CD-ROMs to transfer electronic records scheduled to be preserved in the National Archives. The files on such a CD-ROM must comply with the format

and documentation requirements specified in paragraphs (d) and (e) of this section.

(i) CD-ROMs used for this purpose must conform to ANSI/NISO/ISO 9660-1990, American National Standard for Volume and File Structure of CD-ROM for Information Exchange.

(ii) Permanent electronic records must be stored in discrete files. The CD-ROMs transferred may contain other files, such as software or temporary records, but all permanent records must be in files that contain only permanent records. Agencies must indicate at the time of transfer if a CD-ROM contains temporary records and, if so, where those records are located on the CD-ROM. The agency must also specify whether NARA should return the CD-ROM to the agency or dispose of it after copying the permanent records to an archival medium.

(iii) If permanent electronic records that an agency disseminates on CD-ROM exist on other media, such as magnetic tape, the agency and NARA will mutually agree on the most appropriate medium for transfer of the records to the National Archives of the United States.

(3) *File Transfer Protocol*. Agencies may use File Transfer Protocol (FTP) to transfer electronic records scheduled for preservation at the National Archives of the United States. The files transferred via FTP must comply with the format and documentation requirements specified in paragraphs (d) and (e) of this section.

(i) FTP file structure may use the 64-character Joliet extension naming convention only when letters, numbers, dashes (-), and underscores ( ) are used in the file and/or directory names, with a slash ( / ) used to indicate directory structures. Otherwise, FTP file structure must conform to an 8.3 file naming convention and file directory structure as cited in ANSI/NISO/ISO 9660-1990, American National Standard for Volume and File Structure of CD-ROM for Information Exchange.

(ii) Permanent electronic records must be stored in discrete files, separate from temporary files. All permanent records must be transferred in files that contain only permanent records.

(iii) When permanent electronic records may be disseminated through other types of mechanisms (e.g., magnetic tape, CD-ROM), the agency and NARA will mutually agree on the most appropriate medium for transfer of the records to the National Archives and will select the appropriate files for FTP transfer. Several important factors may limit the use of FTP as a transfer method, including the number of records, record file size, and available bandwidth. NARA will retain approval for appropriateness of FTP as the selected mechanism for each scheduled records transfer based on certain criteria (file size, FTP transfer rate, record classification, etc.). Agencies interested in sending electronic records scheduled for transfer to NARA through FTP must contact NARA's Electronic and Special Media Records Services Division (NWME), 8601 Adelphi Rd., College Park, MD 20740-6001 or by email to [cer@nara.gov](mailto:cer@nara.gov) to initiate the transfer discussions.

(iv) Each permanent electronic records transfer must be preceded with a signed Agreement to Transfer Records to the National Archives of the United States (Standard Form 258) sent to the Office of Records Services—Washington, DC (NWME), 8601 Adelphi Road, College Park, MD 20740-6001.

(d) *Formats.* The agency may not transfer to the National Archives electronic records that are in a format dependent on specific hardware and/or software. The records shall be written in ASCII or EBCDIC with all control characters and other non-data characters removed (except as specified in paragraphs (d) (1), (2), and (3) of this section). The records must not be compressed unless NARA has approved the transfer in the compressed form in advance. In such cases, NARA may require the agency to provide the software to decompress the records.

(1) *Data files and databases.* Data files and databases shall be transferred to the National Archives as flat files or as rectangular tables; i.e., as two-dimensional arrays, lists, or tables. All "records" (within the context of the computer program, as opposed to a Federal record) or "tuples," i.e., ordered collections of data items, within a file or table should have the same

logical format. Each data element within a record should contain only one data value. A record should not contain nested repeating groups of data items. The file should not contain extraneous control characters, except record length indicators for variable length records, or marks delimiting a data element, field, record, or file. If records or data elements in different files need to be linked or combined, then each record must contain one or more data elements that constitute primary and/or foreign keys enabling valid linkages between the related records in separate files.

(2) *Textual documents.* Electronic textual documents shall be transferred as plain ASCII files; however, such files may contain Standard Generalized Markup Language (SGML) tags.

(3) *Digital spatial data files.* Digital spatial data files shall be transferred to NARA in accordance with the Spatial Data Transfer Standard (SDTS) as defined in the Federal Information Processing Standard 173-1 (June 10, 1994) which is incorporated by reference. Digital geospatial data files created on systems procured prior to February 1994 which do not have a SDTS capability are exempt from this requirement. Agencies should consult with NARA for guidance on transferring noncompliant digital geospatial data files created between February 1, 1994 and the effective date of this paragraph. The standard cited in this paragraph is available from the National Technical Information Service, Department of Commerce, Springfield, VA 22161. When ordering, cite FIPSPUB173-1, Spatial Data Transfer Standard (SDTS). This standard is also available for inspection at the Office of the Federal Register, 800 North Capitol Street, NW., Suite 700, Washington, D.C. This incorporation by reference was approved by the Director of the Federal Register in accordance with 5 U.S.C. 552(a) and 1 CFR part 51. These materials are incorporated by reference as they exist on the date of approval and a notice of any change in these materials will be published in the FEDERAL REGISTER.

(4) *Other categories of electronic records.* Agencies should identify any foreseeable problems in the possible

transfer of potentially permanent electronic records in accordance with paragraphs (d) (1), (2), and (3) of this section at the time the records are scheduled. Special transfer requirements agreed upon by NARA and the agency shall be included in the disposition instructions.

(5) *NARA consultation.* The agency shall consult with NARA for guidance on the transfer of types of electronic records other than those prescribed in paragraphs (d) (1), (2), and (3) of this section.

(e) *Documentation.* Documentation adequate to identify, service and interpret electronic records that have been designated for preservation by NARA shall be transferred with the records. This documentation shall include completed NARA Form 14097, Technical Description for Transfer of Electronic Records, and a completed NARA Form 14028, Information System Description Form, or their equivalents. Where possible, agencies should submit required documentation in an electronic form that conforms to the provisions of this section.

(1) *Data files.* Documentation for data files and data bases must include record layouts, data element definitions, and code translation tables (codebooks) for coded data. Data element definitions, codes used to represent data values and interpretations of these codes must match the actual format and codes as transferred.

(2) *Digital spatial data files.* Digital spatial data files shall include the documentation specified in paragraph (e)(1) of this section. In addition, documentation for digital spatial data files may include metadata that conforms to the Federal Geographic Data Committee's Content Standards for Digital Geospatial Metadata, as specified in Executive Order 12906 of April 11, 1994 (3 CFR, 1995 Comp., p. 882).

(3) *Documents containing SGML tags.* Documentation for electronic files containing textual documents with SGML tags shall include a table for interpreting the SGML tags, when appropriate.

(f) *Incorporation by reference.* The following publications cited in this section are available from the American National Standards Institute (ANSI),

25 West 43rd Street, 4th floor, New York NY 10036 or electronically at <http://www.ansi.org/>. All these standards are also available for inspection at the Office of the Federal Register, 800 North Capitol Street, NW, Suite 700, Washington, D.C. This incorporation by reference was approved by the Director of the Federal Register in accordance with 5 U.S.C. 552(a) and 1 CFR part 51. These materials are incorporated by reference as they exist on the date of approval and a notice of any change in these materials will be published in the FEDERAL REGISTER.

ANSI X3.39-1986, American National Standard: Recorded Magnetic Tape for Information Interchange (1600 CPI, PE).

ANSI X3.54-1986, American National Standard: Recorded Magnetic Tape for Information Interchange (6250 CPI, Group Coded Recording).

ANSI X3.180-1990, American National Standard: Magnetic Tape and Cartridge for Information Interchange—18-Track, Parallel, ½ inch (12.65 mm), 37871 cpi (1491 cpmm), Group-Coded—Requirements for Recording.

ANSI/NISO/ISO 9660-1990, American National Standard for Volume and File Structure of CD-ROM for Information Exchange.

ISO/IEC 15307:1997, First edition, December 1, 1997, Information technology—Data interchange on 12.7 mm 128-track magnetic tape cartridges—DLT 4 format.

ISO/IEC 15896:1999, First edition, December 15, 1999, Information technology—Data interchange on 12.7 mm 208-track magnetic tape cartridges—DLT 5 format.

ISO/IEC 16382:2000, First edition, May 15, 2000, Information technology—Data interchange on 12.7 mm 208-track magnetic tape cartridges—DLT 6 format.

[62 FR 54584, Oct. 21, 1997, as amended at 66 FR 27027, May 16, 2001; 67 FR 79518, Dec. 30, 2002]

**§ 1228.272 Transfer of records to the National Archives of the United States.**

(a) *Policy.* (1) Federal records will be transferred to NARA's legal custody into the National Archives of the United States only if they are listed as permanent on an SF 115, Request for

Records Disposition Authority, approved by NARA since May 14, 1973, or if they are accretions (continuations of series already accessioned) to holdings of the National Archives. Transfers are initiated by submission of an SF 258, Agreement to Transfer Records to the National Archives of the United States.

(2) Each SF 258 must relate to a specific records series, as identified on the SF 115, Request for Records Disposition Authority, in accumulations of one or more consecutive years.

(b) *Initiation of request to transfer.* (1) NARA will provide the SF 258 for records scheduled for immediate transfer on an SF 115 approved after September 30, 1987. NARA will send the SF 258 to the agency with the approved SF 115. The agency will sign and return the SF 258 to the address indicated on the form.

(2) *Future transfers of series in agency space.* Sixty days before the scheduled date of transfer to the National Archives of the United States, the transferring agency must submit an SF 258 to the Office of Records Services—Washington, DC (NWMD), 8601 Adelphi Road, College Park, MD 20740-6001, or to the appropriate Regional Records Services facility if so provided on the SF 115. NARA will determine whether specified restrictions are acceptable and whether adequate space and equipment are available.

(3) *Future transfers of series in Federal Records Centers.* NARA will initiate the SF 258 and send it to the agency 90 days before the scheduled transfer date. The agency shall approve or disapprove the SF 258 and send it to the address indicated on the form 60 days before the scheduled transfer date.

(c) *Physical and legal transfer.* The Office of Records Services—Washington, DC (NWMD), will provide shipping or delivery instructions to the agency or Federal Records Center. Legal custody of the records passes to NARA when the NARA official signs the SF 258 acknowledging receipt of the records.

[52 FR 34134, Sept. 9, 1987. Redesignated at 55 FR 27433, July 2, 1990, as amended at 57 FR 22432, 22434, May 28, 1992; 63 FR 35829, July 1, 1998; 64 FR 67668, Dec. 2, 1999; 66 FR 27027, May 16, 2001]

#### § 1228.274 Restrictions on transferred records.

(a) *General.* Before records are transferred to the National Archives, the head of an agency may state in writing restrictions that appear to him or her to be necessary or desirable in the public interest on the use or examination of records. The head of an agency must, however, justify and cite the statute or Freedom of Information Act exemption (5 U.S.C. 552(b)) that authorizes placing restrictions on the use or examination of records being considered for transfer. If the Archivist agrees, restrictions will be placed on the records.

(b) *Records less than 30 years old.* Unless required by law, the Archivist will not remove or relax restrictions placed upon records less than 30 years old without the concurrence in writing of the head of the agency from which the material was transferred or of his or her successor, if any. If the transferring agency has been terminated and there is no successor in function, the Archivist is authorized to relax, remove or impose restrictions in the public interest.

(c) *Records 30 or more years old.* After the records have been in existence for 30 years or more, statutory or other restrictions referred to in this section shall expire unless the Archivist determines, after consulting with the head of the transferring agency, that the restrictions shall remain in force for a longer period. Such restrictions may be extended by the Archivist beyond 30 years only for reasons consistent with standards established in relevant statutory law, including the Freedom of Information Act (5 U.S.C. 552). Restrictions are systematically extended beyond 30 years where agencies advise NARA on the SF 258 that a particular category of records requires such protection. NARA has identified specific categories of records, including classified information and information that would invade the privacy of an individual, which may require extended protection beyond 30 years. See 36 CFR part 1256.

[57 FR 22434, May 28, 1992]

**§ 1228.276**

**§ 1228.276 Records subject to the Privacy Act of 1974.**

For records constituting systems of records subject to the Privacy Act of 1974 (5 U.S.C. 552a), the agency shall attach to the SF 258 the most recent agency Privacy Act system notice covering the records.

[57 FR 22434, May 28, 1992]

**§ 1228.278 Release of equipment.**

Equipment received with the transfer of records to the National Archives will, when emptied, normally be retained by NARA or disposed of in accordance with applicable excess property regulations, unless the transferring agency requests its return.

[42 FR 57316, Nov. 2, 1977. Redesignated at 50 FR 15723, Apr. 19, 1985, and 55 FR 27433, July 2, 1990]

**§ 1228.280 Use of records transferred to the National Archives.**

(a) In accordance with 44 U.S.C. 2108, restrictions lawfully imposed on the use of transferred records will be observed and enforced by NARA to the extent to which they do not violate 5 U.S.C. 552. The regulations in subchapters B and C of this title, insofar as they relate to the use of records in the National Archives of the United States apply to official use of the records by Federal agencies as well as to the public.

(b) In instances of demonstrated need, and subject to any restrictions on their use, records deposited in the National Archives may be borrowed for official use outside the building in which they are housed by Federal agen-

**36 CFR Ch. XII (7-1-03 Edition)**

cies and the Congress, subject to the following conditions:

(1) Documents of high intrinsic value shall not be removed from the building in which they are housed except with the written approval of the Archivist;

(2) Records will not be loaned to enable agencies to answer routine reference inquiries from other agencies or the public;

(3) Records in fragile condition, or otherwise deteriorated to an extent that further handling will endanger them, will not be loaned;

(4) Each official who borrows records shall provide a receipt for them at the time they are delivered and shall be responsible for their prompt return upon the expiration of the loan period specified by NARA; and

(5) Each official who borrows computer magnetic tapes shall assume responsibility for proper care and handling of the tapes.

[42 FR 57316, Nov. 2, 1977. Redesignated at 50 FR 15723, Apr. 19, 1985, and amended at 55 FR 26935, June 28, 1985. Redesignated at 55 FR 27433, July 2, 1990, as amended at 57 FR 22434, May 28, 1992]

**§ 1228.282 Disposal clearances.**

No records of a Federal agency still in existence will be disposed of by NARA except with the written concurrence of the agency concerned or as authorized on Standard Form 258, Agreement to Transfer Records to the National Archives of the United States.

[66 FR 27027, May 16, 2001]

APPENDIX A TO PART 1228—MINIMUM SECURITY STANDARDS FOR LEVEL III FEDERAL FACILITIES



Reproduced from Section 2.3 (pp. 2-6 through 2-9) of  
U.S. Department of Justice, United States Marshals Service report  
*Vulnerability Assessment of Federal Facilities*

**RECOMMENDED STANDARDS CHART**

<b>PERIMETER SECURITY</b>	<b>LEVEL III</b>
<b><i>PARKING</i></b>	
CONTROL OF FACILITY PARKING	●
CONTROL OF ADJACENT PARKING	▲
AVOID LEASES WHERE PARKING CANNOT BE CONTROLLED	▲
LEASES SHOULD PROVIDE SECURITY CONTROL FOR ADJACENT PARKING	▲
POST SIGNS AND ARRANGE FOR TOWING UNAUTHORIZED VEHICLES	●
ID SYSTEM AND PROCEDURES FOR AUTHORIZED PARKING (PLACARD, DECAL, CARD KEY, ETC.)	●
ADEQUATE LIGHTING FOR PARKING AREAS	●
<b><i>CLOSED CIRCUIT TELEVISION (CCTV) MONITORING</i></b>	
CCTV SURVEILLANCE CAMERAS WITH TIME LAPSE VIDEO RECORDING	○
POST SIGNS ADVISING OF 24 HOUR VIDEO SURVEILLANCE	○
<b><i>LIGHTING</i></b>	
LIGHTING WITH EMERGENCY POWER BACKUP	●
<b><i>PHYSICAL BARRIERS</i></b>	
EXTEND PHYSICAL PERIMETER WITH BARRIERS (CONCRETE AND/OR STEEL COMPOSITION)	▲
PARKING BARRIERS	▲
<b>ENTRY SECURITY</b>	<b>LEVEL III</b>
<b><i>RECEIVING/SHIPPING</i></b>	
REVIEW RECEIVING/SHIPPING PROCEDURES (CURRENT)	●
IMPLEMENT RECEIVING/SHIPPING PROCEDURES (MODIFIED)	●

● REQUIRED      ○ RECOMMENDED      ▲ DESIRABLE

<b>ENTRY SECURITY, cont.</b>	<b>LEVEL III</b>
<b><i>ACCESS CONTROL</i></b>	
EVALUATE FACILITY FOR SECURITY GUARD REQUIREMENTS	●
SECURITY GUARD PATROL	○
INTRUSION DETECTION SYSTEM WITH CENTRAL MONITORING CAPABILITY	●
UPGRADE TO CURRENT LIFE SAFETY STANDARDS (FIRE DETECTION, FIRE SUPPRESSION SYSTEMS, ETC.)	●
<b><i>ENTRANCES/EXITS</i></b>	
X-RAY & MAGNETOMETER AT PUBLIC ENTRANCES	○
REQUIRE X-RAY SCREENING OF ALL MAIL/PACKAGES	○
HIGH SECURITY LOCKS	●
<b>INTERIOR SECURITY</b>	<b>LEVEL III</b>
<b><i>EMPLOYEE/VISITOR IDENTIFICATION</i></b>	
AGENCY PHOTO ID FOR ALL PERSONNEL DISPLAYED AT ALL TIMES	○
VISITOR CONTROL/SCREENING SYSTEM	●
VISITOR IDENTIFICATION ACCOUNTABILITY SYSTEM	○
ESTABLISH ID ISSUING AUTHORITY	○
<b><i>UTILITIES</i></b>	
PREVENT UNAUTHORIZED ACCESS TO UTILITY AREAS	●
PROVIDE EMERGENCY POWER TO CRITICAL SYSTEMS (ALARM SYSTEMS, RADIO COMMUNICATIONS, COMPUTER FACILITIES, ETC.)	●
<b><i>OCCUPANT EMERGENCY PLANS</i></b>	
EXAMINE OCCUPANT EMERGENCY PLANS (OEP) AND CONTINGENCY PROCEDURES BASED ON THREATS	●
OEPs IN PLACE, UPDATED ANNUALLY, PERIODIC TESTING EXERCISE	●
ASSIGN & TRAIN OEP OFFICIALS (ASSIGNMENT BASED ON LARGEST TENANT IN FACILITY)	●
ANNUAL TENANT TRAINING	●

● REQUIRED      ○ RECOMMENDED      ▲ DESIRABLE

INTERIOR SECURITY, cont.	LEVEL III
<b><i>DAYCARE CENTERS</i></b>	
COMPARE FEASIBILITY OF LOCATING DAYCARE IN OUTSIDE LOCATIONS	●
EVALUATE WHETHER TO LOCATE DAYCARE FACILITIES IN BUILDINGS WITH HIGH THREAT ACTIVITIES	●
<b>SECURITY PLANNING</b>	<b>LEVEL III</b>
<b><i>INTELLIGENCE SHARING</i></b>	
ESTABLISH LAW ENFORCEMENT AGENCY/SECURITY LIAISONS	●
REVIEW/ESTABLISH PROCEDURE FOR INTELLIGENCE RECEIPT/DISSEMINATION	●
ESTABLISH UNIFORM SECURITY/THREAT NOMENCLATURE	●
<b><i>TRAINING</i></b>	
CONDUCT ANNUAL SECURITY AWARENESS TRAINING	●
ESTABLISH STANDARDIZED UNARMED GUARD QUALIFICATIONS/ TRAINING REQUIREMENTS	●
ESTABLISH STANDARDIZED ARMED GUARD QUALIFICATIONS/ TRAINING REQUIREMENTS	●
<b><i>TENANT ASSIGNMENT</i></b>	
CO-LOCATE AGENCIES WITH SIMILAR SECURITY NEEDS	▲
DO NOT CO-LOCATE HIGH/LOW RISK AGENCIES	▲
<b><i>ADMINISTRATIVE PROCEDURES</i></b>	
ESTABLISH FLEXIBLE WORK SCHEDULE IN HIGH THREAT/ HIGH RISK AREAS TO MINIMIZE EMPLOYEE VULNERABILITY TO CRIMINAL ACTIVITY	▲
ARRANGE FOR EMPLOYEE PARKING IN/NEAR BUILDING AFTER NORMAL WORK HOURS	○
CONDUCT BACKGROUND SECURITY CHECKS AND/OR ESTABLISH SECURITY CONTROL PROCEDURES FOR SERVICE CONTRACT PERSONNEL	●
<b><i>CONSTRUCTION/RENOVATION</i></b>	
INSTALL MYLAR FILM ON ALL EXTERIOR WINDOWS (SHATTER PROTECTION)	○
REVIEW CURRENT PROJECTS FOR BLAST STANDARDS	●
REVIEW/ESTABLISH UNIFORM STANDARDS FOR CONSTRUCTION	●
REVIEW/ESTABLISH NEW DESIGN STANDARD FOR BLAST RESISTANCE	●
ESTABLISH STREET SET-BACK FOR NEW CONSTRUCTION	○
● REQUIRED      ○ RECOMMENDED      ▲ DESIRABLE	

Reproduced from Appendix B, *Details of Recommended Security Standards*  
 U.S. Department of Justice, United States Marshals Service report  
*Vulnerability Assessment of Federal Facilities*

### B.1 Perimeter Security

<b>Parking</b>	
<b>Term</b>	<b>Definition/Description</b>
<b>CONTROL OF FACILITY PARKING</b>	Access to government parking should be limited where possible to government vehicles and personnel. At a minimum, authorized parking spaces and vehicles should be assigned and identified.
<b>CONTROL OF ADJACENT PARKING</b>	Where feasible, parking areas adjacent to federal space should also be controlled to reduce the potential for threats against Federal facilities and employee exposure to criminal activity.
<b>AVOID LEASES WHERE PARKING CANNOT BE CONTROLLED</b>	Avoid leasing facilities where parking cannot be controlled. If necessary, relocate offices to facilities that do provide added security through regulated parking.
<b>LEASE SHOULD PROVIDE CONTROL FOR ADJACENT PARKING</b>	Endeavor to negotiate guard services as part of lease.
<b>POST SIGNS AND ARRANGE FOR TOWING UNAUTHORIZED VEHICLES</b>	Procedures should be established and implemented to alert the public to towing policies, and the removal of unauthorized vehicles.
<b>ID SYSTEM AND PROCEDURES FOR AUTHORIZED PARKING</b>	Procedures should be established for identifying vehicles and corresponding parking spaces (placard, decal, card key, etc.).
<b>ADEQUATE LIGHTING FOR PARKING AREAS</b>	Effective lighting provides added safety for employees and deters illegal or threatening activities.

<b>Closed Circuit Television (CCTV) Monitoring</b>	
<b>Term</b>	<b>Definition/Description</b>
<b>CCTV SURVEILLANCE CAMERAS WITH TIME LAPSE VIDEO RECORDING</b>	Twenty-four hour CCTV surveillance and recording is desirable at all locations as a deterrent. Requirements will depend on assessment of the security level for each facility. Time-lapse video recordings are also highly valuable as a source of evidence and investigative leads
<b>POST SIGNS ADVISING OF 24 HOUR VIDEO SURVEILLANCE</b>	Warning signs advising of twenty-four hour surveillance act as a deterrent in protecting employees and facilities.

<b>Lighting</b>	
<b>Term</b>	<b>Definition/Description</b>
<b>LIGHTING WITH EMERGENCY POWER BACKUP</b>	Standard safety code requirement in virtually all areas. Provides for safe evacuation of buildings in case of natural disaster, power outage, or criminal/terrorist activity.

<b>Physical Barriers</b>	
<b>Term</b>	<b>Definition/Description</b>
<b>EXTEND PHYSICAL PERIMETER, WITH BARRIERS</b>	This security measure will only be possible in locations where the Government controls the property and where physical constraints are not present. (barriers of concrete and/or steel composition)
<b>PARKING BARRIERS</b>	Desirable to prevent unauthorized vehicle access.

**B.2 Entry Security**

<b>Receiving/Shipping</b>	
<b>Term</b>	<b>Definition/Description</b>
<b>REVIEW RECEIVING/SHIPPING PROCEDURES (CURRENT)</b>	Audit current standards for package entry and suggest ways to enhance security.
<b>IMPLEMENT RECEIVING/SHIPPING PROCEDURES (MODIFIED)</b>	After auditing procedures for receiving/shipping, implement improved procedures for security enhancements.

<b>Access Control</b>	
<b>Term</b>	<b>Definition/Description</b>
<b>EVALUATE FACILITY FOR SECURITY GUARD REQUIREMENTS</b>	If security guards are required, the number of guards at any given time will depend on the size of the facility, the hours of operation, and current risk factors, etc.
<b>SECURITY GUARD PATROL</b>	Desirable for level I and II facilities and may be included as lease option. Level III, IV and V facilities will have security guard patrol based on facility evaluation.
<b>INTRUSION DETECTION SYSTEM WITH CENTRAL MONITORING CAPABILITY</b>	Desirable in Level I facilities, based on evaluation for Level II facilities, and required for Levels III, IV and V.
<b>UPGRADE TO CURRENT LIFE SAFETY STANDARDS</b>	Required for all facilities as part of GSA design requirements, (e.g. fire detection, fire suppression systems, etc.)

<b>Entrances/Exits</b>	
<b>Term</b>	<b>Definition/Description</b>
<b>X-RAY AND MAGNETOMETER AT PUBLIC ENTRANCES</b>	May be impractical for Level I and II facilities. Level III and IV evaluations would focus on tenant agencies, public interface, and feasibility. Required for Level V.
<b>REQUIRE X-RAY SCREENING OF ALL MAIL/PACKAGES</b>	All packages entering buliding should be subject to x-ray screening and/or visual inspection.
<b>HIGH SECURITY LOCKS</b>	Any exterior entrance should have a high security lock as determined by GSA specifications and/or agency requirements.

**B.3 Interior Security**

<b>Employee/Visitor Identification</b>	
<b>Term</b>	<b>Definition/Description</b>
<b>AGENCY PHOTO ID FOR ALL PERSONNEL DISPLAYED AT ALL TIMES</b>	May not be required in smaller facilities.

<b>Employee/Visitor Identification</b>	
<b>Term</b>	<b>Definition/Description</b>
<b>VISITOR CONTROL/SECURITY SYSTEM</b>	Visitors should be readily apparent in Level I facilities. Other facilities may ask visitors to sign-in with a receptionist or guard, or require an escort, or formal identification/badge.
<b>VISITOR ID ACCOUNTABILITY SYSTEM</b>	Stringent methods of control over visitor badges will ensure that visitors wearing badges have been screened and are authorized to be at the facility during the appropriate time frame.
<b>ESTABLISH ID ISSUING AUTHORITY</b>	Develop procedures and establish authority for issuing employee and visitor IDs.

<b>Utilities</b>	
<b>Term</b>	<b>Definition/Description</b>
<b>PREVENT UNAUTHORIZED ACCESS TO UTILITY AREAS</b>	Smaller facilities may not have control over utility access, or locations of utility areas. Where possible, assure that utility areas are secure and that only authorized personnel can gain entry.
<b>PROVIDE EMERGENCY POWER TO CRITICAL SYSTEMS</b>	Tenant agency is responsible for determining which computer and communication systems require back-up power. All alarm systems, CCTV monitoring devices, fire detection systems, entry control devices, etc. require emergency power sources. (ALARM SYSTEMS, RADIO COMMUNICATIONS, COMPUTER FACILITIES, ETC.)

<b>Occupant Emergency Plans</b>	
<b>Term</b>	<b>Definition/Description</b>
<b>EXAMINE OCCUPANT EMERGENCY PLAN (OEP) AND CONTINGENCY PROCEDURES BASED ON THREATS</b>	Review and update current OEP procedures for thoroughness. OEPs should reflect the current security climate.

<b>Occupant Emergency Plans</b>	
<b>Term</b>	<b>Definition/Description</b>
<b>ASSIGN AND TRAIN OEP OFFICIALS</b>	Assignment based on GSA requirement that largest tenant in facility maintain OEP responsibility. Officials should be assigned, trained and a contingency plan established to provide for the possible absence of OEP officials in the event of emergency activation of the OEP.
<b>ANNUAL TENANT TRAINING</b>	All tenants should be aware of their individual responsibilities in an emergency situation.

<b>Day Care Center</b>	
<b>Term</b>	<b>Definition/Description</b>
<b>RE-EVALUATE CURRENT SECURITY AND SAFETY STANDARDS</b>	Conduct a thorough review of security and safety standards.
<b>ASSESS FEASIBILITY OF LOCATING DAY CARE WITHIN FEDERAL FACILITY</b>	If a facility is being considered for a day care center, an evaluation should be made based on the risk factors associated with tenants and the location of the facility.

**B.4 Security Planning**

<b>Intelligence Sharing</b>	
<b>Term</b>	<b>Definition/Description</b>
<b>ESTABLISH LAW ENFORCEMENT AGENCY/SECURITY LIAISONS</b>	Intelligence sharing between law enforcement agencies and security organizations should be established in order to facilitate the accurate flow of timely and relevant information between appropriate government agencies. Agencies involved in providing security must be part of the complete intelligence process.
<b>REVIEW/ESTABLISH PROCEDURES FOR INTELLIGENCE RECEIPT/DISSEMINATION</b>	Determine what procedures exist to ensure timely delivery of critical intelligence. Review and improve procedures to alert agencies and specific targets of criminal/terrorist threats. Establish standard administrative procedures for response to incoming alerts. Review flow of information for effectiveness and time critical dissemination.



<b>Intelligence Sharing</b>	
<b>Term</b>	<b>Definition/Description</b>
<b>ESTABLISH UNIFORM SECURITY/THREAT NOMENCLATURE</b>	To facilitate communication, standardized terminology for Alert Levels should be implemented. ( <u>Normal, Low, Moderate, and High - As recommended by Security Standards Committee</u> )

<b>Training</b>	
<b>Term</b>	<b>Definition/Description</b>
<b>CONDUCT ANNUAL SECURITY AWARENESS TRAINING</b>	Provide security awareness training for all tenants. At a minimum, self-study programs utilizing videos, and literature, etc. should be implemented. These materials should provide up-to-date information covering security practices, employee security awareness, and personal safety, etc.
<b>ESTABLISH STANDARDIZED ARMED AND UNARMED GUARD QUALIFICATIONS/ TRAINING REQUIREMENTS</b>	Requirements for these positions should be standardized government wide.

<b>Tenant Assignment</b>	
<b>Term</b>	<b>Definition/Description</b>
<b>CO-LOCATE AGENCIES WITH SIMILAR SECURITY NEEDS</b>	To capitalize on efficiencies and economies, agencies with like security requirements should be located in the same facility if possible.
<b>DO NOT CO-LOCATE HIGH/LOW RISK AGENCIES</b>	Low risk agencies should not take on additional risk by being located with high risk agencies.

<b>Administrative Procedures</b>	
<b>Term</b>	<b>Definition/Description</b>
<b>ESTABLISH FLEXIBLE WORK SCHEDULE IN HIGH THREAT/ HIGH RISK AREA TO MINIMIZE EMPLOYEE VULNERABILITY TO CRIMINAL ACTIVITY.</b>	Flexible work schedules can enhance employee safety by staggering reporting and departure times. As an example flexible schedules might enable employees to park closer to the facility by reducing the demand for parking at peak times of the day.
<b>ARRANGE FOR EMPLOYEE PARKING IN/NEAR BUILDING AFTER NORMAL WORK HOURS</b>	Minimize exposure to criminal activity by allowing employees to park at or inside the building.
<b>CONDUCT BACKGROUND SECURITY CHECKS AND/OR ESTABLISH SECURITY CONTROL PROCEDURES FOR SERVICE CONTRACT PERSONNEL</b>	Establish procedures to ensure security where private contract personnel are concerned. Procedures may be as simple as observation or could include sign-in/escort. Frequent visitors may necessitate a background check with contractor ID issued.

<b>Construction/Renovation</b>	
<b>Term</b>	<b>Definition/Description</b>
<b>INSTALL MYLAR FILM ON ALL EXTERIOR WINDOWS (SHATTER PROTECTION)</b>	Application of shatter resistant material to protect personnel and citizens from the hazards of flying glass as a result of impact or explosion.
<b>REVIEW CURRENT PROJECTS FOR BLAST STANDARDS</b>	Design and construction projects should be reviewed if possible, to incorporate current technology and blast standards. Immediate review of ongoing projects may generate savings in the implementation of upgrading to higher blast standards prior to completion of construction.
<b>REVIEW/ESTABLISH UNIFORM STANDARDS FOR CONSTRUCTION</b>	Review, establish, and implement uniform construction standards as it relates to security considerations.

Construction/Renovation	
Term	Definition/Description
<b>REVIEW/ESTABLISH NEW DESIGN STANDARD FOR BLAST RESISTANCE</b>	In smaller facilities or those that lease space, control over design standards may not be possible. However, future site selections should attempt to locate in facilities that do meet standards. New construction of government controlled facilities should review, establish, and implement new design standards for blast resistance.
<b>ESTABLISH STREET SET-BACK FOR NEW CONSTRUCTION</b>	Every foot between a potential bomb and a building will dramatically reduce damage and increase the survival rate. Street set-back is always desirable, but should be used in conjunction with barriers in Level IV and V facilities.

Excerpted from Appendix C, *Classification Table*  
 U.S. Department of Justice, United States Marshals Service report  
*Vulnerability Assessment of Federal Facilities*

LEVEL	TYPICAL LOCATION
III	Agency Mix: Government Records

[64 FR 67648, Dec. 2, 1999]

APPENDIX B TO PART 1228—ALTER-NATIVE CERTIFIED FIRE-SAFETY DETECTION AND SUPPRESSION SYSTEM(S)

1. *General.* This Appendix B contains information on the Fire-safety Detection and Suppression System(s) tested by NARA through independent live fire testing that are certified to meet the requirement in §1228.230(s) for storage of Federal Records. Use of a system specified in this appendix is optional. A facility may choose to have an alternate fire-safety detection and suppression system approved under §1228.242.

2. *Specifications for NARA facilities using 15 foot high records storage.* NARA fire-safety systems that incorporate all components specified in paragraphs 2.a. through o. of this appendix have been tested and certified to meet the requirements in §1228.230(s) for an acceptable fire-safety detection and suppression system for storage of Federal records.

a. The records storage height must not exceed the nominal 15 feet (+/-3 inches) records storage height.

b. All records storage and adjoining areas must be protected by automatic wet-pipe sprinklers. Automatic sprinklers are specified herein because they provide the most effective fire protection for high piled storage of paper records on open type shelving.

c. The sprinkler system must be rated at no higher than 285 degrees Fahrenheit utilizing quick response (QR) fire sprinkler heads and designed by a licensed fire protection engineer to provide the specified density for the most remote 1,500 square feet of floor area at the most remote sprinkler head in accordance with NFPA 13 (1996), Standard for the Installation of Sprinkler Systems. For facilities with roofs rated at 15 minutes or greater, provide 1/2" QR sprinklers rated at no higher than 285 degrees Fahrenheit designed to deliver a density of 0.30 gpm per square foot. For unrated roofs, provide 0.64" QR "large drop" sprinklers rated at no higher than 285 degrees Fahrenheit. For facilities using 7 or 8 shelf track files, use QR sprinklers rated at no higher than 285 degrees Fahrenheit. For new construction and replacement sprinklers, NARA recommends that the sprinklers be rated at 165 degrees

Fahrenheit. Installation of the sprinkler system must be in accordance with NFPA 13 (1996), Standard for the Installation of Sprinkler Systems.

d. Maximum spacing of the sprinkler heads must be on a 10-foot grid and the positioning of the heads must provide complete, unobstructed coverage, with a clearance of not less than 18 inches from the top of the highest stored materials.

e. The sprinkler system must be equipped with a water-flow alarm connected to an audible alarm within the facility and to a continuously staffed fire department or an Underwriters Laboratory approved central monitoring station (see UL 827, Central-Station Alarm Services (April 23, 1999)) with responsibility for immediate response.

f. A manual fire alarm system must be provided with a Underwriters Laboratory approved (grade A) central monitoring station service or other automatic means of notifying the municipal fire department. A manual alarm pull station must be located adjacent to each exit. Supplemental manual alarm stations are permitted within the records storage areas.

g. All water cutoff valves in the sprinkler system must be equipped with automatic closure alarm (tamper alarm) connected to a continuously staffed station, with responsibility for immediate response. If the sprinkler water cutoff valve is located in an area used by the public, in addition to the tamper alarm, the valves must be provided with frangible (easily broken) padlocks.

h. A dependable water supply free of interruption must be provided including a continuous site fire loop connected to the water main and sized to support the facility with only one portion of the fire loop operational. This normally requires a backup supply system having sufficient pressure and capacity to meet both fire hose and sprinkler requirements for 2-hours. A fire pump connected to an emergency power source must be provided in accordance with NFPA 20 (1996), Standard for the Installation of Centrifugal Fire Pumps, when adequate water pressure is not assured. In the event that public water mains are not able to supply adequate volumes of water to the site, on-site water storage must be provided.

i. Interior fire hose stations equipped with a 1½ inch diameter hose may be provided in the records storage areas if required by the local fire department, enabling any point in the records storage area to be reached by a 50-foot hose stream from a 100-foot hose lay. If provided, these cabinets must be marked "For Fire Department Use Only."

j. Where fire hose cabinets are not required, fire department hose outlets must be provided at each floor landing in the building core or stair shaft. Hose outlets must have an easily removable adapter and cap. Threads and valves must be compatible with

the local fire department's equipment. Spacing must be so that any point in the record storage area can be reached with a 50-foot hose stream from a 100-foot hose lay.

k. In addition to the designed sprinkler flow demand, 500 gpm must be provided for hose stream demand. The hose stream demand must be calculated into the system at the base of the main sprinkler riser.

l. Fire hydrants must be located within 250 feet of each exterior entrance or other access to the records storage facility that could be used by firefighters. Each required hydrant must provide a minimum flow capacity of 500 gpm at 20 psi. All hydrants must be at least 50 feet away from the building walls and adjacent to a roadway usable by fire apparatus. Fire hydrants must have at least two, 2½ inch hose outlets and a pumper connection. All threads must be compatible with local standards.

m. Portable water-type fire extinguishers (2½ gallon stored pressure type) must be provided at each fire alarm striking station. The minimum number and locations of fire extinguishers must be as required by NFPA 10 (1994), Standard for Portable Fire Extinguishers.

n. Single level catwalks without automatic sprinklers installed underneath may be provided in the service aisles if the edges of all files in the front boxes above the catwalks are stored perpendicular to the aisle (to minimize files exfoliation in a fire). Where provided, the walking surface of the catwalks must be of expanded metal at least .09-inch thickness with a 2-inch mesh length. The surface opening ratio must be equal or greater than 0.75. The sprinkler water demand for protection over bays with catwalks where records above the catwalks are not perpendicular to the aisles must be calculated hydraulically to give .30 gpm per square foot for the most remote 2,000 square feet.

[64 FR 67660, Dec. 2, 1999]

## PART 1230—MICROGRAPHIC RECORDS MANAGEMENT

### Subpart A—General

Sec.

1230.1 What does this part cover?

1230.2 What is the authority for this part?

1230.3 Publications incorporated by reference.

1230.4 Definitions.

### Subpart B—Program Requirements

1230.7 What must agencies do to manage microform records?

**Subpart C—Microfilming Standards**

- 1230.10 Do agencies need to request NARA approval for the disposition of all microform and source records?
- 1230.12 What are the steps to be followed in filming records?
- 1230.14 What are the filming requirements for permanent and unscheduled records?
- 1230.16 What are the film and image requirements for temporary records, duplicates, and user copies?

**Subpart D—Storage, Use and Disposition Standards of Microform Records**

- 1230.20 How should microform records be stored?
- 1230.22 What are NARA inspection requirements for permanent and unscheduled microform records?
- 1230.24 What are NARA inspection requirements for temporary microform records?
- 1230.26 What are the use restrictions for permanent and unscheduled microform records?
- 1230.28 What must agencies do to send permanent microform records to a records storage facility?
- 1230.30 How do agencies transfer permanent microform records to the legal custody of the National Archives?

**Subpart E—Centralized Micrographic Services**

- 1230.50 What micrographic services are available from NARA?

AUTHORITY: 44 U.S.C. 2907, 3302 and 3312.

SOURCE: 67 FR 31693, May 9, 2002; 67 FR 39473, June 7, 2002, unless otherwise noted.

**Subpart A—General****§ 1230.1 What does this part cover?**

This part covers the standards and procedures for using micrographic technology to create, use, store, inspect, retrieve, preserve, and dispose of Federal records. § 1230.2 What is the authority for this part?

44 U.S.C. chapters 29 and 33, authorize the Archivist of the United States to:

- (a) Establish standards for copying records by photographic and microphotographic means;
- (b) Establish standards for the creation, storage, use, and disposition of microform records in Federal agencies; and
- (c) Provide centralized microfilming services for Federal agencies.

**§ 1230.2 What is the authority for this part?**

44 U.S.C. chapters 29 and 33, authorize the Archivist of the United States to:

- (a) Establish standards for copying records by photographic and microphotographic means;
- (b) Establish standards for the creation, storage, use, and disposition of microform records in Federal agencies; and
- (c) Provide centralized microfilming services for Federal agencies.

**§ 1230.3 Publications incorporated by reference.**

(a) *General.* The following publications are hereby incorporated by reference into Part 1230. They are available from the issuing organizations at the addresses listed in this section. They may also be examined at the Office of the Federal Register, 800 North Capitol Street NW, suite 700, Washington, DC. This incorporation by reference was approved by the Director of the Federal Register in accordance with 5 U.S.C. 552(a) and 1 CFR Part 51. These materials are incorporated as they exist on the date of approval, and a notice of any change in these materials will be published in the FEDERAL REGISTER.

(b) *American National Standards Institute (ANSI) and International (ISO) standards.* ANSI standards cited in this part are available from the American National Standards Institute, 25 West 43rd St., 4th Floor, New York, NY 10036. The standards can be ordered on line at <http://webstore.ansi.org/ansidocstore/default.asp>.

ISO 10602:1995(E), February 1, 1995, Second edition, Photography—Processed silver-gelatin type black-and-white film—Specifications for stability.

ANSI/PIMA IT9.2-1998, April 15, 1998, American National Standard for Imaging Materials—Photographic Processed Films, Plates, and Papers—Filing Enclosures and Storage Containers.

ANSI/ISO 5.2-1991, ANSI/NAPM IT2.19-1994, February 20, 1995, American National Standard for Photography—Density Measurements—Part 2: Geometric Conditions for Transmission Density.

ANSI/ISO 5-3-1995, ANSI/NAPM IT2.18-1996, March 8, 1996, American National Standard

## § 1230.4

for Photography—Density Measurements—Part 3: Spectral Conditions. ISO 18911: 2000(E), First edition, November 1, 2000, Imaging materials—Processed safety photographic films—Storage practices.

(c) *Association of Information and Image Management (AIIM) Standards.* You may obtain the following standards from the Association of Information and Image Management, 1100 Wayne Avenue, suite 1100, Silver Spring, MD 20910. The standards can be ordered on line at <http://www.aiim.org/>.

ANSI/AIIM MS1—1996, August 8, 1996, Standard Recommended Practice for Alphanumeric Computer-Output Microforms—Operational Practices for Inspection and Quality Control.

ANSI/AIIM MS5—1992, December 21, 1992, Standard for Information and Image Management—Microfiche.

ANSI/AIIM MS14—1996, August 8, 1996, Standard Recommended Practice—Specifications for 16mm and 35mm Roll Microfilm.

ANSI/AIIM MS19—1993, August 18, 1993, Standard Recommended Practice—Identification of Microforms.

ANSI/AIIM MS23—1998, June 2, 1998, Standard Recommended Practice—Production, Inspection, and Quality Assurance of First-Generation, Silver Microforms of Documents.

ANSI/AIIM MS32—1996, February 16, 1996, Standard Recommended Practice—Microrecording of Engineering Source Documents on 35mm Microfilm.

ANSI/AIIM MS41—1996, July 16, 1996, Dimensions of Unitized Microfilm Carriers and Apertures (Aperture, Camera, Copy and Image Cards).

ANSI/AIIM MS43—1998, June 2, 1998, Standard Recommended Practice—Operational Procedures—Inspection and Quality Control of Duplicate Microforms of Documents and From COM.

ANSI/AIIM MS45—1990, January 22, 1990, Recommended Practice for Inspection of Stored Silver-Gelatin Microforms for Evidence of Deterioration.

ANSI/ISO 3334—1991, ANSI/AIIM MS51—1991, May 10, 1991, Micrographics—ISO Resolution Test Chart No. 2—Description and Use.

### § 1230.4 Definitions.

The following definitions apply to this part:

*Archival microfilm.* A photographic film that meets the standards described in § 1230.14 and that is suitable for the preservation of permanent records when stored in accordance with

## 36 CFR Ch. XII (7–1–03 Edition)

§ 1230.20(a). Such film must conform to film designated as LE 500 in ANSI/NAPM IT9.1–1996.

*Background density.* The opacity of the area of the microform not containing information.

*Computer-assisted retrieval (CAR) system.* A records storage and retrieval system, normally microfilm-based, that uses a computer for indexing, automatic markings such as blips or bar codes for identification, and automatic devices for reading those markings and, in some applications, for transporting the film for viewing.

*Computer Output Microfilm (COM).* Microfilm containing data converted and recorded from a computer.

*Facility.* An area used exclusively to make or copy microforms.

*Microfilm.* (1) Raw (unexposed and unprocessed) fine-grain, high resolution photographic film with characteristics that make it suitable for use in micrographics;

(2) The process of recording microimages on film; or

(3) A fine-grain, high resolution photographic film containing microimages.

*Microform.* Any form containing microimages.

*Microimage.* A document such as a page of text or a drawing that is too small to be read without magnification.

*Permanent record.* Permanent record has the meaning specified in § 1220.14 of this chapter.

*Records storage facility.* Records storage facility has the meaning specified in § 1220.14 of this chapter.

*Temporary record.* Temporary record has the meaning specified in § 1220.14 of this chapter.

*Unscheduled record.* Unscheduled record has the meaning specified in § 1220.14 of this chapter.

*Use or work copies.* Duplicates of original film made to be used for reference or for duplication on a recurring or large-scale basis. These are not preservation master copies, which must be stored unused as specified in § 1230.20.

**Subpart B—Program Requirements****§ 1230.7 What must agencies do to manage microform records?**

Federal agencies must manage microform records by taking the following actions:

(a) Assign responsibility for an agencywide program for managing microform records and notify the National Archives and Records Administration (NWM), 8601 Adelphi Rd., College Park, MD 20740-6001 of the name and title of the person assigned the responsibility.

(b) Manage the microform records as part of other records and information resources management programs of the agency.

(c) Include microform records management objectives, responsibilities, and authorities in pertinent agency directives and disseminate them to appropriate officials.

(d) Address records management issues, including disposition, before approving new microform records systems or enhancements to existing systems.

(e) Train the managers and users of microform records.

(f) Develop records schedules covering microform records and finding aids, secure NARA approval, and apply the disposition instructions.

(g) Schedule computerized indexes associated with microform records, such as in a computer-assisted retrieval (CAR) system, in accordance with part 1234 of this chapter.

(h) Review practices used to create and manage microform records periodically to ensure compliance with NARA standards in this part.

**Subpart C—Microfilming Standards****§ 1230.10 Do agencies need to request NARA approval for the disposition of all microform and source records?**

(a) *Permanent or uncheduled records.* Agencies must schedule both source documents (originals) and microforms. NARA must approve the schedule, Standard Form (SF) 115, Request for Records Disposition Authority, in accordance with part 1228 of this chapter

before any records, including source documents, can be destroyed. NARA will not approve the destruction of original records that have intrinsic value, or security classified or otherwise restricted original records that are scheduled as permanent, or original records that are scheduled as permanent and that have other characteristics that would limit the usefulness of microform copies for public reference.

(1) Agencies that comply with the standards in § 1230.14 must include on the SF 115 the following certification: "This certifies that the records described on this form were (or will be) microfilmed in accordance with the standards set forth in 36 CFR part 1230."

(2) Agencies using microfilming methods, materials, and procedures that do not meet the standards in § 1230.14(a) must include on the SF 115 a description of the system and standards used.

(3) When an agency intends to retain the silver original microforms of permanent records and destroy the original records, the agency must certify in writing on the SF 115 that the microform will be stored in compliance with the standards of § 1230.20 and inspected as required by § 1230.22.

(b) *Temporary records.* Agencies do not need to obtain additional NARA approval when destroying scheduled temporary records that have been microfilmed. The same approved retention period for temporary records is applied to microform copies of these records. The original records can be destroyed once microfilm is verified, unless legal requirements prevent their early destruction.

**§ 1230.12 What are the steps to be followed in filming records?**

(a) Ensure that the microforms contain all information shown on the originals and that they can be used for the purposes the original records served.

(b) Arrange, describe, and index the filmed records to permit retrieval of any particular document or component of the records. Title each microform roll or fiche with a titling target or header. For fiche, place the titling information in frame 1 if the information

## § 1230.14

will not fit on the header. At a minimum, titling information must include:

- (1) The title of the records;
- (2) The number or identifier for each unit of film;
- (3) The security classification, if any; and
- (4) The name of the agency and organization the inclusive dates, names, or other data identifying the records to be included on a unit of film.

(c) Add an identification target showing the date of filming. When necessary to give the film copy legal standing, the target must also identify the person who authorized the microfilming. See ANSI/AIIM MS19-1993 for standards for identification targets.

(d) The following formats are mandatory standards for microforms:

(1) *Roll film.* (i) *Source documents.* The formats described in ANSI/AIIM MS14-1996 must be used for microfilming source documents on 16mm and 35mm roll film. A reduction ratio no greater than 1:24 is recommended for typewritten or correspondence types of documents. See ANSI/AIIM MS23-1998 for the appropriate reduction ratio and format for meeting the image quality requirements. When microfilming on 35mm film for aperture card applications, the format dimensions in ANSI/AIIM MS32-1996, Table 1 are mandatory, and the aperture card format "D Aperture" shown in ANSI/AIIM MS41-1996, Figure 1, must be used. The components of the aperture card, including the paper and adhesive, must conform to the requirements of ANSI/PIMA IT9.2-1998. The 35mm film used in the aperture card application must conform to film designated as LE 500 in ANSI/NAPM IT9.1-1996.

(ii) *COM.* Computer output microfilm (COM) generated images must be the simplex mode described in ANSI/AIIM MS14-1996 at an effective ratio of 1:24 or 1:48 depending upon the application.

(2) *Microfiche.* For microfilming source documents or computer generated information (COM) on microfiche, the formats and reduction ratios prescribed in ANSI/AIIM MS5-1992 (R1998) must be used as specified for the size and quality of the documents being filmed. See ANSI/AIIM MS23-1998 for determining the appropriate reduc-

## 36 CFR Ch. XII (7-1-03 Edition)

tion ratio and format for meeting the image quality requirements.

(e) *Index placement.* (1) *Source documents.* When filming original (source) documents, place indexes, registers, or other finding aids, if microfilmed, either in the first frames of the first roll of film or in the last frames of the last roll of film of a series. For microfiche, place them in the last frames of the last microfiche or microfilm jacket of a series.

(2) *COM.* Place indexes on computer-generated microforms following the data on a roll of film or in the last frames of a single microfiche, or the last frames of the last fiche in a series. Other index locations may be used only if dictated by special system constraints.

### § 1230.14 What are the filming requirements for permanent and unscheduled records?

(a) *General requirements.* (1) Apply the standards in this section for microfilming of:

(i) Permanent paper records where the original paper record will be destroyed or otherwise disposed of;

(ii) Unscheduled paper records where the original paper record will be destroyed or otherwise disposed of; and

(iii) Permanent and unscheduled original microform records (no paper originals) produced by automation, such as computer output microfilm (COM).

(2) Do not destroy permanent or unscheduled paper records after microfilming without authorization from NARA on a SF 115 (see § 1230.10(a)).

(b) *Film stock standards.* Polyester-based silver gelatin type film that conforms to ANSI/NAPM IT9.1-1996 for LE 500 film must be used in all applications.

(c) *Processing standards.* Microforms must be processed so that the residual thiosulfate ion concentration will not exceed 0.014 grams per square meter in accordance with ANSI/NAPM IT9.1-1996. Follow processing procedures in ANSI/AIIM MS1-1996 and MS23-1998.

(d) *Quality standards.* (1) *Resolution.* (i) *Source documents.* Determine minimum resolution on microforms of source documents using the method in



the Quality Index Method for determining resolution and anticipated losses when duplicating, as described in ANSI/AIIM MS23-1998 and MS43-1998. Perform resolution tests using a ISO 3334-1991 Resolution Test Chart or a commercially available certifiable target manufactured to comply with this standard, and read the patterns following the instructions of ISO 3334-1991. Use the smallest character used to display information to determine the height used in the Quality Index formula. A Quality Index of five is required at the third generation level.

(ii) *COM*. Computer output microforms (COM) must meet the requirements of ANSI/AIIM MS1-1996.

(2) *Background density of images*. The background ISO standard visual diffuse transmission density on microforms must be appropriate to the type of documents being filmed. The procedure for density measurement is described in ANSI/AIIM MS23-1998. The densitometer must meet with ANSI/NAPM IT2.18-1996, for spectral conditions and ANSI/NAPM IT2.19-1994, for geometric conditions for transmission density.

(i) Recommended visual diffuse transmission background densities for images of documents are as follows:

Classification	Description of document	Background density
Group 1	High-quality, high contrast printed book, periodicals, and black typing.	1.3-1.5
Group 2	Fine-line originals, black opaque pencil writing, and documents with small high contrast printing.	1.15-1.4
Group 3	Pencil and ink drawings, faded printing, and very small printing, such as footnotes at the bottom of a printed page.	1.0-1.2
Group 4	Low-contrast manuscripts and drawing, graph paper with pale, fine-colored lines; letters typed with a worn ribbon; and poorly printed, faint documents.	0.8-1.0
Group 5	Poor-contrast documents (special exception).	0.7-0.85

(ii) Recommended visual diffuse transmission densities for computer generated images are as follows:

Film Type	Process	Density Measurement Method	Min. Dmax <sup>1</sup>	Max. Dmin <sup>1</sup>	Minimum Density Difference
Silver gelatin	Conventional	Printing or diffuse	0.75	0.15	0.60
Silver gelatin	Full reversal	Printing	1.50	0.20	1.30

<sup>1</sup>Character or line density, measured with a microdensitometer or by comparing the film under a microscope with an image of a known density.

(3) *Base plus fog density of films.* The base plus fog density of unexposed, processed films must not exceed 0.10. When a tinted base film is used, the density will be increased. The difference must be added to the values given in the tables in paragraph (d)(2) of this section.

(4) *Line or stroke width.* Due to optical limitations in most photographic systems, film images of thin lines appearing in the original document will tend to fill in as a function of their width and density. Therefore, as the reduction ratio of a given system is increased, reduce the background density as needed to ensure that the copies will be legible.

**§ 1230.16 What are the film and image requirements for temporary records, duplicates, and user copies?**

(a) *Temporary records with a retention period over 99 years.* Follow the film and image requirements in § 1230.14.

(b) *Temporary records to be kept for less than 100 years.* NARA does not require the use of specific standards. Select a film stock that meets agency needs and ensures the preservation of the microforms for their full retention period. Consult appropriate ANSI standards, available as noted in § 1230.3, or manufacturer's instructions for processing microfilm of these temporary

records. Follow the manufacturer's recommendations for production and maintenance of temporary microfilm to ensure that the image is accessible and usable for the entire retention period.

**Subpart D—Storage, Use and Disposition Standards for Microform Records**

**§ 1230.20 How should microform records be stored?**

(a) *Permanent and unscheduled records.* Store permanent and unscheduled microform records under the extended term storage conditions specified in ISO 18911:2000 and ANSI/PIMA IT9.2-1998, except that the relative humidity of the storage area must be a constant 35 percent RH, plus or minus 5 percent. Do not store non-silver copies of microforms in the same storage area as silver gelatin originals or duplicate copies.

(b) *Temporary records.* Store temporary microform records under conditions that will ensure their preservation for their full retention period. Agencies may consult Life Expectance (LE) guidelines in ANSI/AIIM standards (see § 1230.3 for availability) for measures that can be used to meet retention requirements.

**§ 1230.22 What are NARA inspection requirements for permanent and unscheduled microform records?**

(a) Agencies must inspect, or arrange to pay a contractor or NARA to inspect the following categories of microform records stored at the agency, at a commercial records storage facility, or at a NARA records center following the inspection requirements in paragraph (b) of this section:

- (1) Master films of permanent records microfilmed in order to dispose of the original records;
- (2) Master films of permanent records originally created on microfilm;
- (3) Other master films scheduled for transfer to the National Archives; and
- (4) Master films of unscheduled records.

(b) The films listed in paragraph (a) of this section must be inspected initially in accordance with ANSI/AIIM MS45—1990. All films must be inspected when they are 2 years old. After the initial 2-year inspection, unless there is a catastrophic event, the films must be inspected as follows until legal custody is transferred to the National Archives and Records Administration:

(1) For microfilm that is/was produced after 1990, inspect the microfilm every 5 years.

(2) For microfilm that was produced prior to 1990, inspect the microfilm every 2 years.

(c) To facilitate inspection, the agency must maintain an inventory of microfilm listing each microform series/publication by production date, producer, processor, format, and results of previous inspections.

(d) The elements of the inspection shall consist of:

- (1) An inspection for aging blemishes following ANSI/AIIM MS45—1990;
- (2) A rereading of resolution targets;
- (3) A remeasurement of density; and
- (4) A certification of the environmental conditions under which the microforms are stored, as specified in § 1230.20(a).

(e) The agency must prepare an inspection report, and send a copy to NARA in accordance with § 1230.28(b). The inspection report must contain:

(1) A summary of the inspection findings, including:

(i) A list of batches by year that includes the identification numbers of microfilm rolls and microfiche in each batch;

(ii) The quantity of microforms inspected;

(iii) An assessment of the overall condition of the microforms;

(iv) A summary of any defects discovered, e.g., redox blemishes or base deformation; and

(v) A summary of corrective action taken.

(2) A detailed inspection log created during the inspection that contains the following information:

(i) A complete description of all records inspected (title; roll or fiche number or other unique identifier for each unit of film inspected; security classification, if any; and inclusive dates, names, or other data identifying the records on the unit of film);

(ii) The date of inspection;

(iii) The elements of inspection (see paragraph (a)(4) of this section);

(iv) Any defects uncovered; and

(v) The corrective action taken.

(f) If an inspection shows that a master microform is deteriorating, the agency must make a silver duplicate in accordance with § 1230.14 to replace the deteriorating master. The duplicate film will be subject to the inspection requirements (see § 1230.22) before transfer to a record center or to the National Archives.

(g) Inspection must be performed in an environmentally controlled area in accordance with ANSI/AIIM MS45—1990.

**§ 1230.24 What are NARA inspection requirements for temporary microform records?**

NARA recommends, but does not require, that agencies use the inspection by sampling procedures described in § 1230.22(a) and (b).

**§ 1230.26 What are the use restrictions for permanent and unscheduled microform records?**

(a) Do not use the silver gelatin original microform or duplicate silver gelatin microform of permanent or unscheduled records created in accordance with § 1230.14 of this part (archival microform) for reference purposes. Agencies must ensure that the archival microform remains clean and

## § 1230.28

undamaged during the process of making a duplicating master.

(b) Use duplicates for:

- (1) Reference;
- (2) Further duplication on a recurring basis;
- (3) Large-scale duplication; and
- (4) Distribution of records on microform.

(c) Agencies retaining the original record in accordance with an approved records disposition schedule may apply agency standards for the use of microform records.

### § 1230.28 What must agencies do to send permanent microform records to a records storage facility?

(a) Follow the procedures in part 1228, subpart I, of this chapter and the additional requirements in this section.

(b) Package non-silver copies separately from the silver gelatin original or silver duplicate microform copy and clearly label them as non-silver copies.

(c) Include the following information on the transmittal (SF 135 for NARA records centers), or in an attachment to the transmittal. For records sent to an agency records center or commercial records storage facility, submit this information to NARA as part of the documentation required by § 1228.154(c)(2) of this chapter:

- (1) Name of the agency and program component;
- (2) The title of the records and the media/format used;
- (3) The number or identifier for each unit of film;
- (4) The security classification, if any;
- (5) The inclusive dates, names, or other data identifying the records to be included on a unit of film;
- (6) Finding aids that are not contained in the microform; and
- (7) The inspection log forms and inspection reports required by § 1230.22(a)(5) and (6).

(d) Agencies may transfer permanent microform records to a records storage facility meeting the storage requirements in § 1230.20(a) (see § 1228.152(e)(3) of this chapter for NARA centers) only after the first inspection or with certification that the microforms will be inspected by the agency, an agency contractor, or a NARA records center

## 36 CFR Ch. XII (7-1-03 Edition)

(on a reimbursable basis) when the microforms become 2 years old.

### § 1230.30 How do agencies transfer permanent microform records to the legal custody of the National Archives?

(a) Follow the procedures in part 1228, subpart L, of this chapter and the additional requirements in this section.

(b) Originate the transfer by submitting an SF 258, Agreement to Transfer Records to the National Archives of the United States, unless otherwise instructed by NARA.

(c) If the records are not in a NARA records center, submit the information specified in § 1230.28(c).

(d) Transfer the silver gelatin original (or duplicate silver gelatin microform created in accordance with § 1230.14) plus one microform copy.

(e) Ensure that the inspection of the microform is up-to-date. If the microform records were recently produced, please note that NARA will not accession permanent microform records until the first inspection (when the microforms are 2 years old) has been performed.

(f) Package non-silver copies separately from the silver gelatin original or silver duplicate microform copy and clearly label them as non-silver copies.

## Subpart E—Centralized Micrographic Services

### § 1230.50 What micrographic services are available from NARA?

Some NARA records centers provide reimbursable microfilming services, including preparing, indexing, and filming of records, inspection of film, and labeling of film containers. Agencies desiring microfilming services from NARA should contact the Office of Regional Records Services (NR), 8601 Adelphi Rd., College Park, MD 20740-6001, or the director of the NARA records center serving the agency's records (see § 1228.150(a) of this chapter). The fees for microfilming services will appear in NARA bulletins, which are available on NARA's web site at <http://www.nara.gov/records/policy/bulletin.html> or from the Modern Records

Programs (NWM), 8601 Adelphi Road, College Park, MD 20740-6001.

## PART 1232—AUDIOVISUAL RECORDS MANAGEMENT

### Subpart A—General

Sec.

- 1232.1 Applicability and scope.
- 1232.2 Objectives.
- 1232.10 Definitions.

### Subpart B—Audiovisual Records Management

- 1232.20 Agency program responsibilities.
- 1232.22 Nitrocellulose film.
- 1232.24 Unstable cellulose-acetate film.
- 1232.26 Storage conditions.
- 1232.28 Maintenance and operations.
- 1232.30 Choosing formats.
- 1232.32 Disposition.

AUTHORITY: 44 U.S.C. 2904 and 3101; and OMB Circular A-130.

SOURCE: 61 FR 32337, June 24, 1996, unless otherwise noted.

### Subpart A—General

#### § 1232.1 Applicability and scope.

This part prescribes policies and procedures for managing audiovisual records to ensure adequate and proper documentation and authorized, timely, and appropriate disposition.

#### § 1232.2 Objectives.

The objectives of audiovisual records management are to achieve the effective creation, maintenance, use, and disposition of audiovisual and related records by establishing standards for maintenance and disposition, physical security, and preservation and by reviewing recordkeeping practices on a continuing basis to improve procedures.

#### § 1232.10 Definitions.

For the purposes of this part, the following definitions shall apply (see also § 1220.14 of this chapter for other definitions).

*Audiovisual.* Any pictorial or aural means of communicating information.

*Audiovisual equipment.* Equipment used for recording, producing, duplicating, processing, broadcasting, distributing, storing or exhibiting audio-

visual materials or for providing any audiovisual services.

*Audiovisual production.* An organized and unified presentation, developed according to a plan or script, containing visual imagery, sound, or both, and used to convey information. An audiovisual production generally is a self-contained presentation. Audiovisual productions may include motion media with synchronous sound such as motion picture film, videotape or other video formats, audio recordings, and other media such as synchronized audio and visual presentations such as multimedia productions.

*Audiovisual records.* Records in pictorial or aural form that include still and motion media, sound recordings, graphic works, mixed media, and related finding aids and production files.

### Subpart B—Audiovisual Records Management

#### § 1232.20 Agency program responsibilities.

Each Federal agency, in providing for effective controls over the creation of records, shall establish an appropriate program for the management of audiovisual records. This program shall be governed by the following requirements:

(a) Prescribe the types of records to be created and maintained so that audiovisual activities and their products are properly documented. (Regulations on the appropriate types of permanent audiovisual records are located in § 1228.266 of this chapter.)

(b) Ensure that adequate training is provided to:

(1) Agency personnel responsible for the disposition of audiovisual records;

(2) Contractor personnel who have temporary custody of audiovisual records; and,

(3) All users who create, handle, or maintain audiovisual records or operate equipment for their use.

(c) Ensure that contract provisions protect the Government's legal title and control over audiovisual records and related documentation produced or maintained by contract. Ensure that contract provisions identify as deliverables any working papers/files

## § 1232.22

that are needed for adequate and proper documentation. Include a provision that permits the Government to inspect contractor facilities used for the storage and handling of permanent or unscheduled audiovisual records. Agencies shall inspect such facilities at least once each year.

(d) Keep inventories indicating the location of all generations of audiovisual records, whether in agency storage or in another facility such as a laboratory or library distribution center.

(e) Schedule disposition of all audiovisual records as soon as practicable after creation. General Records Schedule 21 provides mandatory disposal authorization for temporary audiovisual records common to most Federal offices. Agencies must submit an SF 115, Request for Records Disposition Authority, to NARA to obtain authorization for the disposition of all other audiovisual records. The schedules covering permanent records must specify the different record elements identified in §1228.266, and must always include related finding aids.

(f) Periodically review agency audiovisual recordkeeping practices for conformance with requirements and take necessary corrective action.

[61 FR 32337, June 24, 1996, as amended at 66 FR 27027, May 16, 2001]

### § 1232.22 Nitrocellulose film.

Nitrocellulose-base film once used in the manufacture of sheet film and motion pictures may be occasionally found in records storage areas. The nitrocellulose base, a substance akin to gun cotton, is chemically unstable and highly inflammable.

(a) Agencies must remove nitrocellulose film materials from records storage areas.

(b) Agencies must immediately notify NARA about the existence of nitrocellulose film materials because of their age and instability. NARA will determine if they may be destroyed or destroyed after a copy is made for transfer, as appropriate.

(c) If NARA appraises nitrate film materials as disposable, but the agency wishes to retain them, agencies must follow the guidance in NFPA 40-1994, Standard for the Storage and Handling of Cellulose Nitrate Motion Picture

## 36 CFR Ch. XII (7-1-03 Edition)

Film, which is incorporated by reference. NFPA 40-1994 is available from the National Fire Protection Association, Batterymarch Park, Quincy, MA 02269. This standard is also available for inspection at the Office of the Federal Register, 800 North Capitol Street, NW., suite 700, Washington, D.C. This incorporation by reference was approved by the Director of the Federal Register in accordance with 5 U.S.C. 552(a) and 1 CFR part 51. These materials are incorporated by reference as they exist on the date of approval and a notice of any change in these materials will be published in the FEDERAL REGISTER.

(d) The packing and shipping of nitrate film are governed by the following Department of Transportation regulations: 49 CFR 172.101, Hazardous materials table; 172.504, Transportation; 173.24, Standard requirements for all packages; and 173.177, Motion picture film and X-ray film—nitrocellulose base.

### § 1232.24 Unstable cellulose-acetate film.

Cellulose-acetate film, also known as safety film, is nonflammable and does not represent the same degree of hazard as nitrate film materials. Nonetheless, cellulose-acetate film also deteriorates over time. Temperature, humidity, harmful storage enclosures, and gaseous products influence the rate of deterioration. Agencies shall inspect cellulose-acetate film periodically for an acetic odor, wrinkling, or the presence of crystalline deposits on the edge or surface of the film that indicate deterioration. Agencies shall notify NARA within 30 days after inspection about deteriorating permanent or unscheduled audiovisual records composed of cellulose acetate so that they can be copied.

### § 1232.26 Storage conditions.

Agencies must:

(a) Provide audiovisual records storage facilities that are secure from unauthorized access and make them safe from fire, water, flood, chemical or gas damage and from other harmful conditions. See NFPA 232A-1995, Guide for Fire Protection for Archives and Records Centers issued by the National

Fire Protection Association, which is incorporated by reference. The standard is available from the National Fire Protection Association, Batterymarch Park, Quincy, MA 02269. This standard is also available for inspection at the Office of the Federal Register, 800 North Capitol Street, NW., suite 700, Washington, D.C. This incorporation by reference was approved by the Director of the Federal Register in accordance with 5 U.S.C. 552(a) and 1 CFR part 51. These materials are incorporated by reference as they exist on the date of approval and a notice of any change in these materials will be published in the FEDERAL REGISTER.

(b) Maintain good ambient storage conditions for permanent or unscheduled audiovisual records. Generally, the temperature should not exceed 70 degrees Fahrenheit and relative humidity should be maintained between 30-40% and not exceed 50%. Avoid fluctuating temperatures and humidity. Cooler temperatures and lower relative humidity are recommended for the storage of all film, to prolong the useful life of the film base and image. Cold temperatures combined with 30-35% relative humidity are especially recommended to retard the fading of color film. Optimal environmental conditions are stated in ANSI/NAPM IT9.11-1993, Imaging Media—Processed Safety Photographic Films—Storage. If possible store all permanently scheduled records in these conditions, and schedule them to be transferred to the National Archives as soon as possible.

(c) For the storage of permanent or unscheduled records, use audiovisual storage containers or enclosures made of noncorroding metal, inert plastics, paper products and other safe materials recommended and specified in ANSI standards: ANSI/NAPM IT9.11-1993, Imaging Media—Processed Safety Photographic Films—Storage; and ANSI IT9.2-1991, Imaging Media—Photographic Processed Films, Plates, and Papers—Filing Enclosures and Storage Containers. These standards, which are incorporated by reference, are available from the American National Standards Institute (ANSI), Inc., 11 West 42nd Street, New York, NY 10036. These standards are also available for inspection at the Office of the Federal

Register, 800 North Capitol Street, NW., suite 700, Washington, D.C. This incorporation by reference was approved by the Director of the Federal Register in accordance with 5 U.S.C. 552(a) and 1 CFR part 51. These materials are incorporated by reference as they exist on the date of approval and a notice of any change in these materials will be published in the FEDERAL REGISTER.

(d) Store originals and use copies (e.g., negatives and prints) separately, whenever practicable.

(e) Store series of permanent and unscheduled x-ray films in accordance with this section, and store series of temporary x-ray films under conditions that will ensure their preservation for their full retention period, in accordance with ANSI/NAPM IT9.11-1993, Imaging Media—Processed Safety Photographic Films—Storage. This requirement does not apply to x-rays that are interspersed among paper records, as in case files.

#### § 1232.28 Maintenance and operations.

Agencies must:

(a) Handle audiovisual records in accordance with commonly accepted industry practices because of their extreme vulnerability to damage. For further information, consult the American National Standards Institute (ANSI), Inc., 11 West 42nd Street, New York, NY 10036; and the Society of Motion Picture and Television Engineers, 595 West Hartsdale Avenue, White Plains, NY 10607.

(b) Use only personnel trained to perform their audiovisual duties and responsibilities and ensure that equipment intended for projection or playback is in good working order.

(c) Loan permanent or unscheduled audiovisual records to non-Federal recipients only in conformance with the provisions of part 1228 subpart E of this chapter. Such records may be loaned to other Federal agencies only if a record copy is maintained in the agency's custody.

(d) Take all steps necessary to prevent accidental or deliberate alteration or erasure of audiovisual records.

(e) Ensure that no information recorded on permanent or unscheduled

### § 1232.30

magnetic sound or video media is erased.

(f) If different versions of audiovisual productions (e.g., short and long versions or foreign-language versions) are prepared, keep an unaltered copy of each version for record purposes.

(g) Maintain the association between audiovisual records and the finding aids for them, such as captions and published and unpublished catalogs, and production files and similar documentation created in the course of audiovisual production.

(h) Maintain disposable audiovisual records separate from permanent ones in accordance with General Records Schedule 21 and a records schedule approved by NARA for the agency's other audiovisual records.

### § 1232.30 Choosing formats.

Agencies must:

(a) When ordering photographic materials for permanent or unscheduled records, ensure that still picture negatives and motion picture preprints (negatives, masters, etc.) are composed of polyester bases and are processed in accordance with industry standards as specified in ANSI/ISO 543-1990 (ANSI IT9.6-1991) Photography—Photographic Films—Specifications for Safety Film; and, ANSI/NAPM IT9.1-1992 Imaging Media (Film)—Silver-Gelatin Type—Specifications for Stability, which are incorporated by reference. (Currently, not all motion picture stocks are available on a polyester base.) It is particularly important to ensure that residual sodium thiosulfate (hypo) on newly processed black-and-white photographic film does not exceed .014 grams per square meter. Require laboratories to process film in accordance with this standard. Excessive hypo will shorten the longevity of film and accelerate color fading. Process color film in accordance with the manufacturer's recommendations. If using reversal type processing, request full photographic reversal; i.e., develop, bleach, expose, develop, fix, and wash. The standards cited in this paragraph are available from the American National Standards Institute (ANSI), Inc., 11 West 42nd Street, New York, NY 10036. These standards are also available for inspection at the Office of the Federal Reg-

### 36 CFR Ch. XII (7-1-03 Edition)

ister, 800 North Capitol Street, NW., suite 700, Washington, D.C. This incorporation by reference was approved by the Director of the Federal Register in accordance with 5 U.S.C. 552(a) and 1 CFR part 51. These materials are incorporated by reference as they exist on the date of approval and a notice of any change in these materials be published in the FEDERAL REGISTER.

(b) Refrain from using motion pictures in a final "A & B" format (two precisely matched reels designed to be printed together) for the reproduction of excerpts or stock footage.

(c) Use only industrial or professional recording equipment and videotape, previously unrecorded, for original copies of permanent or unscheduled recordings. Limit the use of consumer formats to distribution or reference copies or to subjects scheduled for disposal. Video cassettes in the VHS format are unsuitable for use as originals of permanent or unscheduled records due to their inability to be copied without significant loss in image quality.

(d) Record permanent or unscheduled audio recordings on 1/4-inch open-reel tapes at 3 3/4 or 7 1/2 inches per second, full track, using professional unrecorded polyester splice-free tape stock. Audio cassettes, including mini-cassettes, are not sufficiently durable for use as originals in permanent records or unscheduled records although they may be used as reference copies.

### § 1232.32 Disposition.

The disposition of audiovisual records shall be carried out in the same manner as that prescribed for other types of records in part 1228 of this chapter. For further instructions on the transfer of permanent audiovisual records to the National Archives see § 1228.266 of this chapter, Audiovisual Records.

[61 FR 32337, June 24, 1996, as amended at 66 FR 27027, May 16, 2001]

## PART 1234—ELECTRONIC RECORDS MANAGEMENT

### Subpart A—General

Sec.

1234.1 Scope of part.

1234.2 Definitions.



**Subpart B—Program Requirements**

1234.10 Agency responsibilities.

**Subpart C—Standards for the Creation, Use, Preservation, and Disposition of Electronic Records**

1234.20 Creation and use of data files.

1234.22 Creation and use of text documents.

1234.24 Standards for managing electronic mail records.

1234.26 Judicial use of electronic records.

1234.28 Security of electronic records.

1234.30 Selection and maintenance of electronic records storage media.

1234.32 Retention and disposition of electronic records.

1234.34 Destruction of electronic records.

AUTHORITY: 44 U.S.C. 2904, 3101, 3102, and 3105.

SOURCE: 55 FR 19218, May 8, 1990, unless otherwise noted.

**Subpart A—General****§ 1234.1 Scope of part.**

This part establishes the basic requirements related to the creation, maintenance, use, and disposition of electronic records. Electronic records include numeric, graphic, and text information, which may be recorded on any medium capable of being read by a computer and which satisfies the definition of a record. This includes, but is not limited to, magnetic media, such as tapes and disks, and optical disks. Unless otherwise noted, these requirements apply to all electronic information systems, whether on microcomputers, minicomputers, or mainframe computers, regardless of storage media, in network or stand-alone configurations. This part also covers creation, maintenance and use, and disposition of Federal records created by individuals using electronic mail applications.

[60 FR 44640, Aug. 28, 1995]

**§ 1234.2 Definitions.**

Basic records management terms are defined in 36 CFR 1220.14. As used in part 1234—

*Data base* means a set of data, consisting of at least one data file, that is sufficient for a given purpose.

*Data base management system* means a software system used to access and retrieve data stored in a data base.

*Data file* means related numeric, textual, or graphic information that is organized in a strictly prescribed form and format.

*Electronic information system.* A system that contains and provides access to computerized Federal records and other information.

*Electronic mail message.* A document created or received on an electronic mail system including brief notes, more formal or substantive narrative documents, and any attachments, such as word processing and other electronic documents, which may be transmitted with the message.

*Electronic mail system.* A computer application used to create, receive, and transmit messages and other documents. Excluded from this definition are file transfer utilities (software that transmits files between users but does not retain any transmission data), data systems used to collect and process data that have been organized into data files or data bases on either personal computers or mainframe computers, and word processing documents not transmitted on an e-mail system.

*Electronic record* means any information that is recorded in a form that only a computer can process and that satisfies the definition of a Federal record in 44 U.S.C. 3301.

*Electronic recordkeeping system.* An electronic system in which records are collected, organized, and categorized to facilitate their preservation, retrieval, use, and disposition.

*Text documents* means narrative or tabular documents, such as letters, memorandums, and reports, in loosely prescribed form and format.

*Transmission and receipt data.*

(1) *Transmission data.* Information in electronic mail systems regarding the identities of sender and addressee(s), and the date and time messages were sent.

(2) *Receipt data.* Information in electronic mail systems regarding date and time of receipt of a message, and/or acknowledgment of receipt or access by addressee(s).

[55 FR 19218, May 8, 1990, as amended at 60 FR 44641, Aug. 28, 1995]

**Subpart B—Program Requirements****§ 1234.10 Agency responsibilities.**

The head of each Federal agency shall ensure that the management of electronic records incorporates the following elements:

(a) Assigning responsibility to develop and implement an agencywide program for the management of all records created, received, maintained, used, or stored on electronic media; and notifying the National Archives and Records Administration, Modern Records Programs (NWM), 8601 Adelphi Rd., College Park, MD 20740-6001 and the General Services Administration, Office of Government Policy (MKB), Washington, DC 20405, of the name and title of the person assigned the responsibility.

(b) Integrating the management of electronic records with other records and information resources management programs of the agency.

(c) Incorporating electronic records management objectives, responsibilities, and authorities in pertinent agency directives and disseminating them throughout the agency as appropriate.

(d) Establishing procedures for addressing records management requirements, including recordkeeping requirements and disposition, before approving new electronic information system or enhancements to existing systems.

(e) Ensuring that adequate training is provided for users of electronic mail systems on recordkeeping requirements, the distinction between Federal records and nonrecord materials, procedures for designating Federal records, and moving or copying records for inclusion in an agency recordkeeping system;

(f) Ensuring that adequate training is provided for users of electronic information system in the operation, care, and handling of the equipment, software, and media used in the system.

(g) Developing and maintaining up-to-date documentation about all electronic information system that is adequate to: Specify all technical characteristics necessary for reading or processing the records; identify all defined inputs and outputs of the system; de-

fine the contents of the files and records; determine restrictions on access and use; understand the purpose(s) and function(s) of the system; describe update cycles or conditions and rules for adding information to the system, changing information in it, or deleting information; and ensure the timely, authorized disposition of the records.

(h) Specifying the location, manner, and media in which electronic records will be maintained to meet operational and archival requirements, and maintaining inventories of electronic information system to facilitate disposition.

(i) Developing and securing NARA approval of records disposition schedules, and ensuring implementation of their provisions.

(j) Specifying the methods of implementing controls over national security-classified, sensitive, proprietary, and Privacy Act records stored and used electronically.

(k) Establishing procedures to ensure that the requirements of this part are applied to those electronic records that are created or maintained by contractors.

(l) Ensuring compliance with applicable Governmentwide policies, procedures, and standards such as those issued by the Office of Management and Budget, the General Accounting Office, the General Services Administration, the National Archives and Records Administration, and the National Institute of Standards and Technology.

(m) Reviewing electronic information system periodically for conformance to established agency procedures, standards, and policies as part of the periodic reviews required by 44 U.S.C. 3506. The review should determine if the records have been properly identified and described, and whether the schedule descriptions and retention periods reflect the current informational content and use. If not, or if substantive changes have been made in the structure, design, codes, purposes, or uses of the system, submit an SF 115, Request for Records Disposition Authority, to NARA.

[55 FR 19218, May 8, 1990, as amended at 60 FR 44641, Aug. 28, 1995; 63 FR 35830, July 1, 1998; 66 FR 27028, May 16, 2001]

### Subpart C—Standards for the Creation, Use, Preservation, and Disposition of Electronic Records

#### § 1234.20 Creation and use of data files.

(a) For electronic information systems that produce, use, or store data files, disposition instructions for the data shall be incorporated into the system's design.

(b) Agencies shall maintain adequate and up-to-date technical documentation for each electronic information system that produces, uses, or stores data files. Minimum documentation required is a narrative description of the system; physical and technical characteristics of the records, including a record layout that describes each field including its name, size, starting or relative position, and a description of the form of the data (such as alphabetic, zoned decimal, packed decimal, or numeric), or a data dictionary or the equivalent information associated with a data base management system including a description of the relationship between data elements in data bases; and any other technical information needed to read or process the records.

[55 FR 19218, May 8, 1990, as amended at 60 FR 44641, Aug. 28, 1995]

#### § 1234.22 Creation and use of text documents.

(a) Electronic recordkeeping systems that maintain the official file copy of text documents on electronic media shall meet the following minimum requirements:

(1) Provide a method for all authorized users of the system to retrieve desired documents, such as an indexing or text search system;

(2) Provide an appropriate level of security to ensure integrity of the documents;

(3) Provide a standard interchange format when necessary to permit the exchange of documents on electronic media between agency computers using different software/operating systems and the conversion or migration of documents on electronic media from one system to another; and

(4) Provide for the disposition of the documents including, when necessary, the requirements for transferring permanent records to NARA (see § 1228.270 of this chapter).

(b) Before a document is created electronically on electronic recordkeeping systems that will maintain the official file copy on electronic media, each document shall be identified sufficiently to enable authorized personnel to retrieve, protect, and carry out the disposition of documents in the system. Appropriate identifying information for each document maintained on the electronic media may include: office of origin, file code, key words for retrieval, addressee (if any), signator, author, date, authorized disposition (coded or otherwise), and security classification (if applicable). Agencies shall ensure that records maintained in such systems can be correlated with related records on paper, microform, or other media.

[55 FR 19218, May 8, 1990, as amended at 60 FR 44641, Aug. 28, 1995; 66 FR 27028, May 16, 2001]

#### § 1234.24 Standards for managing electronic mail records.

Agencies shall manage records created or received on electronic mail systems in accordance with the provisions of this chapter pertaining to adequacy of documentation, recordkeeping requirements, agency records management responsibilities, and records disposition (36 CFR parts 1220, 1222, and 1228).

(a) Agency instructions on identifying and preserving electronic mail messages will address the following unique aspects of electronic mail:

(1) Some transmission data (names of sender and addressee(s) and date the message was sent) must be preserved for each electronic mail record in order for the context of the message to be understood. Agencies shall determine if any other transmission data is needed for purposes of context.

(2) Agencies that use an electronic mail system that identifies users by codes or nicknames or identifies addressees only by the name of a distribution list shall instruct staff on how to retain names on directories or

**§ 1234.26**

**36 CFR Ch. XII (7-1-03 Edition)**

distributions lists to ensure identification of the sender and addressee(s) of messages that are records.

(3) Agencies that use an electronic mail system that allows users to request acknowledgments or receipts showing that a message reached the mailbox or inbox of each addressee, or that an addressee opened the message, shall issue instructions to e-mail users specifying when to request such receipts or acknowledgments for recordkeeping purposes and how to preserve them.

(4) Agencies with access to external electronic mail systems shall ensure that Federal records sent or received on these systems are preserved in the appropriate recordkeeping system and that reasonable steps are taken to capture available transmission and receipt data needed by the agency for recordkeeping purposes.

(5) Some e-mail systems provide calendars and task lists for users. These may meet the definition of Federal record. Calendars that meet the definition of Federal records are to be managed in accordance with the provisions of General Records Schedule 23, Item 5.

(6) Draft documents that are circulated on electronic mail systems may be records if they meet the criteria specified in 36 CFR 1222.34.

(b) Agencies shall consider the following criteria when developing procedures for the maintenance of electronic mail records in appropriate recordkeeping systems, regardless of format.

(1) Recordkeeping systems that include electronic mail messages must:

(i) Provide for the grouping of related records into classifications according to the nature of the business purposes the records serve;

(ii) Permit easy and timely retrieval of both individual records and files or other groupings of related records;

(iii) Retain the records in a usable format for their required retention period as specified by a NARA-approved records schedule;

(iv) Be accessible by individuals who have a business need for information in the system;

(v) Preserve the transmission and receipt data specified in agency instructions; and

(vi) Permit transfer of permanent records to the National Archives and Records Administration (see 36 CFR 1228.270 and 36 CFR 1234.32(a)).

(2) Agencies shall not store the recordkeeping copy of electronic mail messages that are Federal records only on the electronic mail system, unless the system has all of the features specified in paragraph (b)(1) of this section. If the electronic mail system is not designed to be a recordkeeping system, agencies shall instruct staff on how to copy Federal records from the electronic mail system to a recordkeeping system.

(c) Agencies that maintain their electronic mail records electronically shall move or copy them to a separate electronic recordkeeping system unless their system has the features specified in paragraph (b)(1) of this section. Because they do not have the features specified in paragraph (b)(1) of this section, backup tapes should not be used for recordkeeping purposes. Agencies may retain records from electronic mail systems in an off-line electronic storage format (such as optical disk or magnetic tape) that meets the requirements described at 36 CFR 1234.30(a). Agencies that retain permanent electronic mail records scheduled for transfer to the National Archives shall either store them in a format and on a medium that conforms to the requirements concerning transfer at 36 CFR 1228.188 or shall maintain the ability to convert the records to the required format and medium at the time transfer is scheduled.

(d) Agencies that maintain paper files as their recordkeeping systems shall print their electronic mail records and the related transmission and receipt data specified by the agency.

[60 FR 44641, Aug. 28, 1995, as amended at 66 FR 27028, May 16, 2001]

**§ 1234.26 Judicial use of electronic records.**

Electronic records may be admitted in evidence to Federal courts for use in court proceedings (Federal Rules of Evidence 803(8)) if trustworthiness is established by thoroughly documenting the recordkeeping system's operation and the controls imposed upon it.

Agencies should implement the following procedures to enhance the legal admissibility of electronic records.

(a) Document that similar kinds of records generated and stored electronically are created by the same processes each time and have a standardized retrieval approach.

(b) Substantiate that security procedures prevent unauthorized addition, modification or deletion of a record and ensure system protection against such problems as power interruptions.

(c) Identify the electronic media on which records are stored throughout their life cycle, the maximum time span that records remain on each storage medium, and the NARA-approved disposition of all records.

(d) Coordinate all of the above with legal counsel and senior IRM and records management staff.

[55 FR 19218, May 8, 1990. Redesignated at 60 FR 44641, Aug. 28, 1995]

**§ 1234.28 Security of electronic records.**

Agencies shall implement and maintain an effective records security program that incorporates the following:

(a) Ensures that only authorized personnel have access to electronic records.

(b) Provides for backup and recovery of records to protect against information loss.

(c) Ensures that appropriate agency personnel are trained to safeguard sensitive or classified electronic records.

(d) Minimizes the risk of unauthorized alteration or erasure of electronic records.

(e) Ensures that electronic records security is included in computer systems security plans prepared pursuant to the Computer Security Act of 1987 (40 U.S.C. 759 *note*).

[55 FR 19218, May 8, 1990. Redesignated at 60 FR 44641, Aug. 28, 1995]

**§ 1234.30 Selection and maintenance of electronic records storage media.**

(a) Agencies shall select appropriate media and systems for storing agency records throughout their life, which meet the following requirements:

(1) Permit easy retrieval in a timely fashion;

(2) Facilitate distinction between record and nonrecord material;

(3) Retain the records in a usable format until their authorized disposition date; and

(4) If the media contains permanent records and does not meet the requirements for transferring permanent records to NARA as outlined in § 1228.270 of this chapter, permit the migration of the permanent records at the time of transfer to a medium which does meet the requirements.

(b) The following factors shall be considered before selecting a storage medium or converting from one medium to another:

(1) The authorized life of the records, as determined during the scheduling process;

(2) The maintenance necessary to retain the records;

(3) The cost of storing and retrieving the records;

(4) The records density;

(5) The access time to retrieve stored records;

(6) The portability of the medium (that is, selecting a medium that will run on equipment offered by multiple manufacturers) and the ability to transfer the information from one medium to another (such as from optical disk to magnetic tape); and

(7) Whether the medium meets current applicable Federal Information Processing Standards.

(c) Agencies should avoid the use of floppy disks for the exclusive long-term storage of permanent or unscheduled electronic records.

(d) Agencies shall ensure that all authorized users can identify and retrieve information stored on diskettes, removable disks, or tapes by establishing or adopting procedures for external labeling.

(e) Agencies shall ensure that information is not lost because of changing technology or deterioration by converting storage media to provide compatibility with the agency's current hardware and software. Before conversion to a different medium, agencies must determine that the authorized disposition of the electronic records can be implemented after conversion.

(f) Agencies shall back up electronic records on a regular basis to safeguard

§ 1234.32

36 CFR Ch. XII (7-1-03 Edition)

against the loss of information due to equipment malfunctions or human error. Duplicate copies of permanent or unscheduled records shall be maintained in storage areas separate from the location of the records that have been copied.

(g) *Maintenance of magnetic computer tape.* (1) Agencies shall test magnetic computer tapes no more than 6 months prior to using them to store electronic records that are unscheduled or scheduled for permanent retention. This test should verify that the tape is free of permanent errors and in compliance with National Institute of Standards and Technology or industry standards.

(2) Agencies shall maintain the storage and test areas for computer magnetic tapes containing permanent and unscheduled records at the following temperatures and relative humidities:

Constant temperature—62 to 68 °F.  
Constant relative humidity—35% to 45%

(3) Agencies shall annually read a statistical sample of all reels of magnetic computer tape containing permanent and unscheduled records to identify any loss of data and to discover and correct the causes of data loss. In tape libraries with 1800 or fewer reels, a 20% sample or a sample size of 50 reels, whichever is larger, should be read. In tape libraries with more than 1800 reels, a sample of 384 reels should be read. Tapes with 10 or more errors should be replaced and, when possible, lost data shall be restored. All other tapes which might have been affected by the same cause (i.e., poor quality tape, high usage, poor environment, improper handling) shall be read and corrected as appropriate.

(4) Agencies shall copy permanent or unscheduled data on magnetic tapes before the tapes are 10 years old onto tested and verified new tapes.

(5) External labels (or the equivalent automated tape management system) for magnetic tapes used to store permanent or unscheduled electronic records shall provide unique identification for each reel, including the name of the organizational unit responsible for the data, system title, and security classification, if applicable. Additionally, the following information shall be maintained for (but not necessarily at-

tached to) each reel used to store permanent or unscheduled electronic records: file title(s); dates of creation; dates of coverage; the recording density; type of internal labels; volume serial number, if applicable; number of tracks; character code/software dependency; information about block size; and reel sequence number, if the file is part of a multi-reel set. For numeric data files, include record format and logical record length, if applicable; data set name(s) and sequence, if applicable; and number of records for each data set.

(6) Agencies shall prohibit smoking and eating in magnetic computer tape storage libraries and test or evaluation areas that contain permanent or unscheduled records.

(h) *Maintenance of direct access storage media.* (1) Agencies shall issue written procedures for the care and handling of direct access storage media which draw upon the recommendations of the manufacturers.

(2) External labels for diskettes or removable disks used when processing or temporarily storing permanent or unscheduled records shall include the following information: name of the organizational unit responsible for the records, descriptive title of the contents, dates of creation, security classification, if applicable, and identification of the software and hardware used.

[55 FR 19218, May 8, 1990. Redesignated at 60 FR 44641, Aug. 28, 1995; 62 FR 54585, Oct. 21, 1997; 65 FR 24132, Apr. 25, 2000; 66 FR 27028, May 16, 2001]

**§ 1234.32 Retention and disposition of electronic records.**

Agencies shall establish policies and procedures to ensure that electronic records and their documentation are retained as long as needed by the Government. These retention procedures shall include provisions for:

(a) Scheduling the disposition of all electronic records, as well as related documentation and indexes, by applying General Records Schedules (particularly GRS 20 or GRS 23) as appropriate or submitting an SF 115, Request for Records Disposition Authority, to NARA (see part 1228 of this chapter). The information in electronic information systems, including those

operated for the Government by a contractor, shall be scheduled as soon as possible but no later than one year after implementation of the system.

(b) Transferring a copy of the electronic records and any related documentation and indexes to the National Archives at the time specified in the records disposition schedule in accordance with instructions found in § 1228.270 of this chapter. Transfer may take place at an earlier date if convenient for both the agency and the National Archives and Records Administration.

(c) Establishing procedures for regular recopying, reformatting, and other necessary maintenance to ensure the retention and usability of electronic records throughout their authorized life cycle (see § 1234.28).

(d) Electronic mail records may not be deleted or otherwise disposed of without prior disposition authority from NARA (44 U.S.C. 3303a). This applies to the original version of the record that is sent or received on the electronic mail system and any copies that have been transferred to a recordkeeping system. See 36 CFR part 1228 for records disposition requirements.

(1) *Disposition of records on the electronic mail system.* When an agency has taken the necessary steps to retain the record in a recordkeeping system, the identical version that remains on the user's screen or in the user's mailbox has no continuing value. Therefore, NARA has authorized deletion of the version of the record on the electronic mail system under General Records Schedule 20, Item 14, after the record has been preserved in a recordkeeping system along with all appropriate transmission data.

(2) *Records in recordkeeping systems.* The disposition of electronic mail records that have been transferred to an appropriate recordkeeping system is governed by the records schedule or schedules that control the records in that system. If the records in the system are not scheduled, the agency shall follow the procedures at 36 CFR part 1228.

[55 FR 19218, May 8, 1990. Redesignated and amended at 60 FR 44641, 44642, Aug. 28, 1995; 66 FR 27028, May 16, 2001]

#### § 1234.34 Destruction of electronic records.

Electronic records may be destroyed only in accordance with a records disposition schedule approved by the Archivist of the United States, including General Records Schedules. At a minimum each agency shall ensure that:

(a) Electronic records scheduled for destruction are disposed of in a manner that ensures protection of any sensitive, proprietary, or national security information.

(b) Magnetic recording media previously used for electronic records containing sensitive, proprietary, or national security information are not reused if the previously recorded information can be compromised by reuse in any way.

(c) Agencies shall establish and implement procedures that specifically address the destruction of electronic records generated by individuals employing electronic mail.

[55 FR 19218, May 8, 1990. Redesignated and amended at 60 FR 44641, 44642, Aug. 28, 1995]

## PART 1236—MANAGEMENT OF VITAL RECORDS

### Subpart A—General

Sec.  
1236.10 Purpose.  
1236.12 Authority.  
1236.14 Definitions.

### Subpart B—Vital Records

1236.20 Vital records program objectives.  
1236.22 Identification of vital records.  
1236.24 Use of vital records and copies of vital records.  
1236.26 Protection of vital records.  
1236.28 Disposition of original vital records.

AUTHORITY: 44 U.S.C. 2104(a), 2904(a), 3101; E. O. 12656, 53 FR 47491, 3 CFR, 1988 Comp., p. 585.

SOURCE: 60 FR 29990, June 7, 1995, unless otherwise noted.

### Subpart A—General

#### § 1236.10 Purpose.

This part prescribes policies and procedures for establishing a program for the identification and protection of vital records, those records needed by agencies for continuity of operations

before, during, and after emergencies, and those records needed to protect the legal and financial rights of the Government and persons affected by Government activities. The records may be maintained on a variety of media including paper, magnetic tape or disk, photographic film, and microfilm. The management of vital records is part of an agency's continuity of operations plan designed to meet emergency management responsibilities.

**§ 1236.12 Authority.**

Heads of agencies are responsible for the vital records program under the following authorities:

(a) To make and preserve records containing adequate and proper documentation of the agency's organization, functions, policies, procedures, decisions, and essential transactions, and to furnish information to protect the legal and financial rights of the Government and of persons directly affected by the agency's activities (44 U.S.C. 3101).

(b) To perform national security emergency preparedness functions and activities (Executive Order 12656).

**§ 1236.14 Definitions.**

Basic records management terms are defined in 36 CFR 1220.14. As used in part 1236:

*Contingency planning* means instituting policies and procedures to mitigate the effects of potential emergencies or disasters on an agency's operations and records. Contingency planning is part of the continuity of operations planning required under Federal Preparedness Circulars and other guidance issued by the Federal Emergency Management Agency (FEMA) and Executive Order 12656.

*Cycle* means the periodic removal of obsolete copies of vital records and their replacement with copies of current vital records. This may occur daily, weekly, quarterly, annually or at other designated intervals.

*Disaster* means an unexpected occurrence inflicting widespread destruction and distress and having long-term adverse effects on agency operations. Each agency defines what a long-term adverse effect is in relation to its most critical program activities.

*Emergency* means a situation or an occurrence of a serious nature, developing suddenly and unexpectedly, and demanding immediate action. This is generally of short duration, for example, an interruption of normal agency operations for a week or less. It may involve electrical failure or minor flooding caused by broken pipes.

*Emergency operating records* are that type of vital records essential to the continued functioning or reconstitution of an organization during and after an emergency. Included are emergency plans and directive(s), orders of succession, delegations of authority, staffing assignments, selected program records needed to continue the most critical agency operations, as well as related policy or procedural records that assist agency staff in conducting operations under emergency conditions and for resuming normal operations after an emergency.

*Legal and financial rights records* are that type of vital records essential to protect the legal and financial rights of the Government and of the individuals directly affected by its activities. Examples include accounts receivable records, social security records, payroll records, retirement records, and insurance records. These records were formerly defined as "rights-and-interests" records.

*National security emergency* means any occurrence, including natural disaster, military attack, technological emergency, or other emergency, that seriously degrades or threatens the national security of the United States, as defined in Executive Order 12656.

*Off-site storage* means a facility other than an agency's normal place of business where vital records are stored for protection. This is to ensure that the vital records are not subject to damage or destruction from an emergency or disaster affecting an agency's normal place of business.

*Vital records* mean essential agency records that are needed to meet operational responsibilities under national security emergencies or other emergency or disaster conditions (emergency operating records) or to protect the legal and financial rights of the



Government and those affected by Government activities (legal and financial rights records).

*Vital records program* means the policies, plans, and procedures developed and implemented and the resources needed to identify, use, and protect the essential records needed to meet operational responsibilities under national security emergencies or other emergency or disaster conditions or to protect the Government's rights or those of its citizens. This is a program element of an agency's emergency management function.

### Subpart B—Vital Records

#### § 1236.20 Vital records program objectives.

The vital records program is conducted to identify and protect those records that specify how an agency will operate in case of emergency or disaster, those records vital to the continued operations of the agency during and after an emergency or disaster, and records needed to protect the legal and financial rights of the Government and of the persons affected by its actions. An agency identifies vital records in the course of contingency planning activities carried out in the context of the emergency management function. In carrying out the vital records program agencies shall:

- (a) Specify agency staff responsibilities;
- (b) Ensure that all concerned staff are appropriately informed about vital records;
- (c) Ensure that the designation of vital records is current and complete; and
- (d) Ensure that vital records and copies of vital records are adequately protected, accessible, and immediately usable.

#### § 1236.22 Identification of vital records.

Vital records include emergency plans and related records that specify how an agency is to respond to an emergency as well as those records that would be needed to continue operations and protect legal and financial rights. Agencies should consider the informational content of records series

and electronic records systems when identifying vital records. Only the most recent and complete source of the vital information needs to be treated as vital records.

#### § 1236.24 Use of vital records and copies of vital records.

Agencies shall ensure that retrieval procedures for vital records require only routine effort to locate needed information, especially since individuals unfamiliar with the records may need to use them during an emergency or disaster. Agencies also shall ensure that all equipment needed to read vital records or copies of vital records will be available in case of emergency or disaster. For electronic records systems, agencies also shall ensure that system documentation adequate to operate the system and access the records will be available in case of emergency or disaster.

#### § 1236.26 Protection of vital records.

Agencies shall take appropriate measures to ensure the survival of the vital records or copies of vital records in case of emergency or disaster. In the case of electronic records, this requirement is met if the information needed in the event of emergency or disaster is available in a copy made for general security purposes, even when the copy contains other information.

(a) *Duplication.* Computer backup tapes created in the normal course of system maintenance or other electronic copies that may be routinely created in the normal course of business may be used as the vital record copy. For hard copy records, agencies may choose to make microform copies. Standards for the creation, preservation and use of microforms are found in 36 CFR part 1230, Micrographic Records Management. The Clinger-Cohen Act (40 U.S.C. 1401, Pub. L. 104-106, *et seq.*, as amended by Pub. L. 104-208), OMB Circular A-130, and 36 CFR part 1234, Electronic Records Management, and 41 CFR part 201, subchapter B, Management and Use of Information and Records, specify protective measures and standards for electronic records.

(b) *Storage.* When agencies choose duplication as a protection method, the copy of the vital record stored off-site

## § 1236.28

is normally a duplicate of the original record. Designating and using duplicate copies of original records as vital records facilitates destruction or deletion of obsolete duplicates when replaced by updated copies, whereas original vital records must be retained for the period specified in the agency records disposition schedule. The agency may store the original records off-site if protection of original signatures is necessary, or if it does not need to keep the original record at its normal place of business.

(c) *Storage considerations.* Agencies need to consider several factors when deciding where to store copies of vital records. Copies of emergency operating vital records need to be accessible in a very short period of time for use in the event of an emergency or disaster. Copies of legal and financial rights records may not be needed as quickly. In deciding where to store vital records copies, agencies shall treat records that have the properties of both categories, that is, emergency operating and legal and financial rights records, as emergency operating records.

(1) Under certain circumstances, Federal records centers (FRC's) may store copies of emergency operating vital records. FRC's will store small volumes of such records, but may not be able to provide storage for large collections or ones requiring constant recycling of the vital records, except under reimbursable agreement. Prior to preparing the records for shipment, the agency must contact the FRC to determine if the center can accommodate the storage requirements and return copies in an acceptable period of time.

(2) The off-site copy of legal and financial rights vital records may be stored at an off-site agency location or, in accordance with §1228.162 of this chapter, at an FRC.

(3) When using an FRC for storing vital records that are duplicate copies of original records, the agency must specify on the SF 135, Records Transmittal and Receipt, that they are vital records (duplicate copies) and the medium on which they are maintained. The agency shall also periodically cycle (update) them by removing obsolete items and replacing them with the most recent version, when necessary.

## 36 CFR Ch. XII (7-1-03 Edition)

(4) Agencies that transfer permanent, original vital records maintained on electronic or microform media to the custody of the National Archives may designate such records as their off-site copy. That designation may remain in effect until the information in such transferred records is superseded or becomes obsolete.

[60 FR 29990, June 7, 1995, as amended at 66 FR 27028, May 16, 2001]

### § 1236.28 Disposition of original vital records.

The disposition of original vital records is governed by records schedules approved by NARA (see part 1228, Disposition of Federal Records). Original records that are not scheduled may not be destroyed or deleted.

## PART 1238—PROGRAM ASSISTANCE

Sec.

1238.1 Scope of part.

1238.2 Requests for assistance.

AUTHORITY: 44 U.S.C. 2904 and 3101.

### § 1238.1 Scope of part.

The National Archives and Records Administration publishes handbooks, conducts workshops and other training sessions, and furnishes information and guidance to Federal agencies about the creation of records, their maintenance and use, and their disposition.

[50 FR 26940, June 28, 1985]

### § 1238.2 Requests for assistance.

Agencies desiring information or assistance related to any of the areas covered by subchapter B should contact the NARA Life Cycle Management Division (NWML), 8601 Adelphi Rd., College Park, MD 20740-6001. Agency field organizations may contact the appropriate Regional Administrator regarding records in or scheduled for transfer to the records center and/or the archival operations within the region.

[57 FR 19807, May 8, 1992, as amended at 63 FR 35830, July 1, 1998]

## SUBCHAPTER C—PUBLIC AVAILABILITY AND USE

### PART 1250—PUBLIC AVAILABILITY AND USE OF FEDERAL RECORDS

#### Subpart A—General Information About Freedom of Information Act (FOIA) Requests

Sec.

- 1250.1 Scope of this part.
- 1250.2 Definitions.
- 1250.4 Who can file a FOIA request?
- 1250.6 Does FOIA cover all of the records at NARA?
- 1250.8 Does NARA provide access to all the executive branch records housed at NARA facilities?
- 1250.10 Do I need to use FOIA to gain access to records at NARA?
- 1250.12 What types of records are available in NARA's FOIA Reading Room?
- 1250.14 If I do not use FOIA to request records, will NARA treat my request differently?

#### Subpart B—How to Access Records Under FOIA

- 1250.20 What do I include in my FOIA request?
- 1250.22 Where do I send my FOIA request?
- 1250.24 Will you accept a FOIA request through email?
- 1250.26 How quickly will NARA respond to my FOIA request?
- 1250.28 Will NARA ever expedite the review of the records I requested?
- 1250.30 How do I request expedited processing?
- 1250.32 How quickly will NARA process an expedited request?
- 1250.34 How will I know if NARA is going to release the records I requested?
- 1250.36 When will NARA deny a FOIA request?
- 1250.38 In what format will NARA provide copies?

#### Subpart C—Fees

- 1250.50 Will I be charged for my FOIA request?
- 1250.52 How much will I have to pay for a FOIA request for NARA operational records?
- 1250.54 General information on fees for NARA operational records.
- 1250.56 Fee schedule for NARA operational records.
- 1250.58 Does NARA ever waive FOIA fees for NARA operational records?
- 1250.60 How will NARA determine if I am eligible for a fee waiver for NARA operational records?

#### Subpart D—Appeals

- 1250.70 What are my appeal rights under FOIA?
- 1250.72 How do I file an appeal?
- 1250.74 Where do I send my appeal?
- 1250.76 May I email my FOIA appeal?
- 1250.78 How does NARA handle appeals?

#### Subpart E—Special Situations

- 1250.80 How does a submitter identify records containing confidential commercial information?
- 1250.82 How will NARA handle a FOIA request for confidential commercial information?
- 1250.84 Service of subpoena or other legal demand for NARA operational records.

AUTHORITY: 44 U.S.C. 2104(a), 2204; 5 U.S.C. 552; E.O. 12600, 52 FR 23781, 3 CFR, 1987 Comp., p. 235.

SOURCE: 66 FR 16376, Mar. 23, 2001, unless otherwise noted.

#### Subpart A—General Information About Freedom of Information Act (FOIA) Requests

##### § 1250.1 Scope of this part.

This part implements the provisions of the Freedom of Information Act (FOIA), 5 U.S.C. 552, as amended, for NARA operational records and archival records that are subject to FOIA. Other NARA regulations in 36 CFR parts 1254 through 1275 provide detailed guidance for conducting research at NARA.

##### § 1250.2 Definitions.

The following definitions apply to this part:

(a) *Archival records* means permanently valuable records of the United States Government that have been transferred to the legal custody of the Archivist of the United States.

(b) *Commercial use requester* means a requester seeking information for a use or purpose that furthers the commercial, trade, or profit interests of the requester or the person on whose behalf the request is made.

(c) *Confidential commercial information* means records provided by a submitter that may contain material exempt from release under the FOIA because

**§ 1250.4**

**36 CFR Ch. XII (7-1-03 Edition)**

disclosure could reasonably be expected to cause the submitter substantial competitive harm.

(d) *Educational institution request* means a preschool, a public or private elementary or secondary school, an institution of undergraduate higher education, an institution of graduate higher education, an institution of professional education, or an institution of vocational education, that operates a program of scholarly research. To be in this category, a requester must show that the request is authorized by and is made under the auspices of a qualifying institution and that the records are not sought for a commercial use but are sought to further scholarly research.

(e) *FOIA request* means a written request for access to records of the executive branch of the Federal Government held by NARA, including NARA operational records, or to Presidential records in the custody of NARA that were created after January 19, 1981, that cites the Freedom of Information Act.

(f) *Freelance journalist* means an individual who qualifies as a representative of the news media because the individual can demonstrate a solid basis for expecting publication through a news organization, even though not actually in its employ. A publication contract would be the clearest proof of a solid basis, but the individual's publication history may also be considered in demonstrating this solid basis.

(g) *News media representative* means a person actively gathering news for an entity that is organized and operated to publish or broadcast news to the public. The term "news" means information that is about current events or that would be of current interest to the public. Examples of news media entities include television or radio stations broadcasting to the public at large, and publishers of periodicals (but only in those instances when they can qualify

as disseminators of news) who make their products available for purchase or subscription to the general public.

(h) *Non-commercial scientific institution* means an institution that is not operated on a basis that furthers the commercial, trade, or profit interests of any person or organization, and which is operated solely for the purpose of conducting scientific research which produces results that are not intended to promote any particular product or industry.

(i) *Operational records* means those records that NARA creates or receives in carrying out its mission and responsibilities as an executive branch agency. This does not include archival records as defined in paragraph (a) of this section.

(j) *Other requesters* means any individual who is not a commercial-use requester, not a representative of the news media, not a freelance journalist, nor one associated with an educational or non-commercial scientific institution whose research activities conform to the definition in paragraph (h) of this section.

(k) *Submitter* means any person or entity providing potentially confidential commercial information to an agency. The term submitter includes, but is not limited to, corporations, state governments, and foreign governments.

**§ 1250.4 Who can file a FOIA request?**

Any individual, partnership, corporation, association, or government regardless of nationality may file a FOIA request.

**§ 1250.6 Does FOIA cover all of the records at NARA?**

No, FOIA applies only to the records of the executive branch of the Federal government and certain Presidential records. Use the following chart to determine how to gain access:

IF YOU WANT ACCESS TO ...	THEN ACCESS IS GOVERNED BY . . .
(A) Records of executive branch agencies	This part and parts 1254 through 1260 of this chapter. FOIA applies to these records.

IF YOU WANT ACCESS TO ...	THEN ACCESS IS GOVERNED BY . . .
(B) Records of the Federal courts	Parts 1254 through 1260 of this chapter. FOIA does not apply to these records.
(C) Records of Congress	Parts 1254 through 1260 of this chapter. FOIA does not apply to these records.
(D) Presidential records (created by Presidents holding office since 1981).	This part and parts 1254 through 1270 of this chapter. FOIA applies to these records 5 years after the President leaves office. However a President may invoke exemptions under the Presidential Records Act which would extend this up to 12 years after the President leaves office.
(E) Documents created by Presidents holding office before 1981 and housed in a NARA Presidential library.	The deed of gift under which they were given to NARA. These documents are not Federal records and FOIA does not apply to these materials.
(F) Nixon Presidential materials	Part 1275 of this chapter. FOIA does not apply to these materials.

**§ 1250.8 Does NARA provide access to all the executive branch records housed at NARA facilities?**

(a) NARA provides access to the records NARA creates (operational records) and records originating in other Federal agencies that have been transferred to the legal custody of the Archivist of the United States (archival records).

(b) Twentieth-century personnel and medical records of former members of the military and of former civilian employees of the Federal government are held at NARA's National Personnel Records Center (NPRC), located in St. Louis, Missouri. These records remain in the legal custody of the agencies that created them and access to them is governed by the FOIA and other access regulations of the creating agencies. The NPRC processes FOIA requests under authority delegated by the originating agencies, not under the provisions of this part.

(c) In our national and regional records centers, NARA stores records that agencies no longer need for day-

to-day business. These records remain in the legal custody of the agencies that created them. Access to these records is through the originating agency. NARA does not process FOIA requests for these records.

**§ 1250.10 Do I need to use FOIA to gain access to records at NARA?**

(a) Most archival records held by NARA are available to the public for research without filing a FOIA request. You may either visit a NARA facility as a researcher to view and copy records or you may write to request copies of specific records.

(b) If you are seeking access to archival records that are restricted and not available to the public, you may need to file a FOIA request or a mandatory review request (see part 1254 of this chapter for procedures for accessing classified records) to gain access to these materials. If you make a reference request for restricted records, we may ask that you change your reference request to a FOIA request or a mandatory review request. See 36 CFR

## § 1250.12

1254.46 for information on filing mandatory review requests.

(c) You must file a FOIA request when you request access to NARA operational records that are not already available to the public.

### § 1250.12 What types of records are available in NARA's FOIA Reading Room?

(a) NARA makes available for public inspection and copying the following materials described in subsection (a)(2) of the FOIA:

(1) Final NARA orders;

(2) Written statements of NARA policy that are not published in the Federal Register;

(3) Operational staff manuals and instructions to staff that affect members of the public;

(4) Copies of records requested 3 or more times under FOIA and other records that have been or are likely to become the subject of subsequent FOIA requests for substantially the same records;

(5) An index, updated quarterly, to these materials.

(b) These materials are available during normal working hours at the NARA facility where the records are located. See 36 CFR parts 1253 and 1254 for a fuller description of NARA facilities and research room procedures.

(c) Any of this material that was created after October 31, 1996, will also be placed on NARA's web site at [http://www.archives.gov/research\\_room/foia\\_reading\\_room/foia\\_reading\\_room.html](http://www.archives.gov/research_room/foia_reading_room/foia_reading_room.html).

(d) For paper copies of the index to these materials write the NARA FOIA Officer at the address listed in § 1250.22(d).

[66 FR 16376, Mar. 23, 2001, as amended at 67 FR 43253, June 27, 2002]

### § 1250.14 If I do not use FOIA to request records, will NARA treat my request differently?

Whether you choose to invoke the FOIA or not, NARA will respond as promptly as possible to your request.

## 36 CFR Ch. XII (7-1-03 Edition)

### Subpart B—How To Access Records Under FOIA

#### § 1250.20 What do I include in my FOIA request?

In your FOIA request, you must:

(a) Describe the records you wish to access in enough detail to allow NARA staff to find them. The more information you provide, the better possibility NARA has of finding the records you are seeking. Information that will help us find the records includes:

(1) The agencies, offices, or individuals involved; and

(2) The approximate date when the records were created.

(b) Include your name and full mailing address. If possible, please include a phone number or email address as well. This information will allow us to reach you faster if we have any questions about your request.

(c) Mark both your letter and envelope with the words "FOIA Request."

#### § 1250.22 Where do I send my FOIA request?

(a) For requests for archival records in the Washington, DC, area, mail your request to the Chief, Special Access and FOIA Staff (NWCTF), Room 6350, National Archives and Records Administration, 8601 Adelphi Road, College Park, MD 20740-6001.

(b) For archival records in any of NARA's regional records services facilities, send the FOIA request to the director of the facility in which the records are located. The addresses for these facilities are listed in 36 CFR 1253.7.

(c) For Presidential records subject to FOIA, mail your request to the director of the library in which the records are located. The addresses for these facilities are listed in 36 CFR 1253.3.

(d) For the operational records of any NARA unit except the Office of the Inspector General, mail your request to the NARA FOIA Officer (NGC), Room 3110, National Archives and Records Administration, 8601 Adelphi Road, College Park, MD 20740-6001.

(e) For records of the Inspector General write to Office of the Inspector General (OIG), FOIA Request, Room 1300, National Archives and Records

Administration, 8601 Adelphi Road, College Park, MD 20740-6001.

(f) If you are unable to determine where to send your request, send it to the NARA FOIA Officer (NGC), Room 3110, National Archives and Records Administration, 8601 Adelphi Road, College Park, MD 20740-6001. That office will forward your request to the office(s) that have the records you are seeking. Your request will be considered received when it reaches the proper office's FOIA staff.

**§ 1250.24 Will you accept a FOIA request through email?**

Yes, send email FOIA requests to [http://www.archives.gov/global\\_pages/inquire\\_form.html](http://www.archives.gov/global_pages/inquire_form.html). You must indicate in the subject line of your email message that you are sending a FOIA request. The body of the message must contain all of the information listed in § 1250.20.

[66 FR 16376, Mar. 23, 2001, as amended at 67 FR 43253, June 27, 2002]

**§ 1250.26 How quickly will NARA respond to my FOIA request?**

(a) NARA will make an initial response to all FOIA requests within 20 working days. The initial response will inform requesters of any complexity in processing their request, which may lengthen the time required to reach a final decision on the release of the records.

(b) In most cases, NARA will make a decision on the release of the records you requested within the 20 working days. If unusual circumstances prevent us from making a decision within 20 working days, we will inform you in writing how long it will take us to complete your request. Unusual circumstances are the need to:

(1) Search for and collect the records from field facilities;

(2) Search for, collect, and review a voluminous amount of records which are part of a single request; or

(3) Consult with another agency before releasing records.

(c) If we are extending the deadline for more than an additional 10 working days, we will ask you if you wish to modify your request so that we can meet the deadline. If you do not agree to modify your request, we will work

with you to arrange an alternative time schedule for review and release.

(d) If you have requested records that we do not have the authority to release without consulting another agency (e.g. security-classified records), we will refer copies of the documents to the appropriate agency. NARA will send you an initial response to your FOIA requests within 20 working days informing you of this referral. However, the final response to your FOIA can only be made when the agency to which we have referred the documents responds to us.

(e) If you have requested Presidential records and NARA decides to grant you access, NARA must inform the incumbent and former Presidents of our intention to disclose information from those records. After receiving the notice, the incumbent and former Presidents have 30 days in which to decide whether or not to invoke Executive privilege to deny access to the information. NARA will send you an initial response to your FOIA request within 20 working days informing you of the status of your request. However, the final response to your FOIA can only be made at the end of the 30-day Presidential notification period.

(f) If you have requested records containing confidential commercial information that is less than 10 years old, we will contact the submitter of the requested information. NARA will send you an initial response to your FOIA request within 20 working days informing you of our actions. See § 1250.82 for the time allowed the submitter to object to the release of confidential commercial information. If the records contain confidential commercial information that is 10 years old or older, NARA staff will not contact the submitter, but will process the request under normal FOIA procedures.

**§ 1250.28 Will NARA ever expedite the review of the records I requested?**

(a) In certain cases NARA will move your FOIA request or appeal to the head of our FOIA queue. We will do this for any of the following reasons:

(1) A reasonable expectation of an imminent threat to an individual's life or physical safety;

**§ 1250.30**

(2) A reasonable expectation of an imminent loss of a substantial due process right; or

(3) An urgent need to inform the public about an actual or alleged Federal government activity (this last criterion applies only to those requests made by a person primarily engaged in disseminating information to the public).

(b) NARA can expedite requests, or segments of requests, only for records over which we have control. If NARA must refer a request to another agency, we will so inform you and suggest that you seek expedited review from that agency. We cannot expedite requests for Presidential records or shorten the 30-day Presidential notification period.

**§ 1250.30 How do I request expedited processing?**

You must submit a statement, certified to be true and correct to the best of your knowledge, explaining the basis of your need for expedited processing. All such requests must be sent to the appropriate official at the address listed in § 1250.22. You may request expedited processing when you first request records or at any time during our processing of your request.

**§ 1250.32 How quickly will NARA process an expedited request?**

We will respond to you within 10 days of our receipt of your request for expedited processing. If we grant your request, the NARA office responsible for the review of the requested records will process your request as quickly as possible. If we deny your request for expe-

ditied processing and you decide to appeal our denial, we will also expedite our review of your appeal.

**§ 1250.34 How will I know if NARA is going to release the records I requested?**

Once NARA decides to release the requested records, in whole or in part, we will inform you in writing. Our response will tell you how much responsive material we found, where you may review the records, and the copying or other charges due. If the records you sought were released only in part, we will estimate, if possible, the amount of the withheld information. Also, if we deny any part of your request, our response will explain the reasons for the denial, which FOIA exemptions apply, and your right to appeal our decisions.

**§ 1250.36 When will NARA deny a FOIA request?**

The FOIA contains nine exemptions under which information may be exempted from release. Given the age and nature of archival records, many of these exemptions apply to only a few of the records in our custody. We will only withhold information where we must (such as information which remains classified, or information which is specifically closed by statute) or we reasonably foresee that disclosure would cause a harm. In addition if only part of a record must be withheld, NARA will provide access to the rest of the information in the record. Categories of information that may be exempt from disclosure under the FOIA are as follows:

SECTION OF THE FOIA:	REASON FOR EXEMPTION:
5 U.S.C. 552(b)(1)	Specifically authorized under criteria established by an Executive order to be kept secret in the interest of national defense or foreign policy and are in fact properly classified under the Executive order.
5 U.S.C. 552(b)(2)	Related solely to the internal personnel rules and practices of an agency.



SECTION OF THE FOIA:	REASON FOR EXEMPTION:
5 U.S.C. 552(b)(3)	Specifically exempted from disclosure by statute (other than section 552b of this title), provided that the statute: (A) Requires that the matters be withheld from the public in such a manner as to leave no discretion on the issue; or (B) Establishes particular criteria for withholding or refers to particular types of matters to be withheld.
5 U.S.C. 552(b)(4)	Trade secrets and commercial or financial information obtained from a person that are privileged or confidential.
5 U.S.C. 552(b)(5)	Inter-agency or intra-agency memorandums or letters which would not be available by law to a party other than an agency in litigation with the agency.
5 U.S.C. 552(b)(6)	Personnel and medical files and similar files the disclosure of which would constitute a clearly unwarranted invasion of personal privacy.
5 U.S.C. 552(b)(7)	Records or information compiled for law enforcement purposes, but only to the extent that the production of such law enforcement records or information: (A) Could reasonably be expected to interfere with enforcement proceedings; (B) Would deprive a person of a right to a fair trial or an impartial adjudication; (C) Could reasonably be expected to constitute an unwarranted invasion of personal privacy; (D) Could reasonably be expected to disclose the identity of a confidential source, including a State, local, or foreign agency or authority or any private institution which furnished information on a confidential basis, and, in the case of a record or information compiled by a criminal law enforcement authority in the course of a criminal investigation, or by an agency conducting lawful national security intelligence investigation, information furnished by a confidential source; (E) Would disclose techniques and procedures for law enforcement investigations or prosecutions, or would disclose guidelines for law enforcement investigations or prosecutions if such disclosure could reasonably be expected to risk circumvention of the law; or (F) Could reasonably be expected to endanger the life or physical safety of any individual.

SECTION OF THE FOIA:	REASON FOR EXEMPTION:
5 U.S.C. 552(b)(8)	Contained in or related to examination, operating, or condition reports prepared by, on behalf of, or for the use of an agency responsible for the regulation or supervision of financial institutions.
5 U.S.C. 552(b)(9)	Geological and geophysical information and data, including maps, concerning wells.

**§ 1250.38 In what format will NARA provide copies?**

After all applicable fees are paid, NARA will provide you copies of records in the format you request if the records already exist in that format, or if they are readily reproducible in the format you request.

**Subpart C—Fees**

**§ 1250.50 Will I be charged for my FOIA request?**

(a) Fees and fee waivers for FOIA requests for NARA operational records are listed in this subpart.

(b) Fees for FOIA requests for NARA archival records are listed in 36 CFR part 1258.

**§ 1250.52 How much will I have to pay for a FOIA request for NARA operational records?**

(a) If you are a commercial use requester, we will charge you fees for searching, reviewing, and copying.

(b) If you are an educational or scientific institution requester, or a member of the news media, we will charge you fees for copying. However, we will not charge you for copying the first 100 pages.

(c) If you do not fall into either of the categories in paragraphs (a) and (b) of this section, then we will charge you search and copying fees. However, we will not charge you for the first 2 hours of search time or for copying the first 100 pages.

**§ 1250.54 General information on fees for NARA operational records.**

(a) NARA is able to make most of its records available for examination at

the NARA facility where the records are located. Whenever this is possible, you may review the records in a NARA research room at that facility.

(b) If you want NARA to supply you with copies, we will normally require you to pay all applicable fees in accordance with § 1250.52 before we provide you with the copies.

(c) NARA may charge search fees even if the records are not releasable or even if we do not find any responsive records during our search.

(d) If you are entitled to receive 100 free pages, but the records cannot be copied onto standard size (8.5" by 11") photocopy paper, we will copy them on larger paper and will reduce your copy fee by the normal charge for 100 standard size photocopies. If the records are not on textual media (e.g., photographs or electronic files) we will provide the equivalent of 100 pages of standard size paper copies for free.

(e) We will not charge you any fee if the total costs are \$10 or less.

(f) If estimated search or review fees exceed \$50, we will contact you. If you have specified a different limit that you are willing to spend, we will contact you only if we estimate the fees will exceed that amount.

(g) If you have failed to pay FOIA fees in the past, we will require you to pay your past-due bill before we begin processing your request. If we estimate that your fees may be greater than \$250, we may require payment or a deposit before we begin processing your request.

(h) If we determine that you (acting either alone or with others) are breaking down a single request into a series of requests in order to avoid or reduce

fees, we may aggregate all these requests in calculating the fees.

**§ 1250.56 Fee schedule for NARA operational records.**

In responding to FOIA requests for operational records, NARA will charge the following fees, where applicable, unless we have given you a reduction or waiver of fees under § 1250.60.

(a) *Search fees*—(1) *Manual searching of records.* When the search is relatively straightforward and can be performed by a clerical or administrative employee, the search rate is \$16 per hour (or fraction thereof). When the request is more complicated and must be done by a professional employee of NARA, the rate is \$33 per hour (or fraction thereof)

(2) *Computer searching.* This is the actual cost to NARA of operating the computer and the salary of the operator. When the search is relatively straightforward and can be performed by a clerical or administrative employee, the search rate is \$16 per hour (or fraction thereof). When the request is more complicated and must be done by a professional employee of NARA, the rate is \$33 per hour (or fraction thereof).

(b) *Review fees.* (1) Review fees are charged for time spent examining all documents that are responsive to a request to determine if any are exempt from release and to determine if NARA will release exempted records.

(2) The review fee is \$33 per hour (or fraction thereof).

(3) NARA will not charge review fees for time spent resolving general legal or policy issues regarding the application of exemptions.

(c) *Reproduction fees*—(1) *Self-service photocopying.* At NARA facilities with self-service photocopiers, you may make reproductions of released paper documents for 15 cents per page.

(2) *Photocopying standard size pages.* This charge is 20 cents per page when NARA produces the photocopies.

(3) *Reproductions of electronic records.* The direct costs to NARA for staff time for programming, computer operations, and printouts or electromagnetic media to reproduce the requested information will be charged to requesters. When the work is relatively straight-

forward and can be performed by a clerical or administrative employee, the rate is \$16 per hour (or fraction thereof). When the request is more complicated and must be done by a professional employee of NARA, the rate is \$33 per hour (or fraction thereof).

(4) *Copying other media.* This is the direct cost to NARA of the reproduction. Specific charges will be provided upon request.

**§ 1250.58 Does NARA ever waive FOIA fees for NARA operational records?**

(a) NARA will waive or reduce your fees for NARA operational records only if your request meets both of the following criteria:

(1) The request is in the public interest (i.e., information likely to contribute significantly to public understanding of the operations and activities of the government); and

(2) The request is not primarily in your commercial interest.

(b) All requests for fee waivers or reductions must be made at the time of the initial FOIA request. All requests must include the grounds for requesting the reduction or elimination of fees.

**§ 1250.60 How will NARA determine if I am eligible for a fee waiver for NARA operational records?**

(a) If you request a fee waiver, NARA will consider the following in reviewing how your request meets the public interest criteria in § 1250.58(a)(1):

(1) How do the records pertain to the operations and activities of the Federal Government?

(2) Will release reveal any meaningful information about Federal Government activities that is not already publicly known?

(3) Will disclosure to you advance the understanding of the general public on the issue?

(4) Do you have expertise in or a thorough understanding of these records?

(5) Will you be able to disseminate this information to a broad spectrum of the public?

(6) Will disclosure lead to a significantly greater understanding of the Government by the public?

## § 1250.70

(b) After reviewing your request and determining that there is a substantial public interest in release, NARA will also review it to determine if it furthers your commercial interests. If it does, you are not eligible for a fee waiver.

### Subpart D—Appeals

#### § 1250.70 What are my appeal rights under FOIA?

You may appeal any of the following decisions:

(a) The refusal to release a record, either in whole or in part;

(b) The determination that a record does not exist or cannot be found;

(c) The determination that the record you sought was not subject to the FOIA;

(d) The denial of a request for expedited processing; or

(e) The denial of a fee waiver request.

#### § 1250.72 How do I file an appeal?

(a) All appeals must be in writing and received by NARA within 35 calendar days of the date of NARA's denial letter. Mark both your letter and envelope with the words "FOIA Appeal," and include a copy of your initial request and our denial.

(b) In your appeal, explain why we should release the records, grant your fee waiver request, or expedite the processing of your request. If we were not able to find the records you wanted, explain why you believe our search was inadequate. If we denied you access to records and told you that those records were not subject to FOIA, please explain why you believe the records are subject to FOIA.

#### § 1250.74 Where do I send my appeal?

(a) If NARA's Inspector General denied your request, send your appeal to the Archivist of the United States, (ATTN: FOIA Appeal Staff), Room 4200, National Archives and Records Administration, 8601 Adelphi Road, College Park, Maryland 20740-6001.

(b) Send all other appeals to the Deputy Archivist of the United States, (ATTN: FOIA Appeal Staff), Room 4200, National Archives and Records Admin-

## 36 CFR Ch. XII (7-1-03 Edition)

istration, 8601 Adelphi Road, College Park, Maryland 20740-6001.

(c) Denials under FOIA of access to national security information accessioned into the National Archives of the United States are made by designated officials of the originating or responsible agency or by NARA under a written delegation of authority. You must appeal determinations that records remain classified for reasons of national security to the agency with responsibility for protecting and declassifying that information. NARA will provide you with the necessary appeal information in those cases. You can find additional information on access to national security classified records at NARA in 36 CFR part 1254.

#### § 1250.76 May I email my FOIA appeal?

Yes, you may submit a FOIA appeal via email to [http://www.archives.gov/global\\_pages/inquire\\_form.html](http://www.archives.gov/global_pages/inquire_form.html). You must put the words "FOIA Appeal" in the subject line of your email message. The body of your message must contain the information in § 1250.72(b).

[66 FR 16376, Mar. 23, 2001, as amended at 67 FR 43253, June 27, 2002]

#### § 1250.78 How does NARA handle appeals?

NARA will respond to your appeal within 20 working days after its receipt of the appeal by NARA. If we reverse or modify our initial decision, we will inform you in writing and reprocess your request. If we do not change our initial decision, our response to you will explain the reasons for our decision, any FOIA exemptions that apply, and your right to judicial review of our decision.

### Subpart E—Special Situations

#### § 1250.80 How does a submitter identify records containing confidential commercial information?

When a person submits records that contain confidential commercial information to NARA, that person may state in writing that all or part of the records are exempt from disclosure under exemption (b)(4) of the FOIA.

**§ 1250.82 How will NARA handle a FOIA request for confidential commercial information?**

If NARA receives a FOIA request for records containing confidential commercial information or for records that we believe may contain confidential commercial information and if the information is less than 10 years old, we will follow these procedures:

(a) If, after reviewing the records in response to a FOIA request, we believe that the records may be opened, we will make reasonable efforts to inform the submitter of this. When the request is for information from a single or small number of submitters, NARA will send a notice via registered mail to the submitter's last known address. Our notice to the submitter will include a copy of the FOIA request and will tell the submitter the time limits and procedures for objecting to the release of the requested material.

(b) The submitter will have 5 working days from the receipt of our notice to object to the release and to explain the basis for the objection. The NARA FOIA Officer may extend this period for an additional 5 working days.

(c) NARA will review and consider all objections to release that are received within the time limit. If we decide to release the records, we will inform the submitter in writing. This notice will include copies of the records as we intend to release them and our reasons for deciding to release. We will also inform the submitter that we intend to release the records 10 working days after the date of the notice unless a U.S. District Court forbids disclosure.

(d) If the requester files a lawsuit under the FOIA for access to any withheld records, we will inform the submitter.

(e) We will notify the requester whenever we notify the submitter of the opportunity to object or to extend the time for objecting.

**§ 1250.84 Service of subpoena or other legal demand for NARA operational records.**

(a) A subpoena duces tecum or other legal demand for the production of NARA operational records must be addressed to the Office of the General Counsel (NGC), Room 3110, National

Archives and Records Administration, 8601 Adelphi Road, College Park, MD, 20740-6001.

(b) The Archivist of the United States and the General Counsel are the only NARA employees authorized to accept, on behalf of NARA, service of a subpoena duces tecum or other legal demands for NARA operational records.

(c) Regulations concerning service of a subpoena duces tecum or other legal demand for archival records accessioned into the National Archives of the United States, records of other agencies in the custody of the Federal records centers, and donated historical materials are located at 36 CFR 1254.8.

**PART 1252—PUBLIC USE OF RECORDS, DONATED HISTORICAL MATERIALS, AND FACILITIES; GENERAL**

Sec.

1252.1 Scope.

1252.2 Definitions.

AUTHORITY: 44 U.S.C. 2104(a).

**§ 1252.1 Scope.**

This subchapter prescribes rules and procedures governing the public use of records and donated historical materials in the custody of the National Archives and Records Administration (NARA). Except for part 1250, this subchapter does not apply to current operating records of NARA. This subchapter also prescribes rules and procedures governing the public use of certain NARA facilities.

[59 FR 29191, June 6, 1994]

**§ 1252.2 Definitions.**

The following definitions are established for terms used in this subchapter.

*Archives or archival records* mean Federal records that have been determined by NARA to have sufficient historical or other value to warrant their continued preservation by the U.S. Government, and have been transferred to the National Archives of the United States.

*Director* means the head of a Presidential library, the head of a Presidential Materials Staff, the head of a

NARA division, branch, archival center, or unit responsible for servicing archival records, the head of a regional archives, or the head of a Federal records center.

*Documents* mean, for purposes of part 1254 of this chapter, archives, FRC records, donated historical materials, Nixon Presidential historical materials, and Presidential records, regardless of the media on which they are contained. Document form may include paper, microforms, photographs, sound recordings, motion pictures, maps, drawings, and electronic files.

*Donated historical materials* means books, correspondence, documents, papers, pamphlets, magnetic tapes, pictures, photographs, plats, maps, films, motion pictures, sound recordings, and other documentary media having historical or commemorative value accepted by NARA from a source other than an agency of the U.S. Government.

*Federal records center* includes the Washington National Records Center, the National Personnel Records Center, and the Federal records centers listed in § 1253.6 of this chapter.

*Federal records center records (FRC records)* mean records which, pending their transfer to the National Archives of the United States or their disposition in any other manner authorized by law, have been transferred to a Federal records center operated by NARA.

*Nixon Presidential historical materials* has the meaning specified in § 1275.16 of this chapter.

*Presidential records* has the meaning specified in § 1270.14 of this chapter.

*Records* mean records or microfilm copies of records transferred to NARA under 44 U.S.C. 2107 and 3103; namely, archives and Federal records center records as the terms are defined in § 1252.2. The term *records* does not include current operating records of NARA, the public availability of which is governed by part 1250 of this chapter, or donated historical materials as defined in this section.

*Researcher* means a person who has been granted access to original documents or copies of documents.

[33 FR 4885, Mar. 22, 1968, 42 FR 13022, Mar. 8, 1977, and 49 FR 33253, Aug. 22, 1984. Redesignated and amended at 50 FR 15723, 15726, Apr. 19, 1985; 59 FR 29191, June 6, 1994]

## PART 1253—LOCATION OF RECORDS AND HOURS OF USE

### Sec.

- 1253.1 National Archives Building.
- 1253.2 National Archives at College Park.
- 1253.3 Presidential Libraries.
- 1253.4 Washington National Records Center.
- 1253.5 National Personnel Records Center.
- 1253.6 Records Centers.
- 1253.7 Regional Archives.
- 1253.8 Are NARA research room facilities closed on Federal holidays?

AUTHORITY: 44 U.S.C. 2104(a).

SOURCE: 65 FR 38730, June 22, 2000, unless otherwise noted.

### § 1253.1 National Archives Building.

(a) The National Archives Building is located at 700 Pennsylvania Avenue, NW., Washington, DC 20408. Business hours are 8:45 a.m. to 5:15 p.m., Monday through Friday, except Federal holidays when the building is closed. Hours for the Central Research Room and Microfilm Research Room are as follows, except Federal holidays:

- (1) Monday and Wednesday, 8:45 a.m. to 5 p.m.;
- (2) Tuesday, Thursday, and Friday, 8:45 a.m. to 9 p.m.; and
- (3) Saturday, 8:45 a.m. to 4:45 p.m.

(b) The phone number for the research rooms is 800-234-8861.

(c) The location and business hours of the Office of the Federal Register are located in 1 CFR 2.3.

### § 1253.2 National Archives at College Park.

(a) The National Archives at College Park is located at 8601 Adelphi Road, College Park, MD 20740-6001. Business hours are 8:45 a.m. to 5:15 p.m., Monday through Friday, except Federal holidays when the building is closed.

(b) Research complex hours are as follows, except Federal holidays:

- (1) Monday and Wednesday, 8:45 a.m. to 5 p.m.;
- (2) Tuesday, Thursday, and Friday, 8:45 a.m. to 9 p.m.; and
- (3) Saturday, 8:45 a.m. to 4:45 p.m.

(c) The phone number for the research complex is 800-234-8861.

**§ 1253.3 Presidential Libraries.**

The Presidential libraries are open for research from 9 a.m. to 5 p.m., Monday through Friday, except Federal holidays when they are closed. NARA recommends that researchers contact the library before visiting for research. The Presidential library museums are open every day except Thanksgiving, December 25, and January 1 (with the exception of the Lyndon Baines Johnson Library that is only closed December 25). For more specific information about museum hours, please contact the libraries directly or visit the NARA web site at <http://www.nara.gov/nara/president/address.html>. Information for each library is as follows:

(a) Herbert Hoover Library is located at 210 Parkside Dr., West Branch, IA (mailing address: PO Box 488, West Branch, IA 52358-0488). The phone number is 319-643-5301 and the fax number is 319-643-5825. The e-mail address is [hoover.library@nara.gov](mailto:hoover.library@nara.gov).

(b) Franklin D. Roosevelt Library is located at 4079 Albany Post Rd., Hyde Park, NY 12538-1999. The phone number is 845-486-7770 and the fax number is 845-486-1147. The email address is [roosevelt.library@nara.gov](mailto:roosevelt.library@nara.gov).

(c) Harry S. Truman Library is located at 500 W. US Hwy 24, Independence, MO 64050-1798. The phone number is 816-833-1400 and the fax number is 816-833-4368. The e-mail address is [truman.library@nara.gov](mailto:truman.library@nara.gov).

(d) Dwight D. Eisenhower Library is located at 200 SE Fourth Street, Abilene, KS 67410-2900. The phone number is 785-263-4751 and the fax number is 785-263-4218. The e-mail address is [eisenhower.library@nara.gov](mailto:eisenhower.library@nara.gov).

(e) John Fitzgerald Kennedy Library is located at Columbia Point, Boston, MA 02125-3398. The phone number is 617-514-1600 and the fax number is 617-514-1593. The email address is [kennedy.library@nara.gov](mailto:kennedy.library@nara.gov).

(f) Lyndon Baines Johnson Library is located at 2313 Red River St., Austin, TX 78705-5702. The phone number is 512-721-0200 and the fax number is 512-721-0236. The email address is [johnson.library@nara.gov](mailto:johnson.library@nara.gov).

(g) Gerald R. Ford Museum is located at 303 Pearl St., Grand Rapids, MI 49504-5353. The phone number is 616-451-9263 and the fax number is 616-451-

9570. The e-mail address is [ford.museum@nara.gov](mailto:ford.museum@nara.gov). Gerald R. Ford Library is located at 1000 Beal Avenue, Ann Arbor, MI 48109-2114. The phone number is 734-741-2218 and the fax number is 734-741-2341. The e-mail address is [ford.library@nara.gov](mailto:ford.library@nara.gov).

(h) Jimmy Carter Library is located at 441 Freedom Parkway, Atlanta, GA 30307-1498. The phone number is 404-331-3942 and the fax number is 404-730-2215. The e-mail address is [carter.library@nara.gov](mailto:carter.library@nara.gov).

(i) Ronald Reagan Library is located at 40 Presidential Dr., Simi Valley, CA 93065-0699. The phone number is 800-410-8354 or 805-522-8444 and the fax number is 805-522-9621. The e-mail address is [reagan.library@nara.gov](mailto:reagan.library@nara.gov).

(j) George Bush Library is located at 1000 George Bush Drive West, College Station, TX 77845. The phone number is 979-691-4000 and the fax number is 979-691-4050. The email address is [bush.library@nara.gov](mailto:bush.library@nara.gov).

[65 FR 38730, June 22, 2000, as amended at 67 FR 43254, June 27, 2002; 68 FR 33405, June 4, 2003]

**§ 1253.4 Washington National Records Center.**

Washington National Records Center is located at 4205 Suitland Road, Suitland, MD (mailing address: Washington National Records Center, 4205 Suitland Road, Suitland, MD, 20746-8001). The hours are 8 a.m. to 4:30 p.m., Monday through Friday, except Federal holidays. The phone number is 301-778-1600.

[68 FR 33405, June 4, 2003]

**§ 1253.5 National Personnel Records Center.**

(a) *Military Personnel Records.* NARA—National Personnel Records Center—Military Personnel Records is located at 9700 Page Ave., St. Louis, MO 63132-5100. The hours are 7:30 a.m. to 3:45 p.m., Monday through Friday, except Federal holidays.

(b) *Civilian Personnel Records.* NARA—National Personnel Records Center—Civilian Personnel Records is located at 111 Winnebago St., St. Louis, MO 63118-4199. The hours are 7:30 a.m.

## § 1253.6

to 3:45 p.m., Monday through Friday, except Federal holidays.

[67 FR 43254, June 27, 2002]

### § 1253.6 Records Centers.

All records centers are closed on Federal holidays. Information for each center is as follows:

(a) NARA—Northeast Region (Boston) is located at the Frederick C. Murphy Federal Center, 380 Trapelo Rd., Waltham, MA 02452-6399. The hours are 8 a.m. to 4:30 p.m., Monday through Friday. The telephone number is 781-663-0139.

(b) NARA—Northeast Region (Pittsfield, MA) is located at 10 Conte Drive, Pittsfield, MA 01201-8230. The hours are 8 a.m. to 4:30 p.m., Monday through Friday. The telephone number is 413-236-3600.

(c) NARA—Mid Atlantic Region (Northeast Philadelphia) is located at 14700 Townsend Rd., Philadelphia, PA 19154-1096. The hours are 8 a.m. to 4:30 p.m., Monday through Friday. The telephone number is 215-305-2003.

(d) NARA—Southeast Region (Atlanta) is located at 1557 St. Joseph Ave., East Point, GA 30344-2593. The hours are 7 a.m. to 4 p.m., Monday through Friday. The telephone number is 404-763-7063.

(e) NARA—Great Lakes Region (Dayton) is located at 3150 Springboro Rd., Dayton, OH 45439-1883. The hours are 7 a.m. to 4:30 p.m., Monday through Friday. The telephone number is 937-225-2852.

(f) NARA—Great Lakes Region (Chicago) is located at 7358 S. Pulaski Rd., Chicago, IL 60629-5898. The hours are 8 a.m. to 4:30 p.m., Monday through Friday. The telephone number is 773-581-7816.

(g) NARA—Central Plains Region (Kansas City) is located at 2312 E. Bannister Rd., Kansas City, MO 64131-3011. The hours are 8 a.m. to 4 p.m., Monday through Friday. The telephone number is 816-926-6920.

(h) NARA—Central Plains Region (Lee's Summit, MO) is located at 200 Space Center Drive, Lee's Summit, MO 64064-1182. The hours are 8 a.m. to 4 p.m., Monday through Friday. The telephone number is 816-823-6272.

(i) NARA—Southwest Region (Fort Worth) is located at 501 West Felix St.,

## 36 CFR Ch. XII (7-1-03 Edition)

Bldg. 1, Fort Worth, TX (mailing address: P.O. Box 6216, Fort Worth, TX 76115-0216). The hours are 8 a.m. to 2:00 p.m., Monday through Friday. The telephone number is 817-334-5515.

(j) NARA—Rocky Mountain Region (Denver) is located at Building 48, Denver Federal Center, West 6th Ave. and Kipling Street, Denver, CO (mailing address: PO Box 25307, Denver, CO 80225-0307). The hours are 7:30 a.m. to 4 p.m., Monday through Friday. The telephone number is 303-236-0804.

(k) NARA—Pacific Region (San Francisco) is located at 1000 Commodore Dr., San Bruno, CA 94066-2350. The hours are 7:30 a.m. to 4 p.m., Monday through Friday. The telephone number is 650-876-9001.

(l) NARA—Pacific Region (Laguna Niguel, CA) is located at 24000 Avila Rd., 1st Floor East Entrance, Laguna Niguel, CA (mailing address: PO Box 6719, Laguna Niguel, CA 92607-6719). The hours are 8 a.m. to 4:30 p.m., Monday through Friday. The telephone number is 949-360-2626.

(m) NARA—Pacific Alaska Region (Seattle) is located at 6125 Sand Point Way NE, Seattle, WA 98115-7999. The hours are 7:45 a.m. to 4:15 p.m., Monday through Friday. The telephone number is 206-526-6501.

[65 FR 38730, June 22, 2000, as amended at 67 FR 43255, June 27, 2002; 68 FR 33405, June 4, 2003]

### § 1253.7 Regional Archives.

Most regional archives offer extended research room hours for microfilm research only. Information on extended hours is available from individual facilities. Regional archives are closed on Federal holidays. Information on each regional archives facility is as follows:

(a) NARA—Northeast Region (Boston) is located in the Frederick C. Murphy Federal Center, 380 Trapelo Rd., 8 a.m. to 4:30 p.m., Monday through Friday. The telephone number is 781-663-0121.

(b) NARA—Northeast Region (Pittsfield, MA) is located at 10 Conte Drive, Pittsfield, MA 01201-8230. The hours are 8 a.m. to 4:30 p.m., Monday through Friday. The telephone number is 413-236-3600.



(c) NARA—Northeast Region (New York City) is located at 201 Varick St., New York, NY 10014-4811. The hours are 8 a.m. to 4:30 p.m., Monday through Friday. The telephone number is 212-401-1620.

(d) NARA—Mid Atlantic Region (Center City Philadelphia) is located at 900 Market St., Philadelphia, PA 19107-4292. The hours are 8 a.m. to 5 p.m., Monday through Friday. The telephone number is 215-597-0921.

(e) NARA—Southeast Region (Atlanta) is located at 1557 St. Joseph Ave., East Point, GA 30344-2593. The hours are 7 a.m. to 4 p.m., Monday through Friday. The telephone number is 404-763-7474.

(f) NARA—Great Lakes Region (Chicago) is located at 7358 S. Pulaski Rd., Chicago, IL 60629-5898. The hours are 8 a.m. to 4:15 p.m., Monday through Friday. The telephone number is 773-581-7816.

(g) NARA—Central Plains Region (Kansas City) is located at 2312 E. Bannister Rd., Kansas City, MO 64131-3060. The hours are 7:30 a.m. to 4 p.m., Monday through Friday. The telephone number is 816-926-6920.

(h) NARA—Southwest Region (Fort Worth) is located at 501 West Felix St., Bldg. 1, Dock 1, Fort Worth, TX (mailing address: P.O. Box 6216, Fort Worth, TX, 76115-0216). The hours are 6:30 a.m. to 4 p.m., Monday through Friday. The telephone number is 817-334-5525.

(i) NARA—Rocky Mountain Region (Denver) Textual Research room is located at Building 48, Denver Federal Center, West 6th Ave. and Kipling Street, Denver, CO. The Microfilm Research room is located at Building 46, Denver Federal Center, West 6th Ave. and Kipling Street, Denver, CO. (The mailing address: PO Box 25307, Denver, CO 80225-0307). The hours are 7:30 a.m. to 3:45 p.m., Monday through Friday. The telephone number is 303-236-0817.

(j) NARA—Pacific Region (Laguna Niguel, CA) is located at 24000 Avila Rd., 1st Floor East Entrance, Laguna Niguel, CA (mailing address: PO Box 6719, Laguna Niguel, CA 92607-6719). The hours are 8 a.m. to 4:30 p.m., Monday through Friday. The telephone number is 949-360-2641.

(k) NARA—Pacific Region (San Francisco) is located at 1000 Commodore

Dr., San Bruno, CA 94066-2350. The hours are 7:30 a.m. to 4 p.m., Monday through Friday. The telephone number is 650-876-9009.

(l) NARA—Pacific Alaska Region (Seattle) is located at 6125 Sand Point Way NE, Seattle, WA 98115-7999. The hours are 7:45 a.m. to 4:15 p.m., Monday through Friday. The telephone number is 206-526-6501.

(m) NARA—Pacific Alaska Region (Anchorage) is located at 654 West Third Avenue, Anchorage, AK 99501-2145. The hours are 8 a.m. to 4 p.m., Monday through Friday. The telephone number is 907-271-2443.

[65 FR 38730, June 22, 2000, as amended at 67 FR 43255, June 27, 2002; 68 FR 33405, June 4, 2003]

#### § 1253.8 Are NARA research room facilities closed on Federal holidays?

(a) NARA research room facilities are closed on all Federal holidays.

(b) When a Federal holiday is on a Saturday but the official observance is on the preceding Friday, the research rooms that are normally open on Saturday will be closed on the Saturday as well as the Friday.

[67 FR 43255, June 27, 2002]

## PART 1254—AVAILABILITY OF RECORDS AND DONATED HISTORICAL MATERIALS

### Subpart A—General

#### Sec.

1254.1 General provisions.

1254.2 Location of documents and hours of use.

1254.4 Research procedures.

1254.6 Researcher identification card.

1254.8 Subpoenas and other legal demands for records transferred to the National Archives and Records Administration.

### Subpart B—Research Room Rules

1254.10 Registration.

1254.12 Researcher's responsibility for documents.

1254.14 Restrictions on using microfilm readers.

1254.16 Prevention of damage to documents.

1254.17 Keeping documents in order.

1254.18 Removal or mutilation of documents.

1254.20 Conduct.

1254.24 Locker use policy.

## § 1254.1

- 1254.25 Rules for public access use of the Internet on NARA-supplied personal computers.
- 1254.26 Additional rules for use of certain research rooms in NARA facilities in the Washington, DC, area.
- 1254.27 Additional rules for use of certain research rooms in regional records services facilities and Presidential libraries.

### Subpart C—Access to Unclassified Records and Donated Historical Materials

- 1254.30 Archives.
- 1254.32 FRC records.
- 1254.34 Records of defunct agencies.
- 1254.35 Presidential records and Nixon Presidential materials.
- 1254.36 Donated historical materials.

### Subpart D—Access to National Security Information

- 1254.40 Access to national security information.
- 1254.44 Freedom of Information Act (FOIA) requests.
- 1254.46 Public requests for mandatory review of classified information under Executive Order 12356.
- 1254.48 Access by historical researchers and former Presidential appointees.
- 1254.50 Fees.

### Subpart E—Information, Reproduction, and Authentication Services

- 1254.70 NARA copying services.
- 1254.71 Researcher use of the self-service card-operated copiers in the National Archives Building and the National Archives at College Park.
- 1254.72 Information about documents.
- 1254.74 Information from documents.
- 1254.76 Certification of copies.

### Subpart F—Microfilming Archival Records

- 1254.90 General.
- 1254.92 Requests to microfilm records and donated historical materials.
- 1254.94 Criteria for granting the requests.
- 1254.96 Microfilm preparation.
- 1254.98 Equipment standards.
- 1254.100 Microfilming procedures.
- 1254.102 Rescinding permission.

AUTHORITY: 44 U.S.C. 2101–2118; 5 U.S.C. 552; and E.O. 12600, 52 FR 23781, 3 CFR, 1987 Comp., p. 235.

EDITORIAL NOTE: Nomenclature changes to part 1254 appear at 59 FR 29192, June 6, 1994.

## 36 CFR Ch. XII (7–1–03 Edition)

### Subpart A—General

#### § 1254.1 General provisions.

(a) Researchers will normally use documents in designated research rooms only.

(b) Original documents will not normally be made available when microfilm copies or other alternative copies of the documents are available.

(c) Persons seeking information that is published and readily available will normally be referred to a public library.

(d) A Regional Administrator, a director of a Presidential Library, or a director of a Washington, DC, area research unit may require that researchers under the age of 14 years be accompanied by an adult researcher who agrees in writing to be present when the documents are used and to be responsible for compliance with the research room rules set forth in Subpart B.

(e) Requests received in the normal course of reference service that do not specifically cite the Freedom of Information Act (5 U.S.C. 552) are not considered requests made under the act. Requests under the act must follow the procedure set forth in subpart C or subpart D of this part.

(f) Certain documents in the custody of NARA are available for exhibit, but are loaned only if the exhibitor meets exacting requirements regarding security, insurance coverage and humidity and temperature control of the exhibit area. These requirements may be obtained by writing to National Archives (NE), Washington, DC 20408.

[33 FR 4885, Mar. 22, 1968, as amended at 40 FR 7924, Feb. 24, 1975; 40 FR 28610, July 8, 1975; 42 FR 13022, Mar. 8, 1977. Redesignated and amended at 50 FR 15723, 15726, Apr. 19, 1985; 59 FR 29192, June 6, 1994; 64 FR 19901, Apr. 23, 1999]

#### § 1254.2 Location of documents and hours of use.

(a) Researchers should identify the location of the documents needed. Information about the location of records may be obtained by writing to the National Archives and Records Administration (NWCC1), Washington, DC 20408; by sending an e-mail message to [http://www.archives.gov/global\\_pages/](http://www.archives.gov/global_pages/)

*inquire\_form.html*; sending a fax request to (301) 837-0483; or calling (202) 501-5400 or (301) 837-2000.

(b) The locations and hours of operation (expressed in local time) of the depositories administered by the National Archives and Records Administration are shown in part 1253 of this chapter.

(c) Except for Federal holidays and other times specified by the Archivist or other authorized NARA officials, documents will be made available according to the schedule set forth in part 1253.

(d) In addition to the times specified in part 1253, documents may be made available at such other times as are authorized by a director.

[40 FR 7925, Feb. 24, 1975, as amended at 42 FR 13022, Mar. 8, 1977; 49 FR 33253, Aug. 22, 1984. Redesignated at 50 FR 15723, Apr. 19, 1985, and amended at 56 FR 2135, Jan. 22, 1991; 59 FR 29192, June 6, 1994; 64 FR 19901, Apr. 23, 1999; 67 FR 43254, June 27, 2002]

#### § 1254.4 Research procedures.

(a) Before applying to use documents, the researcher should ask the depository holding them whether the documents are available, whether there are enough documents to warrant a visit, or whether copies would be more practical.

(b) Researchers must apply in person at the depository that has custody of the documents.

(c) Researchers who wish to use documents not on microfilm in a depository where the microfilm research room is separate from textual research rooms, must complete a researcher identification application form and provide the information needed to decide which documents can be made available. Researchers who wish to use only microfilm documents in a depository where the microfilm research room is not separate from textual research rooms must also comply with this paragraph. Applicants must show identification containing a picture or physical description of the applicant, e.g., a driver's license or school identification card. Exceptions to this requirement must be approved by the director. If applying for access to large quantities of documents or to documents that are especially fragile or valuable, the re-

searcher may be required to furnish additional information about personal or professional qualifications or to furnish additional reasons why access is required. The collection of information contained in this paragraph has been approved by the Office of Management and Budget with the control number 3095-0016.

(d) A researcher will not be issued a researcher identification card if the branch chief or director of the relevant repository determines that:

(1) The documents which the researcher wishes to use are not in the legal custody of NARA; or

(2) The researcher is not interested in documents maintained by NARA but in information contained in secondary sources available at other institutions.

(e) Researchers using only microfilm, where the microfilm research room is separate from textual research rooms, are not issued an identification card but must register as described in § 1254.10.

(f) In addition to the procedures in this section, researchers desiring to use archives that contain national security classified information must follow procedures in subpart D.

(g) The legal custody and control over access to records that are in the physical custody of the records centers, but not yet accessioned into the National Archives of the United States, remains with the agency. NARA informs researchers of the procedures required to obtain access.

[49 FR 33253, Aug. 22, 1984. Redesignated at 50 FR 15723, Apr. 19, 1985, and amended at 56 FR 2135, Jan. 22, 1991; 59 FR 29192, June 6, 1994]

#### § 1254.6 Researcher identification card.

(a) An identification card is issued to each person whose application is approved to use records other than microfilm. Cards are valid for 1 year and may be renewed upon application. Cards issued at one NARA facility are valid at each facility, except as described in paragraph (b) of this section. They are not transferable and must be presented if requested by a guard or research room attendant.

(b) At the National Archives in College Park and other NARA facilities that issue and use plastic researcher

## § 1254.8

identification cards as part of their security systems, paper researcher identification cards issued at other NARA facilities are not valid. In facilities that use plastic researcher identification cards, NARA will issue a plastic card to replace the paper card at no charge.

[67 FR 8200, Feb. 22, 2002; 67 FR 17286, Apr. 10, 2002, as amended at 67 FR 63268, Oct. 11, 2002]

### § 1254.8 Subpoenas and other legal demands for records transferred to the National Archives and Records Administration.

(a) Access to records transferred to a Federal records center is controlled by the instructions and restrictions imposed on NARA by the Federal agency that transferred the records to the Federal records center. NARA will honor a subpoena duces tecum or other legal demand for the production of these records, to the extent required by law, if the transferring agency has imposed no restrictions. When the transferring agency has imposed restrictions, NARA will notify the authority issuing the subpoena or other legal demand that NARA must abide by the agency-imposed restrictions and will request the authority to pursue the matter directly with the transferring agency.

(b) The Archivist of the United States, the General Counsel (NGC) or his/her designee, and the Director of the Federal Records Center in which the records are stored are the only NARA officials authorized to accept a subpoena or other legal demand for records transferred to a Federal records center.

(c) A subpoena duces tecum or other legal demand for the production of documents designated as *archives* or *donated historical materials* administered by NARA may be served only on the Archivist of the United States, the General Counsel (NGC) or his/her designee, the appropriate Assistant Archivist, Director of a Regional Archives, or Director of a Presidential Library.

[50 FR 15727, Apr. 19, 1985, as amended at 59 FR 29192, June 6, 1994; 64 FR 19901, Apr. 23, 1999]

## 36 CFR Ch. XII (7-1-03 Edition)

### Subpart B—Research Room Rules

#### § 1254.10 Registration.

Researchers must register each day they enter a research facility, furnishing the information on the registration sheet or scanning a bar-coded researcher identification card, and may be asked to provide additional personal identification.

[64 FR 19901, Apr. 23, 1999]

#### § 1254.12 Researcher's responsibility for documents.

(a) The research room attendant may limit the quantity of documents delivered to a researcher at one time. The researcher must sign for the documents received and may be required to show his/her researcher identification card. The researcher is responsible for the proper handling of and prevention of damage to all documents delivered to him/her until he/she returns them. When the researcher is finished using the documents, the documents must be returned to the research room attendant. The reference service slip that accompanies the documents to the research room must not be removed. If asked to do so, the researcher must return documents as much as 15 minutes before closing time. Before leaving a research room, even for a short time, a researcher must notify the research room attendant and place all documents in their proper containers.

(b) When microfilm is available on a self-service basis, research room attendants will assist researchers in identifying research sources on microfilm and provide information concerning how to locate and retrieve the roll(s) of film containing the information of interest. The researcher is responsible for retrieving and examining the roll(s). Unless a researcher requires assistance in learning how to operate microfilm reading equipment, the researcher is expected to install the microfilm on the reader. Unless otherwise permitted, a researcher is limited to one roll of microfilm at a time. After using each roll, the researcher is responsible for refiling the roll of microfilm in the location from which it was removed, unless instructed otherwise.

(c) Researchers are responsible for complying with provisions of the Copyright Act (Title 17, United States Code) which governs the making and use of electrostatic copies or other reproductions of copyrighted materials.

[59 FR 29192, June 6, 1994, as amended at 64 FR 19901, Apr. 23, 1999]

**§ 1254.14 Restrictions on using microfilm readers.**

(a) Use of the microfilm readers in the National Archives Building will be on a first-come, first-served basis. When other researchers are waiting to use a microfilm reader, a 3-hour limit may be placed on using a reader. After 3 hours of machine use, the researcher may sign the waiting list for an additional 3-hour period.

(b) The number of researchers in the microfilm research room in the National Archives Building may be limited, for fire safety reasons, to those researchers assigned a microfilm reader.

(c) Directors of regional archives may permit reservations for use of microfilm readers and set time limits on use to meet local circumstances. Rules for use will be posted in the research room.

[59 FR 29193, June 6, 1994, as amended at 64 FR 19901, Apr. 23, 1999]

**§ 1254.16 Prevention of damage to documents.**

(a) Researchers must exercise all possible care to prevent damage to documents.

(b) Documents may not be used at a desk where there is food or liquid or where an ink pen is being used. Only pencils may be used in research rooms where original documents are used.

(c) Documents must not be leaned on, written on, folded anew, traced, or handled in any way likely to cause damage.

(d) Documents must be identified for reproduction only with a paper tab provided by NARA. Documents may not be identified with paper clips, rubber bands, self-stick notes or similar devices.

(e) Microfilm must be carefully removed from and returned, rewound, to the proper microfilm boxes. Care must be taken loading and unloading micro-

film from microfilm readers. Damaged microfilm must be reported to the research room attendant as soon as it is discovered.

(f) Exceptionally valuable or fragile documents may be used only under the conditions specified by the research room attendant.

[59 FR 29193, June 6, 1994, as amended at 64 FR 19901, Apr. 23, 1999]

**§ 1254.17 Keeping documents in order.**

A researcher must keep unbound documents in the order in which they are delivered to him/her. Documents that appear to be in disorder must not be rearranged by the researcher, but must be referred to the research room attendant. Researchers may use only one folder at a time. Researchers are not allowed to remove documents from more than one container at a time. Researchers should bring to the attention of the research room attendant microfilm put in the wrong box or file cabinet.

[Redesignated and revised at 59 FR 29193, June 6, 1994]

**§ 1254.18 Removal or mutilation of documents.**

Researchers may not remove documents from a research room. Removing or mutilating documents is forbidden by law and is punishable by fine or imprisonment or both (18 U.S.C. 2071). Researchers must check personal belongings, including briefcases, folders, coats, newspapers, or containers of any kind before entering a research room. Upon leaving, researchers must present for examination any article that could contain documents. To ensure that documents are not unlawfully removed or mutilated, the director may issue and post at the entrance to the research room instructions supplementing the rules in subpart B.

[49 FR 33254, Aug. 22, 1984. Redesignated at 50 FR 15723, Apr. 19, 1985]

**§ 1254.20 Conduct.**

(a) *Regulations.* Researchers are subject to the provisions of part 1280 of this chapter and to all rules and regulations issued and posted or distributed by a facility director supplementing Subpart B of this part, including rules

on the use of NARA equipment. Eating, drinking, chewing gum, or using smokeless tobacco products in a research room are prohibited. Smoking is prohibited in all NARA facilities. Loud talking and other activities likely to disturb other researchers are also prohibited. Persons desiring to use typewriters, computers, sound recording devices, or similar equipment must work in areas designated by the research room attendant, when so required.

(b) *Revocation of research privileges.* Researchers who refuse to comply with the rules and regulations of a NARA facility, or by their actions or language demonstrate that they present a danger to documents or NARA property, or present a danger to or verbally or physically harass or annoy other researchers, NARA or contractor employees, or volunteers may have their research privileges revoked by NARA for up to 180 days. The revocation of research privileges means that a researcher loses research privileges at all NARA research rooms nationwide and, if the researcher holds a valid researcher identification card, the loss of the card. All NARA facilities will be notified of the revocation of research privileges. A researcher whose research privileges have been revoked will be sent a written notice of the reasons for the revocation within 3 work days of the action.

(c) *Reinstatement of research privileges.* The researcher has 30 calendar days after the date of revocation to appeal the action in writing and seek reinstatement of research privileges. Appeals should be mailed to the Archivist of the United States (address: National Archives and Records Administration (N), 8601 Adelphi Road, College Park, MD 20740-6001). The Archivist has 30 calendar days from receipt of an appeal to decide whether to reinstate research privileges. The response will be made in writing and sent to the researcher whose research privileges have been revoked. If the revocation of privileges is upheld or if no appeal is made, the researcher may request reinstatement of research privileges no earlier than 180 calendar days from the date the privileges were revoked. This request may include application for a new researcher identification card. The rein-

statement of research privileges applies to all research rooms, except that in the case of a new researcher identification card, the researcher will be issued a card for a probationary period of 60 days. At the end of the probationary period, the researcher may apply for a new, unrestricted identification card, which will be issued if the researcher's conduct during the probationary period has been in accordance with the rules of conduct set forth in this part and in 36 CFR part 1280.

(d) *Extending the revocation period.* If the reinstatement of research privileges would pose a threat to the safety of persons, property, or NARA holdings, or if, in the case of a probationary identification card, the researcher has failed to comply with the rules of conduct for NARA facilities, NARA may extend the revocation of privileges for 180-day periods. Researchers will be sent a written notice all such extensions within 3 work days of NARA's decision to continue the revocation of research privileges. The researcher has 30 calendar days after the decision to extend the revocation of research privileges to appeal the action in writing. Appeals should be mailed to the Archivist at the address given above. The Archivist has 30 calendar days from receipt of an appeal to decide whether to reinstate research privileges. The response will be made in writing and sent to the researcher.

[64 FR 19901, Apr. 23, 1999]

**§ 1254.24 Locker use policy.**

(a) The National Archives and Records Administration (NARA) prohibits researchers from carrying boxes, briefcases, satchels, valises, purses, or other large containers into the research rooms or authorized stack areas. To accommodate researchers who have these items, lockers or other storage facilities are conveniently located near research rooms. These lockers or other storage facilities are available on a first-come-first-served basis.

(b) Researchers' personal belongings must be removed each night from the lockers or other storage facilities provided to hold them unless special permission is obtained in advance from designated research room staff. If personal belongings are not removed from

the facilities by the researcher, they will be removed by NARA personnel. Directions for reclaiming confiscated items will be posted near the lockers or other storage facilities.

(c) The National Archives and Records Administration is not responsible for the loss or theft of articles stored in the lockers.

(d) NARA may charge a replacement fee for lost locker keys.

[45 FR 8603, Feb. 8, 1980. Redesignated at 50 FR 15723, Apr. 19, 1985, as amended at 64 FR 19902, Apr. 23, 1999]

**§ 1254.25 Rules for public access use of the Internet on NARA-supplied personal computers.**

(a) Public access personal computers (workstations) are available for Internet use in all NARA research rooms. The number of workstations varies per location. These workstations are intended for research purposes and are provided on a first-come-first-served basis. When others are waiting to use the workstation, a 30-minute time limit may be imposed on the use of the equipment.

(b) Researchers should not expect privacy while using these workstations. These workstations are operated and maintained on a United States Government system, and activity may be monitored to protect the system from unauthorized use. By using this system, researchers expressly consent to such monitoring and the reporting of unauthorized use to the proper authorities.

(c) At least one Internet access workstation will be provided in each facility that complies with the Workforce Investment Act of 1998, ensuring comparable accessibility to individuals with disabilities.

(d) Researchers may download information to a diskette and print materials, but the research room staff will furnish the diskettes and paper. Researchers may not use personally owned diskettes on NARA personal computers.

(e) Researchers may not load files or any type of software on these workstations.

[67 FR 8200, Feb. 22, 2002]

**§ 1254.26 Additional rules for use of certain research rooms in NARA facilities in the Washington, DC, area.**

(a) Admission to research rooms in the National Archives Building and the National Archives at College Park facility is limited to individuals examining and/or copying documents and other materials in the custody of the National Archives and Records Administration. Children under the age of 14 will not be admitted to these research rooms unless they have been granted research privileges or are granted an exception to this provision to view specific documents that a parent or other accompanying adult researcher is using. The exception will be granted by the Chief of the Archives I or Archives II Research Room Services Branch for a child who is able to read and who will be closely supervised by the adult researcher while in the research room. Normally, such a child will be admitted only for the short period required to view the documents. Unless otherwise permitted, persons without a researcher card may not actively participate in research activities, e.g., removing, copying, or refiling documents. Students under the age of 14 who wish to perform research on original documents must apply in person to the Chief of the Research Room Services Branch where the documents are located and present a letter of reference from a teacher. Such students may contact NARA by phone or letter in advance of their visit to discuss their eligibility for research privileges. Students under the age of 14 who have been granted research privileges will be required to be accompanied in the research room by an adult with similar privileges, unless the Chief of the Archives I or Archives II Research Room Services Branch specifically waives this requirement with respect to individual researchers.

(b) The procedures in paragraphs (d) through (g) of this section apply to all research rooms in the National Archives Building (except the Microfilm Research Room) and in the National Archives at College Park facility. These procedures are in addition to the procedures specified elsewhere in this part.

(c) Researchers bringing personal computers, tape recorders, cameras, and other equipment into the National Archives Building must complete the Equipment Log at the guard's desk. The log will evidence personal ownership and will be checked by the guard when such equipment is removed from the building.

(d) Researchers must present a valid researcher identification card to the guard or research room attendant on entering the research room. All researchers are required to register their attendance each day. Researchers will also register the time they leave the research area at the end of the visit for that day. Researchers are not required to sign in or out when leaving the area temporarily.

(e) Researchers may not bring into the research rooms overcoats, raincoats, hats, or similar apparel; personal paper-to-paper copiers, unless permitted in accordance with § 1254.71(e) of this part; briefcases, suitcases, day packs, purses, or similar containers of personal property; notebooks, notepaper, note cards, folders or other containers for paper. These items may be stored at no cost in lockers available for researchers. The following exceptions may be granted:

(1) Hand-held wallets and coin purses for the carrying of currency, coins, credit cards, keys, drivers licenses and other identification cards may be brought into research rooms, but are subject to inspection when the researcher enters or leaves the room. The guard or research room attendant shall judge whether the wallet or purse may be considered small for purposes of this section;

(2) Notes, references, lists of documents to be consulted, and other materials may be admitted if the chief of the branch administering the research room or the senior staff member on duty in the research room determines they are essential to a researcher's work requirements. Materials approved for admission will be stamped, initialed, and dated by a NARA or contractor employee, to indicate that they are the personal property of the researcher;

(3) Personal computers, tape recorders, scanners, cameras, and similar

equipment may be admitted by the research room attendant provided such equipment meet the approved standards for preservation set by the NARA Preservation Programs unit. Use of researcher owned equipment may be limited to designated areas within the research rooms. If demand to use equipment exceeds the space available for equipment use, time limits may be imposed. Equipment that could potentially damage documents will not be approved. Scanners and other copying equipment must meet these minimum standards:

(i) Equipment platens or copy boards must be the same size or larger than the records. No part of a record may overhang the platen or copy board.

(ii) No part of the equipment may come in contact with records in a manner that causes friction, abrasion, or that otherwise crushes or damages records.

(iii) Drum scanners are prohibited.

(iv) Automatic feeder devices on flat-bed scanners are prohibited. When using a slide scanner, slides must be checked after scanning to ensure that no damage occurs while the slide is inside the scanner.

(v) Light sources must not raise the surface temperature of the record being copied. Light sources that generate ultraviolet light must be filtered.

(vi) All equipment surfaces must be clean and dry before being used with records. Cleaning and equipment maintenance activities, such as replacing toner cartridges, may not take place when records are present. Aerosols or ammonia-containing cleaning solutions are not permitted. A 50% water and 50% isopropyl alcohol solution is permitted for cleaning.

The chief of the branch administering the research room or the senior staff member on duty in the research room will review the determination made by the research room attendant if requested to do so by the researcher; and

(4) Notepaper and notecards provided by the National Archives and electrostatic copies made on copying machines in NARA research rooms which are marked with the statement "Reproduced at the National Archives" may be brought back into the research room on subsequent visits but must be



presented on entry to the research room attendant for inspection.

(f) NARA will furnish to researchers, without charge, pencils and specially marked lined and unlined notepaper and notecards, for use in the research rooms. Pencils and unused notepaper and notecards should be returned to the research room attendant at the end of the day.

(g) The personal property of all researchers, including notes, electrostatic copies, equipment cases, tape recorders, cameras, personal computers, and other property, will be inspected before removal from the research room. Guards and research room attendants may request that a member of the research room staff examine such personal items prior to their removal from the research room.

(h) In addition to the procedures in paragraphs (c) through (g) of this section, the following procedures apply to the Motion Picture, Sound, and Video Research Room (hereinafter, the "research room") in the College Park facility:

(1) Use of NARA viewing and listening equipment in the research room is provided on a first-come-first-served basis. When others are waiting to use the equipment, a three-hour limit may be imposed on the use of the equipment.

(2) The following procedures shall be followed when personal recording equipment and accessories are brought into the unrestricted viewing and copying area in the research room:

(i) Personal recording equipment brought into the unrestricted viewing and copying area in the research room may be inspected and tagged by the research room attendant prior to admittance. All equipment and accessory devices must be placed on the carts provided by NARA, except that a tripod holding a video camera may be placed on the floor in front of a film-viewing station. NARA is not responsible for damage to or loss of personal equipment and accessories.

(ii) Researchers shall remain in the research room while their personal equipment is in use at an audio or video viewing station. The film viewing stations must be attended at all times while in use. Researchers shall remove

their personal equipment from the research room when they leave the room for the day.

(iii) NARA will not be responsible for assisting with "hook-up" to NARA viewing equipment; for providing compatibility between the personal recording equipment and NARA viewing equipment; or for the quality of the copies made by researchers. NARA will provide the researcher information on the types of NARA equipment being used in the research room and on the cables necessary for hook up to the NARA viewing equipment.

(3) When a researcher brings audio or video recording tapes or cassettes into the unrestricted area of the research room, the research room attendant will mark the recording media "NARA-approved personal property" for identification purposes. Such media shall be inspected upon exit from the research room, as well as upon exit from the National Archives Building.

(4) A NARA-furnished video copying station and 120-minute blank video cassette may be reserved, for a fee, on a first-come, first-served basis for a 90-minute period of time. If no other individual is waiting to use the station, an additional time period may be reserved at the end of the current period. Personal recording devices may not be connected to NARA equipment at the video copying station. Only NARA-provided tapes may be used at the video copying station. Fees for use of the station and blank cassette are specified in § 1258.12 of this chapter.

(5) The NARA-furnished recorder or personal recording device and media may be used to make a copy of unrestricted archival materials in the research room.

(6) Each researcher will be provided a copy of the Motion Picture, Sound, and Video Research Room rules and a warning notice on potential copyright claims in unrestricted titles. The individual making and/or using the copy is responsible for obtaining any needed permission or release from a copyright owner for other than personal use of the copy.

**§ 1254.27**

(7) No personal recording device or media is permitted in the restricted viewing area in the research room.

[51 FR 17187, May 9, 1986, as amended at 56 FR 2135, Jan. 22, 1991; 56 FR 58312, Nov. 19, 1991; 57 FR 46306, Oct. 8, 1992; 59 FR 29193, June 6, 1994; 64 FR 19903, Apr. 23, 1999]

**§ 1254.27 Additional rules for use of certain research rooms in regional records services facilities and Presidential libraries.**

(a) When directed by the appropriate regional administrator or library director, the following procedures shall be observed in regional records services facility and Presidential library archival research rooms where original documents are used. These procedures are in addition to the procedures specified elsewhere in this part.

(b) Researchers must present a valid researcher identification card to the guard or research room attendant on entering the room. All researchers are required to sign each day the research room registration sheet at the entrance to the research room. Where instructed to do so, researchers also sign out when leaving the research room for the day. Researchers are not required to sign in or out when leaving the area temporarily or at the end of the day.

(c) Researchers may not bring into the research room overcoats, raincoats, hats, and similar apparel, and briefcases, suitcases, daypacks, purses, or similar containers of personal property. In facilities where NARA provides notepaper and notecards, researchers also may not bring into the research room notebooks, notepaper, notecards, folders or other containers for papers. In facilities where NARA provides a self-service copier, researchers may not bring into the research room personal copying equipment including personal paper-to-paper copiers. These items may be stored at no cost in lockers or other storage facilities in the NARA facility. The following exceptions may be granted:

(1) Hand-held wallets and coin purses for carrying currency, coins, credit cards, keys, drivers licenses and other identification cards may be brought into research rooms, but are subject to inspection when the researcher enters or leaves the room. The guard or re-

**36 CFR Ch. XII (7-1-03 Edition)**

search room attendant shall judge whether the wallet or purse may be considered small for purposes of this section;

(2) Notes, references, lists of documents to be consulted, and other materials may be admitted if the director, or the senior attendant on duty in the research room determines they are essential to a researcher's work requirements. Materials will be presented to the attendant when the researcher enters the research room. If the materials are approved for admission, they may be stamped to indicate that they are the researcher's property;

(3) Typewriters, personal computers, tape recorders, and hand-held cameras may be admitted by the guard or research room attendant provided that they are inspected, approved, and tagged prior to admittance. For a regional records services facility, the regional administrator, the director or other supervisor having responsibility for research room operations in a facility, or the senior attendant on duty will review the determination made by the guard or research room attendant if requested to do so by the researcher. In a Presidential library, the director, or the senior attendant on duty in the research room will review the determination made by the guard or research room attendant if requested to do so by the researcher. In facilities where personal paper-to-paper copiers and scanners are permitted, the researcher must obtain prior written approval from the facility director to bring in the copier or scanner. The request to bring a personal copier or scanner should state the space and power consumption requirements and the intended period of use; and

(4) Notepaper and notecards provided by the National Archives and electrostatic copies made on copying machines in NARA research rooms which are marked with the statement "Reproduced at the National Archives" may be brought back into the research room on subsequent visits but must be presented on entry to the guard or research room attendant for inspection.

(d) NARA may furnish specially marked lined and unlined notepaper and notecards, without charge, to researchers for use in the research

rooms. Unused notepaper and notecards should be returned to the research room attendant at the end of the day.

(e) The personal property of all researchers, including notes, electrostatic copies, typewriter cases, tape recorders, cameras, personal computers, and other personal property, will be inspected before removal from the research room. Guards and research room attendants may request that a member of the research room staff examine such personal items prior to their removal from the research room.

(f) Researchers may use NARA self-service copiers or authorized personal paper-to-paper copiers to copy documents in accordance with NARA document handling instructions and after review of the documents by the research room attendant to determine their suitability for copying. The director or the senior archivist on duty in the research room will review the determination of suitability if requested by the researcher. The following types of documents are not suitable for copying on a self-service or personal copier:

- (1) Bound archival volumes;
- (2) Documents fastened together by staples, clips, acco fasteners, rivets, or similar fasteners, where folding or bending the document may cause damage;
- (3) Documents larger than the glass copy plate of the copier;
- (4) Documents with uncancelled security classification markings;
- (5) Documents with legal restrictions on copying; and
- (6) Documents which, in the judgement of the research room attendant, are in poor physical condition or which may be subject to possible damage if copied.

[51 FR 31617, Sept. 4, 1986, as amended at 59 FR 29192, 29194, June 6, 1994; 64 FR 19903, Apr. 23, 1999]

### Subpart C—Access to Unclassified Records and Donated Historical Materials

#### § 1254.30 Archives.

The use of archives is subject to the restrictions prescribed by statute or Executive order or by the restrictions

specified in writing in accordance with 44 U.S.C. 2108 by the agency from which the records were transferred. NARA will make available any reasonably segregable portion of a record after the restricted portion has been deleted. The restrictions are published in the "Guide to the National Archives of the United States," and supplemented by restriction statements approved by the Archivist of the United States and set forth in part 1256 of this chapter. The Guide is available from the Superintendent of Documents, Government Printing Office, Washington, DC 20402. The Guide may also be consulted at the NARA research facilities listed in part 1253 of this chapter.

[54 FR 32069, Aug. 4, 1989]

#### § 1254.32 FRC records.

Requests for access to records on deposit in Federal records centers shall be addressed directly to the appropriate agency or to the FRC director at the address shown in part 1253. The use of FRC records is subject to access rules prescribed by the agency from which the records were transferred. When the agency's rules permit, NARA makes FRC records available to requesters. When access is precluded by these rules and restrictions, the FRC director will refer to the responsible agency the requests and any appeals for access, including those made under the Freedom of Information Act.

[40 FR 7925, Feb. 24, 1975. Redesignated at 50 FR 15723, Apr. 19, 1985]

#### § 1254.34 Records of defunct agencies.

Access to archives and FRC records received from agencies which have ceased to exist without a successor in function are handled in accordance with §§ 1254.30 and 1254.50.

[44 FR 18496, Mar. 28, 1979. Redesignated at 50 FR 15723, Apr. 19, 1985]

#### § 1254.35 Presidential records and Nixon Presidential materials.

Access to Presidential records transferred to NARA is governed by 36 CFR part 1270. Access to the Nixon Presidential materials is governed by 36 CFR part 1275.

[59 FR 29194, June 6, 1994]

**§ 1254.36 Donated historical materials.**

The public use of donated historical materials is subject to restrictions on their use and availability as stated in writing by the donors or depositors of such materials and other restrictions imposed by statute. (Researchers are encouraged to confer with the appropriate director or reference staff member on any question of copyright.) In addition, use is subject to all conditions specified by the Archivist of the United States for purposes of archival preservation.

[59 FR 29194, June 6, 1994]

### Subpart D—Access to National Security Information

**§ 1254.40 Access to national security information.**

(a) Declassification of and public access to national security information and material, hereinafter referred to as “classified information” or collectively termed “information” is governed by Executive Order 12356 of April 2, 1982 (3 CFR, 1982 Comp., p. 166), the implementing Information Security Oversight Office Directive Number 1 of June 22, 1982 (47 FR 27836, June 25, 1982) and the Freedom of Information Act (5 U.S.C. 552).

(b) Public access to documents declassified in accordance with this regulation may be restricted or denied for other reasons under the provisions of 5 U.S.C. 552(b) for accessioned agency records; 36 CFR 1254.36 for donated historical materials; 44 U.S.C. 2201 *et seq.* and 36 CFR part 1270 for Presidential records; and 44 U.S.C. 2111 note and 36 CFR part 1275 for Nixon Presidential materials.

[59 FR 29194, June 6, 1994]

**§ 1254.44 Freedom of Information Act (FOIA) requests.**

(a) *Requests for access to national security information under the Freedom of Information Act.* Requests for access to national security information under the FOIA are processed in accordance with the provisions of 36 CFR part 1250. Time limits for responses to FOIA requests for national security information are those provided in the FOIA, rather than the longer time limits pro-

vided for responses to mandatory review requests specified by Executive Order 12958, Classified National Security Information (3 CFR, 1995 Comp., p. 333).

(b) *Agency action.* Upon receipt of a request forwarded by NARA for a determination regarding declassification, the agency with declassification responsibility shall:

(1) Advise whether the information should be declassified in whole or in part or should continue to be exempt from declassification;

(2) Provide a brief statement of the reason any requested information should not be declassified; and

(3) Return all reproductions referred for determination, including a copy of each document which should be released only in part, marked to indicate the portions which remain classified.

(c) *Denials and appeals.* Denials under FOIA of access to national security information accessioned into the National Archives of the United States are made by designated officials of the originating or responsible agency or by NARA under a written delegation of authority. You must appeal determinations that records remain classified for reasons of national security to the agency with responsibility for protecting and declassifying that information. NARA will provide you with the necessary appeal information in those cases.

[49 FR 1349, Jan. 11, 1984. Redesignated at 50 FR 15723, Apr. 19, 1985; further redesignated and amended at 51 FR 22076, June 18, 1986; 54 FR 32070, Aug. 4, 1989; 66 FR 16382, Mar. 23, 2001]

**§ 1254.46 Public requests for mandatory review of classified information under Executive Order 12356.**

United States citizens or permanent resident aliens, Federal agencies, or State or local governments wishing to request mandatory review of classified information that has been accessioned into the National Archives or donated to the Government may do so by describing the document or material containing the information with sufficient specificity to enable NARA to locate it with a reasonable amount of effort. When practicable, a request shall include the name of the originator and

recipient of the information, as well as its date, subject, and file designation. If the information sought cannot be identified from the description provided or if the information sought is so voluminous that processing it would interfere with NARA's capacity to serve all requestors on an equitable basis, NARA shall notify the requestor that, unless additional information is provided or the scope of the request is narrowed, no further action will be taken. NARA shall review for declassification and release the requested information or those declassified portions of the request that constitute a coherent segment unless withholding is otherwise warranted under applicable law. Requests for mandatory review should be addressed to the appropriate NARA depository listed in part 1253.

[49 FR 1350, Jan. 11, 1984. Redesignated at 50 FR 15723, Apr. 19, 1985]

**§ 1254.48 Access by historical researchers and former Presidential appointees.**

(a) Access to classified information may be granted to U.S. citizens who are engaged in historical research projects or who previously occupied policy-making positions to which they were appointed by the President. Persons desiring permission to examine material under this special historical researcher/Presidential appointees access program should contact NARA at least 4 months before they desire access to the materials to permit time for the responsible agencies to process the requests for access. NARA will inform requestors of the agencies to which they will have to apply for permission to examine classified information, including classified information originated by the White House or classified information in the custody of the National Archives which was originated by a defunct agency.

(b) Requestors may examine records under this program only after the originating or responsible agency:

(1) Determines in writing that access is consistent with the interest of national security;

(2) Takes appropriate steps to protect classified information from unauthorized disclosure or compromise, and ensures that the information is safe-

guarded in a manner consistent with Executive Order 12356; and

(3) Limits the access granted to former presidential appointees to items that the person originated, reviewed, signed, or received while serving as a presidential appointee.

(c) To protect against the possibility of unauthorized access to restricted documents, a director may issue instructions supplementing the research room rules provided in subpart B.

[49 FR 1352, Jan. 11, 1984. Redesignated at 50 FR 15723, Apr. 19, 1985 and 51 FR 22076, June 18, 1986; 59 FR 29194, June 6, 1994]

**§ 1254.50 Fees.**

NARA will charge requestors for copies of declassified documents according to the fees listed in §1258.12 of this chapter.

[59 FR 29194, June 6, 1994]

**Subpart E—Information, Reproduction, and Authentication Services**

**§ 1254.70 NARA copying services.**

(a) The copying of documents will be done by a contractor or NARA staff with equipment belonging to NARA. NARA reserves the right to make a duplicate, at NARA expense, of any material copied. Such duplicates may be used by NARA to make additional copies for others.

(b) In order to preserve the original documents, documents which are available on microfilm or other alternate copy will not be copied by other means as long as a legible copy (electrostatic, photographic, or microfilm) can be made from the microfilm.

[52 FR 20080, May 29, 1987; 59 FR 29194, June 6, 1994, as amended at 64 FR 19903, Apr. 23, 1999]

**§ 1254.71 Researcher use of the self-service card-operated copiers in the National Archives Building and the National Archives at College Park.**

(a) *General.* Self-service card-operated copiers are located in research rooms in the National Archives Building and the National Archives at College Park. Other copiers set aside for use by reservation are located in designated research areas. Procedures for

## § 1254.71

## 36 CFR Ch. XII (7-1-03 Edition)

use are outlined in paragraphs (b) through (h) of this section.

(b) *Limitations and hours of use.* (1) There is a 3-minute time limit on copiers in research rooms when others are waiting to use the copier. Researchers using microfilm reader-printers may be limited to three copies when others are waiting to use the machine. Researchers wishing to copy large quantities of documents should see a staff member in the research room to reserve a copier for an extended time period.

(2) If an appointment must be canceled due to copier failure, NARA will make every effort to schedule a new mutually agreed-upon time. However, NARA will not displace researchers whose appointments are not affected by the copier failure.

(c) *Copying procedures.* (1) Individual documents to be copied shall be tabbed in accordance with the procedures governing the tabbing of documents and; brought to the research room attendant for inspection in the file unit. The research room attendant will examine the documents to determine whether they can be copied on the self-service copier. The chief of the branch administering the research room will review the determination of suitability if asked to do so by the researcher. After reproduction is completed, documents removed from files for copying must be returned to their original position in the file container, any fasteners removed to facilitate copying must be re-fastened, and any tabs placed on the documents to identify items to be copied must be removed.

(2) Researchers using the reserved copier must submit the containers of documents to the attendant for review prior to the appointment. The review time required is specified in each research room. Research room attendants may inspect documents after copying.

(3) Researchers may copy from only one box and one folder at a time. After copying the documents, the researcher must show the original documents and the copies to a research room attendant.

(d) *Documents not suitable for self-service copying.* The following types of documents may not be copied on the self-service copiers:

(1) Bound archival volumes (except when specialized copiers are provided);

(2) Documents fastened together by staples, clips, acco fasteners, rivets, or similar fasteners, where folding or bending documents may cause damage;

(3) Documents larger than the glass copy plate of the copier;

(4) Documents with uncanceled security classification markings;

(5) Documents with legal restrictions on copying; and

(6) Documents which, in the judgment of the research room attendant, are in poor physical condition or which may be subject to possible damage if copied.

(e) *Use of personal paper-to-paper copiers at the National Archives at College Park facility.* (1) NARA will approve a limited number of researchers to bring in and use personal paper-to-paper copying equipment in the Textual Research Room (Room 2000). Requests must be made in writing to the Chief, Archives II Research Room Services Branch (NWCCR2), National Archives and Records Administration, 8601 Adelphi Rd., College Park, MD 20740-6001. Requests must identify the records to be copied, the expected duration of the project, and the make and model of the equipment.

(2) NARA will evaluate requests using the following criteria:

(i) A minimum of 3,000 pages must be copied;

(ii) The project is expected to take at least 4 weeks, with the copier in use a minimum of 6 hours per day or 30 hours per week;

(iii) The copying equipment must meet the standards for preservation set by NARA's Preservation Programs unit (see § 1254.26(e)(3) of this part); and

(iv) Space is available for the personal copying project. NARA will allow no more than 3 personal copying projects in the research room at one time, with Federal agencies given priority over other users.

(3) Researchers must coordinate with research room management and oversee the installation and removal of copying equipment and are responsible for the cost and supervision of all service calls and repairs. Copying equipment and supplies must be removed

within two business days after the personal copying project is completed.

(4) NARA will not be responsible for any personal equipment or consumable supplies.

(5) Each operator must obtain a valid researcher identification card and be trained by NARA staff on the proper methods for handling and copying archival documents.

(6) Operators must abide by all regulations on copying stated in paragraphs (c), (d) and (f) of this section.

(7) NARA reserves the right to discontinue the privilege of using a personal copier at any time without notice. Conditions under which NARA would discontinue the privilege include: violation of one of the conditions in paragraphs (c), (d), (e), or (f) of this section; a need to provide space for a Federal agency; or a lack of NARA staff to supervise the area.

(f) *Cancellation of security classification markings.*

(1) Security classification markings (RESTRICTED, CONFIDENTIAL, SECRET, TOP SECRET, and others) on declassified records must be properly canceled before documents are copied. Only a NARA staff member can cancel security markings. Properly declassified documents will bear the declassification authority.

(2) Researchers may not remove from the research room copies of documents bearing uncanceled classification markings. Copies of documents with uncanceled markings will be confiscated.

(3) When individual documents are being copied, the research room staff will cancel the classification markings on each page and will place the declassification authority on the first page of each document. If the researcher is copying only selected pages from a document, the researcher must make a copy of the first page bearing the declassification authority and attach that page to any subsequent page(s) copied from the document. This declassification authority must be presented to the guard when copies of documents are removed from the research room and/or the building.

(4) Researchers using the reserved copiers are provided with a declassification strip which is attached to

the copier. The strip, which is reproduced on each page copied, cancels the security markings.

(g) *Purchasing debit cards for copiers.* Researchers may use cash to purchase a debit card from a vending machine during the hours that self-service copiers are in operation. Additionally, debit cards may be purchased with cash, check, money order, credit card, or funds from an active deposit account from the Cashier's Office located in room G-1 of the National Archives Building, and the researcher lobby of the College Park facility, during posted hours. The debit card will, when inserted into the copier, enable the user to make copies, for the appropriate fee, up to the value on the debit card. Researchers may add value to the debit card by using the vending machine. No refunds will be made. The fee for self-service copiers is found in §1258.12 of this chapter.

[56 FR 2136, Jan. 22, 1991; 56 FR 5731, Feb. 12, 1991, as amended at 59 FR 29194, June 6, 1994; 64 FR 19903, Apr. 23, 1999]

#### § 1254.72 Information about documents.

(a) Upon request, overall information pertaining to holdings or about specific documents will be furnished, provided that the time required to furnish the information is not excessive, and provided that the information is not restricted (see subpart C and subpart D).

(b) When so specified by a director, requests must be made on prescribed forms. Such forms will be approved by OMB as information collections and will bear the approved control number.

[59 FR 29195, June 6, 1994]

#### § 1254.74 Information from documents.

Normally, information contained in the documents will be furnished in the form of photocopies of the documents, subject to the provisions of §1254.70. NARA will certify facts and make administrative determinations on the basis of archives, or of FRC records when appropriate officials of other agencies have authorized NARA to do so. Such certifications and determinations will be authenticated by the seal of NARA, the National Archives of the

## § 1254.76

United States, or the transferring agency, as appropriate.

[59 FR 29195, June 6, 1994]

### § 1254.76 Certification of copies.

The responsible director, or any of his or her superiors, the Director of the Federal Register, and their designees are authorized to certify copies of documents as true copies.

[59 FR 29195, June 6, 1994]

## Subpart F—Microfilming Archival Records

SOURCE: 52 FR 20081, May 29, 1987, unless otherwise noted.

### § 1254.90 General.

(a) This subpart establishes rules and procedures governing the use of privately owned microfilm equipment to film accessioned archival records and donated historical materials in the legal and physical custody of the National Archives and Records Administration (NARA) by foreign and domestic government agencies, private commercial firms, academic research groups, and other entities or individuals who request exemption from obtaining copies through the regular fee schedule reproduction ordering system of NARA.

(b) Persons or organizations wishing to microfilm Federal agency records in the physical custody of the Washington National Records Center (WNRC) contact the director, WNRC, about procedures for obtaining permission from the originating agency to film those records. For information about procedures for obtaining permission from the originating agency to film records in the records center operation of one of NARA's regional records services facilities or in the physical custody of the National Personnel Records Center (NPRC), contact the Regional Administrator of the region in which the records are located, or the director, NPRC, for records in NPRC.

(c) Federal agencies needing to microfilm archival records in support of the agency's mission must contact the appropriate office as specified in § 1254.92 of this part, as soon as possible after the need is identified, for infor-

## 36 CFR Ch. XII (7-1-03 Edition)

mation concerning standards and procedures for microfilming archival records.

[64 FR 19904, Apr. 23, 1999]

### § 1254.92 Requests to microfilm records and donated historical materials.

(a) Requests to microfilm archival records or donated historical materials (except donated historical materials under the control of the Office of Presidential Libraries) in the Washington, DC area must be made in writing to the Assistant Archivist for Records Services—Washington, DC (NW), 8601 Adelphi Rd., College Park, MD 20740-6001. Requests to microfilm archival records or donated historical materials held in a NARA regional records service facility must be made in writing to the Assistant Archivist for Regional Records Services (NR), 8601 Adelphi Rd., College Park, MD 20740-6001. Requests to microfilm records or donated historical materials in a Presidential library or donated historical materials in the Washington area under the control of the Office of Presidential Libraries must be made in writing to the Assistant Archivist for Presidential Libraries (NL), 8601 Adelphi Rd., College Park, MD 20740-6001. OMB control number 3095-0017 has been assigned to the information collection contained in this section.

(b) Requests to use privately owned microfilm equipment should be submitted four months in advance of the proposed starting date of the microfilming project. Requests submitted with less advance notice will be considered and may be approved if adequate NARA space and staff are available and if all training, records preparation and other NARA requirements can be completed in a shorter time frame. Only one project to microfilm a complete body of documents, such as an entire series, a major continuous segment of a very large series which is reasonably divisible, or a limited number of separate series related by provenance or subject, may be included in a request. NARA will not accept additional requests from an individual or organization to microfilm records in a NARA facility while NARA is evaluating an earlier request from that individual or



organization to microfilm records at that facility. NARA will establish the number of camera spaces available to a single project based upon the total number of projects approved for filming at that time.

(c) The request must include:

(1) A description of the documents to be copied which includes the following elements:

(i) Agency of origin or, for donated historical materials, title of the collection,

(ii) Title of series or file segment;

(iii) Date span; and

(iv) Estimated volume in number of pages or cubic feet.

(2) The estimated amount of time (work-days) that the microfilm copying project will take; the date that the requester would like to begin the project; and the number of persons who would require training (see § 1254.100(b)).

(3) The number and a description of the equipment that will be used for copying including:

(i) The name of the manufacturer and model number; and

(ii) The type of light source to be employed (fluorescent, tungsten, or electronic flash) and if electronic flash (i.e., strobe) or fluorescent, whether the light source is filtered to omit ultraviolet radiation.

(4) A statement of the procedures which will be followed to ensure that all pages are copied, that the images on the microfilm are legible, and that the microfilm is properly processed. At a minimum, the procedures should meet the requirements specified in part 1230 of this chapter regarding the microfilming of permanent records.

(d) The requester must agree to credit the National Archives or the particular Presidential Library having custody of the original documents. The credit must appear at the beginning of a microfilm publication and in any publicity material or descriptions of the publication.

(1) If the original documents are Federal records, the requester must agree to include on the film this statement: "The documents reproduced in this publication are among the records of the (name of agency) in the custody of the National Archives of the United

States. No copyright is claimed in these official U.S. Government records."

(2) If the original documents are donated historical materials, the requester must agree to include on the film this statement: "The documents reproduced in this publication are donated historical materials from (name of donor) in the custody of the (name of Presidential library or National Archives). The National Archives administers them in accordance with the requirements of the donor's deed of gift and the U.S. Copyright Law, Title 17, U.S.C."

(3) If the original documents are presidential or vice-presidential records as specified in 44 U.S.C. 2201, the requester must agree to include on the film this statement: "The documents reproduced in this publication are presidential records in the custody of the (name of Presidential library or National Archives of the United States). NARA administers them in accordance with the requirements of Title 44, U.S.C. No copyright is claimed in these official presidential records."

(4) If the original documents are records of Congress, the requester must agree to include on the film this statement: "The documents reproduced in this publication are among the records of the (House of Representatives/Senate) in the physical custody of National Archives and Records Administration (NARA). NARA administers them in accordance with the requirements of the (House/Senate).

(e) If the person or organization producing the film plans to copyright the microfilm publication, the National Archives and Records Administration must be given a royalty-free worldwide license to sell the publication seven years after filming at the NARA facility is completed, or earlier if there is no commercial distributor.

[52 FR 20081, May 29, 1987; 52 FR 22415, June 11, 1987, as amended at 59 FR 29195, June 6, 1994; 64 FR 19904, Apr. 23, 1999]

**§ 1254.94 Criteria for granting the requests.**

(a) NARA will evaluate the requests on the basis of the extent to which completion of a proposed project would further NARA's efforts to preserve and

**§ 1254.94**

**36 CFR Ch. XII (7-1-03 Edition)**

to make available to the public the historically valuable records of the Government.

(1) In considering multiple requests to film at the same time, NARA will give priority to microfilming records that have research value for a variety of studies or that contain basic information for fields of research in which researchers have demonstrated substantial interest.

(2) The records to be filmed should be reasonably complete and not subject to future additions, especially of appreciable volumes, within the original body of records. Records with pending or future end-of-series additions are appropriate for filming.

(3) The records to be filmed should not have substantial numbers of documents withdrawn because of continuing security classification or privacy or other restriction.

(b) NARA will approve only requests to microfilm a complete body of documents, such as an entire series or a major continuous segment of a very large series which is reasonably divisible. Microfilming a complete body of documents means that all documents within the file unit(s) to be microfilmed will be consecutively copied, from the first to the last page, not skipping any pages in between except for pages that are exact duplicates or blank pages that are not included in a pagination scheme.

(c) NARA will normally approve only requests which include assurances that the project will adhere to the specifications in part 1230 of this chapter which concern microfilm stock standards, index placement, and microfilm processing for permanent records.

(d) NARA will approve only requests which specify that NARA will receive a first generation silver halide duplicate negative containing no splices made from the original camera negative of the microform record created in accordance with part 1230 of this chapter. NARA may waive any of the requirements of this paragraph at its discretion.

(1) NARA may use this duplicate negative microform to make duplicate preservation and reference copies. The copies may be made available for NARA and public use in NARA facili-

ties and programs immediately upon receipt, subject to the limitation in paragraph (d)(2) of this section.

(2) NARA may also sell copies of the microform seven years after filming at the NARA facility is completed, or earlier if there is no commercial distributor. NARA may choose to add its own editorial material to the microform copies which NARA distributes or sells.

(3) Detailed roll lists must be delivered with the microfilm. The lists must give the full range of file titles and a complete list of all file numbers on each roll of microfilm. NARA prefers that the list be provided in a fielded, electronic format to facilitate its use by staff and researchers. If the electronic format is a data file with defined or delimited fields, the records layout identifying the fields, any coded values for fields, and explanations of any delimiters should be transferred with the list.

(4) Microfilm projects may donate to NARA additional indexes and/or finding aids. NARA and the microfilm project will execute a deed of gift that will specify restrictions on NARA's use and dissemination of these products under mutually acceptable terms.

(e) NARA will not approve any request that does not include all of the information required by § 1254.92.

(f) NARA will normally not approve requests to microfilm documents:

(1) Which have previously been microfilmed and made available to the public;

(2) Which have been approved for microfilming by another party; or

(3) Which NARA plans to film as a NARA microfilm publication or which relate closely to other documents previously microfilmed or approved for microfilming by NARA. Exceptions to this provision may be granted at the discretion of NARA.

(g) NARA will normally not approve requests to microfilm the following categories of documents:

(1) Documents which include documents with general or specific restrictions on access that preclude their reproduction;

(2) Documents which include documents which are known to be protected by copyright;

(3) Documents of high intrinsic value which may be handled only by authorized NARA personnel;

(4) Documents in vulnerable physical condition;

(5) Documents having a high research demand and which would have to be denied to others for an extended period of time during the microfilming process. Where possible, NARA will assist requesters in developing filming schedules that avoid the need to close documents for a lengthy period of time; and

(6) Oversize documents, bound volumes, and other formats that would be subject to excessive stress and possible damage from special equipment planned to be used by the requester, as well as documents fastened with grommets, heavy duty staples, miscellaneous fasteners, or wafers and other adhesives that cannot be removed without tearing or breaking documents.

(h) NARA will normally not approve requests from persons or organizations who have failed to produce usable microfilm or to honor commitments made in previous requests, or who have had a previous permission to microfilm documents rescinded because of their conduct.

(i) NARA will not approve requests to microfilm records in NARA facilities in which there is insufficient space available for private microfilming. NARA also will not approve requests where the only space available for filming is in the facility's research room, and such work would disturb researchers. NARA will not move records from a facility lacking space for private microfilming to another NARA facility for that purpose. When a NARA facility does not have enough space to accommodate all the requests made, NARA may schedule separate projects by limiting the time allowed for each particular project or by requiring projects to alternate in the use of the space.

(j) Federal agencies microfilming records in support of the agency's mission may use the space set aside for private microfilming. Agency microfilming takes precedence over private microfilming when there is insufficient space to accommodate both at the same time.

(k) NARA will not approve requests to microfilm records when there is not enough staff to provide the necessary support services, including document preparation, training of private microfilmmers, and monitoring the filming.

(l) NARA will not approve the start of a project to microfilm records until the requestor has agreed in writing to the amount and schedule of fees for any training, microfilm preparation, and monitoring by NARA staff that is necessary to support that specific project. NARA's letter of tentative approval for the project will include an agreement detailing the records in the project and the detailed schedule of fees for NARA services for the project. NARA will give final approval when NARA receives the requestor's signed copy of the agreement.

[52 FR 20081, May 29, 1987, as amended at 64 FR 19905, Apr. 23, 1999]

#### § 1254.96 Microfilm preparation.

(a) As part of its evaluation of a request to microfilm documents, NARA will determine the amount of microfilm preparation that NARA must do before the documents can be microfilmed and the estimated cost of such preparation. The fees for microfilm preparation will be based on direct salary costs (including benefits) and supply costs when NARA staff performs the work. When the work is performed by a NARA contractor, the fees will be the cost to NARA. Microfilm preparation includes:

(1) Removing document fasteners from documents when the fasteners can be removed without damage to the documents; and

(2) Taking any document conservation actions that must be accomplished in order to film the documents, such as document flattening or mending.

(b) NARA will provide the requester detailed information on the fees for microfilm preparation in the letter of approval. Payment of fees will be made in accordance with §1258.14 of this chapter. When a body of documents will require extensive microfilm preparation, a different payment schedule

## § 1254.98

may be established at the discretion of NARA.

[52 FR 20081, May 29, 1987; 52 FR 22415, June 11, 1987, as amended at 59 FR 29195, June 6, 1994; 64 FR 19905, Apr. 23, 1999]

### § 1254.98 Equipment standards.

(a) Because space in many NARA facilities is limited, microfilm/fiche equipment should be operable from a table top unless NARA has given written permission to use free standing/floor model cameras. Only planetary type camera equipment may be used. Automatic rotary cameras and other equipment with automatic feed devices may not be used. Book cradles or other specialized equipment designed for use with bound volumes, oversized documents, or other formats may be approved by NARA on a case-by-case basis. Other camera types not specified in this section may be approved for use on a case-by-case basis.

(b) The power consumption of the equipment normally must not exceed 1.2 kilowatts. Power normally available is 115 volts, 60 hz. Requests for electricity exceeding that normally available must be made at least 90 days in advance.

(c) Equipment having clamps or other devices to exert pressure upon or to affix the document to any surface in a way that might damage the document may not be used.

(d) The equipment must not use a heat generating light source in close enough proximity to the documents to result in their physical distortion or degradation. All sources of ultraviolet light must be filtered.

[52 FR 20081, May 29, 1987; 52 FR 22415, June 11, 1987; as amended at 64 FR 19905, Apr. 23, 1999]

### § 1254.100 Microfilming procedures.

(a) Equipment used must conform to the equipment standards in § 1254.98.

(b) Documents must be handled in accordance with the training and instructions provided by NARA personnel so that documents are not damaged during copying and so that their original order is maintained. Only persons who have attended NARA training will be permitted to handle the documents or supervise microfilming operations. Training will be offered only in Wash-

## 36 CFR Ch. XII (7-1-03 Edition)

ington, DC. NARA will charge the requester fees for training services and these fees will be based on direct salary costs (including benefits) and any related supply costs. Such fees will be specified in the written agreement required for project approval in § 1254.94(l).

(c) Documents from only one file unit may be microfilmed at a time. After reproduction is completed, documents removed from files for microfilming must be returned to their original position in the file container, any fasteners removed to facilitate copying must be refastened, and any tabs placed on the documents to identify items to be copied must be removed.

(d) Documents may not be left unattended on the copying equipment or elsewhere.

(e) Under normal microfilming conditions, actual copying time per sheet must not exceed 30 seconds.

(f) Any lights used with the camera must be turned off when the camera is not in actual operation.

(g) Microfilm equipment may be operated only in the presence of the research room attendant or a designated NARA employee. If NARA places microfilm projects in a common research area with other researchers, the project will not be required to pay for monitoring that is ordinarily provided. If the microfilm project is performed in a research room set aside for copying and filming, NARA will charge the project fees for these monitoring services and these fees will be based on direct salary costs (including benefits). When more than one project share the same space, monitoring costs will be divided equally among the projects. The monitoring service fees will be specified in the written agreement required for project approval in § 1254.94(l).

(h) The equipment normally should be in use each working day that it is in a NARA facility. The director of the NARA facility (as defined in § 1252.2 of this chapter) will decide when equipment must be removed because of lack of regular use. The equipment must be promptly removed upon request of the facility director.

(i) NARA assumes no responsibility for loss or damage to microfilm equipment or supplies left unattended.

(j) NARA will inspect the microform output at scheduled intervals during the project to verify that the processed film meets the microfilm preparation and filming standards required by part 1230 of this chapter. To enable NARA to properly inspect the film, NARA must receive the film within 5 days after it has been processed. The person or organization producing the microfilm will provide NARA with a silver halide duplicate negative of the filmed records (see §1254.94(d)) according to the schedule shown in (k). If the processed film does not meet the standards, NARA may require that the records be re-filmed.

(k) When 10,000 or fewer images are filmed, the person or organization producing the microfilm will provide NARA with a silver halide duplicate negative upon completion of the project. When the project involves more than 10,000 images, a silver halide duplicate negative of the first completed roll or segment of the project reproducing this image count will be provided to NARA for evaluation; subsequent completed segments of the project, in quantities approximating 100,000 or fewer images, will be provided to NARA within 30 days after filming unless NARA approved other arrangements.

[52 FR 20081, May 29, 1987, as amended at 64 FR 19905, Apr. 23, 1999]

**§ 1254.102 Rescinding permission.**

NARA may, at any time, rescind permission to microfilm records:

(a) If the person or organization fails to comply with the microfilming procedures in §1254.100;

(b) If inspection of the processed microfilm reveals persistent problems with the quality of the filming or processing;

(c) If the person or organization fails to proceed with the microfilming or project as indicated in the request, or

(d) If the microfilming project is having an unanticipated adverse effect on the condition of the documents or the space set aside in the NARA facility for microfilming.

(e) If the person or organization fails to pay NARA fees in the agreed to amount or on the agreed to payment schedule.

[52 FR 20081, May 29, 1987, as amended at 64 FR 19906, Apr. 23, 1999]

**PART 1256—RESTRICTIONS ON THE USE OF RECORDS**

Sec.

1256.1 Scope of part.

1256.2 Restrictions on access.

1256.4 Access to records containing personal information.

**Subpart A—General Restrictions**

1256.10 National security information.

1256.12 Information exempted from disclosure by statute.

1256.14 Trade secrets and commercial or financial information.

1256.16 Information which would invade the privacy of an individual.

1256.18 Information related to law enforcement investigations.

**Subpart B—Specific Restrictions**

1256.40 Agency-imposed restrictions.

**Subpart C—Domestic Distribution of United States Information Agency Materials in the National Archives of the United States**

1256.50 Scope of subpart.

1256.52 Purpose.

1256.54 Definition.

1256.56 Transfer of USIA audiovisual records to NARA.

1256.58 Domestic distribution of USIA audiovisual records transferred to NARA.

1256.60 Fees.

AUTHORITY: 44 U.S.C. 2101-2118; 22 U.S.C. 1461(b).

**§ 1256.1 Scope of part.**

This part contains material referred to in §1254.30.

[40 FR 56892, Dec. 5, 1975. Redesignated and amended at 50 FR 15723, 15727, Apr. 19, 1985]

**§ 1256.2 Restrictions on access.**

The use of some archives and donated historical materials transferred to the National Archives of the United States, especially those of recent date, is subject to restrictions prescribed in statute or Executive order, or restrictions specified by the donor or agency from

which the records were transferred and imposed by the Archivist of the United States. Restrictions on access to particular records that have been specified by the donor or transferring agency are known as “specific restrictions.” Restrictions on access that may apply to more than one record group are termed “general restrictions,” and apply to the kinds of information or classes of records designated, regardless of the record group to which such records have been allocated. Both specific and general restrictions have been published in the “Guide to the National Archives of the United States.” (See § 1254.30.) Subparts A and B contain restrictions that have been added or revised since the publication of the latest edition of the Guide.

[40 FR 56892, Dec. 5, 1975. Redesignated at 50 FR 15723, Apr. 19, 1985]

**§ 1256.4 Access to records containing personal information.**

(a) *NARA policy.* Access to archival records containing information access to which would invade the privacy of an individual is restricted by § 1256.16.

(1) NARA may authorize access to such records for the purpose of statistical or quantitative research to qualified persons doing biomedical research under the conditions outlined in this section.

(2) If NARA is able to make a copy of such records with all personal identifiers masked or deleted, NARA will make such a “sanitized” copy of the record available to all researchers in accordance with part 1254 of this chapter.

(3) NARA will not grant access to restricted census and survey records of the Bureau of the Census less than 72 years old containing data identifying individuals enumerated in population censuses in accordance with 44 U.S.C. 2108(b).

(4) NARA will not grant access contrary to a specific restriction to records which have specific restrictions on access imposed by the agency of origin in accordance with § 1256.40.

(b) *Request for access.* Researchers who wish to have access to records the use of which is restricted by § 1256.16 to conduct biomedical research must submit a written request to the Assistant

Archivist for the National Archives (NN), National Archives and Records Administration, Washington, DC 20408. OMB control number 3095-0002 has been assigned to this collection of information requirement. Researchers are encouraged to consult informally NARA prior to submitting the formal request. The request must include the following information:

- (1) Name and mailing address;
- (2) Institutional affiliation and position, if applicable;
- (3) List of published research;
- (4) References from two persons who have first-hand knowledge of the requester’s qualifications to perform the research;
- (5) A statement of the nature of the research to be conducted and any plans for publication or presentation of the research findings;
- (6) A listing of all sources of great funds supporting the research project or its publication;
- (7) A statement of the methodology to be used;
- (8) A statement of the administrative, technical, and physical safeguards to be employed by the researcher to prevent unauthorized use or disclosure of the records;
- (9) A listing of the record groups and series titles to be used; and
- (10) A statement that the researcher will abide by the conditions of access to be prescribed by NARA and that the researcher will assume responsibility for the action of all persons working with the researcher on the project.

(c) *Access Review Committee.* Requests made under paragraph (b) of this section will be reviewed by NARA’s Access Review Committee, which is composed of the Deputy Archivist of the United States, the Assistant Archivist for the National Archives, and the director(s) of the NARA division(s) which has custody of the requested records. The Committee may consult other persons within and outside the Federal Government who are knowledgeable in the research field for assistance in evaluating a request.

(1) The Committee will examine the request to determine:

- (i) Whether the requested information is of such a highly sensitive personal nature that disclosure should not

be permitted even for biomedical statistical or quantitative research;

(ii) Whether the methodology proposed by the requester will permit the researcher to obtain the projected research results without revealing personally identifying information;

(iii) Whether the research results will be published or presented at an academic or research conference;

(iv) Whether the requester is a *bona-fide* biomedical researcher who has previous experience in conducting statistical research projects and publishing articles or books on such research;

(v) Whether the safeguards proposed by the requester will adequately protect the personal information; and

(vi) Whether NARA has sufficient staff and space available to safeguard privacy interests necessary to accommodate the research project.

(2) The decision of the Committee will be made in writing to the requester within 15 workdays after receipt of a completed request. At the discretion of the Committee, the researcher may meet with the Committee to discuss the project or to discuss revising the research proposal to meet possible objections of the Committee.

(d) *Conditions of access.* Researchers who are granted access to restricted records, all others associated with the research project who will have access to personally identifiable information from the records, and the manager of any ADP facility handling the records or data elements containing personal identifiers shall agree in writing to maintain the confidentiality of the information and to adhere to the conditions of access imposed by NARA. NARA may impose some or all of the following conditions of access on any project; additional conditions may be imposed on the use of specific records or on specific projects:

(1) The records may be used only for the purpose of the statistical research and for the statistical reporting of research findings as described in the approved research project. The records may not be used for any other purpose without NARA approval;

(2) The records and copies of any data elements which permit the identification of an individual or which can be

identified with an individual may not be transferred to any person or institution not directly involved with the approved research project;

(3) Reasonable administrative, technical, and physical safeguards, as approved by NARA, to prevent unauthorized use or disclosure of the records shall be established by the researcher and followed by all persons associated with the research project;

(4) When required by NARA, the records shall be consulted at the NARA facility where the records are located;

(5) Any individually identifiable information in the researcher's notes or in authorized copies of the records shall be rendered anonymous by the researcher at the earliest possible time consistent with the purpose of the research project;

(6) Persons who are identified in the records may not be contacted by or on behalf of the researcher;

(7) Prior to publication or public presentation of the data, the final research product(s) shall be provided to the Assistant Archivist for the National Archives for review. NARA's review shall be limited to ensuring that there is no possible identification of individuals in the research findings. NARA will not evaluate the validity of the research findings;

(8) All research notes containing personally identifiable information from privacy-restricted records and/or copies of such records shall, upon completion of the project, be destroyed or returned to NARA, whichever condition NARA has imposed as a condition of access. If the notes and/or copies are destroyed, the researcher shall verify in writing to the Assistant Archivist for the National Archives that the research notes and/or copies have been destroyed.

(e) *Noncompliance with conditions of access.* If NARA discovers that a researcher has violated any of the conditions of access imposed by NARA, NARA shall take steps to revoke the NARA research privileges of that person and shall consult with the NARA legal counsel to determine any other steps to be taken to prevent any further disclosure of the personal information concerned. NARA may also inform

## § 1256.10

the following persons and organizations of the researcher's failure to follow the conditions of use:

- (1) The institution with which the researcher is affiliated, if applicable;
- (2) Persons who served as references in the application for access;
- (3) Organizations which provided grant funds for the project;
- (4) The sponsor of the publication or public presentation; and/or
- (5) Appropriate professional organizations.

[53 FR 6821, Mar. 3, 1988]

### Subpart A—General Restrictions

#### § 1256.10 National security information.

(a) *Records.* Records containing information regarding national defense or foreign policy and properly classified under an Executive order.

(b) *Restrictions.* Such records may be disclosed only in accordance with the provisions of such Executive order and its implementing directive.

(c) *Imposed by.* Archivist of the United States in accordance with 5 U.S.C. 552 and 44 U.S.C. 2108.

[48 FR 6540, Feb. 14, 1983. Redesignated at 50 FR 15723, Apr. 19, 1985]

#### § 1256.12 Information exempted from disclosure by statute.

(a) *Records.* Records containing information which is specifically exempted from disclosure by statute.

(b) *Restrictions.* Such records may be disclosed only in accordance with the provisions of 44 U.S.C. 2108.

(c) *Imposed by.* Archivist of the United States in accordance with 5 U.S.C. 552 and 44 U.S.C. 2108.

[48 FR 6541, Feb. 14, 1983, as amended at 48 FR 45393, Oct. 5, 1983. Redesignated at 50 FR 15723, Apr. 19, 1985]

#### § 1256.14 Trade secrets and commercial or financial information.

(a) *Records.* Records not restricted by statute but which contain trade secrets and commercial or financial information submitted to the government with an expressed or implied understanding of confidentiality.

(b) *Restrictions.* Such records may be disclosed only if:

## 36 CFR Ch. XII (7-1-03 Edition)

(1) The party that provided the information agrees to its release; or

(2) In the judgment of the Archivist of the United States, the passage of time is such that release of the information would not result in substantial competitive harm.

(c) *Imposed by.* Archivist of the United States in accordance with 5 U.S.C. 552 and 44 U.S.C. 2108.

[48 FR 6541, Feb. 14, 1983. Redesignated at 50 FR 15723, Apr. 19, 1985]

#### § 1256.16 Information which would invade the privacy of an individual.

(a) *Records.* Records containing information about a living individual which reveal details of a highly personal nature that the individual could reasonably assert a claim to withhold from the public to avoid a clearly unwarranted invasion of privacy, including but not limited to information about the physical or mental health or the medical or psychiatric care or treatment of the individual, and that—

(1) Contain personal information not known to have been previously made public, and

(2) Relate to events less than 75 years old.

(b) *Restrictions.* Such records may be disclosed only:

(1) To those officers and employees of the agency that transferred the records to the National Archives who have a need for the record in the performance of their official duties;

(2) To those officers and employees of the agency that originated the information in the records who have a need for the records in the performance of their official duties;

(3) To researchers for the purpose of statistical or quantitative research when such researchers have provided the National Archives with adequate written assurance that the record will be used solely as a statistical research or reporting record and that no individually identifiable information will be disclosed; or

(4) To the subject individual or his duly authorized representative (the individual requesting access will be required to furnish reasonable and appropriate identification). Access will not



be granted, however, to records containing the following categories of information:

(i) Investigatory material compiled for law enforcement purposes or for the purpose of determining suitability, eligibility, or qualifications for Federal civilian employment, military service, or Federal contracts if the identity of the source who furnished the information to the Government under an expressed or implied promise of confidentiality is revealed;

(ii) Evaluation material used to determine potential for promotion in the armed services if the identity of the source who furnished the information to the government under an expressed or implied promise of confidentiality is revealed; and

(iii) Security classified material.

(c) *Imposed by.* Archivist of the United States in accordance with 5 U.S.C. 552 and 44 U.S.C. 2108.

[48 FR 6541, Feb. 14, 1983. Redesignated at 50 FR 15723, Apr. 19, 1985]

**§ 1256.18 Information related to law enforcement investigations.**

(a) *Records.* Records compiled for law enforcement purposes.

(b) *Restrictions.* Such records may be disclosed only:

(1) If the release of the information does not interfere with enforcement proceedings, and

(2) If confidential sources and/or confidential information are not revealed, and

(3) If the release of the information would not constitute an unwarranted invasion of personal privacy, and

(4) If confidential investigation techniques are not described, and

(5) If the release of the information would not endanger the safety of law enforcement personnel, or

(6) If, in the judgment of the Archivist of the United States the passage of time is such that:

(i) The safety of persons is not endangered, and

(ii) The public interest in disclosure outweighs the continued need for confidentiality.

(c) *Imposed by.* Archivist of the United States in accordance with 5 U.S.C. 552 and 44 U.S.C. 2108.

[48 FR 6541, Feb. 14, 1983, as amended at 48 FR 45393, Oct. 5, 1983. Redesignated at 50 FR 15723, Apr. 19, 1985]

**Subpart B—Specific Restrictions**

**§ 1256.40 Agency-imposed restrictions.**

Some records in NARA legal custody are covered by restrictions imposed by the agency of origin that are in conformance with the Freedom of Information Act.

[50 FR 15727, Apr. 19, 1985]

**Subpart C—Domestic Distribution of United States Information Agency Materials in the National Archives of the United States**

SOURCE: 62 FR 31725, June 11, 1997, unless otherwise noted.

**§ 1256.50 Scope of subpart.**

This subpart prescribes procedures governing the public availability of audiovisual records and other materials subject to 22 U.S.C. 1461(b) that have been transferred to the National Archives of the United States by the United States Information Agency (USIA).

**§ 1256.52 Purpose.**

This subpart implements section 501 of the United States Information and Educational Exchange Act of 1948 (22 U.S.C. 1461), as amended by section 202 of Public Law 101-246 (104 Stat. 49, Feb. 16, 1990). This subpart prescribes procedures by which the public may inspect and obtain copies of USIA audiovisual records and other materials prepared for dissemination abroad that have been transferred to NARA for preservation and domestic distribution.

**§ 1256.54 Definition.**

For the purposes of this subpart—*Audiovisual records* mean motion picture films, videotapes, and sound recordings, and other materials regardless of physical form or characteristics

**§ 1256.56**

that were prepared for dissemination abroad.

**§ 1256.56 Transfer of USIA audiovisual records to NARA.**

The provisions of 44 U.S.C. 2107 and 36 CFR part 1228 apply to the transfer of USIA audiovisual records to NARA, and to their deposit with the National Archives of the United States. At the time the audiovisual records are transferred to NARA, the Director of USIA, in accordance with §1228.184(e) of this chapter, will also transfer any production or title files bearing on the ownership of rights in the productions in connection with USIA's official overseas programming.

**§ 1256.58 Domestic distribution of USIA audiovisual records transferred to NARA.**

No USIA audiovisual records in the National Archives of the United States that were prepared for dissemination abroad will be available for copying until it has been at least 12 years since such materials were first disseminated abroad, or, in the case of materials prepared for foreign dissemination but not disseminated abroad, until it has been at least 12 years since the preparation of the materials.

(a) *Access to USIA audiovisual records that neither have copyright protection nor contain copyright material.* USIA audiovisual records prepared for dissemination abroad that NARA determines neither have copyright protection nor contain copyrighted material are available for examination and copying in accordance with the regulations set forth in parts 1252, 1253, 1254, 1256, and 1258 of this chapter. In determining whether materials have copyright protection or contain copyrighted material, NARA will rely on information contained within or affixed to individual records (e.g., copyright notices); information contained within relevant USIA production, title, or other files that have been transferred to NARA by USIA; information provided by requesters pursuant to paragraph (b)(2) of this section (e.g., evidence from the Copyright Office that copyright has lapsed or expired); and information provided by copyright or license holders.

**36 CFR Ch. XII (7-1-03 Edition)**

(b) *Reproduction of USIA audiovisual records that either have copyright protection or contain copyrighted material.*

(1) USIA audiovisual records prepared for dissemination abroad that NARA determines may have copyright protection or may contain copyrighted material will be made available for examination in NARA research facilities in accordance with the regulations set forth in this Title.

(2) Copies of USIA audiovisual records prepared for dissemination abroad that NARA determines may have copyright protection or may contain copyrighted material will be provided to persons seeking the release of such materials in the United States once NARA has:

(i) Ensured, in accordance with paragraph (b)(3) of this section, that the persons seeking copies have secured and paid for necessary United States rights and licenses;

(ii) Been provided with evidence from the Copyright Office sufficient to determine that copyright protection in the materials sought, or relevant portions therein, has lapsed or expired; or

(iii) Received a requester's signed certification in accordance with paragraph (b)(4) of this section that the materials sought will be used only for purposes permitted by the Copyright Act of 1976, as amended, including the fair use provisions of 17 U.S.C. 107. No copies of USIA audiovisual records will be provided until the fees authorized under part 1258 of this chapter have been paid to NARA.

(3) If NARA has determined that a USIA audiovisual record prepared for dissemination abroad may have copyright protection or may contain copyrighted material, persons seeking the release of such material in the United States may obtain copies of the material by submitting to NARA written evidence from all copyright and/or license owner(s) that any necessary fees have been paid or waived and any necessary licenses have been secured.

(4) If NARA has determined that a USIA audiovisual record prepared for dissemination abroad may have copyright protection or may contain copyrighted material, persons seeking the release of such material in the United

States may obtain copies of the material by submitting to NARA the following certification statement:

I, (printed name of individual), certify that my use of the copyrighted portions of the (name or title and NARA identifier of work involved) provided to me by the National Archives and Records Administration (NARA), will be limited to private study, scholarship, or research purposes, or for other purposes permitted by the Copyright Act of 1976, as amended. I understand that I am solely responsible for the subsequent use of the copyrighted portions of the work identified above.

(c) In every instance where a copy of an audiovisual record is provided under this subpart, and NARA has determined that the work being reproduced may have copyright protection or may contain copyrighted material, NARA shall provide a warning notice of copyright.

(d) Nothing in this section shall limit NARA's ability to make copies of USIA audiovisual records for preservation, arrangement, repair and rehabilitation, description, exhibition, security, or reference purposes.

#### § 1256.60 Fees.

Copies or reproductions of audiovisual records will only be provided under this subpart upon payment of fees in accordance with 44 U.S.C. 2116(c) and 22 U.S.C. 1461(b)(3).

### PART 1258—FEES

Sec.

1258.1 What is the authority for this part?

1258.2 What does the NARA reproduction fee schedule cover?

1258.4 What reproductions are not covered by the NARA fee schedule?

1258.6 When does NARA provide reproductions without charge?

1258.8 Who pays to have a copy negative made?

1258.10 What is NARA's mail order policy?

1258.12 NARA reproduction fee schedule.

1258.14 What is NARA's payment policy?

1258.16 Effective date.

AUTHORITY: 44 U.S.C. 2116(c) and 2307.

SOURCE: 65 FR 60866, Oct. 13, 2000, unless otherwise noted.

#### § 1258.1 What is the authority for this part?

(a) 44 U.S.C. 2116(c) authorizes NARA to charge a fee for making or authenticating copies or reproductions of materials transferred to the Archivist's custody. This fee is to be "fixed by the Archivist at a level which will recover, so far as practicable, all elements of such costs and may, in the Archivist's discretion, include increments for the estimated replacement costs of equipment." The fees collected for reproductions are to be paid into and expended as part of the National Archives Trust Fund.

(b) 44 U.S.C. 2307 authorizes the Archivist of the United States, as Chairman of the National Archives Trust Fund Board, to sell copies of microfilm publications at a price that will cover their cost, plus 10 percent.

#### § 1258.2 What does the NARA reproduction fee schedule cover?

The NARA reproduction fee schedule in § 1258.12 covers reproduction of:

(a) NARA archival records, donated historical materials, Presidential records, and Nixon Presidential historical materials except as otherwise provided in §§ 1258.4 and 1258.6. Some reproduction services listed in § 1258.12 may not be available at all NARA facilities;

(b) Other Federal records stored in NARA Federal records centers, except when NARA and the agency that transferred the records have agreed to apply that agency's fee schedule; and

(c) Records filed with the Office of the Federal Register.

#### § 1258.4 What reproductions are not covered by the NARA fee schedule?

The following categories are not covered by the NARA fee schedule in § 1258.12.

(a) Still photography, including aerial film, and oversize maps and drawings. Information on the availability and prices of reproductions of records held in the Special Media Archives Services Division (NWCS), 8601 Adelphi Rd., College Park, MD 20740-6001, and in the Presidential libraries and regional archives (see 36 CFR 1253.3 and 36 CFR 1253.7 for addresses) may be obtained from the unit which has the original records.

§ 1258.6

36 CFR Ch. XII (7-1-03 Edition)

(b) Motion picture, sound recording, and video holdings of the National Archives and Presidential libraries. Information on the availability of and prices for reproduction of these materials are available from the Special Media Archives Services Division (NWCS), 8601 Adelphi Rd., Room 3340, College Park, MD 20740-6001, or from the Presidential library which has such materials (see 36 CFR 1253.3 for addresses).

(c) Electronic records. Information on the availability of and prices for duplication are available from the Electronic and Special Media Records Services Division (NWME), 8601 Adelphi Rd., Room 5320, College Park, MD 20740-6001, or from the Presidential library which has such materials (see 36 CFR 1253.3 for addresses).

(d) Reproduction of the following types of records using the specified order form:

Type of record and order form	Price
(1) Passenger arrival lists (order form NATF Form 81) .....	\$17.25
(2) Federal Census requests (order form NATF Form 82) .....	17.50
(3) Eastern Cherokee applications to the Court of Claims (order form NATF Form 83) .....	17.50
(4) Land entry records (order form NATF 84) .....	17.75
(5) Bounty land warrant application files (order form NATF Form 85) .....	17.25
(6) Pension files more than 75 years old (order form NATF Form 85)—complete file .....	37.00
(7) Pension documents packet (order form NATF Form 85) .....	14.75
(8) Military service files more than 75 years old (order form NATF Form 86) .....	17.00

(e) National Archives Trust Fund Board publications, including microfilm publications. Prices are available from the Customer Service Center (NWCC2), 8601 Adelphi Rd., Room 1000, College Park, MD 20740-6001.

(f) Reproductions of NARA operational records made in response to FOIA requests under part 1250 of this chapter.

(g) Orders for expedited service ("rush" orders) for reproduction of still pictures and motion picture and video recordings among the holdings of a Presidential library. Orders may be accepted on an expedited basis by the library when the library determines that sufficient personnel are available to handle such orders or that the NARA contractor making the reproduction can provide the service. Rush orders are subject to a surcharge to cover the additional cost of providing expedited service.

(h) Orders requiring additional expense to meet unusual customer specifications such as the use of special techniques to make a photographic copy more legible than the original document, or unusual format or background requirement for negative

microfilm. Fees for these orders are computed for each order.

**§ 1258.6 When does NARA provide reproductions without charge?**

NARA does not charge a fee for reproduction or certification in the instances described in this section, if the reproduction is not a color reproduction. Color reproductions are furnished to the public and the Government only on a fee basis.

(a) When NARA furnishes copies of documents to other elements of the Federal Government. However, a fee may be charged if the appropriate director determines that the service cannot be performed without reimbursement;

(b) When NARA wishes to disseminate information about its activities to the general public through press, radio, television, and newsreel representatives;

(c) When the reproduction is to furnish the donor of a document or other gift with a copy of the original;

(d) When the reproduction is for individuals or associations having official voluntary or cooperative relations with NARA in its work;

(e) When the reproduction is for a foreign, State, or local government or an international agency and furnishing it without charge is an appropriate courtesy;

(f) For records of other Federal agencies in NARA Federal records centers only:

(1) When furnishing the service free conforms to generally established business custom, such as furnishing personal reference data to prospective employers of former Government employees;

(2) When the reproduction of not more than one copy of the document is required to obtain from the Government financial benefits to which the requesting person may be entitled (*e.g.*, veterans or their dependents, employees with workmen's compensation claims, or persons insured by the Government);

(3) When the reproduction of not more than one copy of a hearing or other formal proceeding involving security requirements for Federal employment is requested by a person directly concerned in the hearing or proceeding; and

(4) When the reproduction of not more than one copy of a document is for a person who has been required to furnish a personal document to the Government (*e.g.*, a birth certificate required to be given to an agency where the original cannot be returned to the individual).

**§ 1258.8 Who pays to have a copy negative made?**

Requests for photographs of materials for which no copy negative is on file are handled as follows:

(a) The customer is charged to make the copy negative, except in cases where NARA wishes to retain the negative for its own use.

(b) When no fee is charged the negative becomes the property of NARA. When a fee is charged the negative becomes the property of the customer.

**§ 1258.10 What is NARA's mail order policy?**

(a) There is a minimum fee of \$10.00 per order for reproductions that are sent by mail to the customer.

(b) Orders to addresses in the United States are sent either first class or UPS depending on the weight of the order and availability of UPS service. When a customer requests special mailing services (such as Express Mail or registered mail) and/or shipment to a foreign address, the cost of the special service and/or additional postage for foreign mail is added to the cost of the reproductions.

**§ 1258.12 NARA reproduction fee schedule.**

(a) Certification: \$6.

(b) Electrostatic copying (in order to preserve certain records which are in poor physical condition, NARA may restrict customers to photographic or microfilm copies instead of electrostatic copies):

Service	Fee
(1) Paper-to-paper copies (up to and including 11 in. by 17 in.) made by the customer on a NARA self-service copier .....	1\$0.15
(2) Paper-to-paper copies (up to and including 11 in. by 17 in.) made by NARA staff .....	10.50
(3) Oversized electrostatic copies .....	22.70
(4) Electrostatic copies (22 in. by 34 in.) .....	12.70
(5) Microfilm or microfiche to paper copies made by the customer on a NARA self-service copier .....	10.30
(6) Microfilm or microfiche to paper copies made by NARA staff .....	11.90

<sup>1</sup> Per copy.  
<sup>2</sup> Per linear foot.

**§ 1258.14**

**36 CFR Ch. XII (7-1-03 Edition)**

(c) Original negative microfilm (paper-to-microfilm): \$0.70 per image.

(d) Self-service video copying in the Motion Picture, Sound and Video Research Room:

Service	Fee
(1) Initial 90-min use of video copying station with 120-minute videocassette .....	\$9.75
(2) Additional 90-minute use of video copying station with no videocassette .....	6.25
(3) Blank 120-minute VHS videocassette .....	3.50

(e) Self-service Polaroid prints: \$5.75 per print.

(f) Unlisted processes: For reproductions not covered by this fee schedule, see also §1258.4. Fees for other reproduction processes are computed upon request.

(b) *Timing.* Fees must be paid in advance except when the appropriate director approves a request for handling them on an account receivable basis. Purchasers with special billing requirements must state them when placing orders and must complete any special forms for NARA approval in advance.

**§ 1258.14 What is NARA's payment policy?**

(a) *Form of payment.* Fees may be paid in cash, by check or money order made payable to the National Archives Trust Fund, or by selected credit cards. Payments from outside the United States must be made by international money order payable in U.S. dollars or a check drawn on a U.S. bank.

**§ 1258.16 Effective date.**

The fees in this part are effective on November 13, 2000. If your order was received by NARA before this effective date, we will charge the fees in effect at the time the order was received.

## SUBCHAPTER D—DECLASSIFICATION

### PART 1260—DECLASSIFICATION OF NATIONAL SECURITY INFORMATION

#### Subpart A—General Information

Sec.

- 1260.1 What is the purpose of this regulation?
- 1260.2 Definitions.
- 1260.4 What NARA holdings are covered by this regulation?
- 1260.6 What is the authority for this regulation?

#### Subpart B—Responsibilities

- 1260.20 Who is responsible for the declassification of national security-classified Executive Branch information that has been accessioned by NARA?
- 1260.22 Who is responsible for the declassification of national security-classified White House originated information in NARA's holdings?
- 1260.24 Who is responsible for declassification of foreign government information in NARA's holdings?
- 1260.26 Who is responsible for issuing special procedures for declassification of information concerning intelligence or cryptography in NARA's holdings?
- 1260.28 Who is responsible for declassifying records that contain nuclear-related information classified under the Atomic Energy Act of 1954, as amended, commonly referred to as Restricted Data and Formerly Restricted Data?

#### Subpart C—Systematic Review

- 1260.40 How will records at NARA be reviewed for declassification?
- 1260.42 What are the procedures for agency personnel to review records at a NARA facility?
- 1260.44 Will NARA loan accessioned records back to the agencies to conduct declassification review?

#### Subpart D—Mandatory Review

##### EXECUTIVE BRANCH RECORDS

- 1260.50 What procedures does NARA follow when it receives a request for Executive Branch records under mandatory review?
- 1260.52 What are agency responsibilities when it receives a mandatory review request forwarded by NARA?
- 1260.54 What is the appeal process when a mandatory review request for Executive Branch information is denied?

##### WHITE HOUSE ORIGINATED INFORMATION

- 1260.56 Is White House originated information subject to mandatory review?
- 1260.58 What are the procedures for requesting a mandatory review of White House originated information?
- 1260.60 What are agency responsibilities with regard to mandatory review requests for White House originated information?
- 1260.62 What is the appeal process when a mandatory review request for White House originated information is denied?

#### Subpart E—Reclassification

- 1260.70 Can Executive Branch information be reclassified?
- 1260.72 Can White House information be reclassified?
- 1260.74 Can NARA appeal a request to reclassify information?

AUTHORITY: 44 U.S.C. 2101 to 2118; 5 U.S.C. 552; E.O. 12958, 60 FR 19825, 3 CFR, 1995 Comp., p.333; E.O. 13142, 64 FR 66089, 3 CFR, 1999 Comp., p. 236.

SOURCE: 65 FR 34974, June 1, 2000, unless otherwise noted.

#### Subpart A—General Information

##### § 1260.1 What is the purpose of this regulation?

This regulation defines the responsibilities of NARA and other Federal agencies for declassification of national security classified information in the holdings of NARA. This part also provides procedures for conducting systematic reviews of NARA holdings and for processing mandatory review requests for NARA holdings. Regulations for researchers wishing to request Federal records under the Freedom of Information Act (FOIA) or under mandatory review can be found in 36 CFR 1254.38.

##### § 1260.2 Definitions.

- (a) *Systematic declassification review* means the review for declassification of national security-classified information contained in records that have been determined by the Archivist of the United States to have permanent value in accordance with 44 U.S.C. 2107.
- (b) *Mandatory declassification review* means the review for declassification

## § 1260.4

of national security-classified information in response to a request for declassification that meets the requirements under section 3.6 of Executive Order 12958.

### **§ 1260.4 What NARA holdings are covered by this regulation?**

The NARA holdings covered by this regulation are records legally transferred to the National Archives and Records Administration (NARA), including Federal records accessioned into the National Archives of the United States; Presidential records; Nixon Presidential materials; and donated historical materials in Presidential Libraries and in the National Archives of the United States.

### **§ 1260.6 What is the authority for this regulation?**

Declassification of and public access to national security information is governed by Executive Order 12958 of April 17, 1995 (3 CFR 1995 Comp., p. 333), Executive Order 13142 of November 19, 1999 (3 CFR 1999 Comp., p. 236), and by the Information Security Oversight Office Implementing Directive for Executive Order 12958 (32 CFR Part 2001).

## **Subpart B—Responsibilities**

### **§ 1260.20 Who is responsible for the declassification of national security-classified Executive Branch information that has been accessioned by NARA?**

(a) Consistent with the requirements of section 3.4 of Executive Order 12958 and Executive Order 13142 on automatic declassification, the originating agency is responsible for its declassification, but may delegate declassification authority to NARA in the form of declassification guidance.

(b) If an agency does not delegate declassification authority to NARA, the agency is responsible for reviewing the records prior to the date that the records become eligible for automatic declassification.

(c) NARA is responsible for the declassification of records of a defunct agency that has no successor in func-

## 36 CFR Ch. XII (7–1–03 Edition)

tion. NARA will consult with agencies having primary subject matter interest before making declassification determinations.

### **§ 1260.22 Who is responsible for the declassification of national security-classified White House originated information in NARA's holdings?**

(a) NARA is responsible for declassification of information from a previous administration that was originated by:

- (1) The President;
- (2) The White House staff;
- (3) Committees, commissions, or boards appointed by the President; or
- (4) Others specifically providing advice and counsel to the President or acting on behalf of the President.

(b) NARA will consult with agencies having primary subject matter interest before making declassification determinations.

### **§ 1260.24 Who is responsible for declassification of foreign government information in NARA's holdings?**

(a) The agency that received or classified the information is responsible for its declassification.

(b) In the case of a defunct agency, NARA is responsible for declassification of foreign government information in its holdings and will consult with the agencies having primary subject matter interest before making declassification determinations.

### **§ 1260.26 Who is responsible for issuing special procedures for declassification of information concerning intelligence or cryptography in NARA's holdings?**

(a) The Director of Central Intelligence is responsible for issuing special procedures for declassification of information concerning intelligence activities and intelligence sources and methods.

(b) The Secretary of Defense is responsible for issuing special procedures for declassification of information concerning cryptography.



**§ 1260.28 Who is responsible for declassifying records that contain nuclear-related information classified under the Atomic Energy Act of 1954, as amended, commonly referred to as Restricted Data and Formerly Restricted Data?**

Only designated officials within the Department of Energy may declassify records containing Restricted Data. Records containing Formerly Restricted Data may only be declassified by designated individuals within the Department of Energy or by appropriate individuals in the Department of Defense.

**Subpart C—Systematic Review**

**§ 1260.40 How will records at NARA be reviewed for declassification?**

(a) Consistent with the requirements of section 3.4 of Executive Order 12958 and Executive Order 13142 on automatic declassification, NARA staff will systematically review for declassification records for which the originating agencies have provided declassification guidance. The originating agency must review records for which it has not provided declassification guidance.

(b) Agencies may choose to review their own records that have been accessioned by NARA by sending personnel to the NARA facility where the records are located to conduct the declassification review.

**§ 1260.42 What are the procedures for agency personnel to review records at a NARA facility?**

(a) NARA will make the records available to properly cleared agency reviewers. NARA will provide space for agency reviewers in the facility in which the records are located as space is available. NARA will also provide training and guidance for agency reviewers on the proper handling of archival materials.

(b) Agency reviewers must:

(1) Follow NARA security regulations and abide by NARA procedures for handling archival materials;

(2) Follow NARA procedures for identifying and marking documents that cannot be declassified; and

(3) Obtain permission from NARA before bringing into a NARA facility

computers, scanners, tape recorders, microfilm readers and other equipment necessary to view or copy records. NARA will not allow the use of any equipment that poses an unacceptable risk of damage to archival materials. See 36 CFR 1254.26 and 1254.27 for more information on acceptable equipment.

**§ 1260.44 Will NARA loan accessioned records back to the agencies to conduct declassification review?**

In rare cases, when agency reviewers cannot be accommodated at a NARA facility, NARA will consider a request to loan records back to an originating agency in the Washington, DC, metropolitan area for declassification review. Each request will be judged on a case-by-case basis. The requesting agency must:

(a) Ensure that the facility in which the documents will be stored and reviewed passes a NARA inspection to ensure that the facility maintains:

(1) The correct archival environment for the storage of permanent records; and

(2) The correct security conditions for the storage and handling of national security-classified materials.

(b) Meet NARA requirements for ensuring the safety of the records;

(c) Abide by NARA procedures for handling of archival materials;

(d) Identify and mark documents that cannot be declassified in accordance with NARA procedures; and

(e) Obtain NARA approval of any equipment such as scanners, copiers, or cameras to ensure that they do not pose an unacceptable risk of damage to archival materials.

**Subpart D—Mandatory Review**

EXECUTIVE BRANCH RECORDS

**§ 1260.50 What procedures does NARA follow when it receives a request for Executive Branch records under mandatory review?**

(a) If the requested records are less than 25 years old, NARA refers copies of the records to the originating agency and to agencies that have equities in the information for declassification review. Agencies may also send personnel to a NARA facility where the

§ 1260.52

36 CFR Ch. XII (7-1-03 Edition)

records are located to conduct a declassification review, or may delegate declassification authority to NARA in the form of declassification guidance.

(b) If the requested records are more than 25 years old, NARA will review the records using systematic declassification guidance provided by the originating agency and agencies having equities in the information. If the originating agency, or agencies having equities in the information have not provided systematic declassification guidance, or if there is a question regarding the guidance, NARA will refer any requested documents it is unable to declassify to the appropriate agency or agencies for declassification determinations.

(c) When the records were originated by a defunct agency that has no successor agency, NARA is responsible for making the declassification determinations, but will consult with agencies having primary subject matter interest.

(d) In every case, NARA will acknowledge receipt of the request and inform the requester of the action taken. If additional time is necessary to make a declassification determination on material for which NARA has delegated authority, NARA will tell the requester how long it will take to process the request. NARA will also tell the requester if part or all of the requested information is referred to other agencies for declassification review, subject to section 3.7(a) of Executive Order 12958.

**§ 1260.52 What are agency responsibilities when it receives a mandatory review request forwarded by NARA?**

(a) The agency must make a determination within 180 calendar days after receiving the request or inform NARA of the additional time needed to process the request. If an initial decision has not been made on the request within 1 year after the original date of the request, the requester may appeal to the Interagency Security Classification Appeals Panel (ISCAP).

(b) The agency must notify NARA of any other agency to which it forwards the request in those cases requiring the

declassification determination of another agency.

(c) The agency must return to NARA a complete copy of each declassified document with the agency determination. If documents cannot be declassified in their entirety, the agency must return to NARA a copy of the documents with those portions that must be withheld clearly marked.

(d) The agency must also furnish, for transmission to the requester, a brief statement of the reasons the requested information cannot be declassified and a statement of the requester's right to appeal the decision, along with the procedures for filing an appeal. The agency must also supply for transmission to the requester a contact name and title and the address where the appeal must be sent.

**§ 1260.54 What is the appeal process when a mandatory review request for Executive Branch information is denied?**

(a) If an agency denies a declassification request under mandatory review, the requester may appeal directly to the appeal authority at that agency.

(b) If requested by the agency, NARA will supply the agency with:

(1) Copies of NARA's letter to the requester transmitting the agency denial; and

(2) Copies of any documents denied in part that were furnished to the requester.

(c) The agency appeal authority must notify NARA in writing of the final determination and of the reasons for any denial.

(d) The agency must furnish to NARA a complete copy of any document they released to the requester only in part, clearly marked to indicate the portions that remain classified. NARA will give the requester a copy of any notifications from the agencies that describe what information has been denied and what the requesters appeal rights are.

(e) In the case of an appeal for information originated by a defunct agency, NARA will notify the requester of the results and furnish copies of documents declassified in full and in part. If the request cannot be declassified in its entirety, NARA will send the requester a brief statement of why the requested

information cannot be declassified and a notice of the right to appeal the determination within 60 calendar days to the Deputy Archivist of the United States, National Archives and Records Administration, 8601 Adelphi Road, College Park, MD 20740-6001.

WHITE HOUSE ORIGINATED INFORMATION

**§ 1260.56 Is White House originated information subject to mandatory review?**

White House originated information of former Presidents is subject to mandatory review consistent with the Presidential Records Act, 44 U.S.C. 2203, the Presidential Recordings and Materials Preservation Act, 44 U.S.C. 2111 note, and any deeds of gift that pertain to the materials or the respective Presidential administrations pursuant to 44 U.S.C. 2107 and 2111. Unless precluded by such laws or agreements, White House originated information is subject to mandatory or an equivalent agency review for current classification when the materials have been archivally processed or can be identified with specificity. However, records covered by the Presidential Records Act are closed for 5 years after the end of the Presidential administration, or until an integral file segment has been archivally processed, whichever occurs first, pursuant to 44 U.S.C. 2204.

**§ 1260.58 What are the procedures for requesting a mandatory review of White House originated information?**

(a) NARA will promptly acknowledge to the requester the receipt of a request for White House originated information.

(b) If the requested information is less than 25 years old, NARA will consult with agencies having primary subject matter interest. NARA will forward copies of the requested materials to the agencies and request their recommendations regarding declassification.

(c) If the requested records are more than 25 years old, NARA will review the records using systematic declassification guidance provided by the originating agency and agencies having equities in the information. If the originating agency, or agencies having equ-

ities in the information have not provided systematic declassification guidance, or if there is a question regarding the guidance, NARA will refer any requested documents it is unable to declassify to the appropriate agency or agencies for their recommendations regarding declassification.

(d) NARA will notify the requester of the results and furnish copies of the documents declassified in full and in part. If the requested records are not declassified in their entirety, NARA will send the requester a brief statement of the reasons the information cannot be declassified and a notice of the right to appeal the determination within 60 calendar days to the Deputy Archivist of the United States, National Archives and Records Administration, 8601 Adelphi Road, College Park, MD 20740-6001.

**§ 1260.60 What are agency responsibilities with regard to mandatory review requests for White House originated information?**

When an agency receives a mandatory review request from NARA for consultation on declassification of White House originated material, whether it is an initial request or an appeal, the agency must:

(a) Advise the Archivist whether the information should be declassified in whole or in part or should continue to be exempt from declassification;

(b) Provide NARA a brief statement of the reasons for any denial of declassification; and

(c) Return all reproductions referred for consultation, including a complete copy of each document that should be released only in part, clearly marked to indicate the portions that remain classified.

**§ 1260.62 What is the appeal process when a mandatory review request for White House originated information is denied?**

(a) When the Deputy Archivist of the United States receives an appeal, he/she will review the decision to deny the information and consult with the appellate authorities in the agencies having primary subject matter interest in the information.

(b) NARA will notify the requester of the determination and make available

## § 1260.70

any additional information that has been declassified as a result of the requester's appeal.

(c) NARA will also notify the requester of the right to appeal denials of access to the Executive Secretary of the Interagency Security Classification Appeals Panel, Attn: Mandatory Review Appeals, c/o Information Security Oversight Office, National Archives and Records Administration, 700 Pennsylvania Avenue, NW, Room 18N, Washington, DC 20408.

### Subpart E—Reclassification

#### § 1260.70 Can Executive Branch information be reclassified?

(a) An agency may ask NARA to temporarily close, re-review, and possibly reclassify records and donated historical materials originated by the agency. Records that were declassified in accordance with E.O. 12958 (or predecessor orders) may be reclassified only if the information is less than 25 years old and has not been previously disclosed to the public. Agencies must submit in writing requests to reclassify Executive Branch records to the Assistant Archivist for Records Services—Washington, DC, National Archives and Records Administration, 8601 Adelphi Road, College Park, MD 20740-6001. Requests to reclassify information in Presidential libraries must be submitted in writing to the Assistant Archivist for Presidential Libraries, National Archives and Records Administration, 8601 Adelphi Road, College Park, MD 20740-6001. In the request, the agency must:

(1) Identify the records or donated materials involved as specifically as possible;

## 36 CFR Ch. XII (7-1-03 Edition)

(2) Explain the reason the re-review and possible reclassification may be necessary; and

(3) Provide any information the agency may have concerning any previous public disclosure of the information.

(b) If the urgency of the request precludes a written request, an authorized agency official may make a preliminary request by telephone and follow up with a written request within 5 workdays.

#### § 1260.72 Can White House originated information be reclassified?

An agency may ask NARA to temporarily close, re-review, and possibly reclassify White House originated information that has been declassified in accordance with E.O. 12958 (or predecessor orders) only if it has not been previously disclosed to the public. The agency must follow the same procedures as a request for reclassification of agency originated information in 36 CFR 1260.70, but it must submit the request to the Assistant Archivist for Presidential Libraries, National Archives and Records Administration, 8601 Adelphi Road, College Park, MD 20740-6001.

#### § 1260.74 Can NARA appeal a request to reclassify information?

NARA may appeal to the Director of the Information Security Oversight Office any re-review or reclassification request from an agency when, in the Archivist's opinion, the facts of previous disclosure suggest that such action is unwarranted or unjustified. NARA will notify the requesting agency that it is appealing the request at the same time that it initiates the appeal.

## SUBCHAPTER E—PRESIDENTIAL RECORDS

### PART 1270—PRESIDENTIAL RECORDS

#### Subpart A—General Provisions

Sec.

- 1270.10 Scope of part.
- 1270.12 Application.
- 1270.14 Definitions.

#### Subpart B—Actions Taken on Behalf of Former Presidents

- 1270.20 Designation of person or persons to act for former President.
- 1270.22 When Archivist may act for former President.

#### Subpart C—Disposal of Presidential Records

- 1270.30 Disposal of Presidential Records by incumbent President.
- 1270.32 Disposal of Presidential Records in the custody of the Archivist.

#### Subpart D—Access to Presidential Records

- 1270.40 Identification of restricted records.
- 1270.42 Denial of access to public; right to appeal.
- 1270.44 Exceptions to restricted access.
- 1270.46 Notice of intent to disclose Presidential records.

#### Subpart E—Presidential Records Compiled for Law Enforcement Purposes

- 1270.50 Consultation with law enforcement agencies.

AUTHORITY: The Presidential Records Act of 1978, Pub. L. 95-591, 92 Stat. 2523-27, as amended by the National Archives and Records Administration Act of 1984, Pub. L. 98-497, sec. 107(b)(7), 98 Stat. 2287 (1984) (codified at 44 U.S.C. 2201-07).

SOURCE: 53 FR 50404, Dec. 15, 1988, unless otherwise noted.

#### Subpart A—General Provisions

##### § 1270.10 Scope of part.

These regulations implement the provisions of the Presidential Records Act of 1978, Pub. L. No. 95-591, 92 Stat. 2523-27, as amended by Pub. L. No. 98-497, sec. 107(b)(7), 98 Stat. 2287 (1984) (codified at 44 U.S.C. 2201-07), by setting forth the policies and procedures governing preservation, protection, and

disposal of, and access to Presidential and Vice-Presidential records created during a term of office of the President or Vice President beginning on or after January 20, 1981. Nothing in these regulations is intended to govern procedures for assertion of, or response to, any constitutionally based privilege which may be available to an incumbent or former President.

##### § 1270.12 Application.

(a) These regulations apply to all Presidential records created during a term of office of the President beginning on or after January 20, 1981.

(b) Vice-Presidential records shall be subject to the provisions of this part in the same manner as Presidential records. The Vice President's duties and responsibilities, with respect to Vice-Presidential records, shall be the same as the President's duties and responsibilities with respect to Presidential records. The Archivist's authority with respect to Vice-Presidential records shall be the same as the Archivist's authority with respect to Presidential records, except that the Archivist may, when he determines it to be in the public interest, enter into an agreement with a non-Federal archival repository for the deposit of Vice-Presidential records.

##### § 1270.14 Definitions.

For the purposes of this part—

(a) The terms *documentary material*, *Presidential records*, *personal records*, *Archivist*, and *former President* have the meanings given them by 44 U.S.C. 2201 (1)-(5), respectively.

(b) The term *agency* has the meaning given it by 5 U.S.C. 551(1) (A)-(D) and 552(f).

(c) The term *Presidential archival depository* has the meaning given it by 44 U.S.C. 2101(1).

(d) The term *Vice-Presidential records* means documentary materials, or any reasonably segregable portion thereof, created or received by the Vice President, his immediate staff, or a unit or individual of the Office of the Vice President whose function is to advise and assist the Vice President, in the

## § 1270.20

course of conducting activities which relate to or have an effect upon the carrying out of the constitutional, statutory, or other official or ceremonial duties of the Vice President. The term includes documentary materials of the kind included under the term *Presidential records*.

(e) The term *filed* means the date something is received in the office of the official to whom it is addressed.

### Subpart B—Actions Taken on Behalf of Former Presidents

#### § 1270.20 Designation of person or persons to act for former President.

(a) A President or former President may designate some person or persons to exercise, upon death or disability of the President or former President, any or all of the discretion or authority granted to the President or former President by chapter 22 of title 44 U.S.C.

(b) When a President or former President designates a person or persons to act for him pursuant to paragraph (a) of this section, this designation shall be effective only if the Archivist has received notice of the designation before the President or former President dies or is disabled.

(c) The notice required by paragraph (b) of this section shall be in writing, and shall include the following information:

(1) Name(s) of the person or persons designated to act for the President or former President;

(2) The current addresses of the person or persons designated; and

(3) The records, identified with reasonable specificity, over which the designee(s) will exercise discretion or authority.

#### § 1270.22 When Archivist may act for former President.

In those instances where a President has specified, in accordance with 44 U.S.C. 2204(a), restrictions on access to Presidential records, but has not made a designation under § 1270.20 of this subpart, the Archivist shall, upon the death or disability of a President or former President, exercise the discretion or authority granted to a Presi-

## 36 CFR Ch. XII (7-1-03 Edition)

dent or former President by 44 U.S.C. 2204.

### Subpart C—Disposal of Presidential Records

#### § 1270.30 Disposal of Presidential records by incumbent President.

A President may, while in office, dispose of any Presidential records which in his opinion lack administrative, historical, informational, or evidentiary value if one of the following two sets of requirements is satisfied:

(a)(1) The President has obtained the written views of the Archivist concerning the proposed disposal; and

(2) The Archivist states in his written views to the President that he does not intend to request, with respect to the President's proposed disposal of Presidential records, the advice of the Committees on Rules and Administration and Governmental Affairs of the Senate, and the Committees on House Administration and Government Operations of the House of Representatives because he does not consider—

(i) The records proposed for disposal to be of special interest to the Congress; or

(ii) Consultation with the Congress concerning the proposed disposal to be in the public interest; or

(b)(1) The President has obtained the written views of the Archivist concerning the proposed disposal;

(2) The Archivist states in his written views either—

(i) That the records proposed for disposal may be of special interest to the Congress; or

(ii) That consultation with the Congress concerning the proposed disposal is in the public interest; and

(3) The President submits copies of the proposed disposal schedule to the Committees on Rules and Administration and Governmental Affairs of the Senate and the Committees on House Administration and Government Operations of the House of Representatives at least 60 calendar days of continuous session of Congress in advance of the proposed disposal date. For the purpose of this section, continuity of session is broken only by an adjournment of Congress *sine die*, and the days on which either House is not in session because of

an adjournment of more than 3 days to a day certain are excluded in the computation of the days in which Congress is in continuous session.

**§ 1270.32 Disposal of Presidential Records in the custody of the Archivist.**

(a) The Archivist may dispose of Presidential records which he has appraised and determined to have insufficient administrative, historical, informational, or evidentiary value to warrant their continued preservation.

(b) When Presidential records are scheduled for disposal pursuant to paragraph (a) of this section, the Archivist shall publish a notice of this disposal in the FEDERAL REGISTER at least 60 days before the proposed disposal date.

(c) The notice required by paragraph (b) of this section, shall include the following:

(1) A reasonably specific description of the records scheduled for disposal; and

(2) A concise statement of the reason for disposal of the records.

(d) Publication in the FEDERAL REGISTER of the notice required by paragraph (b) of this section shall constitute a final agency action for purposes of review under chapter 7 of title 5 U.S.C. (5 U.S.C. 701-706).

**Subpart D—Access to Presidential Records**

**§ 1270.40 Identification of restricted records.**

(a) If a President, prior to the conclusion of his term of office or last consecutive term of office, as the case may be, specifies durations, not to exceed 12 years, for which access to certain information contained in Presidential records shall be restricted, in accordance with 44 U.S.C. 2204, the Archivist or his designee shall identify the Presidential records affected, or any reasonably segregable portion thereof, in consultation with that President or his designated representative(s).

(b) The Archivist shall restrict public access to the information contained in those records identified as affected until—

(1) The date on which the former President waives the restriction on disclosure of the record or information contained within;

(2) The expiration of the period of restriction specified under 44 U.S.C. 2204(a) for the category of information under which a certain record, or a portion thereof, was restricted; or

(3) The Archivist has determined that the former President or an agent of the former President has placed in the public domain through publication a restricted record or a reasonably segregable portion thereof, if this date is earlier than either of the dates specified in paragraph (b)(1) or (2) of this section.

**§ 1270.42 Denial of access to public; right to appeal.**

(a) Any person denied access to a Presidential record (hereinafter *the requester*) because of a determination that the record or a reasonably segregable portion thereof was (1) properly restricted under 44 U.S.C. 2204(a), and (2) not placed in the public domain by the former President or his agent, may file an administrative appeal with the Assistant Archivist for Presidential Libraries (NL), Washington, DC 20408.

(b) Appeals shall be filed no later than 10 working days after the requester receives written notification that access to Presidential records has been denied.

(c) Appeals shall be in writing and shall set forth the reason(s) why the requester believes access to the records sought should be allowed. The requester shall identify the specific records sought.

(d) Upon receipt of an appeal, the Assistant Archivist for Presidential Libraries shall have 30 working days from the date an appeal is filed to consider the appeal and to respond in writing to the requester. The Assistant Archivist's response shall state whether or not the Presidential records requested are to be released and the basis for this determination. The decision of the Assistant Archivist to withhold release of Presidential records is final and not subject to judicial review.

## § 1270.44

36 CFR Ch. XII (7-1-03 Edition)

### § 1270.44 Exceptions to restricted access.

(a) Notwithstanding any restrictions on access imposed pursuant to section 2204 or these regulations, and subject to any rights, defenses, or privileges which the United States or any agency or person may invoke, Presidential records shall be made available in the following instances:

(1) Pursuant to subpoena or other judicial process properly issued by a court of competent jurisdiction for the purposes of any civil or criminal investigation or proceeding;

(2) To an incumbent President if the records sought contain information which is needed for the conduct of current business of his office and is not otherwise available;

(3) To either House of Congress, or, to the extent of matter within its jurisdiction, to a Congressional committee or subcommittee if the records sought contain information which is needed for the conduct of business within its jurisdiction and is not otherwise available.

(b) Requests by an incumbent President, a House of Congress, or a Congressional committee or subcommittee pursuant to paragraph (a) of this section shall be addressed to the Archivist. All requests shall be in writing and, where practicable, identify the records sought with reasonable specificity.

(c) Presidential records of a former President shall be available to the former President or his designated representative upon request.

### § 1270.46 Notice of intent to disclose Presidential records.

(a) The Archivist or his designee shall notify a former President or his designated representative(s) before any Presidential records of his Administration are disclosed.

(b)(1) The notice given by the Archivist or his designee shall:

(i) Be in writing;

(ii) Identify the particular records with reasonable specificity;

(iii) State the reason for the disclosure; and

(iv) Specify the date on which the record will be disclosed.

(2) In the case of records to be disclosed in accordance with § 1270.44, the notice shall also:

(i) Identify the requester and the nature of the request;

(ii) Specify whether the requested records contain materials to which access would otherwise be restricted pursuant to 44 U.S.C. 2204(a) and identify the category of restriction within which the record to be disclosed falls; and

(iii) Specify the date of the request.

(c) If, after receiving the notice required by paragraph (a) of this section, a former President raises rights or privileges which he believes should preclude the disclosure of a Presidential record, and the Archivist nevertheless determines that the record in question should be disclosed, in whole or in part, the Archivist shall notify the former President or his representative of this determination. The notice given by the Archivist or his designee shall:

(1) Be in writing;

(2) State the basis upon which the determination to disclose the record is made; and

(3) Specify the date on which the record will be disclosed.

(d) The Archivist shall not disclose any records covered by any notice required by paragraph (a) or (c) of this section for at least 30 calendar days from receipt of the notice by the former President, unless a shorter time period is required by a demand for Presidential records under § 1270.44.

(e) Copies of all notices provided to former Presidents under this section shall be provided at the same time to the incumbent President.

## Subpart E—Presidential Records Compiled for Law Enforcement Purposes

### § 1270.50 Consultation with law enforcement agencies.

(a) For the processing of Presidential records compiled for law enforcement purposes that may be subject to 5 U.S.C. 552(b)(7), the Archivist shall request specific guidance from the appropriate Federal agency on the proper treatment of a record if there is no general guidance applicable, if the record is particularly sensitive, or if



**National Archives and Records Administration**

**§ 1270.50**

the type of record or information is widespread throughout the files.

(b) When specific agency guidance is requested under paragraph (a) of this section, the Archivist shall notify the appropriate Federal agency of the decision regarding disclosure of the specific documents. Notice shall include the following:

(1) A description of the records in question;

(2) Statements that the records described contain information compiled

for law enforcement purposes and may be subject to the exemption provided by 5 U.S.C. 552(b)(7) for records of this type; and,

(3) The name of a contact person at NARA.

(c) Agency guidance under this section is not binding on the Archivist. The final determination on whether Presidential records may be subject to the exemption in 5 U.S.C. 552(b)(7) is the Archivist's responsibility.

## SUBCHAPTER F—NIXON PRESIDENTIAL MATERIALS

### PART 1275—PRESERVATION AND PROTECTION OF AND ACCESS TO THE PRESIDENTIAL HISTORICAL MATERIALS OF THE NIXON ADMINISTRATION

Sec.

1275.1 Scope of part.

#### Subpart A—General Provisions

- 1275.10 Purpose.
- 1275.12 Application.
- 1275.14 Legal custody.
- 1275.16 Definitions.
- 1275.18 Requests or demands for access.

#### Subpart B—Preservation and Protection

- 1275.20 Responsibility.
- 1275.22 Security.
- 1275.24 Archival processing.
- 1275.26 Access procedures.
- 1275.28 Extraordinary authority during emergencies.

#### Subpart C—Access to Materials by Former President Nixon, Federal Agencies, and for Use in Any Judicial Proceeding

- 1275.30 Access by former President Nixon.
- 1275.32 Access by Federal agencies.
- 1275.34 Access for use in judicial proceedings.

#### Subpart D—Access by the Public

- 1275.40 Scope of subpart.
- 1275.42 Processing period; notice of proposed opening.
- 1275.44 Rights and privileges; right to a fair trial.
- 1275.46 Segregation and review; Senior Archival Panel; Presidential Materials Review Board.
- 1275.48 Transfer of materials.
- 1275.50 Restriction of materials related to abuses of governmental power.
- 1275.52 Restriction of materials of general historical significance unrelated to abuses of governmental power.
- 1275.54 Periodic review of restrictions.
- 1275.56 Appeal of restrictions.
- 1275.58 Deletion of restricted portions.
- 1275.60 Requests for declassification.
- 1275.62 Reference room locations, hours, and rules.
- 1275.64 Reproduction of tape recordings of Presidential conversations.
- 1275.66 Reproduction and authentication of other materials.
- 1275.68 Amendment of regulations.

1275.70 Freedom of information requests.

APPENDIX A TO PART 1275—SETTLEMENT AGREEMENT

AUTHORITY: 44 U.S.C. 2104, 2111 note.

SOURCE: 51 FR 7230, Feb. 28, 1986, unless otherwise noted.

#### § 1275.1 Scope of part.

This part sets forth policies and procedures concerning the preservation and protection of and access to the tape recordings, papers, documents, memorandums, transcripts, and other objects and materials which constitute the Presidential historical materials of Richard M. Nixon, covering the period beginning January 20, 1969, and ending August 9, 1974.

#### Subpart A—General Provisions

##### § 1275.10 Purpose.

This part 1275 implements the provisions of title I of the Presidential Recordings and Materials Preservation Act (Pub. L. 93-526; 88 Stat. 1695). It prescribes policies and procedures by which the National Archives and Records Administration will preserve, protect, and provide access to the Presidential historical materials of the Nixon Administration.

##### § 1275.12 Application.

This part 1275 applies to all of the Presidential historical materials of the Nixon Administration in the custody of the Archivist of the United States pursuant to the provisions of title I of the Presidential Recordings and Materials Preservation Act (Pub. L. 93-526; 88 Stat. 1695).

##### § 1275.14 Legal custody.

The Archivist of the United States has or will obtain exclusive legal custody and control of all Presidential historical materials of the Nixon Administration held pursuant to the provisions of title I of the Presidential Recordings and Materials Preservation Act (Pub. L. 93-526; 88 Stat. 1695).

**§ 1275.16 Definitions.**

For the purposes of this part 1275, the following terms have the meaning ascribed to them in this § 1275.16.

(a) *Presidential historical materials.* The term *Presidential historical materials* (also referred to as *historical materials* and *materials*) shall mean all papers, correspondence, documents, pamphlets, books, photographs, films, motion pictures, sound and video recordings, machine-readable media, plats, maps, models, pictures, works of art, and other objects or materials made or received by former President Richard M. Nixon or by members of his staff in connection with his constitutional or statutory powers or duties as President and retained or appropriate for retention as evidence of or information about these powers or duties. Included in this definition are materials relating to the political activities of former President Nixon or members of his staff, but only when those activities directly relate to or have a direct effect upon the carrying out of constitutional or statutory powers or duties. Excluded from this definition are documentary materials of any type that are determined to be the official records of an agency of the Government; private or personal materials; stocks of publications, processed documents, and stationery; and extra copies of documents produced only for convenience or reference when they are clearly so identified.

(b) *Private or personal materials.* The term *private or personal materials* shall mean those papers and other documentary or commemorative materials in any physical form relating solely to a person's family or other non-governmental activities, including private political associations, and having no connection with his constitutional or statutory powers or duties as President or as a member of the President's staff.

(c) *Abuses of governmental power popularly identified under the generic term "Watergate."* The term *abuses of governmental power popularly identified under the generic term "Watergate"* (also referred to as *abuses of governmental power*), shall mean those alleged acts, whether or not corroborated by judicial, administrative or legislative proceedings, which allegedly were con-

ducted, directed or approved by Richard M. Nixon, his staff or persons associated with him in his constitutional or statutory functions as President, or as political activities directly relating to or having a direct effect upon those functions, and which—

(1) Were within the purview of the charters of the Senate Select Committee on Presidential Campaign Activities or the Watergate Special Prosecution Force; or

(2) Are circumscribed in the Articles of Impeachment adopted by the House Committee on the Judiciary and reported to the House of Representatives for consideration in House Report No. 93-1305.

(d) *General historical significance.* The term *general historical significance* shall mean having administrative, legal, research or other historical value as evidence of or information about the constitutional or statutory powers or duties of the President, which an archivist has determined is of a quality sufficient to warrant the retention by the United States of materials so designated.

(e) *Archivist.* The term *Archivist* shall mean the Archivist of the United States or his designated agent. The term *archivist* shall mean an employee of the National Archives and Records Administration who, by education or experience, is specially trained in archival science.

(f) *Agency.* The term *agency* shall mean an executive department, military department, independent regulatory or nonregulatory agency, Government corporation, Government-controlled corporation, or other establishment in the executive branch of the Government including the Executive Office of the President. For purposes of § 1275.32 only, the term *agency* shall also include the White House Office.

(g) *Archival processing.* The term *archival processing* may include the following general acts performed by archivists with respect to the Presidential historical materials: Shelving boxes of documents in chronological, alphabetical, numerical or other sequence; surveying and developing a location register and cross-index of the boxes; arranging materials; refoldering and reboxing the documents and

**§ 1275.18**

affixing labels; producing finding aids such as folder title lists, scope and content notes, biographical data, and series descriptions; rewinding, duplicating and preserving the original tape recordings; enhancing the tape recordings on which the conversations are wholly or partially unintelligible so that extraneous noises may be filtered out; producing general subject matter logs of the tape recordings; reproducing and transcribing tape recordings; reviewing the materials to identify items that appear subject to restriction; identifying items in poor physical condition and assuring their preservation; identifying materials requiring further processing; and preparation for public access of all materials which are not subject to restriction.

(h) *Staff*. The term *staff* shall mean those persons whose salaries were paid fully or partially from appropriations to the White House Office or Domestic Council, or who were detailed on a non-reimbursable basis to the White House Office or Domestic Council from any other Federal activity; or those persons who otherwise were designated as assistants to the President, in connection with their service in that capacity; or any persons whose files were sent to the White House Central Files Unit or Special Files Unit, for purposes of those files.

(i) *National security classified information*. The term *national security classified information* shall mean any matter which is security classified under existing law, and has been or should be designated as such.

[51 FR 7230, Feb. 28, 1986, as amended at 61 FR 17844, Apr. 23, 1996]

**§ 1275.18 Requests or demands for access.**

Each agency which receives a request or legal demand for access to Presidential historical materials of the Nixon Administration shall immediately forward the request or demand to the Archivist of the United States, National Archives and Records Administration (NARA), Washington, DC 20408.

**36 CFR Ch. XII (7-1-03 Edition)**

**Subpart B—Preservation and Protection**

**§ 1275.20 Responsibility.**

The Archivist is responsible for the preservation and protection of the Nixon Presidential historical materials.

[61 FR 17845, Apr. 23, 1996]

**§ 1275.22 Security.**

The Archivist is responsible for providing adequate security for the Presidential historical materials.

**§ 1275.24 Archival processing.**

When authorized by the Archivist and until the commencement of archival processing in accordance with subpart D of this part, archivists may process the Presidential historical materials to the extent necessary for protecting and preserving the materials, and for providing authorized access to the materials pursuant to subpart C of this part.

**§ 1275.26 Access procedures.**

(a) The Archivist will receive and/or prepare appropriate documentation of each access authorized under this part 1275.

(b) Entry to the records storage areas will be provided by the Archivist only to archival, maintenance, security, or other necessary personnel or to Mr. Nixon or his agent. Two persons, at least one of whom represents the Archivist, will be present at all times that records storage areas are occupied.

(c) The Archivist will determine that each individual having access to the Presidential historical materials has a security clearance equivalent to the highest degree of national security classification that may be applicable to any of the material examined.

(d) The Archivist will provide former President Nixon or his designated attorney or agent (hereinafter Mr. Nixon), prior notice of, and allow him to be present during, each search necessary to comply with an authorized access under § 1275.32 or § 1275.34.

(e) Only NARA archivists shall conduct searches necessary to comply with

authorized accesses under §§ 1275.32 and 1275.34.

(f) Prior to releasing Presidential historical materials in accordance with an access authorized under § 1275.32 or § 1275.34, the Archivist will give Mr. Nixon notice of the nature and identity of, and at his request allow him access to, those Presidential historical materials which the archivists have determined are covered by the subpoena, or other lawful process, or request. The notice will also inform Mr. Nixon that he may file a claim with the Archivist objecting to the release of all or portions of the described materials within 5 workdays of his receiving the notice described herein. The claim should detail the alleged rights and privileges of Mr. Nixon which would be violated by the release of the materials. The Archivist will refrain from releasing any of the materials to the requester during this period, and while any claim of right or privilege is pending before him, will refrain from releasing the materials subject to the claim.

(g) The Archivist will notify Mr. Nixon in writing of the administrative determination on any claims filed in accordance with paragraph (f) of this section. In the event the determination is wholly or partially adverse to the claim, the Archivist will refrain from releasing the materials to the requester for an additional 5 workdays from Mr. Nixon's receipt of the determination.

(h) Whenever possible, a copy, which shall be certified upon request, instead of the original documentary Presidential historical materials shall be provided to comply with a subpoena or other lawful process or request. Whenever the original documentary material is removed, a certified copy of the material shall be inserted in the proper file until the return of the original.

**§ 1275.28 Extraordinary authority during emergencies.**

In the event of an emergency that threatens the physical preservation of the Presidential historical materials or their environs, the Archivist will take such steps as may be necessary, including removal of the materials to temporary locations outside the metropoli-

tan area of the District of Columbia, to preserve and protect the materials.

**Subpart C—Access to Materials by Former President Nixon, Federal Agencies, and For Use in Any Judicial Proceeding**

**§ 1275.30 Access by former President Nixon.**

In accordance with the provisions of subpart B of this part, former President Richard M. Nixon or his designated agent shall at all times have access to Presidential historical materials in the custody and control of the Archivist.

**§ 1275.32 Access by Federal agencies.**

In accordance with the provisions of subpart B of this part, any Federal agency or department in the executive branch shall have access for lawful Government use to the Presidential historical materials in the custody and control of the Archivist to the extent necessary for ongoing Government business. The Archivist will only consider written requests from heads of agencies or departments, deputy heads of agencies or departments, or heads of major organizational components or functions within agencies or departments.

**§ 1275.34 Access for use in judicial proceedings.**

In accordance with the provisions of subpart B of this part, and subject to any rights, defenses, or privileges which the Federal Government or any person may invoke, the Presidential historical materials in the custody and control of the Archivist will be made available for use in any judicial proceeding and are subject to subpoena or other lawful process.

**Subpart D—Access by the Public**

**§ 1275.40 Scope of subpart.**

This subpart sets forth policies and procedures concerning public access to the Presidential historical materials of Richard M. Nixon.

**§ 1275.42 Processing period; notice of proposed opening.**

(a)(1) The archivists will conduct archival processing of those materials other than tape recordings to prepare them for public access. In processing the materials, the archivists will give priority to segregating private or personal materials and transferring them to their proprietary or commemorative owner in accordance with § 1275.48. In conducting such archival processing, the archivists will restrict portions of the materials pursuant to §§ 1275.50 and 1275.52. All materials other than tape recordings to which reference is made in § 1275.64 will be prepared for public access and released subject to restrictions or outstanding claims or petitions seeking such restrictions. The Archivist will open for public access each integral file segment of materials upon completion of archival processing of that segment.

(2) The archivists will conduct archival processing of the tape recordings to prepare them for public access in accordance with the provisions set forth in the Settlement Agreement (see Appendix A to this part). In conducting the archival processing of the tape recordings, the archivists will restrict segments of the tape recordings pursuant to §§ 1275.50 and 1275.52. The tape segments which consist of abuses of governmental power information, as defined in § 1275.16(c), will be given priority processing by the archivists and will be prepared for public access and released following review and resolution of objections from the Nixon estate and other interested parties as set forth in the Settlement Agreement (see Appendix A to this Part). After the tape segments which consist of abuses of governmental power information have been released, the archivists will conduct archival processing of those tape recordings which were taped in the Cabinet Room, as set forth in the Settlement Agreement, Appendix A to this Part. Following release of the Cabinet Room tape recordings, the remaining tape recordings will be prepared for public access and released in five segments in accordance with the schedule set forth in the Settlement Agreement. In addition, NARA will identify and return any additional private or personal

segments to the Nixon estate, at approximately the time that NARA proposes each segment for public release.

(b) At least 30 calendar days prior to the opening to public access of any integral file segment of the materials, the Archivist will publish notice in the FEDERAL REGISTER of the proposed opening. The notice will reasonably identify the material to be opened and will include a reference to the right of any interested person to file a claim or petition in accordance with § 1275.44. Copies of the notice will be sent to the incumbent President of the United States or his designated agent and by first-class mail to the last known address of: Mr. Nixon, or his designated agent or heirs; any former staff member reasonably identifiable as the individual responsible for creating or maintaining the file segment proposed to be opened; any individual named in the material which the Archivist may not restrict in accordance with § 1275.50(b) because the material is essential to an understanding of any abuse of governmental power; and any persons named in the materials who are registered with the National Archives and Records Administration in accordance with paragraph (c) of this section.

(c) The Archivist will maintain a registry which shall contain the names and mailing addresses of persons who wish to receive personal notice of the proposed opening of integral file segments of the materials when those segments contain references about them. To be included in the registry, a person must submit his/her name and mailing address to the National Archives and Records Administration (NLN), Washington, DC 20408. Both the envelope and letter should be prominently marked, "Nixon Materials Registry." By submitting his/her name for inclusion in the registry, a person agrees to reimburse the United States for the cost of first-class postage for each instance of personal notice received.

[51 FR 7230, Feb. 28, 1986, as amended at 61 FR 17845, Apr. 23, 1996]

**§ 1275.44 Rights and privileges; right to a fair trial.**

(a) Within 30 days following publication of the notice prescribed in

§ 1275.42(b), any person claiming a legal or constitutional right or privilege which would prevent or limit public access to any of the materials shall notify the Archivist in writing of the claimed right or privilege and the specific materials to which it relates. Unless the claim states that particular materials are private or personal (see paragraph (d) of this section), the Archivist will notify the claimant by certified mail, return receipt requested, of his decision regarding public access to the pertinent materials. If that decision is adverse to the claimant, the Archivist will refrain from providing public access to the pertinent materials for at least 30 calendar days from receipt by the claimant of such notice.

(b) Within 30 days following publication of the notice prescribed in § 1275.42(b), officers of any Federal, State, or local court and other persons who believe that public access to any of the materials may jeopardize an individual's right to a fair and impartial trial should petition the Archivist setting forth the relevant circumstances that warrant withholding specified materials. The Archivist will notify the petitioner by certified mail, return receipt requested, of his decision regarding public access to the pertinent materials. If that decision is adverse to the petitioner, the Archivist will refrain from providing public access to the pertinent materials for at least 30 calendar days from receipt by the petitioner of such notice.

(c) In reaching decisions required by paragraphs (a) and (b) of this section, the Archivist may consult with other appropriate Federal agencies. If these consultations require the transfer of copies of the materials to Federal officials in agencies other than the National Archives and Records Administration, the Archivist will transfer these copies in accordance with the procedures prescribed in §§ 1275.26 and 1275.32.

(d) Within 30 days following publication of notice prescribed in § 1275.42(b), any person claiming that materials proposed for public access are in fact private or personal, as defined in § 1275.16(b), and that he or she is the proprietary or commemorative owner of those materials shall notify the Ar-

chivist in writing. The claim shall describe the specific materials to which it refers, and the claimant's basis for concluding that these materials are private or personal. Upon receipt of such a claim, the Archivist will transmit it to the Presidential Materials Review Board for its consideration and determination in accordance with § 1275.46(i). The Archivist will refrain from providing public access to the pertinent materials or from returning them to the claimant for at least 30 calendar days from receipt by the claimant or any intervening parties of the Board's determination.

(e)(1) In place of the right to make all other objections with respect to the tape segments that NARA has designated as abuses of governmental power materials, the Nixon estate may object to their release only on the ground that such designation by NARA is clearly inconsistent with the term "abuses of governmental power" as used in § 104(a)(1) of the Presidential Recordings and Materials Preservation Act (PRMPA) and defined in § 1275.16(c), as qualified by § 1275.50(b). Any such objection may not be based on isolated instances of alleged failure by NARA to apply the appropriate review standard, but only on a pattern of misapplication of the requirements of the PRMPA and its implementing regulations. Further, any such objection must be accompanied by specific examples of alleged review errors and contain sufficient information to enable the review panel of three Presidential Library archivists appointed by the Archivist, as described in the Settlement Agreement, Appendix A to this Part, to locate those examples readily.

(2) If an objection is made by the Nixon estate to the abuses of governmental power tape segments, the matter shall be immediately referred to a panel of three Presidential Library archivists appointed by the Archivist as set forth in the Settlement Agreement, Appendix A to this Part. The decision of the panel shall be either that the Nixon estate's objection is sustained or that it is rejected. The decision shall include a brief statement of the panel's reasons, but it need not include an item-by-item determination. In deciding whether the designation by NARA

of the material proposed to be released is clearly inconsistent with the definition of “abuses of governmental power”, the panel shall consider whether the release would seriously injure legitimate interests of identifiable individuals, whether the errors suggest a pattern of misinterpretation, and any other factor that bears on the issue of whether NARA’s designation of material as relating to “abuses of governmental power” was reasonable, considered as a whole. The panel’s decision shall be final and binding on all parties to the *Kutler* litigation, and no party may exercise any right to appeal to any person, board, or court that might otherwise be available.

(3) The Nixon estate may, at any time, elect to use the procedures outlined in paragraphs (e)(1) and (e)(2) of this section for the tape recordings other than the abuses of governmental power segments, except that the standard under which objections shall be made by the Nixon estate, and under which the review panel shall decide their merits, is whether the release taken as a whole is plainly inconsistent with the requirements of the Presidential Recordings and Materials Preservation Act of 1974 and these regulations. If the Nixon estate elects to use the procedures in paragraph 1 of the Settlement Agreement (Appendix A to this Part) in place of the provisions in paragraphs 4 (b) and (d) and 5(c) of the Settlement Agreement for a tape segment, the estate cannot subsequently revert back to the formal objection process set forth in this section for that tape segment.

[51 FR 7230, Feb. 28, 1986; 51 FR 8671, Mar. 13, 1986, as amended at 61 FR 17845, Apr. 23, 1996]

**§ 1275.46 Segregation and review; Senior Archival Panel; Presidential Materials Review Board.**

(a) During the processing period described in §1275.42(a), the Archivist will assign archivists to segregate private or personal materials, as defined in §1275.16(b). The archivists shall have sole responsibility for the initial review and determination of private or personal materials. At all times when the archivists or other authorized officials have access to the materials in accordance with these regulations,

they shall take all reasonable steps to minimize the degree of intrusion into private or personal materials. Except as provided in these regulations, the archivists or other authorized officials shall not disclose to any person private or personal or otherwise restricted information learned as a result of their activities under these regulations.

(b) During the processing period described in §1275.42(a), the Archivist will assign archivists to segregate materials neither relating to abuses of governmental power, as defined in §1275.16(c), nor otherwise having general historical significance, as defined in §1275.16(d). The archivists shall have sole responsibility for the initial review and determination of those materials which are not related to abuses of governmental power and do not otherwise have general historical significance.

(c) During the processing period described in §1275.42(a), the Archivist will assign archivists to segregate materials subject to restriction, as prescribed in §§1275.50 and 1275.52. The archivists shall have sole responsibility for the initial review and determination of materials that should be restricted. The archivists shall insert a notification of withdrawal at the front of the file folder or container affected by the removal of restricted material. The notification shall include a brief description of the restricted material and the basis for the restriction as prescribed in §§1275.50 and 1275.52.

(d) If the archivists are unable to make a determination required in paragraphs (a), (b), or (c) of this section, or if the archivists conclude that the required determination raises significant issues involving interpretation of these regulations or will have far-reaching precedential value, the archivists shall submit the pertinent materials, or representative examples of them, to a panel of senior archivists selected by the Archivist. The Panel shall then have the sole responsibility for the initial determination required in paragraphs (a), (b), or (c) of this section.

(e) If the Senior Archival Panel is unable to make a determination required in paragraph (d) of this section, or if the panel concludes that the required



determination raises significant issues involving interpretation of these regulations or will have far-reaching precedential value, the Panel shall certify the matter and submit the pertinent materials, or representative examples of them, to the Presidential Materials Review Board.

(f) The Presidential Materials Review Board (Board) shall consist of the Archivist, who shall serve as Chairman, and the following additional members:

(1) The Assistant Archivist for the Office of the National Archives;

(2) The Assistant Archivist for the Office of the Presidential Libraries;

(3) The Director of the Legal Counsel Staff of the National Archives and Records Administration; and

(4) The Historian of a Federal agency who shall be selected by the Archivist in his capacity as Chairman.

The Board shall meet at the call of the Chairman. Three members of the Board shall constitute a quorum for the conduct of the Board's business, although each member of the Board may participate in all of the Board's decisions. Members of the Board may be represented by their delegates on those occasions when they are unable to attend the meetings of the Board. The Board may consult with officials of interested Federal agencies in formulating its decisions. To the extent these consultations require the transfer of copies of materials to Federal officials outside the National Archives and Records Administration, the Board shall comply with the requirements of §§1275.26 and 1275.32.

(g) When the matter certified to the Board by the Senior Archival Panel involves a determination required in paragraphs (a) or (b) of this section, the Board shall prepare a final written decision, together with dissenting and concurring opinions, of the proper categorization and disposition of the pertinent materials. The Board's decision will be the final administrative determination.

(h) When the matter certified to the Board by the Senior Archival Panel involves a determination required in paragraph (c) of this section, the Board shall recommend an initial determination to the Senior Archival Panel,

which shall retain the sole responsibility for the initial determination.

(i) When the Board considers a matter referred to it by the Archivist as provided in §1275.44(d), it shall follow these procedures:

(1) The Board shall notify the claimant of its consideration of the claim, and invite the claimant to supplement at his discretion the basis for the claim.

(2) The Board will publish notice in the FEDERAL REGISTER, advising the public of its consideration of the claim, and describing the materials in question as fully as reasonably possible without disclosing arguably private or personal information. The notice will further advise that any member of the public may petition the Board within 15 calendar days of the publication of notice, setting forth the intervenor's views concerning the public or private nature of the materials.

(3) The Board shall take into account the positions maintained by the claimant and any intervenors in reaching its decision. The Board shall issue its decision, including dissenting and concurring opinions, no sooner than 20 days nor later than 60 days from the publication of notice in the FEDERAL REGISTER provided in paragraph (h)(2), of this section. The Board's decision shall be the final administrative determination. The Archivist will notify the claimant and any intervenors of the Board's decision by certified mail, return receipt requested, and shall refrain from acting upon that decision for 30 calendar days as provided in §1275.44(d).

[51 FR 7230, Feb. 28, 1986, as amended at 61 FR 17845, Apr. 23, 1996]

#### § 1275.48 Transfer of materials.

(a) The Archivist will transfer sole custody and use of those materials determined to be private or personal, or to be neither related to abuses of governmental power nor otherwise of general historical significance, to former President Nixon's estate, or, when appropriate and after notifying the Nixon estate, to the former staff member having primary proprietary or commemorative interest in the materials. Such materials to be transferred include all

**§ 1275.50**

**36 CFR Ch. XII (7-1-03 Edition)**

segments of the original tape recordings that have been or will be identified as private or personal.

(b) Materials determined to be neither related to abuses of governmental power nor otherwise of general historical significance, and transferred pursuant to paragraph (a) of this section, shall upon such transfer no longer be deemed Presidential historical materials as defined in § 1275.16(a).

[51 FR 7230, Feb. 28, 1986, as amended at 61 FR 17845, Apr. 23, 1996; 64 FR 56678, Oct. 21, 1999]

**§ 1275.50 Restriction of materials related to abuses of governmental power.**

(a) The Archivist will restrict access to materials determined during the processing period to relate to abuses of governmental power, as defined in § 1275.16(c), when:

(1) The Archivist, in accordance with § 1275.44, is in the process of reviewing or has determined the validity of a claim by any person of a legal or constitutional right or privilege; or

(2) The Archivist, in accordance with § 1275.44, is in the process of reviewing or has determined the validity of a petition by any person of the need to protect an individual's right to a fair and impartial trial; or

(3) The release of the materials would violate a Federal statute; or

(4) The materials are authorized under criteria established by Executive order to be kept secret in the interest of national defense or foreign policy, provided that any question as to whether materials are in fact properly classified or are properly subject to classification shall be resolved in accordance with the applicable Executive order or as otherwise provided by law. However, the Archivist may waive this restriction when:

(i)(A) The requester is engaged in a historical research project; or

(B) The requester is a former Federal official who had been appointed by the President to a policymaking position and who seeks access only to those classified materials which he originated, reviewed, signed or received while in public office; and

(ii) The requester has a security clearance equivalent to the highest de-

gree of national security classification that may be applicable to any of the materials to be examined; and

(iii) The Archivist has determined that the heads of agencies having subject matter interest in the material do not object to the granting of access to the materials; and

(iv) The requester has signed a statement, which declares that the requester will not publish, disclose, or otherwise compromise the classified material to be examined and that the requester has been made aware of Federal criminal statutes which prohibit the compromise or disclosure of this information.

(b) The Archivist will restrict access to any portion of materials determined to relate to abuses of governmental power when the release of those portions would constitute a clearly unwarranted invasion of personal privacy or constitute libel of a living person: *Provided*, That if material related to an abuse of governmental power refers to, involves or incorporates such personal information, the Archivist will make available such personal information, or portions thereof, if such personal information, or portions thereof, is essential to an understanding of the abuses of governmental power.

**§ 1275.52 Restriction of materials of general historical significance unrelated to abuses of governmental power.**

(a) The Archivist will restrict access to materials determined during the processing period to be of general historical significance, but not related to abuses of governmental power, under one or more of the circumstances specified in § 1275.50(a).

(b) The Archivist will restrict access to materials of general historical significance, but not related to abuses of governmental power, when the release of these materials would:

(1) Disclose trade secrets and commercial or financial information obtained from a person and privileged or confidential; or

(2) Constitute a clearly unwarranted invasion of personal privacy or constitute libel of a living person; or

(3) Disclose investigatory materials compiled for law enforcement purposes,

but only when the disclosure of such records would:

- (i) Interfere with enforcement proceedings;
- (ii) Deprive a person of a right to a fair trial or an impartial adjudication;
- (iii) Constitute an unwarranted invasion of personal privacy;
- (iv) Disclose the identity of a confidential source, and in the case of a record compiled by a criminal law enforcement authority in the course of a criminal investigation or by an agency conducting a lawful national security intelligence investigation, confidential information furnished only by the confidential source;
- (v) Disclose investigative techniques and procedures; or
- (vi) Endanger the life or physical safety of law enforcement personnel.

**§ 1275.54 Periodic review of restrictions.**

The Archivist periodically will assign archivists to review materials placed under restriction by § 1275.50 or § 1275.52 and to make available for public access those materials which, with the passage of time or other circumstances, no longer require restriction. If the archivists are unable to determine whether certain materials should remain restricted, the archivists shall submit the pertinent materials, or representative examples of them, to the Senior Archival Panel described in § 1275.44(d), which shall then have the responsibility for determining if the materials should remain restricted. The Senior Archival Panel may seek the recommendations of the Presidential Materials Review Board, in the manner prescribed in paragraph (e) and (h) of § 1275.46, in making its determination. Before opening previously restricted materials, the Archivist will comply with the notice requirements of § 1275.42(b).

[51 FR 7230, Feb. 28, 1986; 51 FR 8671, Mar. 13, 1986]

**§ 1275.56 Appeal of restrictions.**

Upon petition of any researcher who claims in writing to the Archivist that the restriction of specified materials is inappropriate and should be removed, the archivists shall submit the pertinent materials, or representative ex-

amples of them, to the Presidential Materials Review Board described in § 1275.46(f). The Board shall review the restricted materials, and consult with interested Federal agencies as necessary. To the extent these consultations require the transfer of copies of materials to Federal officials outside the National Archives and Records Administration, the Board shall comply with the requirements of §§ 1275.26 and 1275.32. As necessary and practicable, the Board shall also seek the views of any person, including former President Nixon, whose rights or privileges might be adversely affected by a decision to open the materials. The Board shall prepare a final written decision, including dissenting and concurring opinions, as to the continued restriction of all or part of the pertinent materials. The Board's decision shall be the final administrative determination. The Archivist will notify the petitioner and other interested persons of the final administrative determination within 60 calendar days following receipt of such petition. If the Board's decision is to open previously restricted materials, the Archivist will comply with the notice requirements of § 1275.42(b).

[51 FR 7230, Feb. 28, 1986, as amended at 61 FR 17846, Apr. 23, 1996]

**§ 1275.58 Deletion of restricted portions.**

The Archivist will provide a requester any reasonably segregable portions of otherwise restricted materials after the deletion of the portions which are restricted under this § 1275.50 or § 1275.52.

**§ 1275.60 Requests for declassification.**

Challenges to the classification and requests for the declassification of national security classified materials shall be governed by the provisions of 36 CFR part 1254 of this chapter, as that may be amended from time to time.

**§ 1275.62 Reference room locations, hours, and rules.**

The Archivist shall, from time to time, separately prescribe the precise location or locations where the materials shall be available for public reference, and the hours of operation and

**§ 1275.64**

rules governing the conduct of researchers using such facilities. This information may be obtained by writing to: Office of Presidential Libraries (NL), The National Archives, Washington, DC 20408.

**§ 1275.64 Reproduction of tape recordings of Presidential conversations.**

(a) To ensure the preservation of original tape recordings of conversations which were recorded or caused to be recorded by any officer or employee of the Federal Government and which:

(1) Involve former President Richard M. Nixon or other individuals who, at the time of the conversation, were employed by the Federal Government; and

(2) Were recorded in the White House or in the office of the President in the Executive Office Buildings located in Washington, DC; Camp David, MD; Key Biscayne, FL; or San Clemente, CA; and

(3) Were recorded during the period beginning January 20, 1969, and ending August 9, 1974, the Archivist will produce duplicate copies of such tape recordings in his custody for public and official reference use. The original tape recordings shall not be available for public access.

(b) Since the original tape recordings may contain information which is subject to restriction in accordance with § 1275.50 or § 1275.52, the archivists shall review the tapes and delete restricted portions from copies for public and official reference use.

(c) Researchers may listen to reference copies of the tape recordings described in paragraph (a) of this section in a National Archives building in the Washington, DC area and at other reference locations established by the Archivist in accordance with § 1275.62.

(d) The reproduction for members of the public of the reference copies of the available tape recordings described in paragraph (a) of this section will be permitted as follows: Copies of tape recordings will be made available following the public release of the tape segments contemplated in § 1275.42(a). Effective as of April 20, 2001, NARA will allow members of the public to obtain copies of all tapes that have been made available to the public by that date and that subsequently become available as

**36 CFR Ch. XII (7-1-03 Edition)**

they are released. Such copying will be controlled by NARA or its designated contractor. The fees for the reproduction of the tape recordings under this section shall be those prescribed in the schedule set forth in part 1258 of this chapter.

(e) The Archivist shall produce and maintain a master preservation copy of the original tape recordings for preservation purposes. The Archivist shall ensure that the master preservation copy, like the portions of the original tape recordings retained by the Archivist, does not contain those segments of the tape recordings which have been identified as private or personal and which have been transferred to the Nixon estate in accordance with § 1275.48.

[51 FR 7230, Feb. 28, 1986, as amended at 61 FR 17846, Apr. 23, 1996; 64 FR 56678, Oct. 21, 1999; 67 FR 44766, July 5, 2002]

**§ 1275.66 Reproduction and authentication of other materials.**

(a) Copying of materials, including tape recordings described in § 1275.64, may be done by NARA, by a contractor designated by NARA, or by researchers using self-service copiers or copying equipment.

(b) The Archivist may authenticate and attest copies of materials when necessary for the purpose of the research.

(c) The fees for reproduction and authentication of materials under this section shall be those prescribed in the schedule set forth in part 1258 of this chapter or pertinent successor regulation, as that schedule is amended from time to time.

[51 FR 7230, Feb. 28, 1986, as amended at 61 FR 17846, Apr. 23, 1996; 67 FR 44766, July 5, 2002]

**§ 1275.68 Amendment of regulations.**

The Archivist may from time to time amend the regulations of this subpart D in accordance with the applicable law concerning such amendments.

**§ 1275.70 Freedom of information requests.**

(a) The Archivist will process Freedom of Information Act requests for access to only those materials within the Presidential historical materials

which are identifiable by an archivist as records of an agency as defined in §1275.16(f). The Archivist will process these requests in accordance with the Freedom of Information regulations set forth in §1254.30 of this chapter or pertinent successor regulations.

(b) In order to allow NARA archivists to devote as much time and effort as possible to the processing of materials for general public access, the Archivist will not process those Freedom of Information requests where the requester can reasonably obtain the same materials through a request directed to an agency (as defined in §1275.16(f)), unless the requester demonstrates that he or she has unsuccessfully sought access from that agency or its successor in law or function.

[51 FR 7230, Feb. 28, 1986, as amended at 61 FR 17846, Apr. 23, 1996]

#### APPENDIX A TO PART 1275—SETTLEMENT AGREEMENT

Settlement Agreement filed April 12, 1996, in *Stanley I. Kutler and Public Citizen v. John W. Carlin, Archivist of the United States, and William E. Griffin and John H. Taylor, Co-executors of Richard M. Nixon's Estate, Civil Action No. 92-0662-NHJ (D.D.C.) (Johnson, J.)*. By letter dated April 17, 2001, NARA and the Nixon estate agreed to waive paragraph 11 of this Settlement Agreement, such that the delay on public copying until January 1, 2003, of tapes not made publicly available before April 12, 1996, shall no longer apply. This change is reflected in 36 CFR 1275.64.

##### *Settlement Agreement*

This Settlement Agreement ("Agreement") is made by and entered into among plaintiffs Stanley I. Kutler and Public Citizen; defendant/cross-claim defendant John W. Carlin, in his official capacity as Archivist of the United States; and defendant-intervenors/cross-claimants John H. Taylor and William E. Griffin, co-executors of the estate of Richard M. Nixon ("the Nixon estate"), in the above-entitled action by and through the parties' undersigned attorneys.

It is hereby agreed, by and among the parties, appearing through their undersigned attorneys, that this action is partially settled on the following terms:

##### TERMS OF AGREEMENT

1(a). As soon as practicable, the National Archives and Records Administration ("the Archives") will publicly release the segments of tape recordings made during the Presidency of Richard M. Nixon ("tape re-

cordings" or "tapes") identified by the Archives as relating to "abuses of governmental power," as defined by 36 C.F.R. Part 1275, along with the corresponding portions of the tape log and any other finding aid. The date of that release, which is expected to be on or about November 15, 1996, shall be determined in the following manner.

(b). No later than April 15, 1996, the Archives shall deliver to an agent of the Nixon estate a copy of the approximately 201 hours of abuses of governmental power tape segments that it proposes to release, together with the corresponding portions of the tape log and any other finding aid, for review by the Nixon estate to determine whether it intends to object to the release. The Archives agrees to provide a period of orientation to the designated Nixon estate agent with respect to the review of the abuses of governmental power tape segments and to be available to respond to questions thereafter.

(c). In place of the right to make all other objections with respect to the tape recordings that the Archives has designated as abuses of governmental power materials, the Nixon estate agrees that it may object to their release only on the ground that such designation by the Archives is clearly inconsistent with the term "abuses of governmental power" as used in section 104(a)(1) of the Presidential Recordings and Materials Preservation Act of 1974 ("the Act"), 44 U.S.C. §2111 note, and defined in 36 C.F.R. 1275.16(c), as qualified by 36 C.F.R. 1275.50(b). Any such objection shall be in writing and may not be based on isolated instances of alleged failure by the Archives to apply the appropriate review standard, but only on a pattern of misapplication of the requirements of the Act and its implementing regulations. Further, any such objection must be accompanied by specific examples of alleged review errors and contain sufficient information to enable the review panel described in subparagraph 1(e) below to locate those examples readily. Nothing in this paragraph shall preclude the Nixon estate and the Archives from having informal discussions regarding the appropriate treatment of any of the abuses of governmental power tape segments.

(d). The Nixon estate shall have until October 1, 1996, to submit any objection in accordance with subparagraph 1(c) above. If no such objection is filed, the Archives shall proceed to issue a notice of proposed release pursuant to 36 C.F.R. 1275.42 as soon as possible, but no later than October 15, 1996.

(e). If an objection is made, the matter shall be immediately referred to a panel of the following three Presidential Library archivists: David Alsbrook, Frances Seeber, and Claudia Anderson. If any of these three persons is unable to serve, the Archivist shall appoint a substitute who is acceptable to the other parties.

(f). The panel shall have such access to the tapes as it deems necessary to make its decision. The decision of the panel shall be either that the Nixon estate's objection is sustained or that it is rejected. The decision shall include a brief statement of the panel's reasons, but it need not include an item-by-item determination. In deciding whether the designation by the Archives of the material proposed to be released is clearly inconsistent with the definition of "abuses of governmental power," the panel shall consider whether the release would seriously injure legitimate interests of identifiable individuals, whether the errors suggest a pattern of misinterpretation, and any other factor that bears on the issue of whether the Archives' designation of material as relating to abuses of governmental power was reasonable, considered as a whole. The decision of the panel shall be made within sixty (60) days of the date of the objection. However, if the panel determines that exceptional circumstances interfere with its ability to meet this deadline, the panel shall have up to an additional sixty (60) days to make its decision. The Archives shall notify the other parties of the need for an extension and briefly describe the reasons therefor. The panel's decision shall be final and binding on all parties, and no party may exercise any right to appeal to any person, board, or court that might otherwise be available. Nothing contained in this Agreement shall preclude the panel from advising the Archives of any particular processing errors that it believes may have been made, but the Archivist shall make the final determination as to whether to accept such advice.

(g). If the objection of the Nixon estate is sustained, the Archives shall re-review the tapes sufficiently to address the concerns raised by whatever aspect of the objection is sustained. At the conclusion of such re-review, the same process of review, first by the Nixon estate and then by the panel in the event of further objection, shall be repeated for those tape segments concerning the subject matter of the sustained objection prior to any release of tape recordings designated as relating to abuses of governmental power.

(h). The Nixon estate agrees to inform the Archives and plaintiffs whether it intends to file objections as soon as it has made its decision. If there is an objection by the Nixon estate and it is overruled, the FEDERAL REGISTER notice shall be published within ten (10) days of the date of the panel's decision.

(i). If, following the FEDERAL REGISTER notice, no objection by other individuals to a release is received within the time provided by law, the Archives shall release the tape recordings within ten (10) days after such time has expired. If objections are received, they shall be promptly considered by the Archives and shall be decided as soon thereafter as practical. Any materials as to which

an objection to release has been timely filed shall not be released until such objection has been resolved pursuant to 36 C.F.R. 1275.44. All materials not objected to shall be released no later than thirty (30) days after the time for objections has expired, provided that the Archives may withhold any additional conversation to which no objection has been made, pending final resolution of an objection to another conversation, if (i) such additional conversation is in close proximity on the tapes to the objected-to conversation and it would be burdensome for the Archives to separate out the releasable and objected-to portions, or (ii) the subjects of the releasable and the objected-to conversations are closely related to one another and the Archives determines that it might be misleading or might unfairly prejudice a living individual to release only one conversation. Any release under this Agreement shall include the corresponding portions of the tape log and any other finding aid.

(j). The Archives shall send to plaintiff Kutler, to arrive no later than the day that the release of the tapes occurs, a copy of the portions of the tape log and any other finding aid that correspond to the tapes being released. The Archives shall also make suitable arrangements for plaintiff Kutler to listen to such tapes on the date of their release, and/or on such other subsequent business days as plaintiff Kutler shall designate.

2(a). Although the Agreement provides that the Archives will identify and return to the Nixon estate a copy of any private or personal materials identified on the tapes, the parties have been unable to reach agreement regarding the Archivist's retention and maintenance of the original tape recordings in their entirety, including those segments deemed to be private or personal, along with a master preservation copy. The government's position is that it is complying with the Act by retaining the original tapes and a master preservation copy, including those portions containing private or personal conversations. The Nixon estate's position, with which plaintiffs agree, is that the family has statutory, constitutional, and other rights that prevent the Archives from retaining private or personal materials, on both the original tapes and all copies.

(b). The parties have agreed to litigate the issue described in subparagraph 2(a) above, including the validity of 36 C.F.R. 1275.48(a) and 1275.64(e) as proposed for amendment. The parties further agree that the Court shall retain jurisdiction of that issue, as provided in paragraph 14 below, and that the right to litigate this issue includes the right to seek review in the United States Court of Appeals for the District of Columbia Circuit and the United States Supreme Court. If there is litigation between the Nixon estate and the Archivist over the issue described in subparagraph 2(a) above, the plaintiffs shall

support the Nixon estate in any such litigation by filing a brief supporting the estate's position in District Court. The parties agree to make all reasonable efforts to expedite resolution of this issue.

(c). This Agreement and all discussions, negotiations and exchanges of information leading to it shall be entirely without prejudice to any positions the parties may take in the event of such litigation. Nothing in this Agreement, in any discussions leading to it, or in any information or materials exchanged by the parties as part of the mediation may be relied on or disclosed by any party to support or rebut the position of any party with respect to the treatment of private or personal materials on the original tapes. Nothing in this subparagraph prevents any party from expressing its understanding as to the meaning and effect of the legal position of another party.

3. The Archives will provide to the Nixon estate any additional private or personal materials at approximately the time that the Archives proposes each segment identified in paragraphs 4 and 5 below for public release. Any additional copies of that material (other than on a master preservation copy, the status of which will be determined in accordance with the resolution of the issue as described in subparagraph 2(a) above), will be destroyed by appropriate method, with appropriate means of verification.

4(a). The second group of tapes to be processed for release is the approximately 278 hours recorded in the Cabinet Room. The projected date for publishing a notice of proposed opening of tapes in that group is August 1, 1997. The Archives will make the Cabinet Room tapes proposed for release available to the Nixon estate in no fewer than four (4) segments. The process by which those tapes will be reviewed by the Nixon estate, and the objections handled by the Archives, is set forth in the following subparagraphs of this paragraph 4.

(b). The Nixon estate agrees to review each segment as it is received and promptly to call to the attention of the Archives any concerns that it may have. The Archives and the Nixon estate agree to attempt to work out their differences informally in order to minimize any objections to a proposed release. To facilitate informal consultation between the Nixon estate and the Archives concerning the tape review, the Archivist shall designate a panel member identified in subparagraph 1(e) above who will serve as a contact with the Nixon estate and assure access to information relating to Presidential libraries practices and procedures that may arise in the course of the tape review. The designated individual will be responsible for assuring that the Nixon estate has access to the appropriate person to answer its concerns. The Nixon estate may communicate with the designated individual orally or in

writing. If the Archives agrees with the Nixon estate that any portion of a segment that has been sent to the Nixon estate as a proposed release should not be released, the Archives shall assure that there is appropriate documentation to reflect that change.

(c). The Nixon estate will have a period of at least six (6) months in which to review all of the Cabinet Room tapes, beginning on the date the Archives makes the first installment of such tapes available to the estate for review (but in no event will the six (6) months begin earlier than November 15, 1996). During the review of the Cabinet Room tapes, the Nixon estate will employ an agent or agents who will spend an average of at least thirty two (32) hours a week (total) in actual review of the tapes. The Nixon estate may request from the Archives an extension of the six-month review period, which the Archives shall grant if good cause is shown.

(d). If, during its review, the Nixon estate becomes aware that there are materials proposed for release that it believes should not be heard even by individuals on the registry list, it will promptly advise the Archives of any such materials so that they can be reviewed and/or segregated by the Archives before any other individual is permitted to listen to them. The Nixon estate will cooperate with the Archives so that the required FEDERAL REGISTER notice is published as soon as possible, but in no event shall such notice be provided later than ten (10) days after the time the Nixon estate completes its review. Final objections from the Nixon estate to the release of portions of the tapes shall be filed in accordance with 36 C.F.R. Part 1275 no later than the date for filing objections by other persons. Thereafter, subject to paragraph 7 below, the provisions of subparagraphs 1(i) and 1(j) above will apply.

5(a). The remaining tapes, consisting of approximately 2338 hours, shall be processed for release in five (5) segments. Because the precise number of hours of tapes for each month cannot readily be determined, the parties have agreed to divide the releases into the segments set forth below. The Archives will begin processing (which includes, but is not limited to, tape review, preparing tapes for declassification review, tape editing and production of finding aids) each segment before processing of the preceding segment is concluded. Processing of the tapes in each segment is projected to take from about fifteen (15) to about twenty three (23) months. The approximate number of hours of tapes to be reviewed in each segment is set forth in parentheses in the following listing of the segments. The projected number of months between the completion of the Archives' processing of the immediately preceding segment and the completion of the Archives' processing of each listed segment is set forth in brackets.

1. February 1971–July 1971 (437 hours) [8 months]
2. August 1971–December 1971 (405 hours) [7 months]
3. January 1972–June 1972 (440 hours) [7 months]
4. July 1972–October 1972 (410 hours) [6 months]
5. November 1972–July 1973 (646 hours) [10 months]

(b). The time estimates in this Agreement are not enforceable as such, but the parties agree to have the Court retain jurisdiction to consider requests that it enter a binding order setting a schedule for the Archives to complete the processing of the tapes. No party may seek such an order unless that party first provides twenty (20) days' written notice to the other parties of that party's intention to seek such an order. Further, no party may seek such an order except on the ground that the Archives has unreasonably failed to meet the estimates contained herein by a substantial amount. The type of proof that will demonstrate reasonableness on the part of the Archives in this regard may include, but will not necessarily be limited to, a showing that the Archives is reasonably allocating its resources among its various programs and activities in the event that it experiences a shortage of resources, including any occasioned by court order.

(c). Portions of each segment processed by the Archives shall be provided to the Nixon estate when the processing of each month of tape recorded material is completed, unless there are a very few hours for two (2) or more months, which may then be combined into a single unit. During its review of the chronological tape segments, the Nixon estate will employ an agent or agents who will spend an average of at least thirty two (32) hours a week (total) in actual review of the tapes, forty eight (48) weeks of the year. As its review of the tapes proceeds, the Nixon estate shall provide a written report of its progress to the Archives and the plaintiffs on a bi-monthly basis. The report shall include the number of hours worked in each week, the number of hours of tapes reviewed in each week, and the Nixon estate's projected completion date for review of the segment currently under review. The provisions of subparagraphs 4(b) and 4(d) above shall apply to the review, objections, and releases with respect to the chronological tape segments, subject to paragraph 7 below.

(d). If one of the other parties to this Agreement determines that the Nixon estate's review is not being conducted diligently or in good faith, or that the estate's estimated completion date(s) of one or more segments is unreasonable, that party may petition the Archivist to establish an earlier date(s) for the completion of the review of that segment and/or of future segments. Any such date(s) established by the Archivist

shall provide the Nixon estate with a reasonable opportunity to protect and assert its interests without unduly delaying the release of the tapes, and shall be based upon consideration of the progress of the Archives' review and its scheduled completion date(s); the progress to date of the estate's review; and the time reasonably necessary to complete the estate's review and to formulate and present any objections. The Archives may also propose earlier dates for the completion of the review by the Nixon estate on the basis provided for in this subparagraph. If a proposal for an earlier date is made, the Nixon estate will have a reasonable opportunity to respond.

6. Once the Archives has completed processing the approximately 2338 hours of tapes discussed in paragraph 5 above, and has made corresponding releases, the Archives shall identify any additional copies of partial tape segments in its possession. If the Archives determines that some or all of such additional partial tape segments are duplicative of any tape recordings that it has already processed, the Archives may dispose of the duplicative tape segments, following notification to the parties, subject to paragraph 3 above. To the extent that such partial tape segments are not duplicative of the tape recordings already processed, the Archives shall promptly process such non-duplicative portions and shall treat any portions determined to be private or personal consistently with the resolution of the issue to be litigated as described in paragraph 2 above.

7(a). After completion of the procedures described in paragraph 4 above, the Cabinet Room tapes that are found to be releasable under paragraph 4 above may be released if either there has been a final decision by the district court on the issue to be litigated as described in subparagraph 2(a) above, or the release is scheduled after April 1, 1998, whichever of these two events happens sooner.

(b). After completion of the procedures described in paragraph 5 above, the tapes described in paragraph 5(a) above that are found to be releasable may be released if either there has been a final judgment by the district court, which is not subject to further review by appeal or certiorari, with regard to the issue to be litigated as described in subparagraph 2(a) above, or there has been a final decision by the United States Court of Appeals for the District of Columbia Circuit on this issue, or the release is scheduled to take place after November 1, 1999, whichever of these three events happens sooner.

(c). As used in subparagraphs 7(a) and (b) above, the term "final decision" means a decision not subject to reconsideration under Rule 59 of the Federal Rules of Civil Procedure, or Rules 35 or 40 of the Federal Rules of Appellate Procedure, respectively.



8. The Nixon estate may, at any time, elect to use the procedures in paragraph 1 above with respect to any tape segment in place of the provisions of paragraphs 4(b) and (d) and 5(c) above, with the following substitution: The standard under which objections shall be made, and under which the panel shall decide their merits, is whether the release taken as a whole is plainly inconsistent with the requirements of the Act and its implementing regulations. Provided, however, that once the Nixon estate elects to use the procedures in paragraph 1 above in place of the provisions in paragraphs 4(b) and (d) and 5(c) above, it cannot subsequently revert back to the formal objection process set forth in 36 C.F.R. Part 1275 for that tape segment.

9. Within thirty (30) days of the Court's entry of an order as described in paragraph 14 below, the Archivist shall designate a particular person who shall be responsible for responding to reasonable inquiries from the plaintiffs on the status of the releases and objections. Such designation may be changed at any time at the Archivist's discretion by a notice to plaintiffs through their counsel.

10. If the Archives appoints a Senior Archival Panel as defined in 36 C.F.R. 1275.46(d) and (e), no party to the Agreement may object to the appointment of such a panel on the ground that the suggestion to appoint such a panel was originated by an individual other than the processing archivists assigned to the Archives' Nixon Presidential Materials Staff.

11. The Archives will allow members of the public to obtain copies of publicly accessible portions of the tapes after the releases described in paragraph 5 above, are completed; provided, however, that if the releases described in paragraph 5 above are not completed by December 31, 1999, the Archives will allow members of the public to obtain copies only of the abuses of governmental power tapes, together with any other tapes publicly released as of the date of the filing of this Agreement with the Court, beginning January 1, 2000. Further provided, that if the releases described in paragraph 5 above are not completed by December 31, 2002, the Archives will, beginning January 1, 2003, allow members of the public to obtain copies of all tapes that have been made available to the public by that date and tapes that subsequently become available, as they are released.

12(a). Promptly after the Court enters the Order provided for in paragraph 14 below, plaintiff Kutler will withdraw his request under the Freedom of Information Act, 5 U.S.C. 552, for any and all tape logs and other finding aids, which is pending in *Kutler v. Carlin, et al.*, Civ. A. No. 92-0661-NHJ (D.D.C.). In all other respects, plaintiff Kutler's request in that action shall be unaffected by this Agreement.

(b). Nothing in this Agreement shall affect the processing by the Archives of any dictabelts, which are a collection of recordings of former President Nixon and other White House staff members dictating memoranda, correspondence and speech drafts, that are included in the materials that are subject to the Act.

13. Pursuant to Rule 315 of this Court, the plaintiffs and the defendant shall attempt to resolve the plaintiffs' claim for attorneys' fees and expenses and shall advise the Court no later than forty-five (45) days after this Court has entered the Order provided for in paragraph 14 below on whether they have been able to resolve the issue of attorneys' fees and expenses. If no resolution has been reached, they will, at that time, recommend a schedule to the Court to resolve such claim.

14. The parties agree to the dissolution of the preliminary injunction entered on August 9, 1993, and dismissal with prejudice of this action, including all claims and cross-claims, except for the issue to be litigated as described in subparagraph 2(a) above, and any fees and expenses claimed pursuant to paragraph 13 above, by filing the attached Joint Motion to Vacate Preliminary Injunction and to Dismiss Claims, and the attached Consent Order. The parties agree that the Court shall retain jurisdiction to: (a) consider the entry of an order in accordance with the terms of paragraph 5 above; (b) resolve the issue to be litigated as described in subparagraph 2(a) above; (c) determine any fees and expenses claimed pursuant to paragraph 13 above; and (d) for the purpose of enforcing the terms of this Agreement. The parties further agree that such jurisdiction, except with respect to the issue described in paragraph 2 above, will be retained only until the later of the implementation of paragraph 11 above or the completion of the releases called for in paragraph 5 above. Plaintiffs and the Nixon estate further agree that they will not challenge any regulations issued by the Archives which implement and are consistent with this Agreement.

15. The terms of this Agreement may not be altered except with the written consent of the parties. Nothing in this Agreement constitutes an admission of liability or wrongdoing on the part of any party.

Executed this 12th day of April, 1996.

For Plaintiffs Stanley I. Kutler and Public Citizen:

Alan B. Morrison,

(D.C. Bar No. 073114), *Public Citizen Litigation Group, 1600 20th Street NW., Washington, DC 20009, (202) 588-1000.*

For Defendant John W. Carlin:

Anne L. Weismann,

(D.C. Bar No. 298190)

Judry L. Subar,

**Pt. 1275, App. A**

*(D.C. Bar No. 347518)*

Alina S. Kofsky,

*(D.C. Bar No. 419093)*, Department of Justice,  
Federal Programs Branch, Civil Division, 901 E  
Street NW., Room 1010, Washington, DC 20530,  
*(202) 514-4523.*

For Defendant-Intervenors John H. Taylor  
and William E. Griffin:

Herbert J. Miller,

*(D.C. Bar No. 026120)*

R. Stan Mortenson,

**36 CFR Ch. XII (7-1-03 Edition)**

*(D.C. Bar No. 114678)*

Scott L. Nelson,

*(D.C. Bar No. 413548)*

Ellen Fels Berkman,

*(D.C. Bar No. 433310)*

Miller, Cassidy, Larroca & Lewin,

2555 M Street, NW., Washington, DC 20037,  
*(202) 293-6400.*

[61 FR 17846, Apr. 23, 1996, as amended at 67  
FR 44766, July 5, 2002]

## SUBCHAPTER G—NARA FACILITIES

### PART 1280—PUBLIC USE OF NARA FACILITIES

#### Subpart A—What Are the General Rules of Conduct on NARA Property?

##### General Information on Using NARA Facilities

###### Sec.

- 1280.1 What is the purpose of this part?
- 1280.2 What property is under the control of the Archivist of the United States?
- 1280.4 Can children under the age of 14 use NARA facilities?
- 1280.6 May I bring a seeing-eye dog or other assistance animal?
- 1280.8 Will my belongings be searched?
- 1280.10 Are there special rules for driving on NARA property?
- 1280.12 Is parking available?
- 1280.14 May I use the shuttle bus to travel to the National Archives at College Park or to the National Archives Building in Washington, DC?
- 1280.16 Are there additional rules posted?

##### Prohibited Activities

- 1280.18 May I bring guns or other weapons onto NARA property?
- 1280.20 What is your policy on illegal drugs and alcohol?
- 1280.22 Is gambling allowed on NARA property?
- 1280.24 Is smoking allowed on NARA property?
- 1280.26 May I pass out fliers on NARA property?
- 1280.28 Where can I eat and drink on NARA property?
- 1280.30 Are soliciting, vending, and debt collection allowed on NARA property?
- 1280.32 What other behavior is not permitted?

#### Subpart B—What Are the Rules for Filming, Photographing, or Videotaping on NARA Property?

- 1280.40 Definitions.
- 1280.42 When do the rules in this subpart apply?
- 1280.44 May I film, photograph, or videotape on NARA property for commercial purposes?
- 1280.46 What are the rules for filming, photographing, or videotaping on NARA property for personal use?
- 1280.48 How do I apply to film, photograph, or videotape on NARA property for news purposes?
- 1280.50 What will I be allowed to film, photograph, or videotape for news purposes?

- 1280.52 What are the rules for filming, photographing, or videotaping on NARA property for news purposes?

#### Subpart C—What Are the Additional Rules for Using NARA Facilities in the Washington, DC, Area?

- 1280.60 Where do I enter the National Archives Building in Washington, DC?
- 1280.62 When is the Exhibition Hall open?
- 1280.64 What entrance should I use to enter the National Archives at College Park?
- 1280.66 May I use the National Archives Library?
- 1280.68 May I use the cafeteria at the National Archives at College Park?

#### Subpart D—How Do I Request to Use Washington, DC, Area NARA Facilities for an Event?

- 1280.70 When does NARA allow other groups to use its public areas for events?
- 1280.72 What are the general rules for using NARA public areas?
- 1280.74 How do I apply to use NARA public areas in Washington, DC, area facilities?
- 1280.76 What will I have to pay to use a NARA public area for an event?
- 1280.78 How will NARA handle my request to use a lecture room, the auditorium, the Theater, or the Archivist's Reception Room?
- 1280.80 May I ask to use the Exhibition Hall?

#### Subpart E—What Additional Rules Apply for Use of Facilities in Presidential Libraries?

- 1280.90 What are the rules of conduct while visiting the Presidential libraries?
- 1280.92 When are the Presidential library museums open to the public?
- 1280.94 When do Presidential libraries allow other groups to use their public areas for events?
- 1280.96 Supplemental rules.

#### Subpart F—What Additional Rules Apply for Use of Public Areas at Regional Records Services Facilities?

- 1280.100 What are the rules of conduct at NARA regional records services facilities?
- 1280.102 When do NARA regional records services facilities allow other groups to use their public areas for events?

AUTHORITY: 44 U.S.C. 2104(a).

SOURCE: 65 FR 34978, June 1, 2000, unless otherwise noted.

### Subpart A—What Are the General Rules of Conduct on NARA Property?

#### GENERAL INFORMATION ON USING NARA FACILITIES

##### § 1280.1 What is the purpose of this part?

(a) This part tells you what rules you must follow when you use property under the control of the Archivist of the United States (the National Archives Building, the National Archives at College Park, and the Presidential libraries).

(b) When you are using other NARA facilities, the General Services Administration (GSA) regulations, Conduct on Federal Property, at 41 CFR subpart 101-20.3 apply to you. These facilities are the NARA regional records services facilities, the Washington National Records Center in Suitland, MD, and the National Personnel Records Center in St. Louis, MO. The rules in Subpart B of this part also apply to you if you wish to film, take photographs, or make videotapes. The rules in Subpart F of this part also apply to you if you wish to use the NARA-assigned conference rooms in those facilities.

(c) If you are using records in a NARA research room in a NARA facility, you must also follow the rules in 36 CFR part 1254.

##### § 1280.2 What property is under the control of the Archivist of the United States?

The following property is under the control of the Archivist of the United States and is defined as “NARA property” in this part 1280:

(a) *The National Archives Building.* Property under the control of the Archivist includes:

(1) The Pennsylvania Avenue, NW, entrance between 7th and 9th Streets including the area within the retaining walls on either side of the entrance, inclusive of the statues, and the steps and ramps leading up to the entrance of the building;

(2) On the 7th Street, 9th Street, and Constitution Avenue, NW, sides of the building, all property between the National Archives Building and the curb line of the street, including the side-

walks and other grounds, the steps leading up to the Constitution Avenue entrance, the Constitution Avenue entrance, and the portico area between the steps and the Constitution Avenue entrance.

(3) The National Park Service controls the areas on the Pennsylvania Avenue side of the National Archives Building that are not under the control of the Archivist of the United States.

(b) *The National Archives at College Park.* Property under control of the Archivist includes approximately 37 acres bounded:

(1) On the west by Adelphi Road;

(2) On the north by the Potomac Electric Power Company right-of-way;

(3) On the east by Metzert Road; and

(4) On the south by the University of Maryland.

(c) *The Presidential Libraries.* Property under control of the Archivist includes the Presidential Libraries and Museums that are listed in 36 CFR 1253.3.

##### § 1280.4 Can children under the age of 14 use NARA facilities?

Children under the age of 14 will be admitted to NARA facilities only if they are accompanied by an adult who will supervise them at all times while on NARA property. The director of a NARA facility may authorize a lower age limit for admission of unaccompanied children to meet special circumstances (e.g., students who have been given permission to conduct research without adult supervision).

##### § 1280.6 May I bring a seeing-eye dog or other assistance animal?

Yes, persons with disabilities may bring guide dogs or other animals used for guidance and assistance onto NARA property. You may not bring any other animals into a NARA facility except for official purposes.

##### § 1280.8 Will my belongings be searched?

Yes, at any time NARA may inspect all packages, briefcases, and other containers that you bring onto NARA property, including when you are entering or exiting NARA property.

**§ 1280.10 Are there special rules for driving on NARA property?**

(a) You must obey speed limits, posted signs, and other traffic laws, and park only in designated spaces.

(b) NARA will tow, at the owner's expense, any vehicle that is parked illegally. Except in emergencies, you may not park in spaces reserved for holders of NARA parking permits. If an emergency forces you to leave your vehicle in an illegal area, you must notify the security guards at that NARA facility as soon as possible. We will not tow your illegally parked car if you have notified a security guard of an emergency unless it is creating a hazard or blocking an entrance or an exit.

(c) We may deny any vehicle access to NARA property for public safety or security reasons.

**§ 1280.12 Is parking available?**

(a) *The National Archives Building.* There is no parking available for researchers or visitors to the National Archives Building. However, this building is easily accessible by bus or subway and there are several commercial parking lots located near the building.

(b) *The National Archives at College Park.* The National Archives at College Park has limited public parking space. The garage is open to the public on a first-come, first-served basis during the hours the research rooms are open. There is public bus service to this building. Individuals and groups visiting the National Archives at College Park are encouraged to use public transportation or car pool to get to the building as the parking lot is often full during our busiest hours.

(c) *Regional records services facilities.* Most regional records services facilities have onsite parking available for researchers. Parking at these facilities and at the Washington National Records Center is governed by GSA regulations, Management of Buildings and Grounds, found at 41 CFR part 101-20. The regional archives on Market Street in Philadelphia and the regional archives in New York City do not have onsite parking. However, there is ample parking in commercial parking garages near these facilities.

(d) *Presidential Libraries.* All of the Presidential Libraries have onsite

parking for researchers and museum visitors. Some of the spaces are reserved for staff and for security reasons.

**§ 1280.14 May I use the shuttle bus to travel to the National Archives at College Park or to the National Archives Building in Washington, DC?**

The NARA shuttle, which travels concurrently each hour between the National Archives Building and the National Archives at College Park, is intended for NARA employees' use for official purposes. Other Government employees on official business or researchers may also use the shuttle if space is available. The shuttle operates Monday through Friday, excluding Federal holidays, 8:00 a.m. to 5:00 p.m.

[65 FR 34978, June 1, 2000; 65 FR 35840, June 6, 2000]

**§ 1280.16 Are there additional rules posted?**

Yes, there are additional rules posted on NARA property. You must, at all times while on NARA property, comply with official NARA signs and with the directions of the guards and NARA staff.

## PROHIBITED ACTIVITIES

**§ 1280.18 May I bring guns or other weapons onto NARA property?**

No, you may not bring firearms or other dangerous or deadly weapons either openly or concealed onto NARA property except for official business. You also may not bring explosives, or items intended to be used to fabricate an explosive or incendiary device, onto NARA property. State-issued concealed-carry permits are not valid on NARA property.

**§ 1280.20 What is your policy on illegal drugs and alcohol?**

You may not use or be in possession of illegal drugs on NARA property. You also may not enter NARA property while under the influence of illegal drugs or alcohol. Using alcoholic beverages on NARA property is prohibited except for occasions when the Archivist of the United States or his/her designee has granted an exemption in writing.

**§ 1280.22**

**§ 1280.22 Is gambling allowed on NARA property?**

(a) No, you may not participate in any type of gambling while on NARA property. This includes:

- (1) Participating in games for money or other personal property;
- (2) Operating gambling devices;
- (3) Conducting a lottery or pool; or
- (4) Selling or purchasing numbers tickets.

(b) This rule does not apply to licensed blind operators of vending facilities who are selling chances for any lottery set forth in a State law and conducted by an agency of a State as authorized by section 2(a)(5) of the Randolph-Sheppard Act (20 U.S.C. 107, *et seq.*)

**§ 1280.24 Is smoking allowed on NARA property?**

Smoking is not allowed inside any NARA facility.

**§ 1280.26 May I pass out fliers on NARA property?**

No, you may not distribute or post handbills, fliers, pamphlets or other materials on bulletin boards or elsewhere on NARA property, except in those spaces designated by NARA as public forums. This prohibition does not apply to displays or notices distributed as part of authorized Government activities or bulletin boards used by employees to post personal notices.

**§ 1280.28 Where can I eat and drink on NARA property?**

You may only eat and drink in designated areas in NARA facilities. Eating and drinking is prohibited in the research, records storage, and museum areas unless specifically authorized by the Archivist or designee.

**§ 1280.30 Are soliciting, vending, and debt collection allowed on NARA property?**

- (a) No, on NARA property you may not:
- (1) Solicit for personal, charitable, or commercial causes;
  - (2) Sell any products;
  - (3) Display or distribute commercial advertising; or
  - (4) Collect private debts.

**36 CFR Ch. XII (7-1-03 Edition)**

(b) If you are a NARA employee or contractor, you may participate in national or local drives for funds for welfare, health or other purposes that are authorized by the Office of Personnel Management and/or approved by NARA (e.g. the Combined Federal Campaign). Also, nothing in this section prohibits employees from activities permitted under the Standards of Ethical Conduct and Office of Government Ethics rules.

**§ 1280.32 What other behavior is not permitted?**

We reserve the right to remove anyone from NARA property who is:

- (a) Stealing NARA property;
- (b) Willfully damaging or destroying NARA property;
- (c) Creating any hazard to persons or things;
- (d) Throwing anything from or at a NARA building;
- (e) Improperly disposing of rubbish.
- (f) Acting in a disorderly fashion;
- (g) Acting in a manner that creates a loud or unusual noise or a nuisance;
- (h) Acting in a manner that unreasonably obstructs the usual use of NARA facilities;
- (i) Acting in a manner that otherwise impedes or disrupts the performance of official duties by Government and contract employees;
- (j) Acting in a manner that prevents the general public from obtaining NARA-provided services in a timely manner; or
- (k) Loitering.

**Subpart B—What Are the Rules for Filming, Photographing, or Videotaping on NARA Property?**

**§ 1280.40 Definitions.**

- (a) *Filming, photographing, or videotaping for commercial purposes.* Any filming, photographing, or videotaping to promote commercial enterprises or commodities.
- (b) *News filming, photographing, or videotaping.* Any filming, photographing, or videotaping done by a commercial or non-profit news organization that is intended for use in a television or radio news broadcast, newspaper, or periodical.

(c) *Personal use filming, photographing, or videotaping.* Any filming, photographing, or videotaping intended solely for personal use that will not be commercially distributed.

**§ 1280.42 When do the rules in this subpart apply?**

(a) These rules apply to anyone who is filming, photographing, or videotaping inside any NARA-run facility and while on NARA property.

(b) Filming, photographing, and videotaping on the grounds of any NARA regional records services facility, or on the grounds surrounding the Washington National Records Center are governed by GSA regulations, Management of Buildings and Grounds, found at 41 CFR part 101-20, and must be approved by a GSA official.

**§ 1280.44 May I film, photograph, or videotape on NARA property for commercial purposes?**

No, filming, photographing, and videotaping on NARA property for commercial purposes is prohibited.

**§ 1280.46 What are the rules for filming, photographing, or videotaping on NARA property for personal use?**

(a) You may film, photograph, or videotape outside a NARA facility so long as you do not impede vehicular or pedestrian traffic.

(b) You may film, photograph, or videotape inside a NARA facility during regular business hours in public areas, including research rooms and exhibition areas, under the following conditions:

(1) You may not use a flash or other supplemental lighting;

(2) You may not use a tripod or similar equipment; and

(3) You may not film, photograph, or videotape while on the interior steps or ramp leading to the Declaration of Independence, the Constitution, and the Bill of Rights in the Exhibition Hall of the National Archives Building.

**§ 1280.48 How do I apply to film, photograph, or videotape on NARA property for news purposes?**

(a) If you wish to film, photograph, or videotape for news purposes at the National Archives Building, the National Archives at College Park, or the

Washington National Records Center, you must request permission from the NARA Public Affairs Officer, 8601 Adelphi Road, College Park, Maryland, 20740-6001.

(b) If you wish to film, photograph, or videotape for news purposes at a Presidential library or at a regional records services facility, you must contact the director of the library (see 36 CFR 1253.3 for contact information) or regional records services facility (see 36 CFR 1253.6 for contact information) to request permission.

(c) Your request for permission to film, photograph, or videotape for news purposes must contain the following information:

(1) The name of the organization you are working for;

(2) Areas you wish to film, photograph, or videotape;

(3) Documents, if any, you wish to film;

(4) The purpose of the project you are working on;

(5) What you intend to do with the film, photograph, or videotape; and

(6) How long you will need to complete your work on NARA property.

(d) You must request permission at least one week in advance of your desired filming date. If you make a request within a shorter time period, we may not be able to accommodate your request.

(e) OMB control number 3095-0040 has been assigned to the information collection contained in this section.

(f) This section does not apply to you if you have permission to use your own microfilming equipment to film archival records and donated historical materials under the provisions of 36 CFR 1254.90 through 1254.102. You must follow the procedures in 36 CFR part 1254 for permission to film archival records and donated materials for research purposes or for microfilm publications.

**§ 1280.50 What will I be allowed to film, photograph, or videotape for news purposes?**

(a) NARA will permit you to film, photograph, or videotape sections of the interior or exterior of any NARA facility only for stories about:

(1) NARA programs;

(2) NARA exhibits;

§ 1280.52

36 CFR Ch. XII (7-1-03 Edition)

- (3) NARA holdings;
- (4) NARA services;
- (5) A former President;
- (6) A researcher who has made or is making use of NARA holdings (provided that the researcher also approves your request); or

(7) Any other NARA-related activity approved by the appropriate NARA representative.

(b) NARA reserves the right to reject any request that does not meet the criteria set forth in 36 CFR 1280.50(a) and (c) or because of scheduling or staffing constraints.

(c) We will not grant you permission to film, photograph, or videotape if you intend to use the film, photographs, or videotape for commercial, partisan political, sectarian, or similar activities.

**§ 1280.52 What are the rules for filming, photographing, or videotaping on NARA property for news purposes?**

The following conditions and restrictions apply to anyone that has been granted permission to film, photograph, or videotape for news purposes under Subpart B:

(a) NARA may limit or prohibit use of artificial light in connection with the filming, photographing, or videotaping of documents for news purposes. You may not use any supplemental lighting devices while filming, photographing, or videotaping inside a NARA facility in the Washington, DC, area without the prior permission of the NARA Public Affairs Officer. If the Public Affairs Officer approves your use of artificial lighting in the Exhibition Hall, NARA will use facsimiles in place of the Declaration of Independence, the Constitution, and the Bill of Rights. If NARA approves your use of high intensity lighting, NARA will cover or replace with facsimiles all other exhibited documents that fall within the boundaries of such illumination. You may not use any supplemental lighting devices at the Presidential Libraries and the regional records services facilities without permission from a NARA representative at that facility.

(b) On a case-by-case basis, the Public Affairs Officer or other appropriate NARA representative may grant you permission to film, photograph, or videotape in stack areas containing unclassified records.

(c) While filming, photographing, or videotaping, you are liable for injuries to people or property that result from your activities on NARA property.

(d) At all times while on NARA property, you must conduct your activities in accordance with all applicable NARA regulations contained in this part.

(e) Your filming, photographing, or videotaping activity may not impede people who are entering or exiting any NARA facility unless otherwise authorized by the facility's director, or by the NARA Public Affairs Officer for Washington, DC, area facilities.

(f) You must be accompanied by a NARA staff member when filming, photographing, or videotaping the interior of any NARA facility.

(g) NARA will approve your request to do press interviews of NARA personnel on NARA property only when such employees are being interviewed in connection with official business. Interviews with NARA staff and researchers may take place only in areas designated by the NARA Public Affairs Officer for Washington, DC, area facilities, or by the appropriate NARA representative at other NARA facilities.

(h) You may film and photograph documents only in those areas which the NARA Public Affairs Staff designates in the National Archives Building, the National Archives at College Park, or the Washington National Records Center or in those areas designated as appropriate by the staff liaison at other NARA facilities.

(i) We will limit your film and photography sessions to two hours.

(j) You may not state or imply that NARA approves of or will sponsor:

(1) Your activities or views; or

(2) The uses to which you put images depicting any NARA facility.



**Subpart C—What Are the Additional Rules for Using NARA Facilities in the Washington, DC, Area?**

**§ 1280.60 Where do I enter the National Archives Building in Washington, DC?**

(a) To conduct research or official business, you must enter the Pennsylvania Avenue entrance of the National Archives Building.

(b) To visit the Exhibition Hall of the National Archives Building, you must enter through the Constitution Avenue entrance. However, the guards are authorized to admit through the Pennsylvania Avenue entrance and the Main Floor gates visitors who:

- (1) Are using wheelchairs or other medical appliances;
- (2) Are pushing strollers; or
- (3) Have other medical or physical conditions that preclude using the steps at the Constitution Avenue entrance.

**§ 1280.62 When is the Exhibition Hall open?**

You may enter the Exhibition Hall from 10 a.m. to 9 p.m. except during winter months (the day after Labor Day through March 31) when the Exhibition Hall closes at 5:30 p.m. The Archivist of the United States reserves the authority to close the Exhibition Hall to the public at any time for special events or other purposes. The building is closed on December 25.

**§ 1280.64 What entrance should I use to enter the National Archives at College Park?**

You may enter the National Archives at College Park facility only through the main entrance on Adelphi Road. This entrance will be open to visitors during normal business hours described in 36 CFR 1253.2. Commercial deliveries must be made at the loading dock which is accessible only from Metzert Road.

**§ 1280.66 May I use the National Archives Library?**

The National Archives Library facilities in the National Archives Building and in the National Archives at College Park are operated to meet the needs of

researchers and NARA staff members. If you are not conducting research in archival materials at NARA, NARA Library staff will refer you to public libraries and other possible sources for such published materials.

**§ 1280.68 May I use the cafeteria at the National Archives at College Park?**

Yes, the cafeteria at the National Archives at College Park is open to the public during normal business hours.

**Subpart D—How Do I Request to Use Washington, DC, Area NARA Facilities for an Event?**

**§ 1280.70 When does NARA allow other groups to use its public areas for events?**

(a) All public areas in NARA facilities are intended for official NARA functions. However, if NARA does not have an event scheduled in a particular area, we may allow the use of that area for an event sponsored by another Federal agency or private group. The event must comply with the conditions in this subpart.

(b) In the National Archives Building, you may request to use the following areas:

Area	Capacity
Theater .....	216 persons.
Archivist's reception room .....	70 to 150 persons.
Conference rooms .....	30 to 70 persons.

(c) In the National Archives at College Park, you may request to use the following areas:

Area	Capacity
Auditorium .....	332 persons.
Lecture rooms .....	30 to 70 persons (or up to 300 with all dividers removed).

**§ 1280.72 What are the general rules for using NARA public areas?**

You must adhere to the following rules when using any NARA facility for an event:

(a) Any use of NARA public areas for an event must be for the benefit of or in connection with the archival and records activities administered by NARA and must be consistent with the

## § 1280.74

public perception of NARA as a research and cultural institution as articulated in our Strategic Plan.

(b) The event must be sponsored, co-sponsored, or authorized by NARA.

(c) You are not allowed to charge an admission fee or make any indirect assessment for admission, and you may not otherwise collect money at the event unless specifically authorized by the Archivist of the United States for special not-for-profit events which are held by organizations sponsored by NARA. Commercial advertising or the sale of any items is not permitted.

(d) No areas on NARA property may be used to promote commercial enterprises or products or for partisan political, sectarian, or similar purposes.

(e) Use of NARA public areas will not be authorized for any organization or group that engages in discriminatory practices proscribed by the Civil Rights Act of 1964, as amended.

(f) You must not misrepresent your identity to the public nor conduct any activities in a misleading or fraudulent manner.

(g) You must ensure that no Government property is destroyed, displaced, or damaged during your use of NARA public areas. You must take prompt action to replace, return, restore, repair or repay NARA for any damage caused to Government property during the use of NARA facilities.

(h) Most areas are available from 8 a.m. until 9:30 p.m., Monday through Friday, and from 9:00 a.m. until 4:30 p.m. on Saturday. A NARA staff member must be present at all times when the NARA facility is in use. If the facilities and staff are available, NARA may approve requests for events that would be held before or after these hours.

(i) You must provide support people as needed to register guests, distribute approved literature, name tags, and other material; and

(j) NARA must approve any item that you plan to distribute or display at the event, and any notice or advertisement that mentions NARA, the National Archives Trust Fund Board, or incorporates any of the seals described in 36 CFR 1200.2.

## 36 CFR Ch. XII (7-1-03 Edition)

### § 1280.74 How do I apply to use NARA public areas in Washington, DC, area facilities?

(a) *How do I request to use a NARA public space for an event?* To request the use of a NARA public space in the Washington, DC, area, you must complete NA Form 16008, Application for Use of Space. OMB control number 3095-0043 has been assigned to the information collection contained in this section. Copies of the form are available from the Facilities and Materiel Management Services Division, National Archives and Records Administration, 8601 Adelphi Road, College Park, Maryland, 20740-6001. Completed forms must be sent to this address.

(b) *When do I need to submit my request?* You must submit requests for use of NARA public areas at least 30 calendar days before the proposed event is to occur.

### § 1280.76 What will I have to pay to use a NARA public area for an event?

(a) Non-Federal organizations will be required to make a contribution to the National Archives Trust Fund to maintain the public area and to cover the cost of additional cleaning, guard and other required services. NARA will determine how much your contribution will be, based upon the level of NARA-provided services for your event.

(b) Federal agencies using these spaces for official government functions must reimburse NARA only for the cost of additional cleaning, security, and other staff services.

(c) An estimate of the costs can be obtained by contacting the Facilities and Materiel Management Services Division, National Archives and Records Administration, 8601 Adelphi Road, College Park, Maryland, 20740-6001.

### § 1280.78 How will NARA handle my request to use a lecture room, the auditorium, the Theater, or the Archivist's Reception Room?

(a) When you request use of a NARA lecture room, auditorium, the Theater, or the Archivist's Reception Room, the Facilities and Materiel Management Services Division will review your request:

(1) To ensure that it meets all of the provisions in this subpart;

(2) To determine if the room you have requested is available on the date and time you have requested; and

(3) To determine the cost of the event.

(b) When the Facilities and Materiel Management Services Division has completed this review, they will notify you of their decision. They may ask for additional information before deciding whether or not to approve your event.

(c) NARA reserves the right to reject or require changes in any material, activity, or caterer you intend to use for the event.

**§ 1280.80 May I ask to use the Exhibition Hall?**

(a) The Exhibition Hall is primarily used for the public exhibition of the Charters of Freedom and other documents from NARA's holdings. NARA also uses the Exhibition Hall for activities that further its Strategic Plan. Therefore, the use of the Exhibition Hall for private events is not permitted. In rare circumstances, NARA does, upon application, permit other Federal agencies, quasi-Federal agencies, and State and local governments to use the Exhibition Hall for official functions, with NARA as a co-sponsor. Governmental groups that use the Exhibition Hall for official functions must reimburse NARA for the cost of additional cleaning, security, and other staff services.

(b) [Reserved]

**Subpart E—What Additional Rules Apply for Use of Facilities in Presidential Libraries?**

**§ 1280.90 What are the rules of conduct while visiting the Presidential libraries?**

In addition to the rules in Subpart A, when visiting the museums of the Presidential Libraries, you may be required to check all of your parcels and luggage in areas designated by Library staff.

**§ 1280.92 When are the Presidential library museums open to the public?**

(a) The hours of operation at Presidential Library museums vary. Please

contact the individual facility you wish to visit for the hours of operation. See 36 CFR 1253.3 for Presidential Library contact information. All Presidential Library museums are closed on Thanksgiving, December 25, and January 1, with the exception of the Lyndon Baines Johnson Library Museum, which is closed only on December 25.

(b) See 36 CFR 1253.3 for the operating hours of the research rooms of the Presidential Libraries.

**§ 1280.94 When do Presidential libraries allow other groups to use their public areas for events?**

(a) Although Presidential Library buildings and grounds are intended primarily for the libraries' use in carrying out their programs, you may request the use of Presidential Library facilities when the proposed activity is:

(1) Sponsored, cosponsored, or authorized by the library;

(2) Conducted to further the library's interests; and

(3) Scheduled so as not to interfere with the normal operation of the library.

(b) Your event at the library must be for the benefit of or in connection with the mission and programs of the library and must be consistent with the public perception of the library as a research and cultural institution.

(c) To request the use of a library area, you must apply in writing to the library director (see 36 CFR 1253.3 for the address) and complete NA Form 16011, Application for Use of Space in Presidential Libraries. OMB control number 3095-0024 has been assigned to the information collection contained in this section.

(d) You may not use library facilities for any activities that involve:

(1) Profit making;

(2) Commercial advertising and sales;

(3) Partisan political activities;

(4) Sectarian activities, or other similar activities; or

(5) Any use inconsistent with those authorized in this section.

(e) You may not charge admission fees, indirect assessment, or take any other kind of monetary collection at the event. NARA will charge normal admission fees to the museum if that area is used for the event.

## § 1280.96

(f) You will be assessed additional charges by the library director to reimburse the Government for expenses incurred as a result of your use of the library facility.

### § 1280.96 Supplemental rules.

Library directors may establish appropriate supplemental rules governing use of Presidential libraries and adjacent buildings and areas under NARA control.

## Subpart F—What Additional Rules Apply for Use of Public Areas of Regional Records Services Facilities?

### § 1280.100 What are the rules of conduct at NARA regional records services facilities?

While at any NARA regional records services facility, you are subject to the GSA regulations, Conduct on Federal Property (41 CFR subpart 101-20.3).

### § 1280.102 When do NARA regional records services facilities allow other groups to use their public areas for events?

(a) Although NARA regional records services facility auditoriums and other public spaces in the facility buildings and the facility grounds are intended primarily for the use of the NARA regional records services facility in carrying out its programs, you may request to use one of these areas for lectures, seminars, meetings, and similar activities when these activities are:

(1) Sponsored, cosponsored, or authorized by the NARA regional records services facility;

(2) To further NARA's interests; and

(3) Scheduled so as not to interfere with the normal operation of the NARA regional records services facility.

(b) Your event at the NARA regional records services facility must be for the benefit of or in connection with the mission and programs of NARA.

(c) You must ask permission to use a public area at a NARA regional records services facility from the director of that facility (see 36 CFR 1253.6 for a list of addresses).

(d) NARA regional records services facilities will not allow use of any

## 36 CFR Ch. XII (7-1-03 Edition)

auditoriums or other public spaces for any activities that involve:

(1) Profit making;

(2) Commercial advertising and sales;

(3) Partisan political activities;

(4) Sectarian activities, or other similar activities; or

(5) Any use inconsistent with those authorized in this section.

(e) You may not charge admission fees, indirect assessment, or take any other kind of monetary collection at the event.

(f) You will be assessed a charge by the facility director to reimburse the Government for expenses incurred as a result of the your use of the facility.

## PART 1284—EXHIBITS

Sec.

1284.1 Scope of part.

1284.20 Temporary exhibition of privately-owned material.

AUTHORITY: 44 U.S.C. 2104(a).

### § 1284.1 Scope of part.

This part sets forth policies and procedures concerning the exhibition of materials at the National Archives Building.

[55 FR 25307, June 21, 1990]

### § 1284.20 Temporary exhibition of privately-owned material.

(a) Documents, paintings, or other objects belonging to private individuals or organizations normally will not be accepted for display at the National Archives Building except as part of a NARA-produced exhibit.

(b) NARA may accept for temporary special exhibit at the National Archives Building privately-owned documents or other objects under the following conditions:

(1) The material to be displayed relates to the institutional history of the National Archives and Records Administration or its predecessor organizations, the National Archives Establishment and the National Archives and Records Service;

(2) Exhibition space is available in the building that the NARA Office of Public Programs and the Document Conservation Branch judge to be appropriate in terms of security, light level,

**National Archives and Records Administration**

**§ 1284.20**

climate control, and available exhibition cases or other necessary fixtures; and

(3) NARA has resources (such as exhibit and security staff) available to produce the special exhibit.

(c) The Assistant Archivist for Public Programs (NE), in conjunction with the NARA General Counsel when appropriate, shall review all offers to display privately-owned material and

shall negotiate the terms of exhibition for offers that can be accepted. The lender shall provide evidence of title to and authenticity of the item(s) to be displayed before any loan agreement is executed.

(d) The Assistant Archivist shall inform the offeror of NARA's decision within 60 days.

[55 FR 25307, June 21, 1990]

## SUBCHAPTER H—JFK ASSASSINATION RECORDS

### PART 1290—GUIDANCE FOR INTERPRETATION AND IMPLEMENTATION OF THE PRESIDENT JOHN F. KENNEDY ASSASSINATION RECORDS COLLECTION ACT OF 1992 (JFK ACT)

Sec.

- 1290.1 Scope of assassination record.
- 1290.2 Scope of additional records and information.
- 1290.3 Sources of assassination records and additional records and information.
- 1290.4 Types of materials included in scope of assassination record and additional records and information.
- 1290.5 Requirement that assassination records be released in their entirety.
- 1290.6 Originals and copies.
- 1290.7 Additional guidance.
- 1290.8 Implementing the JFK Act—Notice of Assassination Record Designation.

AUTHORITY: 44 U.S.C. 2107.

SOURCE: 60 FR 33349, June 28, 1995, unless otherwise noted. Redesignated at 65 FR 39550, June 27, 2000.

#### § 1290.1 Scope of assassination record.

(a) An *assassination record* includes, but is not limited to, all records, public and private, regardless of how labeled or identified, that document, describe, report on, analyze or interpret activities, persons, or events reasonably related to the assassination of President John F. Kennedy and investigations of or inquiries into the assassination.

(b) An *assassination record* further includes, without limitation:

(1) All records as defined in Section 3(2) of the JFK Act;

(2) All records collected by or segregated by all Federal, state, and local government agencies in conjunction with any investigation or analysis of or inquiry into the assassination of President Kennedy (for example, any intra-agency investigation or analysis of or inquiry into the assassination; any interagency communication regarding the assassination; any request by the House Select Committee on Assassinations to collect documents and other materials; or any inter- or intra-agency collection or segregation of documents and other materials);

(3) Other records or groups of records listed in the Notice of Assassination Record Designation, as described in § 1290.8 of this chapter.

[60 FR 33349, June 28, 1995. Redesignated at 65 FR 39550, June 27, 2000, as amended at 66 FR 18873, Apr. 12, 2001]

#### § 1290.2 Scope of additional records and information.

The term *additional records and information* includes:

(a) All documents used by government offices and agencies during their declassification review of assassination records as well as all other documents, indices, and other material (including but not limited to those that disclose cryptonyms, code names, or other identifiers that appear in assassination records) that the Assassination Records Review Board (Review Board) has a reasonable basis to believe may constitute an assassination record or would assist in the identification, evaluation or interpretation of an assassination record. The Review Board will identify in writing those records and other materials it intends to seek under this section.

(b) All training manuals, instructional materials, and guidelines created or used by the agencies in furtherance of their review of assassination records.

(c) All records, lists, and documents describing the procedure by which the agencies identified or selected assassination records for review.

(d) Organizational charts of government agencies.

(e) Records necessary and sufficient to describe the agency's:

- (1) Records policies and schedules;
- (2) Filing systems and organization;
- (3) Storage facilities and locations;
- (4) Indexing symbols, marks, codes, instructions, guidelines, methods, and procedures;
- (5) Search methods and procedures used in the performance of the agencies' duties under the JFK Act; and
- (6) Reclassification to a higher level, transfer, destruction, or other information (*e.g.*, theft) regarding the status of assassination records.

(f) Any other record that does not fall within the scope of assassination record as described in §1290.1, but which has the potential to enhance, enrich, and broaden the historical record of the assassination.

[60 FR 33349, June 28, 1995, unless otherwise noted. Redesignated at 65 FR 39550, June 27, 2000, as amended at 66 FR 18873, Apr. 12, 2001]

**§ 1290.3 Sources of assassination records and additional records and information.**

Assassination records and additional records and information may be located at, or under the control of, without limitation:

(a) Agencies, offices, and entities of the executive, legislative, and judicial branches of the Federal Government;

(b) Agencies, offices, and entities of the executive, legislative, and judicial branches of state and local governments;

(c) Record repositories and archives of Federal, state, and local governments, including presidential libraries;

(d) Record repositories and archives of universities, libraries, historical societies, and other similar organizations;

(e) Individuals who possess such records by virtue of service with a government agency, office, or entity;

(f) Persons, including individuals and corporations, who have obtained such records from sources identified in paragraphs (a) through (e) of this section;

(g) Persons, including individuals and corporations, who have themselves created or have obtained such records from sources other than those identified in paragraphs (a) through (e) of this section;

(h) Federal, state, and local courts where such records are being held under seal; or

(i) Foreign governments.

**§ 1290.4 Types of materials included in scope of assassination record and additional records and information.**

The term *record* in *assassination record* and *additional records and information* includes, for purposes of interpreting and implementing the JFK Act:

(a) Papers, maps, and other documentary material;

(b) Photographs;

(c) Motion pictures;

(d) Sound and video recordings;

(e) Machine readable information in any form; and

(f) Artifacts.

**§ 1290.5 Requirement that assassination records be released in their entirety.**

An assassination record shall be released in its entirety except for portions specifically postponed pursuant to the grounds for postponement of public disclosure of records established in §2107.6 of the JFK Act, and no portion of any assassination record shall be withheld from public disclosure solely on grounds of non-relevance unless, in the Review Board's sole discretion, release of part of a record is sufficient to comply with the intent and purposes of the JFK Act.

**§ 1290.6 Originals and copies.**

(a) For purposes of determining whether originals or copies of assassination records will be made part of the President John F. Kennedy Assassination Records Collection (JFK Assassination Records Collection) established under the JFK Act, the following shall apply:

(1) In the case of papers, maps, and other documentary materials, the Review Board may determine that record copies of government records, either the signed original, original production or a reproduction that has been treated as the official record maintained to chronicle government functions or activities, may be placed in the JFK Assassination Records Collection;

(2) In the case of other papers, maps, and other documentary material, the Review Board may determine that a true and accurate copy of a record in lieu of the original may be placed in the JFK Assassination Records Collection;

(3) In the case of photographs, the original negative, whenever available (otherwise, the earliest generation print that is a true and accurate copy), may be placed in the JFK Assassination Records Collection;

(4) In the case of motion pictures, the camera original, whenever available (otherwise, the earliest generation

## § 1290.7

print that is a true and accurate copy), may be placed in the JFK Assassination Records Collection;

(5) In the case of sound and video recordings, the original recording, whenever available (otherwise, the earliest generation copy that is a true and accurate copy), may be placed in the JFK Assassination Records Collection;

(6) In the case of machine-readable information, a true and accurate copy of the original (duplicating all information contained in the original and in a format that permits retrieval of the information), may be placed in the JFK Assassination Records Collection; and

(7) In the case of artifacts, the original objects themselves may be placed in the JFK Assassination Records Collection.

(b) To the extent records from foreign governments are included in the JFK Assassination Records Collection, copies of the original records shall be sufficient for inclusion in the collection.

(c) In cases where a copy, as defined in paragraph (a) of this section, is authorized by the Review Board to be included in the JFK Assassination Records Collection, the Review Board may require that a copy be certified if, in its discretion, it determines a certification to be necessary to ensure the integrity of the JFK Assassination Records Collection. In cases where an original, as defined in paragraph (a) of this section, is required for inclusion in the JFK Assassination Records Collection, the Review Board may, at its discretion, accept the best available copy. In such cases that records included in the JFK Assassination Records Collection, whether originals or copies, contain illegible portions, such records shall have attached thereto a certified transcription of the illegible language to the extent practicable.

(d) For purposes of implementing the JFK Act, the term *copy* means a true and accurate photocopy duplication by a means appropriate to the medium of the original record that preserves and displays the integrity of the record and the information contained in it.

(e) Nothing in this section shall be interpreted to suggest that additional copies of any assassination records contained in the JFK Assassination

## 36 CFR Ch. XII (7-1-03 Edition)

Records Collection are not also assassination records that, at the Review Board's discretion, may also be placed in the JFK Assassination Records Collection.

(f) Nothing in this section shall be interpreted to prevent or to preclude copies of any electronic assassination records from being reformatted electronically in order to conform to different hardware and/or software requirements of audiovisual or machine readable formats if such is the professional judgment of the National Archives and Records Administration.

### § 1290.7 Additional guidance.

(a) A government agency, office, or entity includes, for purposes of interpreting and implementing the JFK Act, all current, past, and former departments, agencies, offices, divisions, foreign offices, bureaus, and deliberative bodies of any Federal, state, or local government and includes all inter- or intra-agency working groups, committees, and meetings that possess or created records relating to the assassination of President John F. Kennedy.

(b) The inclusion of artifacts in the scope of the term assassination record is understood to apply solely to the JFK Assassination Records Collection and to implement fully the terms of the JFK Act and has no direct or indirect bearing on the interpretation or implementation of any other statute or regulation.

(c) Whenever artifacts are included in the JFK Assassination Records Collection, it shall be sufficient to comply with the JFK Act if the public is provided access to photographs, drawings, or similar materials depicting the artifacts. Additional display of or examination by the public of artifacts in the JFK Assassination Records Collection shall occur under the terms and conditions established by the National Archives and Records Administration to ensure their preservation and protection for posterity.

(d) The terms and, or, any, all, and the plural and singular forms of nouns shall be understood in their broadest and most inclusive sense and shall not be understood to be terms of limitation.



**National Archives and Records Administration**

**§ 1290.8**

(e) Unless the Review Board in its sole discretion directs otherwise, records that are identified with respect to a particular person shall include all records relating to that person that use or reflect the true name or any other name, pseudonym, codeword, symbol number, cryptonym, or alias used to identify that person.

(f) Unless the Review Board in its sole discretion directs otherwise, records that are identified by the Review Board with respect to a particular operation or program shall include all records, pertaining to that program by any other name, pseudonym, codeword, symbol, number, or cryptonym.

**§ 1290.8 Implementing the JFK Act—  
Notice of Assassination Record Designation.**

(a) A Notice of Assassination Record Designation (NARD) shall be the mechanism for the Review Board to announce publicly its determination that a record or group of records meets the definition of assassination records.

(b) Notice of all NARDs will be published in the FEDERAL REGISTER within 30 days of the decision to designate such records as assassination records.

(c) In determining to designate such records as assassination records, the Review Board must determine that the record or group of record will more likely than not enhance, enrich, and broaden the historical record of the assassination.

**PARTS 1291–1299 [RESERVED]**



## CHAPTER XV—OKLAHOMA CITY NATIONAL MEMORIAL TRUST

---

<i>Part</i>		<i>Page</i>
1501	General Provisions .....	855
1502-1599	[Reserved]	



## PART 1501—GENERAL PROVISIONS

AUTHORITY: 16 U.S.C. 450ss; Pub. L. 105-58, 111 Stat. 1261.

SOURCE: 65 FR 14761, Mar. 17, 2000, unless otherwise noted.

### §1501.1 Cross reference to National Park Service regulations.

As permitted by the Oklahoma City National Memorial Act, the Oklahoma City National Memorial Trust (the Trust) adopts by cross reference the provisions of the National Park Service in 36 CFR chapter I as shown in the following table. The table also indicates those parts, sections, and paragraphs that the Trust has chosen to exclude from adoption.

#### NATIONAL PARK SERVICE REGULATIONS

##### 36 CFR Chapter I

Excluding parts 3 and 6-199

##### PART 1 GENERAL PROVISIONS

###### §1.1 Purpose

###### §1.2 Applicability and Scope

###### §1.3 Penalties

Excluding paragraphs (b) and (c)

###### §1.4 Definitions

Excluding paragraph (b)

###### §1.5 Closures and public use limits

###### §1.6 Permits

###### §1.7 Public Notice

###### §1.8 Information Collection

###### §1.10 Symbolic Signs

##### PART 2 RESOURCE PROTECTION, PUBLIC USE AND RECREATION

Excluding §§2.3, 2.16, 2.19, 2.60

###### §2.1 Preservation of natural and cultural and archeological resources

###### §2.2 Wildlife Protection

Excluding paragraphs (b), (c), and (d)

###### §2.4 Weapons, traps, and nets

Excluding paragraph (a)(2)

###### §2.5 Research specimens

###### §2.10 Camping and food storage

Excluding paragraphs (b)(1), (b)(2), (b)(3), (b)(4), (b)(6), (b)(8), and (d)

###### §2.11 Picnicking

###### §2.12 Audio Disturbances

Excluding paragraph (a)(3)

###### §2.13 Fires

Excluding paragraph (c)

###### §2.14 Sanitation and refuse

Excluding paragraphs (a)(7) and (a)(9)

###### §2.15 Pets

Excluding paragraphs (b) and (e)

###### §2.17 Aircraft and air delivery

Excluding paragraph (a)(2)

###### §2.18 Snowmobiles

Excluding paragraphs (d) and (e)

###### §2.20 Skating, skateboards and similar devices

###### §2.21 Smoking

Excluding paragraph (b)

###### §2.22 Property

###### §2.23 Recreation fees

Excluding paragraph (a)

###### §2.30 Misappropriation of property and services

###### §2.31 Trespassing, tampering and vandalism

###### §2.32 Interfering with agency functions

###### §2.33 Report of injury or damage

###### §2.34 Disorderly conduct

###### §2.35 Alcoholic beverages and controlled substances

###### §2.36 Gambling

###### §2.37 Noncommercial soliciting

###### §2.38 Explosives

###### §2.50 Special events

###### §2.51 Public assemblies, meetings

###### §2.52 Sale or distribution of printed matter

###### §2.61 Residing on Federal lands

###### §2.62 Memorialization

##### PART 4 VEHICLES AND TRAFFIC SAFETY

###### §4.1 Applicability and scope

###### §4.2 State law applicable

###### §4.3 Authorized emergency vehicles

###### §4.4 Report of motor vehicle accident

###### §4.10 Travel on park roads and designated routes

Excluding paragraph (c)(3)

###### §4.11 Load, weight and size limits

###### §4.12 Traffic control devices

###### §4.13 Obstructing traffic

###### §4.14 Open container of alcoholic beverage

###### §4.15 Safety belts

###### §4.20 Right of way

###### §4.21 Speed limits

Excluding paragraphs (a)(2) and (a)(3)

###### §4.22 Unsafe operation

###### §4.23 Operating under the influence of alcohol or drugs

###### §4.30 Bicycles

###### §4.31 Hitchhiking

##### PART 5 COMMERCIAL AND PRIVATE OPERATIONS

Excluding §§5.4, 5.9, and 5.10

###### §5.1 Advertisements

###### §5.2 Alcoholic beverages; sale of intoxicants

Excluding paragraph (b)

###### §5.3 Business operations

###### §5.5 Commercial photography

###### §5.6 Commercial vehicles

###### §5.7 Construction of buildings or other facilities

###### §5.8 Discrimination in employment practices

###### §5.13 Nuisances

###### §5.14 Prospecting, mining, and mineral leasing



CHAPTER XVI—MORRIS K. UDALL  
SCHOLARSHIP AND EXCELLENCE IN  
NATIONAL ENVIRONMENTAL POLICY  
FOUNDATION

---

<i>Part</i>		<i>Page</i>
1600	Public availability of documents and records .....	859





## PART 1600—PUBLIC AVAILABILITY OF DOCUMENTS AND RECORDS

### Subpart A—Procedures for Disclosure of Records Under the Freedom of Information Act

Sec.

- 1600.1 General provisions.
- 1600.2 Public reading room.
- 1600.3 Requests for records.
- 1600.4 Timing of responses to requests.
- 1600.5 Responses to requests.
- 1600.6 Disclosure of requested records
- 1600.7 Special procedures for confidential Commercial information
- 1600.8 Appeals.
- 1600.9 Preservation of records.
- 1600.10 Fees.

### Subpart B—Protection of Privacy and Access to Individual Records Under the Privacy Act of 1974

- 1600.21 General provisions.
- 1600.22 Requests for access to records.
- 1600.23 Responsibility for responding to requests for access to records.
- 1600.24 Responses to requests for access to records.
- 1600.25 Appeals from denials of requests for access to records.
- 1600.26 Requests for amendment or correction of records.
- 1600.27 Requests for accountings of record disclosures.
- 1600.28 Preservation of records.
- 1600.29 Fees.
- 1600.30 Notice of court-ordered and emergency disclosures.

AUTHORITY: 5 U.S.C. 552, 552a, 553; 20 U.S.C. 5608(a)(3).

Subpart A is also issued under 5 U.S.C. 571-574.

SOURCE: 66 FR 15034, Mar. 15, 2001, unless otherwise noted.

### Subpart A—Procedures for Disclosure of Records Under the Freedom of Information Act

#### § 1600.1 General provisions.

(a) This subpart contains the rules that the Morris K. Udall Scholarship and Excellence in National Environmental Policy Foundation (the Foundation) follows in processing requests for records under the Freedom of Information Act (FOIA), 5 U.S.C. 552. These rules should be read together with the FOIA, which provides additional information about access to records. Re-

quests made by individuals for records about themselves under the Privacy Act of 1974, 5 U.S.C. 552a, which are processed under subpart B of this part, are processed under this subpart also. Information routinely provided to the public as part of a regular Foundation activity (for example, press releases, annual reports, informational brochures and the like) may be provided to the public without following this subpart. As a matter of policy, the Foundation makes discretionary disclosures of records or information exempt from disclosure under the FOIA whenever disclosure would not foreseeably harm an interest protected by a FOIA exemption, but this policy does not create any right enforceable in court.

(b) This subpart applies to all Foundation programs, including the U.S. Institute for Environmental Conflict Resolution (USIECR).

#### § 1600.2 Public reading room.

(a) The Foundation maintains a public reading room that contains the records that the FOIA requires to be made regularly available for public inspection and copying. An index of reading room records shall be available for inspection and copying and shall be updated at least quarterly.

(b) The public reading room is located at the offices of the Foundation, 110 S. Church Avenue, Suite 3350, Tucson, Arizona.

(c) The Foundation also makes reading room records created on or after November 1, 1996, available electronically, if possible, at the Foundation's web site (which can be found at [www.udall.gov](http://www.udall.gov)). This includes the index of the reading room records, which will indicate which records are available electronically.

#### § 1600.3 Requests for records.

(a) *How made and addressed.* You may make a request for records of the Foundation by writing to the General Counsel, Morris K. Udall Foundation, 110 South Church Avenue, Suite 3350, Tucson, Arizona 85701-1650. If you are making a request for records about yourself, see § 1600.21 for additional requirements. If you are making a request for records about another individual, either a written authorization signed by

#### § 1600.4

#### 36 CFR Ch. XVI (7-1-03 Edition)

that individual permitting disclosure of those records to you or proof that that individual is deceased (for example, a copy of a death certificate or an obituary) will help the processing of your request. For the quickest possible handling, you should mark both your request letter and the envelope "Freedom of Information Act Request."

(b) *Description of records sought.* You must describe the records that you seek in enough detail to enable Foundation personnel to locate them with a reasonable amount of effort. Whenever possible, your request should include specific information about each record sought, such as the date, title or name, author, recipient, and subject matter of the record. If the Foundation determines that your request does not reasonably describe records, it will tell you either what additional information is needed or why your request is otherwise insufficient. If your request does not reasonably describe the records you seek, the response to your request may be delayed.

(c) *Types of records not available.* The FOIA does not require the Foundation to:

(1) Compile or create records solely for the purpose of satisfying a request for records;

(2) Provide records not yet in existence, even if such records may be expected to come into existence at some future time; or

(3) Restore records destroyed or otherwise disposed of, except that the Foundation must notify the requester that the requested records have been destroyed or disposed of.

(d) *Agreement to pay fees.* If you make a FOIA request, your request shall be considered an agreement by you to pay all applicable fees charged under § 1600.10, up to \$25.00, unless you seek a waiver of fees. The Foundation ordinarily will confirm this agreement in an acknowledgment letter. When making a request, you may specify a willingness to pay a greater or lesser amount.

#### § 1600.4 Timing of responses to requests.

(a) *In general.* The Foundation ordinarily shall respond to requests according to their order of receipt.

(b) *Multitrack processing.* (1) The Foundation may use two or more processing tracks by distinguishing between simple and more complex requests based on the amount of work and/or time needed to process the request. The anticipated number of pages involved may be considered by the Foundation in establishing processing tracks. If the Foundation sets a page limit for its faster track, it will advise those whose request is placed in its slower track(s) of the page limits of its faster track(s).

(2) If the Foundation uses multitrack processing, it may provide requesters in its slower track(s) with an opportunity to limit the scope of their requests in order to qualify for faster processing within the specified limits of its faster track(s).

(c) *Unusual circumstances.* (1) Where the statutory time limits for processing a request cannot be met because of "unusual circumstances," as defined in the FOIA, and the Foundation decides to extend the time limits on that basis, the Foundation shall as soon as practicable notify the requester in writing of the unusual circumstances and of the date by which processing of the request can be expected to be completed. Where the extension is for more than 10 working days, the Foundation shall provide the requester with an opportunity either to modify the request so that it may be processed within the time limits or to arrange an alternative time period for processing the request or a modified request.

(2) Where the Foundation reasonably believes that multiple requests submitted by a requester, or by a group of requesters acting in concert, constitute a single request that would otherwise involve unusual circumstances, and the requests involve clearly related matters, they may be aggregated. Multiple requests involving unrelated matters will not be aggregated.

(d) *Expedited processing.* (1) Requests and appeals will be taken out of order and given expedited treatment whenever it is determined that they involve:

(i) Circumstances in which the lack of expedited treatment could reasonably be expected to pose an imminent threat to the life or physical safety of an individual; or

(ii) An urgency to inform the public about an actual or alleged federal government activity, if made by a person primarily engaged in disseminating information;

(2) You may ask for expedited processing of a request for records at any time.

(3) In order to request expedited processing, you must submit a statement, certified to be true and correct to the best of your knowledge and belief, explaining in detail the basis for requesting expedited processing. For example, if you are a requester within the category in paragraph (d)(1)(ii) of this section, and you are not a full-time member of the news media, you must establish that you are a person whose main professional activity or occupation is information dissemination, though it need not be your sole occupation; you also must establish a particular urgency to inform the public about the government activity involved in the request, beyond the public's right to know about government activity generally. The formality of certification may be waived as a matter of administrative discretion.

(4) Within 10 calendar days of receipt of a request for expedited processing, the Foundation will decide whether to grant it and will notify you of the decision. If a request for expedited treatment is granted, the request will be given priority and processed as soon as practicable. If a request for expedited processing is denied, any appeal of that decision will be acted on expeditiously.

#### § 1600.5 Responses to requests.

(a) *Acknowledgments of requests.* On receipt of your request, the Foundation ordinarily will send an acknowledgment letter to you, which will confirm your agreement to pay fees under § 1600.3(d) and provide an assigned request number for further reference.

(b) *Referral to another agency.* When a requester seeks records that originated in another Federal government agency, the Foundation will refer the request to the other agency for response. If the Foundation refers the request to another agency, it will notify the requester of the referral. A request for any records classified by some other

agency will be referred to that agency for response.

(c) *Grants of requests.* Ordinarily, the Foundation will have 20 business days from when your request is received to determine whether to grant or deny your request. Once the Foundation determines to grant a request in whole or in part, it will notify you in writing. The Foundation will inform you in the notice of any fee charged under § 1600.10 and will disclose records to you promptly on payment of any applicable fee. Records disclosed in part will be marked or annotated to show the amount of information deleted, unless doing so would harm an interest protected by an applicable exemption. The location of the information deleted also will be indicated on the record, if technically feasible.

(d) *Adverse determinations of requests.* If the Foundation denies your request in any respect, it will notify you of that determination in writing. Adverse determinations, or denials of requests, consist of: a determination to withhold any requested record in whole or in part; a determination that a requested record does not exist or cannot be located; a determination that a record is not readily reproducible in the form or format sought; a determination that what has been requested is not a record subject to the FOIA; a determination on any disputed fee matter, including a denial of a request for a fee waiver; and a denial of a request for expedited treatment. The denial letter shall be signed by the General Counsel or his/her designee, and shall include:

(1) The name and title or position of the person responsible for the denial;

(2) A brief statement of the reason(s) for the denial, including any FOIA exemption applied by the component in denying the request;

(3) An estimate of the volume of records or information withheld, in number of pages or in some other reasonable form of estimation. This estimate does not need to be provided if the volume is otherwise indicated through deletions on records disclosed in part, or if providing an estimate would harm an interest protected by an applicable exemption; and

## § 1600.6

## 36 CFR Ch. XVI (7-1-03 Edition)

(4) A statement that the denial may be appealed under § 1600.8(a) and a description of the requirements for appeal.

### § 1600.6 Disclosure of requested records.

(a) The Foundation shall make requested records available to the public to the greatest extent possible in keeping with the FOIA, except that the following records are exempt from the disclosure requirements:

(1) Records specifically authorized under criteria established by an Executive order to be kept secret in the interest of national defense or foreign policy and which are, in fact, properly classified pursuant to such Executive order;

(2) Records related solely to the internal personnel rules and practices of the Foundation;

(3) Records specifically exempted from disclosure by statute (other than 5 U.S.C. 552(b)), provided that such statute requires that the matters be withheld from the public in such a manner as to leave no discretion on the issue or that the statute establishes particular criteria for withholding information or refers to particular types of matters to be withheld. An example that applies to the Foundation is the confidentiality protection for dispute resolution communications provided by the Administrative Dispute Resolution Act of 1996 (ADRA, 5 U.S.C. 571-574).

(4) Records containing trade secrets and commercial or financial information obtained from a person and privileged or confidential;

(5) Interagency or intra-agency memoranda or letters which would not be available by law to a party other than an agency in litigation with the Foundation;

(6) Personnel and medical files and similar files the disclosure of which would constitute a clearly unwarranted invasion of personal privacy;

(7) Records or information compiled for law enforcement purposes, but only to the extent that the production of such law enforcement records or information:

(i) could reasonably be expected to interfere with enforcement proceedings;

(ii) would deprive a person of a right to a fair trial or an impartial adjudication;

(iii) could reasonably be expected to constitute an unwarranted invasion of personal privacy;

(iv) could reasonably be expected to disclose the identity of a confidential source, including a State, local or foreign agency or authority or any private institution which furnished information on a confidential basis, and in the case of a recorded or information compiled by criminal law enforcement authority in the course of a criminal investigation or by an agency conducting a lawful national security intelligence investigation, information furnished by a confidential source;

(v) would disclose techniques and procedures for law enforcement investigations or prosecutions, or would disclose guidelines for law enforcement investigations or prosecutions if such disclosure could reasonably be expected to risk circumvention of the law; or

(vi) could reasonably be expected to endanger the life or physical safety of any individual.

(8) Records contained in or related to examination, operating, or condition reports prepared by, or on behalf of, or for the use of an agency responsible for the regulation or supervision of financial institutions;

(9) Geological or geophysical information and data, including maps, concerning wells.

(b) If a requested record contains exempted material along with non-exempted material, all reasonable segregable nonexempt material shall be disclosed.

(c) Even if an exemption described in paragraph (a) of this section may be reasonably applicable to a requested record, or portion thereof, the Foundation may elect under the circumstances of any particular request not to apply the exemption to such requested record, or portion thereof, subject to the provisions in § 1600.7 for confidential commercial information. The fact that the exemption is not applied by the Foundation to any requested

record, or portion thereof, has no precedential significance as to the application or non-application of the exemption to any other requested record, or portion thereof, no matter when the request is received.

**§1600.7 Special procedures for confidential commercial information.**

(a) *Definitions.* For purposes of this section:

(1) *Business submitter* means any person or entity which provides confidential commercial information, directly or indirectly, to the Foundation and who has a proprietary interest in the information.

(2) *Commercial-use requester* means requesters seeking information for a use or purpose that furthers the commercial, trade, or profit interests of the requester or the person on whose behalf the request is made. In determining whether a requester properly belongs in this category, the Foundation shall determine, whenever reasonably possible, the use to which a requester will put the documents requested. Where the Foundation has reasonable cause to doubt the use to which a requester will put the records sought, or where that use is not clear from the request itself, the Foundation shall seek additional clarification before assigning the request to a specific category.

(3) *Confidential commercial information* means records provided to the government by a submitter that arguably contain material exempt from disclosure under Exemption 4 of the FOIA, because disclosure could reasonably be expected to cause substantial competitive harm.

(b) *In general.* Confidential commercial information provided to the Foundation by a business submitter shall not be disclosed pursuant to an FOIA request except in accordance with this section.

(c) *Designation of business information.* Business submitters should use good-faith efforts to designate, by appropriate markings, either at the time of submission or at a reasonable time thereafter, those portions of their submissions which they deem to be protected under Exemption 4 of the FOIA, 5 U.S.C. 552(b)(4). Any such designation will expire 10 years after the records

were submitted to the government, unless the submitter requests, and provides reasonable justification for, a designation period of longer duration.

(d) *Predisclosure notification.* (1) Except as is provided for in paragraph (i) of this section, the Foundation shall, to the extent permitted by law, provide a submitter with prompt written notice of an FOIA request or administrative appeal encompassing its confidential business information whenever required under paragraph (e) of this section. Such notice shall either describe the exact nature of the business information requested or provide copies of the records or portions thereof containing the business information.

(2) Whenever the Foundation provides a business submitter with the notice set forth in paragraph (e)(1) of this section, the Foundation shall notify the requester that the request includes information that may arguably be exempt from disclosure under Exemption 4 of the FOIA and that the person or entity who submitted the information to the Foundation has been given the opportunity to comment on the proposed disclosure of information.

(e) *When notice is required.* The Foundation shall provide a business submitter with notice of a request whenever—

(1) The business submitter has in good faith designated the information as business information deemed protected from disclosure under 5 U.S.C. 552(b)(4); or

(2) The Foundation has reason to believe that the request seeks business information the disclosure of which may result in substantial commercial or financial injury to the business submitter.

(f) *Opportunity to object to disclosure.* Through the notice described in paragraph (d) of this section, the Foundation shall, to the extent permitted by law, afford a business submitter at least 10 working days within which it can provide the Foundation with a detailed written statement of any objection to disclosure. Such statement shall demonstrate why the information is contended to be a trade secret or commercial or financial information that is privileged or confidential and

## § 1600.8

why disclosure would cause competitive harm. Whenever possible, the business submitter's claim of confidentiality should be supported by a statement or certification by an officer or authorized representative of the business submitter. Information provided by a submitter pursuant to this paragraph may itself be subject to disclosure under the FOIA.

(g) *Notice of intent to disclose.* (1) The Foundation shall consider carefully a business submitter's objections and specific grounds for nondisclosure prior to determining whether to disclose confidential commercial business information. Whenever the Foundation decides to disclose such information over the objection of a business submitter, the Foundation shall forward to the business submitter a written notice at least 10 working days before the date of disclosure containing—

(i) A statement of the reasons for which the business submitter's disclosure objections were not sustained,

(ii) A description of the confidential commercial information to be disclosed, and

(iii) A specified disclosure date.

(2) Such notice of intent to disclose likewise shall be forwarded to the requester at least 10 working days prior to the specified disclosure date.

(h) *Notice of FOIA lawsuit.* Whenever a requester brings suit seeking to compel disclosure of confidential commercial information, the Foundation shall promptly notify the business submitter of such action.

(i) *Exceptions to predisclosure notification.* The requirements of this section shall not apply if—

(1) The Foundation determines that the information should not be disclosed;

(2) The information lawfully has been published or has been officially made available to the public;

(3) Disclosure of the information is required by law (other than 5 U.S.C. 552); or

(4) The designation made by the submitter in accordance with paragraph (c) of this section appears obviously frivolous; except that, in such a case, the Foundation will provide the submitter with written notice of any final decision to disclose confidential com-

## 36 CFR Ch. XVI (7-1-03 Edition)

mercial information within a reasonable number of days prior to a specified disclosure date.

### § 1600.8 Appeals.

(a) *Appeals of adverse determinations.* If you are dissatisfied with the Foundation's response to your request, you may appeal an adverse determination denying your request, in any respect, to the Executive Director of the Foundation, 110 S. Church Avenue, Suite 3350, Tucson, AZ 85701-1650. You must make your appeal in writing, and it must be received by the Executive Director within 60 days of the date of the letter denying your request. Your appeal letter may include as much or as little related information as you wish, as long as it clearly identifies the determination (including the assigned request number, if known) that you are appealing. For the quickest possible handling, you should mark your appeal letter and the envelope "Freedom of Information Act Appeal."

(b) *Responses to appeals.* The decision on your appeal will be made in writing. A decision affirming an adverse determination in whole or in part shall contain a statement of the reason(s) for the affirmance, including any FOIA exemption(s) applied, and will inform you of the FOIA provisions for court review of the decision. If the adverse determination is reversed or modified on appeal, in whole or in part, you will be notified in a written decision and your request will be reprocessed in accordance with that appeal decision.

(c) *When appeal is required.* If you wish to seek review by a court of any adverse determination, you must first appeal it under this section.

### § 1600.9 Preservation of records.

The Foundation will preserve all correspondence pertaining to the requests that it receives under this subpart, as well as copies of all requested records, until disposition or destruction is authorized by title 44 of the United States Code or the National Archives and Records Administration's General Records Schedule 14. Records will not be disposed of while they are the subject of a pending request, appeal, or lawsuit under the FOIA.

**§ 1600.10 Fees.**

(a) *In general.* The Foundation will charge you for processing requests under the FOIA in accordance with paragraph (c) of this section, except where fees are limited under paragraph (d) of this section or where a waiver or reduction of fees is granted under paragraph (i) of this section. The Foundation ordinarily will collect all applicable fees before sending copies of requested records to you. You must pay fees by check or money order made payable to the United States Treasury.

(b) *Definitions.* For purposes of this section:

(1) *Commercial use request* means a request from or on behalf of a person seeking information for a use or purpose that furthers his or her commercial, trade, or profit interests, which can include furthering those interests through litigation. If the Foundation determines that you will put the records to a commercial use, either because of the nature of your request itself or because the Foundation has reasonable cause to doubt your stated use, the Foundation will provide you a reasonable opportunity to submit further clarification.

(2) *Direct costs* means those expenses that the Foundation actually incurs in searching for and duplicating (and, in the case of commercial use requests, reviewing) records to respond to a FOIA request. Direct costs include, for example, the salary of the employee performing the work and the cost of operating duplication machinery.

(3) *Duplication* means the process of making a copy of a record, or the information contained in it, available in response to a FOIA request. Copies can take the form of paper, microfilm, audiovisual materials, or electronic records (for example, magnetic tape or disk), among others. The Foundation will honor your specified preference of form or format of disclosure if the record is readily reproducible with reasonable efforts in the requested form or format.

(4) *Educational institution* means a preschool, a public or private elementary or secondary school, an institution of undergraduate or graduate higher education, an institution of professional education, and an institution

of vocational education, which operates a program or programs of scholarly research.

(5) *Noncommercial scientific institution* means an institution that is not operated on a "commercial" basis, as that term is defined in paragraph (b)(1) of this section, and that is operated solely for the purpose of conducting scientific research, the results of which are not intended to promote any particular product or industry. To be in this category, a requester must show that the request is authorized by and is made under the auspices of a qualifying institution and that the records are not sought for a commercial use but are sought to further scientific research.

(6) *Representative of the news media, or news media requester,* means any person actively gathering news for an entity that is organized and operated to publish or broadcast news to the public. The term *news* means information that is about current events or that would be of current interest to the public. Examples of news media entities include television or radio stations broadcasting to the public at large and publishers of periodicals (but only in those instances where they can qualify as disseminators of *news*) who make their products available for purchase or subscription by the general public. For *freelance* journalists to be regarded as working for a news organization, they must demonstrate a solid basis for expecting publication through that organization. A publication contract would be the clearest proof, but the Foundation shall also look to the past publication record of a requester in making this determination. To be in this category, a requester must not be seeking the requested records for a commercial use. However, a request for records supporting the news-dissemination function of the requester shall not be considered to be for a commercial use.

(7) *Review* means the examination of a record located in response to a request in order to determine whether any portion of it is exempt from disclosure. It also includes processing any record for disclosure—for example, doing all that is necessary to redact it and prepare it for disclosure. Review costs are recoverable even if a record ultimately is not disclosed. Review

time does not include time spent resolving general legal or policy issues regarding the application of exemptions.

(8) *Search* means the process of looking for and retrieving records or information responsive to a request. It includes page-by-page or line-by-line identification of information within records and also includes reasonable efforts to locate and retrieve information from records maintained in electronic form or format.

(c) *Fees*. In responding to FOIA requests, the Foundation will charge the following fees unless a waiver or reduction of fees has been granted under paragraph (i) of this section:

(1) *Search*. Search fees will be charged for all requests, except for those by educational institutions, noncommercial scientific institutions, or representatives of the news media (subject to the limitations of paragraph (d) of this section). Charges may be made for time spent searching even if no responsive record is located or if the record(s) are withheld as entirely exempt from disclosure.

(2) *Duplication*. Duplication fees will be charged for all requests, subject to the limitations of paragraph (d) of this section. For a paper photocopy of a record, the fee will be ten cents per page. For other forms of duplication (including copies produced by computer, such as tapes or printouts), the Foundation will charge the direct costs, including operator time, of producing the copy.

(3) *Review*. Review fees will be charged only for commercial use requests. Review fees will be charged only for the initial record review—in other words, the review done when the Foundation determines whether an exemption applies to a particular record or record portion at the initial request level. No charge will be made for review at the administrative appeal level for an exemption already applied. However, records or record portions withheld under an exemption that is subsequently determined not to apply may be reviewed again to determine whether any other exemption not previously considered applies; the costs of that review are chargeable where it is made

necessary by such a change of circumstances.

(4) *Searches and reviews—amounts of fees*. (i) For each quarter hour spent in searching for and/or reviewing a requested record, the fees will be: \$4.00 for clerical personnel; \$7.00 for professional personnel; and \$10.25 for managerial personnel.

(ii) For computer searches of records, you will be charged the direct costs of conducting the search, although certain requesters (as provided in paragraph (d)(1) of this section) will be charged no search fee and certain other requesters (as provided in paragraph (d)(4) of this section) will be entitled to the cost equivalent of two hours of manual search time without charge. These direct costs will include the cost of operating a central processing unit for that portion of operating time that is directly attributable to searching for responsive records, as well as the costs of operator/programmer salary apportionable to the search.

(d) *Limitations on charging fees*. (1) No search fee will be charged for requests by educational institutions, noncommercial scientific institutions, or representatives of the news media.

(2) Review fees will be charged only for commercial use requests.

(3) No search fee or review fee will be charged for a quarter-hour period unless more than half of that period is required for search or review.

(4) Except for commercial use requests, the Foundation will provide the first 100 pages of duplication and the first two hours of search time to requesters without charge. These provisions work together, so that the Foundation will not begin to assess fees until after providing the free search and reproduction. For example, if a request involves three hours of search time and duplication of 105 pages of documents, the Foundation will charge only for the cost of one hour of search time and five pages of reproduction.

(5) Whenever a total fee calculated under paragraph (d) of this section is \$14.00 or less for any request, no fee will be charged.

(e) *Notice of anticipated fees in excess of \$25.00*. When the Foundation determines or estimates that the fees will be more than \$25.00, it will notify you of



the actual or estimated amount of the fees, unless you have indicated a willingness to pay fees as high as those anticipated. If only a portion of the fee can be estimated readily, the Foundation will advise you that the estimated fee may be only a portion of the total fee. In cases in which you have been notified that actual or estimated fees amount to more than \$25.00, the request will not be considered received and further work will not be done on it until you agree in writing to pay the anticipated total fee. A notice under this paragraph will offer you an opportunity to discuss the matter with Foundation personnel in order to reformulate the request to meet your needs at a lower cost.

(f) *Charging interest.* The Foundation may charge interest on any unpaid bill starting on the 31st day following the date of billing. Interest charges will be assessed at the rate provided in 31 U.S.C. 3717 and will accrue from the date of the billing until payment is received by the Foundation.

(g) *Aggregating requests.* Where the Foundation reasonably believes that a requester or a group of requesters acting together is attempting to divide a request into a series of requests for the purpose of avoiding fees, it may aggregate those requests and charge accordingly. The Foundation may presume that multiple requests of this type made within a 30-day period have been made in order to avoid fees. Where requests are separated by a longer period, they will be aggregated only if there exists a solid basis for determining that aggregation is warranted under all the circumstances involved. Multiple requests involving unrelated matters will not be aggregated.

(h) *Advance payments.* (1) No advance payment (that is, payment before work is begun on a request) will ordinarily be required, except as described in paragraphs (h)(2) and (3) of this section. Payment owed for work already completed (that is, a prepayment before copies are sent to you) is not considered an advance payment.

(2) Where the Foundation determines or estimates that a total fee to be charged under this section will be more than \$250.00, it may require you to make an advance payment of an

amount up to the amount of the entire anticipated fee before beginning to process the request, except where it receives satisfactory assurance of full payment from you and you have a history of prompt payment.

(3) If you have previously failed to pay a properly charged FOIA fee within 30 days of the date of billing, the Foundation may require you to pay the full amount due, plus any applicable interest, and to make an advance payment of the full amount of any anticipated fee, before it begins to process a new request or continues to process a pending request from you.

(4) In cases in which the Foundation requires advance payment or payment due under paragraph (h)(2) or (3) of this section, the request shall not be considered received and further work will not be done on it until the required payment is received.

(i) *Requirements for waiver or reduction of fees.* (1) Records responsive to a request will be furnished without charge or at a charge reduced below that established under paragraph (c) of this section where the Foundation determines, based on all available information, that the requester has demonstrated that:

(i) Disclosure of the requested information is in the public interest because it is likely to contribute significantly to public understanding of the operations or activities of the government, and

(ii) Disclosure of the information is not primarily in the commercial interest of the requester.

(2) Where only some of the records to be released satisfy the requirements for a waiver of fees, a waiver will be granted for those records.

(3) If you request a waiver or reduction of fees, your request should address the factors listed in paragraph (i)(1) of this section.

### **Subpart B—Protection of Privacy and Access to Individual Records Under the Privacy Act of 1974**

#### **§ 1600.21 General provisions.**

(a) *Purpose and scope.* This subpart contains the rules that the Morris K. Udall Scholarship and Excellence in

National Environmental Policy Foundation (the "Foundation") follows under the Privacy Act of 1974, 5 U.S.C. 552a. These rules should be read together with the Privacy Act, which provides additional information about records maintained on individuals. The rules in this subpart apply to all records in systems of records maintained by the Foundation that are retrieved by an individual's name or personal identifier. They describe the procedures by which individuals may request access to records about themselves, request amendment or correction of those records, and request an accounting of disclosures of those records by the Foundation. In addition, the Foundation processes all Privacy Act requests for access to records under the Freedom of Information Act (FOIA), 5 U.S.C. 552, following the rules contained in subpart A of this part, which gives requests the benefit of both statutes.

(b) *Applicability.* This subpart applies to all Foundation programs, including the U.S. Institute for Environmental Conflict Resolution (USIECR).

(c) *Definitions.* As used in this subpart:

(1) *Request for access to a record means a request made under Privacy Act subsection (d)(1).*

(2) *Request for amendment or correction of a record means a request made under Privacy Act subsection (d)(2).*

(3) *Request for an accounting means a request made under Privacy Act subsection (c)(3).*

(4) *Requester means an individual who makes a request for access, a request for amendment or correction, or a request for an accounting under the Privacy Act.*

**§ 1600.22 Requests for access to records.**

(a) *How made and addressed.* You may make a request for access to a Foundation record about yourself by appearing in person or by writing to the Foundation. Your request should be sent or delivered to the Foundation's General Counsel, at 110 S. Church Avenue, Suite 3350, Tucson, AZ 85701-1650. For the quickest possible handling, you should mark both your request letter

and the envelope "Privacy Act Request."

(b) *Description of records sought.* You must describe the records that you want in enough detail to enable Foundation personnel to locate the system of records containing them with a reasonable amount of effort. Whenever possible, your request should describe the records sought, the time periods in which you believe they were compiled, and the name or identifying number of each system of records in which you believe they are kept. The Foundation publishes notices in the FEDERAL REGISTER that describe its systems of records. A description of the Foundation's systems of records also may be found as part of the "Privacy Act Compilation" published by the National Archives and Records Administration's Office of the Federal Register. This compilation is available in most large reference and university libraries. This compilation also can be accessed electronically at the Government Printing Office's World Wide Web site (which can be found at [http://www.access.gpo.gov/su\\_docs](http://www.access.gpo.gov/su_docs)).

(c) *Agreement to pay fees.* If you make a Privacy Act request for access to records, it shall be considered an agreement by you to pay all applicable fees charged under § 1600.29 up to \$25.00. The Foundation ordinarily will confirm this agreement in an acknowledgment letter. When making a request, you may specify a willingness to pay a greater or lesser amount.

(d) *Verification of identity.* When you make a request for access to records about yourself, you must verify your identity. You must state your full name, current address, and date and place of birth. You must sign your request and your signature must either be notarized or submitted by you under 28 U.S.C. 1746, a law that permits statements to be made under penalty of perjury as a substitute for notarization. In order to help the identification and location of requested records, you may also, at your option, include your social security number.

(e) *Verification of guardianship.* When making a request as the parent or guardian of a minor or as the guardian of someone determined by a court to be incompetent, for access to records

about that individual, you must establish:

(1) The identity of the individual who is the subject of the record, by stating the name, current address, date and place of birth, and, at your option, the social security number of the individual;

(2) Your own identity, as required in paragraph (d) of this section;

(3) That you are the parent or guardian of that individual, which you may prove by providing a copy of the individual's birth certificate showing your parentage or by providing a court order establishing your guardianship; and (4) That you are acting on behalf of that individual in making the request.

**§ 1600.23 Responsibility for responding to requests for access to records.**

(a) *In general.* In determining which records are responsive to a request, the Foundation ordinarily will include only those records in its possession as of the date the Foundation begins its search for them. If any other date is used, the Foundation will inform the requester of that date.

(b) *Authority to grant or deny requests.* The Foundation's General Counsel, or his/her designee, is authorized to grant or deny any request for access to a record of the Foundation.

(c) *Consultations and referrals.* When the Foundation receives a request for access to a record in its possession, it will determine whether another agency of the Federal Government is better able to determine whether the record is exempt from access under the Privacy Act. If the Foundation determines that it is best able to process the record in response to the request, then it will do so. If the Foundation determines that it is not best able to process the record, then it will either:

(1) Respond to the request regarding that record, after consulting with the agency best able to determine whether the record is exempt from access and with any other agency that has a substantial interest in it; or (2) Refer the responsibility for responding to the request regarding that record to another agency that originated the record (but only if that agency is subject to the Privacy Act). Ordinarily, the agency that originated a record will be pre-

sumed to be best able to determine whether it is exempt from access.

(d) *Notice of referral.* Whenever the Foundation refers all or any part of the responsibility for responding to your request to another agency, it ordinarily will notify you of the referral and inform you of the name of each agency to which the request has been referred and of the part of the request that has been referred.

(e) *Timing of responses to consultations and referrals.* All consultations and referrals shall be handled according to the date the Privacy Act access request was initially received by the Foundation, not any later date.

**§ 1600.24 Responses to requests for access to records.**

(a) *Acknowledgments of requests.* On receipt of your request, the Foundation ordinarily will send an acknowledgment letter, which shall confirm your agreement to pay fees under § 1600.22(c) and may provide an assigned request number for further reference.

(b) *Grants of requests for access.* Once the Foundation makes a determination to grant your request for access in whole or in part, it will notify you in writing. The Foundation will inform you in the notice of any fee charged under § 1600.29 and will disclose records to you promptly on payment of any applicable fee. If your request is made in person, the Foundation may disclose records to you directly, in a manner not unreasonably disruptive of its operations, on payment of any applicable fee and with a written record made of the grant of the request. If you are accompanied by another person when you make a request in person, you shall be required to authorize in writing any discussion of the records in the presence of the other person.

(c) *Adverse determinations of requests for access.* If the Foundation makes an adverse determination denying your request for access in any respect, it will notify you of that determination in writing. Adverse determinations, or denials of requests, consist of: a determination to withhold any requested record in whole or in part; a determination that a requested record does not exist or cannot be located; a determination that what has been requested

## § 1600.25

is not a record subject to the Privacy Act; a determination on any disputed fee matter; and a denial of a request for expedited treatment. The notification letter shall be signed by the General Counsel, or his/her designee, and shall include:

- (1) The name and title or position of the person responsible for the denial;
- (2) A brief statement of the reason(s) for the denial, including any Privacy Act exemption(s) applied by the Foundation in denying the request; and
- (3) A statement that the denial may be appealed under § 1600.25(a) and a description of the requirements of § 1600.25(a).

### § 1600.25 Appeals from denials of requests for access to records.

(a) *Appeals.* If you are dissatisfied with the Foundation's response to your request for access to records, you may appeal an adverse determination denying your request in any respect to the Executive Director of the Foundation, 110 S. Church Avenue, Suite 3350, Tucson, AZ 85701-1650. You must make your appeal in writing, and it must be received within 60 days of the date of the letter denying your request. Your appeal letter may include as much or as little related information as you wish, as long as it clearly identifies the determination (including the assigned request number, if any) that you are appealing. For the quickest possible handling, you should mark both your appeal letter and the envelope "Privacy Act Appeal."

(b) *Responses to appeals.* The decision on your appeal will be made in writing. A decision affirming an adverse determination in whole or in part will include a brief statement of the reason(s) for the affirmance, including any Privacy Act exemption applied, and will inform you of the Privacy Act provisions for court review of the decision. If the adverse determination is reversed or modified on appeal in whole or in part, you will be notified in a written decision and your request will be reprocessed in accordance with that appeal decision.

(c) *When appeal is required.* If you wish to seek review by a court of any adverse determination or denial of a

## 36 CFR Ch. XVI (7-1-03 Edition)

request, you must first appeal it under this section.

### § 1600.26 Requests for amendment or correction of records.

(a) *How made and addressed.* You may make a request for amendment or correction of a Foundation record about yourself by following the procedures in § 1600.22. Your request should identify each particular record in question, state the amendment or correction that you want, and state why you believe that the record is not accurate, relevant, timely, or complete. You may submit any documentation that you think would be helpful.

(b) *Foundation responses.* Within 10 working days of receiving your request for amendment or correction of records, the Foundation will send you a written acknowledgment of its receipt of your request, and it will promptly notify you whether your request is granted or denied. If the Foundation grants your request in whole or in part, it will describe the amendment or correction made and advise you of your right to obtain a copy of the corrected or amended record. If the Foundation denies your request in whole or in part, it will send you a letter stating:

- (1) The reason(s) for the denial; and
- (2) The procedure for appeal of the denial under paragraph (c) of this section, including the name and business address of the official who will act on your appeal.

(c) *Appeals.* You may appeal a denial of a request for amendment or correction to the Executive Director in the same manner as a denial of a request for access to records (see § 1600.25), and the same procedures will be followed. If your appeal is denied, you will be advised of your right to file a Statement of Disagreement as described in paragraph (d) of this section and of your right under the Privacy Act for court review of the decision.

(d) *Statements of Disagreement.* If your appeal under this section is denied in whole or in part, you have the right to file a Statement of Disagreement that states your reason(s) for disagreeing with the Foundation's denial of your request for amendment or correction. Statements of Disagreement must be concise, must clearly identify each

part of any record that is disputed, and should be no longer than one typed page for each fact disputed. Your Statement of Disagreement must be sent to the Foundation, which will place it in the system of records in which the disputed record is maintained and will mark the disputed record to indicate that a Statement of Disagreement has been filed and where in the system of records it may be found.

(e) *Notification of amendment/correction or disagreement.* Within 30 working days of the amendment or correction of a record, the Foundation shall notify all persons, organizations, or agencies to which it previously disclosed the record, if an accounting of that disclosure was made, that the record has been amended or corrected. If an individual has filed a Statement of Disagreement, the Foundation will attach a copy of it to the disputed record whenever the record is disclosed and may also attach a concise statement of its reason(s) for denying the request to amend or correct the record.

**§ 1600.27 Requests for an accounting of record disclosures.**

(a) *How made and addressed.* Except where accountings of disclosures are not required to be kept (as stated in paragraph (b) of this section), you may make a request for an accounting of any disclosure that has been made by the Foundation to another person, organization, or agency of any record about you. This accounting contains the date, nature, and purpose of each disclosure, as well as the name and address of the person, organization, or

agency to which the disclosure was made. Your request for an accounting should identify each particular record in question and should be made by writing to the Foundation, following the procedures in § 1600.22.

(b) *Where accountings are not required.* The Foundation is not required to provide accountings to you where they relate to disclosures for which accountings are not required to be kept—in other words, disclosures that are made to employees within the agency and disclosures that are made under the FOIA.

(c) *Appeals.* You may appeal a denial of a request for an accounting to the Foundation Executive Director in the same manner as a denial of a request for access to records (see § 1600.25) and the same procedures will be followed.

**§ 1600.28 Preservation of records.**

The Foundation will preserve all correspondence pertaining to the requests that it receives under this subpart, as well as copies of all requested records, until disposition or destruction is authorized by title 44 of the United States Code or the National Archives and Records Administration's General Records Schedule 14. Records will not be disposed of while they are the subject of a pending request, appeal, or lawsuit under the Act.

**§ 1600.29 Fees.**

The Foundation will charge fees for duplication of records under the Privacy Act in the same way in which it charges duplication fees under § 1600.10. No search or review fee will be charged for any record.

**§ 1600.30**

**36 CFR Ch. XVI (7-1-03 Edition)**

**§ 1600.30 Notice of court-ordered and emergency disclosures.**

(a) *Court-ordered disclosures.* When a record pertaining to an individual is required to be disclosed by a court order, the Foundation will make reasonable efforts to provide notice of this to the individual. Notice will be given within a reasonable time after the Foundation's receipt of the order—except that in a case in which the order is not a matter of public record, the notice will be given only after the order becomes public. This notice will be mailed to the individual's last known address and

will contain a copy of the order and a description of the information disclosed.

(b) *Emergency disclosures.* Upon disclosing a record pertaining to an individual made under compelling circumstances affecting health or safety, the Foundation will notify that individual of the disclosure. This notice will be mailed to the individual's last known address and will state the nature of the information disclosed; the person, organization, or agency to which it was disclosed; the date of disclosure; and the compelling circumstances justifying the disclosure.

## FINDING AIDS

---

A list of CFR titles, subtitles, chapters, subchapters and parts and an alphabetical list of agencies publishing in the CFR are included in the CFR Index and Finding Aids volume to the Code of Federal Regulations which is published separately and revised annually.

Material Approved for Incorporation by Reference  
Table of CFR Titles and Chapters  
Alphabetical List of Agencies Appearing in the CFR  
List of CFR Sections Affected





## Material Approved for Incorporation by Reference

(Revised as of July 1, 2003)

The Director of the Federal Register has approved under 5 U.S.C. 552(a) and 1 CFR Part 51 the incorporation by reference of the following publications. This list contains only those incorporations by reference effective as of the revision date of this volume. Incorporations by reference found within a regulation are effective upon the effective date of that regulation. For more information on incorporation by reference, see the preliminary pages of this volume.

### 36 CFR (300 TO END)

#### ARCHITECTURAL BARRIERS AND COMPLIANCE BOARD

#### 36 CFR

##### American National Standards Institute (ANSI)

25 West 43rd Street, Fourth floor, New York, NY 10036; Telephone:  
(212) 642-4900

- |  |   |
|--|---|
| ANSI A117.1—1986 Providing Accessibility and Usability for Physically Handicapped People.  | 1190.31; 1190.32;<br>1190.33; 1190.40           |
| ANSI IT2.19—1990, American National Standard for Photography—Density Measurements—Geometric Conditions for Transmission Density.                         | 1230.3; 1230.14                                 |
| ANSI/NAPM IT9.1—1992, American National Standard for Imaging Media (Film)—Silver-Gelatin Type—Specifications for Stability.                              | 1230.3; 1230.4;<br>1230.12; 1230.14;<br>1232.30 |
| ANSI IT9.2—1991, American National Standard for Imaging Media—Photographic Processed Films, Plates, and Papers—Filing Enclosures and Storage Containers. | 1230.3; 1230.12;<br>1230.20; 1232.26            |
| ANSI IT9.11—1991, American National Standard for Imaging Media—Processed Safety Photographic Film—Storage.   | 1230.3; 1230.20;<br>1232.26                     |
| ANSI/ISO 5/3—1984, ANSI PH2.18—1985, Photography (Sensitometry)—Density Measurements—Spectral Conditions.  | 1230.3(b)                                       |
| ANSI/ISO 543—1990 (ANSI IT9.6—1991) Photography—Photographic Films—Specifications for Safety Film.   | 1232.30   |
| ANSI/NISO/ISO 9660—1990, American National Standard for Volume and File Structure of CD-ROM for Information Exchange.                                    | 1228.270  |
| ISO 3334—1989, Micrographics—ISO resolution test chart No. 2—Description and use.  | 1230.3(b)                                       |
| ISO/IEC 15307: Information Technology—Data Interchange on 12,7 mm 128-track Magnetic Tape Cartridges—DLT 4 Format, First edition, December 1, 1997.      | 1228.270  |
| ISO/IEC 15896: Information Technology—Data Interchange on 12,7 mm 208-track Magnetic Tape Cartridges—DLT 5 Format, First edition, December 15, 1999.     | 1228.270  |
| ISO/IEC 16382: Information Technology—Data Interchange on 12,7 mm 208-track Magnetic Tape Cartridges—DLT 6 Format, First edition, May 15, 2000.          | 1228.270  |
| ANSI X3.39—1986 American National Standard: Recorded Magnetic Tape for Information Interchange (1600 CPI, PE).   | 1228.270  |

## Title 36—Parks, Forests, and Public Property

36 CFR (300 TO END)—Continued

ARCHITECTURAL BARRIERS AND COMPLIANCE BOARD—Continued

36 CFR

- ANSI X3.54–1986 American National Standard: Recorded Magnetic Tape for Information Interchange (6250 CPI, Group Coded Recording). 1228.270
- ANSI X3.180–1990, American National Standard: Magnetic Tape and Cartridge for Information Interchange - 18-Track, Parallel, 1/2 inch (12.65mm), 37 871 CPI (1491 cpmm), Group-Coded-Requirements for Recording. 1228.270
- American Society for Testing and Materials**  
100 Barr Harbor Drive, West Conshohocken, PA 19428–2929
- ASTM E 119–98, Standard Test Methods for Fire Tests of Building Construction and Materials. 1228.224(b)
- ASTM F 1292–99, Standard Specification for Impact Attenuation of Surface Systems Under and Around Playground Equipment. Part 1191, Appendix A, sections 2.3.2 and 15.6.7.2
- ASTM F 1487–98, Standard Consumer Safety Performance Specification for Playground Equipment for Public Use. Part 1191, Appendix A, sections 2.3.2 and 3.5
- ASTM F 1951–99, Standard Specification for Determination of Accessibility of Surface Systems Under and Around Playground Equipment. Part 1191, Appendix A, sections 2.3.2 and 15.6.7.1
- Association for Information and Image Management (AIIM)**  
1100 Wayne Avenue, Suite 1100, Silver Spring, MD 20910
- ANSI/AIIM MS1–1996, Standard Recommended Practice for Alpha-numeric Computer-Output Microforms—Operational Practices for Inspection and Quality Control. 1230.3(c)
- ANSI/AIIM MS5–1992, Standard for Information and Image Management—Microfiche. 1230.3(c)
- ANSI/AIIM MS14–1996, Standard Recommended Practice—Specifications for 16mm and 35mm Roll Microfilm. 1230.3(c)
- ANSI/AIIM MS19–1993, Standard Recommended Practice—Identification of Microforms. 1230.3(c)
- ANSI/AIIM MS23–1998, Standard Recommended Practice—Production, Inspection, and Quality Assurance of First-Generation, Silver Microfilm of Documents. 1230.3(c)
- ANSI/AIIM MS32–1996, Standard Recommended Practice—Microrecording of Engineering Source Documents on 35mm Microfilm. 1230.3(c)
- ANSI/AIIM MS41–1996, Dimensions of Unitized Microfilm Carriers and Apertures (Aperture, Camera, Copy, and Image Cards). 1230.3(c)
- ANSI/AIIM MS43–1998, Standard Recommended Practice—Operational Procedures—Inspection and Quality Control of Duplicate Microforms of Documents and From COM. 1230.3(c)
- ANSI/AIIM MS45–1990, Recommended Practice for Inspection of Stored Silver-Gelatin Microforms for Evidence of Deterioration. 1230.3(c)
- ANSI/ISO 5.2-1991, ANSI/NAPM IT2.19-1994, American National Standard for Photography—Density Measurement—Part 2: Geometric Conditions for Transmission Density. 1230.3(b)
- ANSI/ISO 5-3-1995, ANSI/NAPM IT2.18-1996, American National Standard for Photography—Density Measurements—Part 3: Spectral Conditions. 1230.3(b)
- ANSI/ISO 3334–1991, ANSI/AIIM MS51–1991, Micrographics—ISO Resolution Test Chart No. 2—Description and Use. 1230.3; 1230.14
- ANSI/NAPM IT9.18–1996, Imaging Materials—Processed Photographic Plates—Storage. 1228.224(f)

## Material Approved for Incorporation by Reference

**36 CFR (300 TO END)—Continued**

**ARCHITECTURAL BARRIERS AND COMPLIANCE BOARD—Continued**

**36 CFR**

ANSI/NAPM IT9.20–1996, Imaging Materials—Reflection Prints— Storage Practices.	1228.224(f)
ANSI/NAPM IT9.23–1996, Imaging Materials—Polyester Based Mag- netic Tape—Storage.	1228.224(f)
ANSI/PIMA IT9.2–1998, American National Standard for Imaging Materials—Photographic Processed Films, Plates, and Papers—Fil- ing Enclosures and Storage Containers.	1230.3(b)
ANSI/PIMA IT9.11–1998, Imaging Materials—Processed safety Photo- graphic Films—Storage.	1228.224(f)
ANSI/PIMA IT9.25–1998, Imaging Materials—Optical Disc Media— Storage.	1228.224(f)

**American Society of Heating, Refrigerating, and Air Conditioning Engineers, Inc. (ASHRAE)**

Customer Service, 1791 Tullie Circle NE, Atlanta, GA 30329

ANSI/ASHRAE 55–1992, Thermal Environmental Conditions for Human Occupancy.	1228.224(e)
ANSI/ASHRAE 62–1989, Ventilation for Acceptable Indoor Air Qual- ity.	1228.224(e)

**International Code Council (ICC)**

5203 Leesburg Pike, Suite 600, Falls Church, VA 22041-3401

International Building Code, 2000 edition .....	Section 1191, Appendix A, Section 2.3.2.2; Section 1191, Appendix A, Section 15.3.3.2
---	--

**International Organization for Standardization**

c/o American National Standards Institute (ANSI), 25 West 43rd  
Street, Fourth floor, New York, NY 10036

ISO 10602:1995(E), Photography—Processed Silver-Gelatin Type Black-and-White Film—Specifications for Stability.	1230.3(b)
ISO 18911:2000(E), Imaging Materials—Processed Safety Photographic Films—Storage Practices.	1230.3(b)

**National Fire Protection Association**

1 Batterymarch Park, Quincy, MA 02269–9101, Telephone: (800)  
344–3555

NFPA 10, Standard for Portable Fire Extinguishers (1994 Edition)	1228.224(c)
NFPA 13, Standard for the Installation of Sprinkler Systems (1996 Edition).	1228.224(c)
NFPA 20, Standard for the Installation of Centrifugal Fire Pumps (1996 Edition).	1228.224(c)
NFPA 40–1994 Standard for the Storage and Handling of Cellulose Nitrate Motion Picture Film.	1232.22
NFPA 40, Standard for the Storage and Handling of Cellulose Nitrate Motion Picture Film (1997 Edition).	1228.224(c)
NFPA 42, Code for the Storage of Pyroxylin Plastic (1997 Edition)	1228.224(c)
NFPA 72, National Fire Alarm Code (1996 Edition) .....	1228.224(c)
NFPA 101, Life Safety Code (1997 Edition) .....	1228.224(c)
NFPA 221, Standard for Fire Walls and Fire Barrier Walls .....	1228.224(c)
NFPA 231, Standard for General Storage (1998 Edition) .....	1228.224(c)
NFPA 231C, Standard for Rack Storage of Materials (1998 Edition)	1228.224(c)
NFPA 232, Standard for the Protection of Records (1995 Edition)	1228.224(c)

## Title 36—Parks, Forests, and Public Property

**36 CFR (300 TO END)—Continued**

**ARCHITECTURAL BARRIERS AND COMPLIANCE BOARD—Continued**

**36 CFR**

NFPA 232A—1995 Guide for Fire Protection for Archives and Records Centers. 1228.224(c); 1232.26

**National Information Standards Organization (NISO)**

Press Fulfillment, P.O. Box 451, Annapolis Junction, MD 20701

ANSI/NISO/ISO 9660—1990, American National Standard for Volume and File Structure of CD-ROM for Information Exchange. 1228.270

**National Institute of Standards and Technology (formerly the National Bureau of Standards)**

Office of Standard Reference Materials, Rm. B311 Chemistry, Gaithersburg, MD 20899

NBS—SRM 1010a, Microcopy Resolution Test Chart (ISO Test Chart No. 2), certified June 1, 1990. 1230.3(d)

**Underwriters Laboratory (UL)**

Available from: Global Engineering Documents, 15 Inverness Way East, Englewood, CO 80112

UL 611, Central-Station Burgular-Alarm Systems (February 22, 1996) 1228.224(d)

UL 827, Central-Station Alarm Services (April 23, 1999) ..... 1228.224(d)

UL 1076, Proprietary Burgular Alarm Units and Systems (February 1, 1999). 1228.224(d)

**U.S. Department of Commerce**

National Technical Information Service, 5285 Port Royal Rd., Springfield, VA 22161; Telephone: (703) 487-4650, FAX: (703) 487-4142

Federal Information Processing Standards Publication 173-1, Spatial Data Transfer Standard (SDTS), June 10, 1994. 1228.270

## **Table of CFR Titles and Chapters**

(Revised as of July 1, 2003)

### **Title 1—General Provisions**

- I Administrative Committee of the Federal Register (Parts 1—49)
- II Office of the Federal Register (Parts 50—299)
- IV Miscellaneous Agencies (Parts 400—500)

### **Title 2 [Reserved]**

### **Title 3—The President**

- I Executive Office of the President (Parts 100—199)

### **Title 4—Accounts**

- I General Accounting Office (Parts 1—99)

### **Title 5—Administrative Personnel**

- I Office of Personnel Management (Parts 1—1199)
- II Merit Systems Protection Board (Parts 1200—1299)
- III Office of Management and Budget (Parts 1300—1399)
- V The International Organizations Employees Loyalty Board (Parts 1500—1599)
- VI Federal Retirement Thrift Investment Board (Parts 1600—1699)
- VIII Office of Special Counsel (Parts 1800—1899)
- IX Appalachian Regional Commission (Parts 1900—1999)
- XI Armed Forces Retirement Home (Part 2100)
- XIV Federal Labor Relations Authority, General Counsel of the Federal Labor Relations Authority and Federal Service Impasses Panel (Parts 2400—2499)
- XV Office of Administration, Executive Office of the President (Parts 2500—2599)
- XVI Office of Government Ethics (Parts 2600—2699)
- XXI Department of the Treasury (Parts 3100—3199)
- XXII Federal Deposit Insurance Corporation (Part 3201)
- XXIII Department of Energy (Part 3301)
- XXIV Federal Energy Regulatory Commission (Part 3401)
- XXV Department of the Interior (Part 3501)
- XXVI Department of Defense (Part 3601)

## **Title 5—Administrative Personnel—Continued**

Chap.	
XXVIII	Department of Justice (Part 3801)
XXIX	Federal Communications Commission (Parts 3900—3999)
XXX	Farm Credit System Insurance Corporation (Parts 4000—4099)
XXXI	Farm Credit Administration (Parts 4100—4199)
XXXIII	Overseas Private Investment Corporation (Part 4301)
XXXV	Office of Personnel Management (Part 4501)
XL	Interstate Commerce Commission (Part 5001)
XLI	Commodity Futures Trading Commission (Part 5101)
XLII	Department of Labor (Part 5201)
XLIII	National Science Foundation (Part 5301)
XLV	Department of Health and Human Services (Part 5501)
XLVI	Postal Rate Commission (Part 5601)
XLVII	Federal Trade Commission (Part 5701)
XLVIII	Nuclear Regulatory Commission (Part 5801)
L	Department of Transportation (Part 6001)
LII	Export-Import Bank of the United States (Part 6201)
LIII	Department of Education (Parts 6300—6399)
LIV	Environmental Protection Agency (Part 6401)
LVI	General Services Administration (Part 6701)
LVIII	Board of Governors of the Federal Reserve System (Part 6801)
LIX	National Aeronautics and Space Administration (Part 6901)
LX	United States Postal Service (Part 7001)
LXI	National Labor Relations Board (Part 7101)
LXII	Equal Employment Opportunity Commission (Part 7201)
LXIII	Inter-American Foundation (Part 7301)
LXV	Department of Housing and Urban Development (Part 7501)
LXVI	National Archives and Records Administration (Part 7601)
LXVII	Institute of Museum and Library Services (Part 7701)
LXIX	Tennessee Valley Authority (Part 7901)
LXXI	Consumer Product Safety Commission (Part 8101)
LXXIII	Department of Agriculture (Part 8301)
LXXIV	Federal Mine Safety and Health Review Commission (Part 8401)
LXXVI	Federal Retirement Thrift Investment Board (Part 8601)
LXXVII	Office of Management and Budget (Part 8701)

## **Title 6—Homeland Security**

I	Department of Homeland Security, Office of the Secretary (Parts 0—99)
---	--

## **Title 7—Agriculture**

SUBTITLE A—OFFICE OF THE SECRETARY OF AGRICULTURE (PARTS  
0—26)

SUBTITLE B—REGULATIONS OF THE DEPARTMENT OF AGRICULTURE

## Title 7—Agriculture—Continued

Chap.	
I	Agricultural Marketing Service (Standards, Inspections, Marketing Practices), Department of Agriculture (Parts 27—209)
II	Food and Nutrition Service, Department of Agriculture (Parts 210—299)
III	Animal and Plant Health Inspection Service, Department of Agriculture (Parts 300—399)
IV	Federal Crop Insurance Corporation, Department of Agriculture (Parts 400—499)
V	Agricultural Research Service, Department of Agriculture (Parts 500—599)
VI	Natural Resources Conservation Service, Department of Agriculture (Parts 600—699)
VII	Farm Service Agency, Department of Agriculture (Parts 700—799)
VIII	Grain Inspection, Packers and Stockyards Administration (Federal Grain Inspection Service), Department of Agriculture (Parts 800—899)
IX	Agricultural Marketing Service (Marketing Agreements and Orders; Fruits, Vegetables, Nuts), Department of Agriculture (Parts 900—999)
X	Agricultural Marketing Service (Marketing Agreements and Orders; Milk), Department of Agriculture (Parts 1000—1199)
XI	Agricultural Marketing Service (Marketing Agreements and Orders; Miscellaneous Commodities), Department of Agriculture (Parts 1200—1299)
XIV	Commodity Credit Corporation, Department of Agriculture (Parts 1400—1499)
XV	Foreign Agricultural Service, Department of Agriculture (Parts 1500—1599)
XVI	Rural Telephone Bank, Department of Agriculture (Parts 1600—1699)
XVII	Rural Utilities Service, Department of Agriculture (Parts 1700—1799)
XVIII	Rural Housing Service, Rural Business-Cooperative Service, Rural Utilities Service, and Farm Service Agency, Department of Agriculture (Parts 1800—2099)
XX	Local Television Loan Guarantee Board (Parts 2200—2299)
XXXVI	Office of Inspector General, Department of Agriculture (Parts 2600—2699)
XXVII	Office of Information Resources Management, Department of Agriculture (Parts 2700—2799)
XXVIII	Office of Operations, Department of Agriculture (Parts 2800—2899)
XXIX	Office of Energy, Department of Agriculture (Parts 2900—2999)
XXX	Office of the Chief Financial Officer, Department of Agriculture (Parts 3000—3099)
XXXI	Office of Environmental Quality, Department of Agriculture (Parts 3100—3199)
XXXII	Office of Procurement and Property Management, Department of Agriculture (Parts 3200—3299)

## **Title 7—Agriculture—Continued**

Chap.	
XXXIII	Office of Transportation, Department of Agriculture (Parts 3300—3399)
XXXIV	Cooperative State Research, Education, and Extension Service, Department of Agriculture (Parts 3400—3499)
XXXV	Rural Housing Service, Department of Agriculture (Parts 3500—3599)
XXXVI	National Agricultural Statistics Service, Department of Agriculture (Parts 3600—3699)
XXXVII	Economic Research Service, Department of Agriculture (Parts 3700—3799)
XXXVIII	World Agricultural Outlook Board, Department of Agriculture (Parts 3800—3899)
XLI	[Reserved]
XLII	Rural Business-Cooperative Service and Rural Utilities Service, Department of Agriculture (Parts 4200—4299)

## **Title 8—Aliens and Nationality**

I	Department of Homeland Security (Immigration and Naturalization) (Parts 1—599)
V	Executive Office for Immigration Review, Department of Justice (Parts 1000—1400)

## **Title 9—Animals and Animal Products**

I	Animal and Plant Health Inspection Service, Department of Agriculture (Parts 1—199)
II	Grain Inspection, Packers and Stockyards Administration (Packers and Stockyards Programs), Department of Agriculture (Parts 200—299)
III	Food Safety and Inspection Service, Department of Agriculture (Parts 300—599)

## **Title 10—Energy**

I	Nuclear Regulatory Commission (Parts 0—199)
II	Department of Energy (Parts 200—699)
III	Department of Energy (Parts 700—999)
X	Department of Energy (General Provisions) (Parts 1000—1099)
XVII	Defense Nuclear Facilities Safety Board (Parts 1700—1799)
XVIII	Northeast Interstate Low-Level Radioactive Waste Commission (Part 1800)

## **Title 11—Federal Elections**

I	Federal Election Commission (Parts 1—9099)
---	--



## **Title 12—Banks and Banking**

- Chap.
- I Comptroller of the Currency, Department of the Treasury (Parts 1—199)
  - II Federal Reserve System (Parts 200—299)
  - III Federal Deposit Insurance Corporation (Parts 300—399)
  - IV Export-Import Bank of the United States (Parts 400—499)
  - V Office of Thrift Supervision, Department of the Treasury (Parts 500—599)
  - VI Farm Credit Administration (Parts 600—699)
  - VII National Credit Union Administration (Parts 700—799)
  - VIII Federal Financing Bank (Parts 800—899)
  - IX Federal Housing Finance Board (Parts 900—999)
  - XI Federal Financial Institutions Examination Council (Parts 1100—1199)
  - XIV Farm Credit System Insurance Corporation (Parts 1400—1499)
  - XV Department of the Treasury (Parts 1500—1599)
  - XVII Office of Federal Housing Enterprise Oversight, Department of Housing and Urban Development (Parts 1700—1799)
  - XVIII Community Development Financial Institutions Fund, Department of the Treasury (Parts 1800—1899)

## **Title 13—Business Credit and Assistance**

- I Small Business Administration (Parts 1—199)
- III Economic Development Administration, Department of Commerce (Parts 300—399)
- IV Emergency Steel Guarantee Loan Board (Parts 400—499)
- V Emergency Oil and Gas Guaranteed Loan Board (Parts 500—599)

## **Title 14—Aeronautics and Space**

- I Federal Aviation Administration, Department of Transportation (Parts 1—199)
- II Office of the Secretary, Department of Transportation (Aviation Proceedings) (Parts 200—399)
- III Commercial Space Transportation, Federal Aviation Administration, Department of Transportation (Parts 400—499)
- V National Aeronautics and Space Administration (Parts 1200—1299)
- VI Air Transportation System Stabilization (Parts 1300—1399)

## **Title 15—Commerce and Foreign Trade**

SUBTITLE A—OFFICE OF THE SECRETARY OF COMMERCE (PARTS 0—29)

SUBTITLE B—REGULATIONS RELATING TO COMMERCE AND FOREIGN TRADE

- I Bureau of the Census, Department of Commerce (Parts 30—199)

## **Title 15—Commerce and Foreign Trade—Continued**

Chap.

- II National Institute of Standards and Technology, Department of Commerce (Parts 200—299)
- III International Trade Administration, Department of Commerce (Parts 300—399)
- IV Foreign-Trade Zones Board, Department of Commerce (Parts 400—499)
- VII Bureau of Industry and Security, Department of Commerce (Parts 700—799)
- VIII Bureau of Economic Analysis, Department of Commerce (Parts 800—899)
- IX National Oceanic and Atmospheric Administration, Department of Commerce (Parts 900—999)
- XI Technology Administration, Department of Commerce (Parts 1100—1199)
- XIII East-West Foreign Trade Board (Parts 1300—1399)
- XIV Minority Business Development Agency (Parts 1400—1499)  
SUBTITLE C—REGULATIONS RELATING TO FOREIGN TRADE AGREEMENTS
- XX Office of the United States Trade Representative (Parts 2000—2099)  
SUBTITLE D—REGULATIONS RELATING TO TELECOMMUNICATIONS AND INFORMATION
- XXIII National Telecommunications and Information Administration, Department of Commerce (Parts 2300—2399)

## **Title 16—Commercial Practices**

- I Federal Trade Commission (Parts 0—999)
- II Consumer Product Safety Commission (Parts 1000—1799)

## **Title 17—Commodity and Securities Exchanges**

- I Commodity Futures Trading Commission (Parts 1—199)
- II Securities and Exchange Commission (Parts 200—399)
- IV Department of the Treasury (Parts 400—499)

## **Title 18—Conservation of Power and Water Resources**

- I Federal Energy Regulatory Commission, Department of Energy (Parts 1—399)
- III Delaware River Basin Commission (Parts 400—499)
- VI Water Resources Council (Parts 700—799)
- VIII Susquehanna River Basin Commission (Parts 800—899)
- XIII Tennessee Valley Authority (Parts 1300—1399)

## **Title 19—Customs Duties**

- I United States Customs Service, Department of the Treasury (Parts 1—199)

- Title 19—Customs Duties—Continued**
- Chap.
- II United States International Trade Commission (Parts 200—299)
  - III International Trade Administration, Department of Commerce (Parts 300—399)

**Title 20—Employees' Benefits**

- I Office of Workers' Compensation Programs, Department of Labor (Parts 1—199)
- II Railroad Retirement Board (Parts 200—399)
- III Social Security Administration (Parts 400—499)
- IV Employees' Compensation Appeals Board, Department of Labor (Parts 500—599)
- V Employment and Training Administration, Department of Labor (Parts 600—699)
- VI Employment Standards Administration, Department of Labor (Parts 700—799)
- VII Benefits Review Board, Department of Labor (Parts 800—899)
- VIII Joint Board for the Enrollment of Actuaries (Parts 900—999)
- IX Office of the Assistant Secretary for Veterans' Employment and Training, Department of Labor (Parts 1000—1099)

**Title 21—Food and Drugs**

- I Food and Drug Administration, Department of Health and Human Services (Parts 1—1299)
- II Drug Enforcement Administration, Department of Justice (Parts 1300—1399)
- III Office of National Drug Control Policy (Parts 1400—1499)

**Title 22—Foreign Relations**

- I Department of State (Parts 1—199)
- II Agency for International Development (Parts 200—299)
- III Peace Corps (Parts 300—399)
- IV International Joint Commission, United States and Canada (Parts 400—499)
- V Broadcasting Board of Governors (Parts 500—599)
- VII Overseas Private Investment Corporation (Parts 700—799)
- IX Foreign Service Grievance Board (Parts 900—999)
- X Inter-American Foundation (Parts 1000—1099)
- XI International Boundary and Water Commission, United States and Mexico, United States Section (Parts 1100—1199)
- XII United States International Development Cooperation Agency (Parts 1200—1299)
- XIV Foreign Service Labor Relations Board; Federal Labor Relations Authority; General Counsel of the Federal Labor Relations Authority; and the Foreign Service Impasse Disputes Panel (Parts 1400—1499)

## **Title 22—Foreign Relations—Continued**

Chap.

- XV African Development Foundation (Parts 1500—1599)
- XVI Japan-United States Friendship Commission (Parts 1600—1699)
- XVII United States Institute of Peace (Parts 1700—1799)

## **Title 23—Highways**

- I Federal Highway Administration, Department of Transportation (Parts 1—999)
- II National Highway Traffic Safety Administration and Federal Highway Administration, Department of Transportation (Parts 1200—1299)
- III National Highway Traffic Safety Administration, Department of Transportation (Parts 1300—1399)

## **Title 24—Housing and Urban Development**

SUBTITLE A—OFFICE OF THE SECRETARY, DEPARTMENT OF HOUSING AND URBAN DEVELOPMENT (PARTS 0—99)

SUBTITLE B—REGULATIONS RELATING TO HOUSING AND URBAN DEVELOPMENT

- I Office of Assistant Secretary for Equal Opportunity, Department of Housing and Urban Development (Parts 100—199)
- II Office of Assistant Secretary for Housing-Federal Housing Commissioner, Department of Housing and Urban Development (Parts 200—299)
- III Government National Mortgage Association, Department of Housing and Urban Development (Parts 300—399)
- IV Office of Housing and Office of Multifamily Housing Assistance Restructuring, Department of Housing and Urban Development (Parts 400—499)
- V Office of Assistant Secretary for Community Planning and Development, Department of Housing and Urban Development (Parts 500—599)
- VI Office of Assistant Secretary for Community Planning and Development, Department of Housing and Urban Development (Parts 600—699) [Reserved]
- VII Office of the Secretary, Department of Housing and Urban Development (Housing Assistance Programs and Public and Indian Housing Programs) (Parts 700—799)
- VIII Office of the Assistant Secretary for Housing—Federal Housing Commissioner, Department of Housing and Urban Development (Section 8 Housing Assistance Programs, Section 202 Direct Loan Program, Section 202 Supportive Housing for the Elderly Program and Section 811 Supportive Housing for Persons With Disabilities Program) (Parts 800—899)
- IX Office of Assistant Secretary for Public and Indian Housing, Department of Housing and Urban Development (Parts 900—1699)
- X Office of Assistant Secretary for Housing—Federal Housing Commissioner, Department of Housing and Urban Development (Interstate Land Sales Registration Program) (Parts 1700—1799)

## **Title 24—Housing and Urban Development—Continued**

Chap.

- XII Office of Inspector General, Department of Housing and Urban Development (Parts 2000—2099)
- XX Office of Assistant Secretary for Housing—Federal Housing Commissioner, Department of Housing and Urban Development (Parts 3200—3899)
- XXV Neighborhood Reinvestment Corporation (Parts 4100—4199)

## **Title 25—Indians**

- I Bureau of Indian Affairs, Department of the Interior (Parts 1—299)
- II Indian Arts and Crafts Board, Department of the Interior (Parts 300—399)
- III National Indian Gaming Commission, Department of the Interior (Parts 500—599)
- IV Office of Navajo and Hopi Indian Relocation (Parts 700—799)
- V Bureau of Indian Affairs, Department of the Interior, and Indian Health Service, Department of Health and Human Services (Part 900)
- VI Office of the Assistant Secretary-Indian Affairs, Department of the Interior (Parts 1000—1199)
- VII Office of the Special Trustee for American Indians, Department of the Interior (Part 1200)

## **Title 26—Internal Revenue**

- I Internal Revenue Service, Department of the Treasury (Parts 1—899)

## **Title 27—Alcohol, Tobacco Products and Firearms**

- I Alcohol and Tobacco Tax and Trade Bureau, Department of the Treasury (Parts 1—299)
- II Bureau of Alcohol, Tobacco, Firearms, and Explosives, Department of Justice (Parts 400—699)

## **Title 28—Judicial Administration**

- I Department of Justice (Parts 0—299)
- III Federal Prison Industries, Inc., Department of Justice (Parts 300—399)
- V Bureau of Prisons, Department of Justice (Parts 500—599)
- VI Offices of Independent Counsel, Department of Justice (Parts 600—699)
- VII Office of Independent Counsel (Parts 700—799)
- VIII Court Services and Offender Supervision Agency for the District of Columbia (Parts 800—899)
- IX National Crime Prevention and Privacy Compact Council (Parts 900—999)

## **Title 28—Judicial Administration—Continued**

Chap.

- XI Department of Justice and Department of State (Parts 1100—1199)

## **Title 29—Labor**

SUBTITLE A—OFFICE OF THE SECRETARY OF LABOR (PARTS 0—99)

SUBTITLE B—REGULATIONS RELATING TO LABOR

- I National Labor Relations Board (Parts 100—199)
- II Office of Labor-Management Standards, Department of Labor (Parts 200—299)
- III National Railroad Adjustment Board (Parts 300—399)
- IV Office of Labor-Management Standards, Department of Labor (Parts 400—499)
- V Wage and Hour Division, Department of Labor (Parts 500—899)
- IX Construction Industry Collective Bargaining Commission (Parts 900—999)
- X National Mediation Board (Parts 1200—1299)
- XII Federal Mediation and Conciliation Service (Parts 1400—1499)
- XIV Equal Employment Opportunity Commission (Parts 1600—1699)
- XVII Occupational Safety and Health Administration, Department of Labor (Parts 1900—1999)
- XX Occupational Safety and Health Review Commission (Parts 2200—2499)
- XXV Employee Benefits Security Administration, Department of Labor (Parts 2500—2599)
- XXVII Federal Mine Safety and Health Review Commission (Parts 2700—2799)
- XL Pension Benefit Guaranty Corporation (Parts 4000—4999)

## **Title 30—Mineral Resources**

- I Mine Safety and Health Administration, Department of Labor (Parts 1—199)
- II Minerals Management Service, Department of the Interior (Parts 200—299)
- III Board of Surface Mining and Reclamation Appeals, Department of the Interior (Parts 300—399)
- IV Geological Survey, Department of the Interior (Parts 400—499)
- VII Office of Surface Mining Reclamation and Enforcement, Department of the Interior (Parts 700—999)

## **Title 31—Money and Finance: Treasury**

SUBTITLE A—OFFICE OF THE SECRETARY OF THE TREASURY (PARTS 0—50)

SUBTITLE B—REGULATIONS RELATING TO MONEY AND FINANCE

- I Monetary Offices, Department of the Treasury (Parts 51—199)
- II Fiscal Service, Department of the Treasury (Parts 200—399)

## **Title 31—Money and Finance: Treasury—Continued**

Chap.

- IV Secret Service, Department of the Treasury (Parts 400—499)
- V Office of Foreign Assets Control, Department of the Treasury (Parts 500—599)
- VI Bureau of Engraving and Printing, Department of the Treasury (Parts 600—699)
- VII Federal Law Enforcement Training Center, Department of the Treasury (Parts 700—799)
- VIII Office of International Investment, Department of the Treasury (Parts 800—899)
- IX Federal Claims Collection Standards (Department of the Treasury—Department of Justice) (Parts 900—999)

## **Title 32—National Defense**

### SUBTITLE A—DEPARTMENT OF DEFENSE

- I Office of the Secretary of Defense (Parts 1—399)
  - V Department of the Army (Parts 400—699)
  - VI Department of the Navy (Parts 700—799)
  - VII Department of the Air Force (Parts 800—1099)
- ### SUBTITLE B—OTHER REGULATIONS RELATING TO NATIONAL DEFENSE
- XII Defense Logistics Agency (Parts 1200—1299)
  - XVI Selective Service System (Parts 1600—1699)
  - XXVIII National Counterintelligence Center (Parts 1800—1899)
  - XIX Central Intelligence Agency (Parts 1900—1999)
  - XX Information Security Oversight Office, National Archives and Records Administration (Parts 2000—2099)
  - XXI National Security Council (Parts 2100—2199)
  - XXIV Office of Science and Technology Policy (Parts 2400—2499)
  - XXVII Office for Micronesian Status Negotiations (Parts 2700—2799)
  - XXVIII Office of the Vice President of the United States (Parts 2800—2899)

## **Title 33—Navigation and Navigable Waters**

- I Coast Guard, Department of Transportation (Parts 1—199)
- II Corps of Engineers, Department of the Army (Parts 200—399)
- IV Saint Lawrence Seaway Development Corporation, Department of Transportation (Parts 400—499)

## **Title 34—Education**

### SUBTITLE A—OFFICE OF THE SECRETARY, DEPARTMENT OF EDUCATION (PARTS 1—99)

### SUBTITLE B—REGULATIONS OF THE OFFICES OF THE DEPARTMENT OF EDUCATION

- I Office for Civil Rights, Department of Education (Parts 100—199)

### **Title 34—Education—Continued**

Chap.

- II Office of Elementary and Secondary Education, Department of Education (Parts 200—299)
- III Office of Special Education and Rehabilitative Services, Department of Education (Parts 300—399)
- IV Office of Vocational and Adult Education, Department of Education (Parts 400—499)
- V Office of Bilingual Education and Minority Languages Affairs, Department of Education (Parts 500—599)
- VI Office of Postsecondary Education, Department of Education (Parts 600—699)
- XI National Institute for Literacy (Parts 1100—1199)  
SUBTITLE C—REGULATIONS RELATING TO EDUCATION
- XII National Council on Disability (Parts 1200—1299)

### **Title 35—Panama Canal**

- I Panama Canal Regulations (Parts 1—299)

### **Title 36—Parks, Forests, and Public Property**

- I National Park Service, Department of the Interior (Parts 1—199)
- II Forest Service, Department of Agriculture (Parts 200—299)
- III Corps of Engineers, Department of the Army (Parts 300—399)
- IV American Battle Monuments Commission (Parts 400—499)
- V Smithsonian Institution (Parts 500—599)
- VII Library of Congress (Parts 700—799)
- VIII Advisory Council on Historic Preservation (Parts 800—899)
- IX Pennsylvania Avenue Development Corporation (Parts 900—999)
- X Presidio Trust (Parts 1000—1099)
- XI Architectural and Transportation Barriers Compliance Board (Parts 1100—1199)
- XII National Archives and Records Administration (Parts 1200—1299)
- XV Oklahoma City National Memorial Trust (Part 1501)
- XVI Morris K. Udall Scholarship and Excellence in National Environmental Policy Foundation (Parts 1600—1699)

### **Title 37—Patents, Trademarks, and Copyrights**

- I United States Patent and Trademark Office, Department of Commerce (Parts 1—199)
- II Copyright Office, Library of Congress (Parts 200—299)
- IV Assistant Secretary for Technology Policy, Department of Commerce (Parts 400—499)
- V Under Secretary for Technology, Department of Commerce (Parts 500—599)



## **Title 38—Pensions, Bonuses, and Veterans' Relief**

Chap.

- I Department of Veterans Affairs (Parts 0—99)

## **Title 39—Postal Service**

- I United States Postal Service (Parts 1—999)
- III Postal Rate Commission (Parts 3000—3099)

## **Title 40—Protection of Environment**

- I Environmental Protection Agency (Parts 1—799)
- IV Environmental Protection Agency and Department of Justice (Parts 1400—1499)
- V Council on Environmental Quality (Parts 1500—1599)
- VI Chemical Safety and Hazard Investigation Board (Parts 1600—1699)
- VII Environmental Protection Agency and Department of Defense; Uniform National Discharge Standards for Vessels of the Armed Forces (Parts 1700—1799)

## **Title 41—Public Contracts and Property Management**

### SUBTITLE B—OTHER PROVISIONS RELATING TO PUBLIC CONTRACTS

- 50 Public Contracts, Department of Labor (Parts 50-1—50-999)
- 51 Committee for Purchase From People Who Are Blind or Severely Disabled (Parts 51-1—51-99)
- 60 Office of Federal Contract Compliance Programs, Equal Employment Opportunity, Department of Labor (Parts 60-1—60-999)
- 61 Office of the Assistant Secretary for Veterans' Employment and Training Service, Department of Labor (Parts 61-1—61-999)

### SUBTITLE C—FEDERAL PROPERTY MANAGEMENT REGULATIONS SYSTEM

- 101 Federal Property Management Regulations (Parts 101-1—101-99)
- 102 Federal Management Regulation (Parts 102-1—102-299)
- 105 General Services Administration (Parts 105-1—105-999)
- 109 Department of Energy Property Management Regulations (Parts 109-1—109-99)
- 114 Department of the Interior (Parts 114-1—114-99)
- 115 Environmental Protection Agency (Parts 115-1—115-99)
- 128 Department of Justice (Parts 128-1—128-99)

### SUBTITLE D—OTHER PROVISIONS RELATING TO PROPERTY MANAGEMENT [RESERVED]

### SUBTITLE E—FEDERAL INFORMATION RESOURCES MANAGEMENT REGULATIONS SYSTEM

- 201 Federal Information Resources Management Regulation (Parts 201-1—201-99) [Reserved]

### SUBTITLE F—FEDERAL TRAVEL REGULATION SYSTEM

- 300 General (Parts 300-1—300-99)
- 301 Temporary Duty (TDY) Travel Allowances (Parts 301-1—301-99)

## **Title 41—Public Contracts and Property Management—Continued**

Chap.

- 302 Relocation Allowances (Parts 302-1—302-99)
- 303 Payment of Expenses Connected with the Death of Certain Employees (Part 303-70)
- 304 Payment of Travel Expenses from a Non-Federal Source (Parts 304-1—304-99)

## **Title 42—Public Health**

- I Public Health Service, Department of Health and Human Services (Parts 1—199)
- IV Centers for Medicare & Medicaid Services, Department of Health and Human Services (Parts 400—499)
- V Office of Inspector General-Health Care, Department of Health and Human Services (Parts 1000—1999)

## **Title 43—Public Lands: Interior**

SUBTITLE A—OFFICE OF THE SECRETARY OF THE INTERIOR (PARTS 1—199)

SUBTITLE B—REGULATIONS RELATING TO PUBLIC LANDS

- I Bureau of Reclamation, Department of the Interior (Parts 200—499)
- II Bureau of Land Management, Department of the Interior (Parts 1000—9999)
- III Utah Reclamation Mitigation and Conservation Commission (Parts 10000—10005)

## **Title 44—Emergency Management and Assistance**

- I Federal Emergency Management Agency, Department of Homeland Security (Parts 0—399)
- IV Department of Commerce and Department of Transportation (Parts 400—499)

## **Title 45—Public Welfare**

SUBTITLE A—DEPARTMENT OF HEALTH AND HUMAN SERVICES (PARTS 1—199)

SUBTITLE B—REGULATIONS RELATING TO PUBLIC WELFARE

- II Office of Family Assistance (Assistance Programs), Administration for Children and Families, Department of Health and Human Services (Parts 200—299)
- III Office of Child Support Enforcement (Child Support Enforcement Program), Administration for Children and Families, Department of Health and Human Services (Parts 300—399)
- IV Office of Refugee Resettlement, Administration for Children and Families Department of Health and Human Services (Parts 400—499)
- V Foreign Claims Settlement Commission of the United States, Department of Justice (Parts 500—599)

## **Title 45—Public Welfare—Continued**

Chap.	
VI	National Science Foundation (Parts 600—699)
VII	Commission on Civil Rights (Parts 700—799)
VIII	Office of Personnel Management (Parts 800—899)
X	Office of Community Services, Administration for Children and Families, Department of Health and Human Services (Parts 1000—1099)
XI	National Foundation on the Arts and the Humanities (Parts 1100—1199)
XII	Corporation for National and Community Service (Parts 1200—1299)
XIII	Office of Human Development Services, Department of Health and Human Services (Parts 1300—1399)
XVI	Legal Services Corporation (Parts 1600—1699)
XVII	National Commission on Libraries and Information Science (Parts 1700—1799)
XVIII	Harry S. Truman Scholarship Foundation (Parts 1800—1899)
XXI	Commission on Fine Arts (Parts 2100—2199)
XXIII	Arctic Research Commission (Part 2301)
XXIV	James Madison Memorial Fellowship Foundation (Parts 2400—2499)
XXV	Corporation for National and Community Service (Parts 2500—2599)

## **Title 46—Shipping**

I	Coast Guard, Department of Transportation (Parts 1—199)
II	Maritime Administration, Department of Transportation (Parts 200—399)
III	Coast Guard (Great Lakes Pilotage), Department of Transportation (Parts 400—499)
IV	Federal Maritime Commission (Parts 500—599)

## **Title 47—Telecommunication**

I	Federal Communications Commission (Parts 0—199)
II	Office of Science and Technology Policy and National Security Council (Parts 200—299)
III	National Telecommunications and Information Administration, Department of Commerce (Parts 300—399)

## **Title 48—Federal Acquisition Regulations System**

1	Federal Acquisition Regulation (Parts 1—99)
2	Department of Defense (Parts 200—299)
3	Department of Health and Human Services (Parts 300—399)
4	Department of Agriculture (Parts 400—499)
5	General Services Administration (Parts 500—599)
6	Department of State (Parts 600—699)

## **Title 48—Federal Acquisition Regulations System—Continued**

Chap.

- 7 United States Agency for International Development (Parts 700—799)
- 8 Department of Veterans Affairs (Parts 800—899)
- 9 Department of Energy (Parts 900—999)
- 10 Department of the Treasury (Parts 1000—1099)
- 12 Department of Transportation (Parts 1200—1299)
- 13 Department of Commerce (Parts 1300—1399)
- 14 Department of the Interior (Parts 1400—1499)
- 15 Environmental Protection Agency (Parts 1500—1599)
- 16 Office of Personnel Management Federal Employees Health Benefits Acquisition Regulation (Parts 1600—1699)
- 17 Office of Personnel Management (Parts 1700—1799)
- 18 National Aeronautics and Space Administration (Parts 1800—1899)
- 19 Broadcasting Board of Governors (Parts 1900—1999)
- 20 Nuclear Regulatory Commission (Parts 2000—2099)
- 21 Office of Personnel Management, Federal Employees Group Life Insurance Federal Acquisition Regulation (Parts 2100—2199)
- 23 Social Security Administration (Parts 2300—2399)
- 24 Department of Housing and Urban Development (Parts 2400—2499)
- 25 National Science Foundation (Parts 2500—2599)
- 28 Department of Justice (Parts 2800—2899)
- 29 Department of Labor (Parts 2900—2999)
- 34 Department of Education Acquisition Regulation (Parts 3400—3499)
- 35 Panama Canal Commission (Parts 3500—3599)
- 44 Federal Emergency Management Agency (Parts 4400—4499)
- 51 Department of the Army Acquisition Regulations (Parts 5100—5199)
- 52 Department of the Navy Acquisition Regulations (Parts 5200—5299)
- 53 Department of the Air Force Federal Acquisition Regulation Supplement (Parts 5300—5399)
- 54 Defense Logistics Agency, Department of Defense (Parts 5400—5499)
- 57 African Development Foundation (Parts 5700—5799)
- 61 General Services Administration Board of Contract Appeals (Parts 6100—6199)
- 63 Department of Transportation Board of Contract Appeals (Parts 6300—6399)
- 99 Cost Accounting Standards Board, Office of Federal Procurement Policy, Office of Management and Budget (Parts 9900—9999)

## **Title 49—Transportation**

Chap.

- SUBTITLE A—OFFICE OF THE SECRETARY OF TRANSPORTATION (PARTS 1—99)
- SUBTITLE B—OTHER REGULATIONS RELATING TO TRANSPORTATION
- I Research and Special Programs Administration, Department of Transportation (Parts 100—199)
- II Federal Railroad Administration, Department of Transportation (Parts 200—299)
- III Federal Motor Carrier Safety Administration, Department of Transportation (Parts 300—399)
- IV Coast Guard, Department of Transportation (Parts 400—499)
- V National Highway Traffic Safety Administration, Department of Transportation (Parts 500—599)
- VI Federal Transit Administration, Department of Transportation (Parts 600—699)
- VII National Railroad Passenger Corporation (AMTRAK) (Parts 700—799)
- VIII National Transportation Safety Board (Parts 800—999)
- X Surface Transportation Board, Department of Transportation (Parts 1000—1399)
- XI Bureau of Transportation Statistics, Department of Transportation (Parts 1400—1499)
- XII Transportation Security Administration, Department of Transportation (Parts 1500—1599)

## **Title 50—Wildlife and Fisheries**

- I United States Fish and Wildlife Service, Department of the Interior (Parts 1—199)
- II National Marine Fisheries Service, National Oceanic and Atmospheric Administration, Department of Commerce (Parts 200—299)
- III International Fishing and Related Activities (Parts 300—399)
- IV Joint Regulations (United States Fish and Wildlife Service, Department of the Interior and National Marine Fisheries Service, National Oceanic and Atmospheric Administration, Department of Commerce); Endangered Species Committee Regulations (Parts 400—499)
- V Marine Mammal Commission (Parts 500—599)
- VI Fishery Conservation and Management, National Oceanic and Atmospheric Administration, Department of Commerce (Parts 600—699)

## **CFR Index and Finding Aids**

Subject/Agency Index

List of Agency Prepared Indexes

Parallel Tables of Statutory Authorities and Rules

List of CFR Titles, Chapters, Subchapters, and Parts

Alphabetical List of Agencies Appearing in the CFR



## Alphabetical List of Agencies Appearing in the CFR

(Revised as of July 1, 2003)

Agency	CFR Title, Subtitle or Chapter
Administrative Committee of the Federal Register	1, I
Advanced Research Projects Agency	32, I
Advisory Council on Historic Preservation	36, VIII
African Development Foundation	22, XV
Federal Acquisition Regulation	48, 57
Agency for International Development, United States	22, II
Federal Acquisition Regulation	48, 7
Agricultural Marketing Service	7, I, IX, X, XI
Agricultural Research Service	7, V
Agriculture Department	5, LXXIII
Agricultural Marketing Service	7, I, IX, X, XI
Agricultural Research Service	7, V
Animal and Plant Health Inspection Service	7, III; 9, I
Chief Financial Officer, Office of	7, XXX
Commodity Credit Corporation	7, XIV
Cooperative State Research, Education, and Extension Service	7, XXXIV
Economic Research Service	7, XXXVII
Energy, Office of	7, XXIX
Environmental Quality, Office of	7, XXXI
Farm Service Agency	7, VII, XVIII
Federal Acquisition Regulation	48, 4
Federal Crop Insurance Corporation	7, IV
Food and Nutrition Service	7, II
Food Safety and Inspection Service	9, III
Foreign Agricultural Service	7, XV
Forest Service	36, II
Grain Inspection, Packers and Stockyards Administration	7, VIII; 9, II
Information Resources Management, Office of	7, XXVII
Inspector General, Office of	7, XXVI
National Agricultural Library	7, XLI
National Agricultural Statistics Service	7, XXXVI
Natural Resources Conservation Service	7, VI
Operations, Office of	7, XXVIII
Procurement and Property Management, Office of	7, XXXII
Rural Business-Cooperative Service	7, XVIII, XLII
Rural Development Administration	7, XLII
Rural Housing Service	7, XVIII, XXXV
Rural Telephone Bank	7, XVI
Rural Utilities Service	7, XVII, XVIII, XLII
Secretary of Agriculture, Office of	7, Subtitle A
Transportation, Office of	7, XXXIII
World Agricultural Outlook Board	7, XXXVIII
Air Force Department	32, VII
Federal Acquisition Regulation Supplement	48, 53
Air Transportation Stabilization Board	14, VI
Alcohol and Tobacco Tax and Trade Bureau	27, I
Alcohol, Tobacco, Firearms, and Explosives, Bureau of	27, II
AMTRAK	49, VII
American Battle Monuments Commission	36, IV
American Indians, Office of the Special Trustee	25, VII
Animal and Plant Health Inspection Service	7, III; 9, I
Appalachian Regional Commission	5, IX

Agency	CFR Title, Subtitle or Chapter
Architectural and Transportation Barriers Compliance Board	36, XI
Arctic Research Commission	45, XXIII
Armed Forces Retirement Home	5, XI
Army Department	32, V
Engineers, Corps of	33, II; 36, III
Federal Acquisition Regulation	48, 51
Benefits Review Board	20, VII
Bilingual Education and Minority Languages Affairs, Office of	34, V
Blind or Severely Disabled, Committee for Purchase From People Who Are	41, 51
Broadcasting Board of Governors	22, V
Federal Acquisition Regulation	48, 19
Census Bureau	15, I
Centers for Medicare & Medicaid Services	42, IV
Central Intelligence Agency	32, XIX
Chief Financial Officer, Office of	7, XXX
Child Support Enforcement, Office of	45, III
Children and Families, Administration for	45, II, III, IV, X
Civil Rights, Commission on	45, VII
Civil Rights, Office for	34, I
Coast Guard	33, I; 46, I; 49, IV
Coast Guard (Great Lakes Pilotage)	46, III
Commerce Department	44, IV
Census Bureau	15, I
Economic Affairs, Under Secretary	37, V
Economic Analysis, Bureau of	15, VIII
Economic Development Administration	13, III
Emergency Management and Assistance	44, IV
Federal Acquisition Regulation	48, 13
Fishery Conservation and Management	50, VI
Foreign-Trade Zones Board	15, IV
Industry and Security, Bureau of	15, VII
International Trade Administration	15, III; 19, III
National Institute of Standards and Technology	15, II
National Marine Fisheries Service	50, II, IV, VI
National Oceanic and Atmospheric Administration	15, IX; 50, II, III, IV, VI
National Telecommunications and Information Administration	15, XXIII; 47, III
National Weather Service	15, IX
Patent and Trademark Office, United States	37, I
Productivity, Technology and Innovation, Assistant Secretary for	37, IV
Secretary of Commerce, Office of	15, Subtitle A
Technology, Under Secretary for	37, V
Technology Administration	15, XI
Technology Policy, Assistant Secretary for	37, IV
Commercial Space Transportation	14, III
Commodity Credit Corporation	7, XIV
Commodity Futures Trading Commission	5, XLI; 17, I
Community Planning and Development, Office of Assistant Secretary for	24, V, VI
Community Services, Office of	45, X
Comptroller of the Currency	12, I
Construction Industry Collective Bargaining Commission	29, IX
Consumer Product Safety Commission	5, LXXI; 16, II
Cooperative State Research, Education, and Extension Service	7, XXXIV
Copyright Office	37, II
Corporation for National and Community Service	45, XII, XXV
Cost Accounting Standards Board	48, 99
Council on Environmental Quality	40, V
Court Services and Offender Supervision Agency for the District of Columbia	28, VIII
Customs Service, United States	19, I
Defense Contract Audit Agency	32, I
Defense Department	5, XXVI; 32, Subtitle A; 40, VII



Agency	CFR Title, Subtitle or Chapter
Advanced Research Projects Agency	32, I
Air Force Department	32, VII
Army Department	32, V; 33, II; 36, III, 48, 51
Defense Intelligence Agency	32, I
Defense Logistics Agency	32, I, XII; 48, 54
Engineers, Corps of	33, II; 36, III
Federal Acquisition Regulation	48, 2
National Imagery and Mapping Agency	32, I
Navy Department	32, VI; 48, 52
Secretary of Defense, Office of	32, I
Defense Contract Audit Agency	32, I
Defense Intelligence Agency	32, I
Defense Logistics Agency	32, XII; 48, 54
Defense Nuclear Facilities Safety Board	10, XVII
Delaware River Basin Commission	18, III
District of Columbia, Court Services and Offender Supervision Agency for the	28, VIII
Drug Enforcement Administration	21, II
East-West Foreign Trade Board	15, XIII
Economic Affairs, Under Secretary	37, V
Economic Analysis, Bureau of	15, VIII
Economic Development Administration	13, III
Economic Research Service	7, XXXVII
Education, Department of	5, LIII
Bilingual Education and Minority Languages Affairs, Office of	34, V
Civil Rights, Office for	34, I
Educational Research and Improvement, Office of	34, VII
Elementary and Secondary Education, Office of	34, II
Federal Acquisition Regulation	48, 34
Postsecondary Education, Office of	34, VI
Secretary of Education, Office of	34, Subtitle A
Special Education and Rehabilitative Services, Office of	34, III
Vocational and Adult Education, Office of	34, IV
Educational Research and Improvement, Office of	34, VII
Elementary and Secondary Education, Office of	34, II
Emergency Oil and Gas Guaranteed Loan Board	13, V
Emergency Steel Guarantee Loan Board	13, IV
Employee Benefits Security Administration	29, XXV
Employees' Compensation Appeals Board	20, IV
Employees Loyalty Board	5, V
Employment and Training Administration	20, V
Employment Standards Administration	20, VI
Endangered Species Committee	50, IV
Energy, Department of	5, XXIII; 10, II, III, X
Federal Acquisition Regulation	48, 9
Federal Energy Regulatory Commission	5, XXIV; 18, I
Property Management Regulations	41, 109
Energy, Office of	7, XXIX
Engineers, Corps of	33, II; 36, III
Engraving and Printing, Bureau of	31, VI
Environmental Protection Agency	5, LIV; 40, I, IV, VII
Federal Acquisition Regulation	48, 15
Property Management Regulations	41, 115
Environmental Quality, Office of	7, XXXI
Equal Employment Opportunity Commission	5, LXII; 29, XIV
Equal Opportunity, Office of Assistant Secretary for	24, I
Executive Office of the President	3, I
Administration, Office of	5, XV
Environmental Quality, Council on	40, V
Management and Budget, Office of	5, III, LXXVII; 14, VI; 48, 99
National Drug Control Policy, Office of	21, III
National Security Council	32, XXI; 47, 2
Presidential Documents	3
Science and Technology Policy, Office of	32, XXIV; 47, II

Agency	CFR Title, Subtitle or Chapter
Trade Representative, Office of the United States	15, XX
Export-Import Bank of the United States	5, LII; 12, IV
Family Assistance, Office of	45, II
Farm Credit Administration	5, XXXI; 12, VI
Farm Credit System Insurance Corporation	5, XXX; 12, XIV
Farm Service Agency	7, VII, XVIII
Federal Acquisition Regulation	48, I
Federal Aviation Administration	14, I
Commercial Space Transportation	14, III
Federal Claims Collection Standards	31, IX
Federal Communications Commission	5, XXIX; 47, I
Federal Contract Compliance Programs, Office of	41, 60
Federal Crop Insurance Corporation	7, IV
Federal Deposit Insurance Corporation	5, XXII; 12, III
Federal Election Commission	11, I
Federal Emergency Management Agency	44, I
Federal Acquisition Regulation	48, 44
Federal Employees Group Life Insurance Federal Acquisition Regulation	48, 21
Federal Employees Health Benefits Acquisition Regulation	48, 16
Federal Energy Regulatory Commission	5, XXIV; 18, I
Federal Financial Institutions Examination Council	12, XI
Federal Financing Bank	12, VIII
Federal Highway Administration	23, I, II
Federal Home Loan Mortgage Corporation	1, IV
Federal Housing Enterprise Oversight Office	12, XVII
Federal Housing Finance Board	12, IX
Federal Labor Relations Authority, and General Counsel of the Federal Labor Relations Authority	5, XIV; 22, XIV
Federal Law Enforcement Training Center	31, VII
Federal Management Regulation	41, 102
Federal Maritime Commission	46, IV
Federal Mediation and Conciliation Service	29, XII
Federal Mine Safety and Health Review Commission	5, LXXIV; 29, XXVII
Federal Motor Carrier Safety Administration	49, III
Federal Prison Industries, Inc.	28, III
Federal Procurement Policy Office	48, 99
Federal Property Management Regulations	41, 101
Federal Railroad Administration	49, II
Federal Register, Administrative Committee of	1, I
Federal Register, Office of	1, II
Federal Reserve System	12, II
Board of Governors	5, LVIII
Federal Retirement Thrift Investment Board	5, VI, LXXVI
Federal Service Impasses Panel	5, XIV
Federal Trade Commission	5, XLVII; 16, I
Federal Transit Administration	49, VI
Federal Travel Regulation System	41, Subtitle F
Fine Arts, Commission on	45, XXI
Fiscal Service	31, II
Fish and Wildlife Service, United States	50, I, IV
Fishery Conservation and Management	50, VI
Food and Drug Administration	21, I
Food and Nutrition Service	7, II
Food Safety and Inspection Service	9, III
Foreign Agricultural Service	7, XV
Foreign Assets Control, Office of	31, V
Foreign Claims Settlement Commission of the United States	45, V
Foreign Service Grievance Board	22, IX
Foreign Service Impasse Disputes Panel	22, XIV
Foreign Service Labor Relations Board	22, XIV
Foreign-Trade Zones Board	15, IV
Forest Service	36, II
General Accounting Office	4, I
General Services Administration	5, LVII; 41, 105
Contract Appeals, Board of	48, 61
Federal Acquisition Regulation	48, 5

Agency	CFR Title, Subtitle or Chapter
Federal Management Regulation	41, 102
Federal Property Management Regulations	41, 101
Federal Travel Regulation System	41, Subtitle F
General	41, 300
Payment From a Non-Federal Source for Travel Expenses	41, 304
Payment of Expenses Connected With the Death of Certain Employees	41, 303
Relocation Allowances	41, 302
Temporary Duty (TDY) Travel Allowances	41, 301
Geological Survey	30, IV
Government Ethics, Office of	5, XVI
Government National Mortgage Association	24, III
Grain Inspection, Packers and Stockyards Administration	7, VIII; 9, II
Harry S. Truman Scholarship Foundation	45, XVIII
Health and Human Services, Department of	5, XLV; 45, Subtitle A
Centers for Medicare & Medicaid Services	42, IV
Child Support Enforcement, Office of	45, III
Children and Families, Administration for	45, II, III, IV, X
Community Services, Office of	45, X
Family Assistance, Office of	45, II
Federal Acquisition Regulation	48, 3
Food and Drug Administration	21, I
Human Development Services, Office of	45, XIII
Indian Health Service	25, V; 42, I
Inspector General (Health Care), Office of	42, V
Public Health Service	42, I
Refugee Resettlement, Office of	45, IV
Homeland Security, Department of	6, I
Federal Emergency Management Agency	44, I
Immigration and Naturalization	8, I
Housing and Urban Development, Department of	5, LXV; 24, Subtitle B
Community Planning and Development, Office of Assistant Secretary for	24, V, VI
Equal Opportunity, Office of Assistant Secretary for	24, I
Federal Acquisition Regulation	48, 24
Federal Housing Enterprise Oversight, Office of	12, XVII
Government National Mortgage Association	24, III
Housing—Federal Housing Commissioner, Office of Assistant Secretary for	24, II, VIII, X, XX
Housing, Office of, and Multifamily Housing Assistance	24, IV
Restructuring, Office of	
Inspector General, Office of	24, XII
Public and Indian Housing, Office of Assistant Secretary for Secretary, Office of	24, IX 24, Subtitle A, VII
Housing—Federal Housing Commissioner, Office of Assistant Secretary for	24, II, VIII, X, XX
Housing, Office of, and Multifamily Housing Assistance	24, IV
Restructuring, Office of	
Human Development Services, Office of	45, XIII
Immigration and Naturalization	8, I
Immigration Review, Executive Office for	8, V
Independent Counsel, Office of	28, VII
Indian Affairs, Bureau of	25, I, V
Indian Affairs, Office of the Assistant Secretary	25, VI
Indian Arts and Crafts Board	25, II
Indian Health Service	25, V; 42, I
Industry and Security, Bureau of	15, VII
Information Resources Management, Office of	7, XXVII
Information Security Oversight Office, National Archives and Records Administration	32, XX
Inspector General	
Agriculture Department	7, XXVI
Health and Human Services Department	42, V
Housing and Urban Development Department	24, XII
Institute of Peace, United States	22, XXVII
Inter-American Foundation	5, LXIII; 22, X
Interior Department	

Agency	CFR Title, Subtitle or Chapter
American Indians, Office of the Special Trustee	25, VII
Endangered Species Committee	50, IV
Federal Acquisition Regulation	48, 14
Federal Property Management Regulations System	41, 114
Fish and Wildlife Service, United States	50, I, IV
Geological Survey	30, IV
Indian Affairs, Bureau of	25, I, V
Indian Affairs, Office of the Assistant Secretary	25, VI
Indian Arts and Crafts Board	25, II
Land Management, Bureau of	43, II
Minerals Management Service	30, II
National Indian Gaming Commission	25, III
National Park Service	36, I
Reclamation, Bureau of	43, I
Secretary of the Interior, Office of	43, Subtitle A
Surface Mining and Reclamation Appeals, Board of	30, III
Surface Mining Reclamation and Enforcement, Office of	30, VII
Internal Revenue Service	26, I
International Boundary and Water Commission, United States and Mexico, United States Section	22, XI
International Development, United States Agency for Federal Acquisition Regulation	22, II 48, 7
International Development Cooperation Agency, United States	22, XII
International Fishing and Related Activities	50, III
International Investment, Office of	31, VIII
International Joint Commission, United States and Canada	22, IV
International Organizations Employees Loyalty Board	5, V
International Trade Administration	15, III; 19, III
International Trade Commission, United States	19, II
Interstate Commerce Commission	5, XL
James Madison Memorial Fellowship Foundation	45, XXIV
Japan-United States Friendship Commission	22, XVI
Joint Board for the Enrollment of Actuaries	20, VIII
Justice Department	5, XXVIII; 28, I, XI; 40, IV
Alcohol, Tobacco, Firearms, and Explosives, Bureau of	27, II
Drug Enforcement Administration	21, II
Federal Acquisition Regulation	48, 28
Federal Claims Collection Standards	31, IX
Federal Prison Industries, Inc.	28, III
Foreign Claims Settlement Commission of the United States	45, V
Immigration Review, Executive Office for	8, V
Offices of Independent Counsel	28, VI
Prisons, Bureau of	28, V
Property Management Regulations	41, 128
Labor Department	5, XLII
Benefits Review Board	20, VII
Employee Benefits Security Administration	29, XXV
Employees' Compensation Appeals Board	20, IV
Employment and Training Administration	20, V
Employment Standards Administration	20, VI
Federal Acquisition Regulation	48, 29
Federal Contract Compliance Programs, Office of	41, 60
Federal Procurement Regulations System	41, 50
Labor-Management Standards, Office of	29, II, IV
Mine Safety and Health Administration	30, I
Occupational Safety and Health Administration	29, XVII
Public Contracts	41, 50
Secretary of Labor, Office of	29, Subtitle A
Veterans' Employment and Training Service, Office of the Assistant Secretary for	41, 61; 20, IX
Wage and Hour Division	29, V
Workers' Compensation Programs, Office of	20, I
Labor-Management Standards, Office of	29, II, IV
Land Management, Bureau of	43, II

Agency	CFR Title, Subtitle or Chapter
Legal Services Corporation	45, XVI
Library of Congress	36, VII
Copyright Office	37, II
Local Television Loan Guarantee Board	7, XX
Management and Budget, Office of	5, III, LXXVII; 14, VI; 48, 99
Marine Mammal Commission	50, V
Maritime Administration	46, II
Merit Systems Protection Board	5, II
Micronesian Status Negotiations, Office for	32, XXVII
Mine Safety and Health Administration	30, I
Minerals Management Service	30, II
Minority Business Development Agency	15, XIV
Miscellaneous Agencies	1, IV
Monetary Offices	31, I
Morris K. Udall Scholarship and Excellence in National Environmental Policy Foundation	36, XVI
National Aeronautics and Space Administration	5, LIX; 14, V
Federal Acquisition Regulation	48, 18
National Agricultural Library	7, XLI
National Agricultural Statistics Service	7, XXXVI
National and Community Service, Corporation for	45, XII, XXV
National Archives and Records Administration	5, LXVI; 36, XII
Information Security Oversight Office	32, XX
National Bureau of Standards	15, II
National Capital Planning Commission	1, IV
National Commission for Employment Policy	1, IV
National Commission on Libraries and Information Science	45, XVII
National Council on Disability	34, XII
National Counterintelligence Center	32, XVIII
National Credit Union Administration	12, VII
National Crime Prevention and Privacy Compact Council	28, IX
National Drug Control Policy, Office of	21, III
National Foundation on the Arts and the Humanities	45, XI
National Highway Traffic Safety Administration	23, II, III; 49, V
National Imagery and Mapping Agency	32, I
National Indian Gaming Commission	25, III
National Institute for Literacy	34, XI
National Institute of Standards and Technology	15, II
National Labor Relations Board	5, LXI; 29, I
National Marine Fisheries Service	50, II, IV, VI
National Mediation Board	29, X
National Oceanic and Atmospheric Administration	15, IX; 50, II, III, IV, VI
National Park Service	36, I
National Railroad Adjustment Board	29, III
National Railroad Passenger Corporation (AMTRAK)	49, VII
National Science Foundation	5, XLIII; 45, VI
Federal Acquisition Regulation	48, 25
National Security Council	32, XXI
National Security Council and Office of Science and Technology Policy	47, II
National Telecommunications and Information Administration	15, XXIII; 47, III
National Transportation Safety Board	49, VIII
National Weather Service	15, IX
Natural Resources Conservation Service	7, VI
Navajo and Hopi Indian Relocation, Office of	25, IV
Navy Department	32, VI
Federal Acquisition Regulation	48, 52
Neighborhood Reinvestment Corporation	24, XXV
Northeast Interstate Low-Level Radioactive Waste Commission	10, XVIII
Nuclear Regulatory Commission	5, XLVIII; 10, I
Federal Acquisition Regulation	48, 20
Occupational Safety and Health Administration	29, XVII
Occupational Safety and Health Review Commission	29, XX
Offices of Independent Counsel	28, VI

Agency	CFR Title, Subtitle or Chapter
Oklahoma City National Memorial Trust Operations Office	36, XV 7, XXXVIII
Overseas Private Investment Corporation	5, XXXIII; 22, VII
Panama Canal Commission	48, 35
Panama Canal Regulations	35, I
Patent and Trademark Office, United States	37, I
Payment From a Non-Federal Source for Travel Expenses	41, 304
Payment of Expenses Connected With the Death of Certain Employees	41, 303
Peace Corps	22, III
Pennsylvania Avenue Development Corporation	36, IX
Pension Benefit Guaranty Corporation	29, XL
Personnel Management, Office of	5, I, XXXV; 45, VIII
Federal Acquisition Regulation	48, 17
Federal Employees Group Life Insurance Federal Acquisition Regulation	48, 21
Federal Employees Health Benefits Acquisition Regulation	48, 16
Postal Rate Commission	5, XLVI; 39, III
Postal Service, United States	5, LX; 39, I
Postsecondary Education, Office of	34, VI
President's Commission on White House Fellowships	1, IV
Presidential Documents	3
Presidio Trust	36, X
Prisons, Bureau of	28, V
Procurement and Property Management, Office of	7, XXXII
Productivity, Technology and Innovation, Assistant Secretary	37, IV
Public Contracts, Department of Labor	41, 50
Public and Indian Housing, Office of Assistant Secretary for	24, IX
Public Health Service	42, I
Railroad Retirement Board	20, II
Reclamation, Bureau of	43, I
Refugee Resettlement, Office of	45, IV
Regional Action Planning Commissions	13, V
Relocation Allowances	41, 302
Research and Special Programs Administration	49, I
Rural Business-Cooperative Service	7, XVIII, XLII
Rural Development Administration	7, XLII
Rural Housing Service	7, XVIII, XXXV
Rural Telephone Bank	7, XVI
Rural Utilities Service	7, XVII, XVIII, XLII
Saint Lawrence Seaway Development Corporation	33, IV
Science and Technology Policy, Office of	32, XXIV
Science and Technology Policy, Office of, and National Security Council	47, II
Secret Service	31, IV
Securities and Exchange Commission	17, II
Selective Service System	32, XVI
Small Business Administration	13, I
Smithsonian Institution	36, V
Social Security Administration	20, III; 48, 23
Soldiers' and Airmen's Home, United States	5, XI
Special Counsel, Office of	5, VIII
Special Education and Rehabilitative Services, Office of	34, III
State Department	22, I; 28, XI
Federal Acquisition Regulation	48, 6
Surface Mining and Reclamation Appeals, Board of	30, III
Surface Mining Reclamation and Enforcement, Office of	30, VII
Surface Transportation Board	49, X
Susquehanna River Basin Commission	18, VIII
Technology Administration	15, XI
Technology Policy, Assistant Secretary for	37, IV
Technology, Under Secretary for	37, V
Tennessee Valley Authority	5, LXIX; 18, XIII
Thrift Supervision Office, Department of the Treasury	12, V
Trade Representative, United States, Office of	15, XX
Transportation, Department of	5, L

Agency	CFR Title, Subtitle or Chapter
Coast Guard	33, I; 46, I; 49, IV
Coast Guard (Great Lakes Pilotage)	46, III
Commercial Space Transportation	14, III
Contract Appeals, Board of	48, 63
Emergency Management and Assistance	44, IV
Federal Acquisition Regulation	48, 12
Federal Aviation Administration	14, I
Federal Highway Administration	23, I, II
Federal Motor Carrier Safety Administration	49, III
Federal Railroad Administration	49, II
Federal Transit Administration	49, VI
Maritime Administration	46, II
National Highway Traffic Safety Administration	23, II, III; 49, V
Research and Special Programs Administration	49, I
Saint Lawrence Seaway Development Corporation	33, IV
Secretary of Transportation, Office of	14, II; 49, Subtitle A
Surface Transportation Board	49, X
Transportation Security Administration	49, XII
Transportation Statistics Bureau	49, XI
Transportation, Office of	7, XXXIII
Transportation Security Administration	49, XII
Transportation Statistics Bureau	49, XI
Travel Allowances, Temporary Duty (TDY)	41, 301
Treasury Department	5, XXI; 12, XV; 17, IV;
	31, IX
Alcohol and Tobacco Tax and Trade Bureau	27, I
Community Development Financial Institutions Fund	12, XVIII
Comptroller of the Currency	12, I
Customs Service, United States	19, I
Engraving and Printing, Bureau of	31, VI
Federal Acquisition Regulation	48, 10
Federal Law Enforcement Training Center	31, VII
Fiscal Service	31, II
Foreign Assets Control, Office of	31, V
Internal Revenue Service	26, I
International Investment, Office of	31, VIII
Monetary Offices	31, I
Secret Service	31, IV
Secretary of the Treasury, Office of	31, Subtitle A
Thrift Supervision, Office of	12, V
Truman, Harry S. Scholarship Foundation	45, XVIII
United States and Canada, International Joint Commission	22, IV
United States and Mexico, International Boundary and Water Commission, United States Section	22, XI
Utah Reclamation Mitigation and Conservation Commission	43, III
Veterans Affairs Department	38, I
Federal Acquisition Regulation	48, 8
Veterans' Employment and Training Service, Office of the Assistant Secretary for	41, 61; 20, IX
Vice President of the United States, Office of	32, XXVIII
Vocational and Adult Education, Office of	34, IV
Wage and Hour Division	29, V
Water Resources Council	18, VI
Workers' Compensation Programs, Office of	20, I
World Agricultural Outlook Board	7, XXXVIII





## List of CFR Sections Affected

All changes in this volume of the Code of Federal Regulations which were made by documents published in the FEDERAL REGISTER since January 1, 2001, are enumerated in the following list. Entries indicate the nature of the changes effected. Page numbers refer to FEDERAL REGISTER pages. The user should consult the entries for chapters and parts as well as sections for revisions.

For the period before January 1, 2001, see the "List of CFR Sections Affected, 1949-1963, 1964-1972, 1973-1985, and 1986-2000" published in 11 separate volumes.

<b>36 CFR</b>	<b>2001</b>	<b>66 FR Page</b>	<b>36 CFR—Continued</b>	<b>67 FR Page</b>
Chapter XII			Chapter XI	
1202 Revised .....	65652		1191 Appendix A amended .....	56384
1220.14 Amended .....	27027		Chapter XII	
1220.52 (c) amended .....	27027		1200 Revised .....	72101
1228 Nomenclature change.....	27027		1201 Added; interim .....	44757
1228.28 (b)(8)(i) amended.....	27027		Regulation at 67 FR 44757 con-	
1228.44 Amended .....	27027		firmed.....	63267
1228.92 (e) amended .....	27027		1206 Revised .....	42494
1228.104 (b) amended .....	27027		1220.2 Amended.....	31962
1228.106 Amended.....	27027		1220.34 Amended.....	31962
1228.160 (f) revised.....	27027		1220.36 (c) amended .....	31962
1228.266 (e)(1) amended.....	27027		1222.20 (a) amended.....	31962
1228.270 (c)(2)(i) revised.....	27027		1228.12 Introductory text amend-	
1228.272 (b)(2) revised .....	27027		ed .....	43253
1228.282 Revised .....	27027		1228.22 Introductory text amend-	
1232.20 (a) and (e) amended .....	27027		ed .....	43253
1232.32 Amended .....	27027		1228.40 Revised .....	31962
1234 Nomenclature change.....	27028		1228.42 (a) and (b) revised; (c) re-	
1234.10 (a) amended .....	27028		designated as (d); new (c)	
1236.26 (a) and (c)(2) revised .....	27028		added.....	31962
1250 Revised .....	16376		(d) corrected .....	47701
1254.38 Removed .....	16382		1228.50 (a)(4) revised.....	31963
1254.39 Removed .....	16382		1228.150 (a) amended .....	43253
1254.44 Heading, (a) and (c) re-			1228.160 (f) amended .....	43253
vised.....	16382		1228.166 (b) amended.....	43253
1290.1 (b)(3) corrected.....	18873		1228.224 (a) revised .....	79518
1290.2 (f) corrected .....	18873		1228.270 (a), (b), and (c) revised; (f)	
Chapter XVI			added.....	79518
Chapter XVI Established.....	15034		1230 Revised .....	31693, 34575
			1230.2 Corrected.....	39473
			1250.12 (c) amended .....	43253
			1250.24 Amended .....	43253
			1250.76 Amended .....	43253
			1253.3 (a) thorough (j) revised .....	43254
			1253.5 Revised.....	43255
			1253.6 (a) through (f) and (h)	
			through (l) revised .....	43255

**36 CFR (7-1-03 Edition)**

**36 CFR—Continued**

Chapter XII—Continued	67 FR Page
1253.7 (b), (d), (g), (h) and (i) re- vised.....	43255
1253.8 Added .....	43255
1254.2 (a) revised .....	43254
1254.6 Revised .....	8200
(a) corrected .....	17286
(a) revised .....	63268
1254.25 Added .....	8200
1275 Authority citation re- vised.....	44766
1275.64 (d) revised.....	44766
1275.66 (a) revised.....	44766
1275 Appendix A amended .....	44766

**2003**

(Regulations published from January 1,  
2003, through July 1, 2003)

**36 CFR**

Chapter IV	68 FR Page
404 Revised .....	8826

**36 CFR—Continued**

Chapter IV—Continued	68 FR Page
405 Removed .....	8829
Chapter VII	
704.25 Added .....	11975
704.26 Added .....	11975
704.27 Added .....	11975
704.28 Added .....	11975
704.29 Added .....	11976
704.30 Added .....	11976
704.31 Added .....	11976
704.32 Added .....	11976
704.33 Added .....	11976
Chapter XI	
Chapter XII	
1253.3 (b), (e), (f), and (j) re- vised.....	33405
1253.4 Revised.....	33405
1253.6 (a) through (d) revised .....	33405
1253.7 (a) through (d) revised .....	33405

